

# REPORT DOCUMENTATION PAGE

Public reporting burden for this collection of information is estimated to average 1 hour per response, including the time for reviewing the data needed, and completing and reviewing this collection of information. Send comments regarding this burden estimate or reducing this burden to Washington Headquarters Services, Directorate for Information Operations and Reports, 1215 Jefferson Management and Budget, Paperwork Reduction Project (0704-0188), Washington, DC 20503

AFRL-SR-BL-TR-02-

ining  
for  
e of

0124

1. AGENCY USE ONLY (Leave blank)		2. REPORT DATE 7 March 2002	3. REPORT TYPE Final technical report, 5/97 - 5/01	
4. TITLE AND SUBTITLE <b>(AASERT) Research Training in Optical Propagation Through Turbulent Shear Flows</b>			5. FUNDING NUMBERS F49620-97-1-0417	
6. AUTHOR(S) C. Randall Truman				
7. PERFORMING ORGANIZATION NAME(S) AND ADDRESS(ES) University of New Mexico Department of Mechanical Engineering Albuquerque NM 87131			8. PERFORMING ORGANIZATION REPORT NUMBER N/A	
9. SPONSORING / MONITORING AGENCY NAME(S) AND ADDRESS(ES) Air Force Office of Scientific Research/NA 801 N. Randolph St., Rm 732 Arlington VA 22203-1977			10. SPONSORING / MONITORING AGENCY REPORT NUMBER	
11. SUPPLEMENTARY NOTES				
12a. DISTRIBUTION / AVAILABILITY STATEMENT <b>DISTRIBUTION STATEMENT A</b> Approved for Public Release Distribution Unlimited			12b. DISTRIBUTION CODE PUBLIC RELEASE	
13. ABSTRACT (Maximum 200 Words) An optical diagnostic system for turbulent shear flows was developed based on a Shack-Hartmann wavefront sensor. The sensor uses discrete lenslets to image small portions of the flow to determine the wavefront distortion caused by turbulent interfaces. The technique is particularly useful to identify turbulent coherent structure. The system was demonstrated for a plane mixing layer with small heat addition causing temperature to act as the passive scalar.				
14. SUBJECT TERMS			15. NUMBER OF PAGES 6	
			16. PRICE CODE	
17. SECURITY CLASSIFICATION OF REPORT	18. SECURITY CLASSIFICATION OF THIS PAGE	19. SECURITY CLASSIFICATION OF ABSTRACT	20. LIMITATION OF ABSTRACT	

AIR FORCE OFFICE OF SCIENTIFIC RESEARCH (AFOSR)  
NOTICE OF TRANSMITTAL DTIC. THIS TECHNICAL REPORT  
HAS BEEN REVIEWED AND IS APPROVED FOR PUBLIC RELEASE  
LAW AFM 100-12. DISTRIBUTION IS UNLIMITED.

20020402 081

## Research Training in Optical Propagation Through Turbulent Shear Flows (AASERT)

F49620-97-1-0417

Prof. C. Randall Truman

Graduate student: Patrocino Chavez

Department of Mechanical Engineering  
University of New Mexico  
Albuquerque NM 87131

Optical diagnostic techniques have become the mainstay of modern experimental fluid dynamics. These diagnostics allow non-intrusive measurement of velocity *fields*, as opposed to point measurements. Applications involving control of turbulent flows put particularly stringent requirements on the diagnostic system due to the presence of multiple scales in the flow and the often non-trivial interaction of the control actuators with the coherent structures. To facilitate the study of a wide variety of complex flows, two different diagnostic systems were developed at the Department of Mechanical Engineering at the University of New Mexico. A Hartmann sensor measures optical phase of a wavefront that has passed through a turbulent flow. A particle image velocimetry (PIV) system was also developed for the current work and a variety of other experiments – ranging from a study of a flow of viscous fluid from a crack in a pipe to an investigation of a series of tow-tank experiments intended to clarify certain fundamental aspects of bluff-body wakes.

**Hartmann Sensor:** The Shack-Hartmann wavefront sensor<sup>1,2</sup> is based on an array of lenslets, each of which focuses a very small section of an incoming laser beam onto a CCD array. The displacement of each focal spot in reference to the spot produced from a collimated beam is a measure of phase shift; this distribution can then be integrated to reconstruct the total wavefront. The distortion of the incident laser beam is related to turbulent structure in the flow. An optical system has been designed around a wind tunnel that incorporates such a sensor to study turbulent shear flows. A plane mixing layer is being studied to understand the type of wavefront signature to be expected from a turbulent free shear layer. This technique will be extended to the study of flow control using deformable surface airfoils.

The Wavefront Sciences optical diagnostic system was previously acquired with a AFOSR DURIP equipment grant. An optical system including laser diode source, focusing and imaging optics was developed to study the flow in a small wind tunnel obtained on loan from the Air Force Research Laboratory. This tunnel is equipped with optical quality windows transverse to the flow direction.

**PIV System:** Particle image velocimetry (PIV) uses two successive images of scattered laser light from small particles in the flow to determine velocity vectors in a plane. In practice a digital camera captures light from two laser pulses and sophisticated software

performs the correlations between particle positions needed to determine velocity. The particles are small enough to follow the motion without disturbing the flow.

A Kodak (now Roper Scientific) Megaplus ES 4.0 camera acquires 15 frames/second with 2048-pixel square resolution or 30 frames/second with a 1024-pixel square resolution. The camera sends a strobe signal to a Berkeley Nucleonics digital delay generator BNC-555, which in turn triggers the Nd:YAG Gemini PIV laser. For the experiments described in this report, the pulse frequency for each laser power supply was at 15 Hz, and the delay between the pulse trains was maintained at 1/30 s to provide continuous acquisition of 30 frames per second. However, the same schematic can be employed for PIV imaging of much faster flows with staggered-frame exposure of each frame pair or double-exposure of each frame.<sup>3</sup>

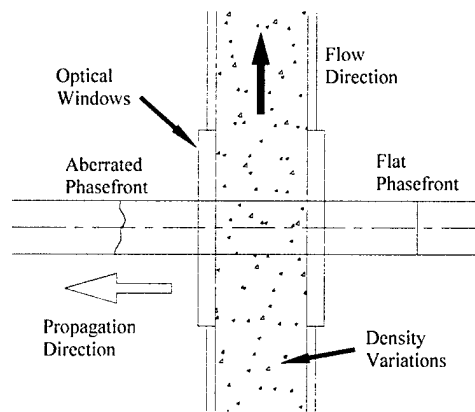

Figure 1 – Phasefront Aberration

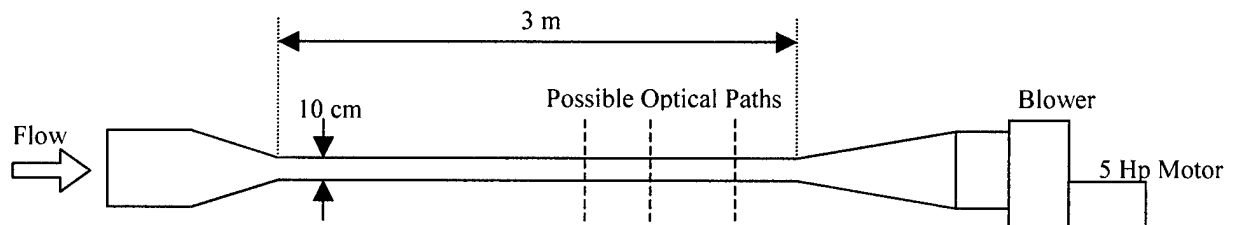

Figure 2a – Top View of tunnel

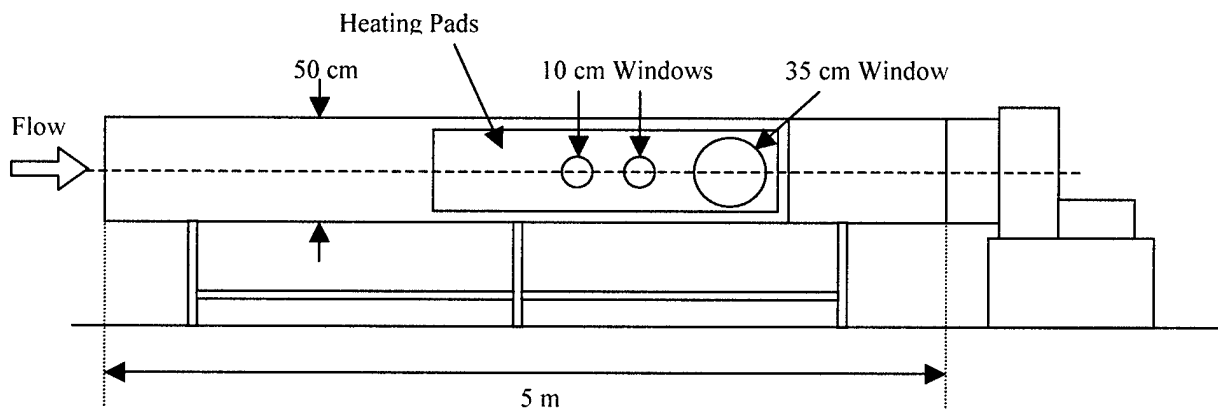

Figure 2b – Side View of tunnel

Figure 1 shows a schematic of propagation through a flow channel with windows. A plane mixing layer has been developed within the wind tunnel shown in Figure 2. Figure 3 is a schematic of the optical system required for the Hartmann sensor.

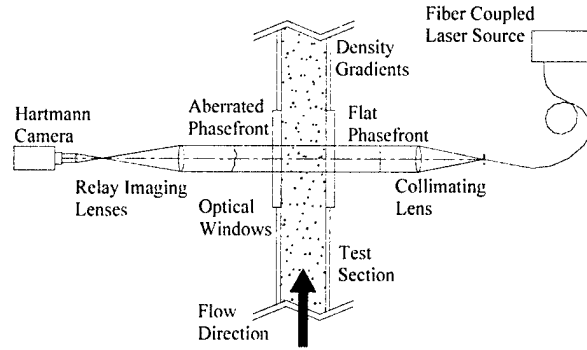

Figure 3. Schematic of optical system for Hartmann sensor

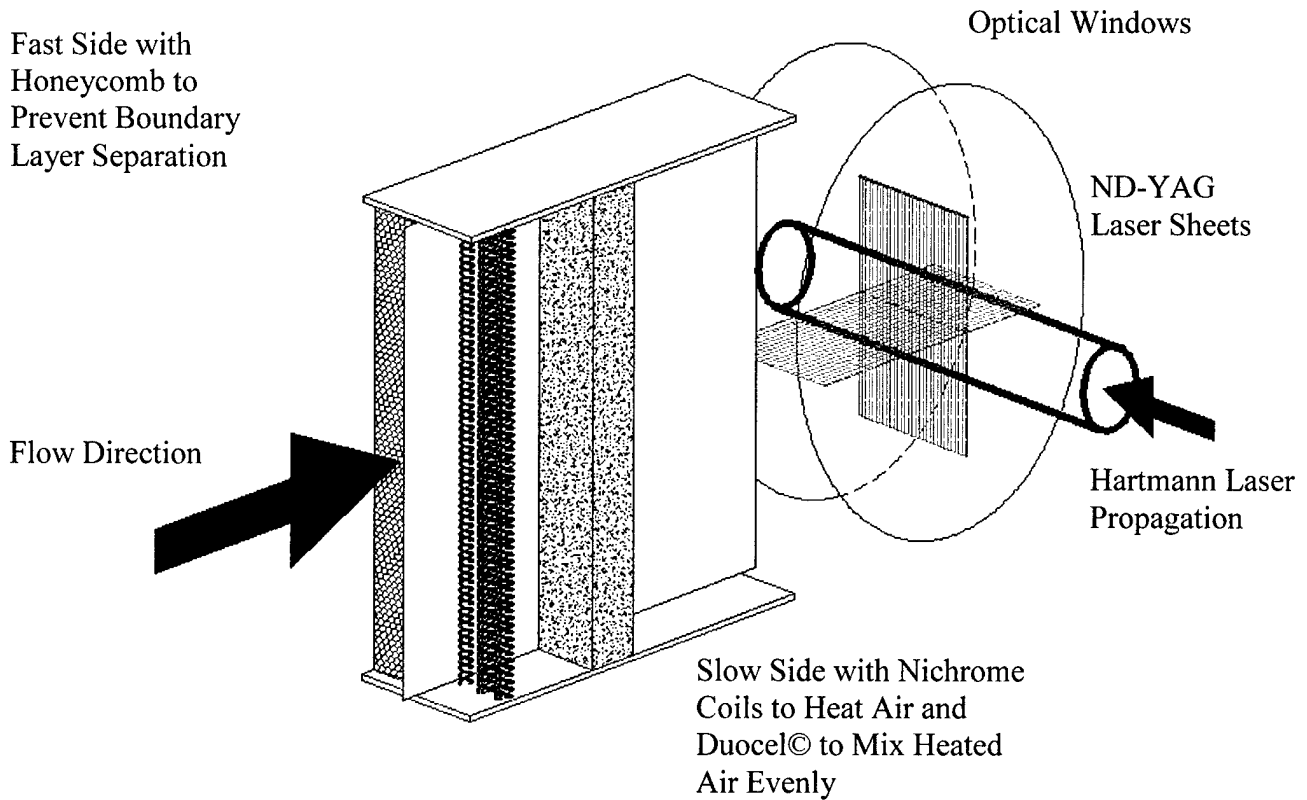

Figure 4. Splitter Plate Insert and Laser Sheet Flow Visualization

**Plane mixing layer.** A splitter plate is used to separate two airstreams within the tunnel and recombine them with different average velocities. The resulting plane mixing layer that exhibits the classic Kelvin-Helmholtz instability will be used to benchmark the wavefront sensor.<sup>4</sup> An aluminum composite sheet called Dibond<sup>®</sup> which possesses great rigidity was used for the splitter plate. Its machinability produced knife-edges at the leading and trailing edges to minimize boundary layer separation.

The Hartmann sensor requires that a small thermal tracer be added to the flow as a passive scalar. Heat must be added to a single side of the splitter plate as uniformly as possible so that structures within the mixing layer induce the dominant wavefront aberration. Nichrome coils heat the airstream on the slow side of the splitter plate upstream of the Duocel<sup>®</sup> aluminum foam (Figure 4); up to 1.5 kW of power can be dissipated from the coils. Duocel<sup>®</sup> pieces of varying stream-wise thickness can be used to produce seven possible velocity ratios ranging from  $\sim 1.5:1$  to  $\sim 5:1$ .

Flow visualization images of the mixing layer were acquired by illuminating tracer particles with a horizontal laser light sheet along the midline of the tunnel. For a velocity ratio of 3:1 and 50 mm downstream of the splitter plate, the Kelvin-Helmholtz instabilities induced by the shear layer develop into the classic laminar mixing layer structures (Figure 5). Larger velocity ratios, or positions further downstream will exhibit turbulent mixing layer structures much less recognizable but shear-driven nonetheless.



Figure 5 – Kelvin-Helmholtz Vortices in Mixing Layer

Figure 6 shows PIV results for the shear layer with the fluctuating velocity distribution on the left and the corresponding vorticity distribution on the right. The orientation of the view is approximately the same as the flow visualization shown in Figure 5, although the region of flow imaged is smaller. Both these images depict the flow in a horizontal plane that cuts through the roller vortices typical of the mixing layer.

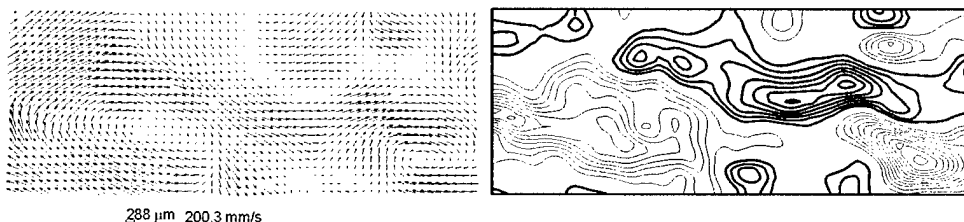

Fig. 6: Raw velocity fluctuation field (left) and corresponding vorticity maps (right) at the centerline of a shear layer in a wind tunnel. Freestream velocity is 1 m/s. Thick lines - positive (counterclockwise) vorticity, thin lines - negative (clockwise) vorticity.

Figure 7 is a compilation of data and flow visualization of the mixing layer created by the splitter plate insert. Anemometry data taken 160mm downstream of the splitter plate is shown in Figure 7a; hot-wire anemometry data in blue displays the velocity profile and cold-wire anemometry data in red displays the temperature profile. A 3:1 velocity ratio can be seen as well as an approximate 10°C increase in temperature on the slow side of the splitter plate. Figure 7b is a flow visualization image in the horizontal laser light sheet. Kelvin-Helmholtz instabilities are clearly evident and have “rolled up” into the classical mixing layer vortices. The image orientation corresponds to the profiles in figure 7a. Figure 7c shows Hartmann data images for the laser wavefront propagated through the wind tunnel at 160mm downstream, the location and relative length scale are indicated in figure 7b. The Hartmann images depict structure in both the vertical and streamwise directions; the vortices in the mixing layer should be uniform in the vertical direction, which means that other structures outside the mixing layer may be producing vertical gradients in the wavefront.

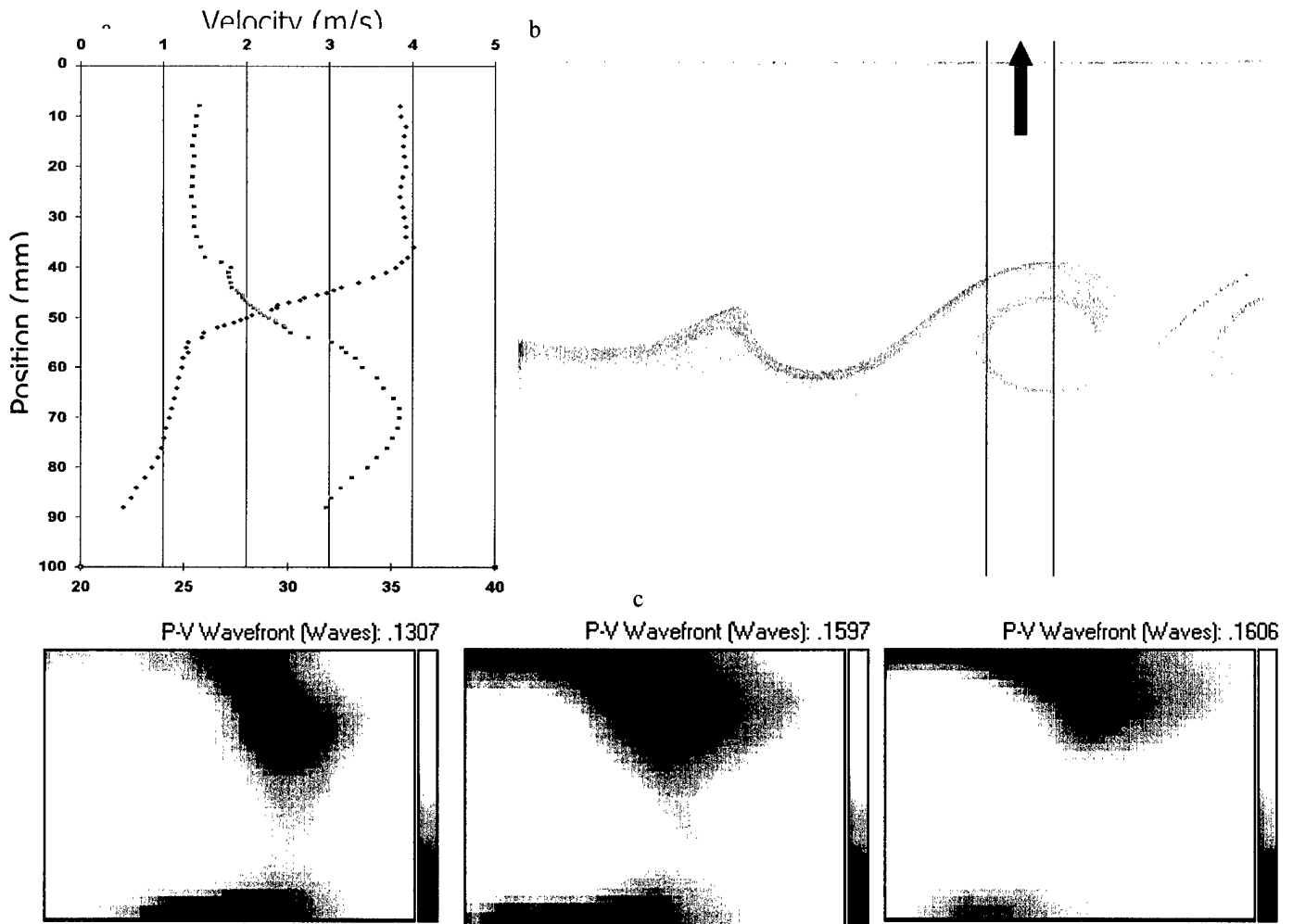

Figure 7 Mixing layer a) velocity and temperature profiles, b) flow visualization, c) Hartmann sensor images.

In summary, we have developed portable and versatile optical diagnostic systems that have been employed to perform wavefront and PIV measurements in several flow experiments, in particular a plane mixing layer. We are continuing to explore and expand their capabilities. Among the directions for future work is addition of the second laser/second camera to the setup to facilitate simultaneous PIV acquisition in two planes, as well as construction of more sophisticated actuators.

### References

1. Neal, D. R., Hedlund, E., Lederer, M., Collier, A., Springs, C., Yanta, W., "Shack-Hartmann Wavefront Sensor Testing of Aero-Optic Phenomena", AIAA Paper 98-2701, June 1998.
2. L. McMackin, R.J. Hugo, K.P. Bishop, E.Y. Chen, R.E. Pierson, and C.R. Truman, 1999, High speed optical tomography system for quantitative measurement and visualization of dynamic features in a round jet. *Experiments in Fluids*, 26:249-256.
3. P. Vorobieff, C.R. Truman, and J. Gallegos, PIV Diagnostics for Flow Control Applications, Proceedings of 2000 AFOSR Contractors' Meeting in Turbulence and Rotating Flows, AFOSR/NA, 285-289.
4. P. Chavez and C.R. Truman, Laser Wavefront Diagnostics of a Heated Mixing Layer, AIAA Paper 2002-2270