

Concepts and Techniques of Machine Safeguarding

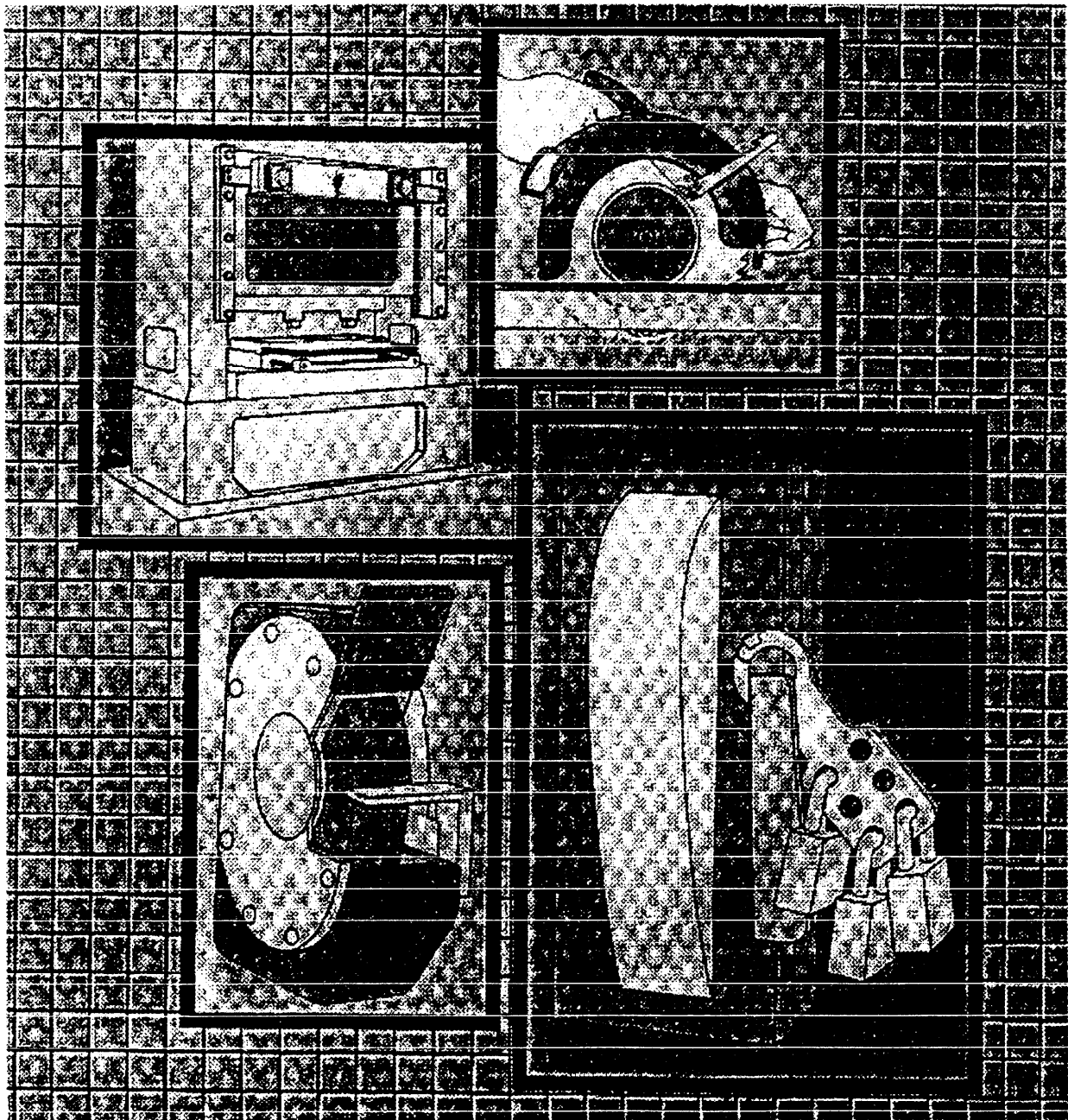

U.S. Department of Labor
Occupational Safety and Health Administration

OSHA 3067
1992 (Revised)



Report Documentation Page

Report Date 00001992	Report Type N/A	Dates Covered (from... to) -
Title and Subtitle Concepts and Techniques of Machine Safeguarding	Contract Number	
	Grant Number	
	Program Element Number	
Author(s)	Project Number	
	Task Number	
	Work Unit Number	
Performing Organization Name(s) and Address(es) U.S. Department of Labor Occupational Safety & Health Administration 200 Constitution Avenue Washington, DC 20210	Performing Organization Report Number OSHA 3067	
Sponsoring/Monitoring Agency Name(s) and Address(es)	Sponsor/Monitor's Acronym(s)	
	Sponsor/Monitor's Report Number(s)	
Distribution/Availability Statement Approved for public release, distribution unlimited		
Supplementary Notes		
Abstract This manual has been prepared as an aid to employers, employees, machine manufacturers, machine guard designers and fabricators, and all others with an interest in protecting workers against the hazards of moving machine parts. It identifies the major mechanical motions and the general principles of safeguarding them. Current applications of each technique area shown in accompanying illustrations of specific operations and machines. The methods described here may be transferred, with due care, to different machines with similar hazards. To determine whether or not safeguarding meets the requirements of the standard, any mechanical motion that threatens a worker's safety should not remain unguarded. The approaches to machine safeguarding discussed in this manual are not the only solutions which meet the requirements of the standard. Why? Because practical solutions to safeguarding moving machine parts are as numerous as the people working on them. No publication could keep pace with all of these solutions or attempt to depict them all.		
Subject Terms		
Report Classification unclassified	Classification of this page unclassified	

Classification of Abstract unclassified	Limitation of Abstract UU
Number of Pages 88	

Concepts and Techniques of Machine Safeguarding



U.S. Department of Labor
Lynn Martin, Secretary

Occupational Safety and Health Administration
Dorothy L. Strunk, Acting Assistant Secretary

OSHA 3067
1992 (Revised)

Table of Contents

Introduction	iv
Chapter	
1 Basics of Machine Safeguarding	1
2 Methods of Machine Safeguarding	11
3 Guard Construction.....	59
4 Machinery Maintenance and Repair	61
5 Utilization of Industry Consensus Standards	67
6 Robotics in the Workplace	71
7 Cellular Manufacturing Systems	73
8 Ergonomic Considerations of Machine Safeguarding.....	77
9 Cooperation and Assistance	79
Machine Guarding Checklist	80
Worker Rights and Responsibilities	82
Bibliography	84
States with Approved Plans	86
OSHA Consultation Project Directory	87
Related Publications	88

Introduction

This manual has been prepared as an aid to employers, employees, machine manufacturers, machine guard designers and fabricators, and all others with an interest in protecting workers against the hazards of moving machine parts. It identifies the major mechanical motions and the general principles of safeguarding them. Current applications of each technique are shown in accompanying illustrations of specific operations and machines. The methods described here may be transferred, with due care, to different machines with similar hazards. To determine whether or not safeguarding meets the requirements of the standard, any mechanical motion that threatens a worker's safety should not remain unguarded.

The approaches to machine safeguarding discussed in this manual are not the only solutions which meet the requirements of the standard. Why? Because practical solutions to safeguarding moving machine parts are as numerous as the people working on them. No publication could keep pace with all of these solutions or attempt to depict them all.

In machine safeguarding, as in other regulated areas of the American workplace, to a certain extent OSHA standards govern function and practice. This text, however, is not a substitute for the standards. It is a manual of basic technical information and workable ideas which the employer may use as a guide to achieving compliance. It offers an overview of the machine safeguarding problem in the industrial setting, an assortment of solutions in popular use, and a challenge to all whose work involves machines.

Many readers of this manual already have the judgment, knowledge, and skill to develop effective answers to problems yet unsolved. Innovators are encouraged to find here stimulation to eliminate mechanical hazards facing America's workers today.

Basics of Machine Safeguarding

Crushed hands and arms, severed fingers, blindness — the list of possible machinery-related injuries is as long as it is horrifying. There seem to be as many hazards created by moving machine parts as there are types of machines. Safeguards are essential for protecting workers from needless and preventable injuries.

A good rule to remember is: Any machine part, function, or process which may cause injury must be safeguarded. When the operation of a machine or accidental contact with it can injure the operator or others in the vicinity, the hazards must be either controlled or eliminated.

This manual describes the various hazards of mechanical motion and presents some techniques for protecting workers from these hazards. General information covered in this chapter includes — where mechanical hazards occur, the hazards created by different kinds of motions and the requirements for effective safeguards, as well as a brief discussion of nonmechanical hazards.

Where Mechanical Hazards Occur

Dangerous moving parts in three basic areas require safeguarding:

The point of operation: that point where work is performed on the material, such as cutting, shaping, boring, or forming of stock.

Power transmission apparatus: all components of the mechanical system which transmit energy to the part of the machine performing the work. These components include flywheels, pulleys, belts, connecting rods, couplings, cams, spindles, chains, cranks, and gears.

Other moving parts: all parts of the machine which move while the machine is working. These can include reciprocating, rotating, and transverse moving parts, as well as feed mechanisms and auxiliary parts of the machine.

Hazardous Mechanical Motions and Actions

A wide variety of mechanical motions and actions may present hazards to the worker. These can include the movement of rotating members, reciprocating arms, moving belts, meshing gears, cutting teeth, and any parts that impact or shear. These different types of hazardous mechanical motions and actions are basic in varying combinations to nearly all machines, and recognizing them is the first step toward protecting workers from the danger they present.

The basic types of hazardous mechanical motions and actions are:

Motions

- rotating (including in-running nip points)
- reciprocating
- transversing

Actions

- cutting
- punching
- shearing
- bending

Motions

Rotating motion can be dangerous; even smooth, slowly rotating shafts can grip clothing, and through mere skin contact force an arm or hand into a dangerous position. Injuries due to contact with rotating parts can be severe.

Collars, couplings, cams, clutches, flywheels, shaft ends, spindles, meshing gears, and horizontal or vertical shafting are some examples of common rotating mechanisms which may be hazardous. The danger increases when projections such as set screws, bolts, nicks, abrasions, and projecting keys or set screws are exposed on rotating parts, as shown in Figure 1.

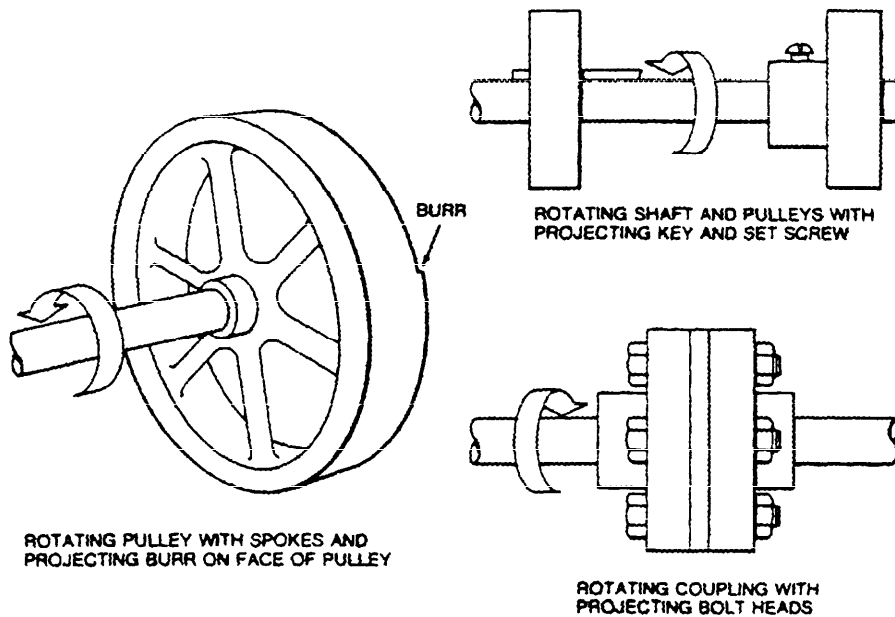
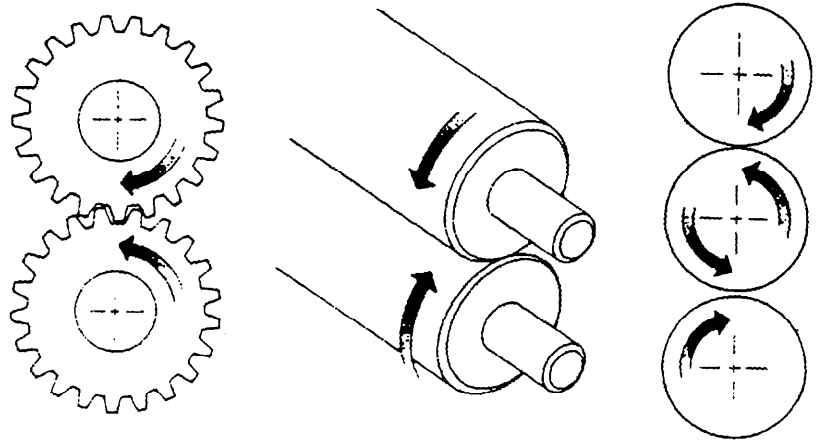

Figure 1.
Examples of hazardous projections on rotating parts

In-running nip point hazards are caused by the rotating parts on machinery. There are three main types of in-running nips.

Parts can rotate in opposite directions while their axes are parallel to each other. These parts may be in contact (producing a nip point) or in close proximity. In the latter case the *stock* fed between the rolls produces the nip points. This danger is common on machines with intermeshing gears, rolling mills, and calenders. See Figure 2.

*Figure 2.
Common nip points on
rotating parts*



Nip points are also created between rotating and tangentially moving parts. Some examples would be: the point of contact between a power transmission belt and its pulley, a chain and a sprocket, and a rack and pinion. See Figure 3.

Nip points can occur between rotating and fixed parts which create a shearing, crushing, or abrading action. Examples are: spoked handwheels or flywheels, screw conveyors, or the periphery of an abrasive wheel and an incorrectly adjusted work rest. See Figure 4.

Reciprocating motions may be hazardous because, during the back-and-forth or up-and-down motion, a worker may be struck by or caught between a moving and a stationary part. See Figure 5 for an example of a reciprocating motion.

Transverse motion (movement in a straight, continuous line) creates a hazard because a worker may be struck or caught in a pinch or shear point by the moving part. See Figure 6.

Actions

Cutting action may involve rotating, reciprocating, or transverse motion. The danger of cutting action exists at the point of operation where finger, arm and body injuries can occur and where flying chips or scrap material can strike the head, particularly in the area of the eyes or face. Such hazards are present at the point of operation in cutting wood, metal, or other materials.

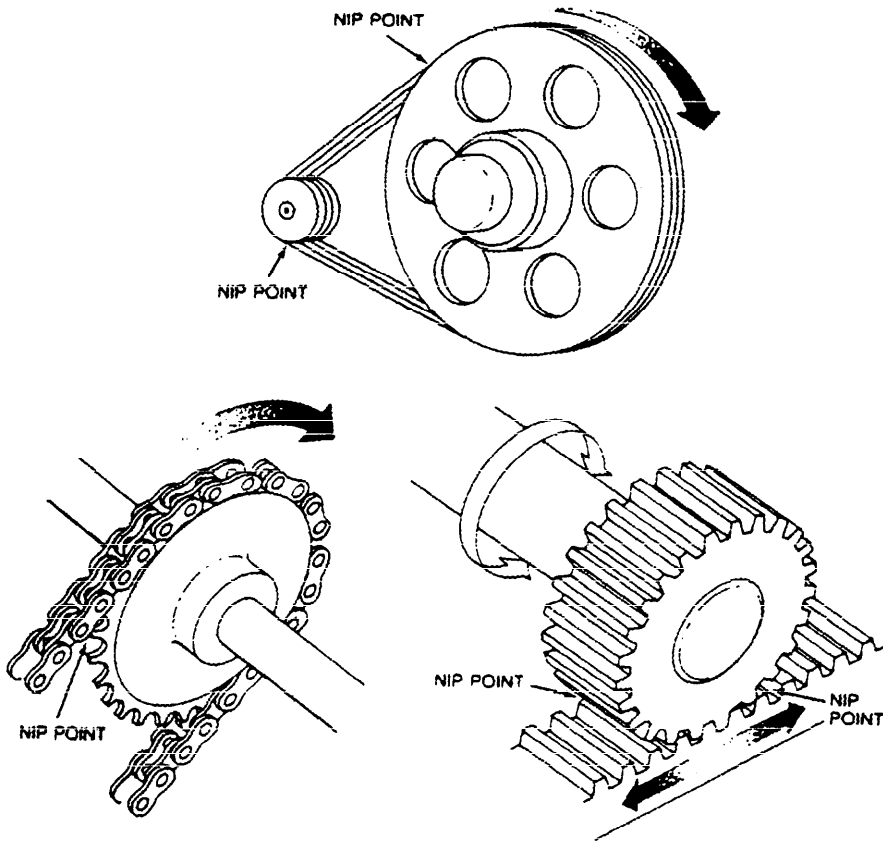

Figure 3.
Nip points between rotating elements and parts with longitudinal motions

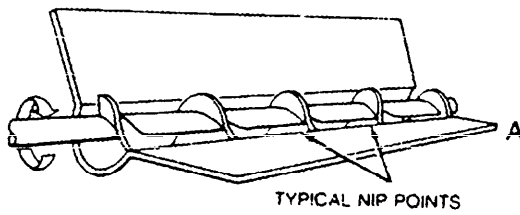

Figure 4.
Nip points between rotating machine components;
(A— cover removed for clarity.)

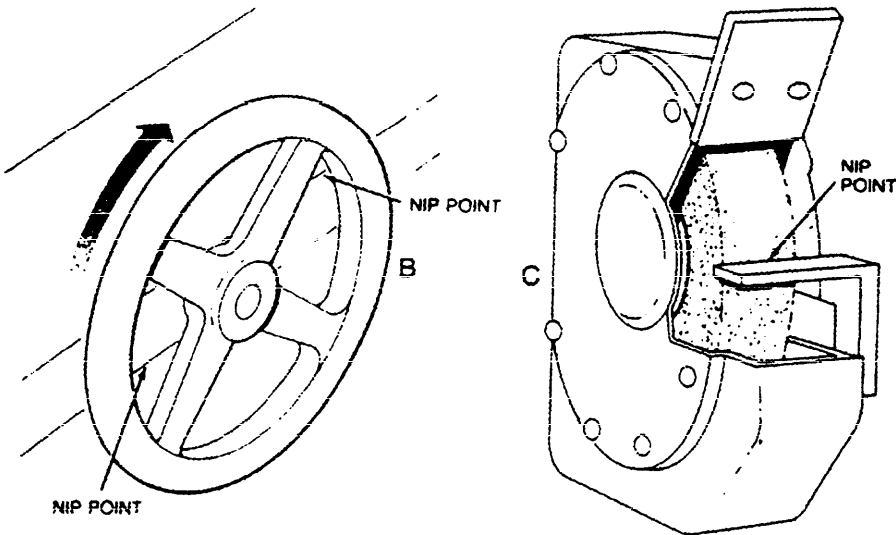

Figure 5.
Hazardous reciprocating motion

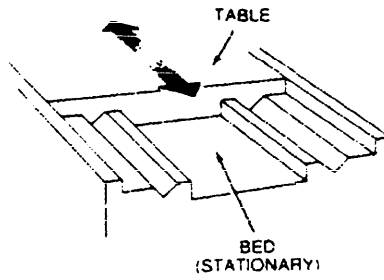
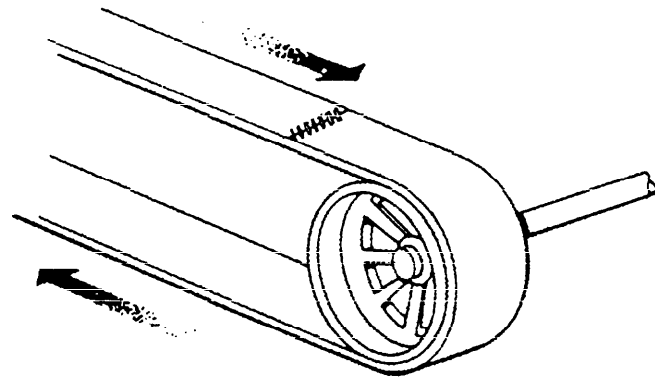
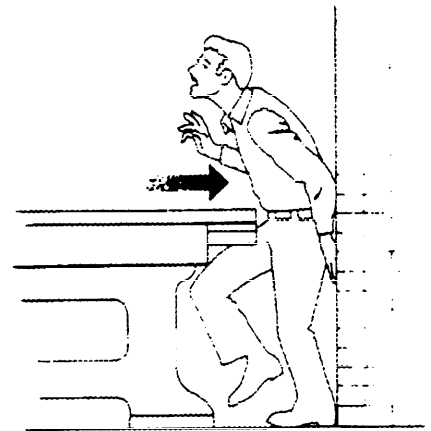
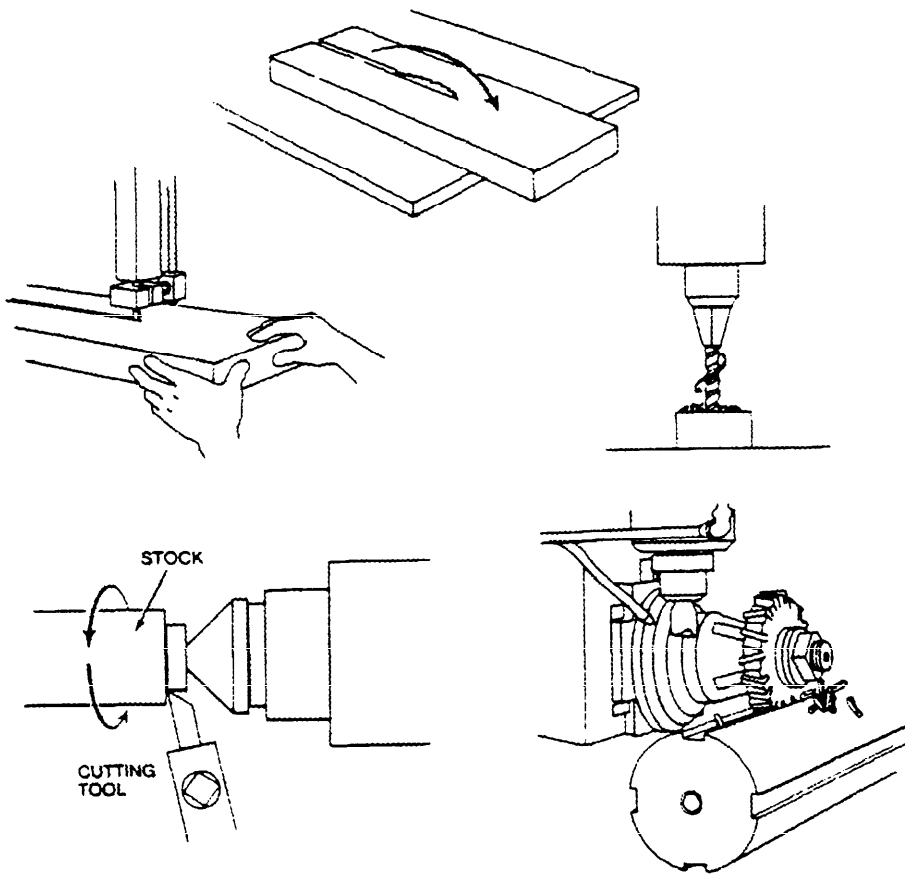

Figure 6.
Example of transverse motion



TRANSVERSE MOTION OF BELT



*Figure 7.
Examples of dangerous
cutting hazards*

Examples of mechanisms involving cutting hazards include bandsaws, circular saws, boring or drilling machines, turning machines (lathes), or milling machines. See Figure 7.

Punching action results when power is applied to a slide (ram) for the purpose of blanking, drawing, or stamping metal or other materials. The danger of this type of action occurs at the point of operation where stock is inserted, held, and withdrawn by hand.

Typical machines used for punching operations are power presses and iron workers. See Figure 8.

Shearing action involves applying power to a slide or knife in order to trim or shear metal or other materials. A hazard occurs at the point of operation where stock is actually inserted, held, and withdrawn.

Examples of machines used for shearing operations are mechanically, hydraulically, or pneumatically powered shears. See Figure 9.

Bending action results when power is applied to a slide in order to draw or stamp metal or other materials. A hazard occurs at the point of operation where stock is inserted, held, and withdrawn.

Equipment that uses bending action includes power presses, press brakes, and tubing benders. See Figure 10.

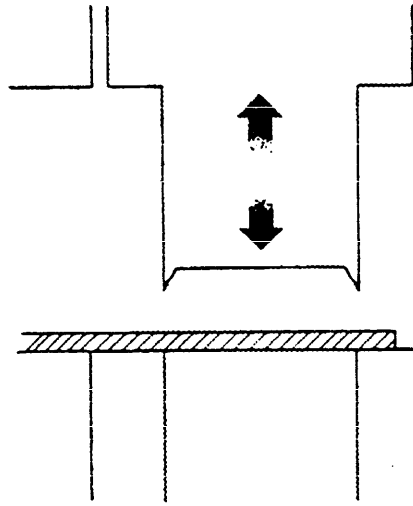

Figure 8.
Typical punching operation

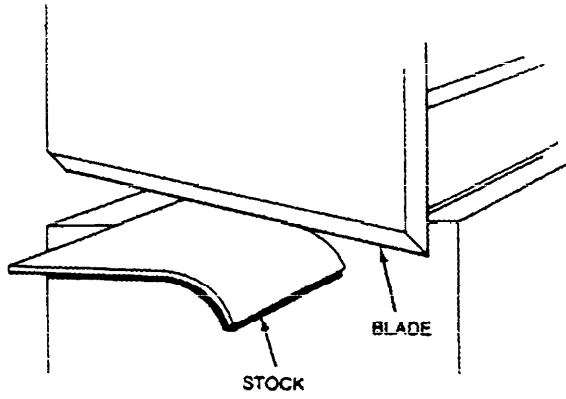

Figure 9.
Shearing

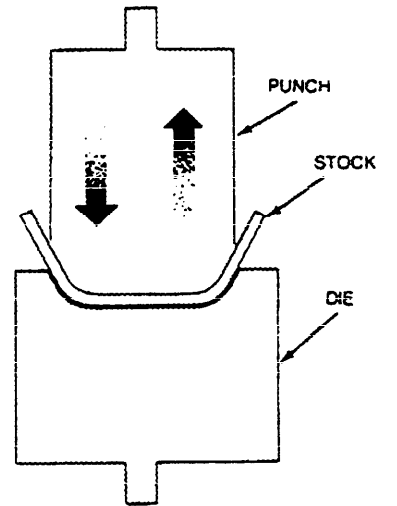

Figure 10.
Bending

Requirements for Safeguards

What must a safeguard do to protect workers against mechanical hazards? Safeguards must meet these minimum general requirements:

Prevent contact: The safeguard must prevent hands, arms, and any other part of a worker's body from making contact with dangerous moving parts. A good safeguarding system eliminates the possibility of the operator or another worker placing parts of their bodies near hazardous moving parts.

Secure: Workers should not be able to easily remove or tamper with the safeguard, because a safeguard that can easily be made ineffective is no safeguard at all. Guards and safety devices should be made of durable material that will withstand the conditions of normal use. They must be firmly secured to the machine.

Protect from falling objects: The safeguard should ensure that no objects can fall into moving parts. A small tool which is dropped into a cycling machine could easily become a projectile that could strike and injure someone.

Create no new hazards: A safeguard defeats its own purpose if it creates a hazard of its own such as a shear point, a jagged edge, or an unfinished surface which can cause a laceration. The edges of guards, for instance, should be rolled or bolted in such a way that they eliminate sharp edges.

Create no interference: Any safeguard which impedes a worker from performing the job quickly and comfortably might soon be overridden or disregarded. Proper safeguarding can actually enhance efficiency since it can relieve the worker's apprehensions about injury.

Allow safe lubrication: If possible, one should be able to lubricate the machine without removing the safeguards. Locating oil reservoirs outside the guard, with a line leading to the lubrication point, will reduce the need for the operator or maintenance worker to enter the hazardous area.

Nonmechanical Hazards

While this manual concentrates attention on concepts and techniques for safeguarding mechanical motion, machines obviously present a variety of other hazards which cannot be ignored. Full discussion of these matters is beyond the scope of this publication, but some nonmechanical hazards are briefly mentioned below to remind the reader of things other than safeguarding moving parts that can affect the safe operation of machines.

All power sources for machines are potential sources of danger. When using electrically powered or controlled machines, for instance, the equipment as well as the electrical system itself must be properly grounded. Replacing frayed, exposed, or old wiring will also help to protect the operator and others from electrical shocks or electrocution. High pressure systems, too, need careful inspection and maintenance to prevent possible failure from pulsation, vibration, or leaks. Such a failure could cause, among other things, explosions or flying objects.

Machines often produce noise (unwanted sound) which can result in a number of hazards to workers. Noise can startle and disrupt concentration, and can interfere with communications, thus hindering the worker's safe job performance. Research has linked noise to a whole range of harmful health effects, from hearing loss and aural pain to nausea, fatigue, reduced muscle control, and emotional disturbance. Engineering controls such as the use of sound-dampening materials, and personal protective equipment, such as ear plugs and muffs, can help control the harmful effects of noise. Also, administrative controls that involve removing the worker from the noise source can be an effective measure when feasible.

Because some machines require the use of cutting fluids, coolants, and other potentially harmful substances, operators, maintenance workers, and others in the vicinity may need protection. These substances can cause ailments ranging from dermatitis to serious illnesses and disease. Specially constructed safeguards, ventilation, and protective equipment and clothing are possible temporary solutions to the problem of machinery-related chemical hazards until these hazards can be better controlled or eliminated from the workplace.

Training

Even the most elaborate safeguarding system cannot offer effective protection unless the worker knows how to use it and why. Specific and detailed training is therefore a crucial part of any effort to provide safeguarding against machine-related hazards. Thorough operator training should involve instruction or hands-on training in the following:

- (1) a description and identification of the hazards associated with particular machines;
- (2) the safeguards themselves, how they provide protection, and the hazards for which they are intended;
- (3) how to use the safeguards and why;
- (4) how and under what circumstances safeguards can be removed, and by whom (in most cases, repair or maintenance personnel only); and
- (5) what to do (e.g., contact the supervisor) if a safeguard is damaged, missing, or unable to provide adequate protection.

This kind of safety training is necessary for new operators and maintenance or setup personnel, when any new or altered safeguards are put in service, or when workers are assigned to a new machine or operation.

Protective Clothing and Personal Protective Equipment

Engineering controls, that eliminate the hazard at the source and do not rely on the worker's behavior for their effectiveness offer the best and most reliable means of safeguarding. Therefore, engineering controls must be the employer's first choice for eliminating machine hazards. But whenever engineering controls are not available or are not fully capable of protecting the employee (an extra measure of protection is necessary), operators must wear protective clothing or personal protective equipment.

If it is to provide adequate protection, the protective clothing and equipment selected must always be:

- (1) appropriate for the particular hazards;
- (2) maintained in good condition;
- (3) properly stored when not in use, to prevent damage or loss; and
- (4) kept clean, fully functional, and sanitary.

Protective clothing is, of course, available for different parts of the body. Hard hats can protect the head from the impact of bumps and falling objects when the worker is handling stock; caps and hair nets can help keep the worker's hair from being caught in machinery. If machine coolants could splash or particles could fly into the operator's eyes or face, then face shields, safety goggles, glasses, or similar kinds of protection might be necessary. Hearing protection may be needed when workers operate noisy machines. To guard the trunk of the body from cuts or impacts from heavy or rough-edged stock, there are certain protective coveralls, jackets, vests, aprons, and full-body suits. Workers can protect their hands and arms from the same kinds of injury with special sleeves and gloves. Safety shoes and boots, or other acceptable foot guards, can shield the feet against injury in case the worker needs to handle heavy stock which might drop.

It is important to note that protective clothing and equipment can create hazards. A protective glove which can become caught between rotating parts, or a respirator facepiece which hinders the wearer's vision, for example, require alertness and continued attentiveness whenever they are used.

Other parts of the worker's clothing may present additional safety hazards. For example, loose-fitting shirts might possibly become entangled in rotating spindles or other kinds of moving machinery. Jewelry, such as bracelets and rings, can catch on machine parts or stock and lead to serious injury by pulling a hand into the danger area.

Methods of Machine Safeguarding

There are many ways to safeguard machines. The type of operation, the size or shape of stock, the method of handling, the physical layout of the work area, the type of material, and production requirements or limitations will help to determine the appropriate safeguarding method for the individual machine.

As a general rule, power transmission apparatus is best protected by fixed guards that enclose the danger areas. For hazards at the point of operation, where moving parts actually perform work on stock, several kinds of safeguarding may be possible. One must always choose the most effective and practical means available.

We can group safeguards under five general classifications.

1. Guards
 - A. Fixed
 - B. Interlocked
 - C. Adjustable
 - D. Self-adjusting
2. Devices
 - A. Presence Sensing
 - (1) Photoelectrical (optical)
 - (2) Radiofrequency (capacitance)
 - (3) Electromechanical
 - B. Pullback
 - C. Restraint
 - D. Safety Controls
 - (1) Safety trip control
 - (a) Pressure-sensitive body bar
 - (b) Safety tripod
 - (c) Safety tripwire cable
 - (2) Two-hand control
 - (3) Two-hand trip
 - E. Gates
 - (1) Interlocked
 - (2) Other
3. Location/Distance
4. Potential Feeding and Ejection Methods to Improve Safety for the Operator
 - A. Automatic feed
 - B. Semi-automatic feed
 - C. Automatic ejection
 - D. Semi-automatic ejection

- E. Robot
- 5. Miscellaneous Aids
 - A. Awareness barriers
 - B. Miscellaneous protective shields
 - C. Hand-feeding tools and holding fixtures

Guards

Guards are barriers which prevent access to danger areas. There are four general types of guards:

Fixed: As its name implies, a fixed guard is a permanent part of the machine. It is not dependent upon moving parts to perform its intended function. It may be constructed of sheet metal, screen, wire cloth, bars, plastic, or any other material that is substantial enough to withstand whatever impact it may receive and to endure prolonged use. This guard is usually preferable to all other types because of its relative simplicity and permanence.

Examples of fixed guards...

In Figure 11, a fixed guard on a power press completely encloses the point of operation. The stock is fed through the side of the guard into the die area, with the scrap stock exiting on the opposite side.

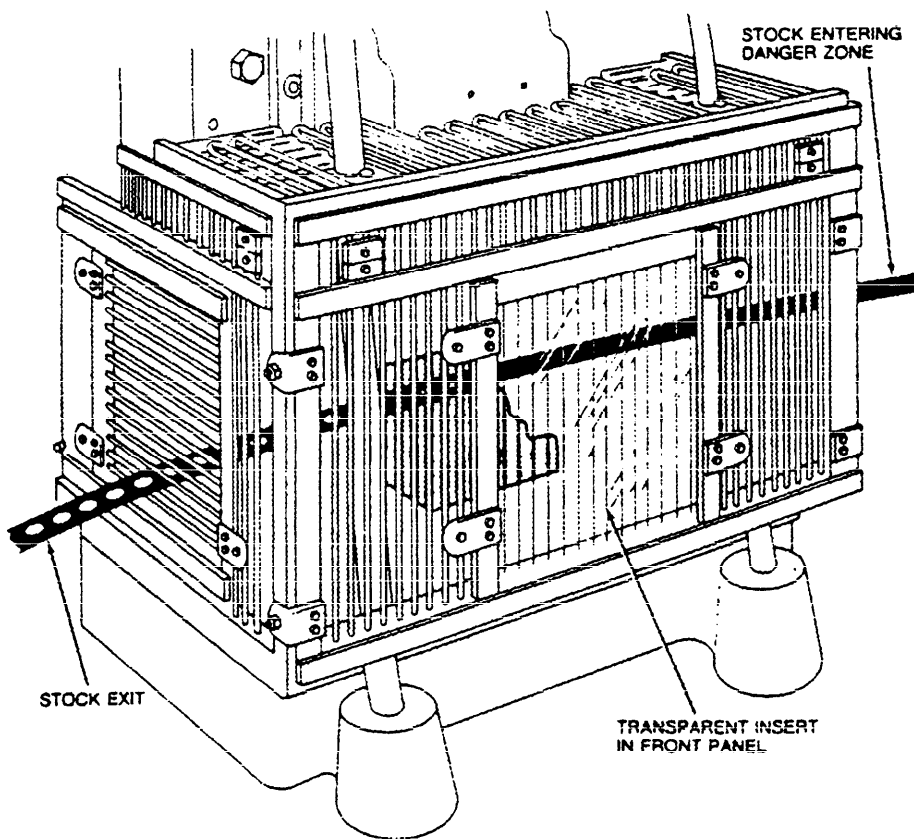
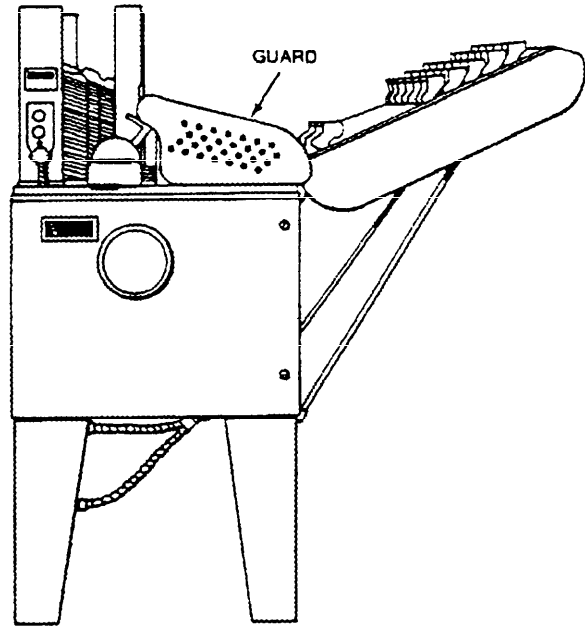

Figure 11.
Fixed guard on power press

Figure 12 shows a fixed guard that protects the operator from a mechanism that folds cartons. This guard would not normally be removed except to perform maintenance on the machine. Figure 13 shows a fixed enclosure guard shielding the belt and pulley of a power transmission unit. An inspection panel is provided on top in order to minimize the need for removing the guard. To remain effective, the inspection panel cannot be removed while the mechanism is in operation. In Figure 14, fixed enclosure guards are shown on a bandsaw. These guards protect the operator from the turning wheels and moving saw blade. Normally, the only time for the guards to be opened or removed would be for a blade change or maintenance. It is very important that they be securely fastened while the saw is in use.

*Figure 12.
Fixed guard on egg
carton folding machine*



*Figure 13.
Fixed guard enclosing
belt and pulleys*

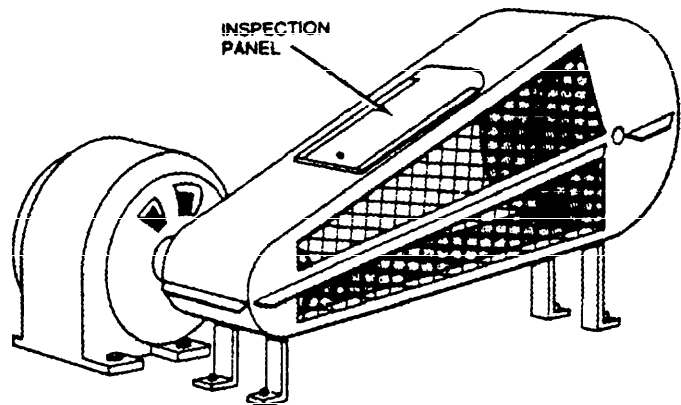

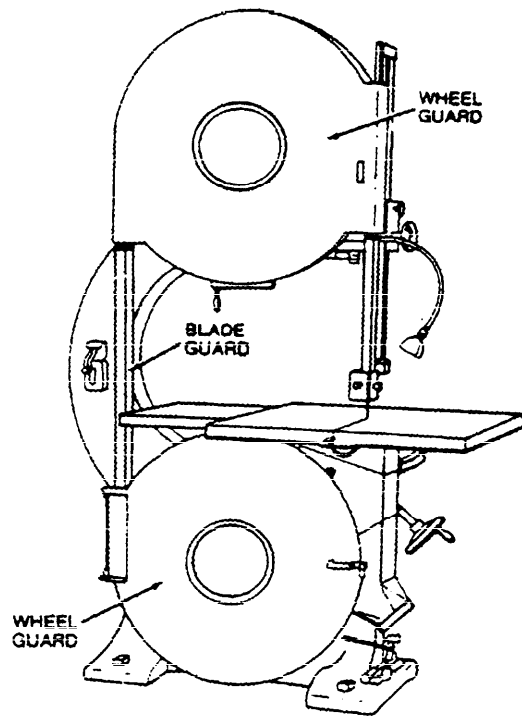

Figure 14.
Fixed guards on a band saw

A fixed guard is shown on a veneer clipper in Figure 15. This guard acts as a barrier, protecting fingers from exposure to the blade. Note the side view of the curved portion of the guard.

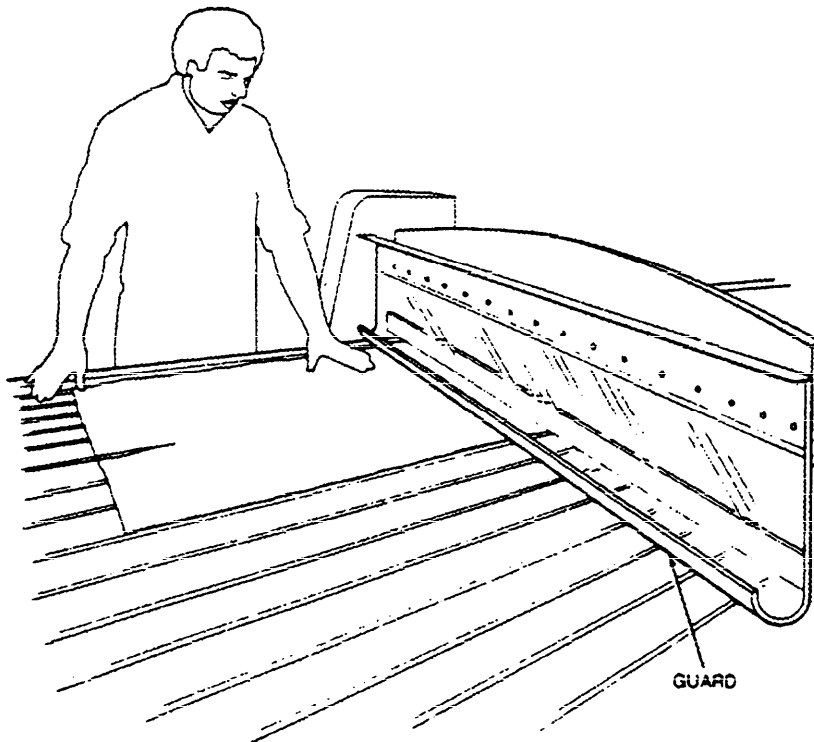
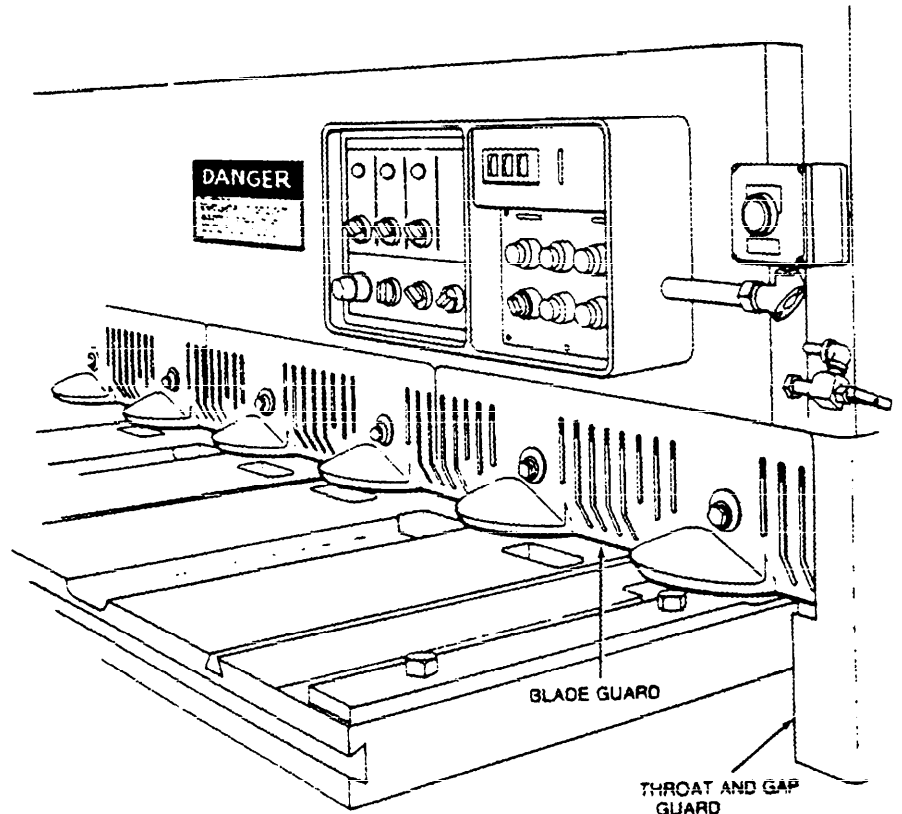
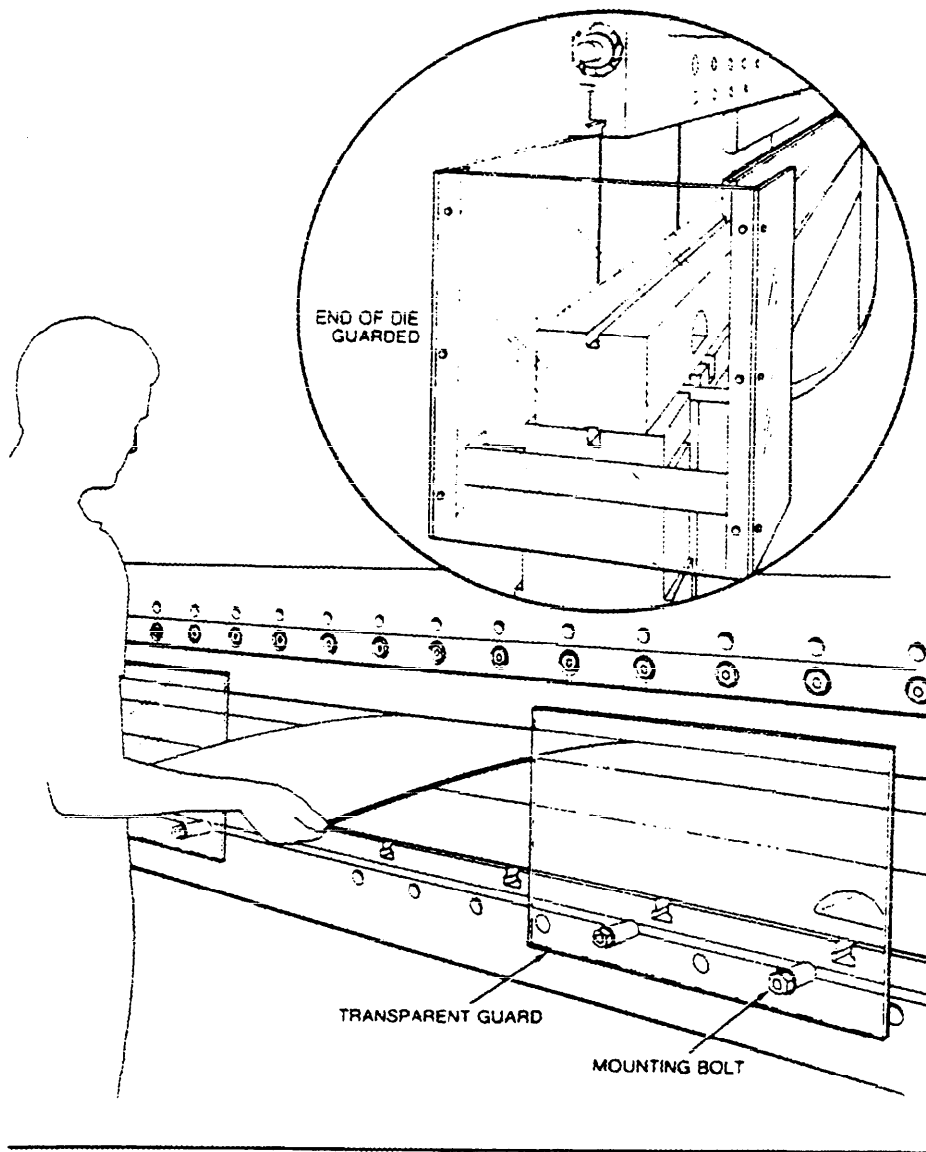

Figure 15.
Fixed guards on veneer clipper



*Figure 16.
Fixed guard on a power
squaring shear*

Figure 16 shows both a fixed blade guard and a throat and gap guard on a power squaring shear. These guards should be removed only for maintenance or blade changes.



*Figure 17.
Fixed guard providing
protection from unused portion
of die on a press brake*

In Figure 17, a transparent, fixed barrier guard is being used on a press brake to protect the operator from the unused portions of the die. This guard is easy to install or remove.

Interlocked: When this type of guard is opened or removed, the tripping mechanism and/or power automatically shuts off or disengages, and the machine cannot cycle or be started until the guard is back in place.

An interlocked guard may use electrical, mechanical, hydraulic, or pneumatic power or any combination of these. Interlocks should not prevent "inching" by remote control if required. Replacing the guard should not automatically restart the machine. To be effective, all movable guards should be interlocked to prevent occupational hazards.

(See also Figure 13.)

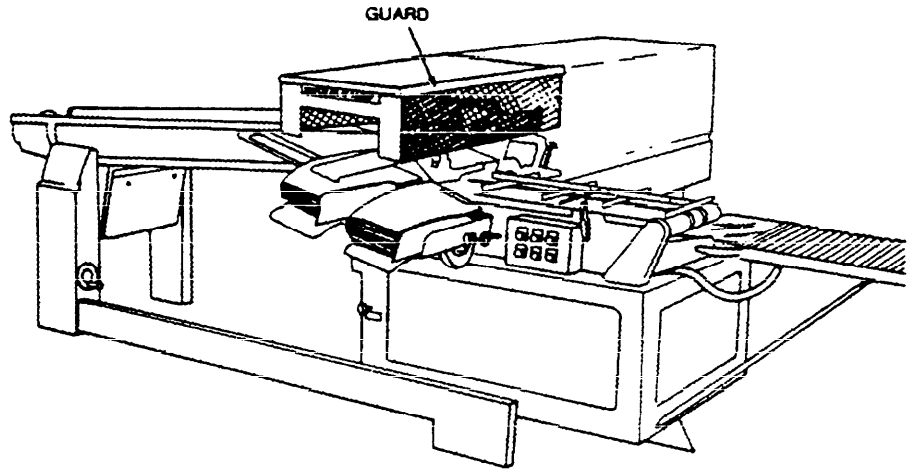
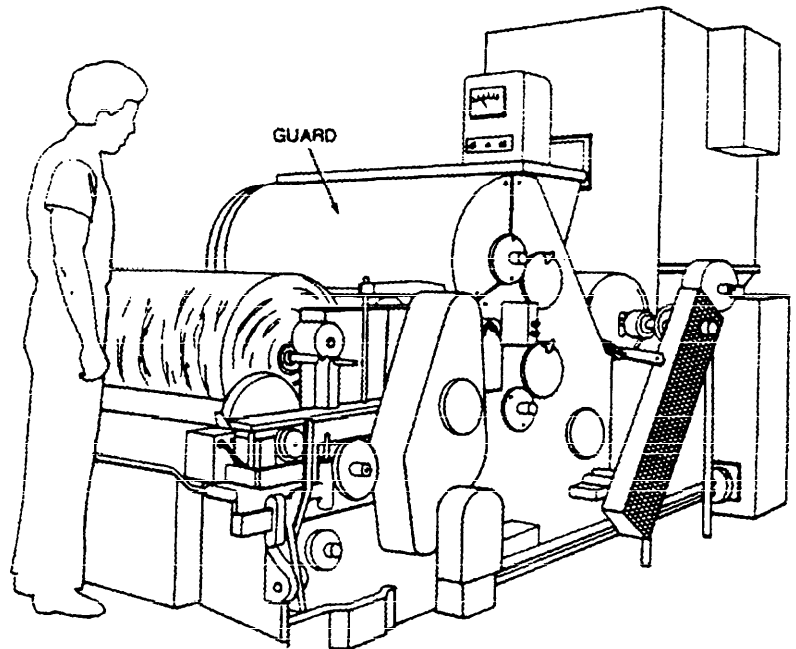

*Figure 18.
Interlocked guard on automatic
bread bagging machine*

Figure 18 shows an interlocked barrier guard mounted on an automatic bread bagging machine. When the guard is removed, the machine will not function.

In Figure 19, the beater mechanism of a picker machine (used in the textile industry) is covered by an interlocked barrier guard. This guard cannot be raised while the machine is running, nor can the machine be restarted with the guard in the raised position.

*Figure 19.
Interlocked guard on
picker machine*



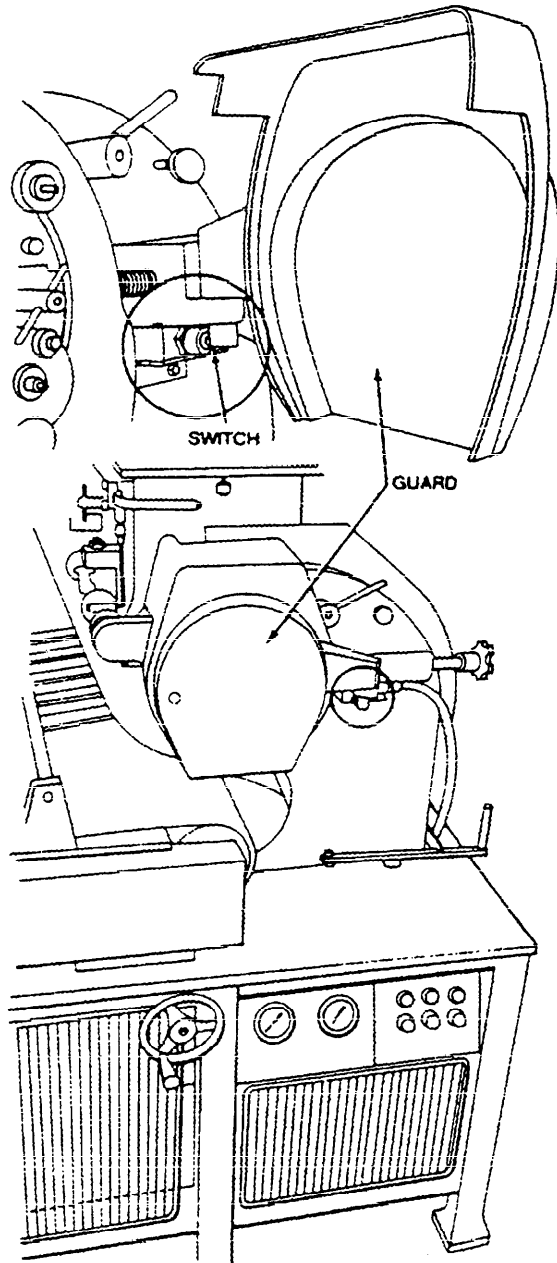
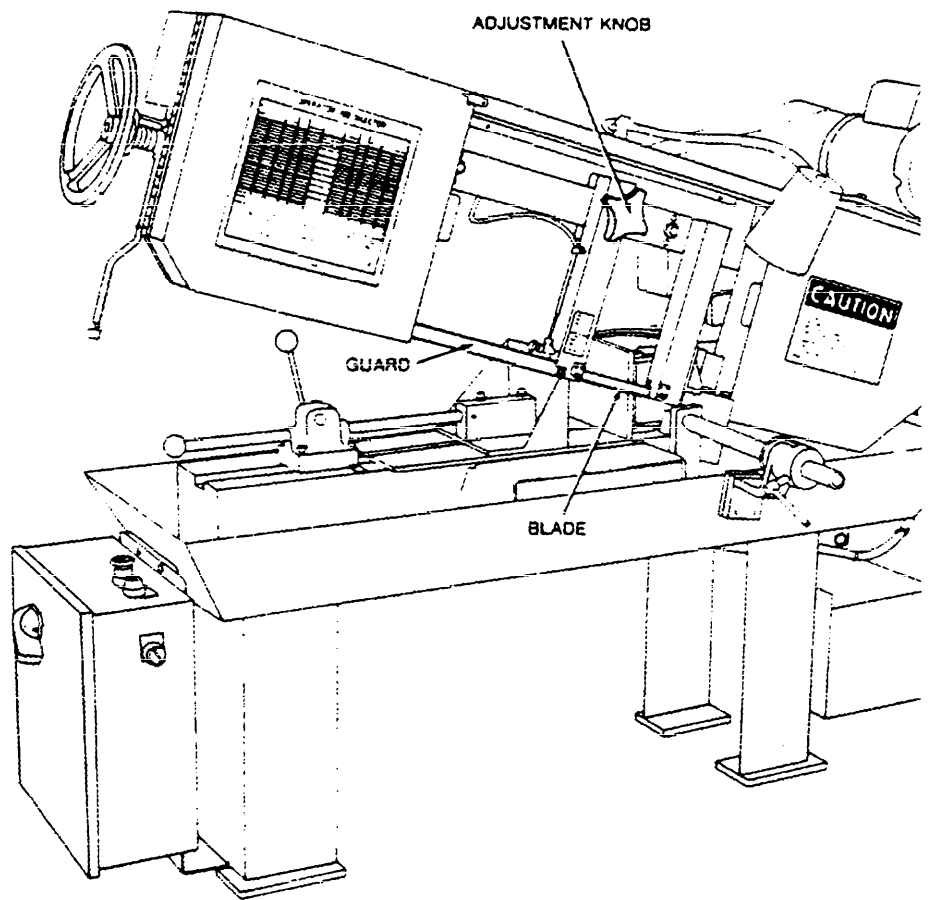

*Figure 20.
Interlocked guard on roll
make-up machine*

In Figure 20, an interlocked guard covers the rotating cylinder of the dividing head of a roll make-up machine used for making hamburger and hot-dog rolls.

Adjustable: Adjustable guards are useful because they allow flexibility in accommodating various sizes of stock.

Figure 21 shows a bandsaw with an adjustable guard to protect the operator from the unused portion of the blade. This guard can be adjusted according to the size of stock.



*Figure 21.
Adjustable guard on
horizontal bandsaw*

In Figure 22, the bars adjust to accommodate the size and shape of the stock. Figures 23 and 24 show guards that can be adjusted according to the thickness of the stock.

In Figure 25, the guard adjusts to provide a barrier between the operator and the blade.

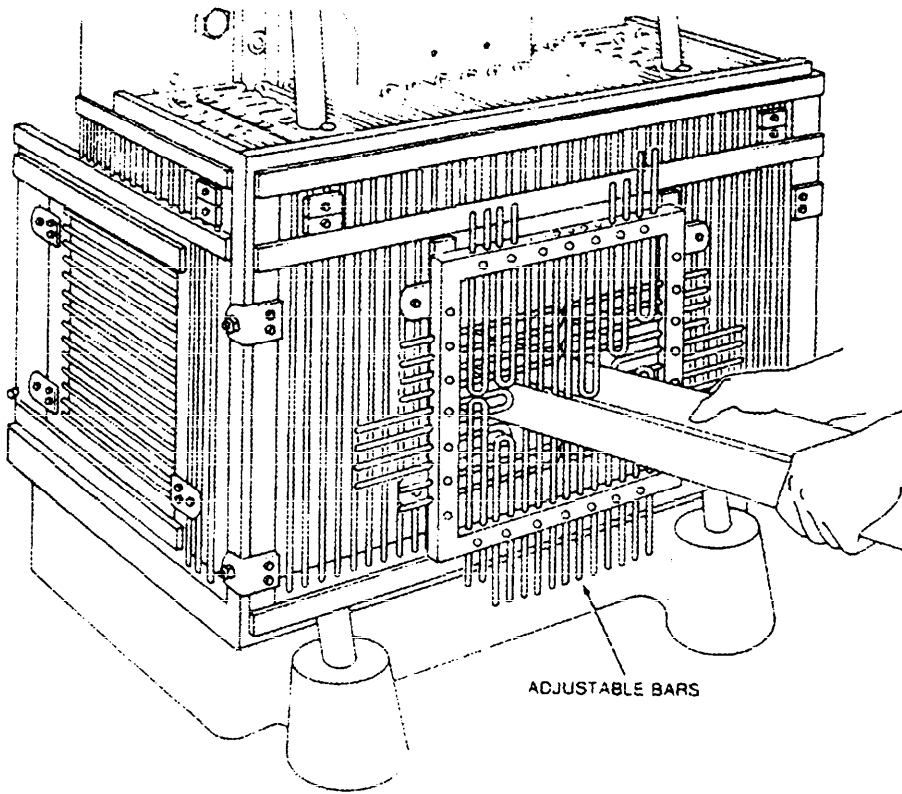

Figure 22.
Adjustable guard on
power press

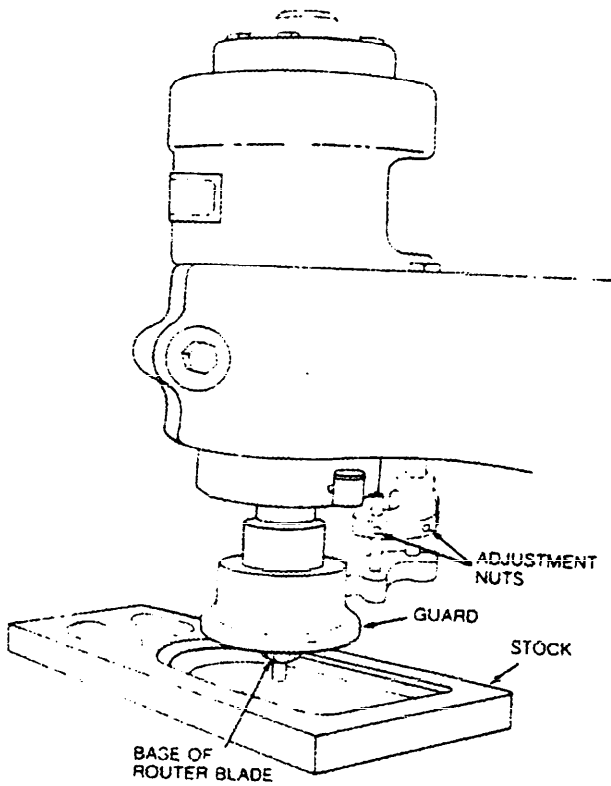

Figure 23.
Adjustable guard
on router

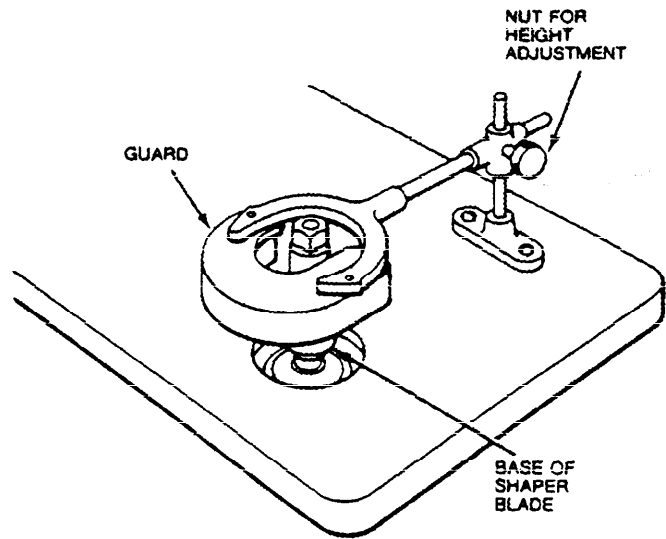
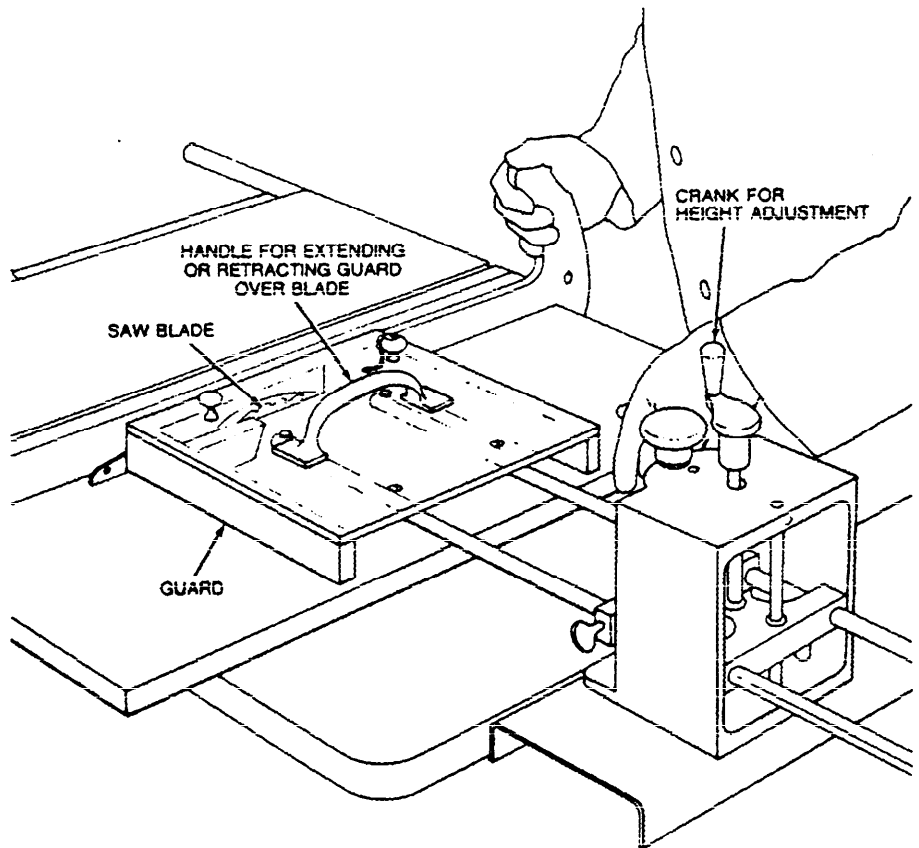

Figure 24.
Adjustable guard on shaper

Figure 25.
Adjustable guard on table saw



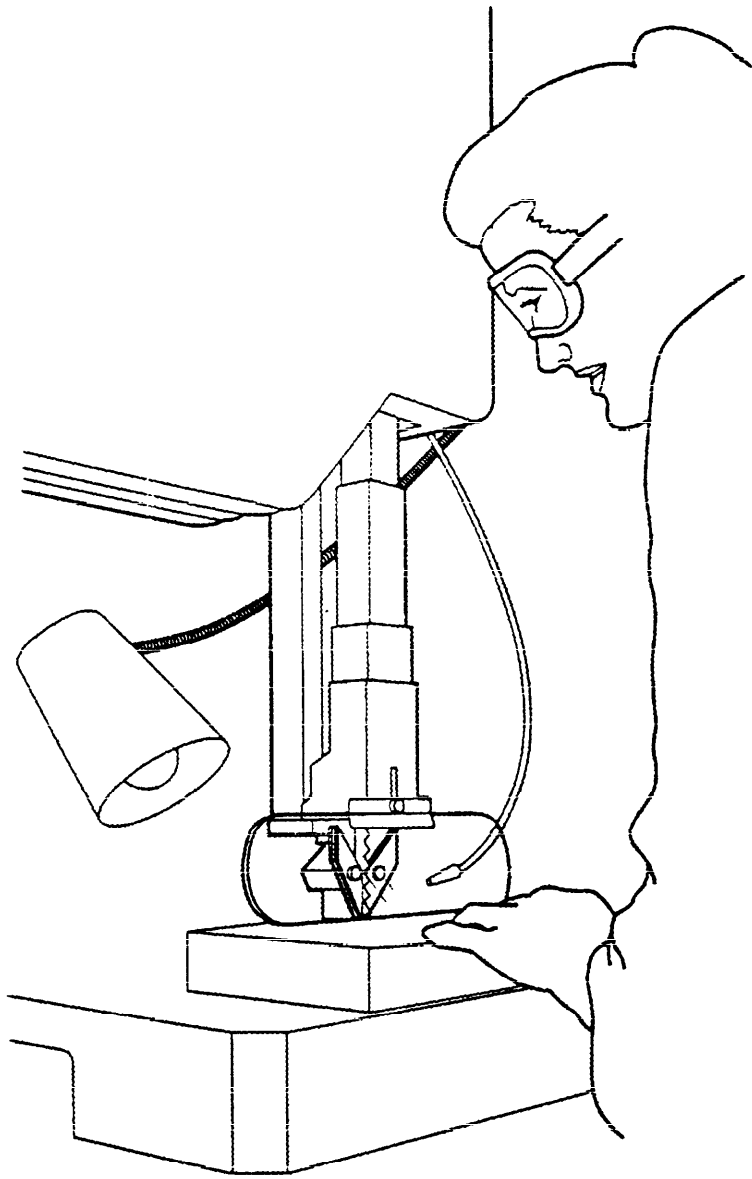

Figure 26.
Adjustable guard on bandsaw

Figure 26 shows an adjustable enclosure guard on a bandsaw.

Self-Adjusting: The openings of these barriers are determined by the movement of the stock. As the operator moves the stock into the danger area, the guard is pushed away, providing an opening which is only large enough to admit the stock. After the stock is removed, the guard returns to the rest position. This guard protects the operator by placing a barrier between the danger area and the operator. The guards may be constructed of plastic, metal, or other substantial material. Self-adjusting guards offer different degrees of protection.

Examples of self-adjusting guards...

Figure 27 shows a radial arm saw with a self-adjusting guard. As the blade is pulled across the stock, the guard moves up, staying in contact with the stock.

Figure 28 shows a twin-action, transparent, self-adjusting guard. The first guard rises as the stock enters, then returns to its rest position as the stock moves ahead to raise the second guard.

A self-adjusting guard is shown in Figure 29. As the blade moves through the stock, the guard rises up to the stock surface.

*Figure 27.
Self-adjusting guard on
radial arm saw*

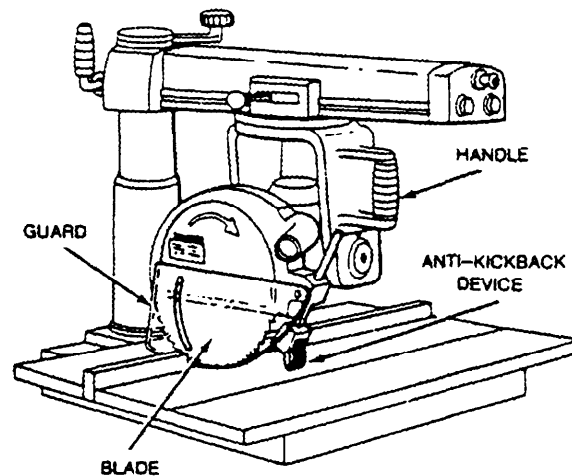

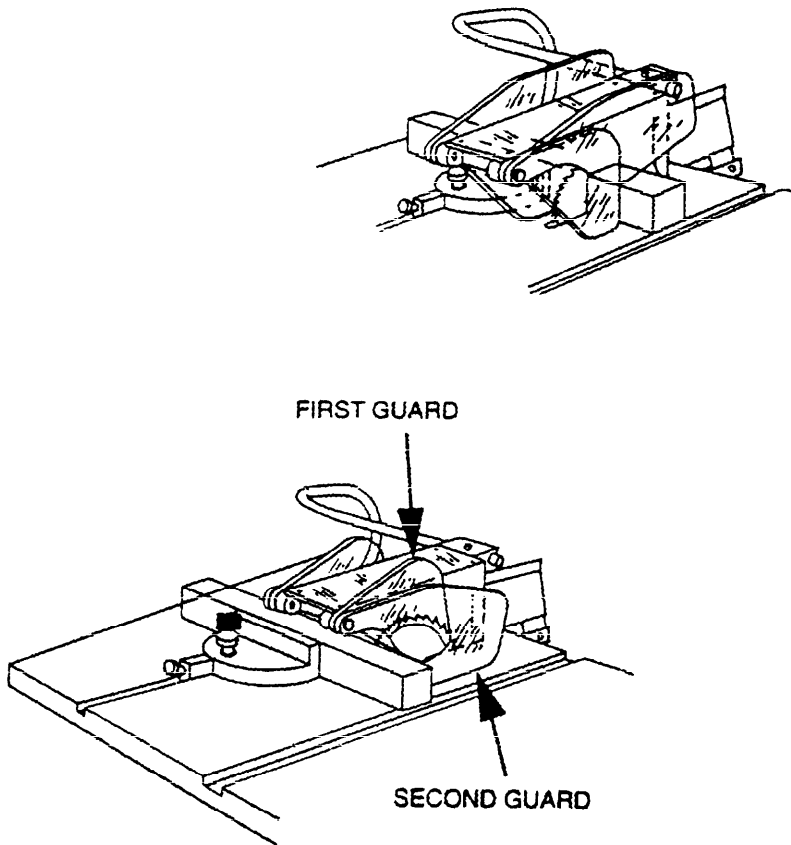

Figure 28.
Self-adjusting guard on
table saw

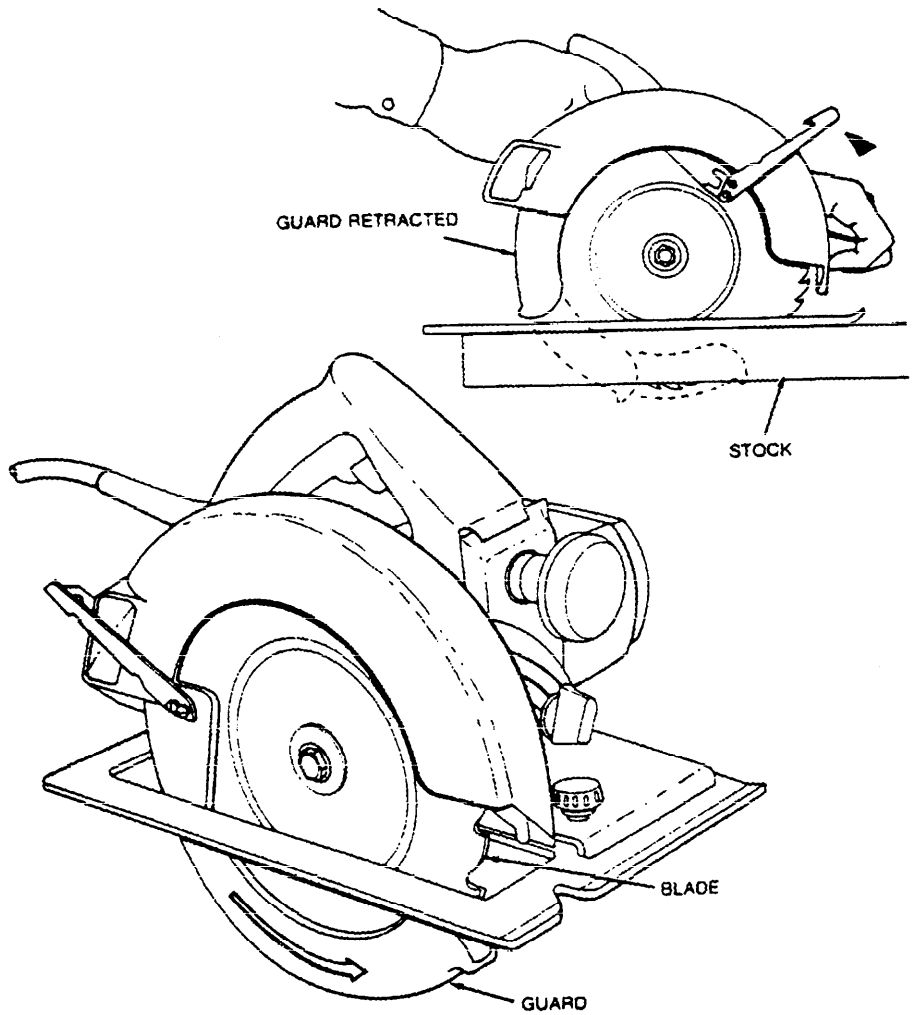

Figure 29.
Self-adjusting guard on
circular saw

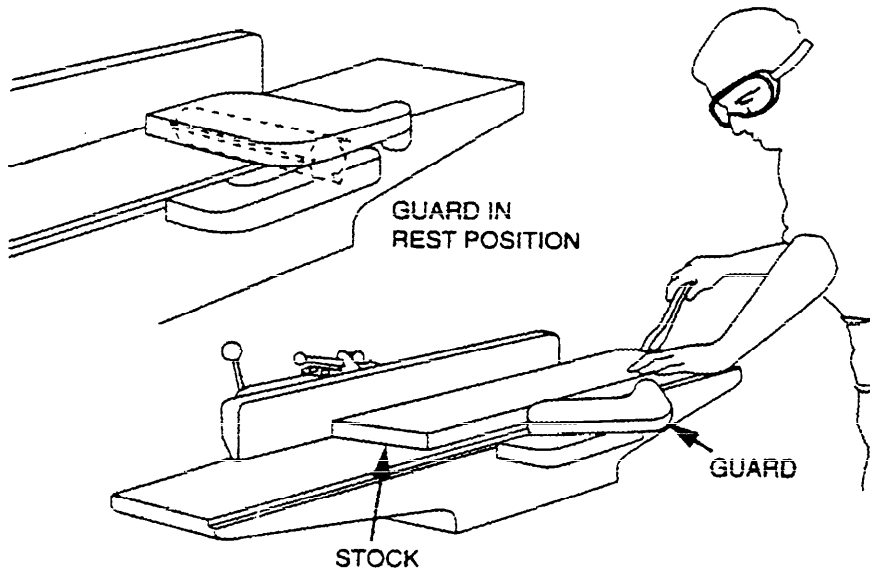

Figure 30.
Self-adjusting guard on
a jointer

Figure 30 shows a self-adjusting enclosure guard mounted on a jointer. This guard is moved from the cutting head by the stock. After the stock is removed, the guard will return, under spring tension, to the rest position.

Another type of self-adjusting guard mounted on a jointer is illustrated in Figure 31. The guard moves two ways. An edging operation causes the guard to move horizontally. If the stock is wide enough during a surfacing operation, the stock may be fed under the guard, causing it to move vertically.

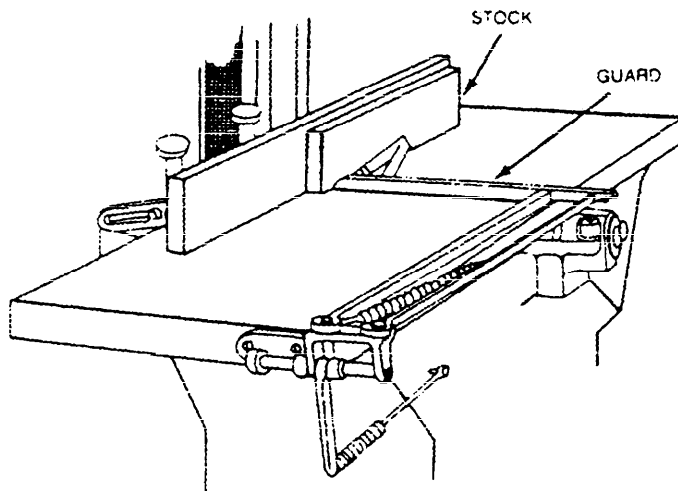

Figure 31.
Self-adjusting guard on
a jointer

Guards

Method	Safeguarding Action	Advantages	Limitations
Fixed	Provides a barrier	<p>Can be constructed to suit many specific applications</p> <p>In-plant construction is often possible</p> <p>Can provide maximum protection</p> <p>Usually requires minimum maintenance</p> <p>Can be suitable to high production, repetitive operations</p>	<p>May interfere with visibility</p> <p>Can be limited to specific operations</p> <p>Machine adjustment and repair often require its removal, thereby necessitating other means of protection for maintenance personnel</p>
Interlocked	Shuts off or disengages power and prevents starting of machine when guard is open; should require the machine to be stopped before the worker can reach into the danger area	<p>Can provide maximum protection</p> <p>Allows access to machine for removing jams without time consuming removal of fixed guards</p>	<p>Requires careful adjustment and maintenance</p> <p>May be easy to disengage jams</p>
Adjustable	Provides a barrier that may be adjusted to facilitate a variety of production operations	<p>Can be constructed to suit many specific applications</p> <p>Can be adjusted to admit varying sizes of stock</p>	<p>Hands may enter danger area — protection may not be complete at all times</p> <p>May require frequent maintenance and/or adjustment</p> <p>The guard may be made ineffective by the operator</p> <p>May interfere with visibility</p>
Self-adjusting	Provides a barrier that moves according to the size of the stock entering the danger area	Off-the-shelf guards are often commercially available	<p>Does not always provide maximum protection</p> <p>May interfere with visibility</p> <p>May require frequent maintenance and adjustment</p>

Devices

A safety device may perform one of several functions. It may stop the machine if a hand or any part of the body is inadvertently placed in the danger area; restrain or withdraw the operator's hands from the danger area during operation; require the operator to use both hands on machine controls, thus keeping both hands and body out of danger; or provide a barrier which is synchronized with the operating cycle of the machine in order to prevent entry to the danger area during the hazardous part of the cycle.

Presence-Sensing

The photoelectric (optical) presence-sensing device uses a system of light sources and controls which can interrupt the machine's operating cycle. If the light field is broken, the machine stops and will not cycle. This device must be used only on machines which can be stopped before the worker can reach the danger area. The design and placement of the guard depends upon the time it takes to stop the mechanism and the speed at which the employee's hand can reach across the distance from the guard to the danger zone.

Figure 32 shows a photoelectric presence-sensing device on a part-revolution power press. When the light beam is broken, either the ram will not start to cycle, or, if the cycle has begun, the stopping mechanism will be

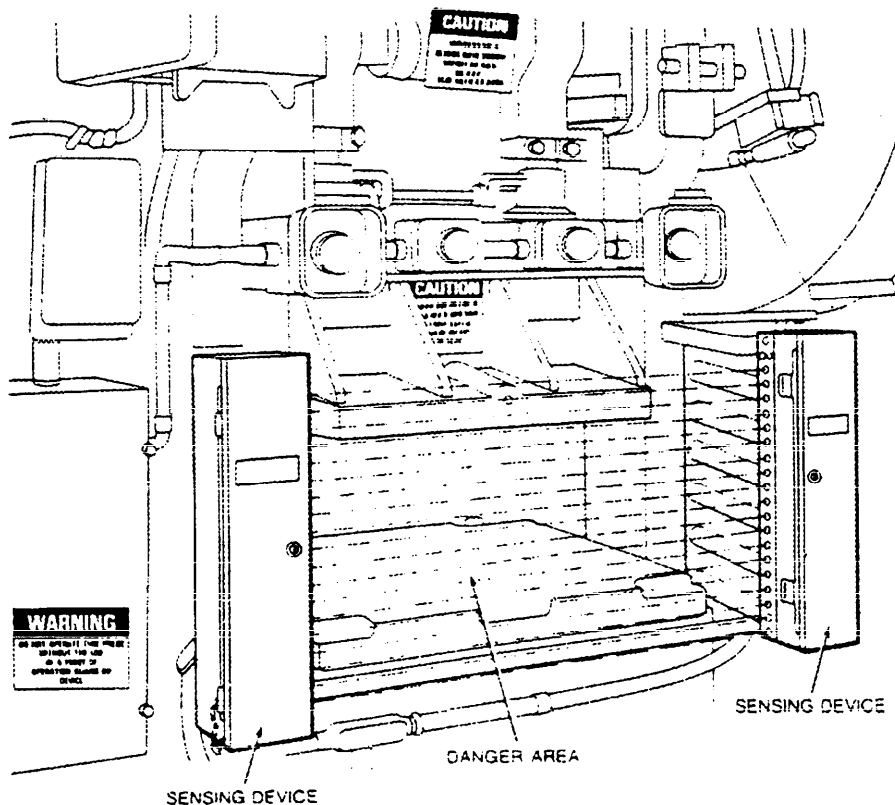

Figure 32.
Photoelectric presence-sensing
device on power press

activated so that the press stops before the operator's hand can enter the danger zone.

A photoelectric presence-sensing device used with a press brake is illustrated in Figure 33. The device may be swung up or down to accommodate different production requirements.

The radiofrequency (capacitance) presence-sensing device uses a radio beam that is part of the machine control circuit. When the capacitance field is broken, the machine will stop or will not activate. Like the photoelectric device, this device shall only be used on machines which can be stopped before the worker can reach the danger area. This requires the machine to have a friction clutch or other reliable means for stopping.

Figure 34 shows a radiofrequency presence-sensing device mounted on a part-revolution power press.

The electromechanical sensing device has a probe or contact bar which descends to a predetermined distance when the operator initiates the machine cycle. If there is an obstruction preventing it from descending its full predetermined distance, the control circuit does not actuate the machine cycle.

Figure 35 shows an electromechanical sensing device on an eyeletter. The sensing probe in contact with the operator's finger is also shown.

*Figure 33.
Photoelectric presence-sensing
device on press brake*

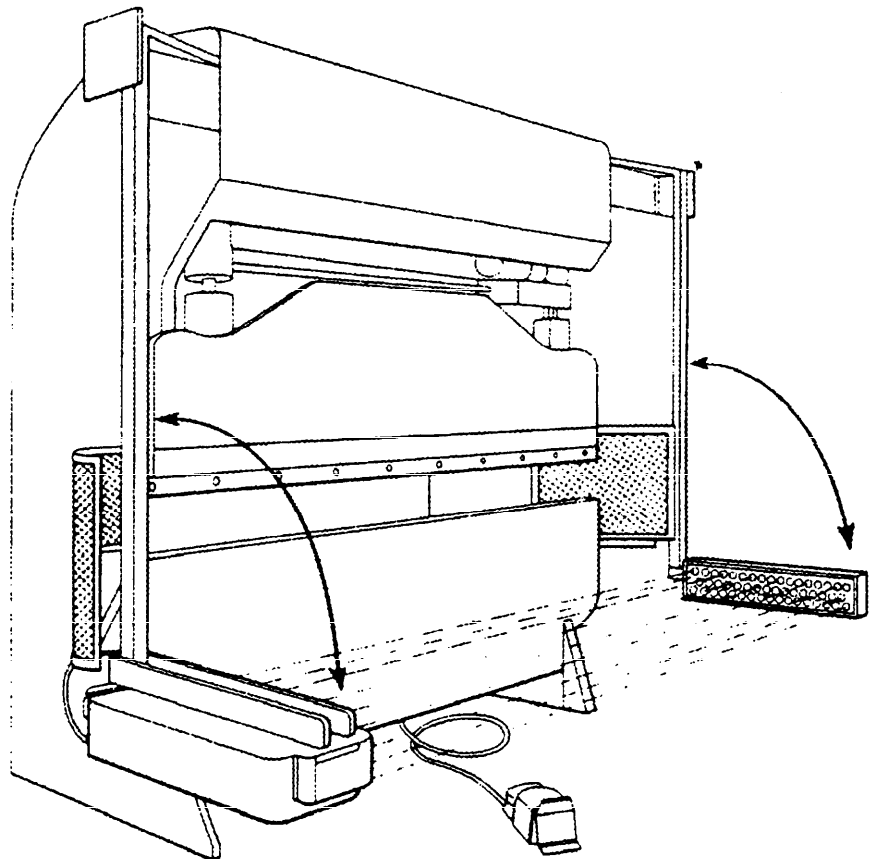

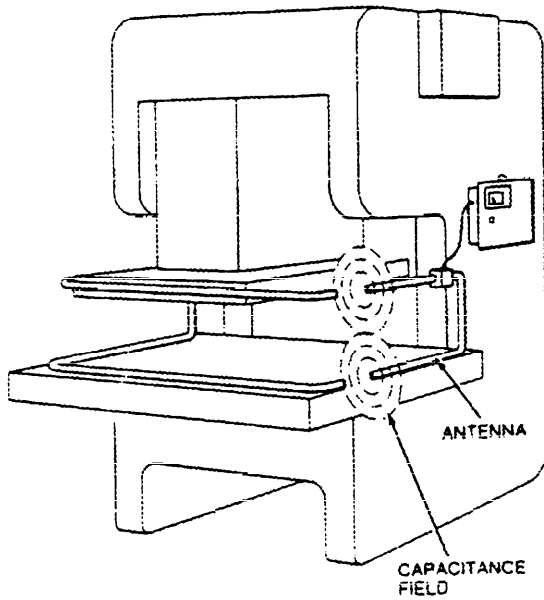

Figure 34.
Radiofrequency presence-
sensing device on a
power press

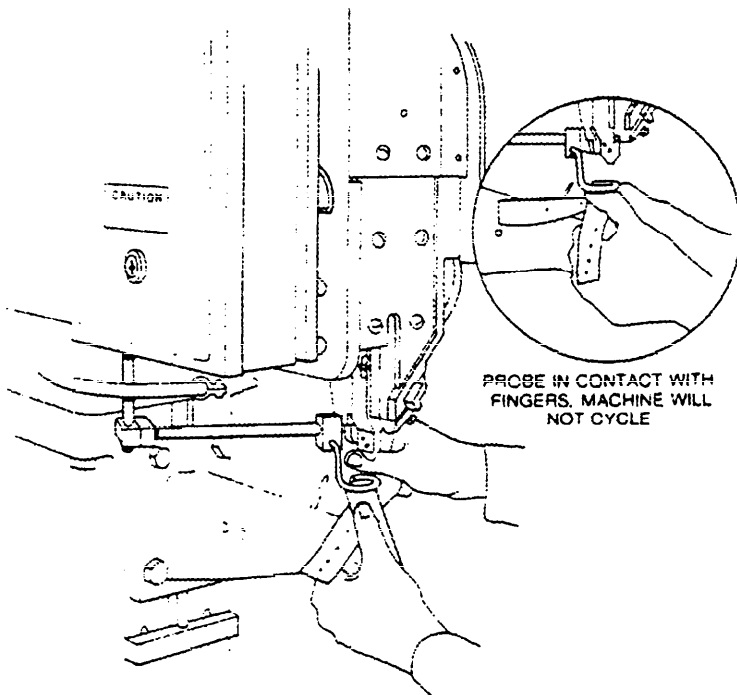
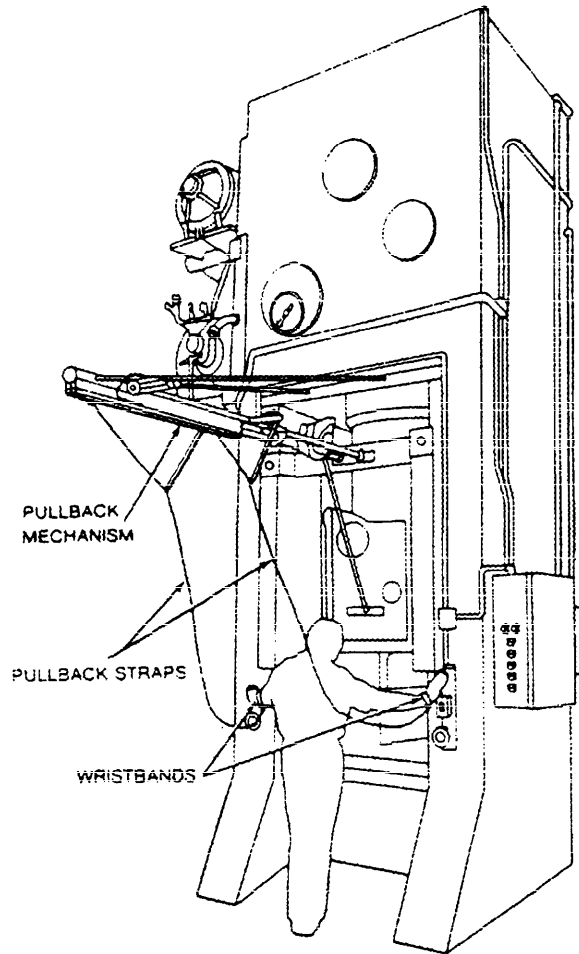

Figure 35.
Electromechanical
sensing device on an eyeletter



*Figure 36.
Pullback device on a
power press*

Pullback

Pullback devices utilize a series of cables attached to the operator's hands, wrists, and/or arms. This type of device is primarily used on machines with stroking action. When the slide/ram is up between cycles, the operator is allowed access to the point of operation. When the slide/ram begins to cycle by starting its descent, a mechanical linkage automatically assures withdrawal of the hands from the point of operation.

Figure 36 shows a pullback device on a straight-side power press. When the slide/ram is in the "up" position, the operator can feed material by hand into the point of operation. When the press cycle is actuated, the operator's hands and arms are automatically withdrawn. Figure 37 shows a pullback device on a smaller press.

A pullback device on a press brake is illustrated in Figure 38.

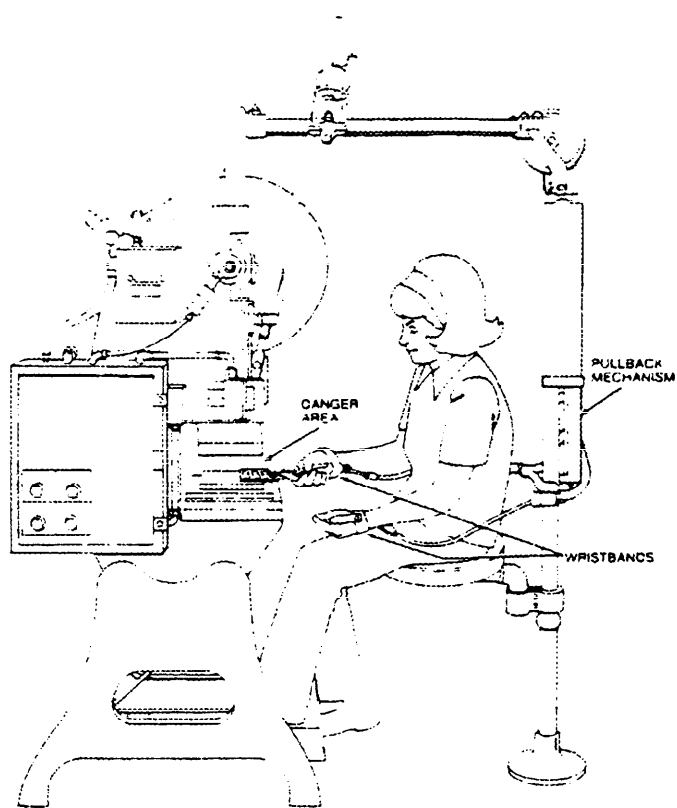

Figure 37.
Pullback device on a
power press

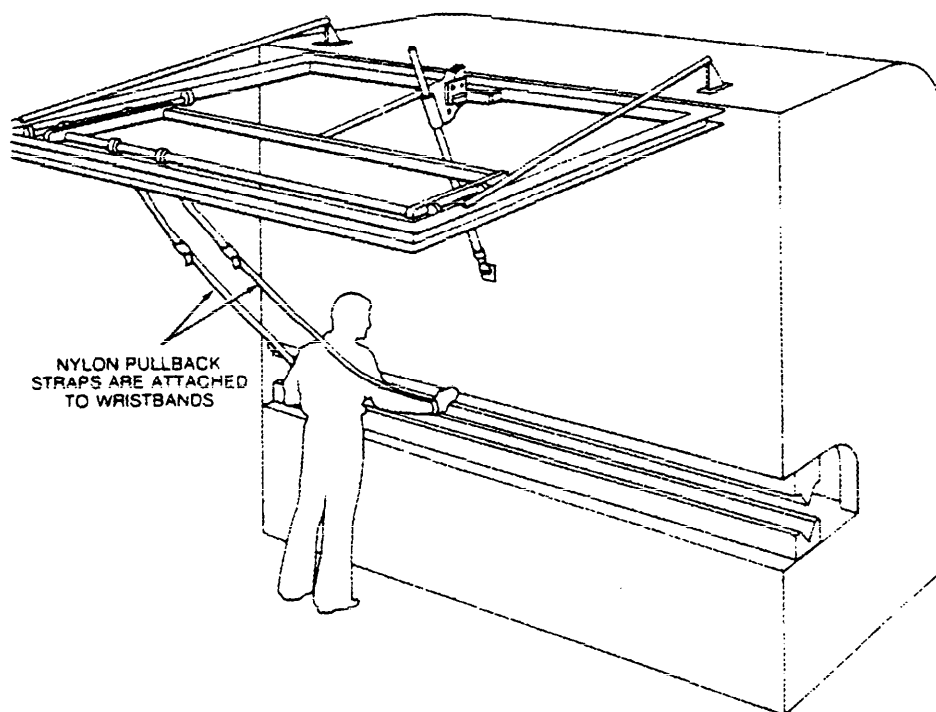

Figure 38.
Pullback device on press brake

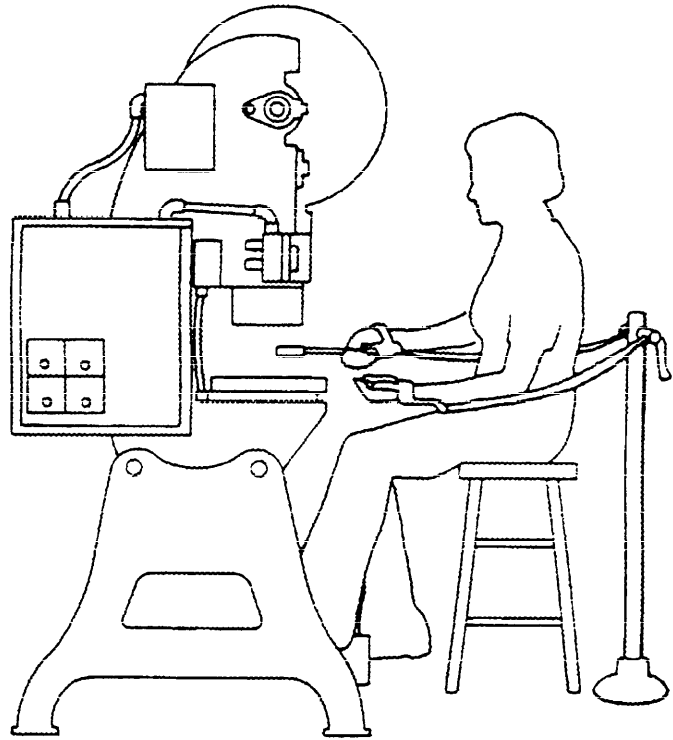
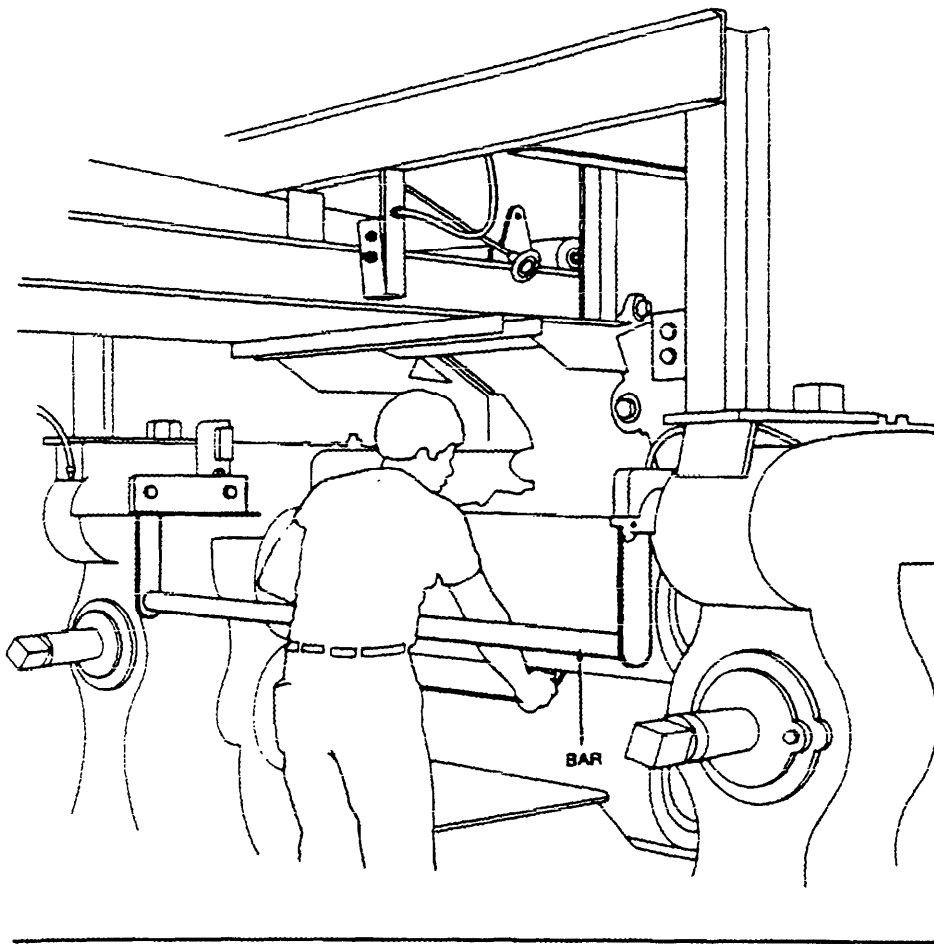

Figure 39.
Restraint device on power press

Restraint

The restraint (holdout) device in Figure 39 utilizes cables or straps that are attached to the operator's hands and a fixed point. The cables or straps must be adjusted to let the operator's hands travel within a predetermined safe area. There is no extending or retracting action involved. Consequently, hand-feeding tools are often necessary if the operation involves placing material into the danger area.



*Figure 40.
Pressure-sensitive body bar on
a rubber mill*

Safety Trip Controls

Safety trip controls provide a quick means for deactivating the machine in an emergency situation.

A pressure-sensitive body bar, when depressed, will deactivate the machine. If the operator or anyone trips, loses balance, or is drawn toward the machine, applying pressure to the bar will stop the operation. The positioning of the bar, therefore, is critical. It must stop the machine before a part of the employee's body reaches the danger area. Figure 40 shows a pressure-sensitive body bar located on the front of a rubber mill.

When pressed by hand, the safety deactivates the machine. Because the triprod has to be actuated by the operator during an emergency situation, its proper position is also critical. Figure 41 shows a triprod located above the rubber mill. Figure 42 shows another application of a triprod.

Safety tripwire cables are located around the perimeter of or near the danger area. The operator must be able to reach the cable with either hand to stop the machine. Figure 43 shows a calender equipped with this type of control, while Figure 44 shows a tomato sorter with a safety tripwire cable.

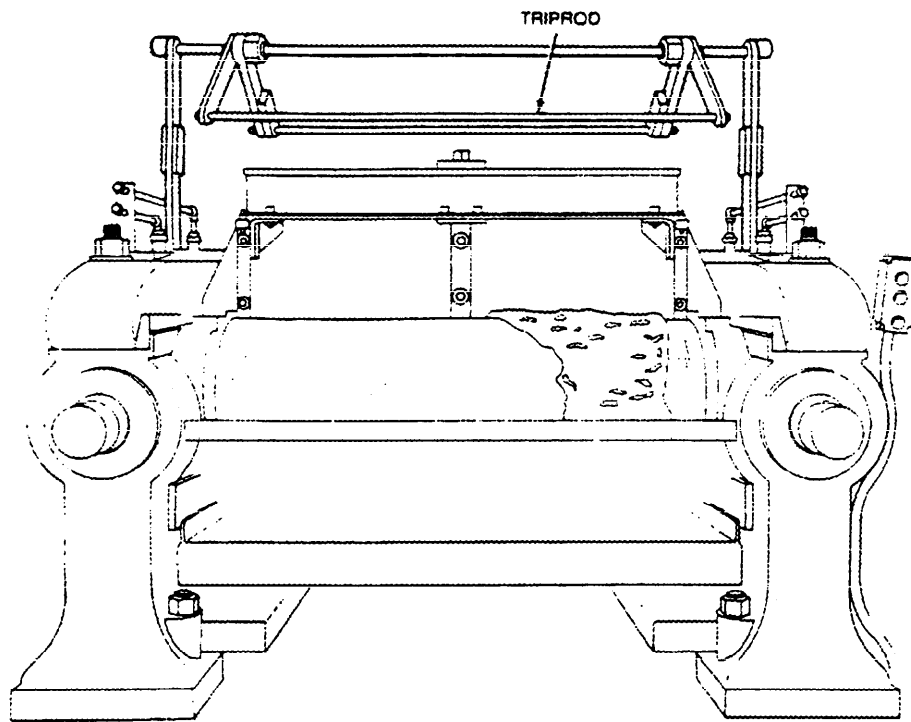

*Figure 41.
Safety triprod on a rubber mill*

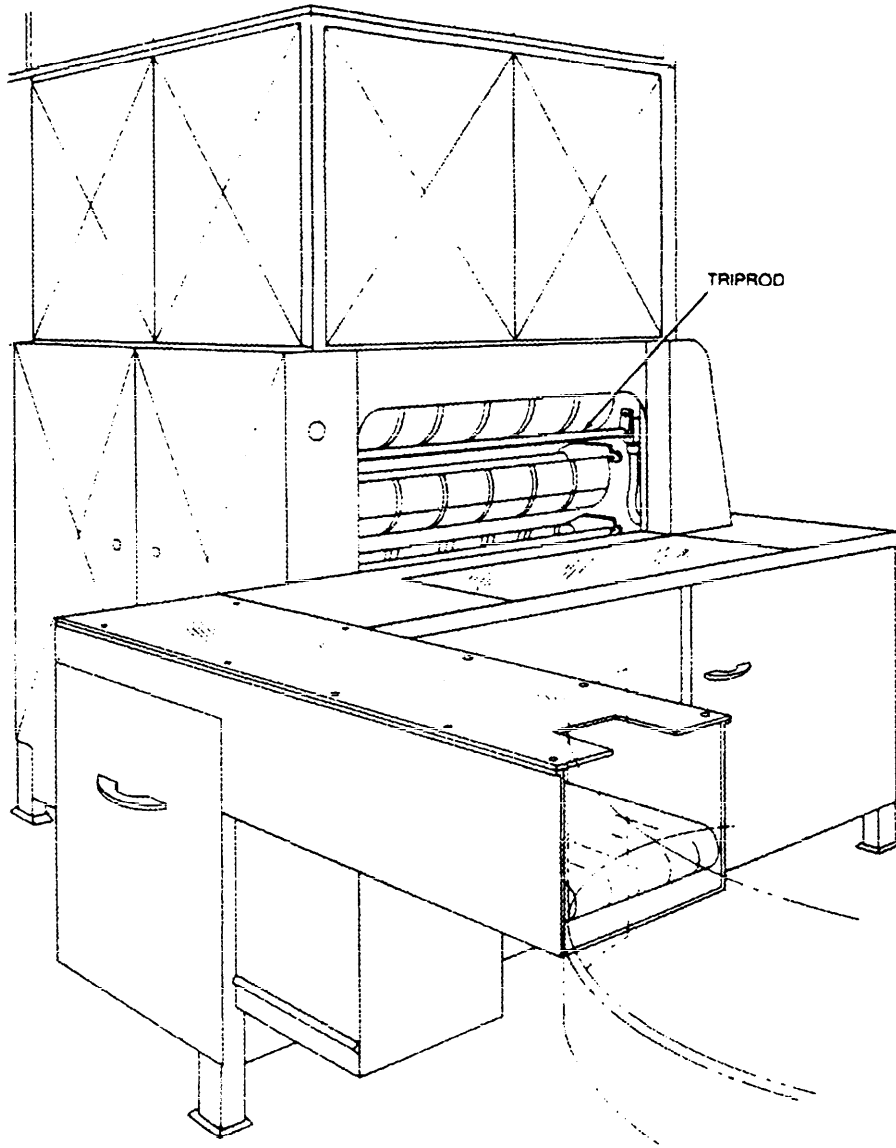

Figure 42.
Safety triprod on a bread
proofer machine

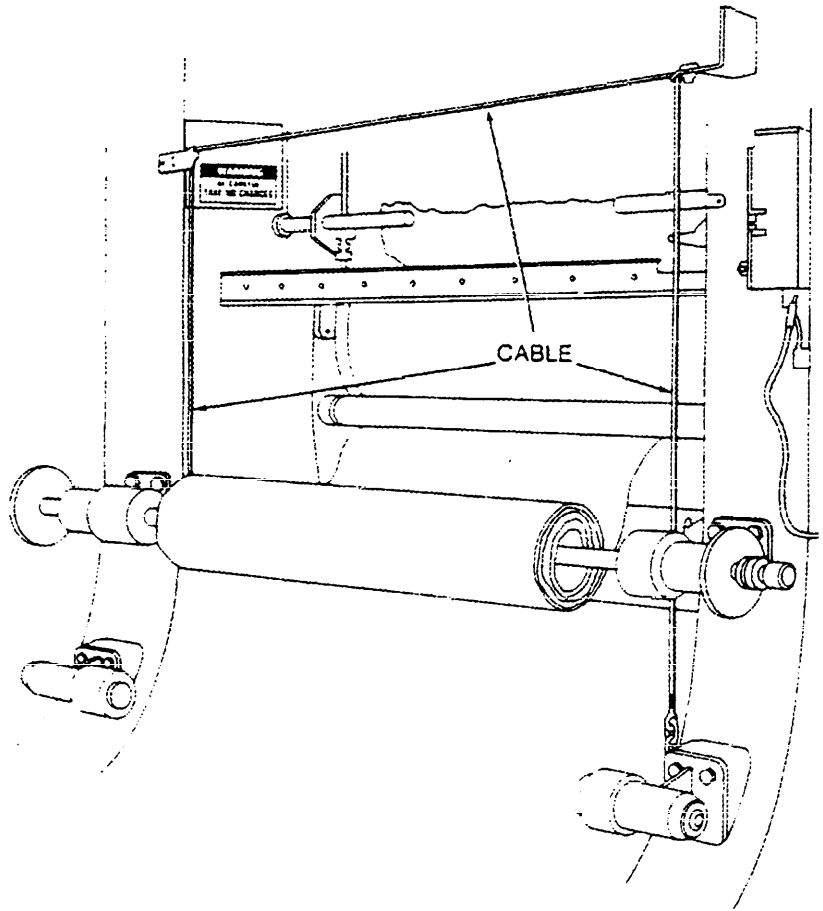
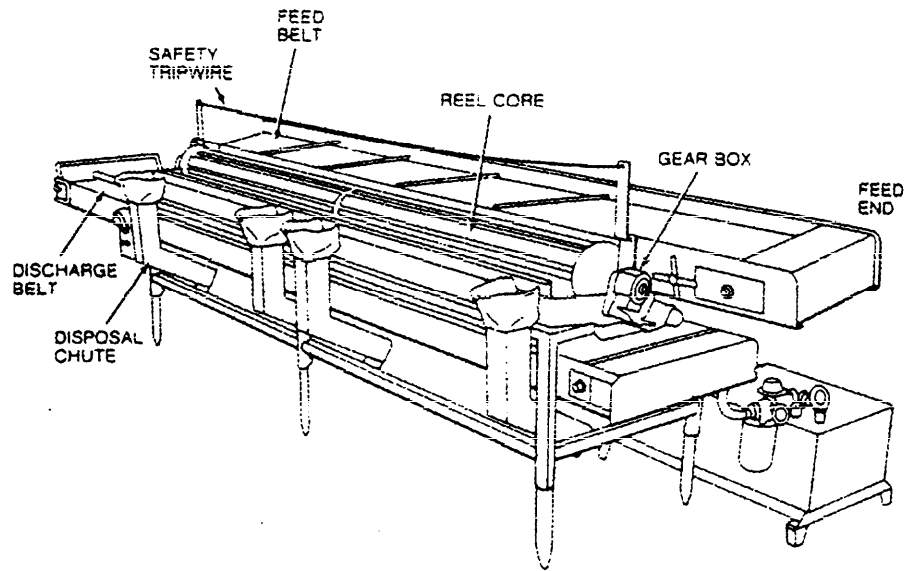

Figure 43.
Safety tripwire cable on
a calender

Figure 44.
Safety tripwire on a
tomato sorter



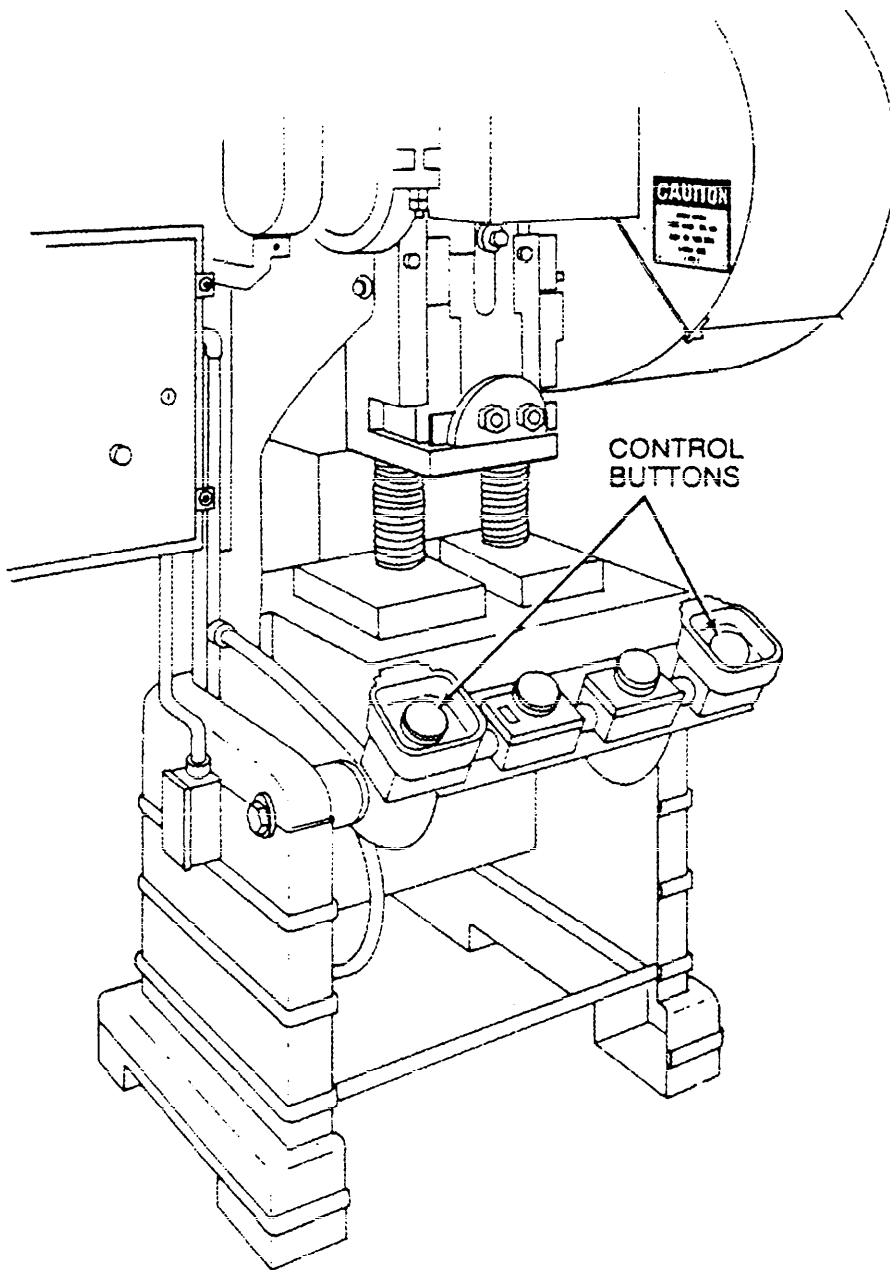

Figure 45.
Two-hand control buttons
on part-revolution clutch
power press

All of these tripwire rods or other safety devices must be manually reset to restart the machine. Simply releasing the tripwire to restart the machine will not ensure that the employee is out of danger when the machine restarts.

Two-Hand Control

The two-hand control requires constant, concurrent pressure by the operator to activate the machine. This kind of control requires a part-revolution clutch, brake, and a brake monitor if used on a power press as shown in Figure 45. With this type of device, the operator's hands are required to be at a safe location (on control buttons) and at a safe distance from the danger area while the machine completes its closing cycle.

Devices

Method	Safeguarding Action	Advantages	Limitations
Photoelectric	<p>Machine will not start cycling when the light field is interrupted</p> <p>When the light field is broken by any part of the operator's body during the cycling process, immediate machine braking is activated</p>	<p>Can allow freer movement for operator.</p> <p>Simplicity of use</p> <p>Used by multiple operators</p> <p>Provide passerby protection</p> <p>No adjustment required</p>	<p>Does not protect against mechanical failure</p> <p>Limited to machines that can be stopped</p>
Radiofrequency (optical)	<p>Machine cycling will not start when the capacitance field is interrupted</p> <p>When the capacitance field is disturbed by any part of the operator's body during the cycling process, immediate machine braking is activated</p>	<p>Can allow freer movement for operator</p>	<p>Does not protect against mechanical failure</p> <p>Antennae sensitivity must be properly adjusted; this adjustment must be maintained properly</p> <p>Limited to machines that can be stopped</p>
Electromechanical	<p>Contact bar or probe travels a predetermined distance between the operator and the danger area.</p> <p>Interruption of this movement prevents the starting of machine cycle.</p>	<p>Can allow access at the point of operation</p>	<p>Contact bar or probe must be properly adjusted for each application; this adjustment must be maintained properly</p>
<p>Pullback</p> <p>Restraint (holdback)</p>	<p>As the machine begins to cycle, the operator's hands are pulled out of the danger area</p> <p>Prevents the operator from reaching into the danger area</p>	<p>Eliminates the need for auxiliary barriers or other interference at the danger area</p> <p>Little risk of mechanical failure</p>	<p>Limits movement of operator</p> <p>May obstruct work space around operator</p> <p>Adjustments must be made for specific operations and for each individual</p> <p>Requires frequent inspections and regular maintenance</p> <p>Requires close supervision of the operator's use of the equipment</p> <p>Limits movement of operator</p> <p>May obstruct work space</p> <p>Adjustments must be made for specific operations and each individual</p> <p>Requires close supervision of the operator's use of the equipment</p>

in twice

Devices

Method	Safeguarding Action	Advantages	Limitations
Safety trip controls: Pressure-sensitive body bar Safety triprod Safety tripwire	Stops machine when tripped	Simplicity of use	All controls must be manually activated May be difficult to activate controls because of their location Only protects the operator May require special fixtures to hold work May require a machine brake
Two-hand control	Concurrent use of both hands is required, preventing the operator from entering the danger area	Operator's hands are at a pre-determined location Operator's hands are free to pick up a new part after first half of cycle is completed	Requires a partial cycle machine with a brake Some two-hand controls can be rendered unsafe by holding with arm or blocking, thereby permitting one-hand operation Protects only the operator
Two-hand trip	Concurrent use of two hands on separate controls prevents hands from being in danger area when machine cycle starts	Operator's hands are away from danger area Can be adapted to multiple operations No obstruction to hand feeding Does not require adjustment for each operation	Operator may try to reach into danger area after tripping machine Some trips can be rendered unsafe by holding with arm or blocking, thereby permitting one-hand operation Protects only the operator May require special fixtures
Gate	Provides a barrier between danger area and operator or other personnel	Can prevent reaching into or walking into the danger area	May require frequent inspection and regular maintenance May interfere with operator's ability to see the work

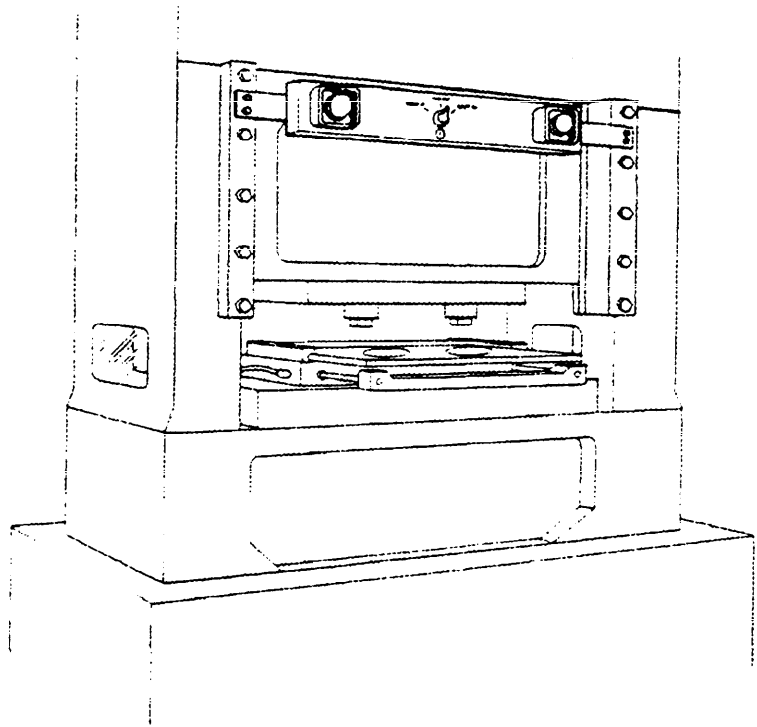
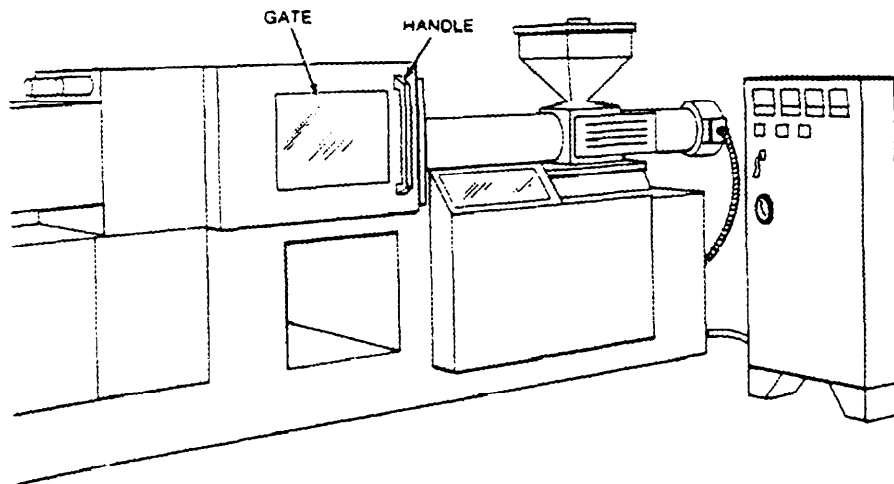

*Figure 46.
Two-hand control buttons
on full-revolution clutch
power press*

Two-Hand Trip

The two-hand trip in Figure 46 requires concurrent application of both the operator's control buttons to activate the machine cycle, after which the hands are free. This device is usually used with machines equipped with full-revolution clutches. The trips must be placed far enough from the point of operation to make it impossible for the operator to move his or her hands from the trip buttons or handles into the point of operation before the first half of the cycle is completed. The distance from the trip button depends upon the speed of the cycle and the band speed constant. Thus the operator's hands are kept far enough away to prevent them from being placed in the danger area prior to the slide/ram or blade reaching the full "down" position.

To be effective, both two-hand controls and trips must be located so that the operator cannot use two hands or one hand and another part of his/her body to trip the machine.



*Figure 47.
Horizontal injection molding
machine with gate*

Gate

A gate is a moveable barrier that protects the operator at the point of operation before the machine cycle can be started. Gates are, in many instances, designed to be operated with each machine cycle.

Figure 47 shows a horizontal injection molding machine with a gate. To be effective, the gate must be interlocked so that the machine will not begin a cycle unless the gate guard is in place. It must be in the closed position before the machine can function.

Figure 48 shows a gate on a power press. If the gate is not permitted to descend to the fully closed position, the press will not function.

Another potential application of this type of guard is where the gate is a component of a perimeter safeguarding system. Here the gate may provide protection not only to the operator but to pedestrian traffic as well.

Safeguarding by Location/Distance

The examples mentioned below are a few of the numerous applications of the principle of safeguarding by location/distance. A thorough hazard analysis of each machine and particular situation is absolutely essential before attempting this safeguarding technique.

To consider a part of a machine to be safeguarded by location, the dangerous moving part of a machine must be so positioned that those areas are not accessible or do not present a hazard to a worker during the normal

operation of the machine. This may be accomplished by locating a machine so that the hazardous parts of the machine are located away from operator work stations or other areas where employees walk or work. This can be accomplished by positioning a machine with its power transmission apparatus against a wall and leaving all routine operations conducted on the other side of the machine. Additionally, enclosure walls or fences can restrict access to machines. Another possible solution is to have dangerous parts located high enough to be out of the normal reach of any worker.

The feeding process can be safeguarded by location if a safe distance can be maintained to protect the worker's hands. The dimensions of the stock being worked on may provide adequate safety.

For instance, if the stock is several feet long and only one end of the stock is being worked on, the operator may be able to hold the opposite end while the work is being performed. An example would be a single-end punching machine. However, depending upon the machine, protection might still be required for other personnel.

The positioning of the operator's control station provides another potential approach to safeguarding by location. Operator controls may be located at a safe distance from the machine if there is no reason for the operator to tend it.

Feeding and Ejection Methods to Improve Operator Safety

Many feeding and ejection methods do not require the operator to place his or her hands in the danger area. In some cases, no operator involvement is necessary after the machine is set up. In other situations, operators can manually feed the stock with the assistance of a feeding mechanism. Properly designed ejection methods do not require any operator involvement after the machine starts to function.

Some feeding and ejection methods may even create hazards themselves. For instance, a robot may eliminate the need for an operator to be near the machine but may create a new hazard itself by the movement of its arm.

Using these feeding and ejection methods does not eliminate the need for guards and devices. Guards and devices must be used wherever they are necessary and possible in order to provide protection from exposure to hazards.

Types of feeding and ejection methods...

Automatic feeds reduce the exposure of the operator during the work process, and sometimes do not require any effort by the operator after the machine is set up and running.

In Figure 49, the power press has an automatic feeding mechanism. Notice the transparent fixed enclosure guard at the danger area.

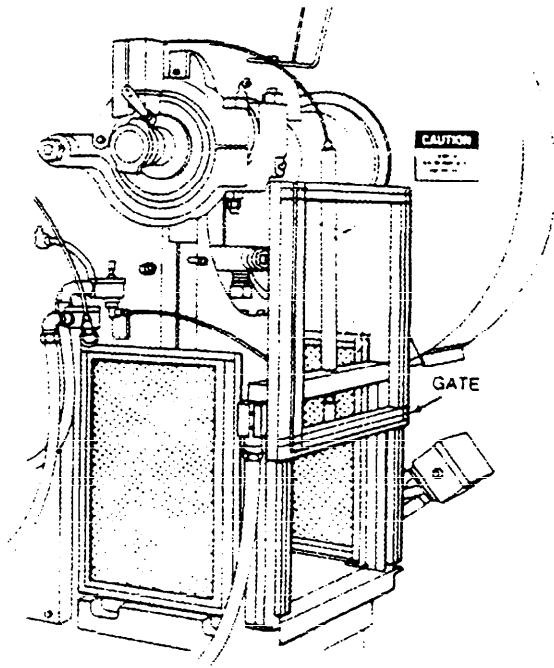

Figure 48.
Power press with gate

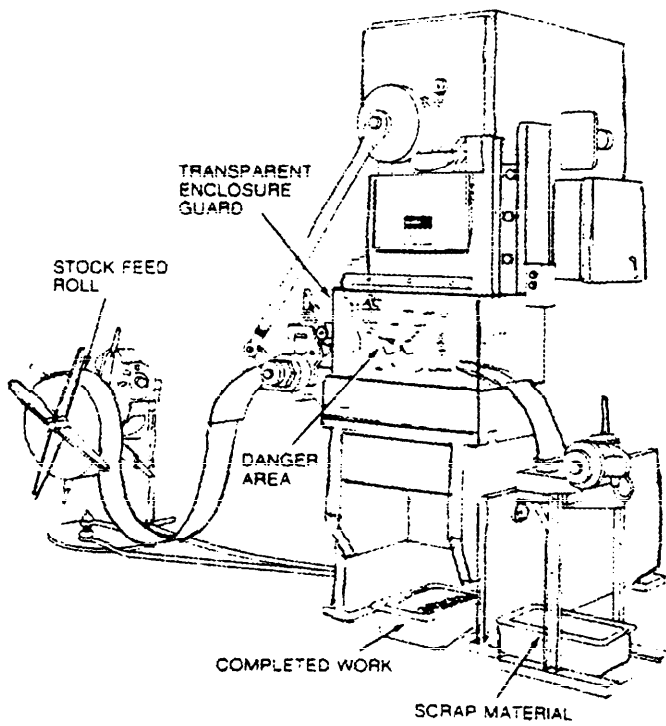
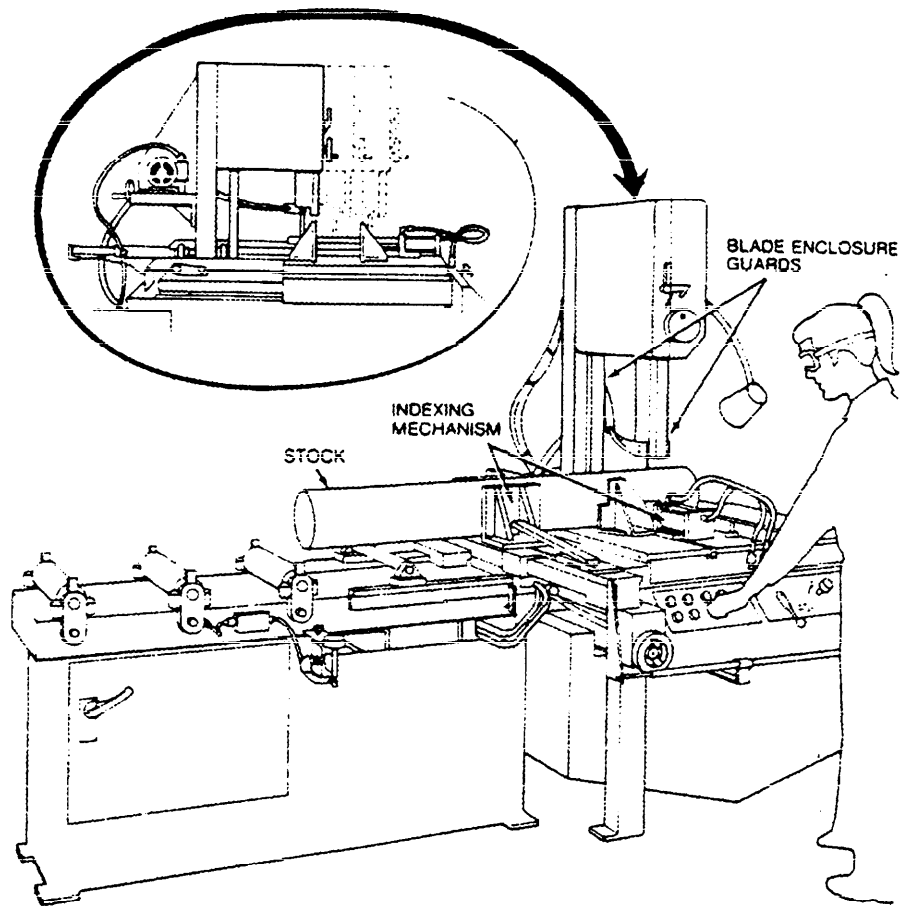

Figure 49.
Power press with
automatic feed



*Figure 50.
Saw with automatic
indexing mechanism and
traveling head*

Figure 50 shows a saw with an automatic indexing mechanism that moves the stock a predetermined distance for each cut. The traveling head automatically recycles for each cut.

With semiautomatic feeding, as in the case of a power press, the operator uses a mechanism to place the piece being processed under the ram at each stroke. The operator does not need to reach into the danger area, and the danger area is completely enclosed.

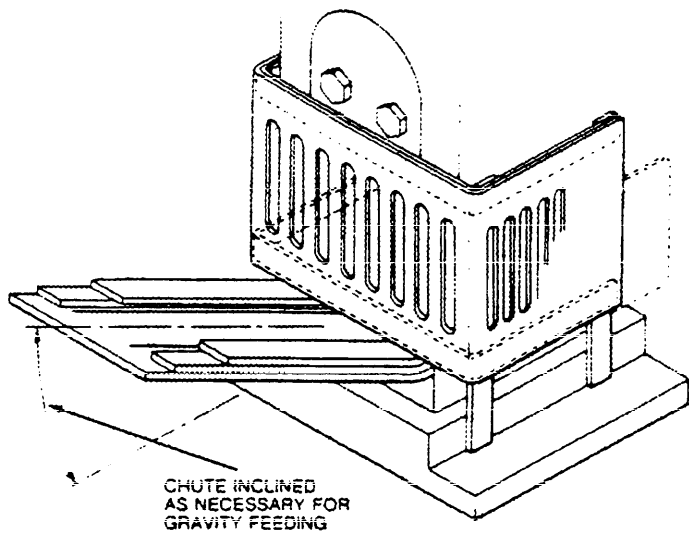
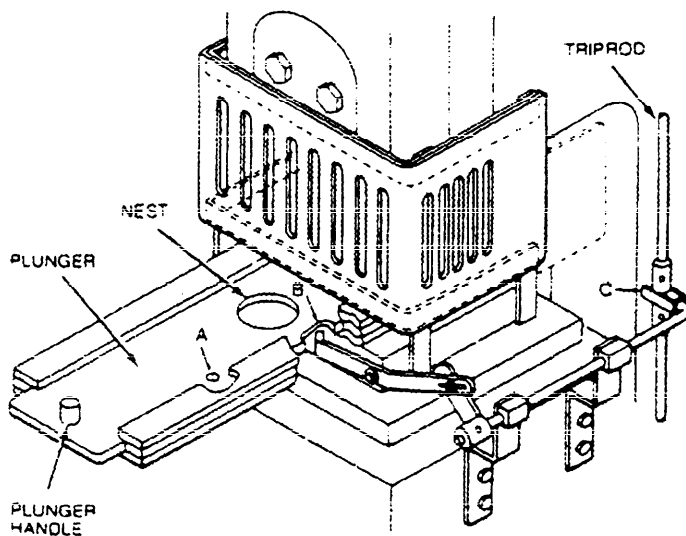

Figure 51.
Power press with chute feed

Figure 51 shows a chute feed. It may be either a horizontal or an inclined chute into which each piece is placed by hand. Using a chute feed on an inclined press not only helps center the piece as it slides into the die, but may also simplify the problem of ejection.

A plunger feed is shown in Figure 52. The blanks or pieces are placed in the nest one at a time by the plunger which pushes them under the slide. Plunger feeds are useful for operations on irregularly shaped workpieces which will not stack in a magazine or will not slide easily down a gravity chute. The mechanism shown is mechanically connected to the press tripping mechanism. When the plunger is pushed in, pin "B" is allowed to rise up into hole "A," allowing yoke "C" to release so the press can be tripped.

Figure 52.
Power press with plunger feed



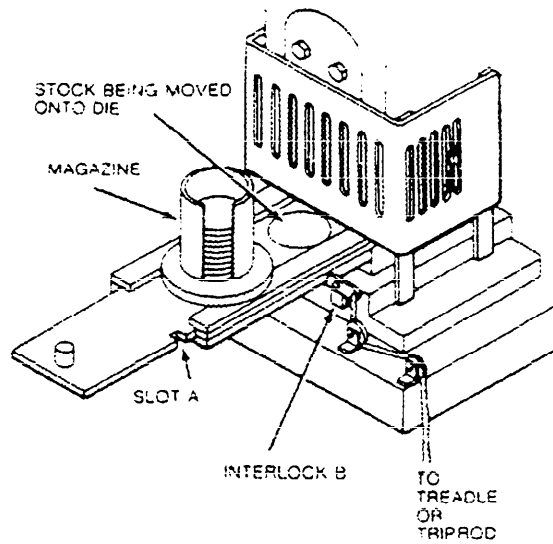
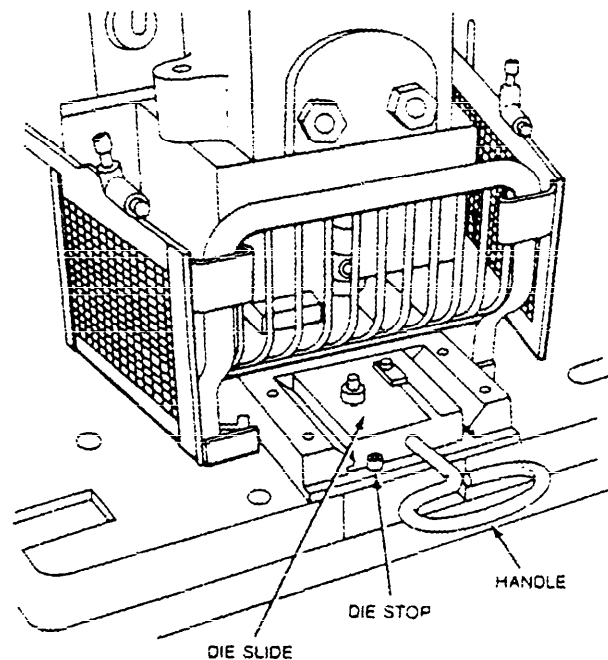

*Figure 53.
Power press with plunger
and magazine feed*

Figure 53 shows a plunger and magazine feed. Slot "A" must be in alignment with interlock "B" before the press can be tripped.

The sliding die in Figure 54 is pulled toward the operator for safe feeding and then pushed into position under the slide prior to the downward stroke. The die moves in and out by hand or by a foot lever. The die should be interlocked with the press to prevent tripping when the die is out of alignment with the slide. Providing "stops" will prevent the die from being inadvertently pulled out of the slides.

*Figure 54.
Power press with
sliding die*



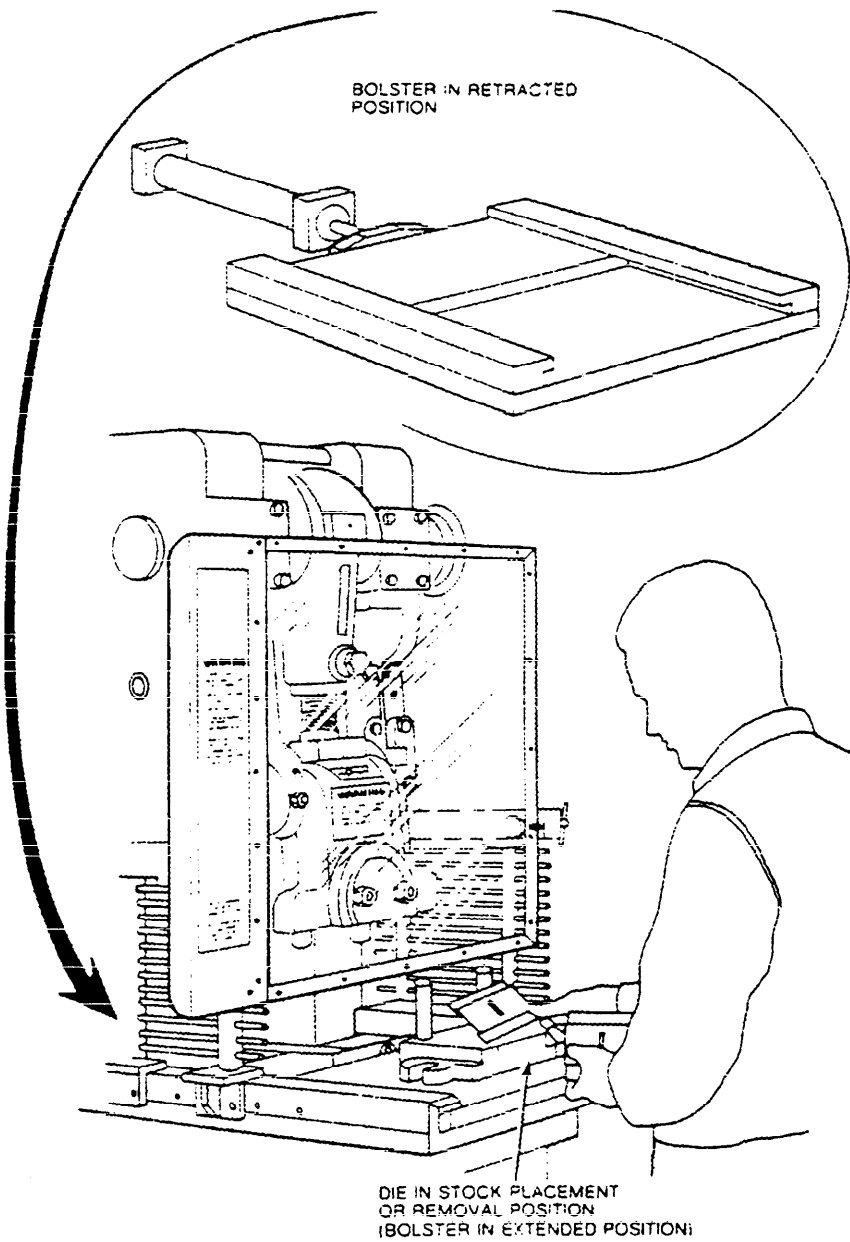

Figure 55.
Power press with sliding bolster

Figure 55 shows a sliding bolster. The press bed is modified with a hydraulically or pneumatically controlled bolster that slides in when "start" buttons are depressed, and out when the stroke is completed.

Figure 56 shows a double-dial feed. The dials revolve with each stroke of the press. The operator places the part to be processed in a nest on the dial which is positioned in front of the die. The dial is indexed with each upstroke of the press to deliver the nested part into the die.

Automatic ejection may employ either an air-pressure or a mechanical apparatus to remove the completed part from a press. It may be interlocked with the operating controls to prevent operation until part ejection is completed. This method requires additional safeguards for full protection of the operator.

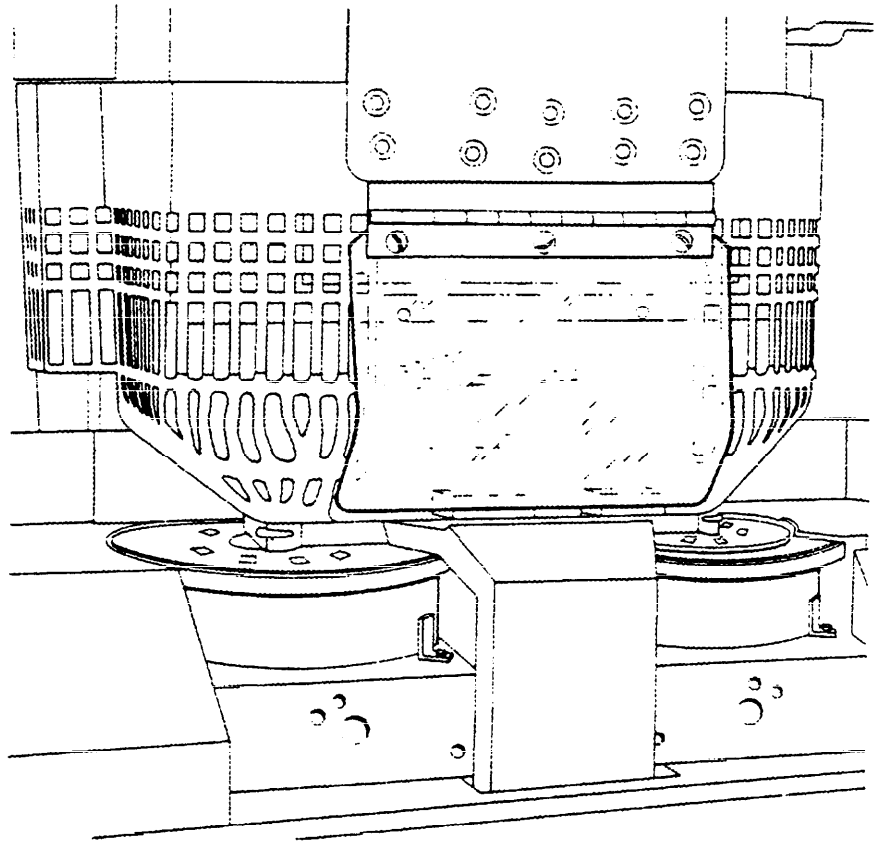
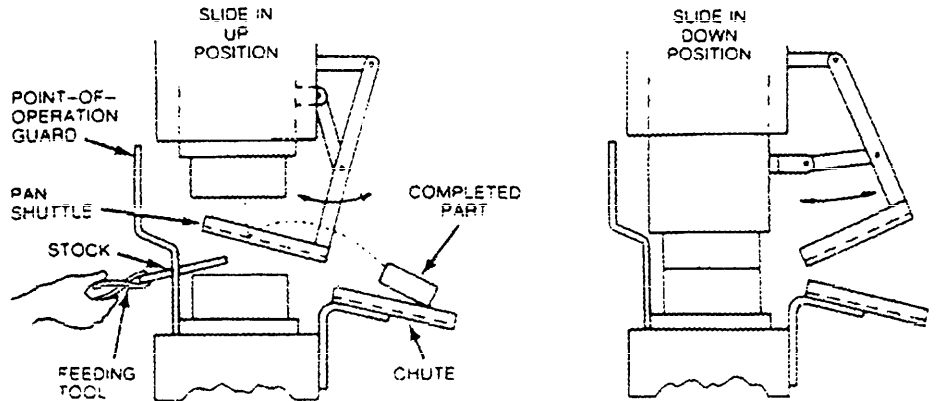
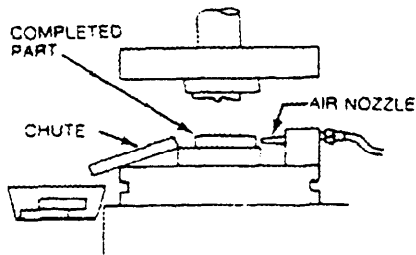

Figure 56.
Power press with
double-dial feed

As shown in Figure 57, the pan shuttle mechanism moves under the finished part as the slide moves toward the "up" position. The shuttle then catches the part stripped from the slide by the knockout pins and deflects it into a chute. When the ram moves down toward the next blank, the pan shuttle moves away from the die area.

Figure 57.
Shuttle ejection mechanism





*Figure 58.
Air ejection*

Figures 58 and 59 show air ejection and mechanical ejection mechanisms, respectively. Note: Air ejection methods often present a noise hazard to operators.

Figure 60 shows a semiautomatic ejection mechanism used on a power press. When the plunger is withdrawn from the die area, the ejector leg, which is mechanically coupled to the plunger, kicks the completed work out.

Essentially, robots perform work that would otherwise have to be done by an operator. They are best used in high-production processes requiring repeated routines where they prevent other hazards to employees. However, they may create hazards themselves, and if they do, appropriate guards must be used.

Figures 61, 62, and 63, respectively, show a type of robot in operation, the danger areas it can create, and an example of the kind of task (feeding a press) it can perform.

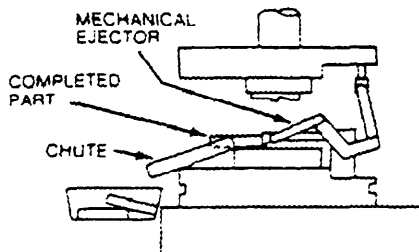

*Figure 59.
Mechanical ejection*

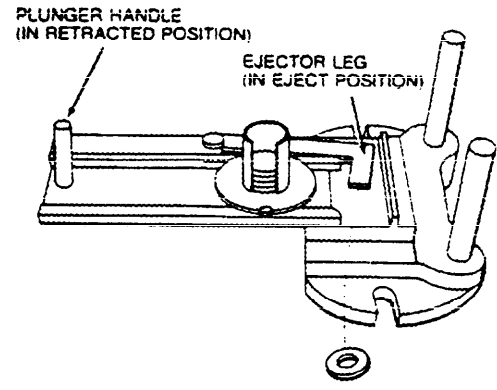
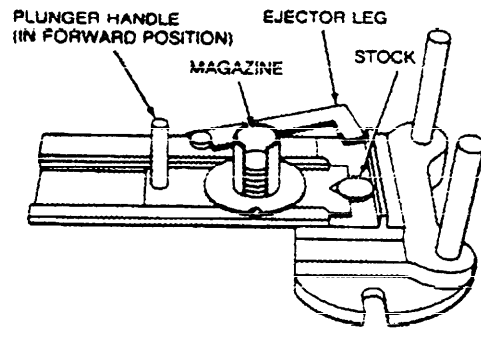
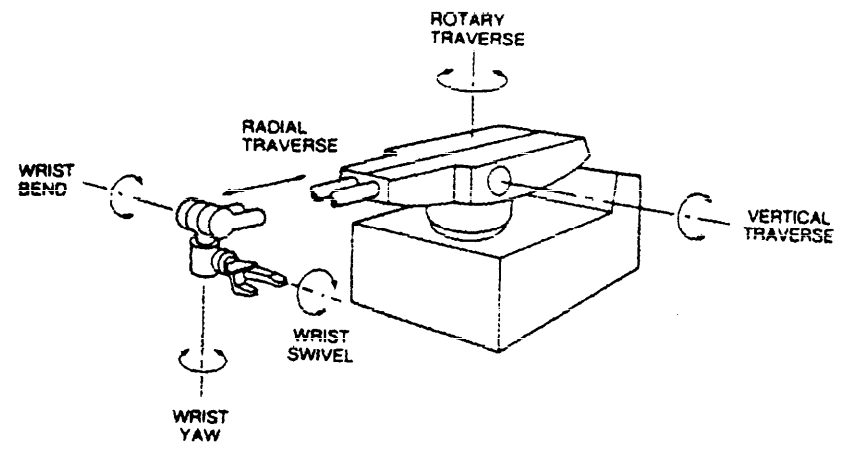

Figure 60.
Semiautomatic ejection mechanism

Figure 61.
Robot movement capability



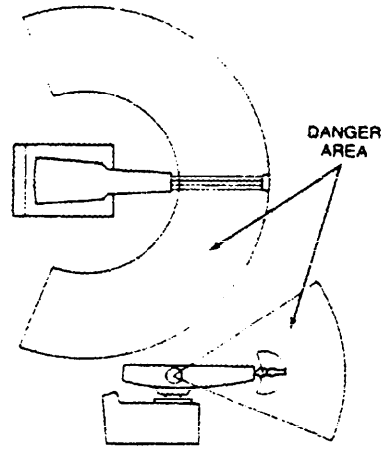

Figure 62.
Potential danger areas in
robot envelope

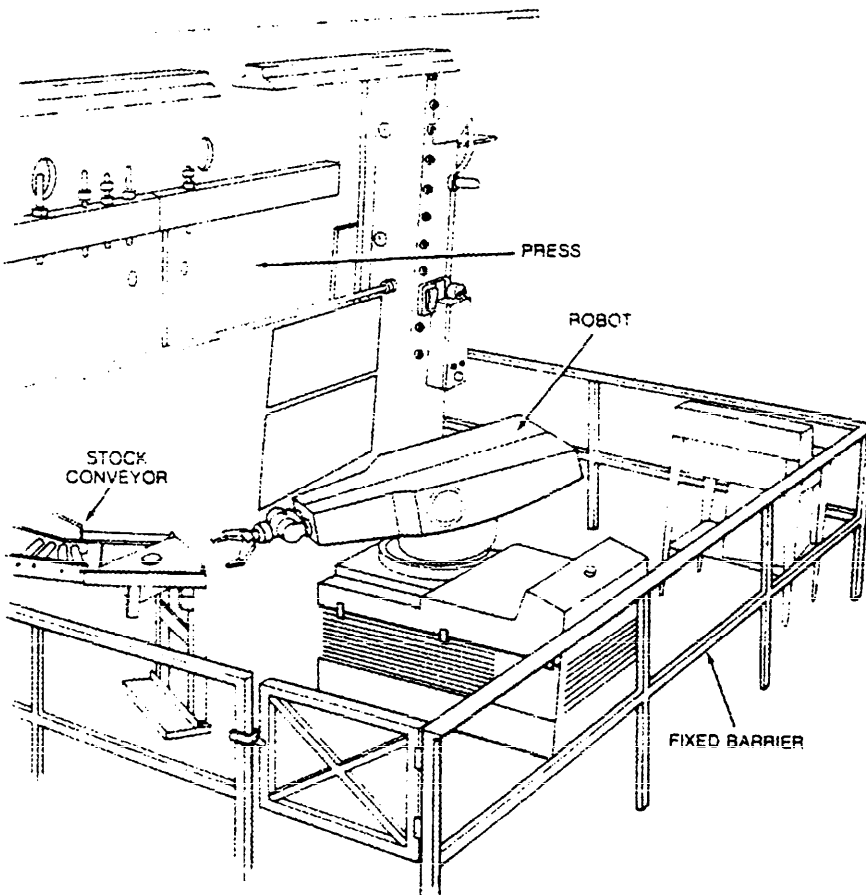

Figure 63.
Using barrier guards to protect
robot envelope

Feeding and Ejection Methods

Method	Safeguarding Action	Advantages	Limitations
Automatic Feed	Stock is fed from rolls, indexed by machine mechanism, etc.	Eliminates the need for operator involvement in the danger area	Other guards are also required for operator protection — usually fixed barrier guards Requires frequent maintenance May not be adaptable to stock variation
Semiautomatic Feed	Stock is fed by chutes, movable dies, dial feed, plungers, or sliding bolster		
Automatic Ejection	Work pieces are ejected by air or mechanical means		May create a hazard of blowing chips or debris Size of stock limits the use of this method Air ejection may present a noise hazard
Semiautomatic Ejection	Work pieces are ejected by mechanical means which are initiated by the operator	Operator does not have to enter danger area to remove finished work	Other guards are required operator protection May not be adaptable to stock variation
Robots	They perform work usually done by operator	Operator does not have to enter danger area Are suitable for operations where high stress factors are present, such as heat and noise	Can create hazards themselves Require maximum maintenance Are suitable only to specific operations

Miscellaneous Aids

While these aids do not give complete protection from machine hazards, they may provide the operator with an extra margin of safety. Sound judgment is needed in their application and usage. Below are several examples of possible applications.

An awareness barrier does not provide physical protection, but serves only to remind a person that he or she is approaching the danger area. Generally, awareness barriers are not considered adequate when continual exposure to the hazard exists.

Figure 64 shows a rope used as an awareness barrier on the rear of a power squaring shear. Although the barrier does not physically prevent a person from entering the danger area, it calls attention to it. For an employee to enter the danger area, an overt act must take place, that is, the employee must either reach or step over, under or through the barrier.

Figure 65 shows an awareness barrier on a stitching machine.

Shields, another aid, may be used to provide protection from flying particles, splashing cutting oils, or coolants. Figure 66 shows several potential applications.

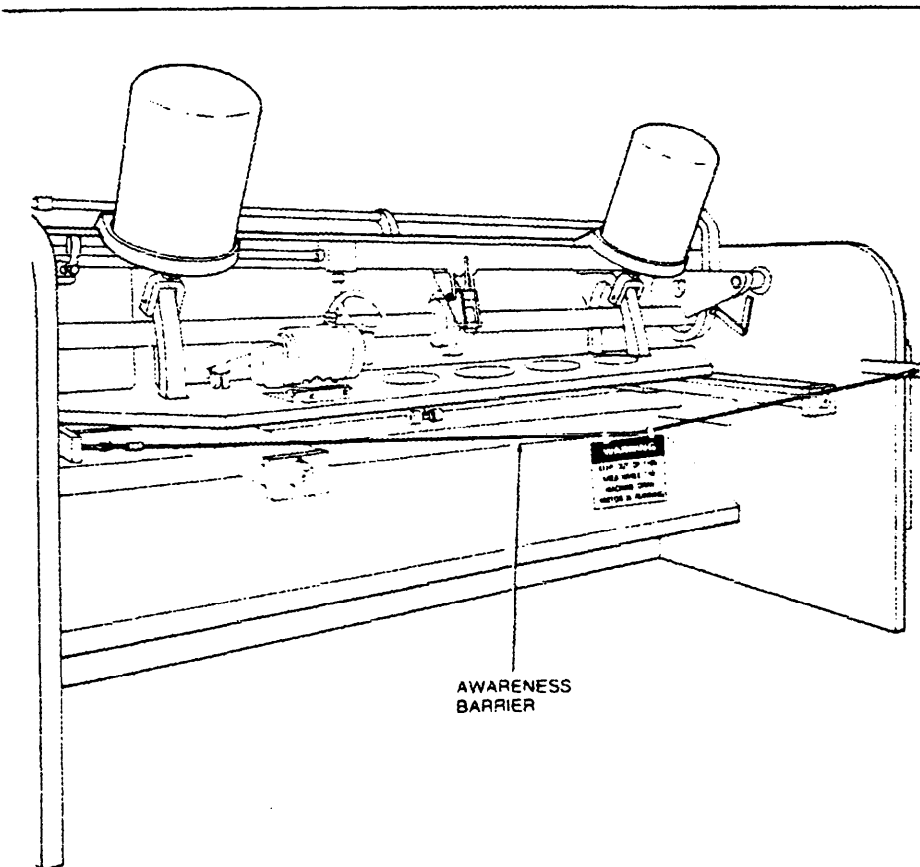

Figure 64.
Rear view of power
shearing square

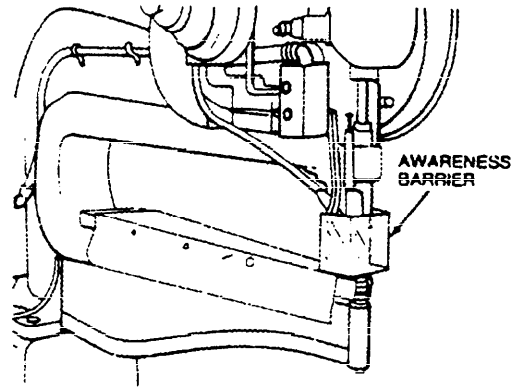
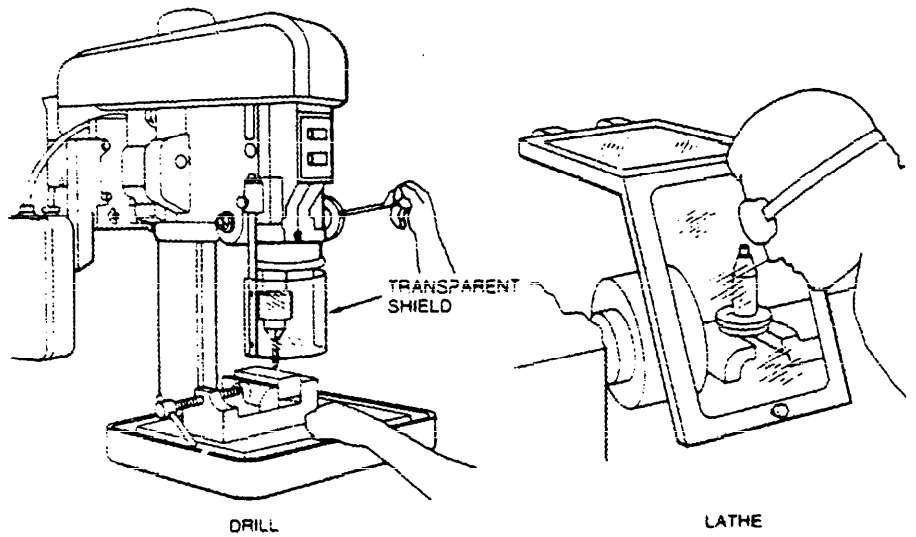

Figure 65.
Awareness barrier on
stitching machine

Figure 66.
Other applications of shields



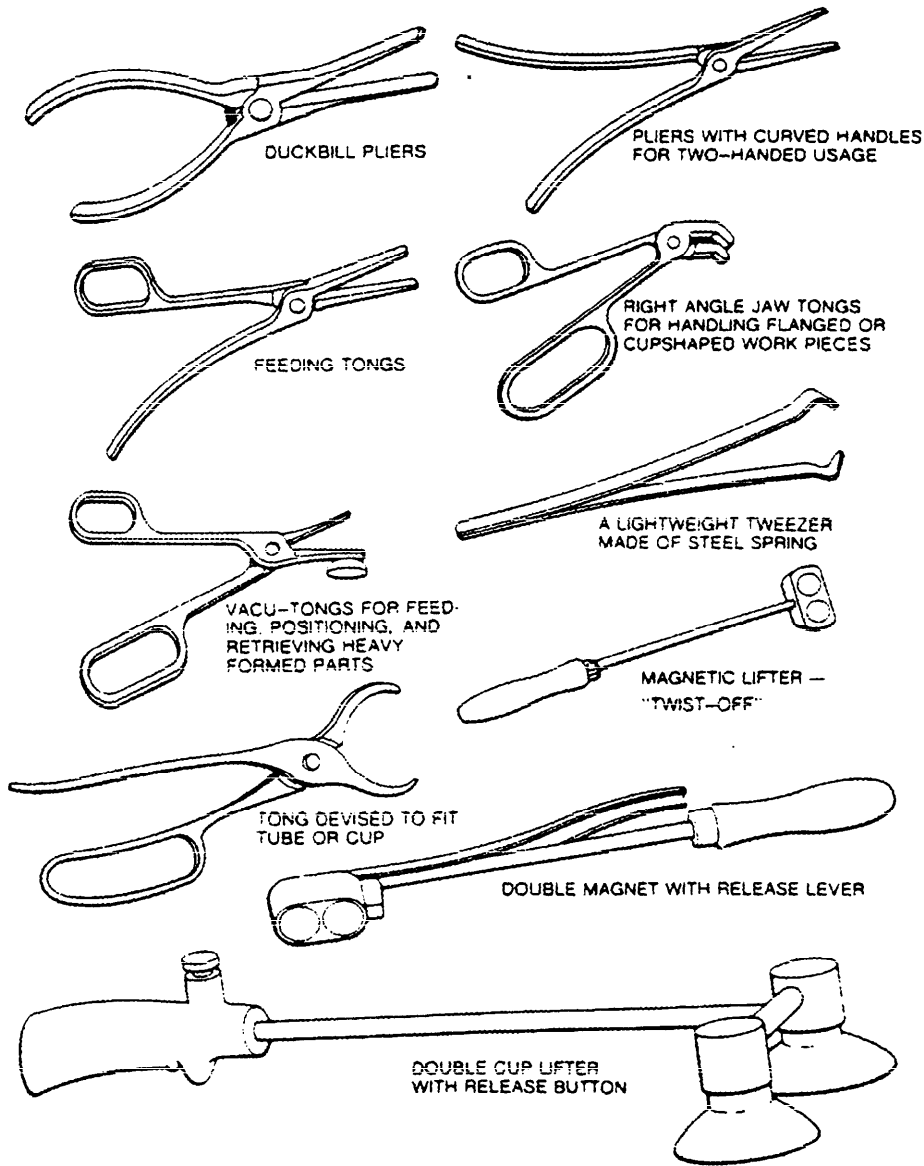
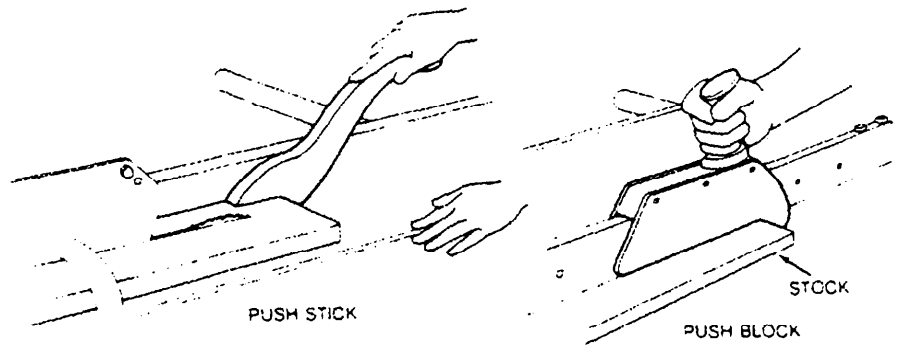

Figure 67.
Holding tools

Special hand tools may be used to place or remove stock, particularly from or into the point of operation of a machine. A typical use would be for reaching into the danger area of a press or press brake. Figure 67 shows an assortment of tools for this purpose. Holding tools should not be used instead of other machine safeguards; they are merely a supplement to the protection that other guards provide.

A push stick or block, such as those in Figure 68, may be used when feeding stock into a saw blade. When it becomes necessary for hands to be in close proximity to the blade, the push stick or block may provide a few inches of safety and prevent a severe injury. In the illustration the push block fits over the fence.

Figure 68.
Use of push stick or push block



Guard Construction

Today many builders of single-purpose machines provide point-of-operation and power transmission safeguards as standard equipment. However, not all machines in use have built-in safeguards provided by the manufacturer.

Guards designed and installed by the builder offer two main advantages:

- They usually conform to the design and function of the machine.
- They can be designed to strengthen the machine in some way or to serve some additional functional purposes.

User-built guards are sometimes necessary for a variety of reasons. They have these advantages:

- Often, with older machinery, they are the only practical safeguarding solution.
- They may be the only choice for mechanical power transmission apparatus in older plants, where machinery is not powered by individual motor drives.
- They permit options for point-of-operation safeguards when skilled personnel design and make them.
- They can be designed and built to fit unique and even changing situations.
- They can be installed on individual dies and feeding mechanisms.
- Design and installation of machine safeguards by plant personnel can help to promote safety consciousness in the workplace.

However, they also have disadvantages:

- User-built guards may not conform well to the configuration and function of the machine.
- There is a risk that user-built guards may be poorly designed or built.

Point-of-Operation Guards

Point-of-operation safeguarding is complicated by the number and complexity of machines and also by the different uses for individual machines. For these reasons, not all machine builders provide point-of-operation guards on their products. In many cases a point-of-operation guard can only be made and installed by the user after a thorough hazard analysis of the work requirements. Poorly designed, built or installed guards may create a hazard rather than eliminate one. To be effective they must safeguard the employee while allowing the work to continue with minimum disruption to the production process.

Mechanical Power Transmission Apparatus Guarding

A significant difference between power transmission guards and point-of-operation guards is that the former type needs no opening for feeding stock. The only openings necessary for power transmission guards are those for lubrication, adjustment, repair, and inspection. These openings should be provided with interlocked covers that cannot be removed except by using tools for service or adjustment.

To be effective, power transmission guards should cover all moving parts in such a manner that no part of the operator's body can come in contact with them.

Guard Material

Under many circumstances, metal is the best material for guards. Guard framework is usually made from structural shapes, pipe, bar, or rod stock. Filler material generally is expanded or perforated or solid sheet metal or wire mesh. It may be feasible to use plastic or safety glass where visibility is required.

Guards made of wood generally are not recommended because of their flammability and lack of durability and strength. However, in areas where corrosive materials are present, wooden guards may be the better choice.

Machinery Maintenance and Repair

Good maintenance and repair procedures contribute significantly to the safety of the maintenance crew as well as that of machine operators. The variety and complexity of machines to be serviced, the hazards associated with their power sources, the special dangers that may be present during machine breakdown, and the severe time constraints often placed on maintenance personnel all make safe maintenance and repair work difficult.

Training and aptitude of people assigned to these jobs should make them alert for the intermittent electrical failure, the worn part, the inappropriate noise, the cracks or other signs that warn of impending breakage or that a safeguard has been damaged, altered, or removed. By observing machine operators at their tasks and listening to their comments, maintenance personnel may learn where potential trouble spots are and give them early attention before they develop into sources of accidents and injury. Sometimes all that is needed to keep things running smoothly and safely is machine lubrication or adjustment. Any damage observed or suspected should be reported to the supervisor; if the condition impairs safe operation, the machine should be taken out of service for repair. Safeguards that are missing, altered, or damaged also should be reported so appropriate action can be taken to insure against worker injury.

If possible, machine design should permit routine lubrication and adjustment without removal of safeguards. But when safeguards must be removed, and the machine serviced, the lockout procedure of 29 CFR 1910.147 must be adhered to. The maintenance and repair crew must never fail to replace the guards before the job is considered finished and the machine released from lockout.

Is it necessary to oil machine parts while a machine is running? If so, special safeguarding equipment may be needed solely to protect the oiler from exposure to hazardous moving parts. Maintenance personnel must know which machines can be serviced while running and which cannot. "If in doubt, lock it out." Obviously, the danger of accident or injury is reduced by shutting off and locking out all sources of energy.

In situations where the maintenance or repair worker would necessarily be exposed to electrical elements or hazardous moving machine parts in the performance of the job, there is no question that all power sources must be shut off and locked out before work begins. Warning signs or tags are inadequate insurance against the untimely energizing of mechanical equipment.

Thus, one of the first procedures for the maintenance person is to disconnect and lock out the machine from all of its power sources, whether the source is electrical, mechanical, pneumatic, hydraulic, or a combination of these. Energy accumulation devices must be "bied down."

Electrical: Unexpected energizing of any electrical equipment that can be started by automatic or manual remote control may cause electric shock or

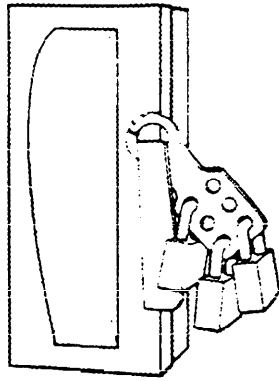

Figure 69.
Lockout hasp

other serious injuries to the machine operator, the maintenance worker, or others operating adjacent machines controlled by the same circuit. For this reason, when maintenance personnel must repair electrically powered equipment, they should open the circuit at the switch box and padlock the switch (lock it out) in the "off" position. This switch should be tagged with a description of the work being done, the name of the maintenance person, and the department involved. When more than one worker is to be engaged in the servicing/maintenance function a typical lockout hasp to which each may affix a personal lock is shown in Figure 69.

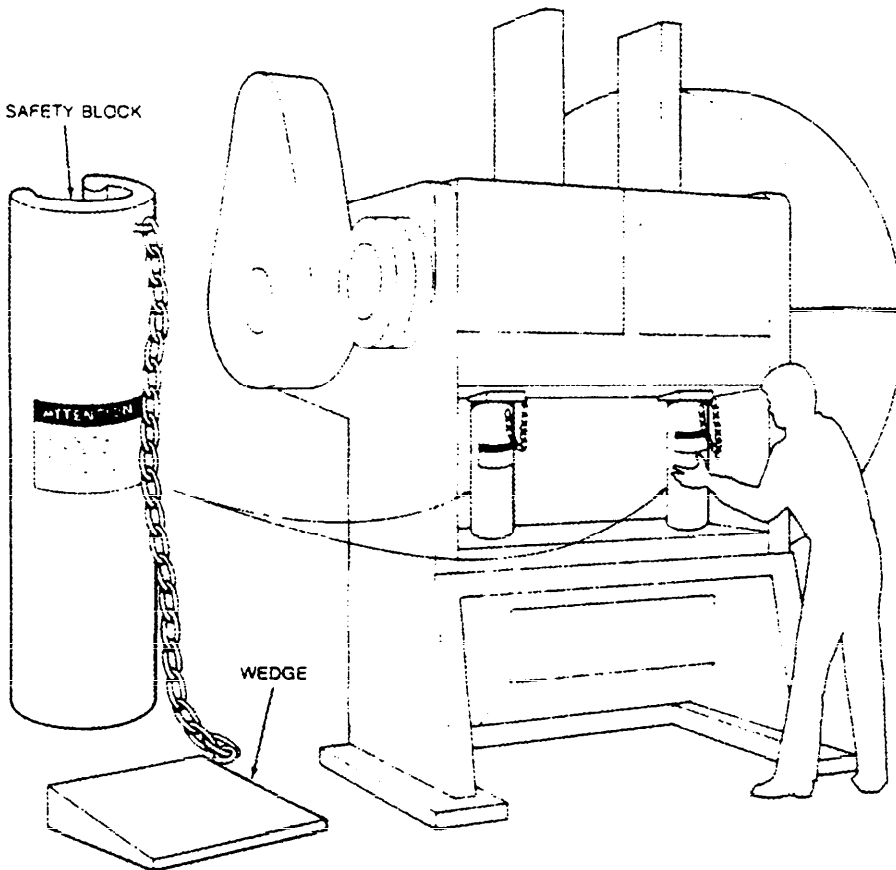
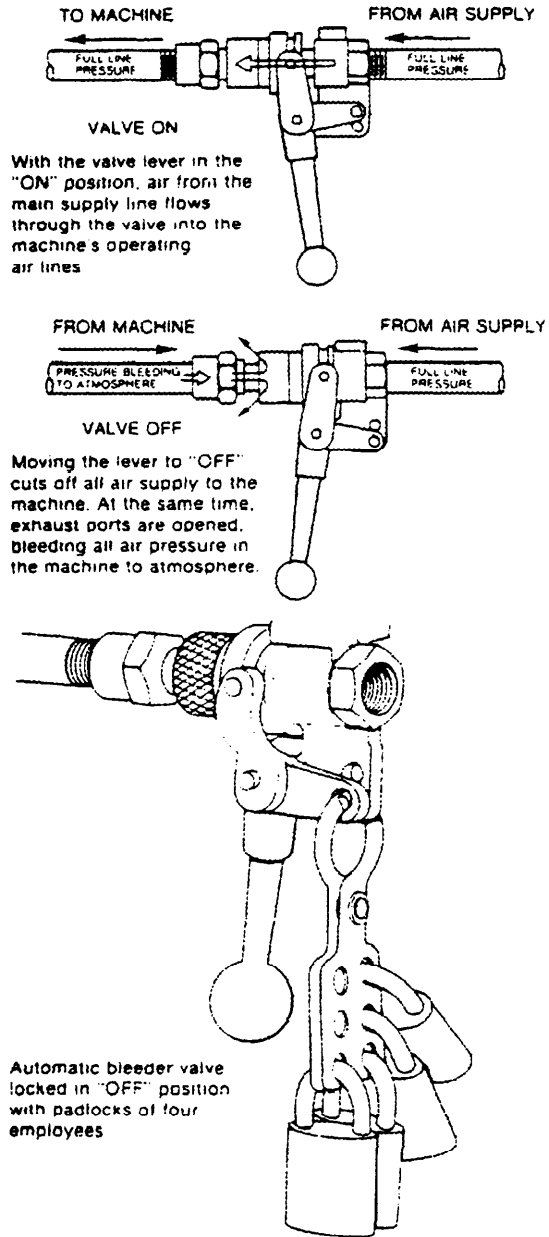

Figure 70.
Safety blocks installed on
power press

Mechanical: Figure 70 shows safety blocks being used as an additional safeguard on a mechanical power press, even though the machine has been locked out. The safety blocks prevent the ram from coming down under its own weight.

Pneumatic and hydraulic: Figure 71 shows a lockout valve. The lever-operated air valve used during repair or shutdown to keep a pneumatic-powered machine or its components from operating can be locked open or shut. Before the valve can be opened, everyone working on the machine must use his or her own key to release the lockout. A sliding-sleeve valve exhausts line pressure at the same time it cuts off the air supply. Valves used to lock out pneumatic or hydraulic-powered machines should be

Figure 71.
Lockout valve



designed to accept locks or lockout adapters and should be capable of "bleeding off" pressure residues that could cause any part of the machine to move.

In shops where several maintenance persons might be working on the same machine, multiple lockout devices accommodating several padlocks are used. The machine cannot be reactivated until each person removes his or her lock. As a matter of general policy, lockout control is gained by the procedure of issuing personal padlocks to each maintenance or repair person; no one but that person can remove the padlock, thereby each worker controls the power systems.

Whenever machines or equipment are serviced, there are hazards encountered by the employees performing the servicing or maintenance which are unique to the repair or maintenance procedures being conducted. These hazards may exist due to the failure of the employees doing the servicing or maintenance to stop the machine being worked on. Even if the machine has been stopped, the machine can still be hazardous due to the possibility of the machine becoming reenergized or restarting.

In order to prevent these hazards, each machine or piece of equipment should be safeguarded during the conduct of servicing or maintenance by: (1) notifying all affected employees (usually machine or equipment operators or users) that the machine or equipment must be shut down to perform some maintenance or servicing; (2) stopping the machine; (3) isolating the machine or piece of equipment from its energy source; (4) locking out or tagging out the energy source; (5) relieving any stored or residual energy; and (6) verifying that the machine or equipment is isolated from the energy source. Although this is the general rule, there are exceptions when the servicing or maintenance is not hazardous for an employee, when the servicing which is conducted is minor in nature, done as an integral part of production, and the employer utilizes alternative safeguards which provide effective protection as is required by 29 CFR 1910.212 or other specific OSHA standards.

When the servicing or maintenance is completed, there are specific steps which must be taken to return the machine or piece of equipment to service. These steps include (1) inspection of the machine or equipment to ensure that all guards and other safety devices are in place and functional, (2) checking the area to ensure that energization and start up of the machine or equipment will not endanger employees, (3) removal of the lockout devices, (4) reenergization of the machine or equipment, and (5) notification of affected employees that the machine or equipment may be returned to service.

The steps to lockout described above are only a part of the total energy control program which must exist in the workplace. In addition, the employee should have written procedures for all machines and equipment, employees must be trained in their duties and responsibilities under the energy control program and periodic inspections must be conducted to maintain the effectiveness of the program.

Figure 72 provides a functional flow diagram of the functions necessary during the conduct of a viable servicing/maintenance operation during which the equipment must be isolated and locked out.

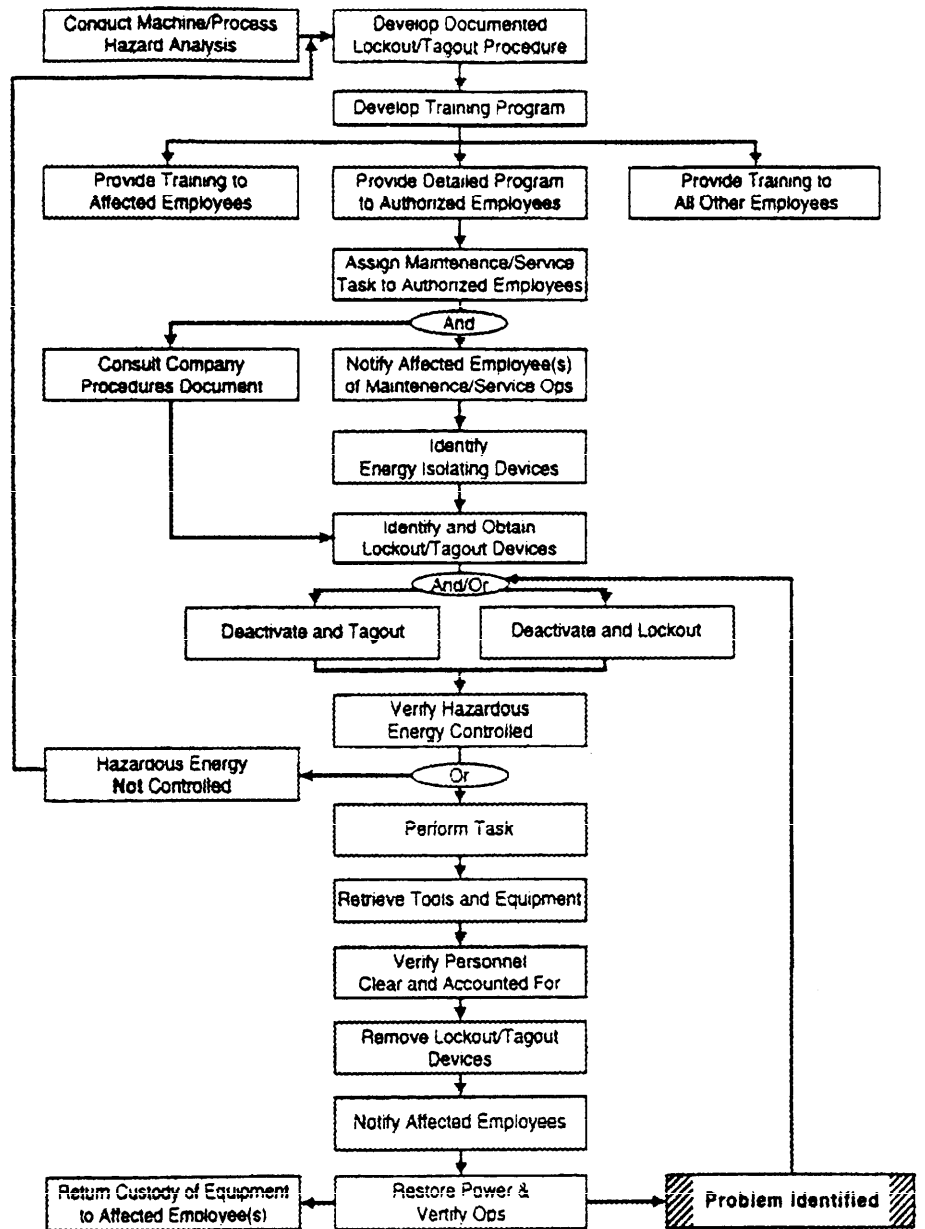

Figure 72.
Functional flow diagram for
implementation of
lockout/tagout requirements

The maintenance and repair facility in the plant deserves consideration here. Are all the right tools on hand and in good repair? Are lubricating oils and other common supplies readily available and safely stored? Are commonly used machine parts and hardware kept in stock so that the crews are not encouraged (even obliged) to improvise, at the risk of doing an unsafe repair, or to postpone a repair job? And don't overlook the possibility that maintenance equipment itself may need guarding of some sort. The same precaution applies to tools and machines used in the repair shop. Certainly, the maintenance and repair crew are entitled to the same protection that their service provides to the machine operators in the plant.

The Utilization of Industry Consensus Standards

OSHA uses industry consensus standards, related to the safe operation of equipment, as guidance of the industry accepted practice for safe operations. Industry consensus standards which describe equipment configuration or design but which do not describe safe and/or healthful use and operation of the equipment are of limited assistance to OSHA. In any event, even when an industry consensus standard addresses safety/health considerations, OSHA may determine that the safety/health practices described by that industry consensus standard are deficient when related to the requirement(s) set forth by the pertinent OSHA regulation(s). However, many of the various ANSI safety standards devoted to the safe use of equipment and machines are pertinent and provide valuable guidance as they relate to the multitude of safe operating procedures regularly discussed in ANSI safety standards.

All of the requirements of 29 CFR 1910.212, are applicable to machines found in industry. Paragraph (a) (1), requires that employees be protected from the hazards created by the point of operation, ingoing nip points, and rotating parts. Paragraph (a) (2), describes the manner in which guards shall be affixed. The proper application of devices are not described; therefore, other similar OSHA or pertinent industry standards must be referred to for guidance. Paragraph (a) (3) describes, with particularity, the requirements for safeguarding the point of operation.

The OSHA standard specifically requires that at the point of operation, "the guarding device shall be in conformity with any appropriate standards therefore, or in the absence of applicable specific standards, shall be so designed and constructed as to prevent the operator from having any part of his body in the danger zone during the operating cycle." Applicable standards include any similar OSHA standard or any OSHA adopted industry consensus standard(s) which provide for the safety of the operator during the operating cycle. However, any specific industry consensus standard, such as an ANSI standard for the particular machine or equipment, should be used for guidance relative to the accepted procedures for safeguarding workers and operators from the recognized hazards of the equipment.

Employers who comply with the requirements of an industry consensus standard rather than a specific OSHA standard, where such compliance deviates from the OSHA requirements but provides for a more conservative safeguarding concept, are categorized as having created a de minimis violation of the specific OSHA standard. (A de minimis violation is a violation of an OSHA standard that has no direct or immediate relationship to safety or health. Such de minimis violations require no correction and result in no penalty.)

OSHA encourages employers to abide by the more current industry consensus standards since those standards are more likely to be abreast of the state of the art than an applicable OSHA standard may be. Furthermore, the industry consensus standards will usually discuss a variety of techniques for averting exposure to the identified hazards of the machine or process.

Listing of Specific ANSI Safety Standards

ANSI B11.1-1982	Mechanical Power Presses
ANSI B11.2-1982	Hydraulic Power Presses
ANSI B11.3-1982	Power Press Brakes
ANSI B11.4-1983	Shears
ANSI B11.5-1988	Iron Workers
ANSI B11.6-1984	Lathes
ANSI B11.7-1985	Cold Headers and Cold Formers
ANSI B11.8-1983	Drilling, Milling, and Boring Machines
ANSI B11.9-1975	Grinding Machines
ANSI B11.10-1983	Metal Sawing Machines
ANSI B11.11-1985	Gear Cutting Machines
ANSI B11.12-1983	Roll Forming and Roll Bending Machines
ANSI B11.13-1983	Single- and Multiple-Spindle Automatic Screw/Bar and Chucking Machines
ANSI B11.14-1983	Coil Slitting Machines/Equipment
ANSI B11.15-1984	Pipe, Tube, and Shape Bending Machines
ANSI B11.17-1982	Horizontal Hydraulic Extrusion Presses
ANSI B11.18-1985	Machinery and Machine Systems for the Processing of Coiled Strip, Sheet, and Plate
ANSI B11.19-1990	Machine Tools, Safeguarding
ANSI B11.20-1991	Manufacturing Systems/Cells
(ANSI B15.1-1994/6)	Power Transmission Apparatus
ANSI B19.1-1990	Air Compressor Systems
ANSI B19.3-1986/90	Compressors for Process Industries
ANSI B20.1-1990	Conveyors and Related Equipment
ANSI B24.1-1985	Forging Machinery
ANSI B28.6-1983	Rubber Machinery, Hose
ANSI B28.7-1983	Rubber Machinery, Hose
ANSI B28.8-1983	Rubber Machinery, Hose
ANSI B28.9-1983	Rubber Machinery, Hose
ANSI B28.10-1986	Rubber Machinery, Endless Belt
ANSI B30.16-1987	Overhead Hoists
ANSI B151.1-1990	Plastics Injection Molding Machinery, Horizontal
ANSI B151.2-1982/88	Plastics Machinery, Film Casting
ANSI B151.3-1982/88	Plastics Machinery, Screen Changers
ANSI B151.4-1982/88	Plastics Machinery, Blown Film Takeoff & Auxiliary Equipment
ANSI B151.5-1982/88	Plastics Machinery, Film & Sheet Winding

ANSI B151.6-1982/88	Plastics Machinery, Slit Tape & Monofilament Postextrusion Equipment
ANSI B151.7-1982/88	Plastics & Rubber Extrusion Machinery
ANSI B151.11-1982	Plastics Machinery, Granulators, Pelletizers, & Dicers
ANSI B151.15-1985	Plastics Machinery, Extrusion Blow Molding
ANSI B151.21-1986	Plastics Machinery, Injection Blow Molding
ANSI B151.25-1988	Plastics Machinery, Injection Molding
ANSI B152.2-1982	Permanent-Mold Casting Machines (Other than Gray Iron)
ANSI B153.1-1990	Automotive Lifts
ANSI B155.1-1986	Packaging Machinery
ANSI B169.1-1990	Envelope Manufacturing Machinery
ANSI B176-1985	Copper-Alloy Diecasting
ANSI B177.2-1977/82	Printing Ink Vertical Post Mixers
ANSI/NEMA ICS2:225.95-1983	Interlocking Control Circuits for Personnel Protection
ANSI/NFPA 79-1991	Electrical Standard for Industrial Machinery
ANSI/RIA R15.06-1986	Industrial Robots and Robot Systems
ANSI Z8.1-1972	Commercial Laundry & Dry-Cleaning Equipment
ANSI Z241.1-1989	Foundry, Sand Prep., Molding, & Core-Making
ANSI Z241.2-1989	Foundry, Melting & Pouring of Metals
ANSI Z241.3-1989	Foundry, Cleaning & Finishing of Castings
ANSI Z245.1-1984	Refuse Collecting & Compacting Equipment
ANSI Z245.3-1977/83	Stability of Refuse Bins
ANSI Z245.5-1982	Baling Equipment
ANSI Z268.1-1082	Metal Scrap Processing Equipment

Robotics In the Workplace

Robot Applications

Robots are machines that load and unload stock, assemble parts, transfer objects, or perform other tasks.

Robots are used for replacing humans who were performing unsafe, hazardous, highly repetitive, and unpleasant tasks. They are utilized to accomplish many different types of application functions such as material handling, assembly, arc welding, resistance welding, machine tool load/unload functions, painting/spraying, etc.

Studies in Sweden and Japan indicate that many robot accidents have not occurred under normal operating conditions but rather during programming, program touch-up, maintenance, repair, testing, setup, or adjustment. During many of these operations, the operator, programmer or corrective maintenance worker may temporarily be within the robot's working envelope where unintended operations could result in injuries.

All industrial robots are either servo or non-servo controlled. Servo robots are controlled through the use of sensors which are employed to continually monitor the robot's axes for positional and velocity feedback information. This feedback information is compared on an on-going basis to pre-taught information which has been programmed and stored in the robot's memory.

Non-servo robots do not have the feedback capability of monitoring the robot's axes and velocity and comparing with a pre-taught program. Their axes are controlled through a system of mechanical stops and limit switches to control the robot's movement.

Type of Potential Hazards

The use of robotics in the workplace also can pose potential mechanical and human hazards.

Mechanical hazards might include workers colliding with equipment, being crushed, or trapped by equipment, or being injured by falling equipment components. For example, a worker could collide with the robot's arm or peripheral equipment as a result of unpredicted movements, component malfunctions, or unpredicted program changes.

A worker could be injured by being trapped between the robot's arm and other peripheral equipment or being crushed by peripheral equipment as a result of being impacted by the robot into this equipment.

Mechanical hazards also can result from the mechanical failure of components associated with the robot or its power source, drive components, tooling or end-effector, and/or peripheral equipment. The failure of gripper mechanisms with resultant release of parts, or the failure of end-effector power tools such as grinding wheels, buffing wheels, deburring tools, power screwdrivers, and nut runners to name a few.

Human errors can result in hazards both to personnel and equipment. Errors in programming, interfacing peripheral equipment, connecting input /output sensors, can all result in unpredicted movement or action by the robot which can result in personnel injury or equipment breakage.

Human errors in judgment result frequently from incorrectly activating the teach pendant or control panel. The greatest human judgment error results from becoming so familiar with the robot's redundant motions that personnel are too trusting in assuming the nature of these motions and place themselves in hazardous positions while programming or performing maintenance within the robot's work envelope.

Robots in the workplace are generally associated with machine tools or process equipment. **Robots are machines**, and as such must be safeguarded in ways similar to those presented for any hazardous remotely controlled machine.

Various techniques are available to prevent employee exposure to the hazards which can be imposed by robots. The most common technique is through the installation of perimeter guarding with interlocked gates. A critical parameter relates to the manner in which the interlocks function. Of major concern is whether the computer program, control circuit, or the primary power circuit, is interrupted when an interlock is activated. The various industry standards should be investigated for guidance; however, it is generally accepted that the primary motive power to the robot should be interrupted by the interlock.

The ANSI safety standard for industrial robots, ANSI/RIA R15.06-1986, is very informative and presents certain basic requirements for protecting the worker. However, when a robot is to be used in a workplace, the employer should accomplish a comprehensive operational safety/health hazard analysis and then devise and implement an effective safeguarding system which is fully responsive to the situation. (Various effective safeguarding techniques are described in ANSI B11.19-1990.)

Cellular Manufacturing Systems

A recent development in manufacturing technology has given rise to a manufacturing concept known as Manufacturing Systems/Cells, or Cellular Manufacturing Systems. These systems of integrated industrial machines, linked by a material handling system and operated by (controlled by) a programmable electronic system (computer) are capable of manufacturing discrete parts or assemblies. The safety of employees exposed to these systems is of first order importance.

Because a system is to be safeguarded it is logical that a system hazard analysis will yield the parameters of the safeguarding system required. Figures 73 through 75 depict typical cellular system concepts and safeguarding considerations.

ANSI B11.20-1991, should be referred to for assistance when a cellular manufacturing system is envisioned.

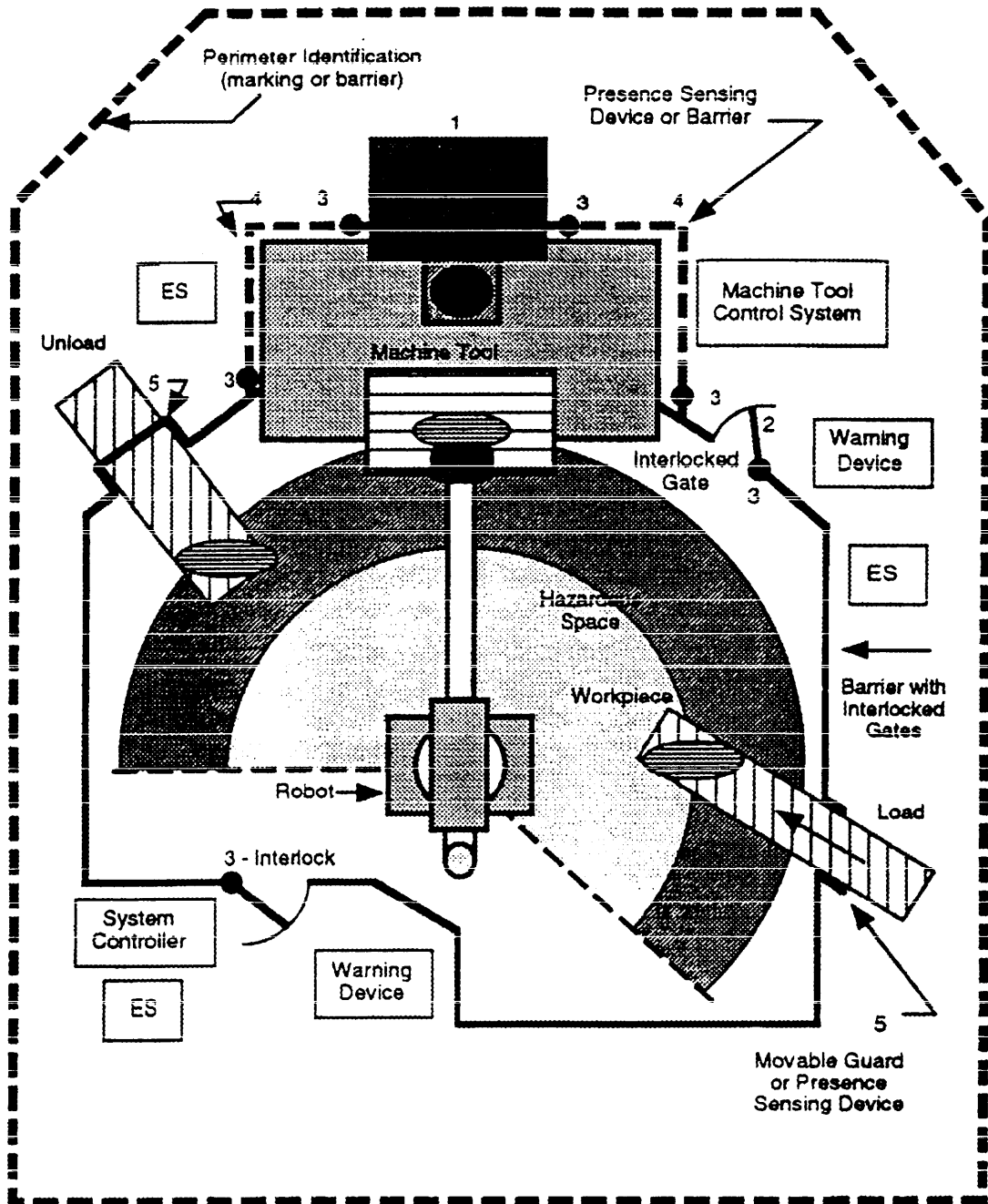

Figure 73. Typical manufacturing system/cell using a robot as the material handling system showing perimeter marking/barrier, fixed barriers with interlocked gates, presence sensing devices, warning devices, and additional system emergency stop devices

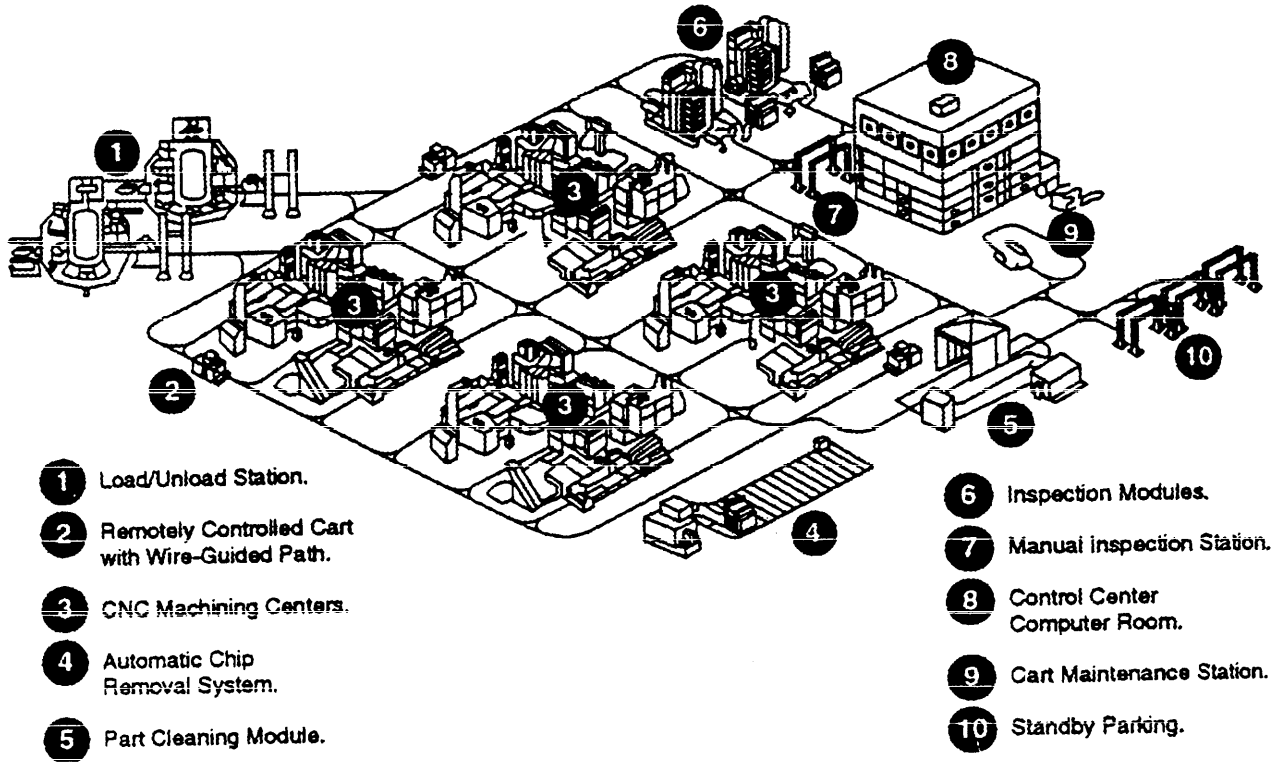

Figure 74. Manufacturing system composed of several cells

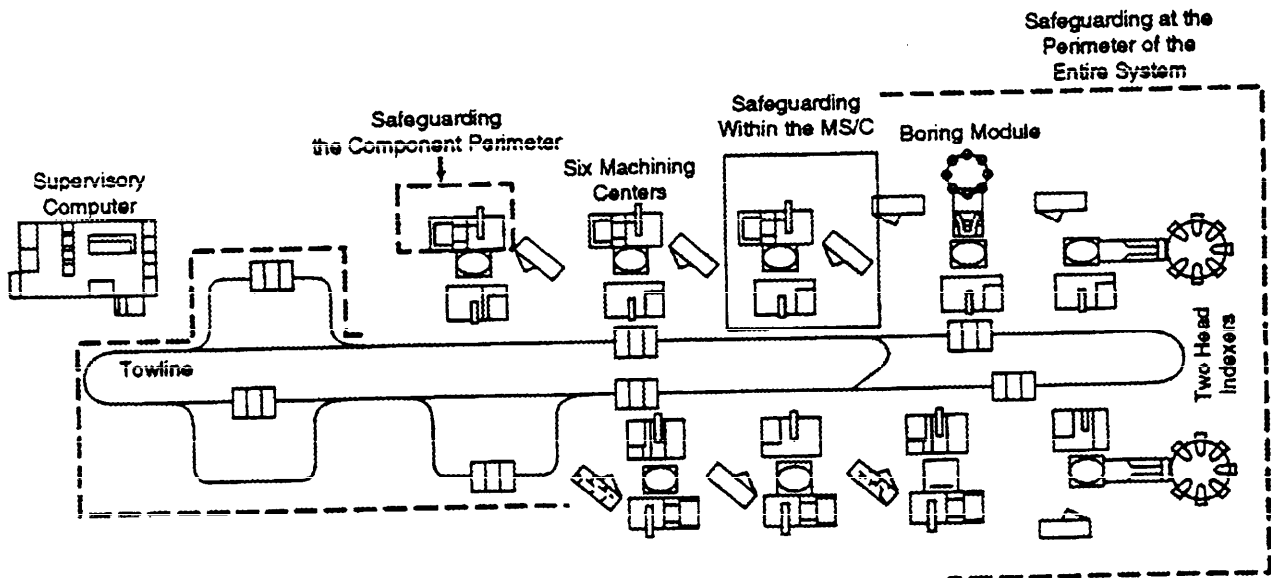

Figure 75. Areas to be considered for safeguarding

Ergonomic Considerations of Machine Safeguarding

The ergonomic considerations of machine safeguarding are as significant to the safety and health of the worker as are the multitude of techniques to accomplish safety and health in the workplace. Worker stress and fatigue can be averted by creditable work setups and well integrated safeguarding. The various industry consensus standards are only now beginning to address this issue. Future evaluations of safeguarding are likely to devote more attention to this aspect.

Cooperation and Assistance

Safety in the workplace demands cooperation and alertness on everyone's part. Supervisors, operators, and other workers who notice hazards in need of safeguarding, or existing systems that need repair or improvement, should notify the proper authority immediately.

Supervisors have these additional, special responsibilities with regard to safety in the workplace: encouraging safe work habits and correcting unsafe ones; explaining to the worker all the potential hazards associated with the machines and processes in the work area; and being responsive to employer requests for action or information regarding machine hazards. The first-line supervisor plays a pivotal role in communicating the safety needs of the worker to management and the employer's safety rules and policies to the worker.

Sometimes the solution to a machine safeguarding problem may require expertise that is not available in a given establishment. The readers of this manual are encouraged to find out where help is available and, when necessary, to request it.

The machine's manufacturer is often a good place to start when looking for assistance with a safeguarding problem. Manufacturers can often supply the necessary literature or advice. Insurance carriers, too, will often make their safety specialists available to the establishments whose assets they insure. Union safety specialists can also lend significant assistance.

Some government agencies offer consultation services, providing for on-site evaluation of workplaces and the recommendation of possible hazard controls. OSHA funds one such program, which is offered free of charge to employers in every state. Delivered by state governments or private contractors, the consultation program is completely separate from the OSHA inspection effort; no citations are issued and no penalties are proposed. The trained professional consultants can help employers recognize hazards in the workplace and can suggest general approaches for solving safety and health problems. In addition, the consultant can identify sources of other available help, if necessary.

Anyone with questions about Federal standards, about the requirements for machine safeguarding, or about available consultation services should contact OSHA. (See the list of OSHA Regional Offices in the back of this publication.)

Machine Guarding Checklist

Answers to the following questions should help the interested reader determine the safeguarding needs of his or her own workplace, by drawing attention to hazardous conditions or practices requiring correction.

Requirements for All Safeguards

	Yes	No
1. Do the safeguards provided meet the minimum OSHA requirements?	___	___
2. Do the safeguards prevent workers' hands, arms, and other body parts from making contact with dangerous moving parts?	___	___
3. Are the safeguards firmly secured and not easily removable?	___	___
4. Do the safeguards ensure that no objects will fall into the moving parts?	___	___
5. Do the safeguards permit safe, comfortable, and relatively easy operation of the machine?	___	___
6. Can the machine be oiled without removing the safeguard?	___	___
7. Is there a system for shutting down the machinery before safeguards are removed?	___	___
8. Can the existing safeguards be improved?	___	___

Mechanical Hazards

The point of operation:

1. Is there a point-of-operation safeguard provided for the machine?	___	___
2. Does it keep the operator's hands, fingers, body out of the danger area?	___	___
3. Is there evidence that the safeguards have been tampered with or removed?	___	___
4. Could you suggest a more practical, effective safeguard?	___	___
5. Could changes be made on the machine to eliminate the point-of-operation hazard entirely?	___	___

Power transmission apparatus:

1. Are there any unguarded gears, sprockets, pulleys, or flywheels on the apparatus?	___	___
2. Are there any exposed belts or chain drives?	___	___
3. Are there any exposed set screws, key ways, collars, etc.?	___	___
4. Are starting and stopping controls within easy reach of the operator?	___	___
5. If there is more than one operator, are separate controls provided?	___	___

Other moving parts:

1. Are safeguards provided for all hazardous moving parts of the machine including auxiliary parts?	___	___
---	-----	-----

Nonmechanical Hazards

1. Have appropriate measures been taken to safeguard workers against noise hazards?	___	___
2. Have special guards, enclosures, or personal protective equipment been provided, where necessary, to protect workers from exposure to harmful substances used in machine operation?	___	___

Electric Hazards

1. Is the machine installed in accordance with National Fire Protection Association and National Electrical Code requirements?	___	___
2. Are there loose conduit fittings?	___	___
3. Is the machine properly grounded?	___	___
4. Is the power supply correctly fused and protected?	___	___
5. Do workers occasionally receive minor shocks while operating any of the machines?	___	___

Training

Yes No

- 1. Do operators and maintenance workers have the necessary training in how to use the safeguards and why? ___ ___
- 2. Have operators and maintenance workers been trained in where the safeguards are located, how they provide protection, and what hazards they protect against? ___ ___
- 3. Have operators and maintenance workers been trained in how and under what circumstances guards can be removed? ___ ___
- 4. Have workers been trained in the procedures to follow if they notice guards that are damaged, missing, or inadequate? ___ ___

Protective Equipment and Proper Clothing

- 1. Is protective equipment required? ___ ___
- 2. If protective equipment is required, is it appropriate for the job, in good condition, kept clean and sanitary, and stored carefully when not in use? ___ ___
- 3. Is the operator dressed safely for the job (i.e., no loose-fitting clothing or jewelry)? ___ ___

Machinery Maintenance and Repair

- 1. Have maintenance workers received up-to-date instruction on the machines they service? ___ ___
- 2. Do maintenance workers lock out the machine from its power sources before beginning repairs? ___ ___
- 3. Where several maintenance persons work on the same machine, are multiple lockout devices used? ___ ___
- 4. Do maintenance persons use appropriate and safe equipment in their repair work? ___ ___
- 5. Is the maintenance equipment itself properly guarded? ___ ___
- 6. Are maintenance and servicing workers trained in the requirements of 29 CFR 1910.147, lockout/tagout hazard, and do the procedures for lockout/tagout exist before they attempt their tasks? ___ ___

Worker Rights and Responsibilities

If you are a worker, you have the right to:

- request an OSHA inspection for workplace hazards, violations of OSHA standards, or violations of the OSH Act (your name will be kept confidential on request);
- have an authorized employee representative accompany the OSHA compliance officer on the workplace inspection;
- confer informally with the OSHA compliance officer (in private, if preferred);
- be notified by your employer of any citations issued for alleged violations of standards at the workplace, and of your employer's requests for variances or for changes in the abatement period;
- contest the abatement time set in any citation issued to your employer by OSHA;
- file a complaint with OSHA if you believe that you have been dismissed, demoted, or otherwise discriminated against for exercising rights under OSHA;
- file a complaint with Federal OSHA authorities if your State agency fails to administer a State program as effectively as required by OSHA;
- ask OSHA about any tests performed in your workplace, the results of inspections, and any decision not to take action on a complaint;
- receive information from your employer about hazards and safety measures applicable to the workplace, OSHA standards relevant to your job, and the record of accidents and illnesses in the workplace;
- ask that National Institute for Occupational Safety and Health evaluate and provide information on the substances used in your workplace;
- refuse to work in an imminent danger situation, under certain conditions;
- submit written information or comment to OSHA on the issuance, revocation, or modification of an OSHA standard and to request a public hearing; and
- observe the monitoring and measuring of toxic substances in the workplace if you are exposed, and to have access to any records of your exposure.

You also have the responsibility to:

- read the OSHA poster in the workplace;
- comply with all the OSHA standards, with all requirements of your State-approved plan (if any), and with the employer's safety and health rules;

- report any hazards immediately to your supervisor;
- report to your supervisor any job-related illness or injury; and
- cooperate fully with the OSHA compliance officer who inspects your workplace.

Bibliography

The following texts were used for reference in compiling this manual. This does not constitute an endorsement of the texts by the U.S. Department of Labor.

Accident Prevention Manual for Industrial Operations, 9th ed. National Safety Council, 1988, Chicago

Alphabetical Index of Industrial Safety Data Sheets, National Safety Council, 1990-91, Chicago

Cabinetmaking and Millwork: Feirer, John; Glenco Publishing Co., Peoria, IL

Dictionary of Terms Used in the Safety Profession: Tarrants, W.E., ed.; American Society of Safety Engineers, 1988, Park Ridge, IL

Disc Grinding-Safe Rules and Methods: Grinding Wheel Institute, Cleveland

Electrical Standard for Metalworking Machine Tools, NFPA 79: National Fire Protection Association, 1987, Quincy, MA

Fundamentals of Industrial Hygiene: Olishifski, Julian B. and McElroy, Frank E., eds.; National Safety Council, 1988, Chicago

General Industry Safety and Health Standards, Title 29 Code of Federal Regulations 1910.212-1910.222

Guards Illustrated, National Safety Council, 1987, Chicago

Industrial Ventilation, A Manual of Recommended Practice, 20th ed.: American Conference of Governmental Industrial Hygienists, Edward Brothers, 1988, Lansing, MI

Machine Tool Practice, White, Warren T., Kibbe, Richard R.; Prentice Hall, 1991, New York

Power Press Safety Manual, National Safety Council, 1989, Chicago

Safeguarding of Machinery, BS 5304: British Standards Institute, 1975, London

The Use, Care, and Protection of Abrasive Wheels, ANSI B7.1-1988: American National Standards Institute, New York

Safety Recommendations for Grinding Wheel Operation: Grinding Wheel Institute, Cleveland

Safety Requirements for the Construction, Care and Use of Cold Headers and Cold Formers, ANSI B11.7-1985, American National Standards Institute, 1985, New York

Safety Requirements for the Construction, Care and Use of Drilling, Milling, and Boring Machines, ANSI B11.8-1985, American National Standards Institute, New York

Safety Requirements for the Construction, Care, and Use of Horizontal Injection Molding Machines, ANSI B151.1-1990, American National Standards Institute, New York

Safety Requirements for the Construction, Care, and Use of Lathes, ANSI B11.6-1984: American National Standards Institute, New York

Safety Requirements for the Construction, Care, and Use of Iron Workers, ANSI B11.5-1975: American National Standards Institute, New York

Safety Requirements for the Construction, Care, and Use of Mechanical Power Presses, ANSI B11.1-1988: American National Standards Institute, New York

Safety Requirements for the Construction, Care and Use of Metal Sawing Machines, ANSI B11.10-1990: American National Standards Institute, New York

Safety Requirements for the Construction, Care, and Use of Packaging and Packaging-Related Converting Machinery, ANSI B155.1-1986: American National Standards Institute, New York

Safety Requirements for the Construction, Care, and Use of Power Press Brakes, ANSI B11.3-1982: American National Standards Institute, New York

Safety Requirements for the Construction, Care, and Use of Fasteners, Rivet Setting Equipment, ANSI B154.1-1984: American National Standards Institute, New York

Safety Requirements for the Construction, Care, and Use of Shears, ANSI B11.4-1983: American National Standards Institute, New York

Safety Requirements for the Construction, Care, and Use of Single and Multiple-Spindle Automatic Screw/Bar and Chucking Machines, ANSI B11.13-1983: American National Standards Institute, New York

Safety Requirements for Woodworking Machinery, ANSI 01.1-1975: American National Standards Institute, New York

Safety Specifications for Mills and Calenders in the Rubber and Plastics Industries, ANSI B28.1-1967: American National Standards Institute, New York

Safety Standard for the Mechanical Power Transmission Apparatus, ANSI B15.1-1984: The American Society of Mechanical Engineers, New York

Standard Handbook for Mechanical Engineers, 9th ed: Baumeister, Theodore, ed.; McGraw-Hill, 1987, New York

States with Approved Plans

Commissioner

Alaska Department of Labor
P.O. Box 21149
Juneau, AK 99801
(907) 465-2700

Director

Industrial Commission of Arizona
800 W. Washington
Phoenix, AZ 85007
(602) 542-5795

Director

California Department of Industrial Relations
455 Golden Gate Avenue
4th Floor
S. San Francisco, CA 94102
(415) 703-4590

Commissioner

Connecticut Department of Labor
200 Folly Brook Boulevard
Wethersfield, CT 06109
(203) 566-5123

Director

Hawaii Department of Labor and
Industrial Relations
830 Punchbowl Street
Honolulu, HI 96813
(808) 548-3150

Commissioner

Indiana Department of Labor
1013 State Office Building
100 North Senate Avenue
Indianapolis, IN 46204-2287
(317) 232-2665

Commissioner

Iowa Division of Labor Services
1000 E. Grand Avenue
Des Moines, IA 50319
(515) 281-3447

Commissioner

Workplace Standards
Kentucky Labor Cabinet
1049 U.S. Highway, 127
South Frankfort, KY 40601
(502) 564-3070

Commissioner

Maryland Division of Labor and Industry
Department of Licensing and Regulation
501 St. Paul Place, 2nd Floor
Baltimore, MD 21202-2272
(301) 333-4179

Director

Michigan Department of Labor
Victor Office Center
201 N. Washington Square
P.O. Box 30015
Lansing, MI 48933
(517) 373-9600

Director

Michigan Department of Public Health
3423 North Logan Street
Box 30195
Lansing, MI 48909
(517) 335-8022

Commissioner

Minnesota Department of Labor and Industry
443 Lafayette Road
St. Paul, MN 55155
(612) 296-2342

Director

Nevada Department of Industrial Relations
Division of Occupational Safety and Health
Capitol Complex
1370 S. Curry Street
Carson City, NV 89710
(702) 687-3032

Secretary

New Mexico Environment Dept.
Occupational Health and Safety Bureau
1190 St. Francis Drive
P.O. Box 26110
Santa Fe, NM 87502
(505) 827-2850

Commissioner

New York Department of Labor
State Office Building
Campus 12- Room 457
Albany, NY 12240
(518) 457-2741

Commissioner

North Carolina Department of Labor
4 West Edenton Street
Raleigh, NC 27601
(919) 733-7166

Administrator

Oregon Occupational Safety
and Health Division
Oregon Department of Insurance and Finance,
Room 160
Labor and Industries Building
Salem, OR 97310
(503) 378-3272

Secretary

Puerto Rico Department of Labor and
Human Resources
Prudencio Rivera Martinez Building
505 Munoz Rivera Avenue
Hato Rey, PR 00918
(809) 754-2119

Commissioner

South Carolina Department of Labor
3600 Forest Drive
P.O. Box 11329
Columbia, SC 29211-1329
(803) 734-9594

Commissioner

Tennessee Department of Labor
501 Union Building
Suite "A", 2nd Floor
Nashville, TN 37243-0655
(615) 741-2582

Administrator

Utah Occupational Safety and Health
160 East 300 South
P.O. Box 5800
Salt Lake City, UT 84110-5800
(801) 530-6900

Commissioner

Vermont Department of Labor and Industry
120 State Street
Montpelier, VT 05620
(802) 828-2765

Commissioner

Virgin Islands Department of Labor
2131 Hospital Street
Box 890
Christiansted
St. Croix, VI 00840-4666
(809) 773-1994

Commissioner

Virginia Department of Labor and Industry
Powers-Taylor Building
13 S. 13th Street
Richmond, VA 23219
(804) 786-2376

Director

Washington Department of
Labor and Industries
General Administration
Building
Room 334-AX-31
Olympia, WA 98504-0631
(206) 753-6307

Director

Department of Employment
Division of Employment Affairs
Occupational Safety and
Health Administration
Herschler Building
2nd Floor East
122 West 25th Street
Cheyenne, WY 82002
(307) 777-7786 or 777-7787

**U.S Department of Labor
Regional Offices for the
Occupational Safety and Health Administration**

Contact the OSHA Regional Office nearest you for the location of your OSHA Area Office

Region I

(CT,* MA, ME, NH, RI, VT*)
133 Portland Street
1st Floor
Boston, MA 02114
Telephone: (617) 565-7164

Region II

(NJ, NY,* PR,* VI*)
201 Varick Street
Room 670
New York, NY 10014
Telephone: (212) 337-2378

Region III

(DC, DE, MD,* PA, VA,* WV)
Gateway Building, Suite 2100
3535 Market Street
Philadelphia, PA 19104
Telephone: (215) 596-1201

Region IV

(AL, FL, GA, KY,* MS, NC,*
SC,* TN*)
1375 Peachtree Street, N.E.
Suite 587
Atlanta, GA 30367
Telephone: (404) 347-3573

Region V

(IL, IN,* MI,* MN,* OH, WI)
230 South Dearborn Street
Room 3244
Chicago, IL 60604
Telephone: (312) 353-2220

Region VI

(AR, LA, NM,* OK, TX)
525 Griffin Street
Room 602
Dallas, TX 75202
Telephone: (214) 767-4731

Region VII

(IA,* KS, MO, NE)
911 Walnut Street, Room 406
Kansas City, MO 64106
Telephone: (816) 426-5861

Region VIII

(CO, MT, ND, SD, UT,* WY*)
Federal Building, Room 1576
1961 Stout Street
Denver, CO 80294
Telephone: (303) 844-3061

Region IX

(American Samoa, AZ,* CA,*
Guam, HI,* NV,* Trust
Territories
of the Pacific)
71 Stevenson Street
Room 415
San Francisco, CA 94105
Telephone: (415) 744-6670

Region X

(AK,* ID, OR,* WA*)
1111 Third Avenue
Suite 715
Seattle, WA 98101-3212
Telephone: (206) 553-5930

*These states and territories operate their own OSHA-approved job safety and health programs (Connecticut and New York plans cover public employees only). States with approved programs must have a standard that is identical to, or at least as effective as, the federal standard.

Related Publications

ANSI/ASME Standards

- B11.2 Hydraulic Presses 1982
- B11.3 Power Press Brakes 1982
- B11.10 Metal Sawing Machines 1990
- B11.11 Gear Cutting Machines 1985
- B11.12 Roll-forming and Roll-bending Machines 1983
- B11.14 Coil Slitting Machines 1983
- B11.15 Pipe, Tube, and Shape Bending Machines 1984
- B11.16 Metal Powder Compacting Presses 1988
- B11.17 Horizontal Hydraulic Extrusion Presses 1982
- B11.18 Coiled Steel Sheet & Plate Processing Machines 1985

Copies of the above can be obtained from the American National Standards Institute, 7 West 42nd Street, New York, NY 10036, 13th Floor.

OSHA Publications

OSHA 2056 All About OSHA

OSHA 2019 Catalogue

OSHA 3000 Employer Rights & Responsibilities Following an OSHA Inspection

OSHA 3074 Hearing Conservation

OSHA 3021 OSHA: Employee Workplace Rights

A single free copy of the above materials can be obtained from OSHA field offices or OSHA Publications Office, Room N3101, Washington, DC 20210, (202) 523-9667. Please send a self-addressed label with your request.

SafeWorks. A one page periodic news sheet that provides a brief summary of the results of a small business employer's request for workplace safety and health assistance from OSHA-funded consultation services in all of the states and U.S. territories.

ErgoFacts. A one page news sheet that provides a brief summary of ergonomic hazards and the need for workplace safety and health assistance.

The above publications can be obtained from the U.S. Department of Labor, OSHA-OICA, Room N3647, Washington, DC 20210. Please send a self-addressed label with your request.

ISBN 0-16-037972-5



9 780160 379727

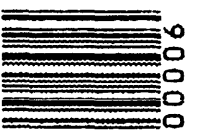

90000