



TECHNICAL REPORT  
NATICK/TR-92/042

AD \_\_\_\_\_

**A PORTABLE SORPTION TESTER  
FOR  
NONDESTRUCTIVE TESTING OF  
CHEMICAL PROTECTIVE GARMENTS**

Stephen Kerrin  
*Tracer Technologies*  
*San Diego, CA 92121*

Elizabeth Klemperer

August 1992

Final Report

August 1986 - January 1988

---

---

---

Approved for public release;  
distribution unlimited.

20020328 168

US ARMY NATICK RESEARCH, DEVELOPMENT AND ENGINEERING CENTER  
NATICK, MA 01760-5000

INDIVIDUAL PROTECTION DIRECTORATE

## DISCLAIMERS

The findings contained in this report are not to be construed as an official Department of the Army position unless so designated by other authorized documents.

Citation of trade names in this report does not constitute an official endorsement or approval of the use of such items.

## DESTRUCTION NOTICE

### For Classified Documents:

Follow the procedures in DoD 5200.22-M, Industrial Security Manual, Section II-19 or DoD 5200.1-R, Information Security Program Regulation, Chapter IX.

### For Unclassified/Limited Distribution Documents:

Destroy by any method that prevents disclosure of contents or reconstruction of the document.

Dec 12-22-92

REPORT DOCUMENTATION PAGE			Form Approved OMB No. 0704-0188	
Public reporting burden for this collection of information is estimated to average 7 hour per response, including the time for reviewing instructions, searching existing data sources, gathering and maintaining the data needed, and completing and reviewing the collection of information. Send comments regarding this burden estimate or any other aspect of this collection of information, including suggestions for reducing this burden, to Washington Headquarters Services, Directorate for Information Operations and Reports, 1215 Jefferson Davis Highway, Suite 1204, Arlington, VA 22202-4302, and to the Office of Management and Budget, Paperwork Reduction Project (0704-0188), Washington, DC 20503.				
1. AGENCY USE ONLY (Leave blank)	2. REPORT DATE August 1992	3. REPORT TYPE AND DATES COVERED FINAL Aug 1986 - Jan 1988		
4. TITLE AND SUBTITLE A Portable Sorption Tester for Nondestructive Testing of Chemical Protective Garments			5. FUNDING NUMBERS DAAK60-85-C-0076 DAAK60-89-C-1019	
6. AUTHOR(S) Stephen Kerrin* and Elizabeth Klemperer				
7. PERFORMING ORGANIZATION NAME(S) AND ADDRESS(ES) * Tracer Technologies 5820 Oberlin Drive San Diego, CA 92121			8. PERFORMING ORGANIZATION REPORT NUMBER NATICK/TR-92/042	
U.S. Army Natick RD&E Center Kansas Street Natick, MA 01760-500				
9. SPONSORING/MONITORING AGENCY NAME(S) AND ADDRESS(ES) U.S. Army Natick Research, Development and Engineering Center ATTN: STRNC-I TP Kansas Street Natick, MA 01760-5019			10. SPONSORING/MONITORING AGENCY REPORT NUMBER	
11. SUPPLEMENTARY NOTES				
12a. DISTRIBUTION / AVAILABILITY STATEMENT Approved for public release; distribution unlimited.			12b. DISTRIBUTION CODE	
13. ABSTRACT (Maximum 200 words) A prototype portable instrument was developed to measure, nondestructively, sorptive capacity of chemical protective garments in the field. The instrument contains four major subsystems: flow control, detection, microprocessor controller, and sample cell. A low-boiling halocarbon mimics carbon tetrachloride, the standard test vapor. A very low flow mass flow controller mixes challenge from a pressurized cylinder with a controlled flow of air from a diaphragm pump. A double sample cell is used in order to make detection by thermal conductivity specific for the challenge gas. Measurement, control, and operator interface are under the control of a microprocessor. A keypad is used for operator input. A thermal printer-plotter prints default and operator input conditions and plots the breakthrough curve. Total challenge at break time is printed. Leak-tight seal of intact, double-layer Battledress Overgarment material in the cell was achieved using tapered stainless steel cups with inset gaskets. Natick found the portable tester to display excellent repeatability. Correlation with carbon tetrachloride acceptance tests was carried out on stockpiled overgarments.				
14. SUBJECT TERMS NONDESTRUCTIVE TESTING CHEMICAL PROTECTION PROTECTIVE OVERGARMENTS			15. NUMBER OF PAGES 37	
SORPTION PROTOTYPES PORTABLE TESTER			16. PRICE CODE	
UNIFORMS ACTIVATED CARBON TOXIC VAPOR				
17. SECURITY CLASSIFICATION OF REPORT UNCLASSIFIED	18. SECURITY CLASSIFICATION OF THIS PAGE UNCLASSIFIED	19. SECURITY CLASSIFICATION OF ABSTRACT UNCLASSIFIED	20. LIMITATION OF ABSTRACT SAR	

## TABLE OF CONTENTS

	Page
List of Illustrations	v
Preface	vii
1.0 Introduction	1
2.0 Instrument Development	2
2.1 Instrument Description	2
2.1.1 Thermal Conductivity Detector	2
2.1.2 Challenge Source and Flow Control	6
2.1.3 Microprocessor Controller	7
2.1.4 Software	7
2.1.5 The Nondestructive Cell	8
3.0 Operation and Example Runs	10
4.0 Correlation with Standard Test	13
5.0 Summary and Conclusions	18
References	19
Appendix A Operations Manual	21
Appendix B The Sample Drying System	26
Distribution List	28

## LIST OF ILLUSTRATIONS

Figure	Page
1. Schematic Diagram of Essential Components of Portable Sorption Tester	3
2. Thermal Conductivity Detector Bridge	4
3. Phase I Instrument Configuration	5
4. The Double Cell	9
5. The Nondestructive Cell Mounted in the Portable Tester	10
6. Typical Test Run in Prototype I	11
7. Typical Test Run in Prototype II	12
8. Reproducibility in the Portable Sorption Tester	13
9. Correlation of Dynamic Sorption Tests in the Portable Instrument and in the Dawson Apparatus	14
10. Heightened $\text{CCl}_4$ Sorption Values are Obtained on Undried Samples	15
11. Correlation of Sorption Values Obtained on Partner Samples (Dried) in the Portable Sorption Tester with Freon 114 and (Undried) in the Dawson Apparatus with $\text{CCl}_4$	16
12. Linearity of Sorption vs Sample Weight for Samples Taken from the Same Roll of Material	17
B.1. Schematic of Portable Sorption Tester with Sample Drier	27
<u>Table</u>	
1. Comparison of Simulant and Challenge Vapor Conditions	14

## PREFACE

The project to develop a prototype instrument to determine sorption by stored chemical protective garments in the field was sponsored by the U.S. Army Natick Research, Development and Engineering Center. Contract DAAK60-85-C-0076 under the Small Business Innovative Research (SBIR) program covered work from August 1986 to January 1988 to produce a first prototype for a portable tester. Jointly under Materials Testing Technology program task AM86 9427, an improved second prototype was developed by Tracer Technologies, San Diego, CA, contract DAAK60-89-C-1019, and a nondestructive cell was added by Natick, who correlated the instrument's performance with the carbon tetrachloride Dawson acceptance test for sorptive protective material, specified in MIL-C-43858. A sample drying system which permits testing at high ambient relative humidity was installed by Industrial and Biomedical Sensors Corp., Waltham, MA.

The citation of trade names in this report does not constitute an official endorsement of the use of a product or item.

## A PORTABLE SORPTION APPARATUS FOR TESTING PERMEABLE CHEMICAL PROTECTIVE GARMENTS

### 1.0 INTRODUCTION

This report describes the development and operation of an instrument to determine sorption by chemical protective garments in the field. A first prototype of the portable instrument was developed by Tracer Technologies, Inc. under a Phase II Small Business Innovative Research contract. After testing at Natick, design improvements and incorporation of a nondestructive cell were carried out under a Materials Testing Technology program.

The use of breakthrough time of chemical vapor challenge as a quantitative test for chemical protection afforded by activated carbon materials is a valid measure of the carbon sorptive capacity. The Dawson test (1) with agent vapor challenge was originally used to test for six hours of protection by chloramide-impregnated protective cloth at the following test conditions:

- o A 20 microgram per liter estimated mustard concentration in air from the settled drops after a bomb burst.
- o Wind entering the fabric at 10 cm/min.
- o Skin temperature, 90 °F (32 °C), and humidity, 80% relative humidity (RH).

Higher sorptive capacity of activated carbon materials such as the impregnated polyurethane foam (Type III fabric MIL-C-43858(2)) in the Battledress Overgarment (BDO) affords extended protection against toxic vapor and against the more concentrated challenge of liquid droplets. MIL-C-43858 requires a minimum carbon tetrachloride sorption for Type III fabric of 1.8 milligrams per square centimeter. A six-hour agent vapor test applies only 0.07 milligram HD per square centimeter. The agent vapor breakthrough time for BDO is greater than 150 hours.

It is convenient to test the BDO uniforms with a volatile simulant that can be applied as concentrated vapor to shorten the test time (3). Carbon tetrachloride, boiling point 76 °C, is used at a concentration of 5 milligrams per liter, as compared to mustard, boiling point 217 °C, at 20 micrograms per liter. A 150 hour mustard vapor challenge is simulated by a 36 minute carbon tetrachloride challenge. Although the molecular weights are the same, there is a greater accumulation of sorption at breakthrough for the less volatile mustard gas, but only at dry conditions. It is fortuitous that cumulative sorption at breake time for mustard at 80%RH and for dry carbon tetrachloride are the same (4).

Concocting a known challenge of vapor is accomplished by bubbling air or nitrogen through liquid agent or simulant in a constant temperature (ice) bath at a regulated low volume flow rate and then diluting it with a regulated high flow at 90 °F (32 °C). Constant carrier flow regulation is attained with precision electronic mass flow controllers.

For the design of a portable sorption tester, Tracer Technologies obtained a very low-flow mass flow controller to regulate a pure vapor, as an alternate method for producing a known vapor concentration flow. The Phase I effort (5) demonstrated the feasibility of using as a volatile surrogate for carbon tetrachloride (CCl<sub>4</sub>) the nontoxic halocarbon 1,2 dichlorotetrafluoroethane (Freon<sup>(R)</sup> 114), b.p. 4 °C. In preliminary tests with premixed dilutions, the same penetration profile was followed by these two simulants. With this behavior of a gas at room temperature, repetitive automated tests may be accomplished routinely.

## 2.0 INSTRUMENT DEVELOPMENT

Development of the prototype Portable Sorption Tester was undertaken in modular fashion. The following discussion will present the basis for the instrument, description of the functional modules, and discussion of the problems encountered.

### 2.1 INSTRUMENT DESCRIPTION

The instrument contains three major subsystems. These are the flow controller, detector, and microprocessor controller. A schematic diagram of the major components is presented in Figure 1. Discussion will begin with the detection method, as development of the flow control system was dictated by detector requirements.

#### 2.1.1 THERMAL CONDUCTIVITY DETECTOR

A thermal conductivity detector is used to measure breakthrough penetration of the Freon 114. The detector consists of a heated resistive element placed in a flow stream. The resistive element in this instrument is a microbead thermistor. Heat is conducted away from the thermistor when it is struck by gas molecules, which rebound

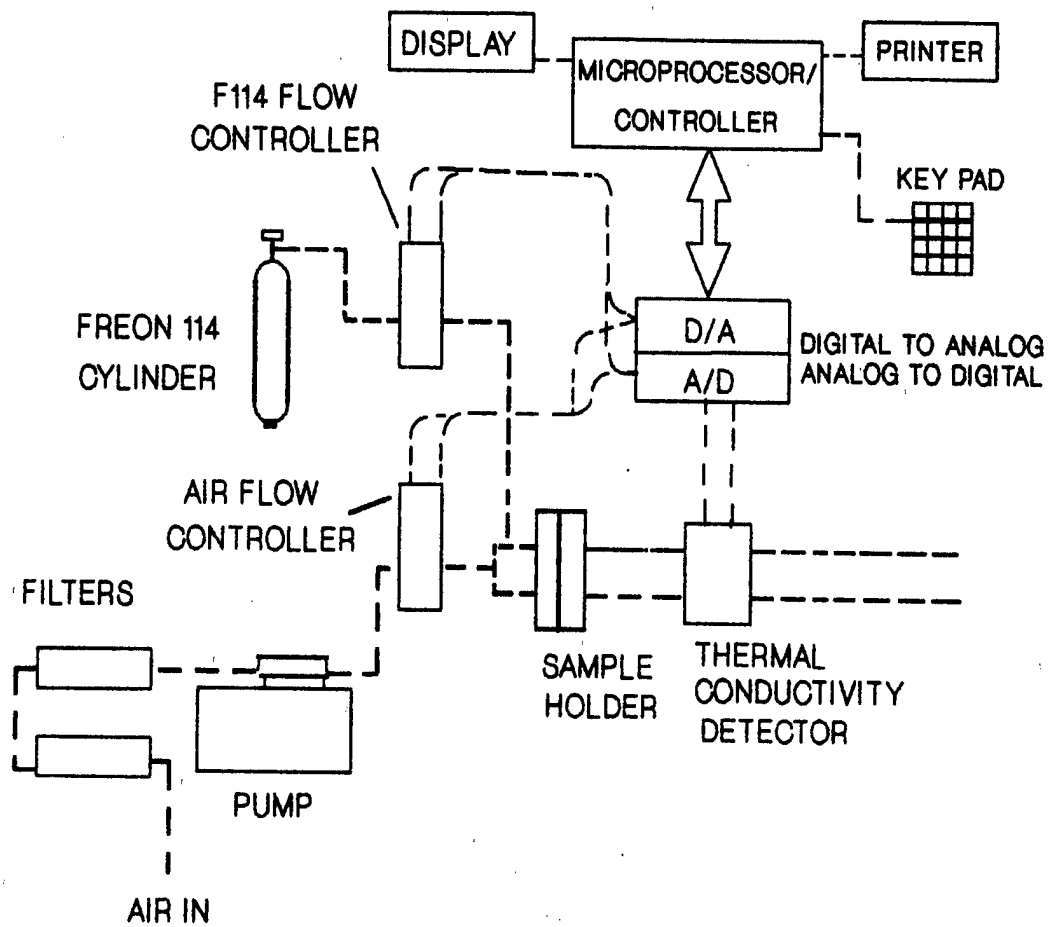

Figure 1. Schematic diagram of essential components of portable sorption tester.

with increased kinetic energy. The amount of heat loss is proportional to the number of molecules striking the thermistor in a given time.

Two matched thermistors are placed in separate flow channels and configured as a simple resistive bridge (Figure 2). With constant flow of carrier gas through each channel, a baseline or reference voltage will appear across the bridge. If one channel is maintained as a reference and challenge gas introduced into the other, the bridge will become unbalanced due to cooling of the thermistor in the sample stream when vapor breakthrough occurs. The resultant differential voltage is amplified and filtered before being sent to the analog to digital converter portion of the microprocessor controller.

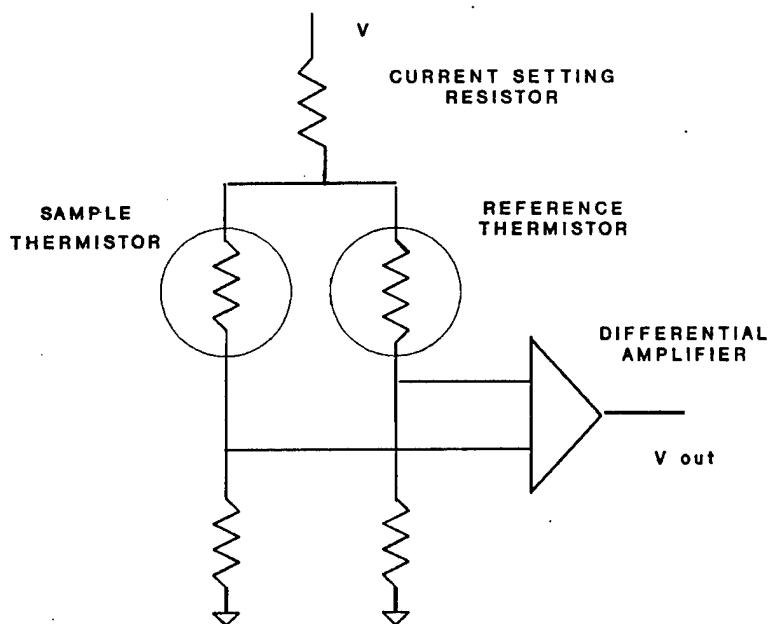

Figure 2. Thermal conductivity detector bridge.

The Phase I instrument (Figure 3) maintained a constant reference flow and switched the sample channel between purge and challenge. This resulted in long equilibration times when fabric was inserted into the sample holder as ambient air was introduced into this channel. Additionally, a rise in response followed by exponential decay was noted after fabric was inserted into the sample cup. This was believed due to desorption of lightly bound contaminants.

The Phase II instrument solves this problem by use of a two channel sample holder, which allows exposure of both detector channels to equal conditions. This results in minimum perturbation of the baseline when the sample holder is opened and fabric inserted, since the thermistors are in a differential configuration.

At a Freon 114 challenge of 150 milligrams per liter, the tests give about three minute breake time for dry Type III fabric. Samples that have been exposed to humid air are found to not sorb to full capacity, requiring that these samples be dried. Samples exposed to 100% RH atmosphere for 4 hours and 24 hours gave 17% and 70% lower Freon 114 sorption values, respectively (6). Although the overgarment is stored with drierite packets in an airtight bag, a programmed hot air flush cycle is added to the Tracer prototype for use in the field. All components are assembled into a transportable unit, which requires a 110V ac source.

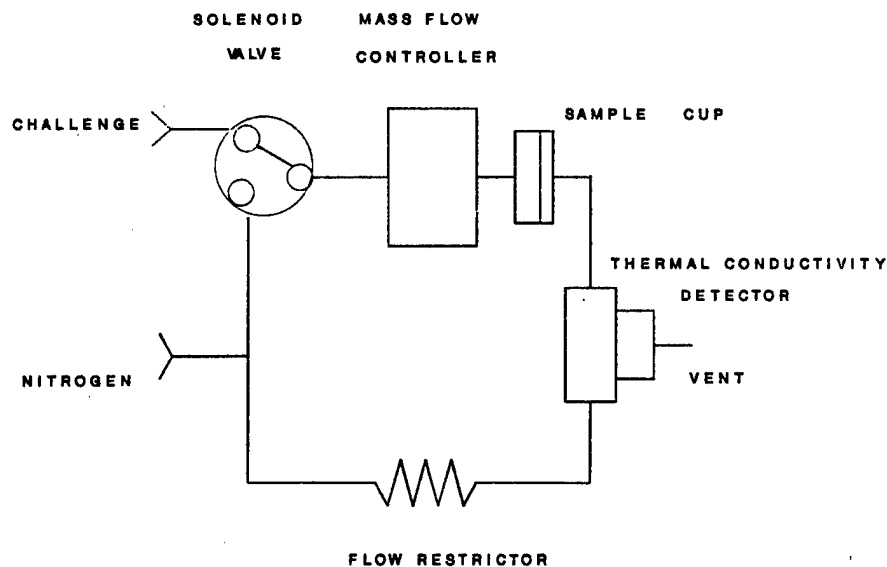

Figure 3. Phase I instrument configuration.

### 2.1.2 CHALLENGE SOURCE AND FLOW CONTROL

In the Phase II instrument an internal challenge source is obtained by use of scrubbed, dry air drawn in by a small diaphragm pump. The pump output is connected to a mass flow controller, which will maintain constant flow under all operational conditions and can be controlled by the microprocessor in response to operator input.

The output of the flow controller is split into two equal flow channels. Each of these channels passes through the sample holder and on to the detector. One of these channels is connected to the challenge source flow controller.

Phase I results indicated that for a one inch diameter sample area, a challenge rate of 5 milligrams per minute would allow characterization of average fabric in less than 5 minutes. As a result, halocarbon 114 was diluted to a concentration that would realize this challenge rate at a volume flow of 50 mL/min. Creating this mixture using a small cylinder of pure halocarbon 114 allows thousands of tests before replacement is required.

Several methods to supply the appropriate challenge rate from a small cylinder of pure halocarbon were investigated. The major difficulty was controlling a low-pressure gas at a flow rate of less than 1 mL/min. Permeation tubes were quickly eliminated as their temperature sensitivity and requirement for periodic gravimetric calibration rendered them unsuitable.

Pulsed sources were investigated next, with the belief that small bursts of pure gas could be mixed thoroughly to provide the required challenge rate. This was demonstrated using a multiport valve containing an internal volume of 100 microliters. This volume was injected into a carrier stream every 6 seconds, resulting in a net 1 mg/min flow. This approach was abandoned for two reasons: an unsuitably limited lifetime of the valve and the availability of a new, very low flow, mass flow controller from the same vendor supplying the air-flow controller.

The advent of this controller solved several control and measurement problems allowing the use of a pure halocarbon reservoir containing sufficient challenge for thousands of tests; however, substantial effort was expended in working with the vendor to solve some early production problems. A different model was developed and used in the second prototype tester.

### 2.1.3 MICROPROCESSOR CONTROLLER/DATA SYSTEM

All measurement, control, and operator interface aspects of the Phase II instrument are under control of a microprocessor. The microprocessor/controller is a single board computer compatible with the existing IBM PC architecture. A 12-bit data acquisition system board is connected to the address/data bus of the microprocessor. This board (DAS-16, Metrabyte Corp.) consists of sixteen 12-bit analog-to-digital converter inputs and two 12-bit digital-to-analog outputs.

The analog-to-digital (A/D) portion is used to measure temperature, detector output, and the output of each flow transducer. The digital-to-analog (D/A) portion is used to set the mass flow controllers to the desired operating point. Once set, the controllers are closed-loop devices. The flow signal is read by the microprocessor to confirm proper operation.

A two line, fluorescent alphanumeric display provides operational information and prompts the operator during the testing process. A 16-character keypad is used for operator input.

A thermal printer-plotter prints a summary of default operating conditions and system maintenance needs each time the instrument is powered-up. During a test run, test conditions, date, time, and other information are printed at the start of the run. The run is then plotted, stripchart fashion, during the run. When the desired breakthrough level has been reached, the run terminates and the total challenge amount and time are printed.

The response of the detector at various flow rates and temperatures was determined and correction factors established by regression of the data. In each case, the correlation coefficients were greater than 0.97. As a result of software algorithm corrections for both temperature and flow rate, runs are presented full scale regardless of these parameters. In the second prototype the detector temperature was maintained constant at 50 °C.

### 2.1.4 SOFTWARE

The heart of any microprocessor-based instrument is the software. Accordingly, development of the operational software for this device was one of the major challenges encountered in instrument development. The goal was a final turnkey product for use by minimally trained personnel. This desire led to numerous software revisions to make the operation as foolproof as possible.

All software was written in Turbo Pascal (Borland International) and compiled into a stand-alone program. This program and all supporting software (Autostart, for example) were programmed into Read Only Memory (ROM), in order that computer control would be established on power-up. Additionally, battery-backed Static Random Access Memory (SRAM) was included for storage of maintenance information, default operating parameters, and challenge remaining in the reservoir.

Some modifications to the instrument were anticipated by Natick. Specifically, a nondestructive sample holder of Natick design replaces the one provided with the instrument. In order to allow evaluation of operational parameters of total flow rate and challenge rate, more flexibility and operator control were incorporated in this software version than would probably be warranted in a device routinely used in the field.

For the second prototype, provision has been made for setting the internal clock/calendar. After several years the battery will be replaced by the local operator; the software required to reinitialize the system (as supplied by the memory board vendor) has been incorporated into the operational software.

In prototype I the penetration range available for choosing breaklevel was 20 to 70% of challenge concentration. Since Natick tests showed the value taken at 5% penetration corresponds well to the specification test and is also reproducible, the lower limit of the range that can be printed was set at this value for prototype II.

#### 2.1.5 THE NONDESTRUCTIVE CELL

A nondestructive cell was designed that allows insertion of an area of intact BDO garment for sorption tests. This cell avoided the need to use cut samples from the charcoal liner. Various cell seal designs were tried in aluminum mock cells with air inlet but no outlet. The seal was tested by timing the fall of water under air pressure in an arm of an enclosed tank, which was connected to the cell. Loads of 50 to 100 pound-inches could be stably applied on a cell situated under a fixed lever arm, by hanging weights from the end of the arm.

It was not possible to seal off an area of the double layer 7 oz/sq yd twill, 90 mil charcoal-impregnated polyurethane foam material with elastomer O-rings. Immediate leaking was always found with elastomer gaskets or O-rings between flat cell surfaces. A groove in one cell half to fit a protrusion in the other half could not be fabricated with the necessary close fit, and more complicated designs having offset grooves and protrusions with O-rings were not attempted.

The double layer material could be sealed by placing it between glass pipes and wrapping a Schott pipe connector around the joint. With the material pressed along one of the pipes, the metal banded connector with Teflon<sup>(R)</sup> and Hypalon<sup>(R)</sup> lining could be screwed as tight as necessary. Faster mounting is needed for routine, simple closure of a double sample cell. Seal was also obtained between mismatched standard taper glass connectors by means of hand pressure.

Tapered mock cells of aluminum could be simply tested by connecting to a balloon filled with air. The necessary closure force was applied by an Instron tensiometer in compression mode. The successful design, holding the balloon inflated for 30 minutes, was a mismatched taper, with an elastomer gasket against the foam side only. Initial problems with wrinkles were removed by making the cup depth shallow. A 4 cm diameter cell rim required 120 lb, and a 5 cm diameter cell rim required 200 lb. The mismatch of the tapers reduces the contact area to a narrow ring, increasing the compression. The seal results from compression of the foam. For a ring width greater than 1 mm the foam is not broken and the compression of the foam is reversible.

The final stainless steel double cell is shown in Figure 4. A tool jig is used to push a crossbar evenly onto two spring mounted shafts attached to the top cell halves, the bottom cell halves being supported on a steel plate. A band is machined out near the top rim of the bottom cells to hold a gasket, slightly inset. A matching aluminum mold was made for forming tapered gaskets. Silicone gaskets proved too limp and fragile; butyl gaskets performed well.

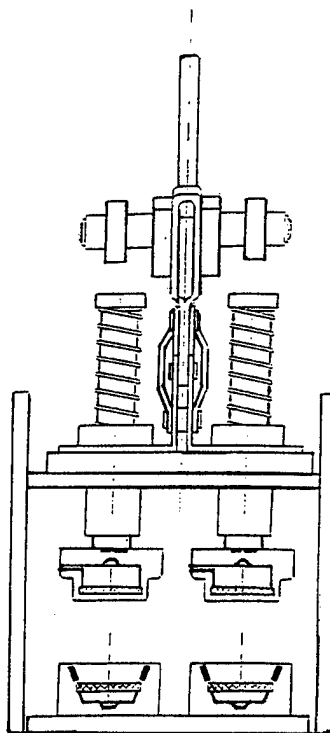

Figure 4. The double cell.

The assembled cell and portable sorption tester are shown in Figure 5.

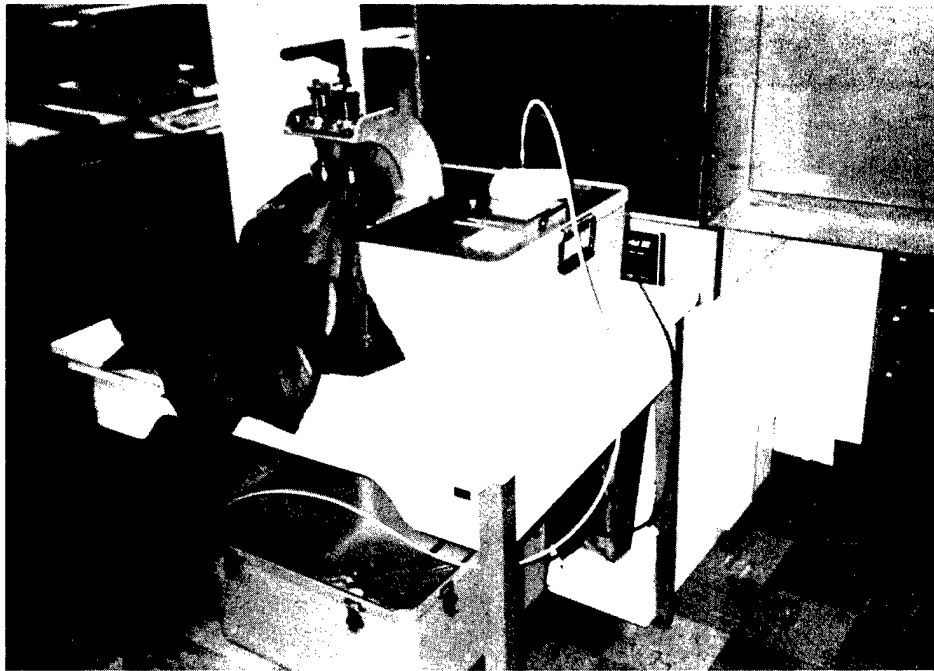

Figure 5. The nondestructive cell mounted in the portable tester.

### 3.0. OPERATION AND EXAMPLE RUNS

Operation of the Portable Sorption Tester is accomplished by pressing keys in response to visual prompts on the display panel. Complete operating and maintenance instructions may be found in Appendix A.

When the instrument is initially turned on, the printer will summarize the operational parameters retained from the previous operation. The two consumable items, halocarbon and activated carbon scrubber, are summarized so that replacement can be made prior to actual testing.

The preset (default) challenge flow and total flow values are then printed. These may be changed for the duration of power on through the normal operation menu and reset on next power-up. These values may also be changed to power-up defaults through the maintenance menu.

The following is an actual printout of the operational summary:

CURRENT OPERATIONAL PARAMETERS ARE:

DATE: SEPTMBR 11, 1991

TIME: 13:45:18

CHARCOAL FILTER HAS BEEN USED 62.5 HOURS (500 MAX)

195 GRAMS OF HALOCARBON 114 REMAIN IN CYLINDER

PRESET PARAMETERS ARE:

7.5 MG/MIN HALOCARBON CHALLENGE

50 ML/MIN AIR FLOW

Once in test mode, each test run is plotted and the results summarized. The printouts in Figures 6 and 7 are runs in the two prototype instruments on samples of chemical protective overgarment.

20.0% BREAKTHROUGH AT 3.7 MINUTES

TOTAL CHALLENGE: 27.7 MILLIGRAMS

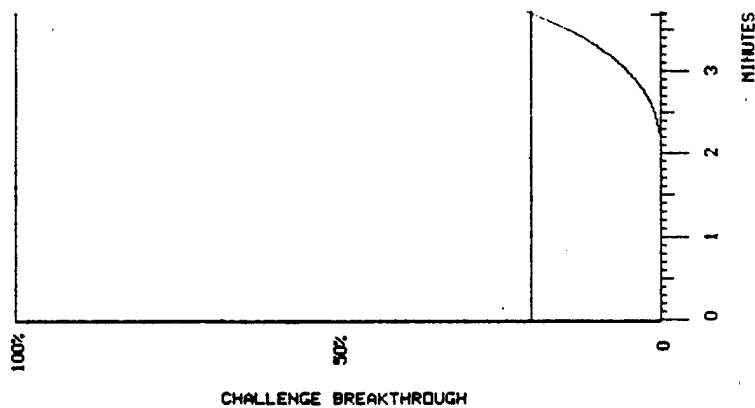

DATE: OCTOBER 5, 1990

TIME: 20:50:39 Z

SAMPLE ID: 11

OPERATOR ID: 1

CHALLENGE RATE: 7.5 MG/MIN

AIRFLOW: 50 ML/MIN

Figure 6. Typical test run in prototype I.

5 % BREAKTHROUGH AT 2.99 MINUTES

TOTAL CHALLENGE: 22.5 MILLIGRAMS

ACTUAL AIRFLOW: 49.7 ML/MIN

ACTUAL CHALLENGE RATE: 7.5 MG/MIN

DETECTOR TEMPERATURE: 47.3 C

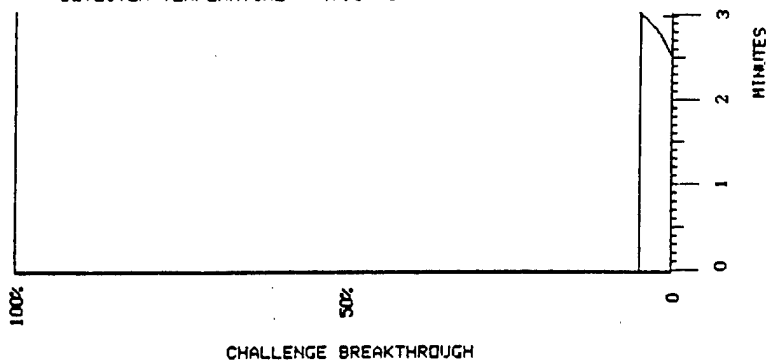

DATE: SEPTEMBER 11, 1991

TIME: 15:26:08

SAMPLE ID: 14

OPERATOR 1

CHALLENGE RATE: 7.5 MG/MIN

AIRFLOW: 50 ML/MIN

Figure 7. Typical test run in prototype II.

Challenge rates used in preliminary tests with Natick foam ranged between 1.5 and 3.0 mg/min. This was accomplished by adjusting the total flow between 100 mL/min and 200 mL/min. Comparisons of 50% breakthrough times indicated that at this setting breakthrough occurred at a constant total mass exposure.

The Phase II prototype instrument allows adjustment of both the total flow and challenge rate. The variability of breakthrough with respect to these flows was investigated as the challenge flows are higher and total flows lower than for the preliminary tests. Changing the challenge rate from 3 mg/min to 4 mg/min while maintaining total flow at 75 mL/min resulted in an increase for the total challenge at 70% breakthrough, from 27 to 28 mg, which is within experimental error.

When the challenge is held at 4 mg/min and the flow is reduced from 75 mL/min to 50 mL/min, the total challenge at 70% breakthrough increased from 28 mg to 33 mg. This apparent 18% increase in sorption was found in prototype I. Later, tests at Natick revealed that a similar increase in sorption was found for about one third of the foam samples from stockpiled overgarments, when they were retested under a cover fabric such as a piece of unimpregnated foam. Reproducibility of those samples that had not shown the usual invariability was then attained. The problem of channelling the challenge flow through foam is prevented in prototype II and in the Natick nondestructive cell by sintered steel diffuser plates.

#### 4.0 CORRELATION WITH STANDARD TEST

Reproducibility of Freon 114 tests carried out in the portable sorption tester with a nondestructive cell is shown in Figure 8. Twenty-five samples from stockpiled overgarments were run twice, after overnight regeneration in an airflow oven at 95 °C. Sorption per square centimeter at 5% penetration breaklevel was calculated by dividing cumulative challenge at breaktime by 9.0 square centimeter sample area. Unusually heavily loaded foams enhance the correlation; when the heaviest sample is excluded, correlation of two runs falls from  $R^2=.98$  to  $R^2=.95$ .

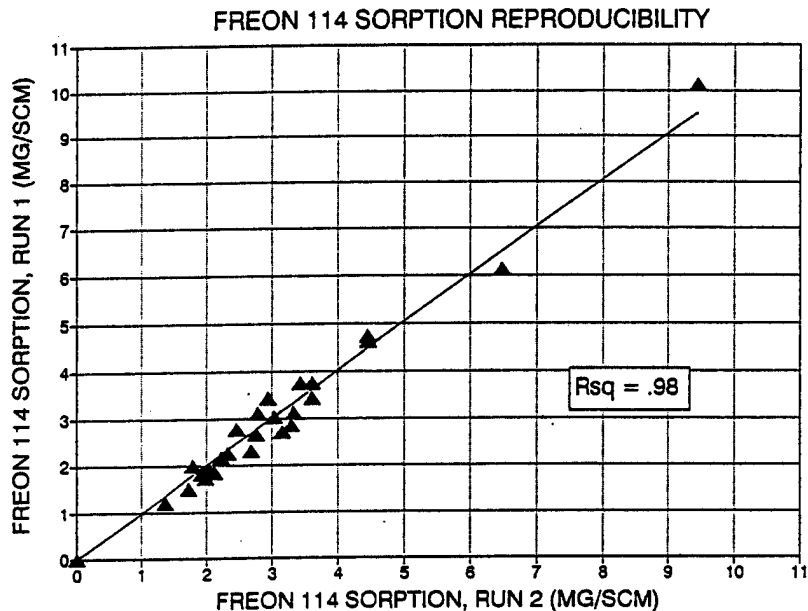

Figure 8. Reproducibility in the portable sorption tester.

To correlate the dynamic sorption capacities for Freon 114 measured with the portable sorption tester and for  $CCl_4$  with the standard Dawson apparatus, the same samples were used for each simulant. The average of two runs for each simulant on regenerated samples is plotted in Figure 9. The correlation fell from  $R^2=.94$  to .84 when the heaviest sample was excluded. Sorbed carbon tetrachloride can be completely removed by overnight treatment in the 95 °C air flow oven, giving reproducible Dawson values. Care was taken in sealing Dawson cups without using wax so that samples might be retested: a butt gasket was used around the five-inch sample, between upper and lower gaskets of slightly smaller I.D.

CORRELATION OF PORTABLE  
SORPTION TESTER WITH DAWSON APPARATUS

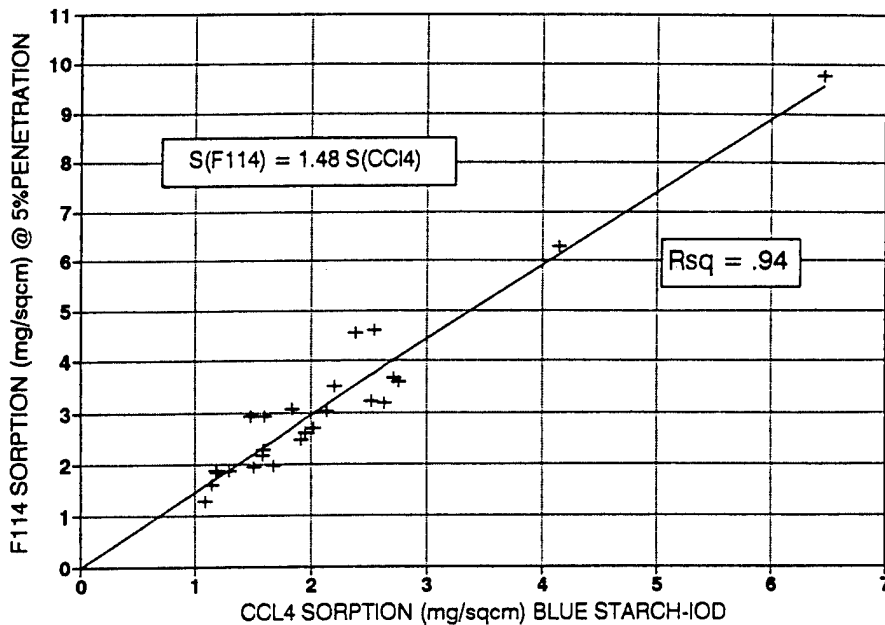

Figure 9. Correlation of dynamic sorption tests in the portable instrument and in the Dawson apparatus.

As shown in Fig. 9, Freon 114 sorption at breaktime is 1.48 times greater than  $CCl_4$  sorption. Both the higher relative pressure for Freon 114 challenge than  $CCl_4$  challenge (Table 1) and detection of  $CCl_4$  penetration at a lower concentration using starch-iodide detection of cumulative  $CCl_4$  penetration contribute to this result. The low challenge concentration used for nonvolatile HD also is a higher relative pressure challenge than for  $CCl_4$ .

TABLE 1. Comparison of Simulant and Challenge Vapor Conditions

Vapor	MW	Conc., mg/L	Temp., °C	Pressure, mm		P/P <sub>0</sub>
				Challenge, P	Saturated, P <sub>0</sub>	
CCl <sub>4</sub>	154	5	32	.618	154	.004
F114	171	150	25	16.3	1627	.010
HD	159	.020	32	.0024	.189	.013

There is a drop in Dawson  $\text{CCl}_4$  sorption after samples have been dried in an oven. A typical example is shown below (Fig. 10). Deliberate remoisturization of the samples recovers or enhances the original sorption values. There is no simple relation between moisture pickup and enhancement, and whether this phenomenon is a true sorption difference or is due to interference with detection by moisture is still being questioned. It has been observed by dynamic  $\text{CCl}_4$  tests with copper flame or static tests with  $\text{CCl}_4$  weight uptake detection methods.

### EFFECT OF DRYING SAMPLES ON DAWSON $\text{CCl}_4$ TESTS

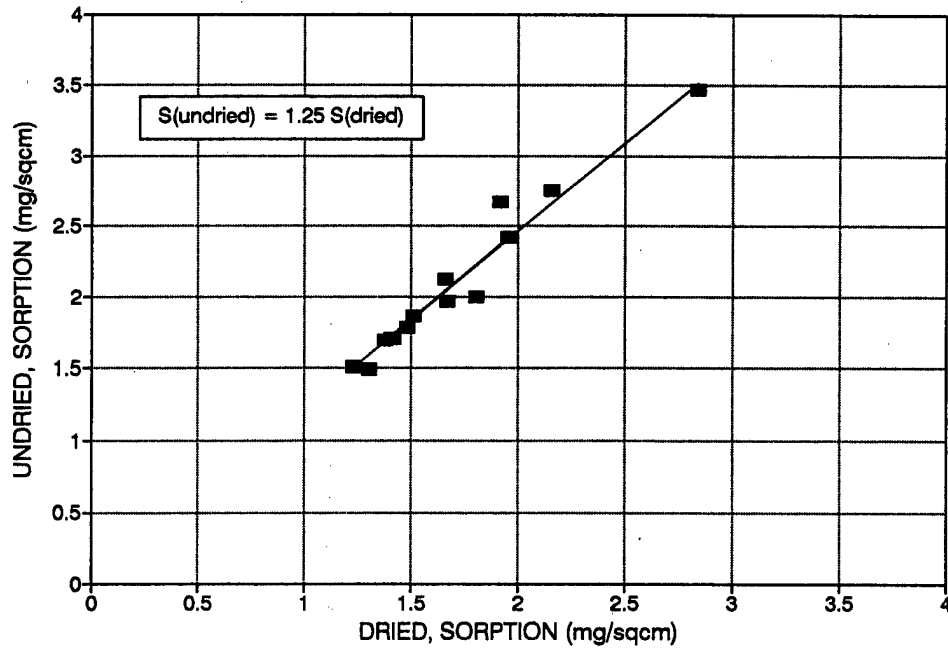

Figure 10. Heightened  $\text{CCl}_4$  sorption values are obtained on undried samples.

A comparison of Freon 114 tests (dry samples) with  $\text{CCl}_4$  tests on undried samples was done using neighbor pairs, i.e., cut from adjacent areas of a BDO jacket or trouser. In Fig. 11, each Freon 114 and  $\text{CCl}_4$  sorption value obtained was adjusted to the average weight of the neighbor pair in order to correlate the simulants. A linear relation of sorption vs. weight within a single roll of material is shown in Figure 12.

**SORPTION BY NEIGHBORING SAMPLES**  
 FREON 114: dry;  $\text{CCl}_4$ : undried

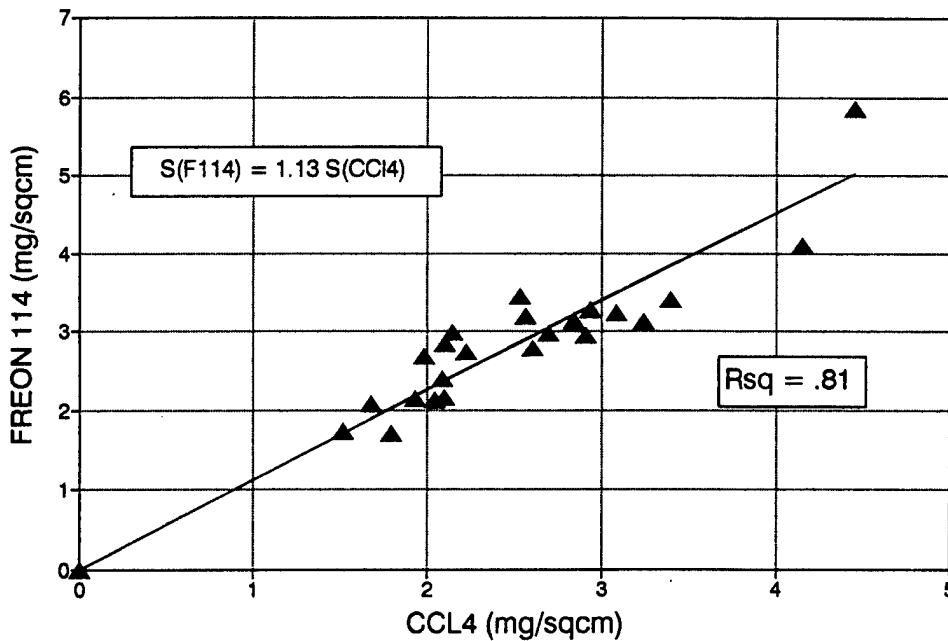

Figure 11. Correlation of sorption values obtained on partner samples (dried) with Freon 114 in the portable sorption tester, and (undried) with  $\text{CCl}_4$  in the Dawson apparatus.

PORTABLE SORPTION TESTER; FREON 114  
SAMPLES FROM THE SAME ROLL

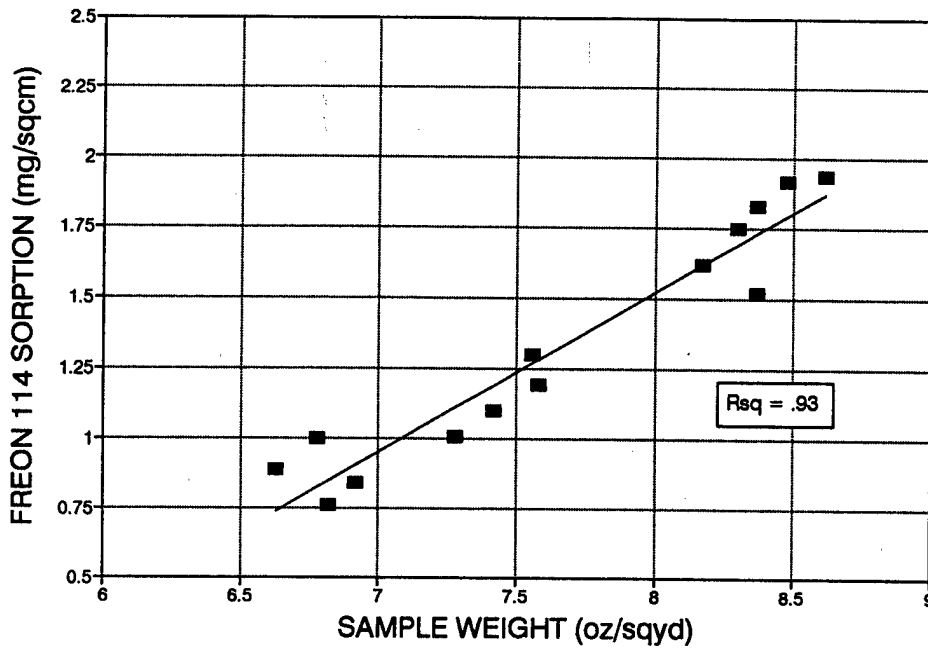

Figure 12. Linearity of sorption vs sample weight for samples taken from the same roll of material.

## 5.0. SUMMARY AND CONCLUSIONS

A turnkey instrument for determining sorption in chemical protective garment materials has been delivered by Tracer Technologies to Natick. Six problems were solved to achieve the goals of proof of validity, fast throughput, and portability:

Eliminate requirement for external carrier gas source.

Devise internal, low-pressure challenge vapor source.

Design double-stream system to measure penetration over background.

Prevent temperature-induced instability.

Automate measurement procedure to require minimum operator intervention and data interpretation.

Assemble into a transportable unit.

Evaluation of the portable sorption tester by Natick showed average test time is only three minutes, reproducibility is reliable, and correlation with the standard Dawson test method is satisfactory.

A heated air column sample drier and software for valve switching were installed by Industrial and Biomedical Sensors, Waltham, MA. The unit can thereby be used at ambient humidity without extra precautions to keep samples dry.

A sample holder was installed by Natick for nondestructive testing of intact chemical protective uniforms in the field. Cell leakage is eliminated by means of automatic application of sufficient force by a jig and is monitored by a meter at the flow outlet.

## REFERENCES

- (1) Paul Dawson and Marshall Gilchrist, Laboratory methods for evaluating the protection of permeable protective clothing against chemical agents, EATM311-3, Edgewood Arsenal, December 1967.
- (2) U.S. Department of Defense. Military Specification MIL-C-43858. Cloth, Laminated, Nylon Tricot Knit, Polyurethane Foam Laminate, Chemical Protective and Flame Resistant, Philadelphia PA, Standardization Document Order Desk, 700 Robbin Ave. Building 4D, January 1986.
- (3) Dawson and Gilchrist, op. cit., p.17.
- (4) Elizabeth Klemperer, Vapor simulant test methods for permeable sorptive fabrics, p. 145 in Proc. 3rd Int. Simulant Workshop, CRDEC-SP-011, November 1989.
- (5) Stephen Kerrin, Preliminary development of a portable device to determine sorption of chemical protective garments in the field, NATICK/TR-86/043L, December 1985 (AD B105 868L).
- (6) Elizabeth Klemperer, Vapor simulant test methods for permeable sorptive fabrics, p. 152 in Proc. 3rd Int. Simulant Workshop, CRDEC-SP-011, November 1989.

This document reports research undertaken at the US Army Natick Research, Development and Engineering Center and has been assigned No. NATICK/TR-92/042 in the series of reports approved for publication.

APPENDIX A  
OPERATIONS MANUAL

APPENDIX A  
OPERATIONS MANUAL

OPERATION AND MAINTENANCE

The Tracer Technologies Portable Sorption Tester is an advanced prototype device, which allows evaluation of protective properties of carbon-based fabric. A nondestructive sample holder and a sample drying attachment have been installed, which permit testing of CP overgarments in the field.

The instrument is a relatively portable, easily operated device, which uses a nonhazardous halocarbon gas as the challenge agent. Consumables are easily replaced in the field. The instrument is self-calibrating. Operator intervention consists of a minimal amount of keypad response to several prompts, and insertion of the fabric under test. Once a test is begun, its progress is plotted on a stripchart with all run parameters recorded.

Field service requirements are minimal, consisting of printer paper change, indicating desiccant change, air scrubber change every 500 hours of operation, and halocarbon reservoir change. The halocarbon reservoir contains sufficient challenge for several thousand tests at maximum challenge rate.

INITIAL SETUP

Remove the top lid. Place the instrument on a flat surface that can support the closing force you will apply on the sample holder.

The pump/filter module is stored in the top lid. Unfasten the spring-loaded slide bolts and place the pump within five feet of the main instrument. There are an air supply line and a power cable to connect the pump to the main unit. Uncap the drying tube inlet.

There is a power cord connected to the main unit. Electrical connection requires 110-120 volts at 60 hertz alternating current.

The instrument is shipped with the valve on the stainless steel halocarbon cylinder closed. The valve must also be closed if the halocarbon reservoir is to be changed, if the instrument is moved, or when the instrument is not being operated for several weeks.

## FRONT PANEL CONTROLS

Only two controls are present on the front panel. These are the power button and keypad. The keypad is a 16-button cluster containing the 0-9 digits, decimal point, hyphen or minus sign, backspace (left pointing arrow), ENTER, and a stop key ("S"). One key is not used. All keyboard responses are terminated by pressing the ENTER key, except for the stop key, which is active only during a run.

The POWER button will only turn the unit on. The microprocessor/controller will turn the device off after proper shutdown operations are accomplished. Do not disconnect the power until the shutdown procedure has proceeded to completion. Premature power disconnection may result in improper setting of flowmeters and valves, which can result in several hours of unstable operation on subsequent power-up.

## OPERATION

Close the sample holder (do not install fabric at this point) and press the POWER button. The pump will be heard to start and after a few seconds, a PLEASE STAND BY .. DETECTOR WARM-UP message will appear on the display, and will remain a few minutes while the detector temperature reaches 45 degrees Celsius.

After warm-up, the operational stores, consisting of the calculated grams of challenge remaining in the reservoir, and the number of hours the charcoal filter has been in operation, will print out. The printer will also list the default volume flow in mL/min and challenge rate in mg/min.

The operator will now be prompted MAINTENANCE RUN? (1=Y / 2=N). If the instrument is used daily, answer no; answer yes if the instrument has been idle for several days or if the halocarbon reservoir is replaced. In either case the valve on the halogen reservoir will have been closed and must be opened at this time. Open the valve by rotating it counter-clockwise several turns. Failure to fully open this valve could result in improper operation of the mass flow controller. Answering yes begins a dialogue for

SELF-TEST? which compares response of the mass flow controller to a set point; this should be done if the instrument has been idle for a few days.

CHANGE CHALLENGE CYLINDER? which allows replacement of the cylinder, and entering of the halocarbon weight into memory. Flush the system after a halocarbon cylinder change by making 2 or 3 runs at 90% threshold.

ESTABLISH RESPONSE? which determines the response scaling factor for the challenge rate and total flow rate; it also should be run after a few days' nonuse, and weekly with use. It is necessary after a halocarbon cylinder change. It may be done at any time between tests by responding 3 to ANOTHER TEST? rather than yes or no to bring up the maintenance menu.

RESET DEFAULTS? allows changing TOTAL FLOW and CHALLENGE FLOW, and enters the new values into memory.

CHANGE DATE/TIME? allows resetting these values

The display will instruct the operator

INSERT SAMPLE  
ENTER  
SAMPLE FLUSH, initiating 1 minute of hot air flush  
through the sample

The next message is

CHANGE PRESET FLOWS? this permits a temporary  
modification of the default parameters,  
remaining until change or until shut-  
down occurs.

Next, the following prompts are given

OPERATOR ID  
SAMPLE ID  
STOP THRESHOLD (5% - 90%)

After return is pressed the display will read

DETERMINING BASELINE

and testing goes on without further operator intervention. After  
about 30 seconds of baseline balance determination, the display  
changes to

TEST IN PROGRESS

and the printer starts plotting the run. When the predetermined  
breaklevel has been reached, accumulated challenge is printed out.  
The display then asks

ANOTHER RUN?

Answering yes returns to the beginning of the dialogue, and answering  
no begins the power shutdown procedure.

MOVING OR SHIPPING THE UNIT

Close the halocarbon cylinder valve. Halocarbon liquid must not  
enter the tubing connecting to the flow controller or it will be  
blown into the controller when the solenoid valve opens. Replacement  
of this low flow mass flow controller would require a major  
expenditure.

APPENDIX B  
THE SAMPLE DRYING SYSTEM



DISTRIBUTION LIST for PORTABLE SORPTION TESTER

One copy, unless otherwise indicated, is distributed to each address below.

Commander  
U.S. Army Chemical Research,  
Development and Engineering Center  
ATTN: SMCCR-DDE  
SMCCR-DDD  
SMCCR-DDP  
SMCCR-HV  
SMCCR-MSI  
SMCCR-MU  
SMCCR-MUP  
SMCCR-NB  
SMCCR-OPC  
SMCCR-OPF  
SMCCR-OPP  
SMCCR-PPC  
SMCCR-PPI  
SMCCR-PPP  
SMCCR-RS  
SMCCR-RCS  
SMCCR-RSL  
SMCCR-RSP  
SMCCR-RSP-A  
SMCCR-RSP-B  
SMCCR-RST  
SMCCR-SF  
SMCCR-SPS-T  
SMCCR-TDT (S. Lawhorne)  
SMCCR-RSC-O  
SMCCR-MUA  
SMCCR-TDE (Shandle)  
SMCCR-RSP-C  
SMCCR-RSP-P

Aberdeen Proving Ground, MD  
21010-5423

Commander  
U.S. Army Laboratory Command  
ATTN: AMSLC-TP  
2800 Powder Mill Road  
Adelphi, MD 20783-1145

Commandant  
U.S. Army Academy Health Sci  
ATTN: HSHA-CDH  
HSHA-CDS  
HSHA-IPM  
Fort Sam Houston, TX  
78234-6100

Commander  
US Army Natick Research,  
Development and Engineering Center  
ATTN: SATNC-T  
SATNC-TT  
SATNC-TE  
SATNC-AC  
SATNC-I  
SATNC-IC  
SATNC-IU  
SATNC-ICC  
SATNC-IT  
SATNC-ITF  
SATNC-ITP  
SATNC-MIL (7 copies)  
SATNC-TI  
SATNC-TN  
SATNC-TM  
SGRD-UE-Z  
SATNC-U  
SATNC-UE  
SATNC-UMP  
SATNC-US  
SATNC-IRT  
SATNC-Y  
SATNC-YM  
SATNC-YS  
SATNC-YBH  
SATNC-YBF  
SATNC-ZSB

Kansas St., Natick MA  
01760

Commander  
U.S. Army Materials Technology  
Laboratory  
ATTN: SLCMT-D (G. Bruggeman)  
SLCMT-EMP (W. Davidsohn)  
SLCMT-EMP (A. Wilde)  
SLCMT-MDF

Arsenal Street  
Watertown, MA  
02172

Director  
U.S. Army Concepts Analysis Agency  
ATTN: CSCA-RQL  
8120 Woodmont Ave.  
Bethesda, MD 20814-2797

Director  
U.S. Army Human Engineering Lab.  
ATTN: AMXHE-IS  
Aberdeen Proving Ground, MD  
21005-5001

Commander  
U.S. Army Test and Evaluation  
Command  
ATTN: AMSTE-CL  
AMSTE-TE-F  
AMSTE-TE-T  
Aberdeen Proving Ground, MD  
21005-5055

Director  
U.S. Army Research Office  
ATTN: AMXRO-CB  
AMXRO-GS  
PO Box 12211  
Research Triangle Park, NC  
27709-2211

Commander  
U.S. Army Armament, Munitions &  
Chemical Command  
ATTN: AMSMC-HO (A)  
AMSMC-QAC (A)  
AMSMC-QAE  
Aberdeen Proving Ground, MD  
21010-5423

Commander  
U.S. Army Medical Research  
Institute, Chem. Defense  
ATTN: SGRD-UV-L  
Aberdeen Proving Ground, MD  
21010-5423

Commander  
U.S. Army Scientific & Technical  
Info. Team, Europe  
ATTN: AMXMI-E-CO, Box 48  
APO New York 09079-4734

Director  
U.S. Army TRADOC Analysis Command  
ATTN: ATRC-WDB  
ATRC-WSL  
White Sands Missile Range, NM  
88002-5502

Director  
US Army Ballistic Research  
Laboratory  
ATTN: SLCBR-OD-ST(Tech Reports)  
SLCRB-SECAD (Tech Reports)  
Aberdeen Proving Ground, MD  
21005-5066

Commander  
US Army Science and Technology  
Center Far East Office  
ATTN: Medical/Chemical Officer  
APO San Francisco, CA 96328-5000

Commander  
US Army Troop Support Agency  
ATTN: DALO-TAF  
Fort Lee, VA 23801

Commander  
U.S. Army Foreign Science and  
Technology Center  
ATTN: AIAST-CW2  
220 Seventh Street, NE  
Charlottesville, VA 22901-5396

Toxicology Information Center, JH  
652  
National Research Council  
2101 Constitution Avenue, NW  
Andrews AFB, MD 20334-5000  
Washington, DC 20418

Commander  
U.S. Army Infantry Center  
ATTN: NBC Branch, Directorate of  
Plans & Training (Bldg. 2294)  
Fort Benning, GA 31905-5273

Commandant  
U.S. Army Infantry School  
ATTN: ATSH-CD-CS-CS  
Fort Benning, GA 31905-5400

Commandant  
U.S. Army Infantry School  
ATTN: ATSH-B, NBC Branch  
Fort Benning, GA  
31905-5410

Commandant  
U.S. Army Infantry School  
ATTN: ATSH-CD-MLS-C  
Fort Benning, GA  
31905-5800

Director  
U.S. Army Materiel Command Field  
Safety Activity  
ATTN: AMXOS-SE  
Charlestown, IN  
47111-9669

Commandant  
U.S. Army Chemical School  
ATTN: ATZN-CM  
ATZN-CM-CC  
ATZN-CM-CS (Deputy MLSO)  
ATZN-CM-CT  
ATZN-CM-MLB  
ATZN-CM-NC  
Fort McClellan, AL 36205-5000

Commander  
Naval Weapons Center  
ATTN: Code 3893  
China Lake, CA 93555

Commander  
U.S. Army Chemical Activity  
ATTN: APCA-SPO  
APO San Francisco  
96305-0008

Commander  
U.S. Army Depot Systems Command  
ATTN: AMSDS-QA-V  
AMSDS-RE-S  
AMSDS-SF  
Chambersburg, PA 17201-4170

Commander  
U.S. Army TRADOC Independent  
Evaluation Directorate  
ATTN: ATZL-TIE-C  
Fort Leavenworth, KS 66027-5130

Commander  
Naval Air Development Center  
ATTN: Code 60332  
Warminster, PA  
18974-5000

Commander  
Lexington Blue Grass Army Depot  
U.S. Army Academy Health Sci.  
ATTN: SDSLB-AMP-C  
Richmond, KY 40475-5070

Commandant  
US Army Academy of Health Science  
ATTN: HSHA-CDH  
HSHA-CDS  
HSHA-IPM  
Fort Sam Houston, TX  
78234-6100

Commander  
U.S. Army Dugway Proving Ground  
ATTN: STEDP-SD  
STEDP-SD-TA-F (Technical  
Library)  
Dugway, UT  
84022-6630

Commander  
U.S. Army Nuclear and Chemical  
Agency  
ATTN: MONA-CM  
7500 Backlick Road, Bldg 2073  
Springfield, VA  
22150-3198

Commander  
U.S. Army Materiel Command  
ATTN: AMCCN  
AMCSF-C  
AMCLD  
5001 Eisenhower Avenue  
Alexandria, VA  
22333-0001

Commander  
U.S. Army Training and Doctrine  
Command  
ATTN: ATCD-N  
Fort Monroe, VA  
23651-5000

Director  
Air Force Wright Aeronautical Lab.  
ATTN: FIEEC  
Wright-Patterson AFB, OH  
45433

Commander  
Aeronautical Systems Division  
Life Support Program Office  
ATTN: ASD/AESD  
ASD/AEEE  
ASD/AEEE  
ASD/AEEE  
Wright-Patterson AFB, OH  
45433

Commander, U.S. Army  
Logistics Center  
ATTN: ATCL-MGF  
Fort Lee, Va 23801-6000

Chemical-Biological Information  
Analysis Center  
Battelle Edgewood Operations  
2113 Emmorton Park Road, Suite 200  
Edgewood, MD 21040

Commander, U.S. Air Force, ATTN:  
AL/CFT (Bomuloski), Brooks AFB,  
Texas 78235-5301

Director, U.S. Army Material  
Systems Analysis Agency, ATTN:  
AMXSU-CR (Carothers); Aberdeen  
Proving Ground, MD 21005-5071

Commander, U.S. Army Dugway  
Proving Ground, ATTN: STEDP-MT,  
Dugway, UT 84022-5000

Commander, U.S. Army  
Environmental Hygiene Agency,  
ATTN: HSHB-MO-T (Nelson), Aberdeen  
Proving Ground, MD 21010

Commander, Marine Corps Systems  
Command, ATTN: (Guglielmo)  
Quantico, Va 22134-5080

Commander, Naval Surface  
Warfare Center, ATTN: Engels, H-31  
Dahlgren, VA 22448-5000

Office of The Surgeon General  
(OTSG), HQ DA ATTN: SGPS-PSP 5109  
Leesburg Pike, Falls Church, VA  
22041-3258

PM Soldier, ATTN: AMCPM-CIE  
(Gidley), 14050 Dawson Beach Rd.,  
Woodbridge, VA 22191-1419

Commander, U.S. Army Test and  
Evaluation Command, Aberdeen  
Proving Ground, MD 21005-5055  
AMSTE-TA-G (Kocher)

Commander, Operational  
Evaluation Command, ATTN: ESC-A,  
Alexandria, VA 22041-3258