

**US Army Corps
of Engineers®**
Engineer Research and
Development Center

Bluestone Lake Dam, West Virginia, Rating Curve and Overtopping Study

Billy D. Fuller

March 2002

20020405 040

ERDC/CHL TR-02-2
March 2002

Bluestone Lake Dam, West Virginia, Rating Curve and Overtopping Study

by Billy D. Fuller

Coastal and Hydraulics Laboratory
U.S. Army Engineer Research and Development Center
3909 Halls Ferry Road
Vicksburg, MS 39180-6199

Final report

Approved for public release; distribution is unlimited

Prepared for U.S. Army Engineer District, Huntington
Huntington, WV 25701-2070

Contents

Preface	v
Conversion Factors, Non-SI to SI Units of Measurement	vi
1—Introduction	1
Prototype	1
Purpose of Model Study	1
2—Physical Model	3
Description	3
Interpretation of Model Results	3
3—Experiments	5
Phase A	5
Rating curves	5
Spillway and stilling basin pressures	7
Abutment erosion potential	8
Training wall height	9
Dynamic Loading	9
Spill gate and spillway pier	9
Dynamic pressures	10
Phase B (Overtopping)	10
Rating curve	10
Abutment erosion potential	10
Overtopping pressures at intake	10
4—Summary	11
Rating Curves	11
Spillway Pressures	11
Abutment Erosion	12
Pressures	12
Figures 1-41	
Photos 1-4	

Appendix A: Piezometric Pressure Data, Stilling Basin A1
Appendix B: Pressure Cell Data, Stilling Basin B1
Appendix C: Pressure Cell Data, Spill Gate C1
Appendix D: Pressure Cell Data, Spillway Pier D1
Appendix E: Pressure Cell Data, Overtopping E1
Appendix F: Nappe Profile for Probable Maximum Flood F1
SF 298

Preface

The study was authorized by the Office, Chief of Engineers, U.S. Army, at the request of the U.S. Army Engineer District, Huntington. Points of contact for the Huntington District were Messrs. Coy Miller, Dave Margo, and Ken Halstead.

The work was conducted during the period April 1999 to December 2000 in the Coastal and Hydraulics Laboratory (CHL) of the U.S. Army Engineer Research and Development Center (ERDC). The study was under the direction of Mr. Thomas W. Richardson, Acting Director, CHL, and under the general supervision of Mr. James R. Leech, Chief of the Spillways and Channels Branch. The principal investigator for the model study was Mr. Billy D. Fuller, assisted by Messrs. Kevin Pigg, Bill Katzenmeyer, John Williams, and Douglas White all of CHL, and Mr. Ed Johnson of Mevatec Corp. The model was constructed by personnel of the Department of Public Works under the direction of Mr. Cecil Dillon. Messrs. Fuller, Pigg, and Katzenmeyer prepared this report.

At the time of publication of this report, Dr. James R. Houston was Director of ERDC, and COL John W. Morris III, EN, was Commander and Executive Director.

The contents of this report are not to be used for advertising, publication, or promotional purposes. Citation of trade names does not constitute an official endorsement or approval of the use of such commercial products.

Conversion Factors, Non-SI to SI Units of Measurement

Non-SI units of measurement used in this report can be converted to SI units as follows:

· Multiply	· By	· To Obtain
feet	0.3048	meters
cubic feet per second	0.02831685	cubic meters per second
degrees (angle)	0.01745329	radians
pounds (force) per square inch	0.006894757	megapascals

1 Introduction

Prototype

The Bluestone Lake Dam was constructed as a multipurpose concrete gravity dam and is located on the New River, near Hinton, WV (Figure 1). Completed in 1949, the structure consists of a 21-bay spillway, nonoverflow and intake sections (Figure 2). The spillway is 790 ft long with a crest elevation of 1,490¹ and contains 16 sluices to pass low pool flows. A stilling weir with crest elevation of 1,392 is located just downstream of the spillway to maintain tailwater for energy dissipation. The intake section contains six penstocks for possible future hydropower generation. The top elevation of the dam is 1,535.

As a result of the new Probable Maximum Flood (PMF) criteria developed by the National Weather Service, the dam must be modified to pass a discharge higher than the original design. In an effort to meet the PMF criteria, the top elevation of the dam will be raised, via a parapet wall, to el 1,549. A higher head will be induced on the dam, which will increase spillway and sluice discharge to a level over their original design capacities. The penstocks will be used to further increase total discharge capacity of the dam during extremely high discharge events.

Purpose of Model Study

The purpose of this model study is to verify the discharge capacity of the Bluestone Lake Dam after it is modified to provide flood control for the new PMF. The modifications that will affect the hydraulics of the structure are adding a 14-ft-high parapet wall (head increase on the dam) and using the penstocks for emergency discharge.

Other areas to be investigated are: pressures along the spillway and in the stilling basin, erosion potential of the east abutment due to penstock

¹ Unless stated otherwise, all elevations (el) cited herein are in feet as referred to in the National Geodetic Vertical Datum (NGVD) of 1929. To convert feet to meters, multiply by 0.3048.

discharge, determination of the necessary training wall height increase to contain the increased spill discharge, and to investigate the option of overtopping the intake section of the structure to increase discharge capacity.

2 Physical Model

Description

A flume was designed to accommodate reproduction of the structures, a 2,200-ft reach of the tailrace and a 1,000-ft reach of the upper pool topography at an undistorted linear 1:65 scale. All pertinent topography was reproduced with molded cement mortar over sand. The structures were constructed of sheet metal, acrylic, and wood. The model layout is shown in Figure 3.

The discharges were established using Data Industrial flow meters. These meters were calibrated using the U.S. Army Engineer Research and Development Center (ERDC) calibration flume. Water-surface elevations were measured with point gages. The point gages were located 800 ft upstream of the dam axis and 1,000 ft downstream of the dam axis. The tailwater was maintained with an adjustable tailgate.

Pressures were measured using piezometer taps and a stilling well system. Piezometer taps were located on 10-ft (prototype) intervals along the center of spillbay 5 and extended through the stilling basin. The stilling basin locations were duplicated laterally three bays over (downstream of spillbay 8). These locations are shown in Figure 4. Pressure cells were used for time-history recordings in six locations in the stilling basin. Pressure cells locations were determined from the piezometric pressure variances.

Velocities were measured with Acoustic Doppler Velocity (ADV) probes, pitot tubes, and a video tracking system (VTS). The VTS and dye streaks were used in documenting surface current patterns.

Interpretation of Model Results

The accepted equations of hydraulic similitude, based on the Froudian criteria, were used to express the mathematical relations between the dimensions and hydraulic quantities of the model and the prototype. The

general relations expressed in terms of the model's scale or length ratio, L_r , are expressed in Table 1.

Table 1
Scale Relations

Dimension	Ratio	Scale Relation
Length	L_r	1:65
Area	$A_r = L_r^2$	1:4,225
Velocity	$V_r = L_r^{1/2}$	1:8.062
Discharge	$Q_r = L_r^{5/2}$	1:34,063
Time	$T_r = L_r^{1/2}$	1:8.062
Force	$F_r = L_r^3$	1:274,625
Frequency	$f_r = 1/L_r^{1/2}$	1:0.124

Measurements of each of the dimensions or variables can be transferred qualitatively from model to prototype equivalents by means of the scale relations (Table 1). All model data are presented in terms of prototype equivalents.

3 Experiments

Phase A

Rating curves

Spillway and sluice rating curve. Flow through the spillway of the Bluestone Lake Dam is controlled by a series of slide gates. Due to the original design of the gate machinery, the fully open gates provide 33-ft above the spillway crest. The higher pool elevation required to pass the new PMF will cause the spillway nappe to contact the bottom of the gate. When this occurs, the control of discharge through the spillway transitions from free overflow to an orifice flow. Thus, an extension of the spillway discharge rating curve cannot be accomplished by analytical methods.

In order to develop an extension of the discharge rating curve for the modified Bluestone Dam, the model response had to be verified. This verification consisted of validating the spillway and sluice discharge capabilities individually.

The model spillway was verified using data from the design model (Carnegie 1937)¹. The original study produced a discharge rating curve for flows up to a 388.5 kcfs spillway discharge. Figure 5 shows the verification rating curve for the spillway.

Because geometric scaling of trash racks at a 1:65 scale will not accurately reproduce the head loss, the sluices were constructed without trash racks and calibrated in place. Calibration of sluice flow required installing expanded metal screens at the inlet of the sluices to simulate the appropriate amount of head loss. Figure 6 shows the verification rating curve for all 16 sluices.

Once the rating curves for the spillway and sluices were verified, the rating curve was extended for flows to a maximum pool elevation of 1,546.8

¹ Carnegie Institute of Technology. (1937). "Laboratory test on hydraulic models of Bluestone Dam, New River, Hinton, WV," Hydraulic Laboratory, Carnegie Institute of Technology, Pittsburgh, PA.

(the original maximum pool elevation was 1,520.0). The model data is presented in Table 2. The extended rating curve is presented in Figure 7.

Table 2
Spillway and Sluice Rating Curve

Discharge, kcfs	Pool Elevation, NGVD	Comment
38.0	1,430.19	No spillway gates
49.0	1,452.55	
57.9	1,475.89	
79.5	1,493.44	
88.1	1,494.61	
192.4	1,504.88	
193.8	1,504.68	
284.3	1,510.68	
354.6	1,515.21	
355.4	1,515.08	
450.4	1,520.15	
450.8	1,520.15	
557.0	1,524.84	
563.7	1,525.61	
672.5	1,528.41	
728.9	1,530.75	
730.9	1,531.21	
997.6	1,542.90	
1,008.1	1,542.90	
1,100.3	1,546.80	
1,104.2	1,546.80	
849.7	1,537.83	33-ft gate opening
855.1	1,538.94	
856.1	1,538.42	
891.7	1,546.80	
898.7	1,546.80	

Spillway, sluice, and penstock rating curve. The penstocks were originally constructed for power generation. However, interest in hydro-power declined and the powerhouse was never constructed. Subsequently, the recent dam safety assurance studies determined that it would be feasible to use the penstocks to accommodate passage of the PMF. Therefore, physical modeling was determined to be the best means for developing a reliable discharge rating. Table 3 and Figure 8 present flow conditions used and resulting rating curve for passage of flow through the spillbays, sluices, and penstocks.

Table 3
Spillway, Sluice, and Penstock Rating Curve

Discharge, kcfs	Pool el, NGVD	Tailwater el	Comment
88.3	1,452.8	1,379	With air vents open
109.4	1,474.0	1,380	
602.5	1,520.0	1,398	
602.8	1,520.0	1,398	
963.6	1,535.0	1,408	
963.8	1,535.0	1,408	
1,040.8	1,546.8	1,410	
1,060.4	1,546.8	1,414	
88.3	1,448.6	1,379	With air vents closed
109.4	1,470.8	1,380	
604.5	1,519.0	1,398	
983.9	1,535.8	1,408	
1,049.1	1,546.8	1,414	

Figure 8 shows information for vented and nonvented penstock flow. No significant change in discharge capacity resulted from penstock ventilation.

Spillway and stilling basin pressures

Spillway pressures. The ogee shape of the spillway is designed to reduce the probability of cavitation by maintaining pressures along the spillway face of a negative 15 ft of water or greater (HQUSACE 1990).¹ An increased head on the spillway will reduce the pressures on its face, thus increasing the cavitation potential. Pressures along the spillway face were measured for discharges up to 890,000 cfs (spillway and sluice discharge, at pool el 1,546.8). These pressures are presented in Figures 9 and 10.

Stilling basin pressures. The pressures in the stilling basin were measured using piezometer taps and with pressure cells (Kulite 1994).² The piezometer taps are in two arrays, one along the center line of spillbay 5 and the other along the center line of spillbay 8. The piezometer taps were located on 10-ft intervals, beginning just downstream of the baffle blocks (175 ft from the axis of the dam) to just upstream of the stilling weir (345 ft from the axis of the dam). The flow conditions used for the stilling basin

¹ Headquarters, U.S. Army Corps of Engineers. (1990). "Hydraulic design of spillways." EM 1110-2-1603, January 1990.

² Kulite Semiconductor Products, Inc. (1994). "Pressure transducers, Model XTM-190." Kulite Product Data Sheet. Leonia, NJ.

evaluation are shown below in Table 4. These data are presented in tabular and graphical form in Appendix A.

Pressure cells were used to record time-history pressures at three locations in each array. These locations were determined from the piezometric data. The locations showing the highest variance in piezometric pressure were chosen for pressure cell locations. They were locations 2, 11, and 18. The pressure cell data are presented in Figures 11-24. The model data are in Appendix B.

Table 4
Stilling Basin Evaluation Flows

Condition Number ¹	Discharge, kcfs ²	Pool el, NGVD	Tailwater el
1	28.0	1,415	1,374
2	49.5	1,455	1,376
3	87.0	1,480	1,379
4	193.0	1,505	1,384
5	355.0	1,515	1,390
6	450.0	1,520	1,394
7	560.0	1,525	1,397
8	730.0	1,530	1,402
9	855.0	1,539	1,410
10	895.0	1,547	1,414

¹ Conditions 1, 2, and 3 do not have spillway discharge (sluices only).

² Total river discharge. All spillways and sluices are in operation.

Abutment erosion potential

Erosion of the east abutment is a concern during events with penstock release. The penstock discharge forms an eddy near the toe of the east abutment. With low tailwater, the flow is not in contact with the abutment, but at high tailwaters (those likely to be present during flows approaching the PMF) the eddy is a potential cause of erosion. The velocity and size of the eddy was documented using a video tracking system. The flow conditions used for this evaluation were a maximum pool (el 1,546.8, 1,050 kcfs) and a high tailwater (el 1,414.0). The data for this condition are presented in Figure 25.

In an effort to reduce the velocities in the eddy, several outlet deflector configurations were investigated. A deflector was attached to the outlet of each penstock. The six-penstock outlet deflectors had the same orientation during a test (i.e., all deflectors were affixed to the outlets in the same direction and had the same amount of deflection). There were six tests conducted on the deflectors. The deflector orientations were 15 and 30-deg

deflections into and away from the channel and 15- and 30-deg deflections up. These data are presented in Figures 26-31.

Training wall height

The height of the stilling basin training walls were evaluated for a range of river flows up to the PMF. Training wall extensions were installed in the model as seen in Photos 1 and 2. The resulting necessary wall heights for infrequent overtopping are presented in Table 5.

**Table 5
Training Wall Height**

Discharge, kcfs	Tailwater el, NGVD	East Wall Height, NGVD	West Wall Height, NGVD	Comment
193.4	1,385.0	—	—	No extension needed
357.6	1,392.0	1,420	1,420	
456.9	1,398.0	1,440	1,440	
567.1	1,398.5	1,450	1,450	Estimate, overtopped extended walls
733.4	1,406.0	1,430	1,430	No jump in basin, spill discharge impacts the stilling weir
858.2	1,412.5	1,435	1,435	No jump in basin, spill discharge impacts the stilling weir
917.5	1,414.0	1,435	1,435	No jump in basin, spill discharge impacts the stilling weir

After onsite observation with district personnel, it was determined that a more frequent overtopping would be acceptable. The training wall heights were modified as shown in Photos 3 and 4. The final training wall dimensions are shown in Figure 32.

Dynamic Loading

Spill gate and spillway pier

The additional head on the spill gates, resulting from changing the maximum upper pool, will increase the loads on the supporting piers. Because some of the pier support structure (Figure 33) will be inundated during the PMF, it was uncertain if the dynamic loading would be higher than the static loading. Pressure cells (Druck 2000)¹ were installed in a spill gate and a pier to measure the dynamic pressures (Figures 33 and 34).

¹ Druck, Inc. (2000). "Pressure transducers, Type PDCR 800 Series," Druck Product Data Sheet. New Fairfield, CT.

Dynamic pressures

These pressures are intended to provide information to design engineers that will assist in the analysis of the structural stability of the existing spillway piers and gates. The data summary sheets and waveforms are in Appendix C.

Phase B (Overtopping)

Rating curve

Phase B of the model study was to investigate the effects of overtopping the intake section of the dam (Figure 35). The rating curve, developed for Phase A of this study, was extended to include data for the overtopped intake section. Figure 36 shows the extended rating curve with the intake overtopping data.

Abutment erosion potential

The flow conditions near the east abutment were again investigated. The discharge used was the same as used for Phase A of this study (upper pool el 1,546.8 and lower pool el 1,414.0). Overtopping of the intake section did not significantly change the eddy size or intensity near the east abutment.

Phase A experiments indicated that installation of penstock deflectors was not an effective means of reducing the eddy. Therefore, a training wall was investigated to determine a minimum wall length and height necessary to reduce velocities near the east abutment. Figures 37-40 show data for wall lengths of 100 to 200 ft. The wall height should be equal to the highest expected tailwater elevation.

Overtopping pressures at intake

Pressures resulting from overtopping were a concern at two locations on the intake structure. They were at the toe of the structure where overtopping flow impacts and at the top of the structure, a possible low-pressure zone (Figure 41).

Pressure cells (Druck)¹ were installed at these two locations to provide time-history records of pressure. Pressures were recorded for two flow conditions, upper pool el 1,546.8 and 1,542.0 with lower pool el 1,414.0 and 1,409.0 respectively. These data are included in Appendix E.

¹ Druck, Inc. (2000). "Pressure transducers, Type PDCR 800 Series." Druck Product Data Sheet, New Fairfield, CT.

4 Summary

Rating Curves

The additional head in the upper pool, provided by the 14-ft-high parapet wall, increased the total discharge that the dam is required to pass. The original upper pool elevation of 1,520.0 was initially increased to 1,546.8. The corresponding increase in discharge for combined spillway and sluice operation was approximately 100 percent with the spill gates in the full-open position of 33-ft (450,000 cfs to 900,000 cfs). For discharges that were combined spillway, sluice, and penstock operations, the increase was approximately 75 percent (600,000 cfs to 1,050,000 cfs).

By utilizing the penstocks for emergency release, the new PMF (approximately 950,000 cfs) could be passed with the parapet wall installed and reduced in height to produce a maximum pool el of 1,542.0.

The second phase (Phase B) of this study investigated the overtopping of the intake section of the structure. This allowed river flow passage through the spillway, sluices, penstocks and the overtopping flow. The capacity was increase of approximately 1,100,000 cfs at upper pool elevation of 1,546.8.

Spillway Pressures

The cavitation safety curves in EM 1110-2-1603, "Hydraulic design of spillways," indicate the upper limit of acceptable low pressures on the spillway face is -15 ft. This limit was reached at a discharge of approximately 900,000 cfs (spillway and sluice discharge only). If emergency penstock release is utilized during the PMF, the spillway and sluice discharge will be reduced to approximately 850,000 cfs. The corresponding spillway face pressure is approximately -14 ft. While this is on the edge of the limit, it is within design criteria.

Abutment Erosion

During discharges that require penstock release, an eddy is formed adjacent to the east dam abutment. The velocities in the eddy approach 30 fps next to the bank. This velocity magnitude can cause severe erosion and reduce the structural integrity of the dam. In an effort to reduce the velocities in this area, several penstock deflector configurations were investigated. These deflectors were 15 and 30 deg into and away from the bank and 15 and 30 deg upward. None of these configurations improved flow conditions.

A vertical wall was placed on the east abutment side of the intake structure. The wall length was varied from 100 to 200 ft. The minimum length required to reduce velocities to a manageable level (less than 20 fps) was 175 ft. The wall height should be equal to the highest expected tailwater elevation.

Pressures

Several pressures were recorded throughout this study. These measurements are intended to aid in the design of anchoring systems and structural component design verification. They are to be used as needed by the design engineers. These data are presented in Appendices B-E.

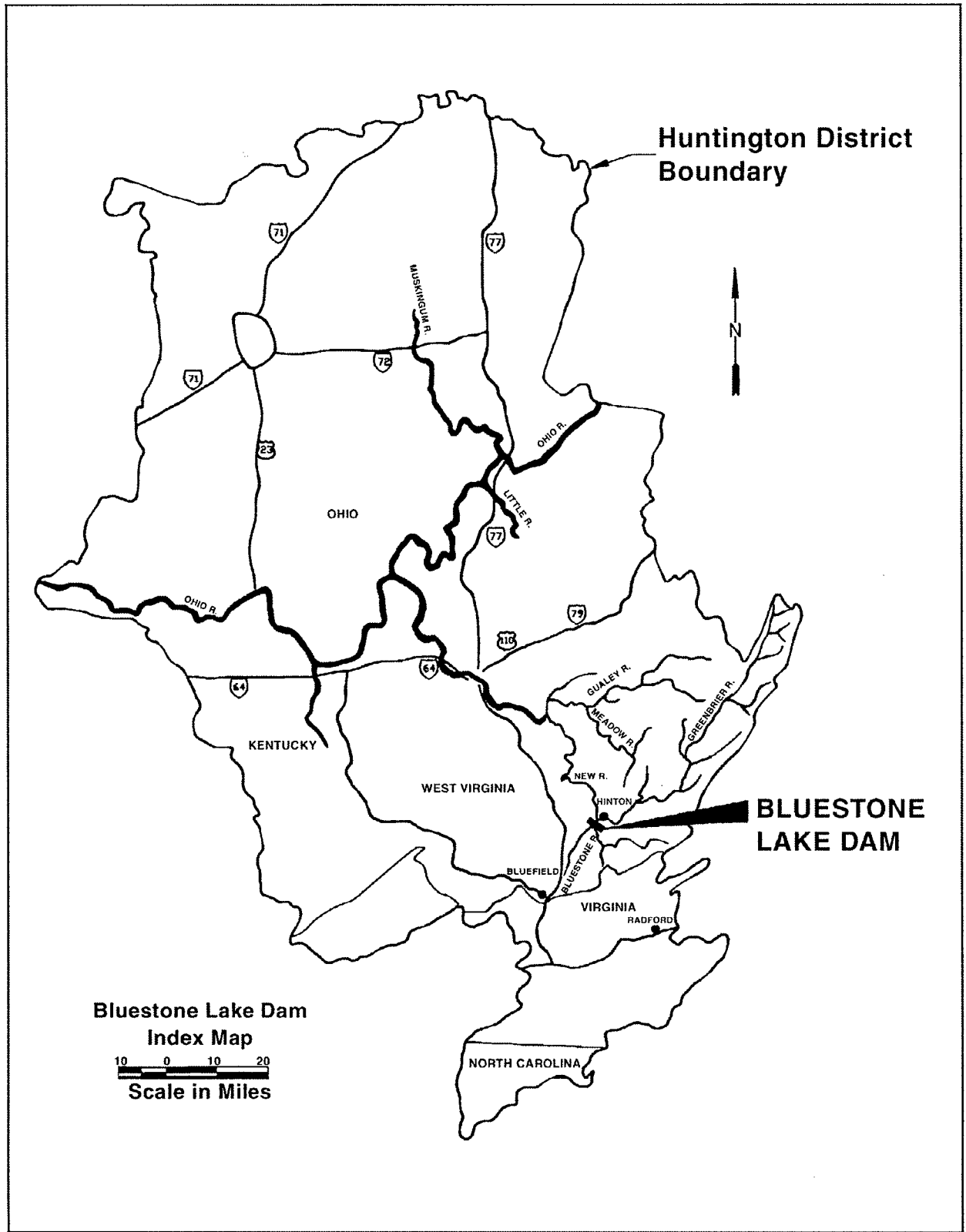

Figure 1. Site location

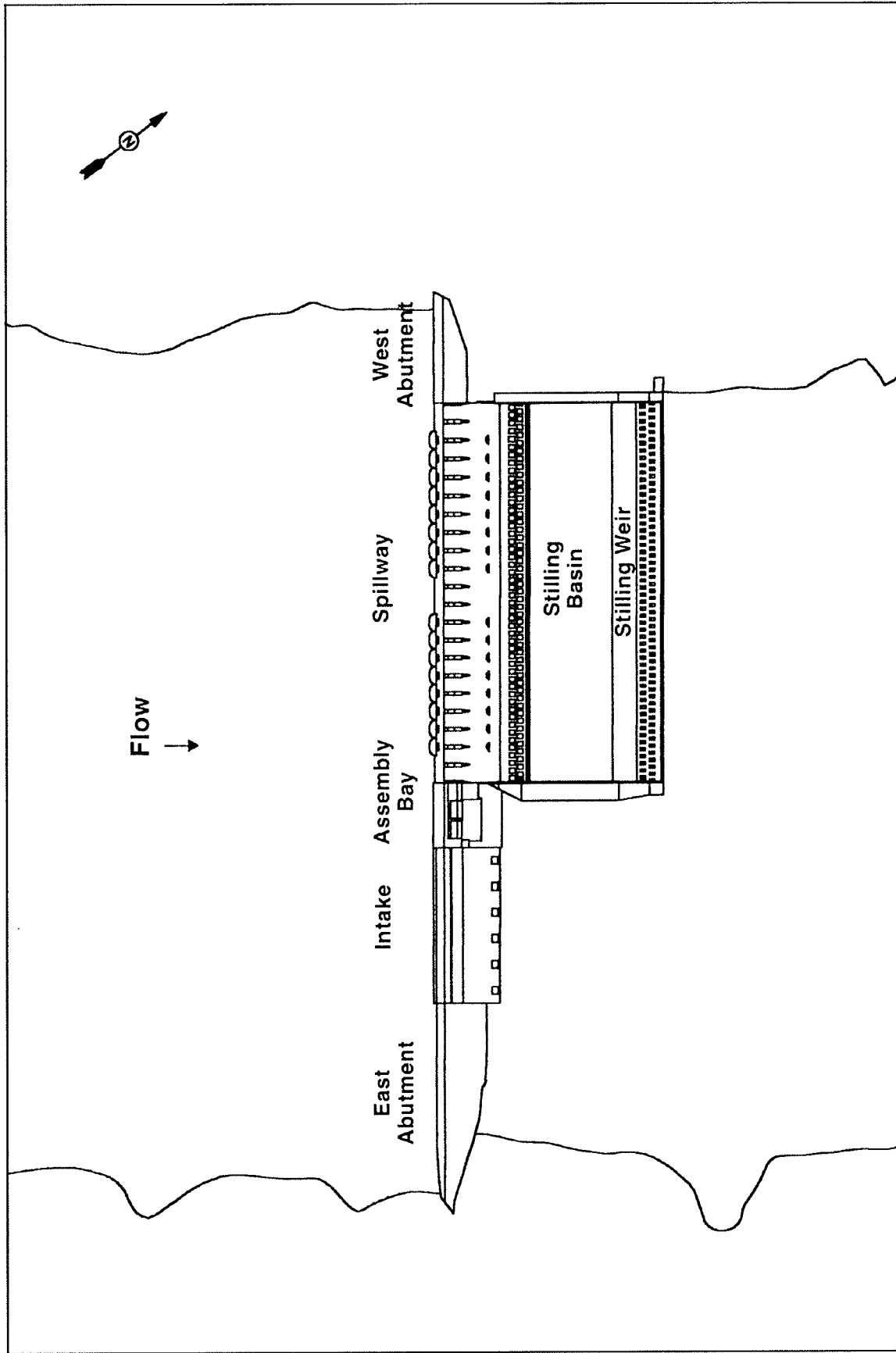

Figure 2. Bluestone Lake Dam layout

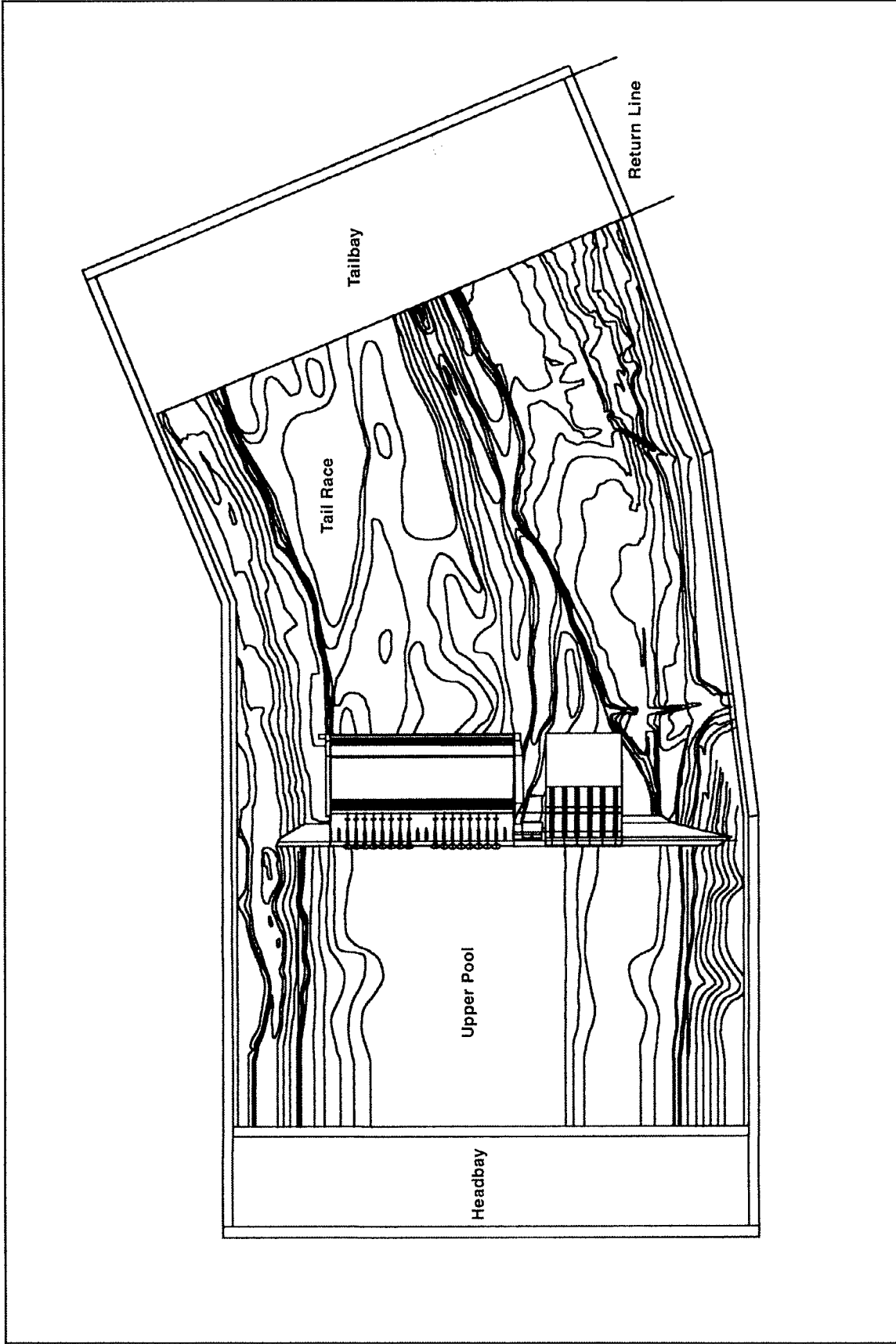

Figure 3. Bluestone 1:65 scale, model layout

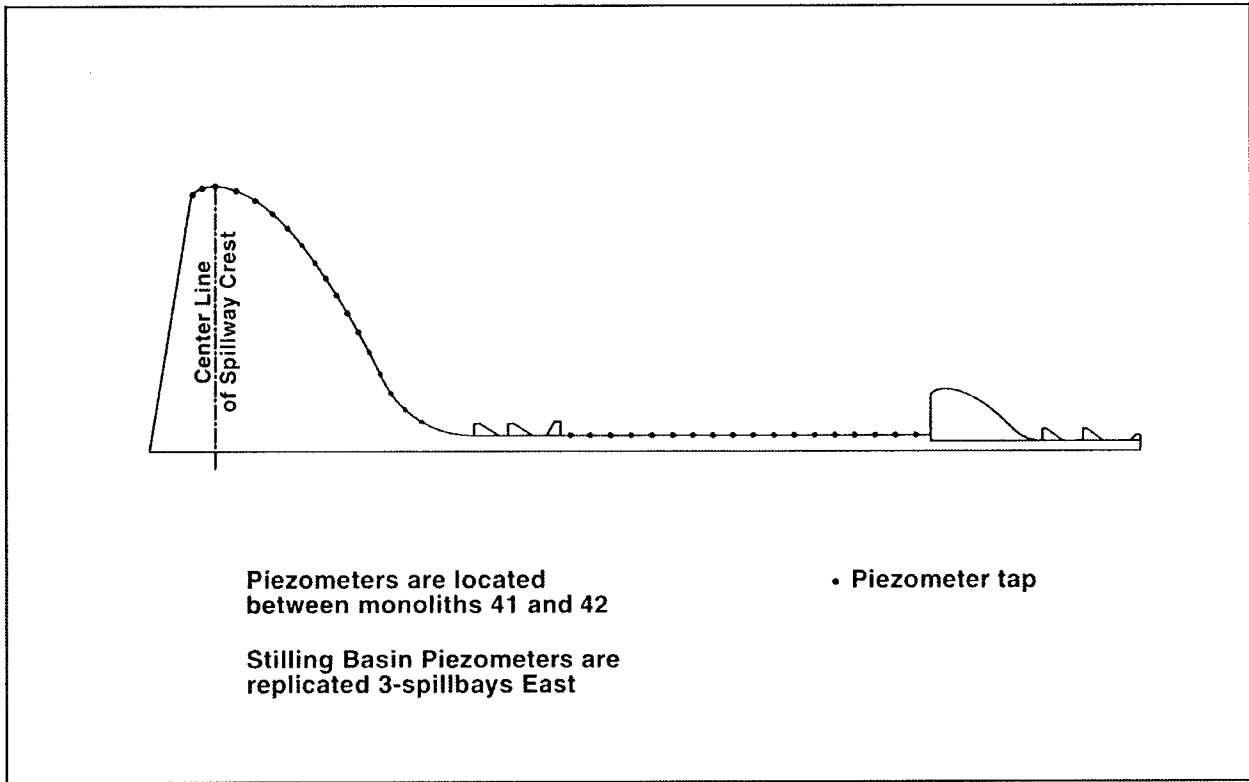

Figure 4. Piezometer tap locations, spillway, and stilling basin

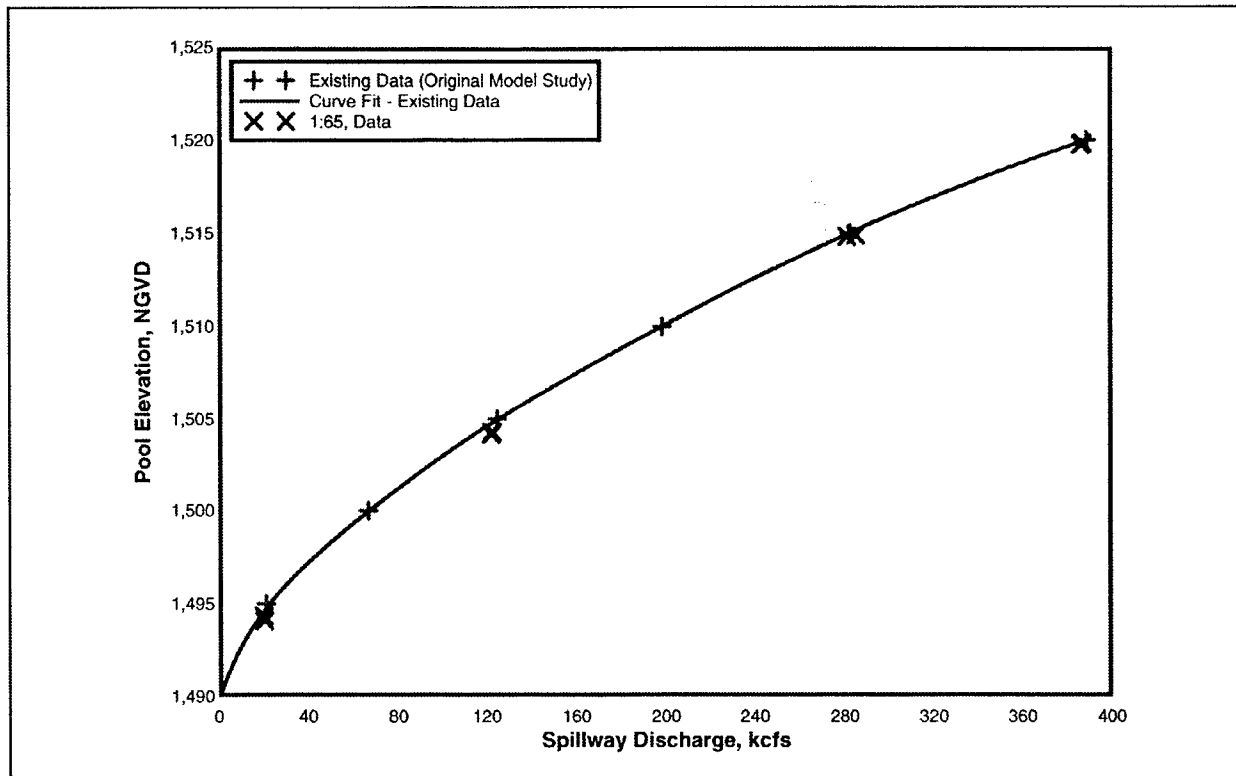

Figure 5. Spillway rating verification curve

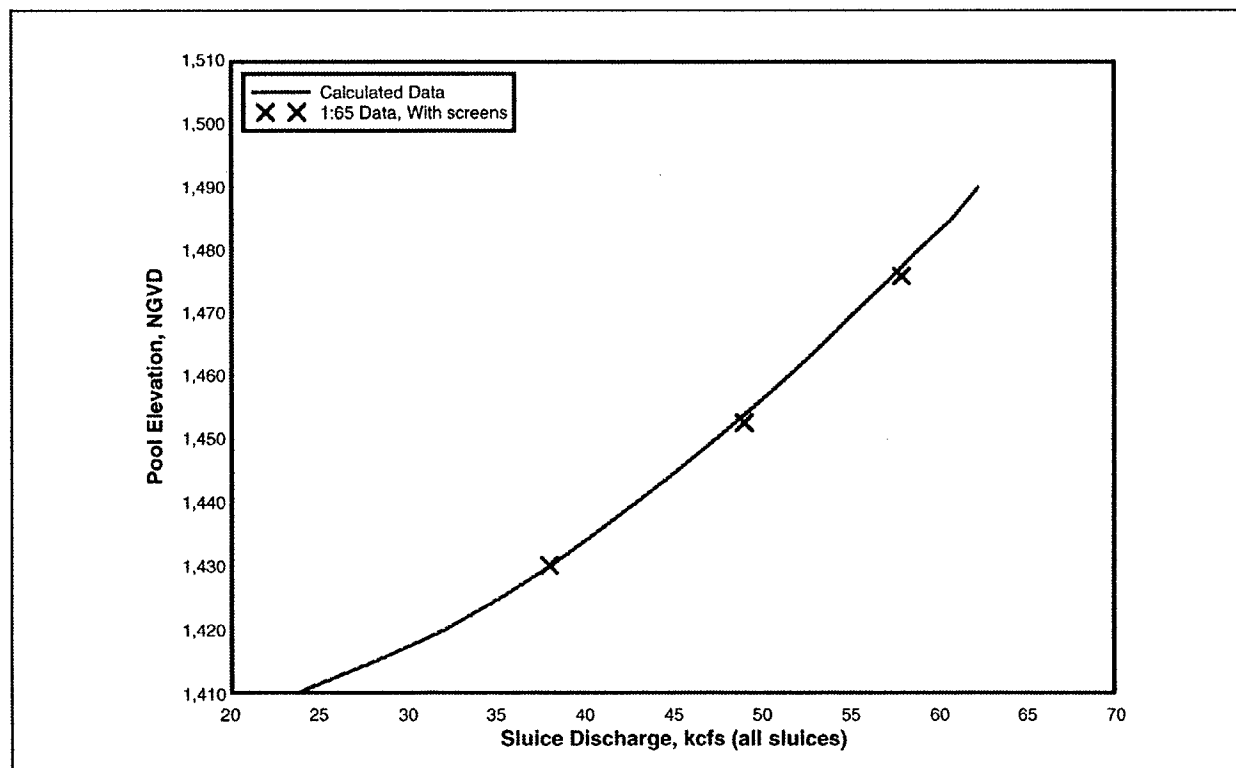

Figure 6. Sluice rating verification curve

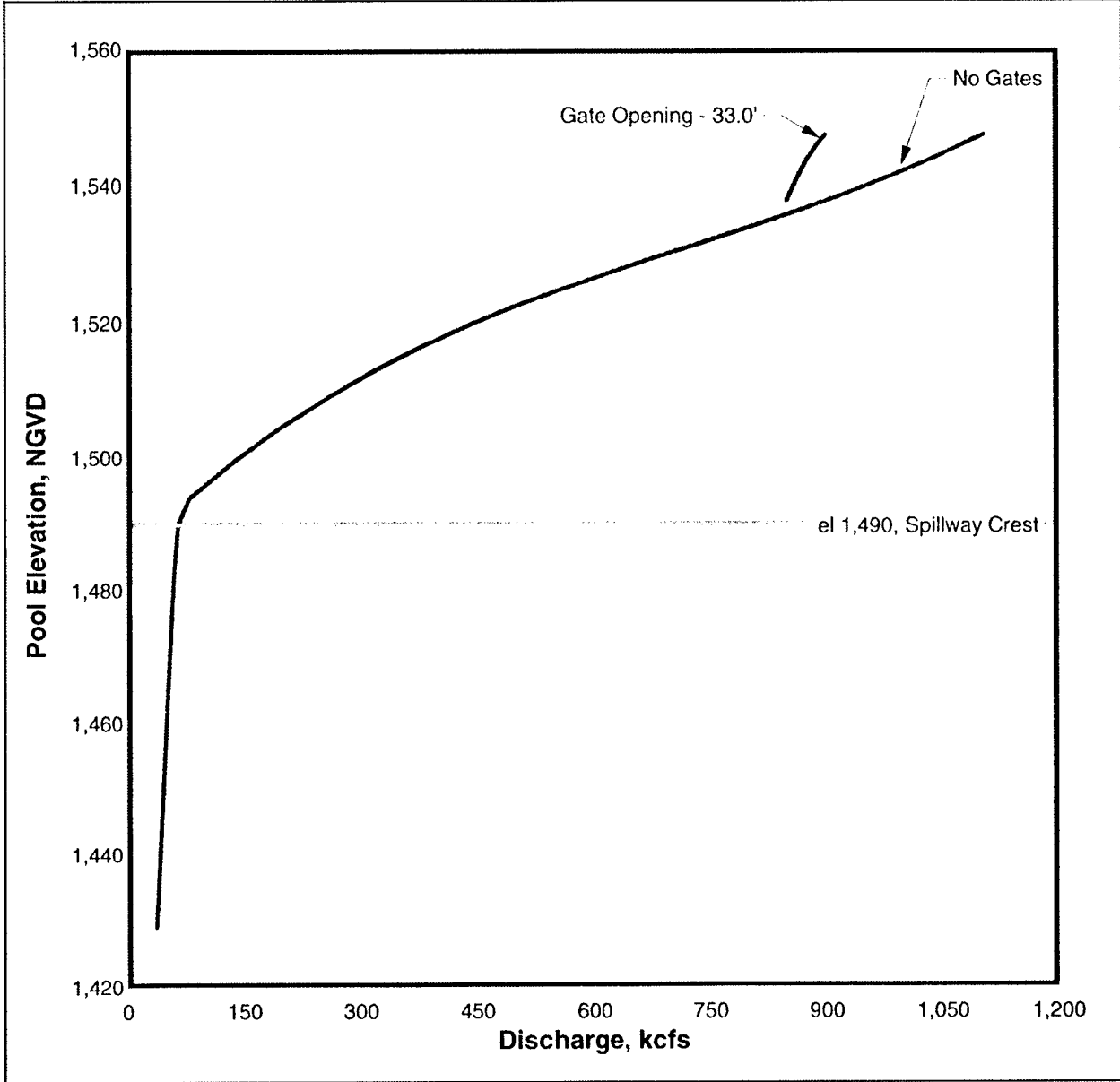

Figure 7. Extended rating curve, spillway, and sluice discharge only

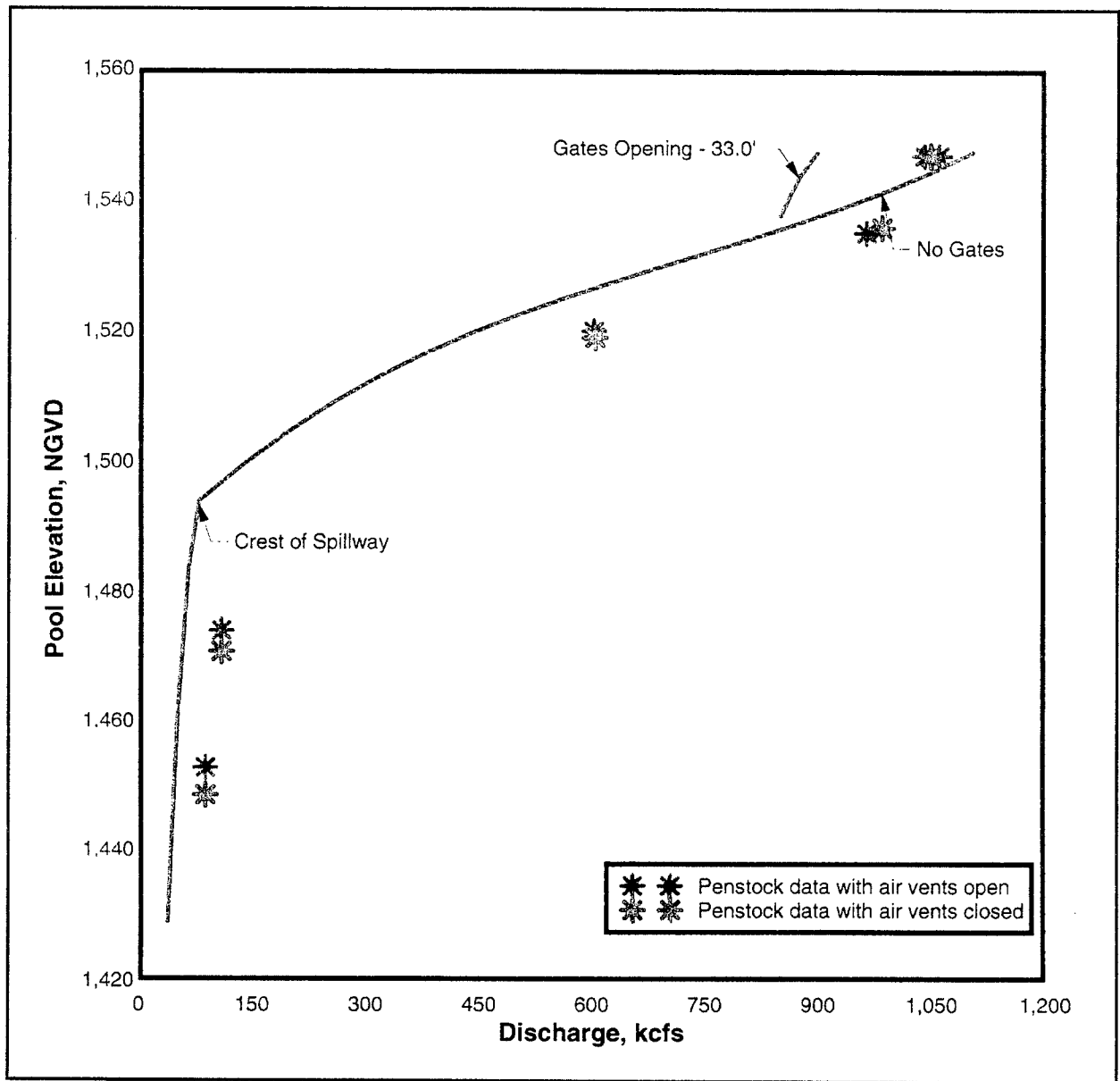

Figure 8. Extended rating curve, spillway, sluice, and penstock discharge

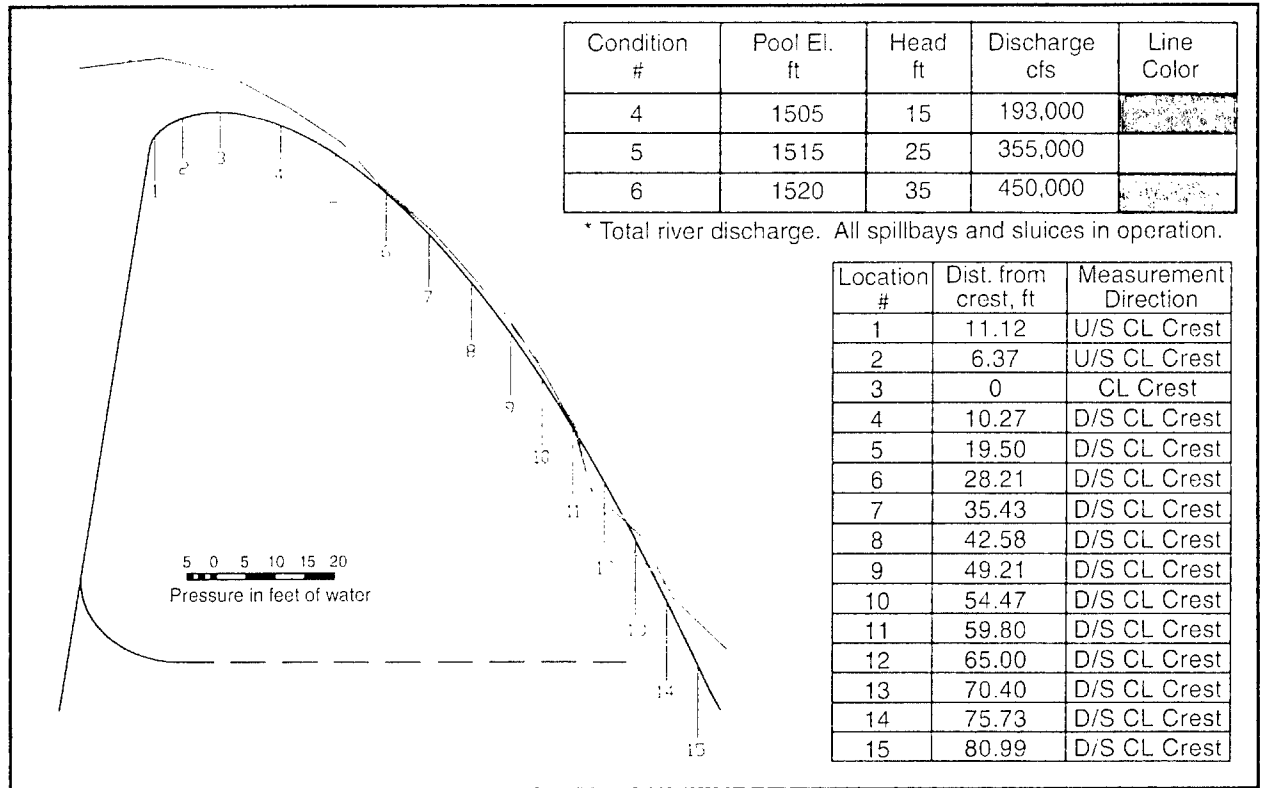

Figure 9. Spillway pressure for conditions 4 through 6

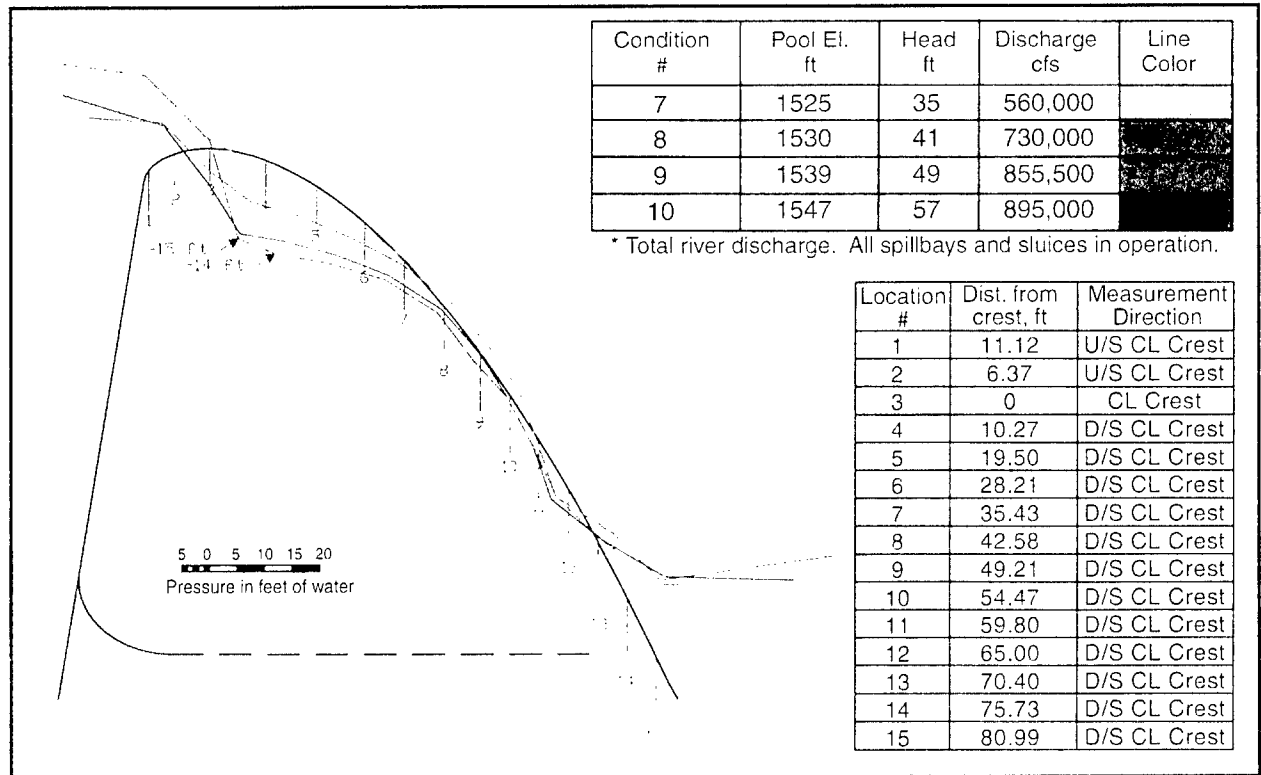

Figure 10. Spillway pressures for conditions 7 through 10

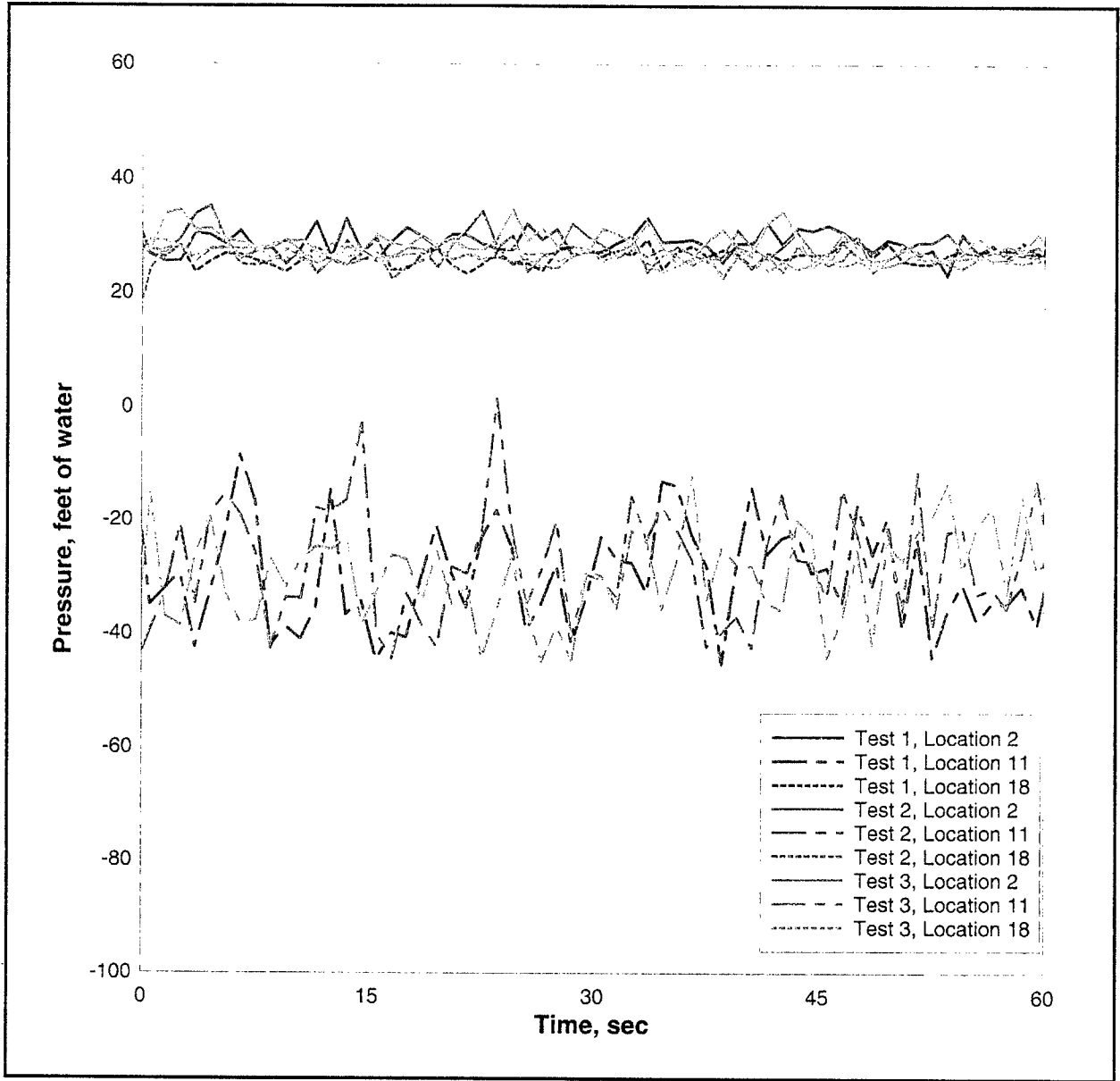

Figure 11. Pressure cell data, stilling basin, condition 4, downstream of spillbay 5

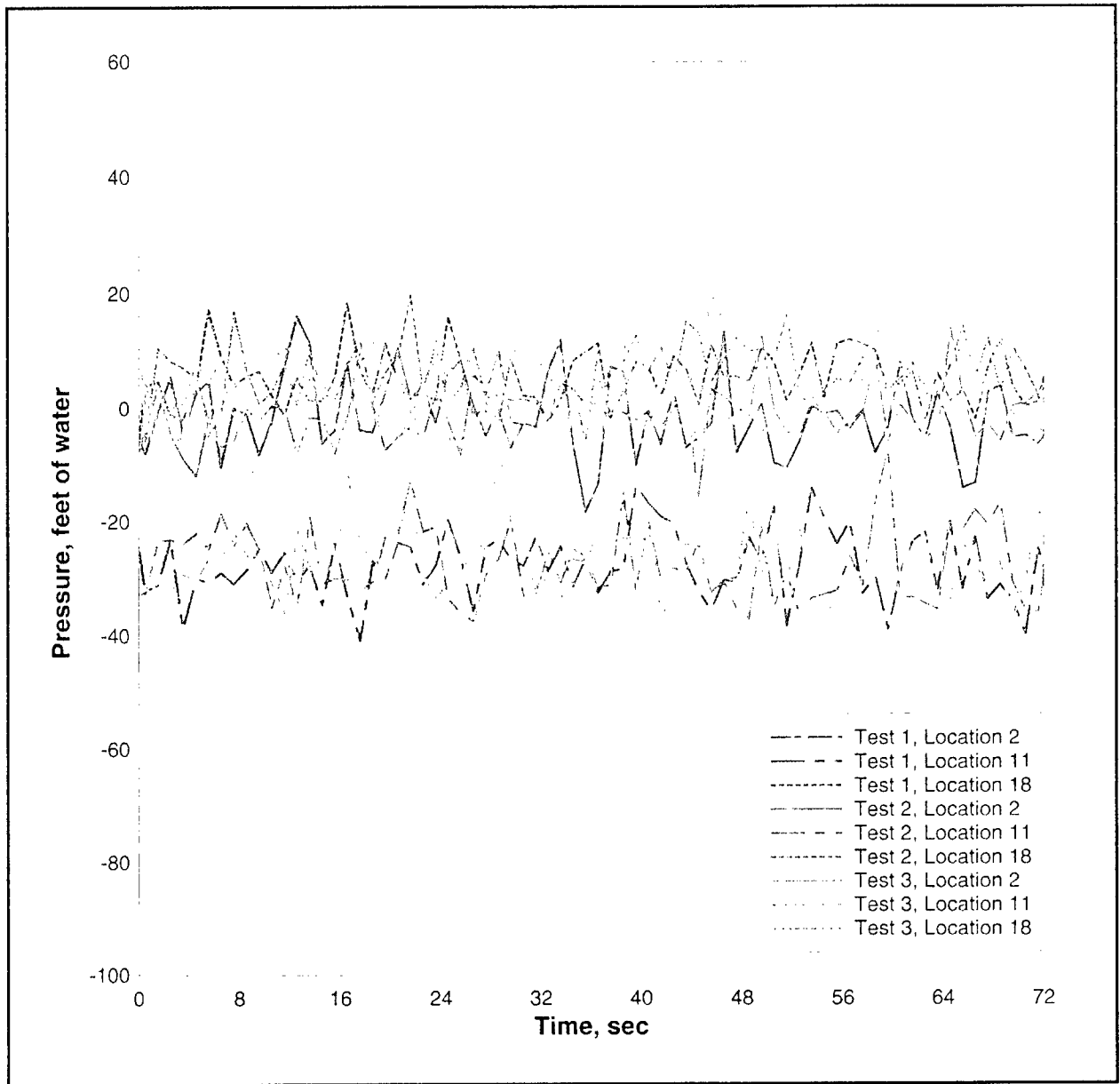

Figure 12. Pressure cell data, stilling basin, condition 4, downstream of spillbay 8

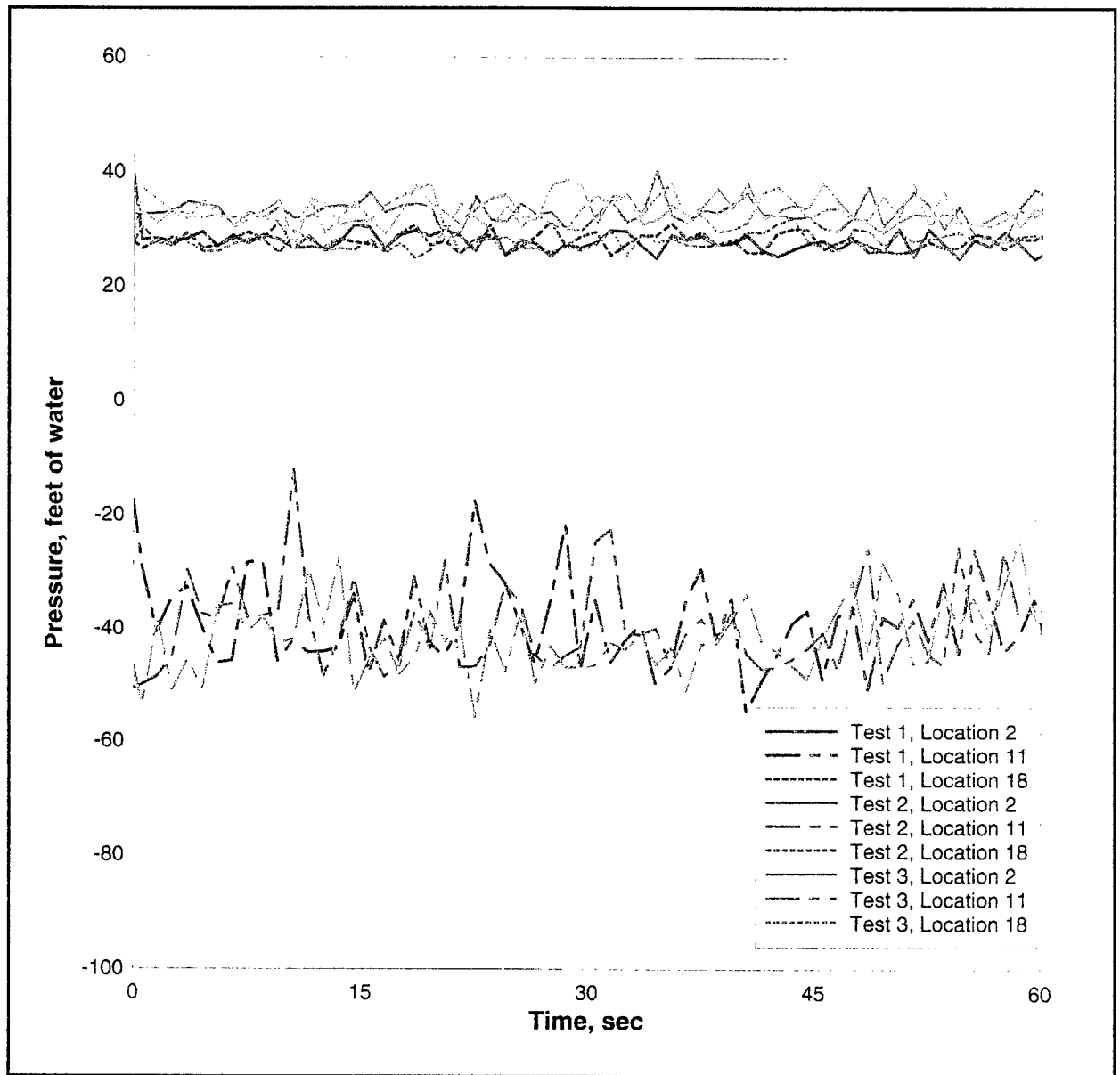

Figure 13. Pressure cell data, stilling basin, condition 5, downstream of spillbay 5

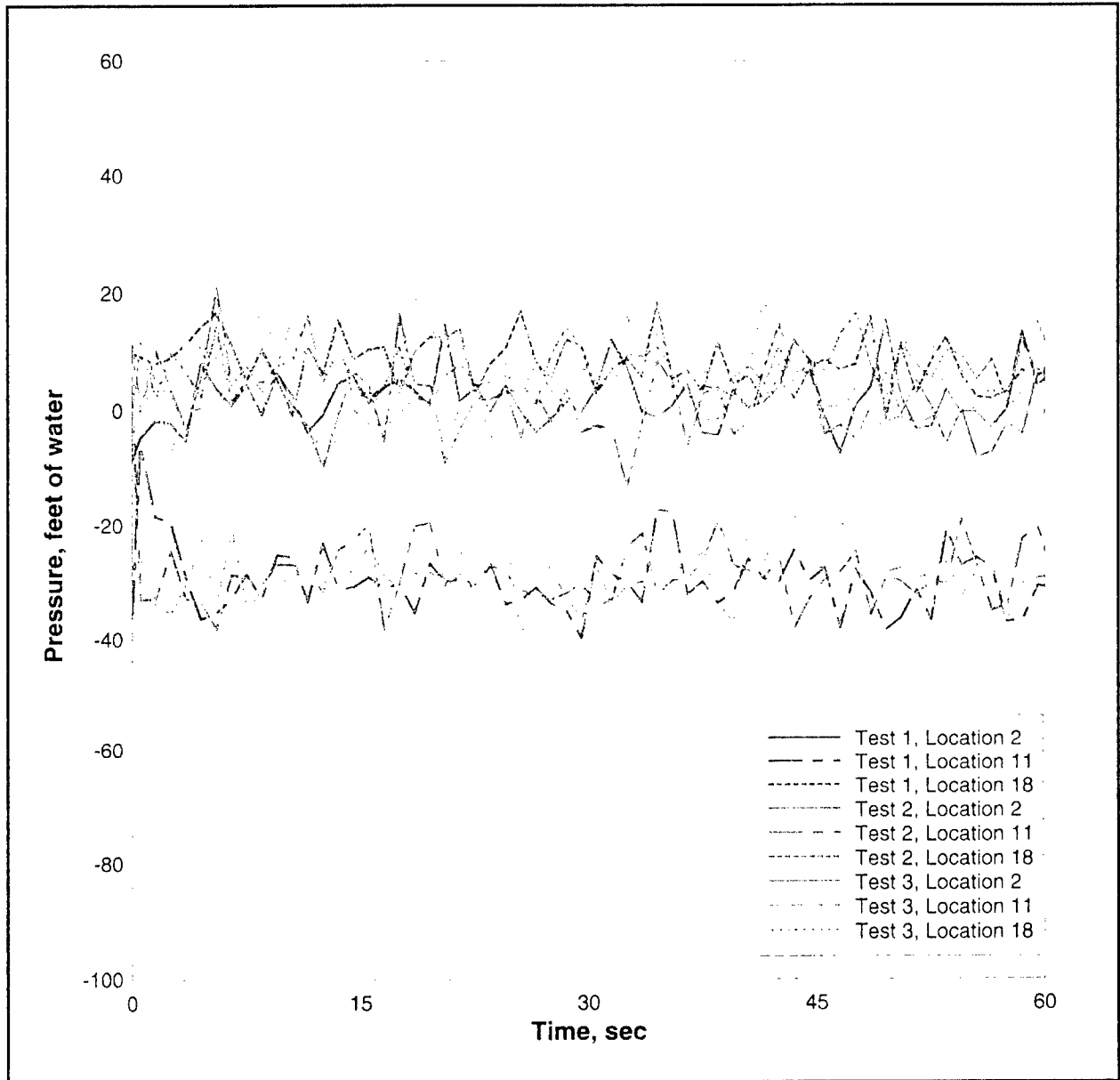

Figure 14. Pressure cell data, stilling basin, condition 5, downstream of spillbay 8

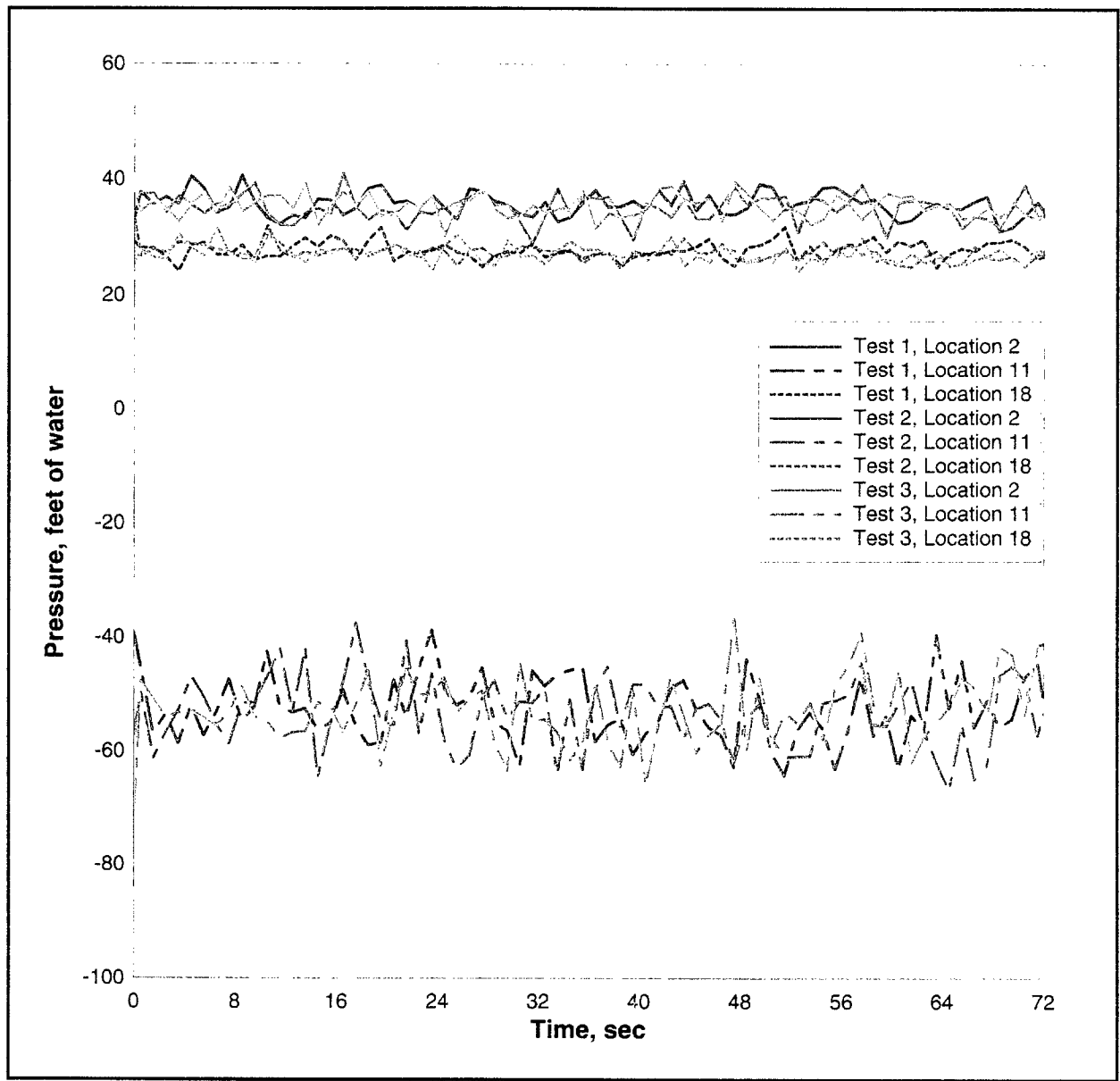

Figure 15. Pressure cell data, stilling basin, condition 6, downstream of spillbay 5

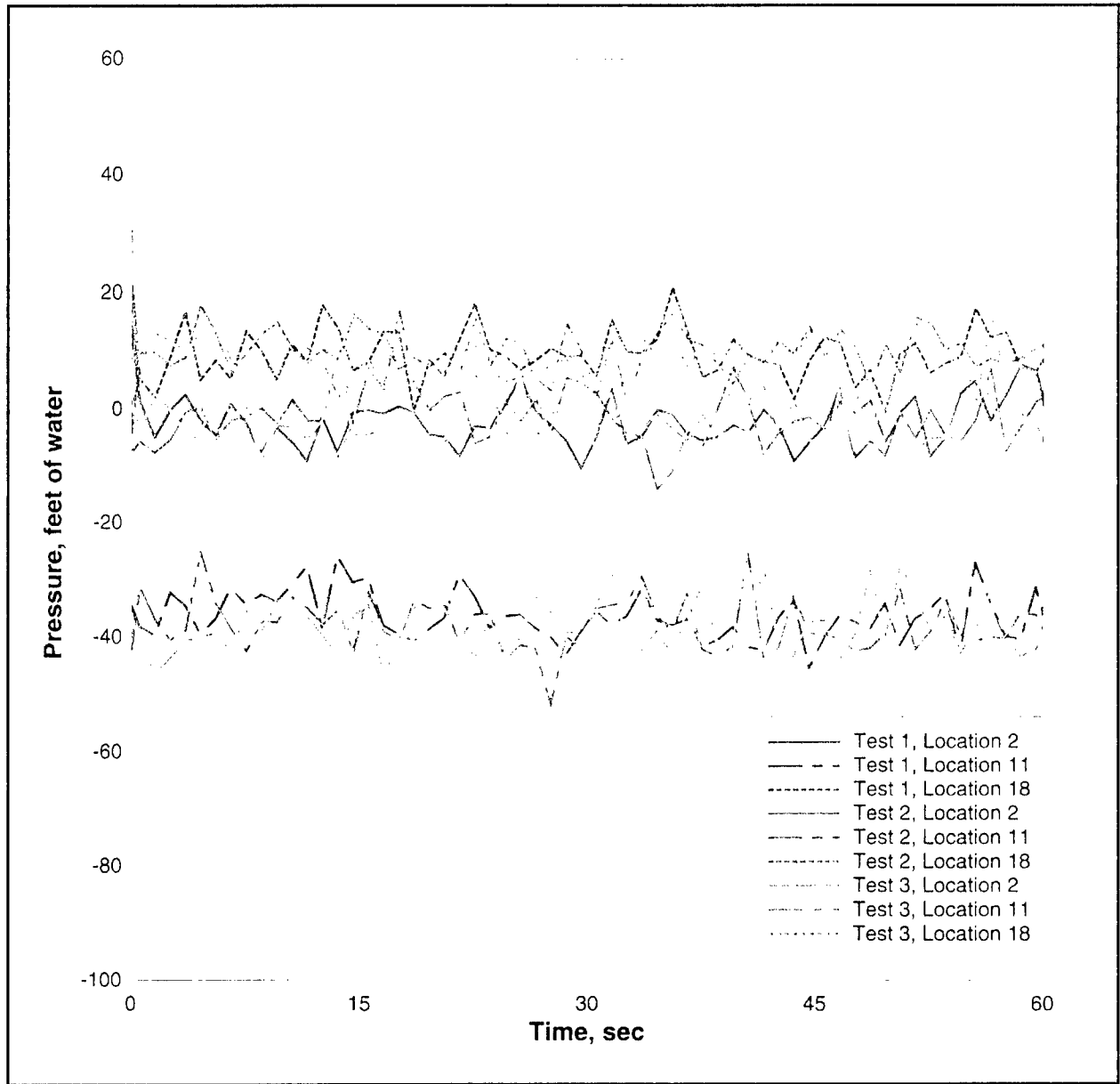

Figure 16. Pressure cell data, stilling basin, condition 6, downstream of spillbay 8

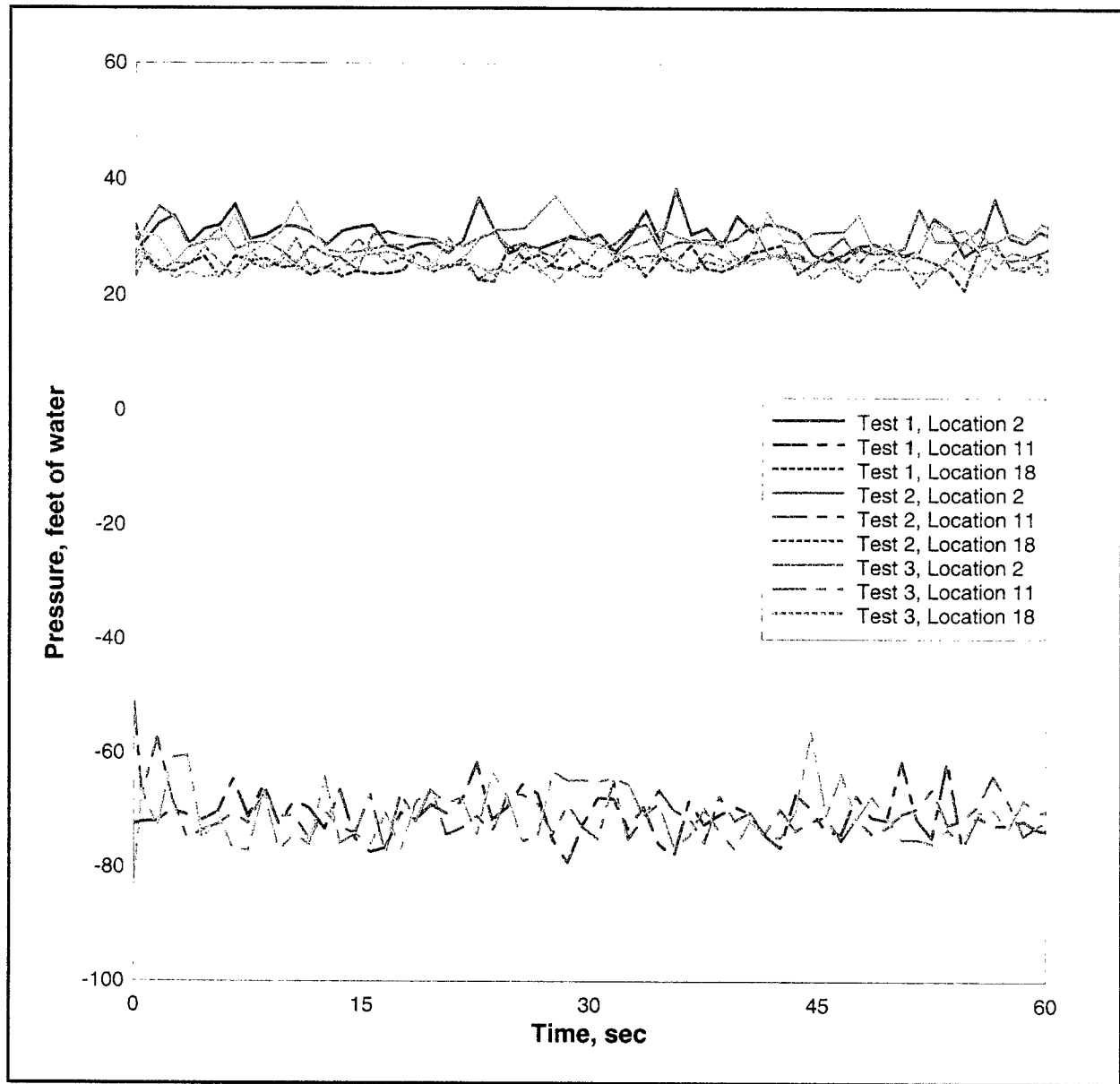

Figure 17. Pressure cell data, stilling basin, condition 7, downstream of spillbay 5

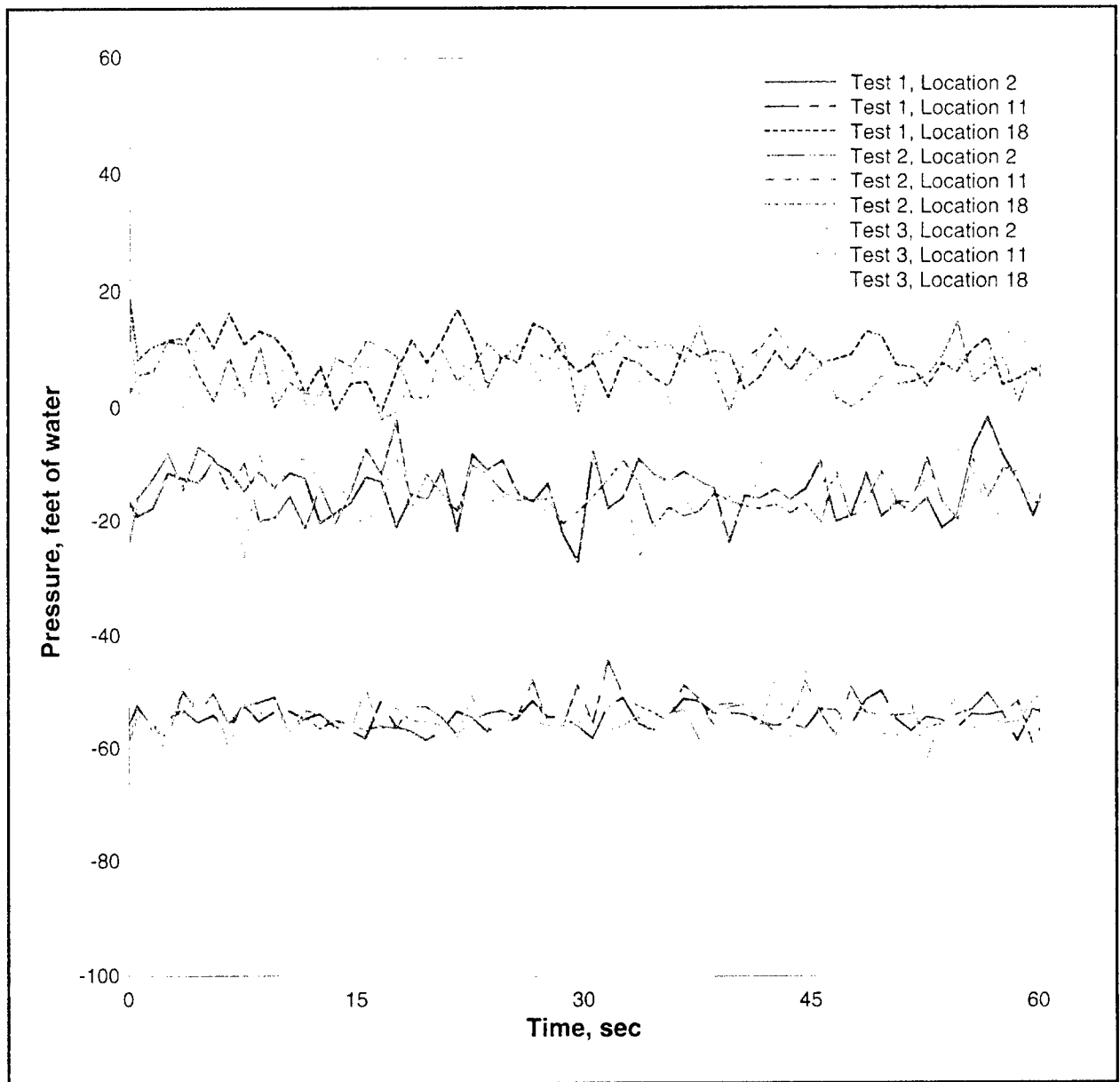

Figure 18. Pressure cell data, stilling basin, condition 7, downstream of spillbay 8

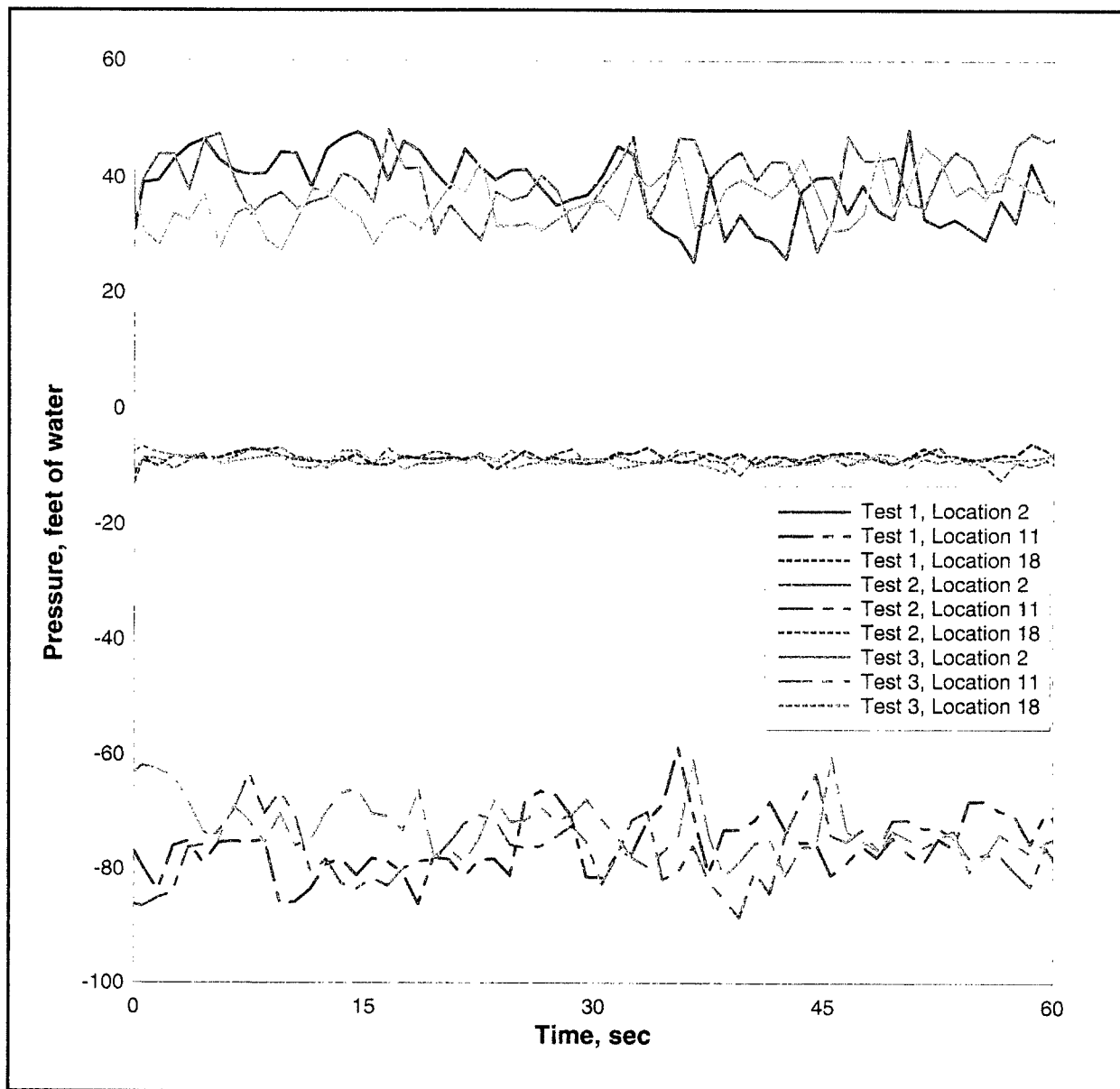

Figure 19. Pressure cell data, stilling basin, condition 8, downstream of spillbay 5

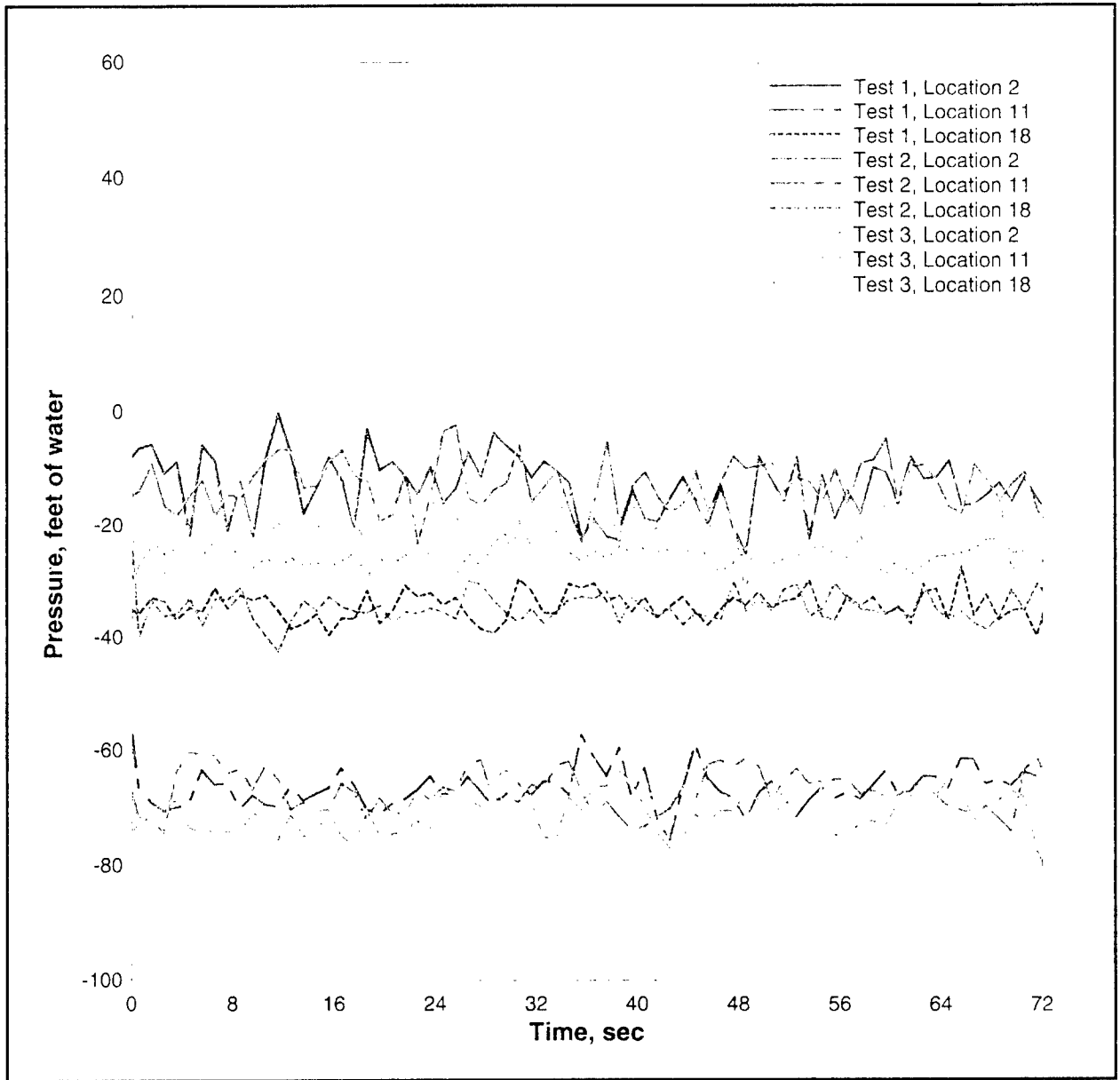

Figure 20. Pressure cell data, stilling basin, condition 8, downstream of spillbay 8

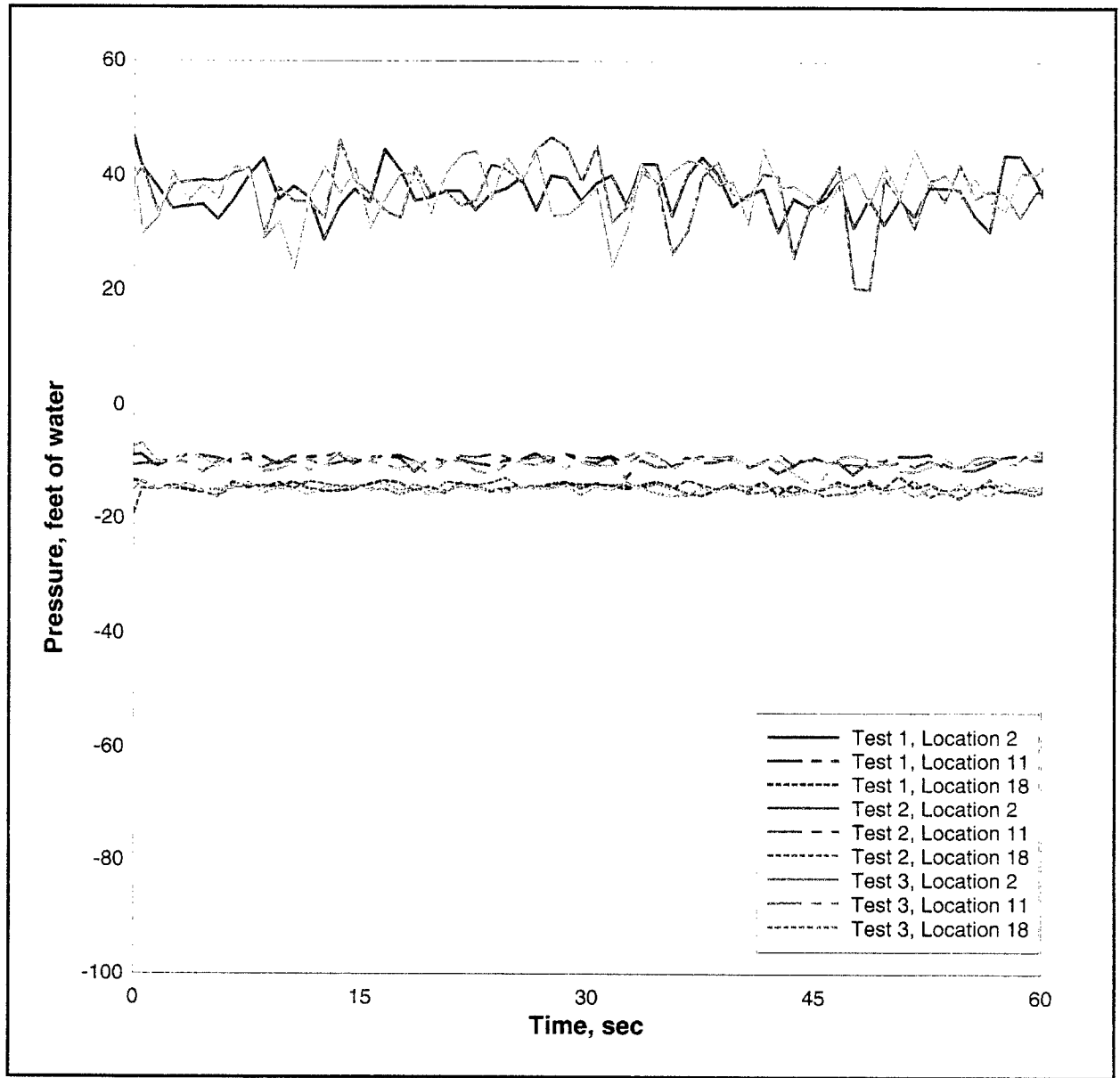

Figure 21. Pressure cell data, stilling basin, condition 9, downstream of spillbay 5

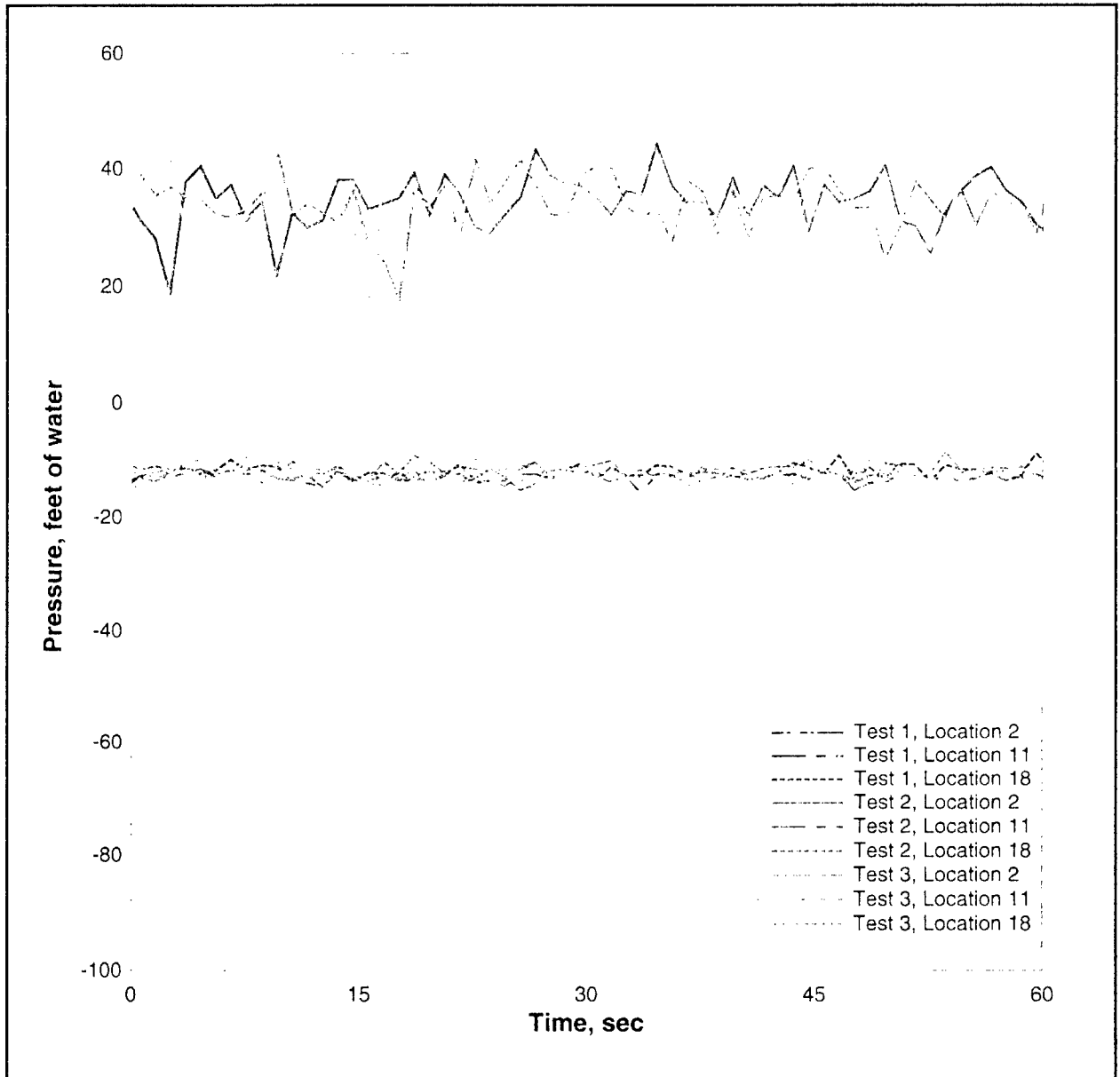

Figure 22. Pressure cell data, stilling basin, condition 9, downstream of spillbay 8

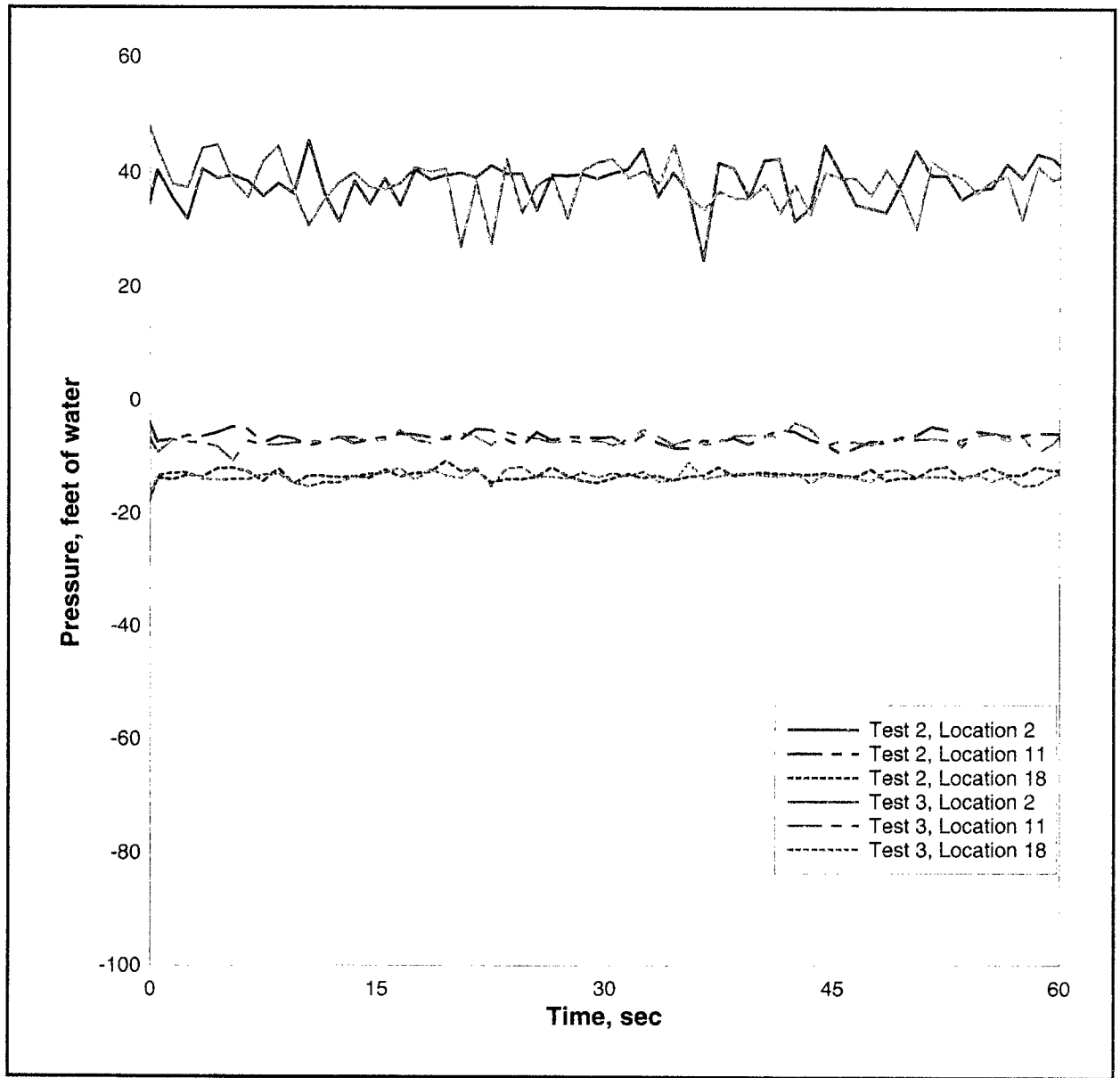

Figure 23. Pressure cell data, stilling basin, condition 10, downstream of spillbay 5

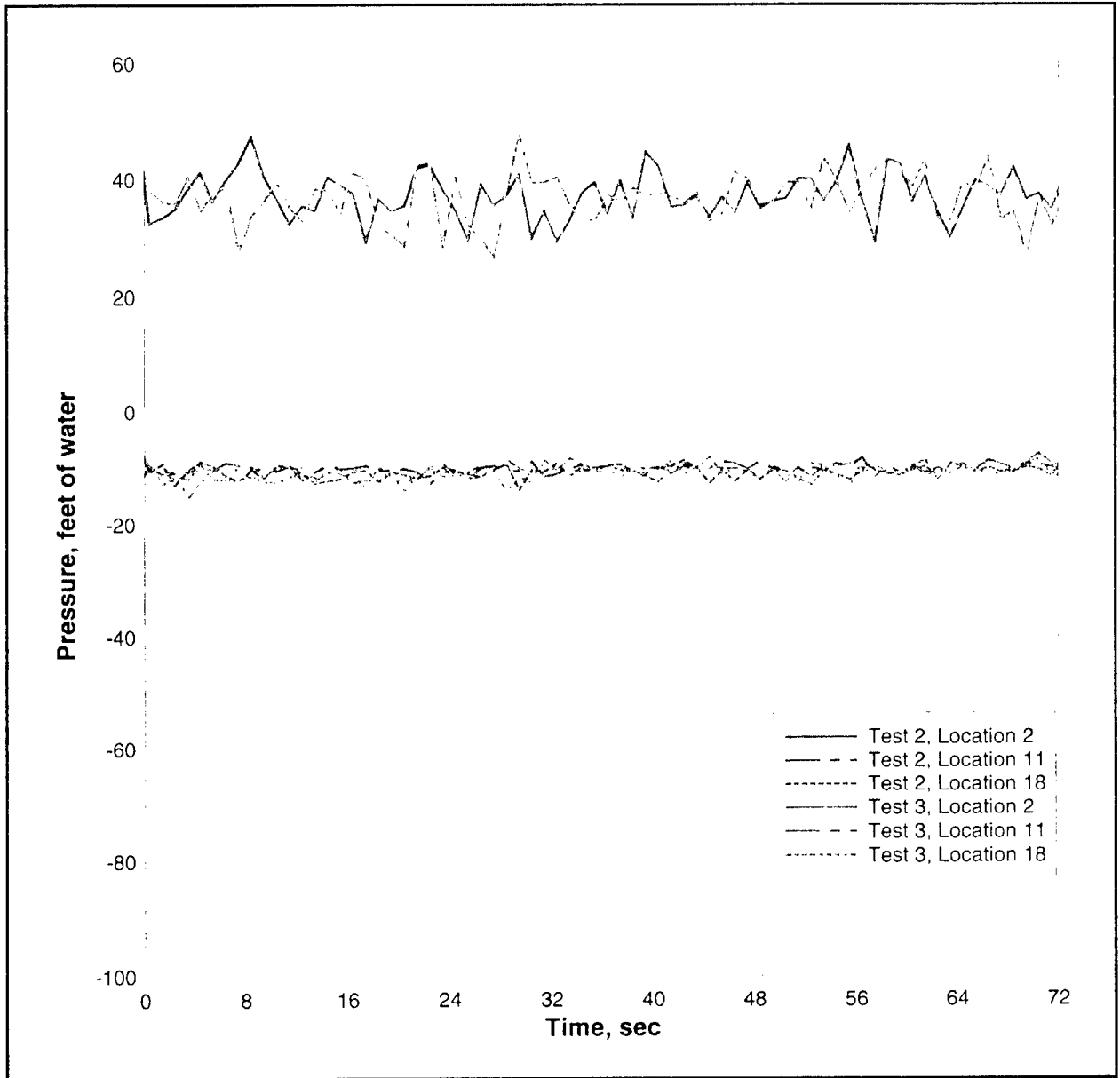

Figure 24. Pressure cell data, stilling basin, condition 10, downstream of spillbay 8

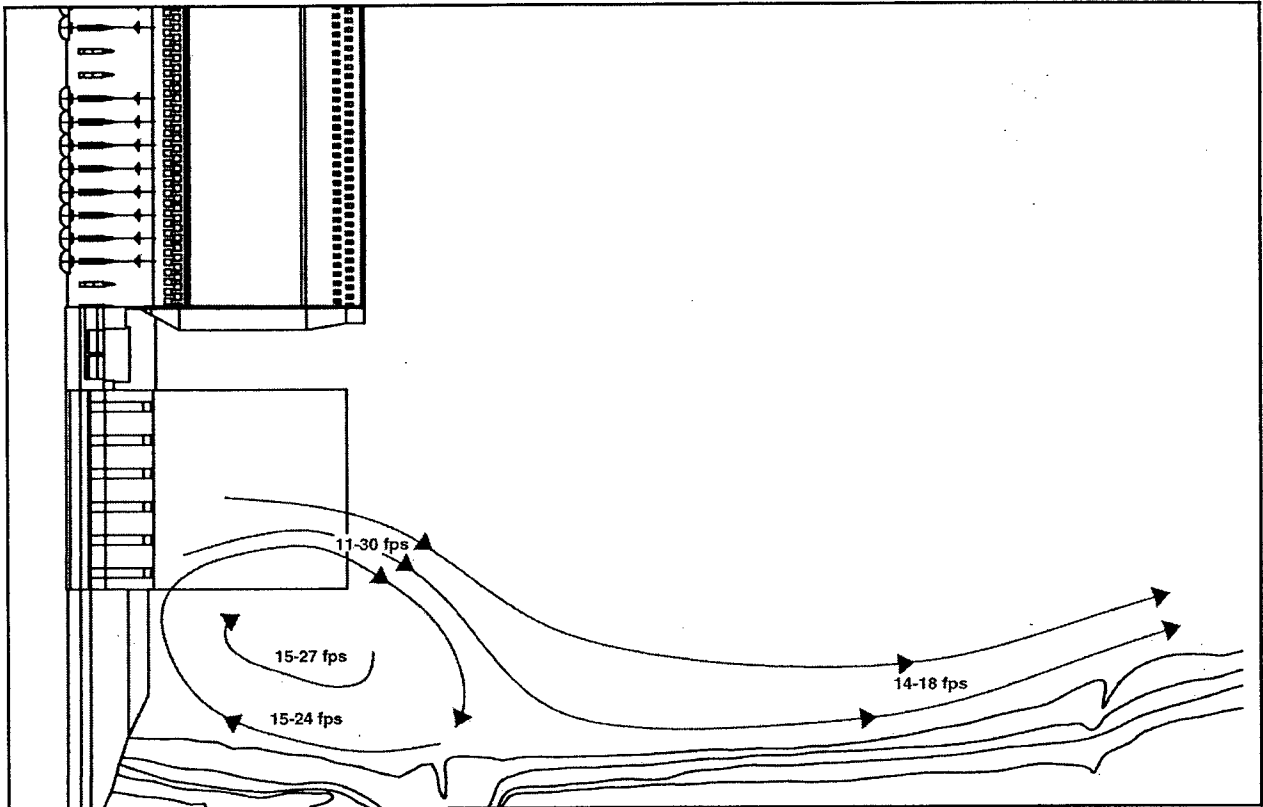

Figure 25. Size and intensity of eddy downstream of penstocks during PMF

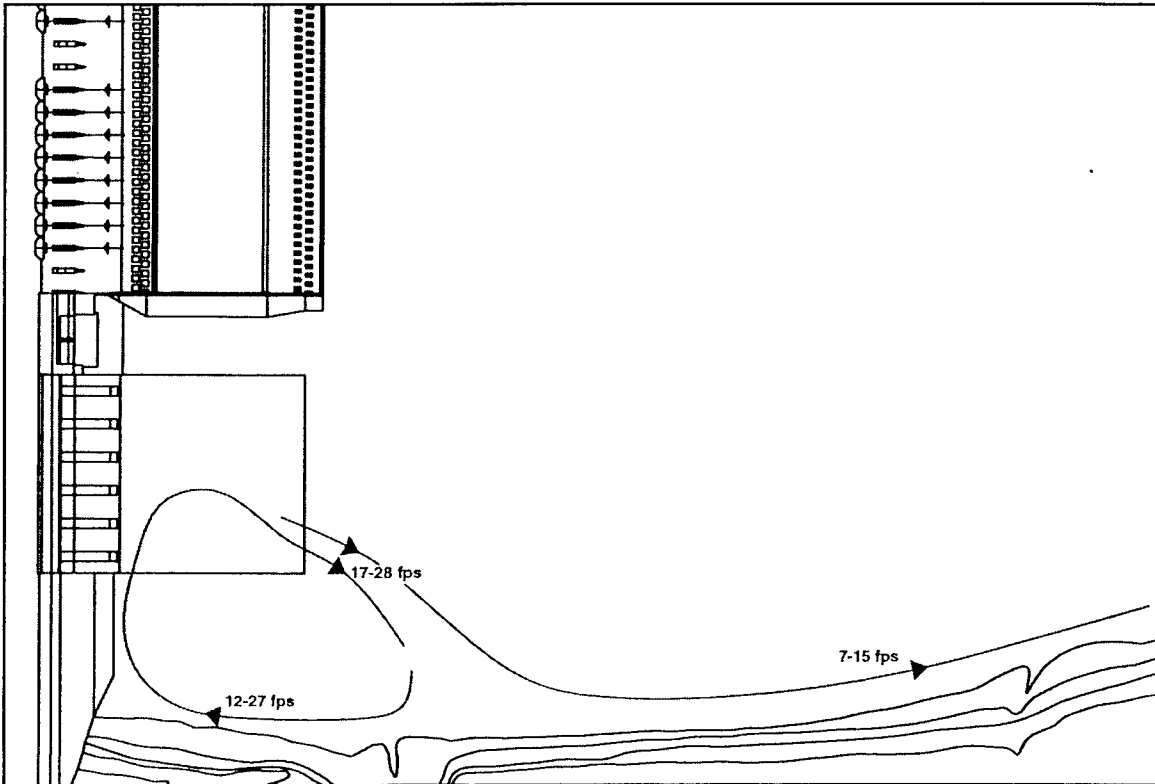

Figure 26. Size and intensity of eddy downstream of penstocks during PMF with 15 deg of deflection toward right bank

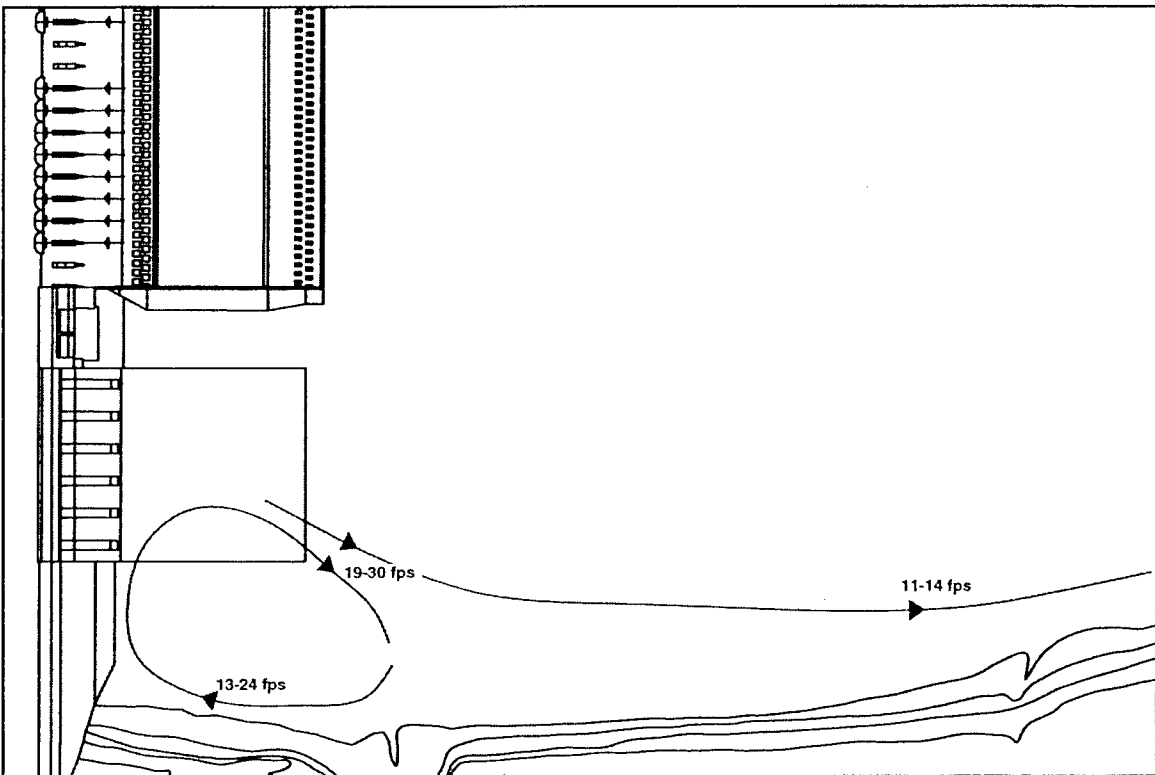

Figure 27. Size and intensity of eddy downstream of penstocks during PMF with 30 deg of deflection toward right bank

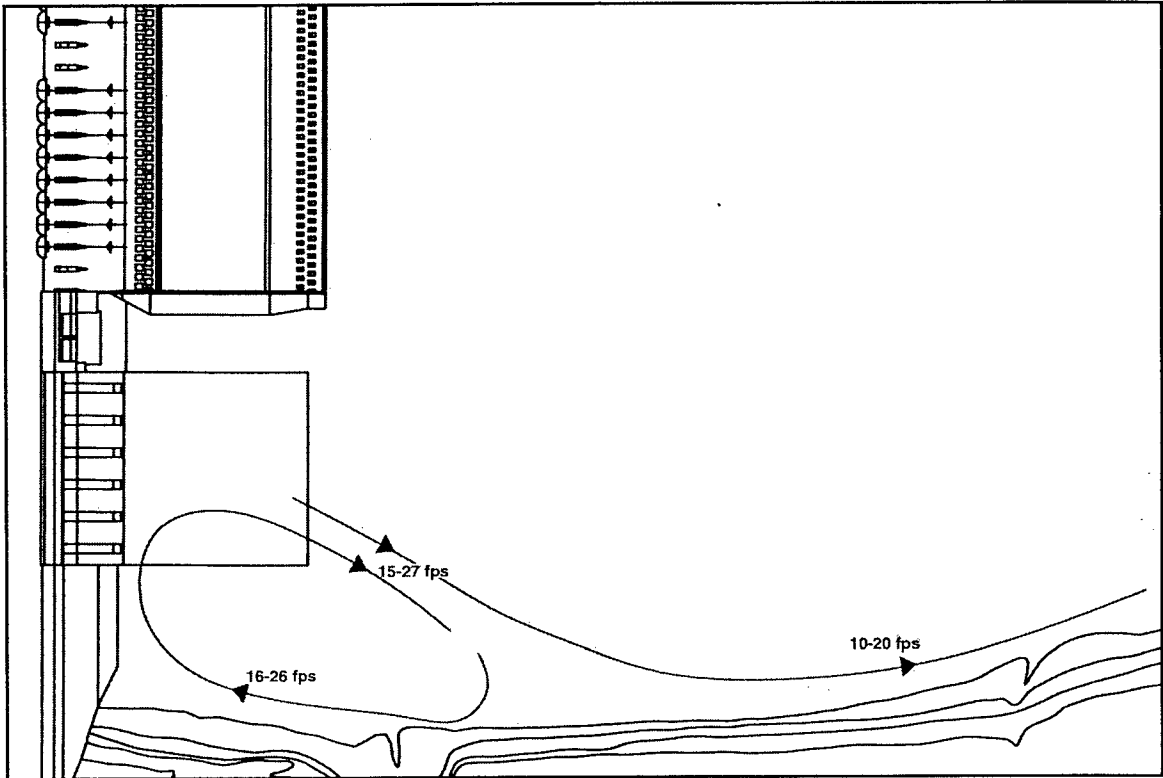

Figure 28. Size and intensity of eddy downstream of penstocks during PMF with 15 deg of deflection toward channel

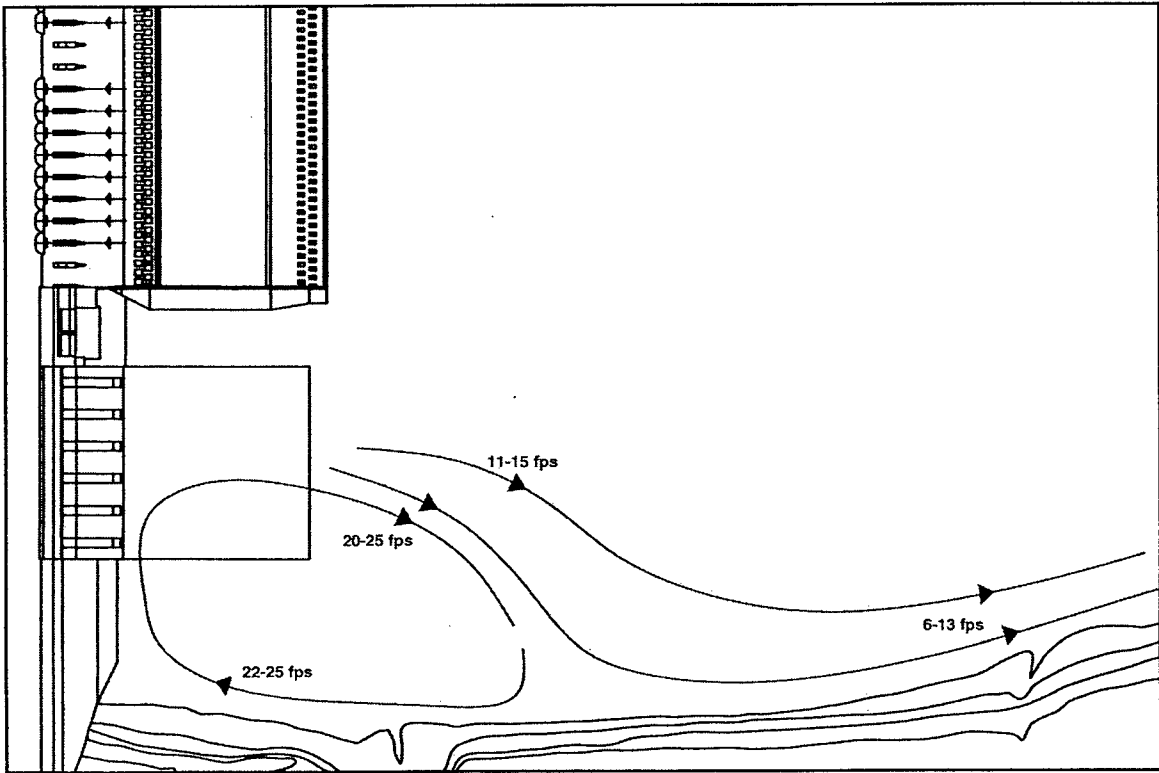

Figure 29. Size and intensity of eddy downstream of penstocks during PMF with 30 deg of deflection toward channel

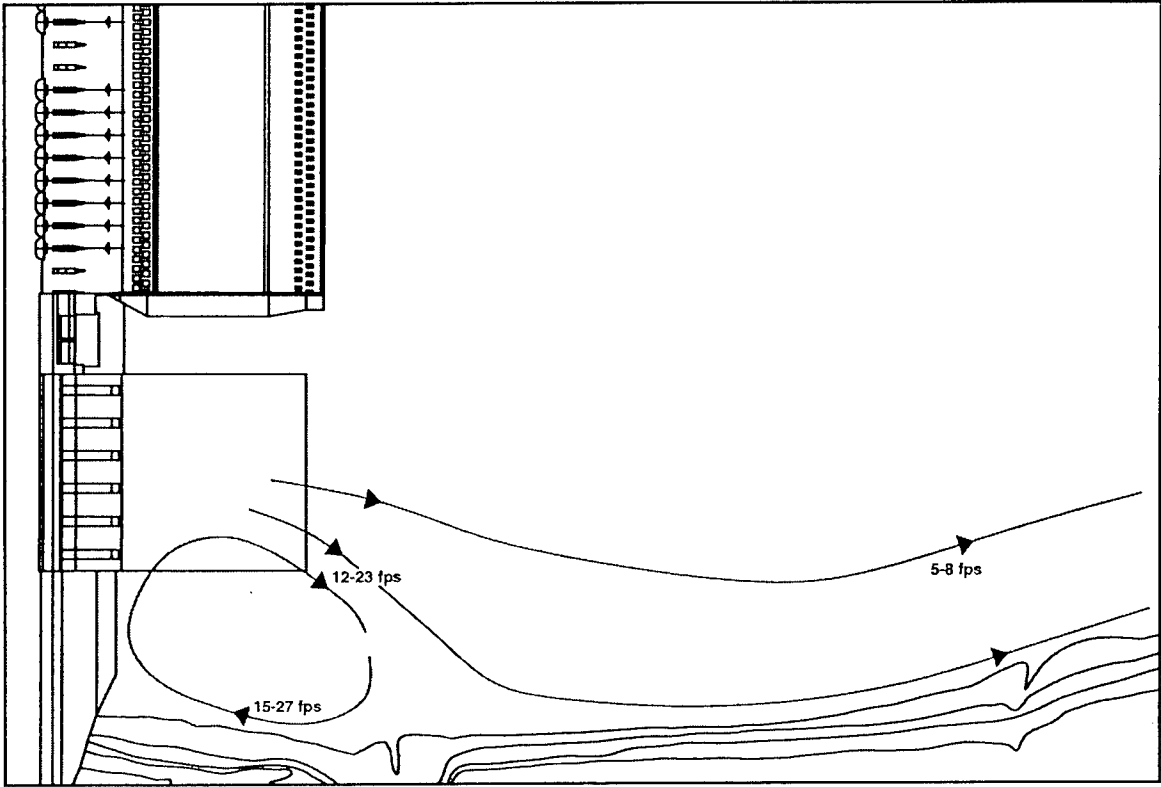

Figure 30. Size and intensity of eddy downstream of penstocks during PMF with 15 deg of upward deflection

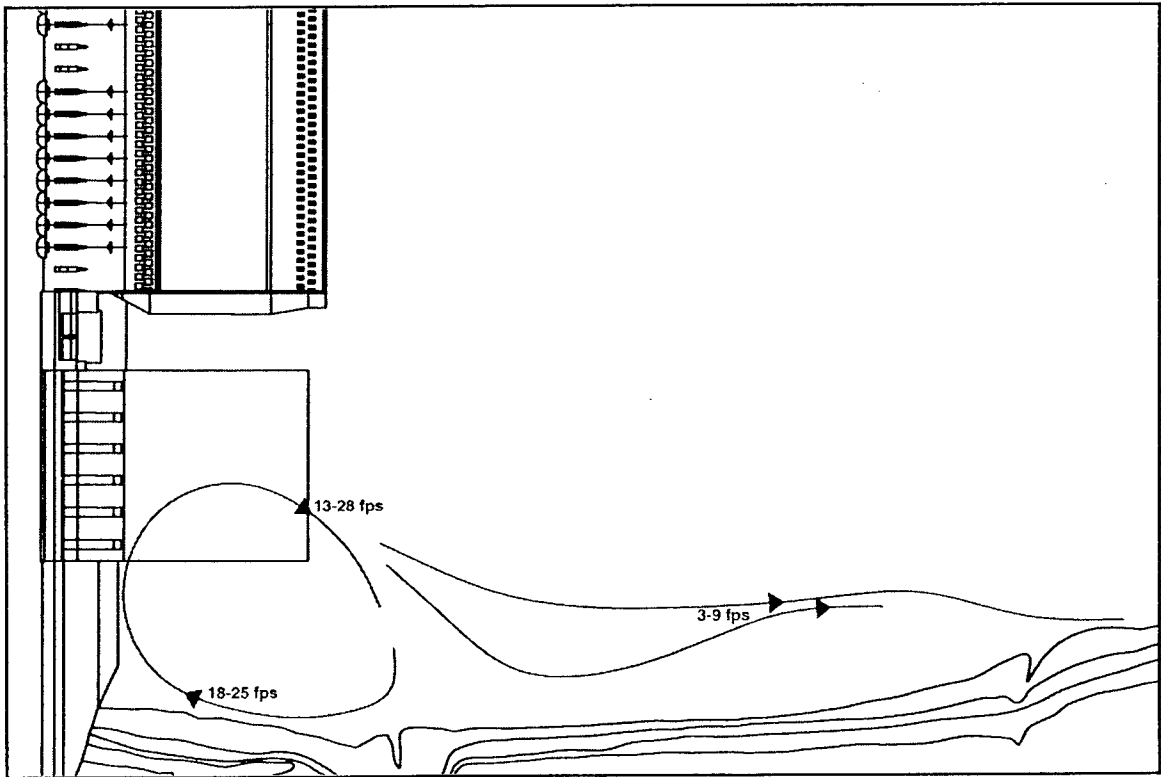

Figure 31. Size and intensity of eddy downstream of penstocks during PMF with 30 deg of upward deflection

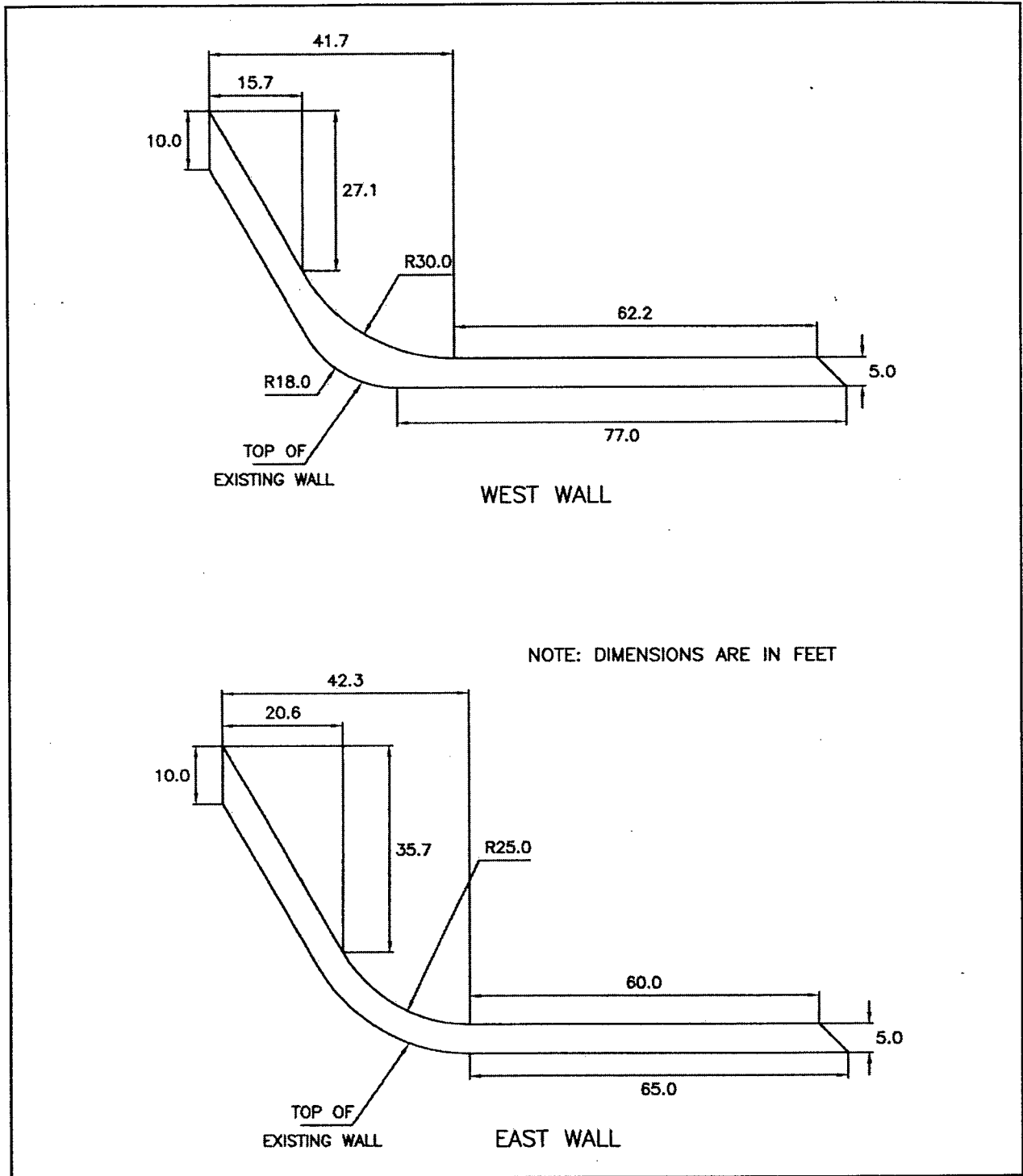

Figure 32. Final training wall designs

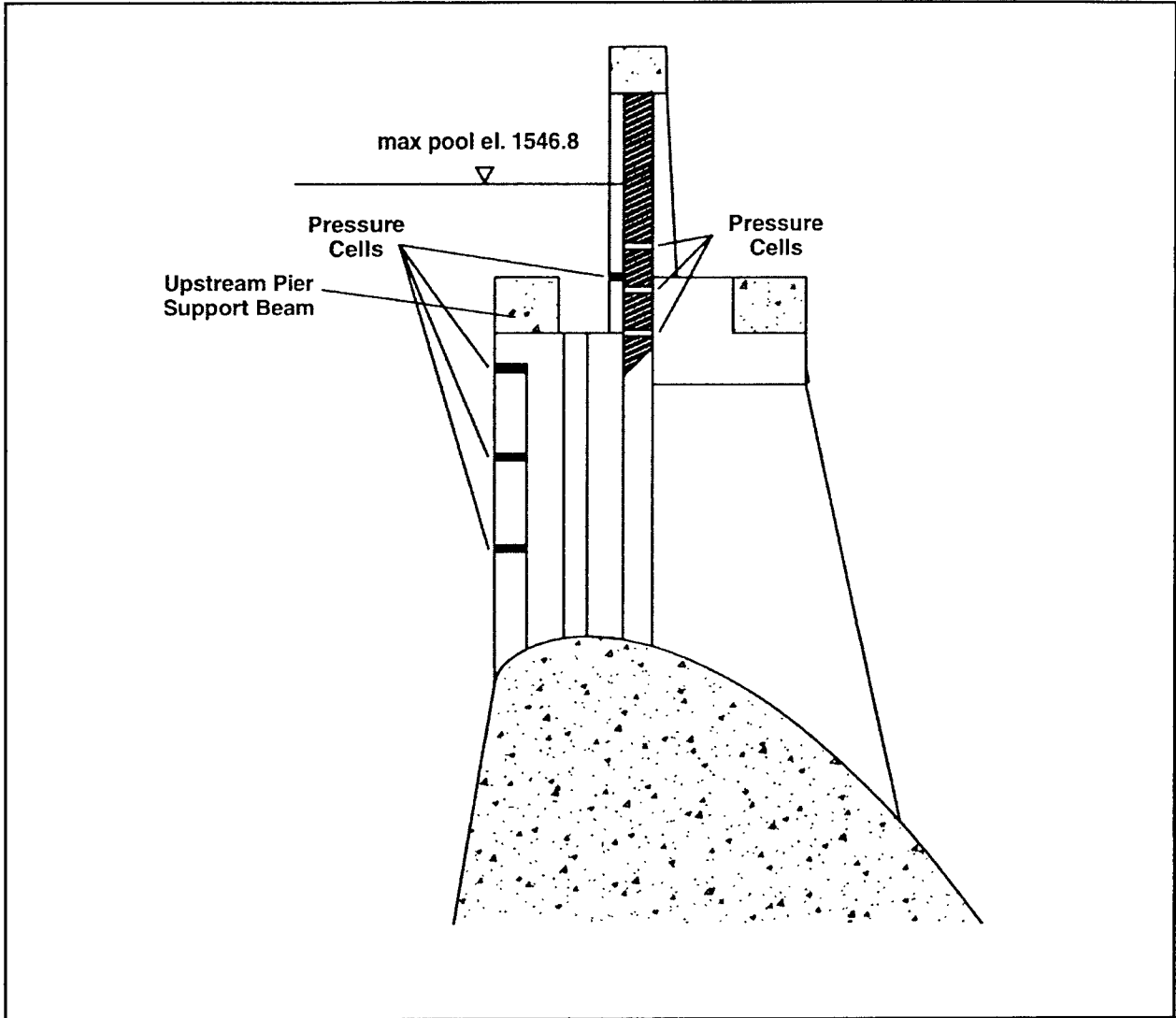

Figure 33. Cross section of spillway showing spill gate, pressure cell locations, and support beam

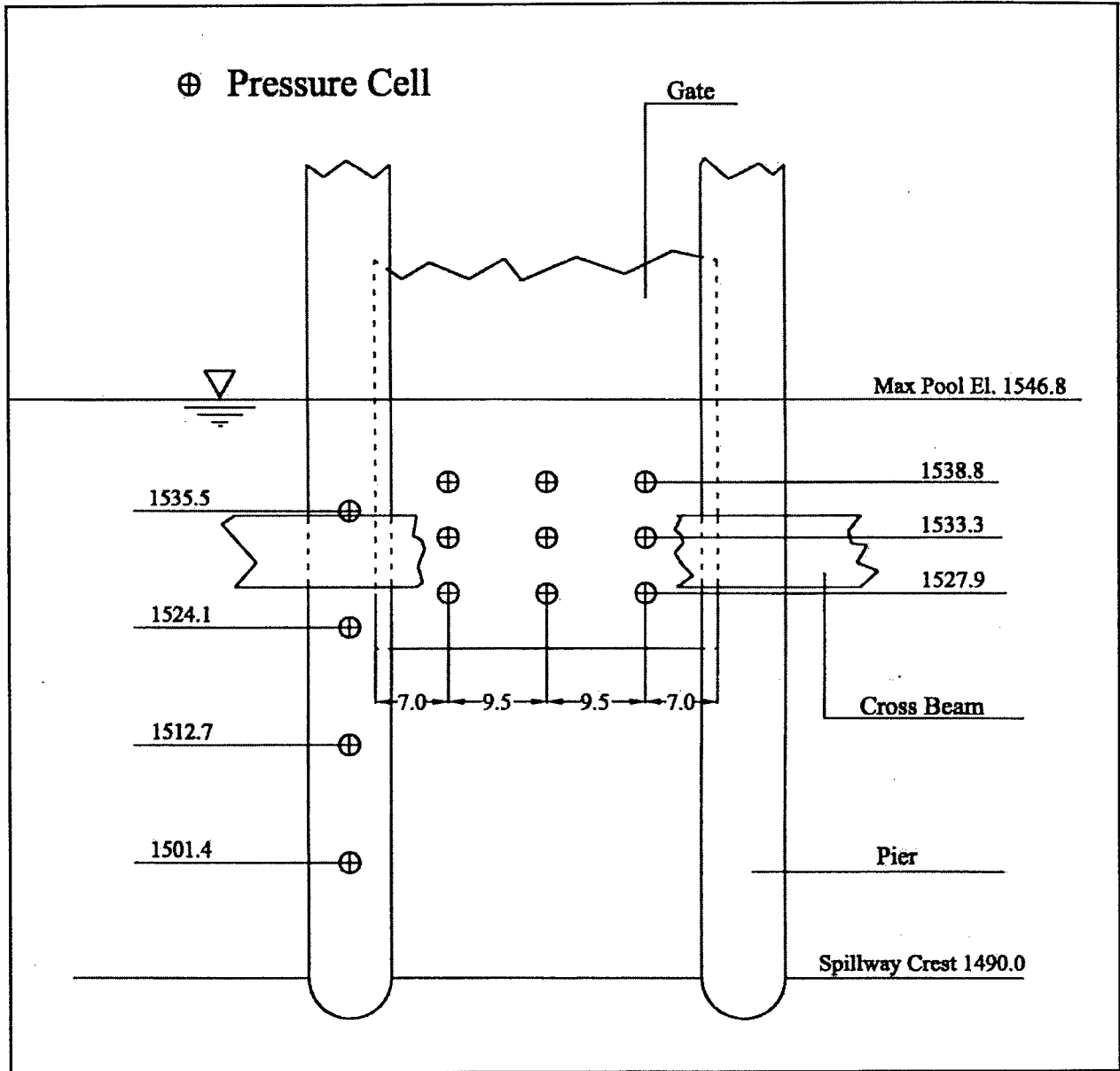

Figure 34. Spill gate and pier pressure cell locations, looking downstream

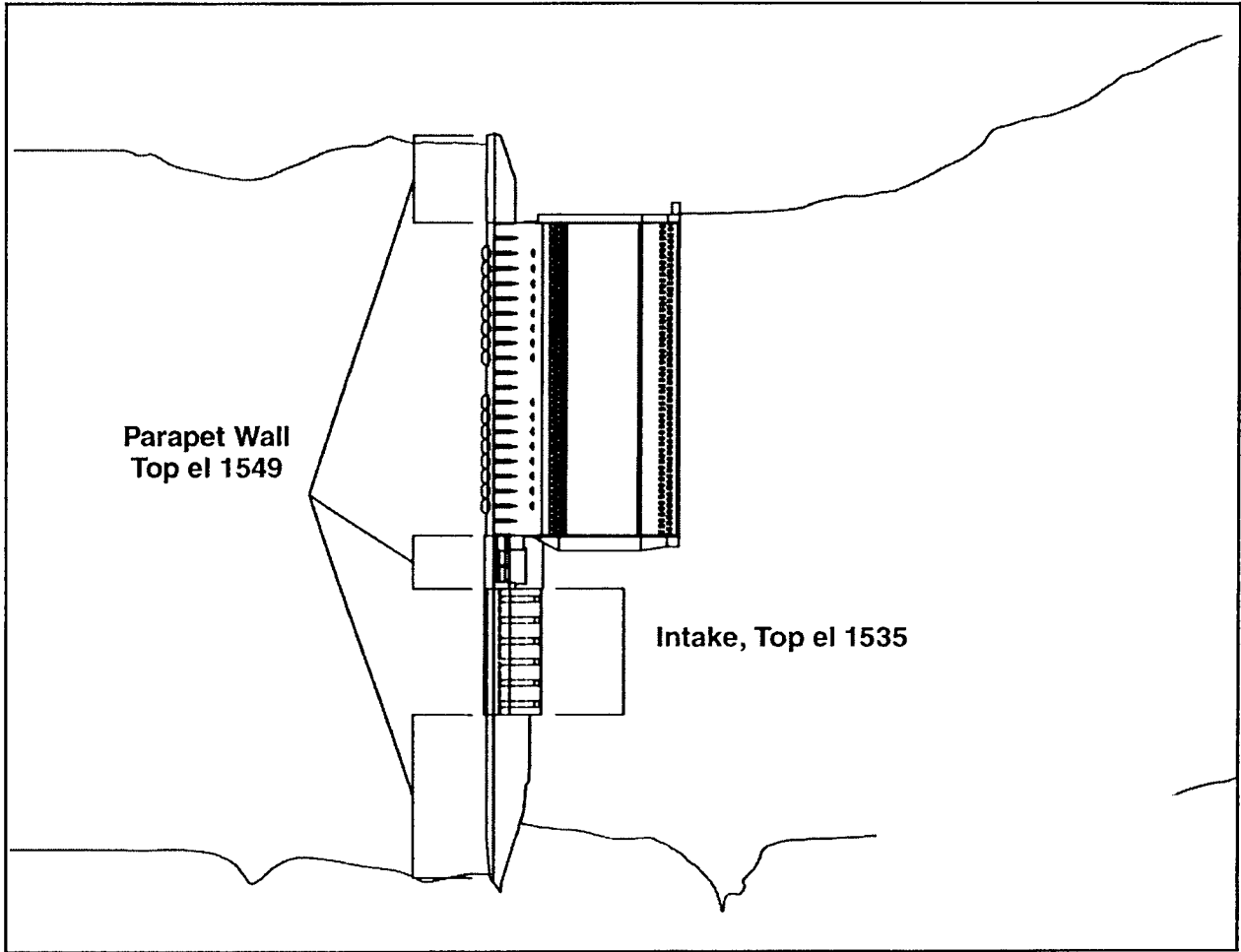

Figure 35. Layout of structures indicating overtopped (intake) section

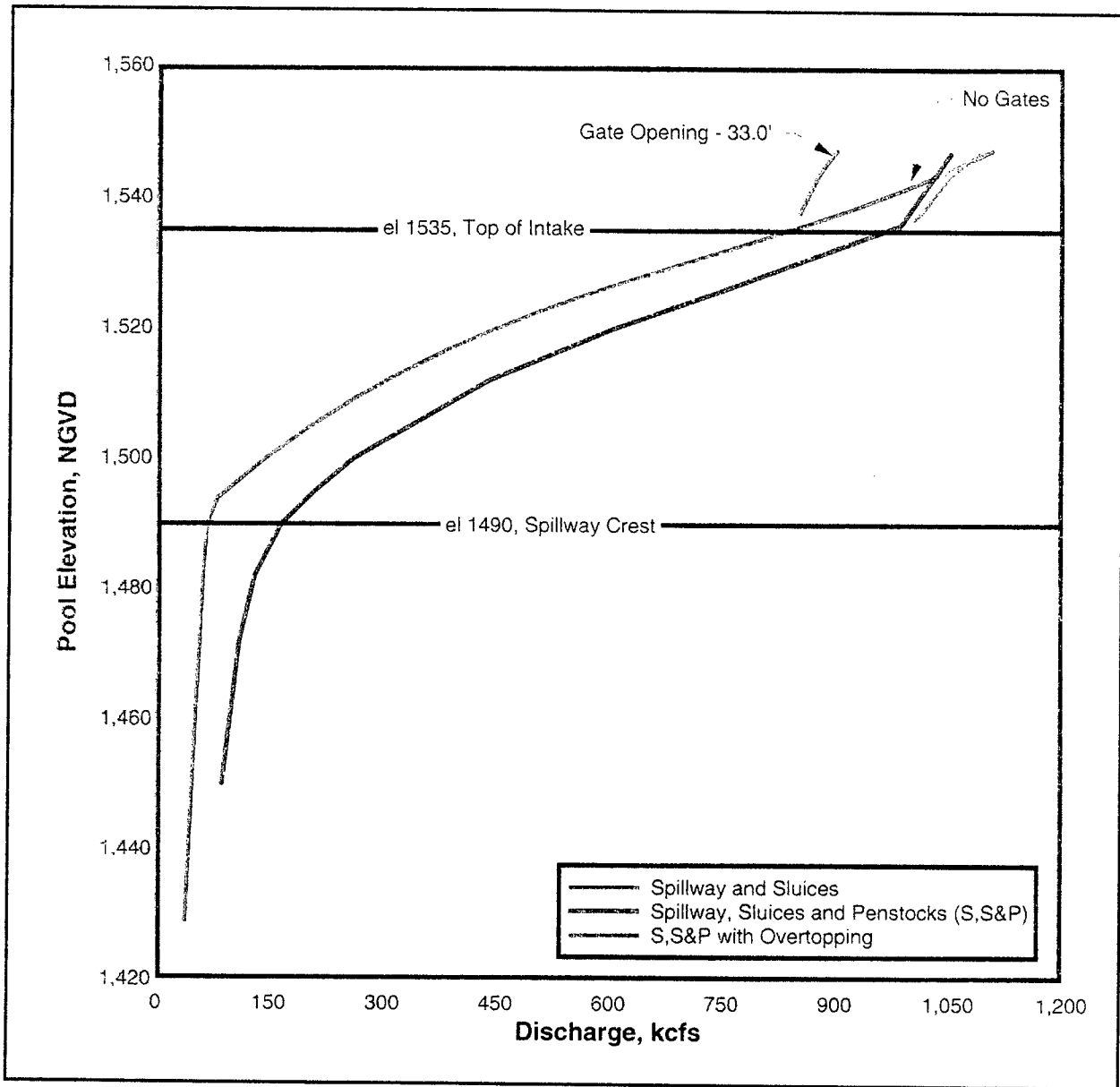

Figure 36. Extended rating curve, spillway, sluice, penstock, and overtopping discharge

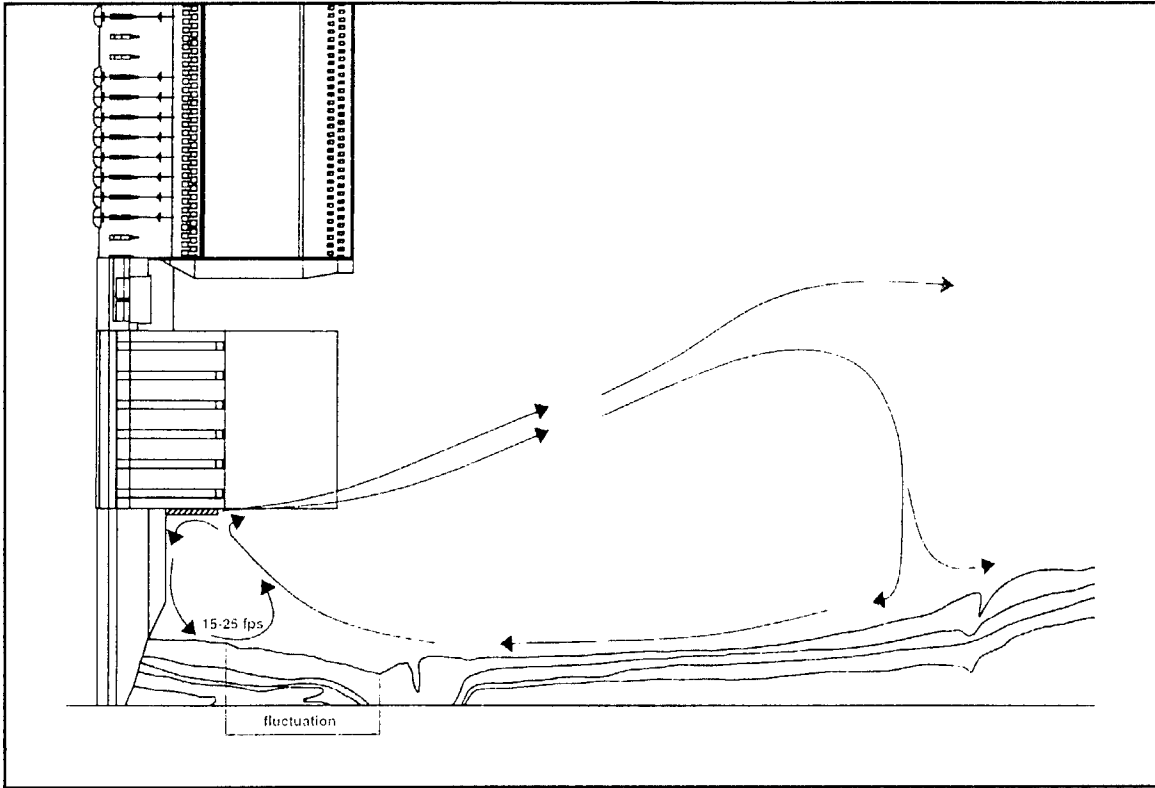

Figure 37. Eddy size and intensity with 100-ft-long training wall

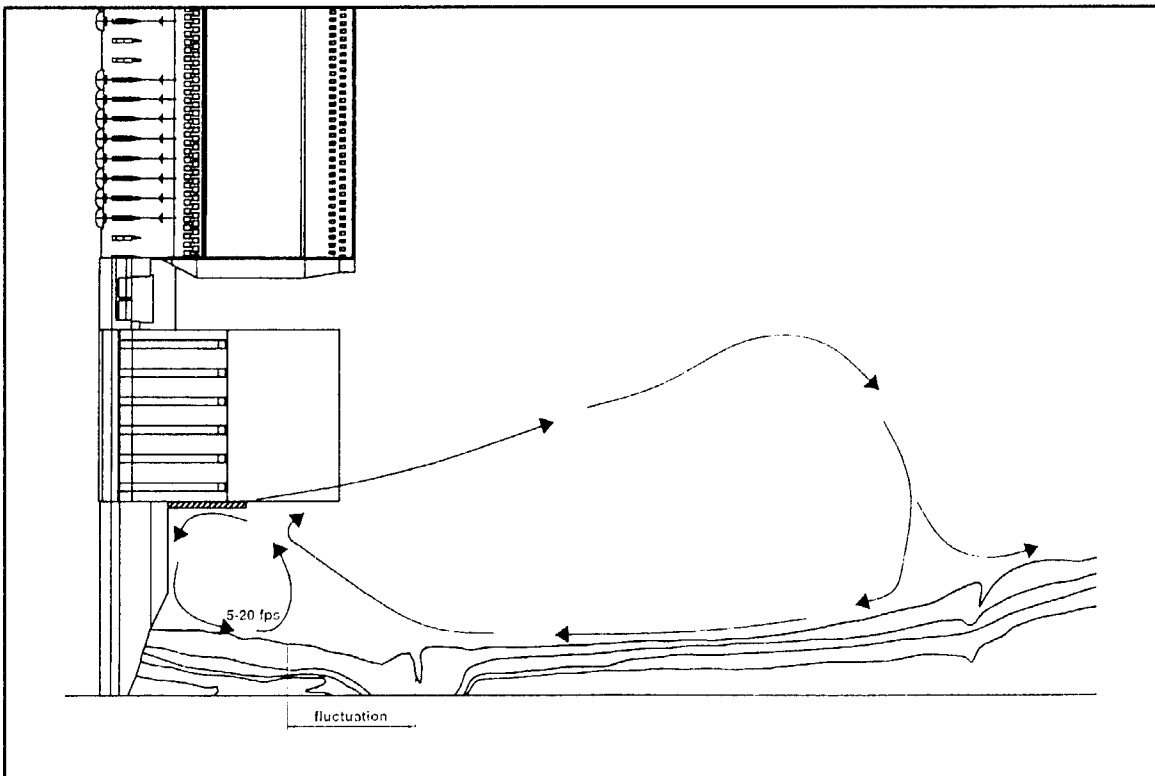

Figure 38. Eddy size and intensity with 150-ft-long training wall

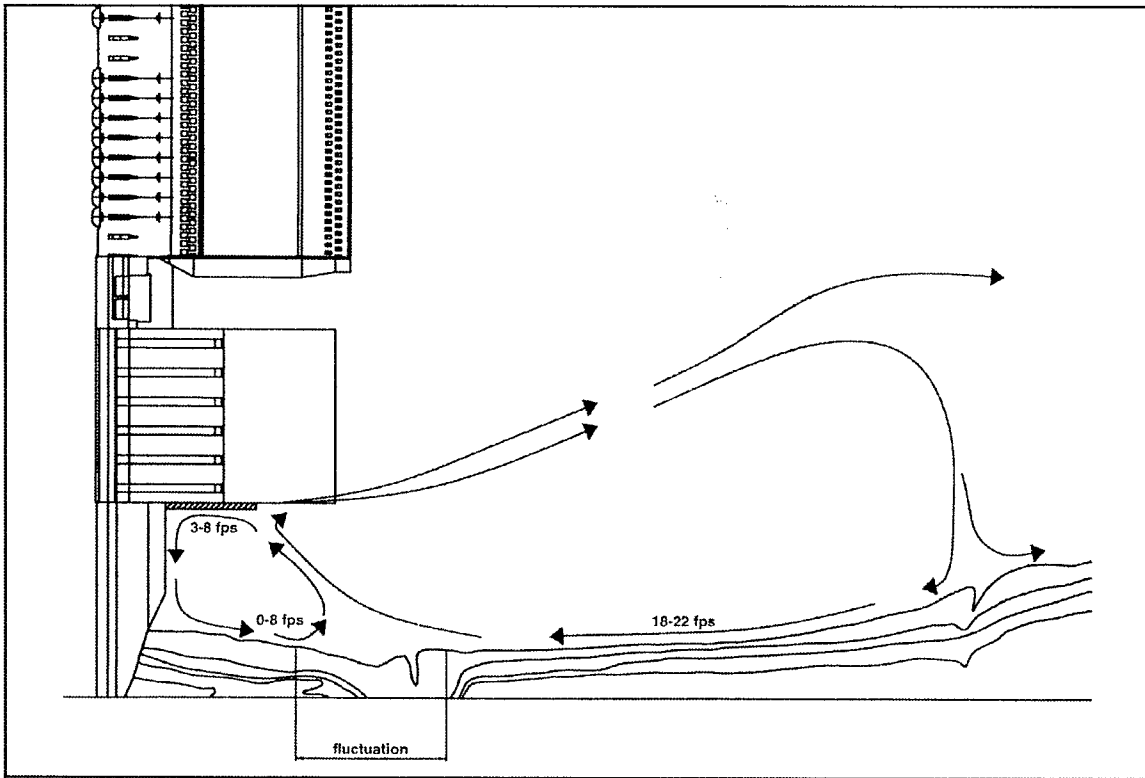

Figure 39. Eddy size and intensity with 175-ft-long training wall

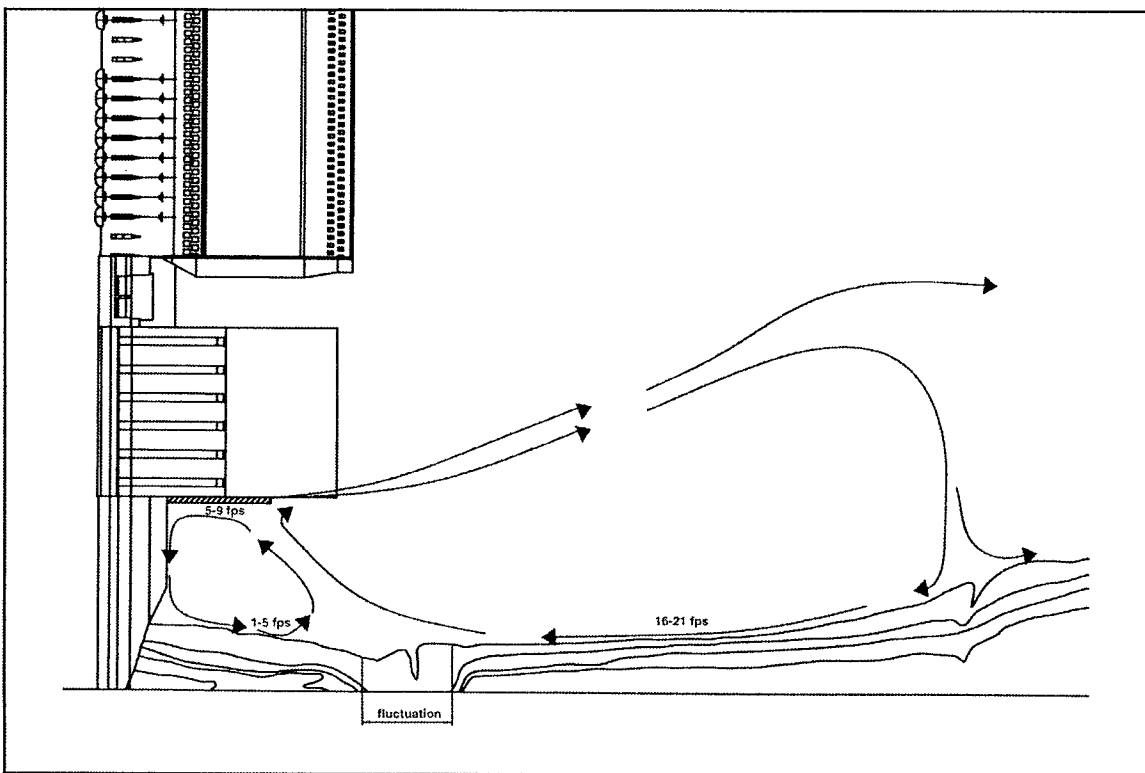

Figure 40. Eddy size and intensity with 200-ft-long training wall

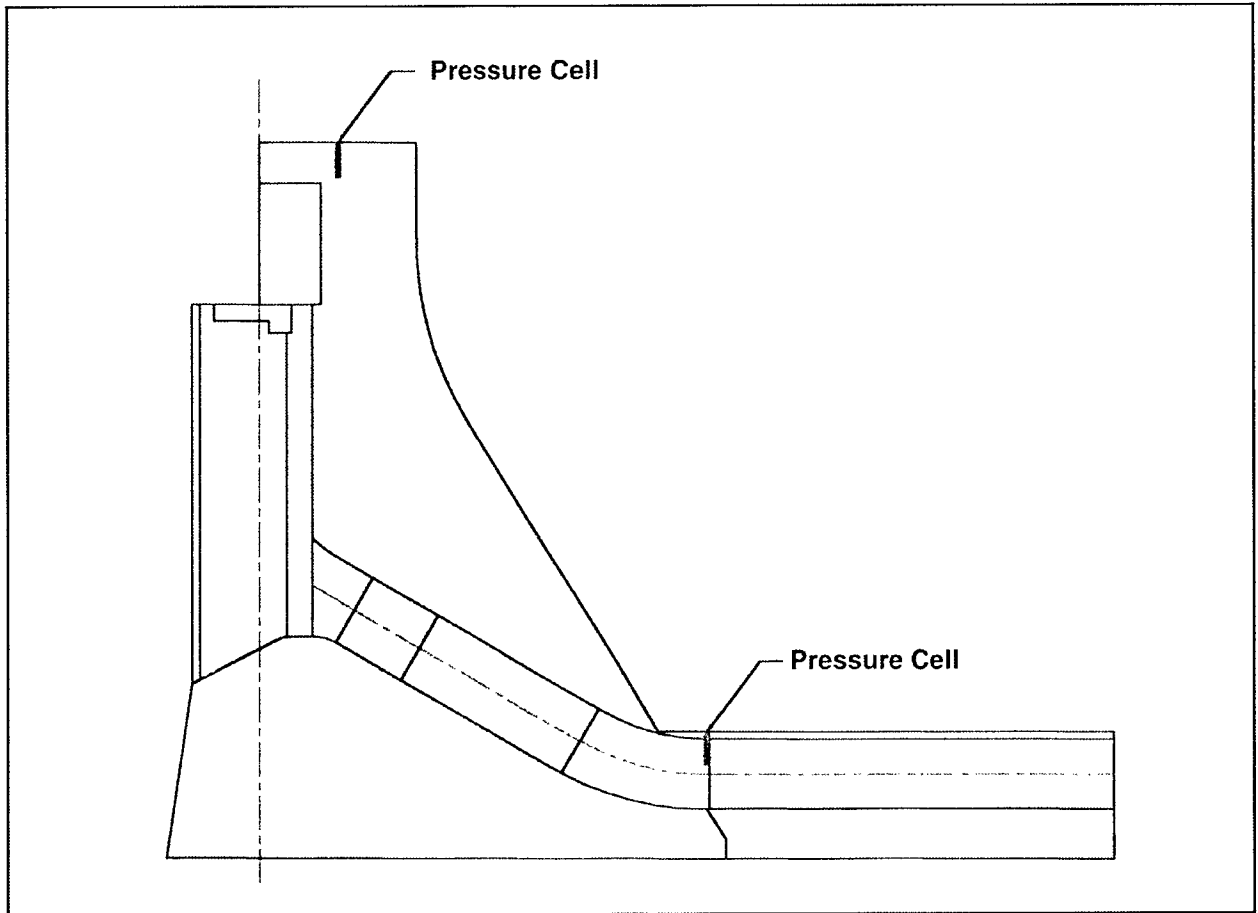

Figure 41. Overtopping study pressure cell locations

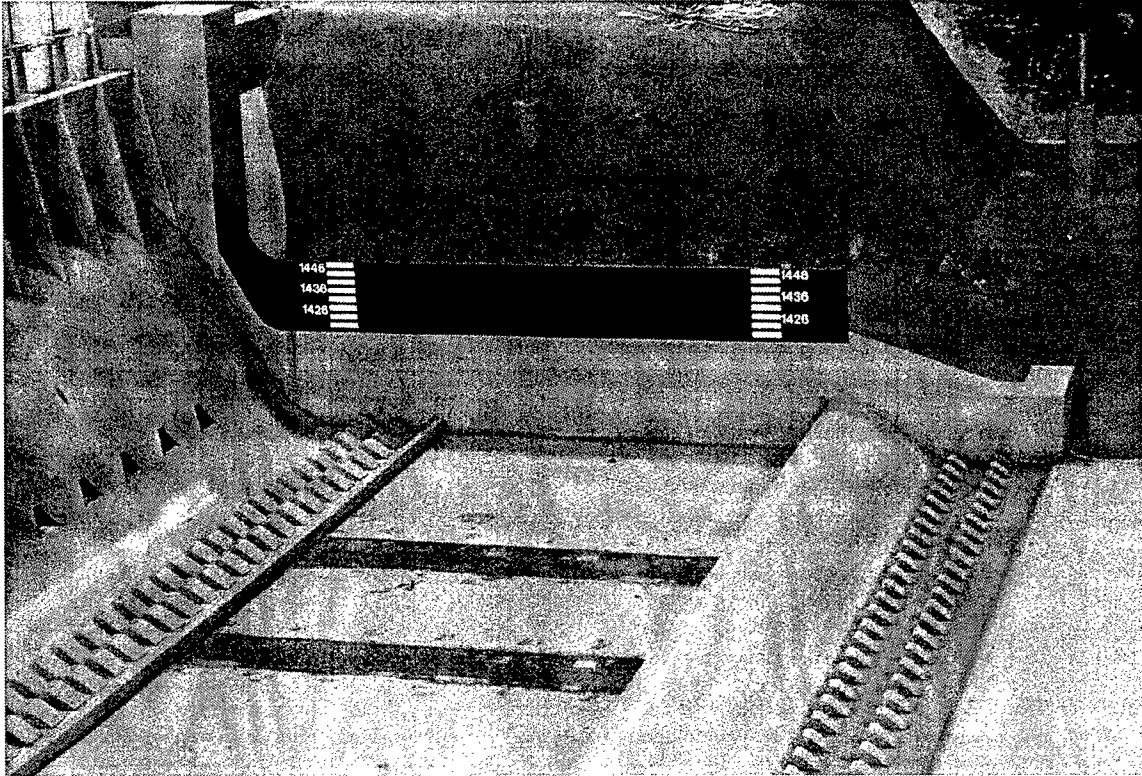

Photo 1. West training wall extension. Heights are shown in NGVD

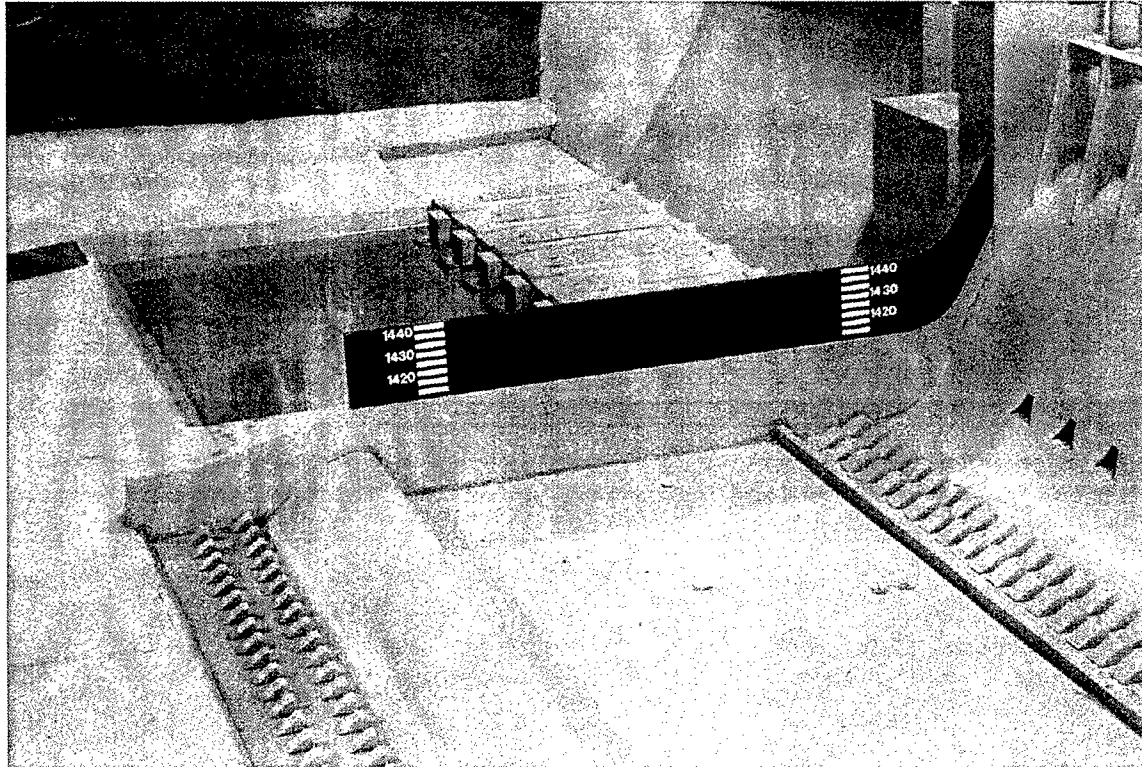

Photo 2. East training wall extension. Heights are shown in NGVD

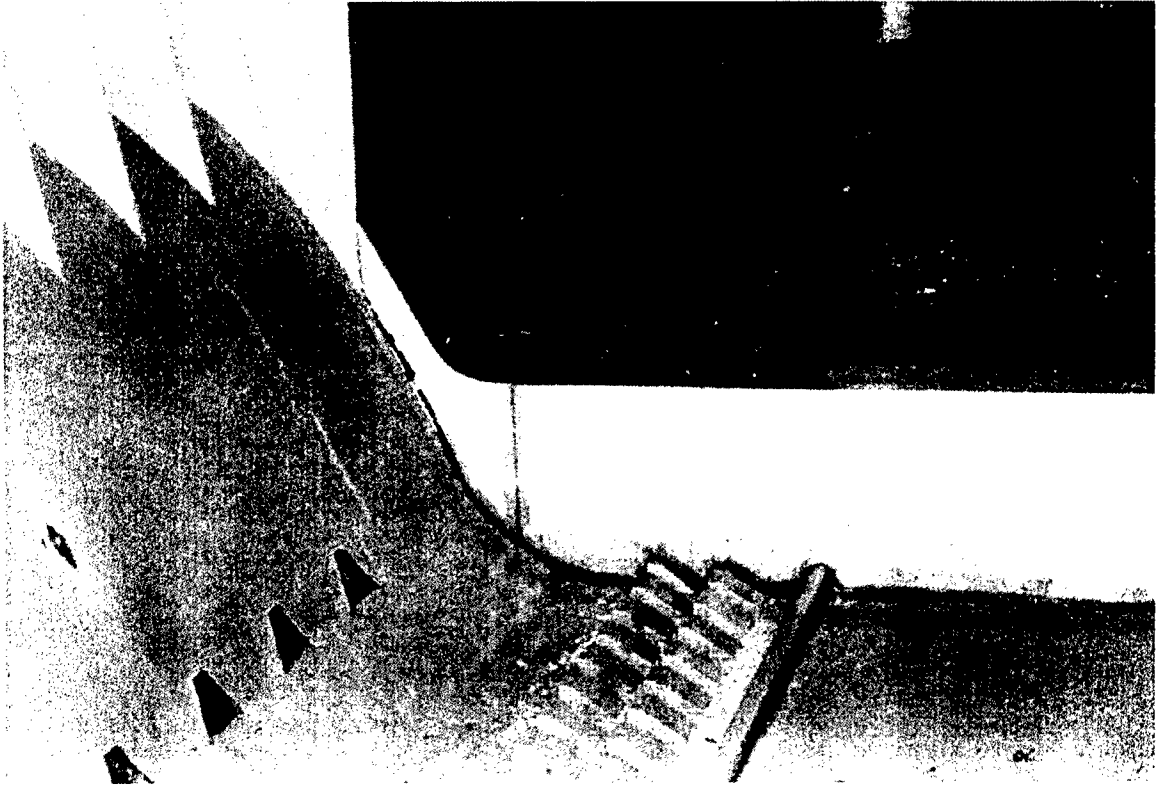

Photo 3. Final west training wall extension

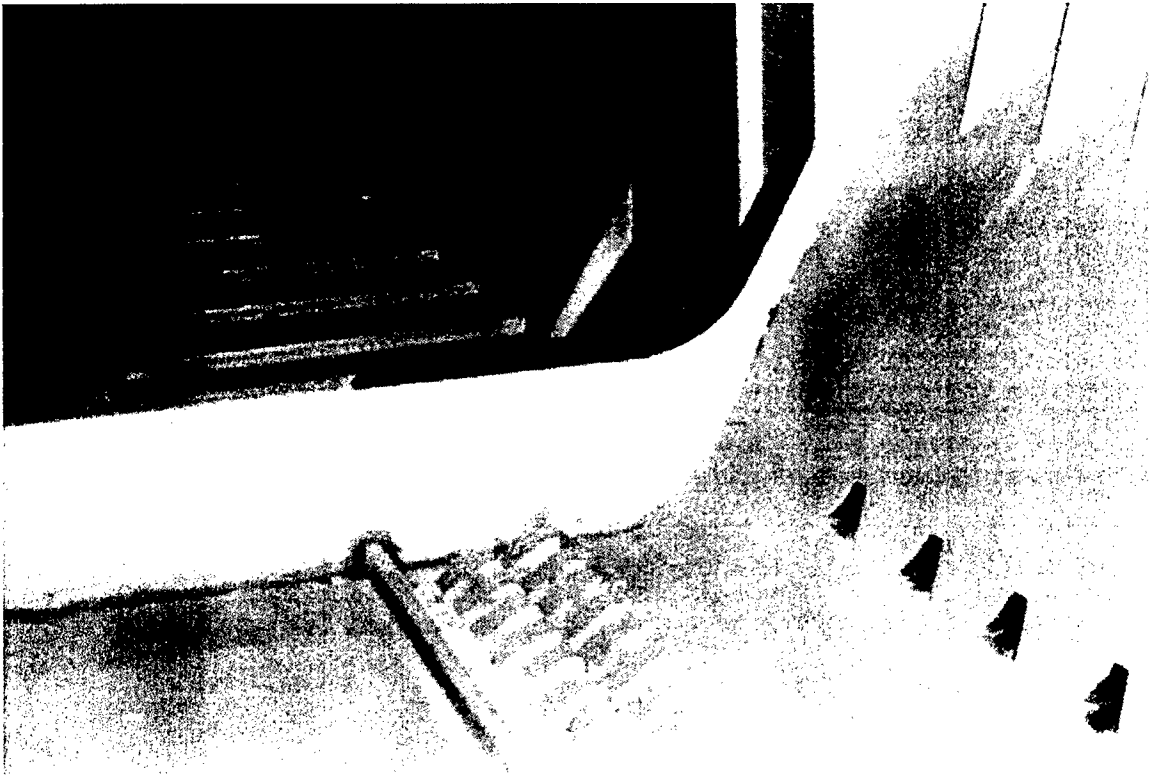
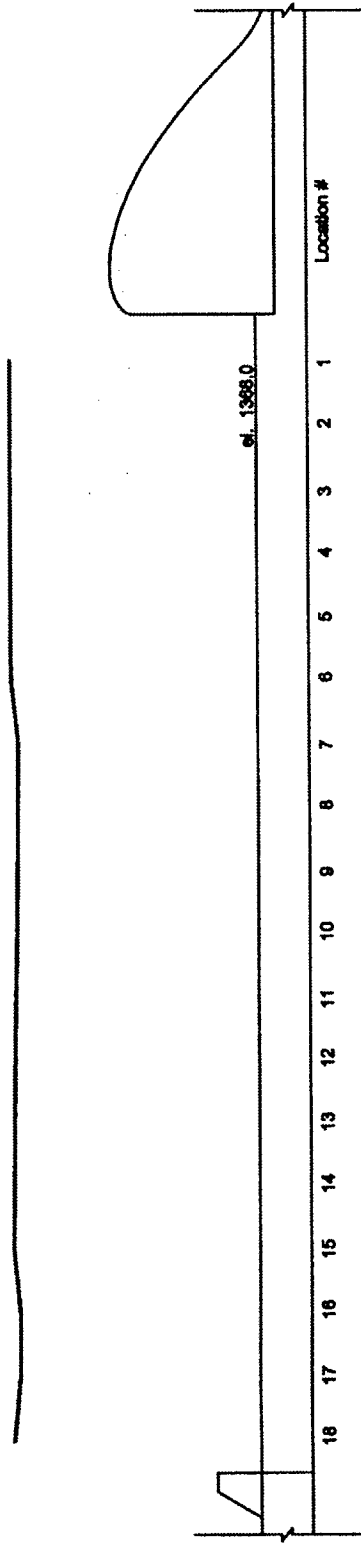

Photo 4. Final east training wall extension

Appendix A Piezometric Pressure Data, Stilling Basin



Location Number	Distance from CL of Dam, ft	Pressure, ft of water	Location Number	Distance from CL of Dam, ft	Pressure, ft of water
18	175	1407	9	265	1406
17	185	1406	8	275	1406
16	195	1406	7	285	1406
15	205	1407	6	295	1407
14	215	1406	5	305	1407
13	225	1406	4	315	1407
12	235	1406	3	325	1407
11	245	1406	2	335	1407
10	255	1406	1	345	1407

Bluestone General Model

Condition Number 4
 Stilling Basin Pressures
 Piezometer Measurements
 Downstream of Spillbay 5

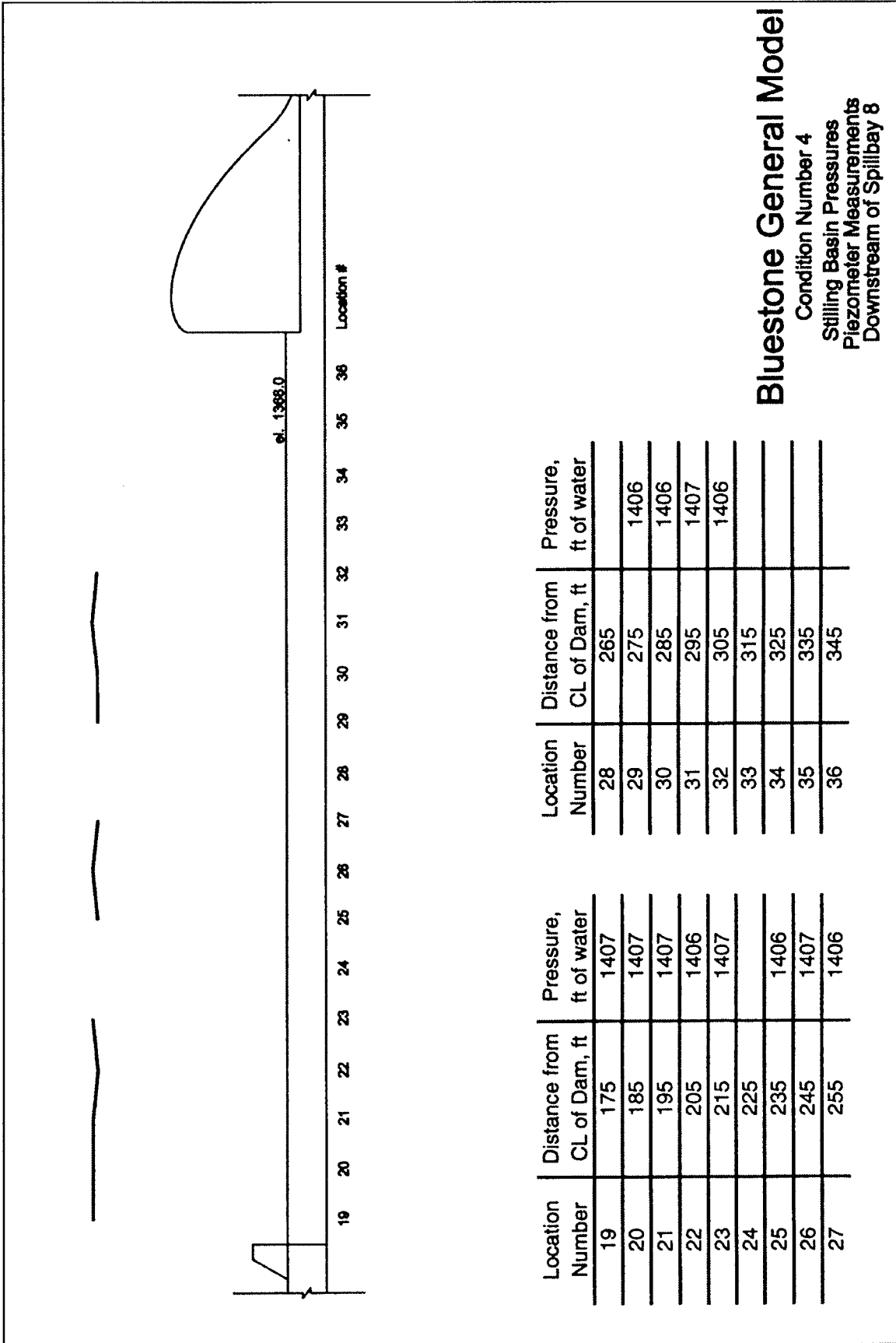

Bluestone General Model
 Condition Number 4
 Stilling Basin Pressures
 Piezometer Measurements
 Downstream of Spillbay 8

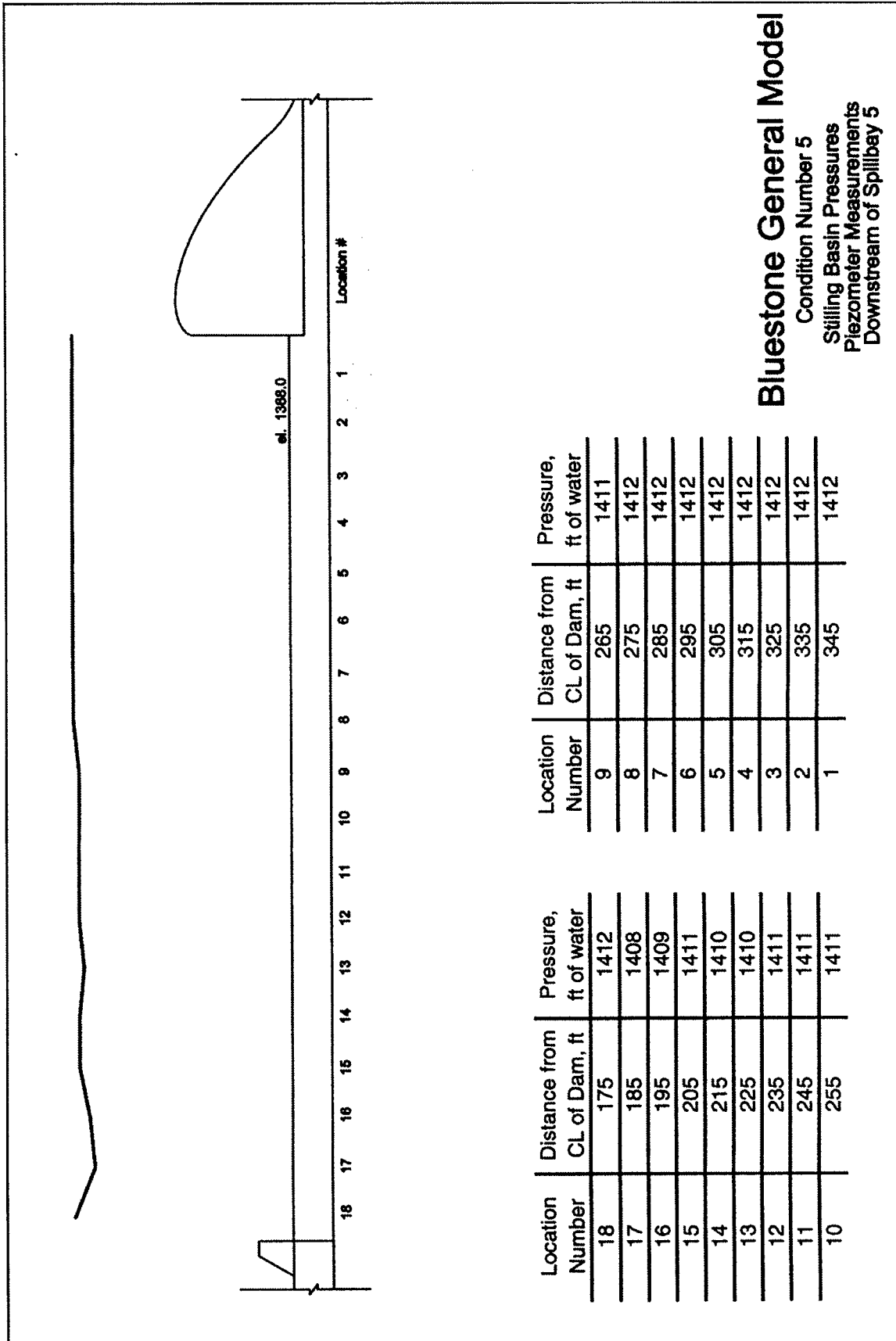

Bluestone General Model
 Condition Number 5
 Stilling Basin Pressures
 Piezometer Measurements
 Downstream of Spillbay 5

Location Number	Distance from CL of Dam, ft	Pressure, ft of water	Location Number	Distance from CL of Dam, ft	Pressure, ft of water
18	175	1412	9	265	1411
17	185	1408	8	275	1412
16	195	1409	7	285	1412
15	205	1411	6	295	1412
14	215	1410	5	305	1412
13	225	1410	4	315	1412
12	235	1411	3	325	1412
11	245	1411	2	335	1412
10	255	1411	1	345	1412

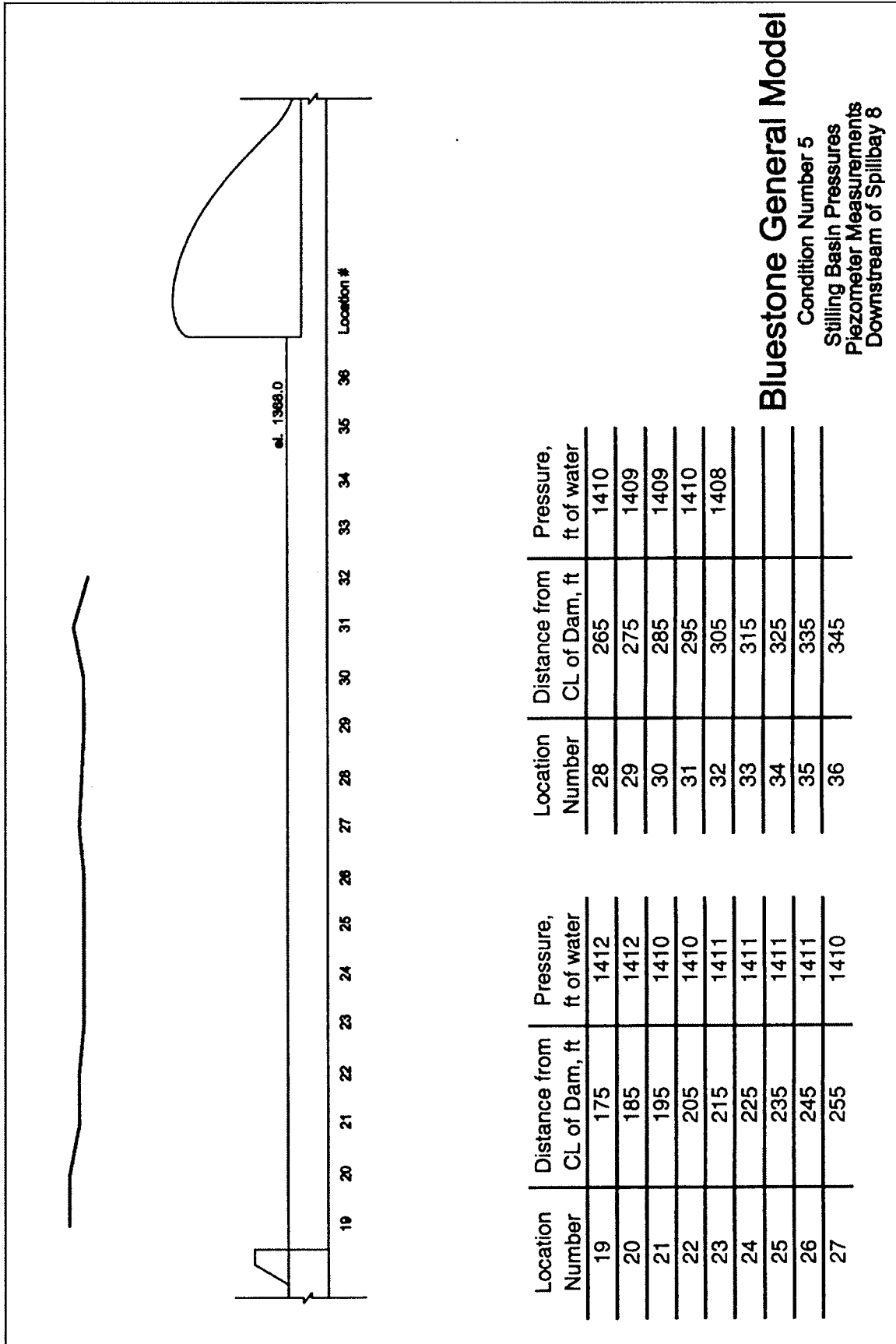

Location Number	Distance from CL of Dam, ft	Pressure, ft of water	Location Number	Distance from CL of Dam, ft	Pressure, ft of water
19	175	1412	28	265	1410
20	185	1412	29	275	1409
21	195	1410	30	285	1409
22	205	1410	31	295	1410
23	215	1411	32	305	1408
24	225	1411	33	315	
25	235	1411	34	325	
26	245	1411	35	335	
27	255	1410	36	345	

Bluestone General Model

Condition Number 5
 Stilling Basin Pressures
 Piezometer Measurements
 Downstream of Spillbay 8

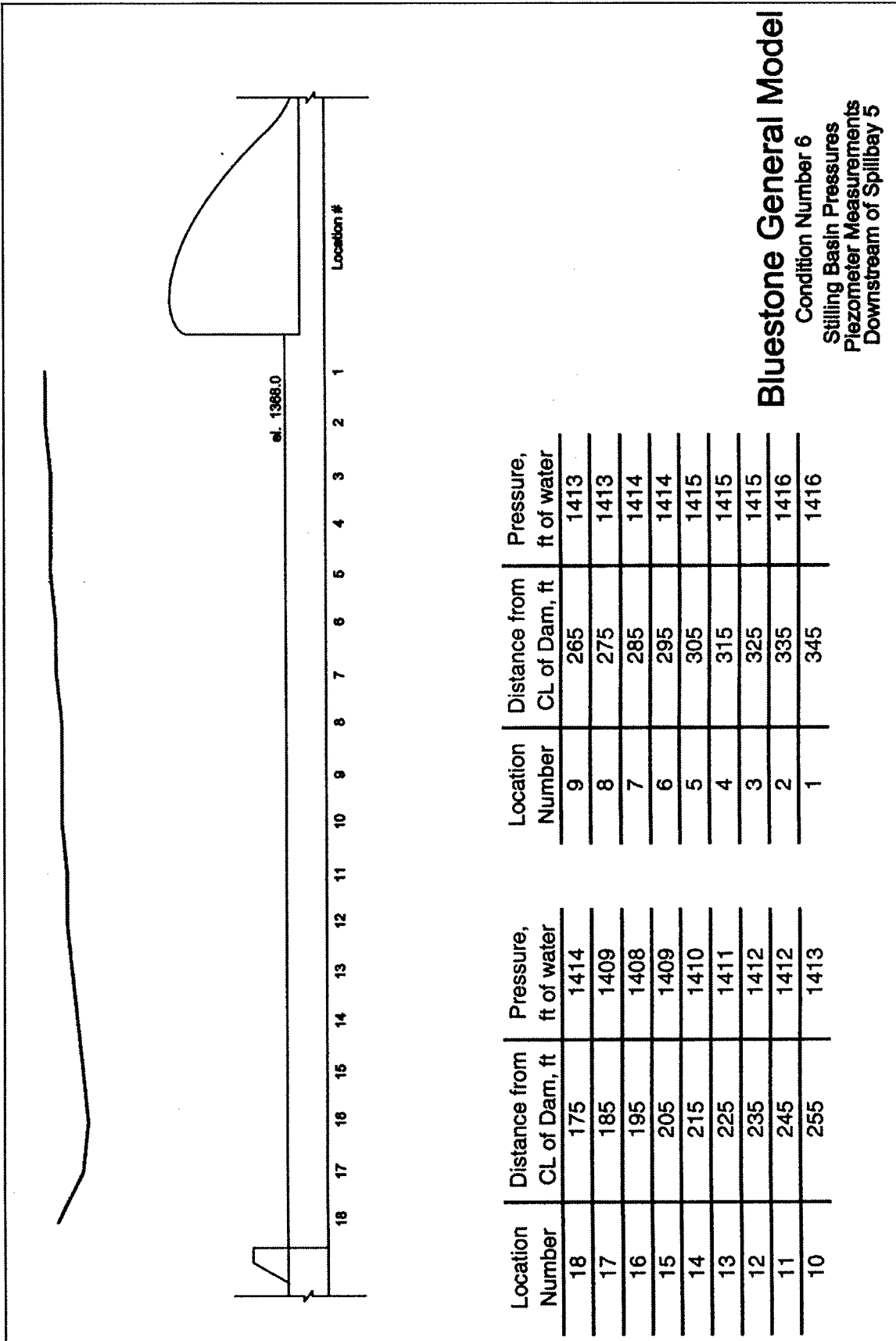

Bluestone General Model
 Condition Number 6
 Stilling Basin Pressures
 Piezometer Measurements
 Downstream of Spillbay 5

Location Number	Distance from CL of Dam, ft	Pressure, ft of water	Location Number	Distance from CL of Dam, ft	Pressure, ft of water
18	175	1414	9	265	1413
17	185	1409	8	275	1413
16	195	1408	7	285	1414
15	205	1409	6	295	1414
14	215	1410	5	305	1415
13	225	1411	4	315	1415
12	235	1412	3	325	1415
11	245	1412	2	335	1416
10	255	1413	1	345	1416

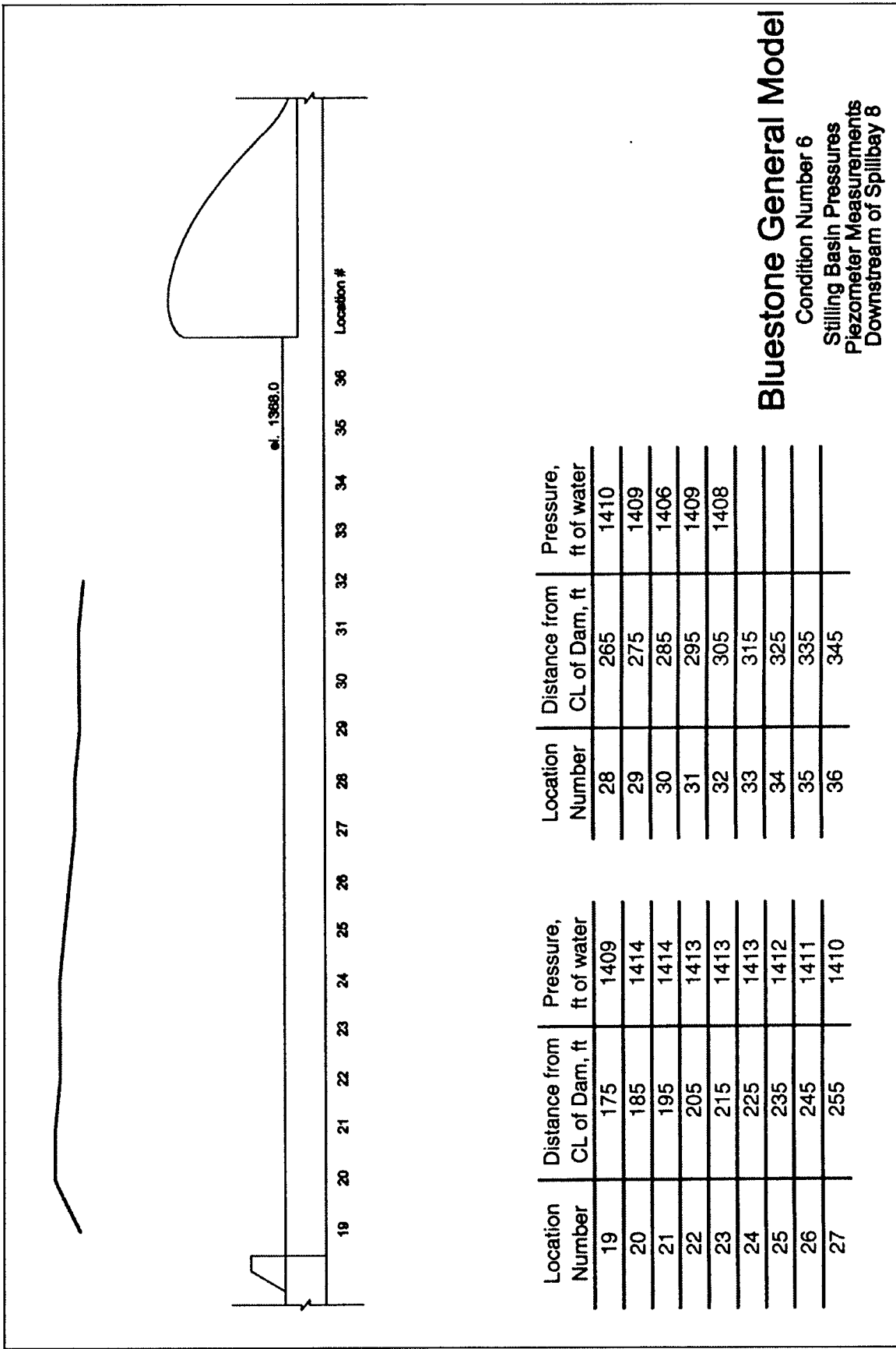

Bluestone General Model
 Condition Number 6
 Stilling Basin Pressures
 Piezometer Measurements
 Downstream of Spillbay 8

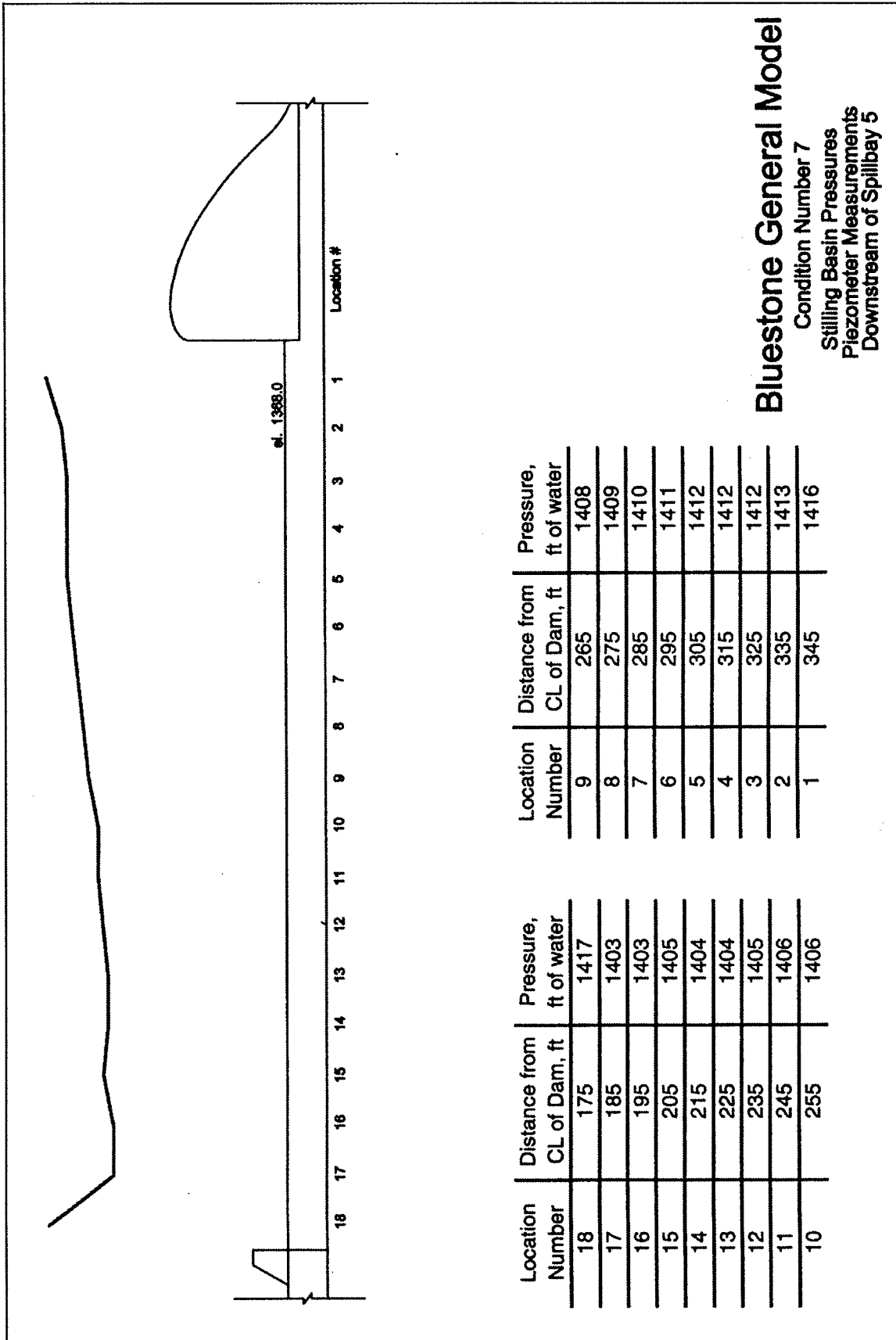

Bluestone General Model
 Condition Number 7
 Stilling Basin Pressures
 Piezometer Measurements
 Downstream of Spillbay 5

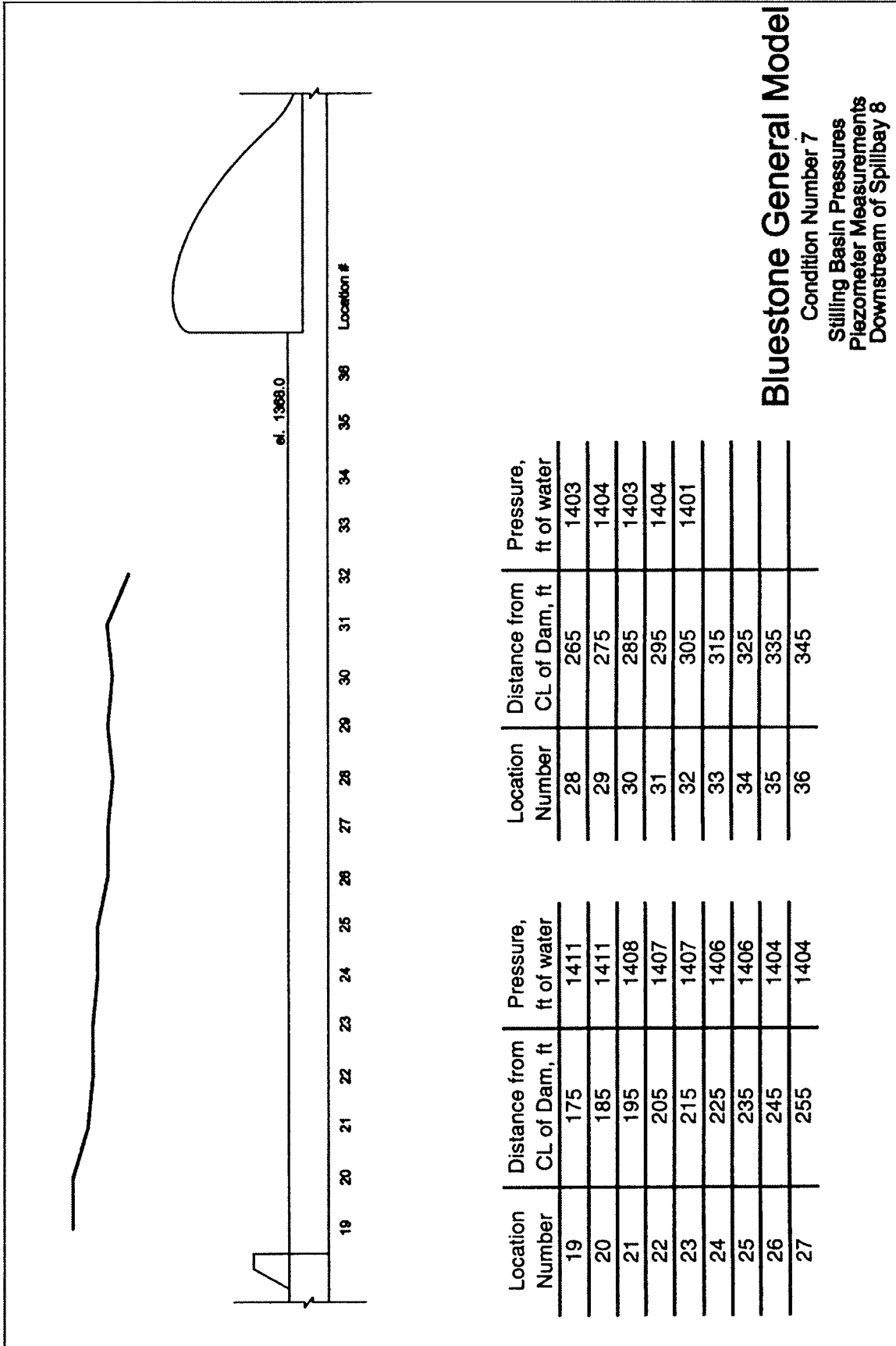

Bluestone General Model

Condition Number 7
 Stilling Basin Pressures
 Piezometer Measurements
 Downstream of Spillbay 8

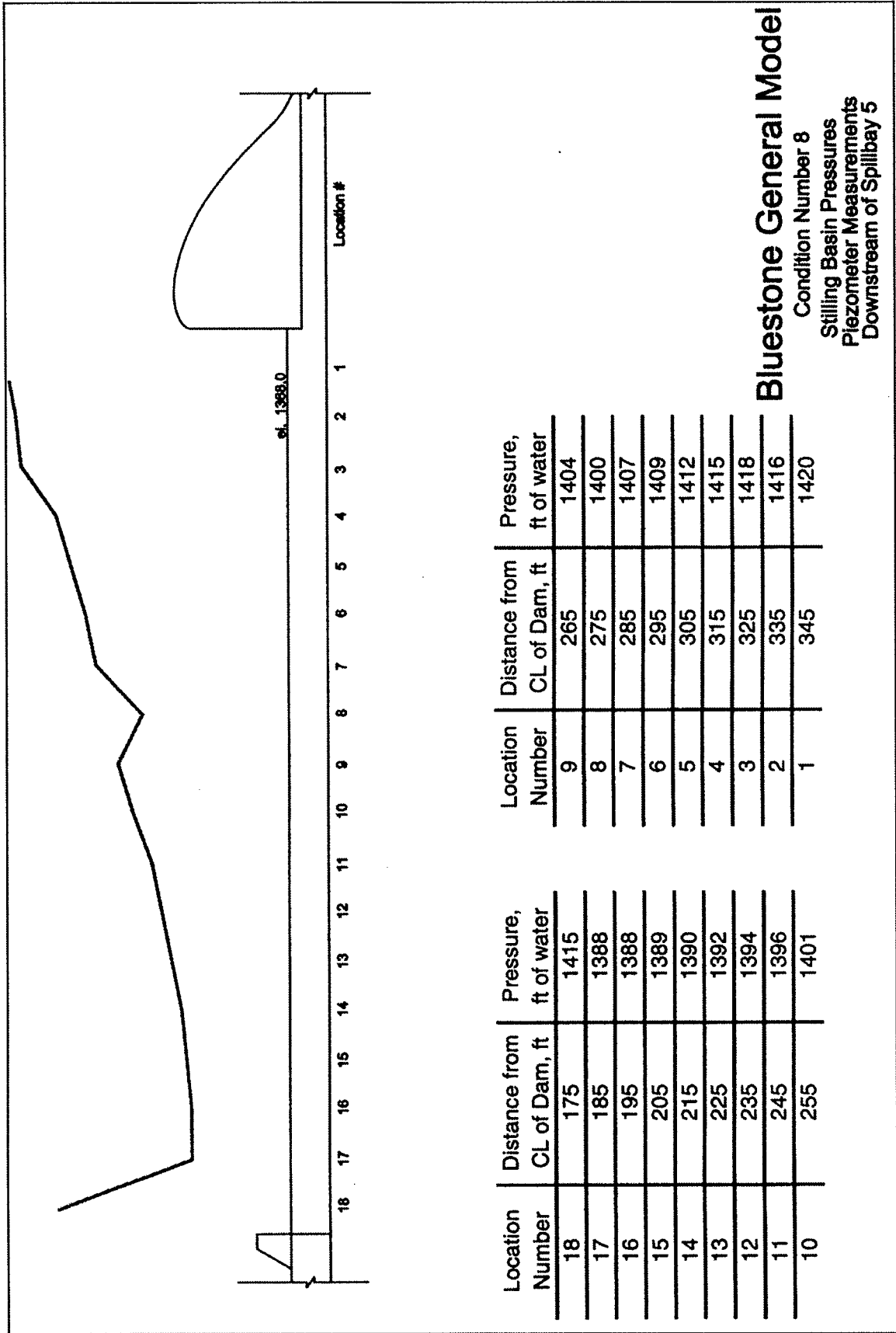

Bluestone General Model
 Condition Number 8
 Stilling Basin Pressures
 Piezometer Measurements
 Downstream of Spillbay 5

Location Number	Distance from CL of Dam, ft	Pressure, ft of water	Location Number	Distance from CL of Dam, ft	Pressure, ft of water
18	175	1415	9	265	1404
17	185	1388	8	275	1400
16	195	1388	7	285	1407
15	205	1389	6	295	1409
14	215	1390	5	305	1412
13	225	1392	4	315	1415
12	235	1394	3	325	1418
11	245	1396	2	335	1416
10	255	1401	1	345	1420

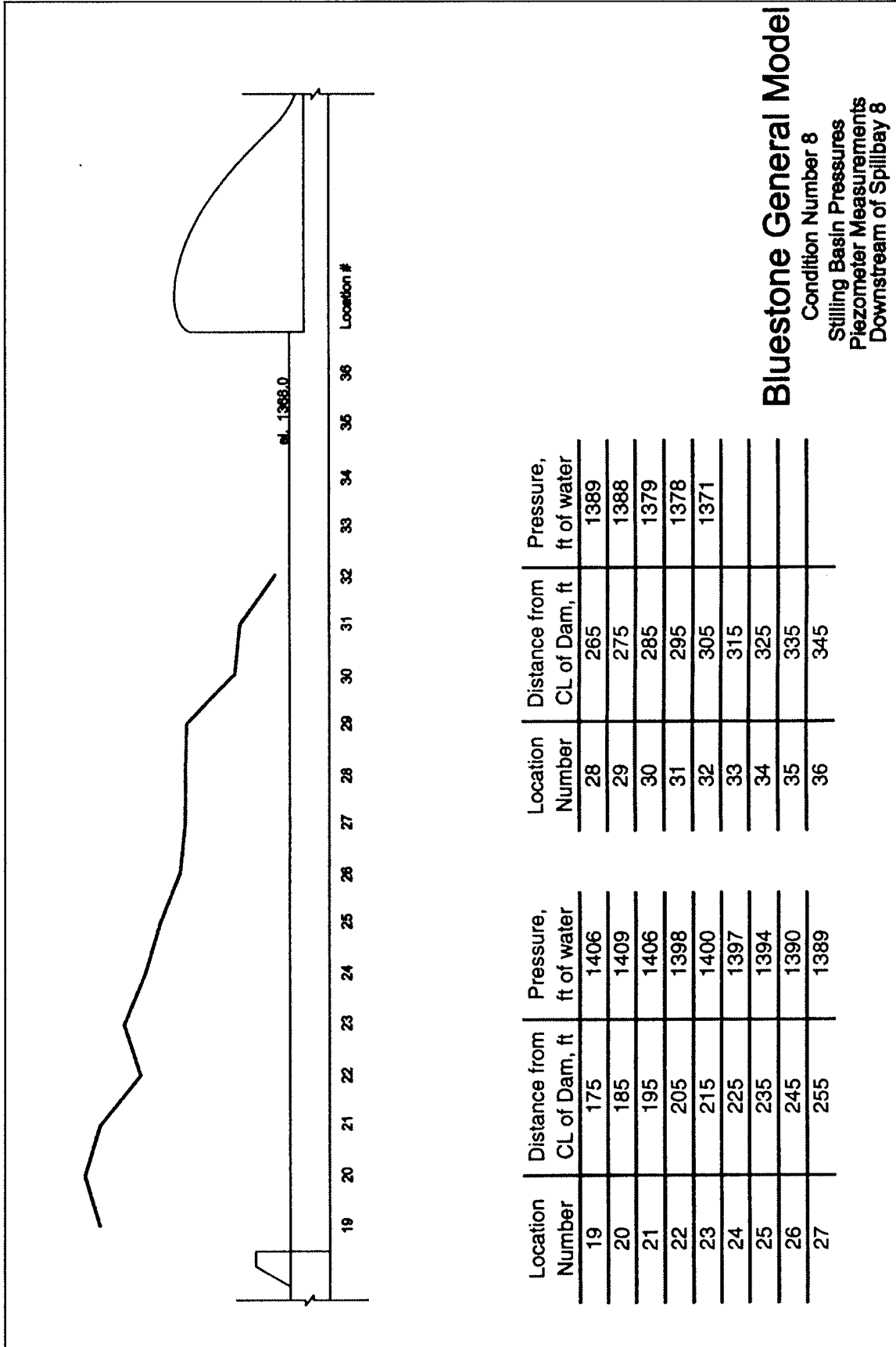
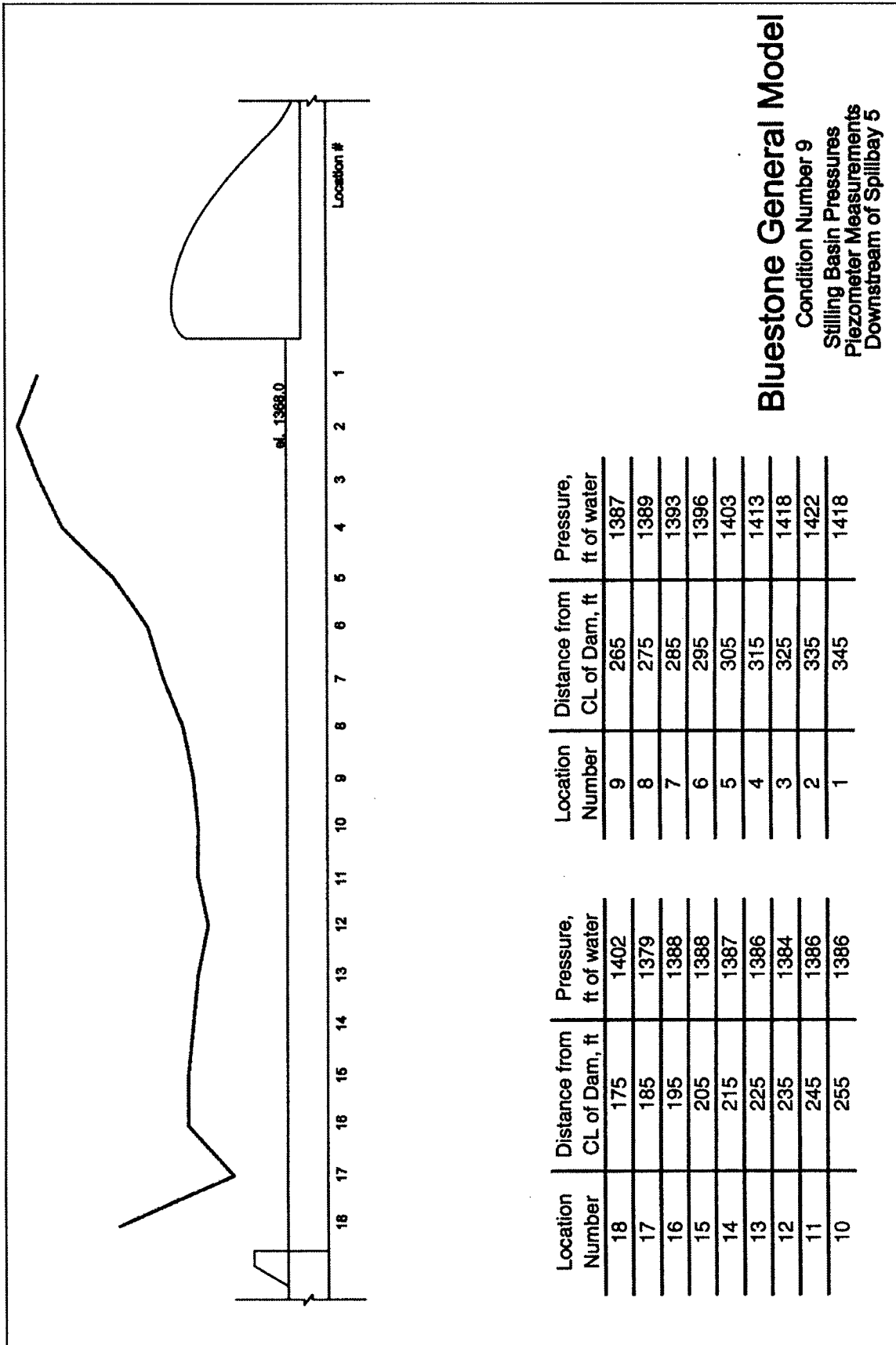

PLATE A10

Location Number	Distance from CL of Dam, ft	Pressure, ft of water
28	265	1389
29	275	1388
30	285	1379
31	295	1378
32	305	1371
33	315	
34	325	
35	335	
36	345	

Location Number	Distance from CL of Dam, ft	Pressure, ft of water
19	175	1406
20	185	1409
21	195	1406
22	205	1398
23	215	1400
24	225	1397
25	235	1394
26	245	1390
27	255	1389

Bluestone General Model
 Condition Number 8
 Stilling Basin Pressures
 Piezometer Measurements
 Downstream of Spillbay 8



Bluestone General Model
 Condition Number 9
 Stilling Basin Pressures
 Piezometer Measurements
 Downstream of Spillbay 5

Location Number	Distance from CL of Dam, ft	Pressure, ft of water
9	265	1387
8	275	1389
7	285	1393
6	295	1396
5	305	1403
4	315	1413
3	325	1418
2	335	1422
1	345	1418

Location Number	Distance from CL of Dam, ft	Pressure, ft of water
18	175	1402
17	185	1379
16	195	1388
15	205	1388
14	215	1387
13	225	1386
12	235	1384
11	245	1386
10	255	1386

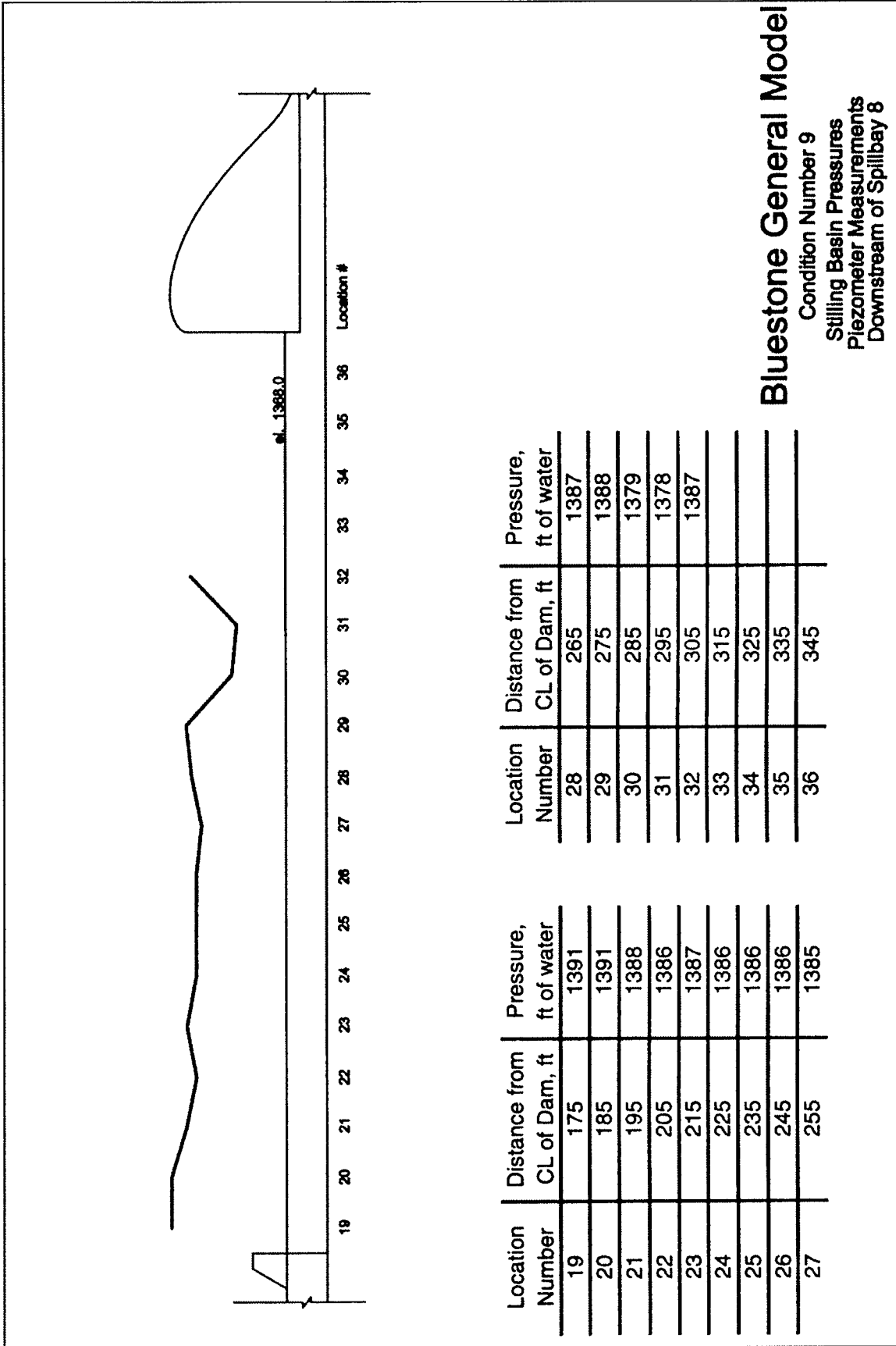

Bluestone General Model

Condition Number 9
 Stilling Basin Pressures
 Piezometer Measurements
 Downstream of Spillbay 8

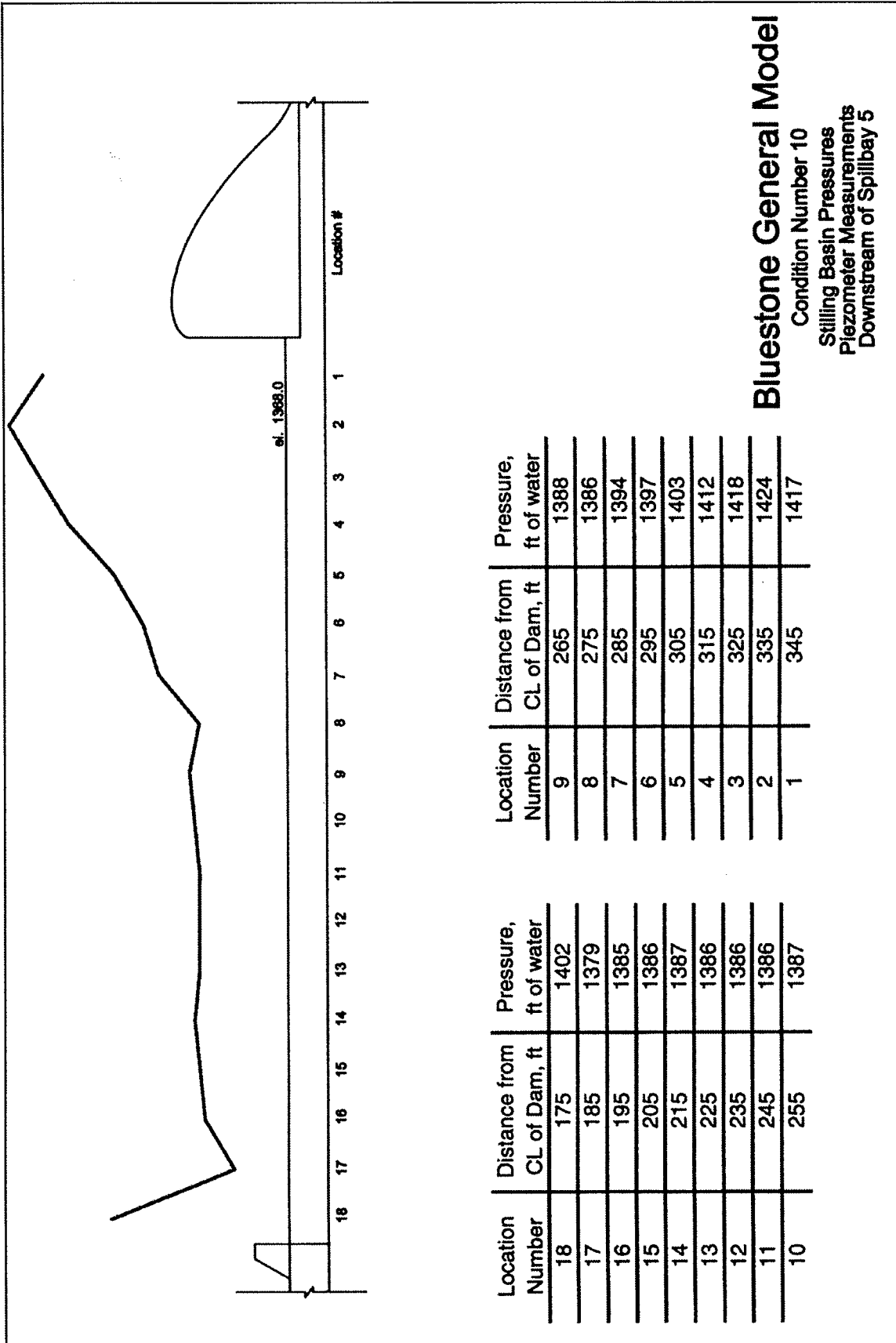

Bluestone General Model
 Condition Number 10
 Stilling Basin Pressures
 Piezometer Measurements
 Downstream of Spillbay 5

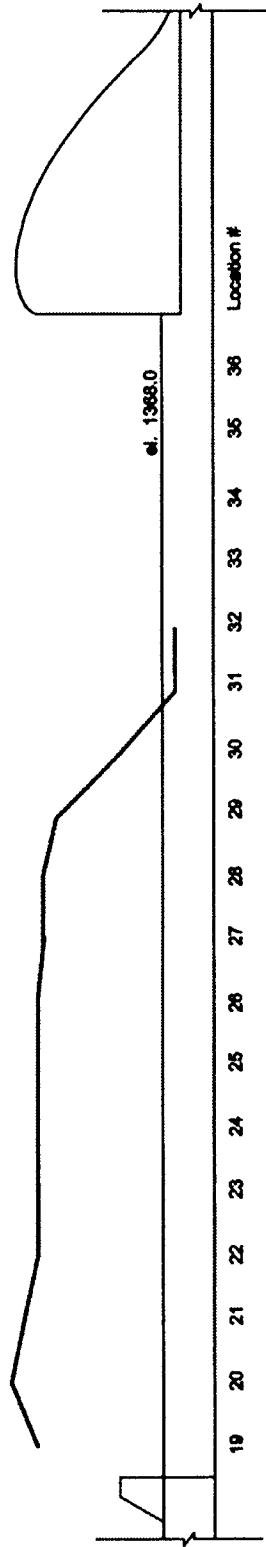

Location Number	Distance from CL of Dam, ft	Pressure, ft of water	Location Number	Distance from CL of Dam, ft	Pressure, ft of water
19	175	1388	28	265	1386
20	185	1392	29	275	1385
21	195	1390	30	285	1375
22	205	1387	31	295	1366
23	215	1387	32	305	1366
24	225	1387	33	315	
25	235	1387	34	325	
26	245	1387	35	335	
27	255	1386	36	345	

Bluestone General Model

Condition Number 10
 Stilling Basin Pressures
 Piezometer Measurements
 Downstream of Spillbay 8

Appendix B Pressure Cell Data, Stilling Basin

Information File Name: c:\wesdaq1\C4-1.inf
 Sample Rate: 50.000 samples/sec/channel
 Number of Seconds Recorded: 180.000 seconds
 Data Collected on 6/2/00 2:17:54 PM
 Bluestone Dam Model
 1:65 Scale
 Condition No. 4: Pool Elevation = 1504.7 Ft. Prototype
 All 6 channels filtered at 10 Hz. Low Pass
 All Calibrations and Data Recorded are in Prototype feet
 All channels are balanced and calibrated at 23.0 Ft. Prototype,
 Model Water Level at top of Stilling Weir.

ISDD Operator: Wallace Guy

STATISTICS						
CHAN	MINIMUM	AVERAGE	MAXIMUM	STANDARD	ROOT MEAN	ENGINEERING UNI
NUM	MEASUREMENT	MEASUREMENT	MEASUREMENT	DEVIATION	SQUARE	
1	13.122	28.175	47.093	4.149	28.479	PROTO-FT
2	-73.957	-28.575	33.557	14.689	32.129	PROTO-FT
3	14.445	26.451	41.062	3.540	26.686	PROTO-FT
4	-30.081	-1.119	36.558	9.532	9.597	PROTO-FT
5	-57.782	-27.618	7.453	9.696	29.271	PROTO-FT
6	-23.352	5.726	44.136	9.894	11.431	PROTO-FT

CALIBRATION INFORMATION							
CHAN	GAIN	BASE	CALSTEP	BASE	CAL STEP	ENGINEERING UNITS	TYPE OF G
NUM		VOLTAGE	VOLTAGE	ENG VALUE	ENG VALUE		
1	1.0	-0.005	2.010	23.000	51.199	PROTO-FT	5-2
2	1.0	0.008	1.044	23.000	50.701	PROTO-FT	5-11
3	1.0	0.011	2.009	23.000	48.036	PROTO-FT	5-18
4	1.0	0.013	1.463	23.000	44.900	PROTO-FT	8-2
5	1.0	0.003	1.067	23.000	51.205	PROTO-FT	8-11
6	1.0	-0.010	1.835	23.000	58.566	PROTO-FT	8-18

C:\WESDAQ1\BLUSTONE\C4-1, Channel Number 1

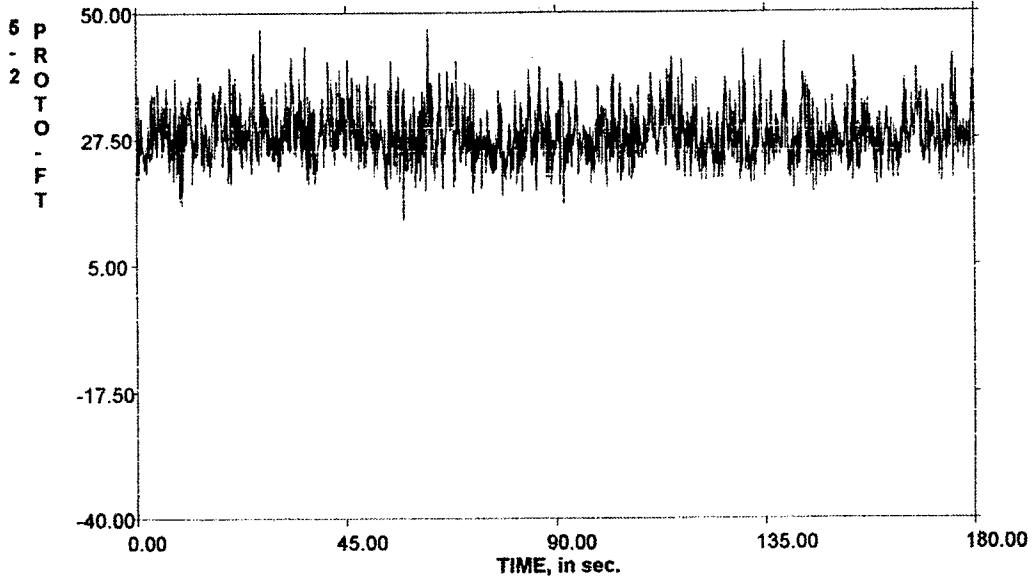

C:\WESDAQ1\BLUSTONE\C4-1, Channel Number 4

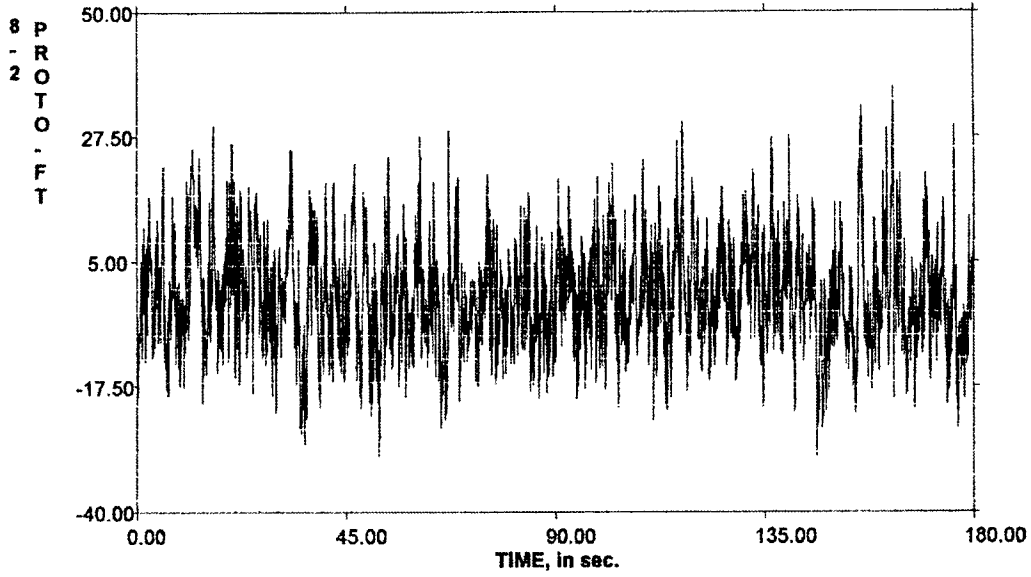

C:\WESDAQ1\BLUSTONE\C4-1, Channel Number 2

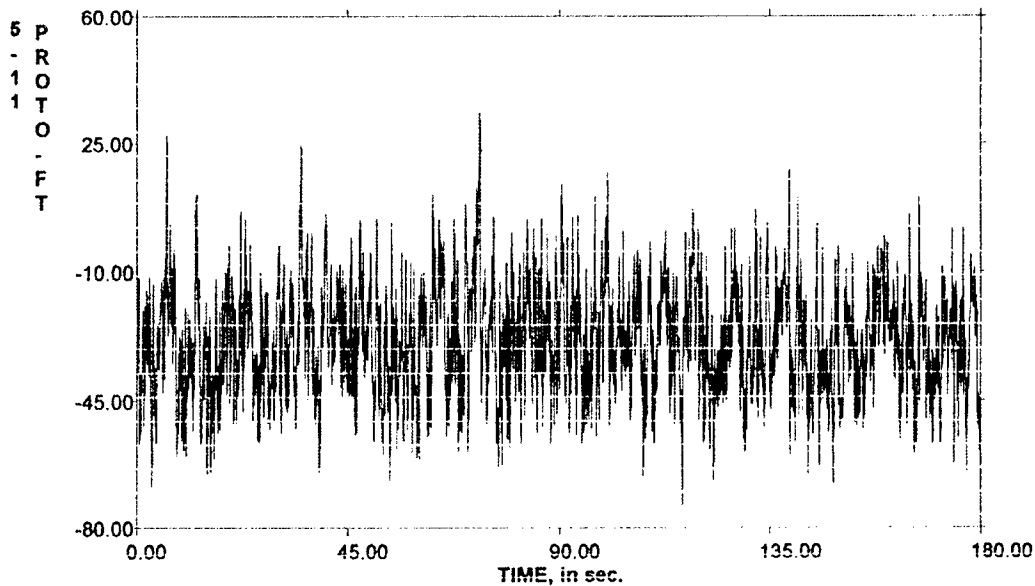

C:\WESDAQ1\BLUSTONE\C4-1, Channel Number 5

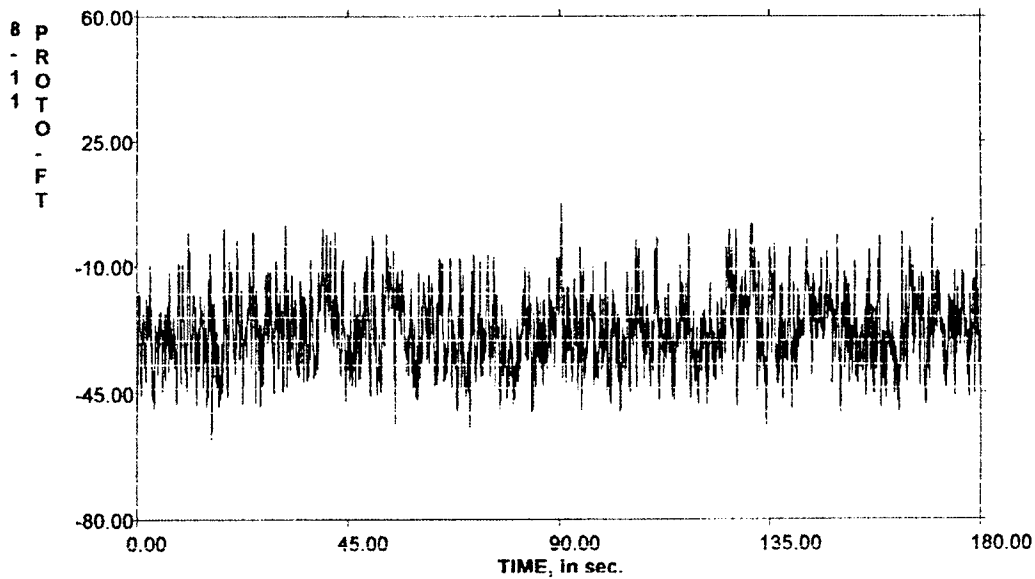

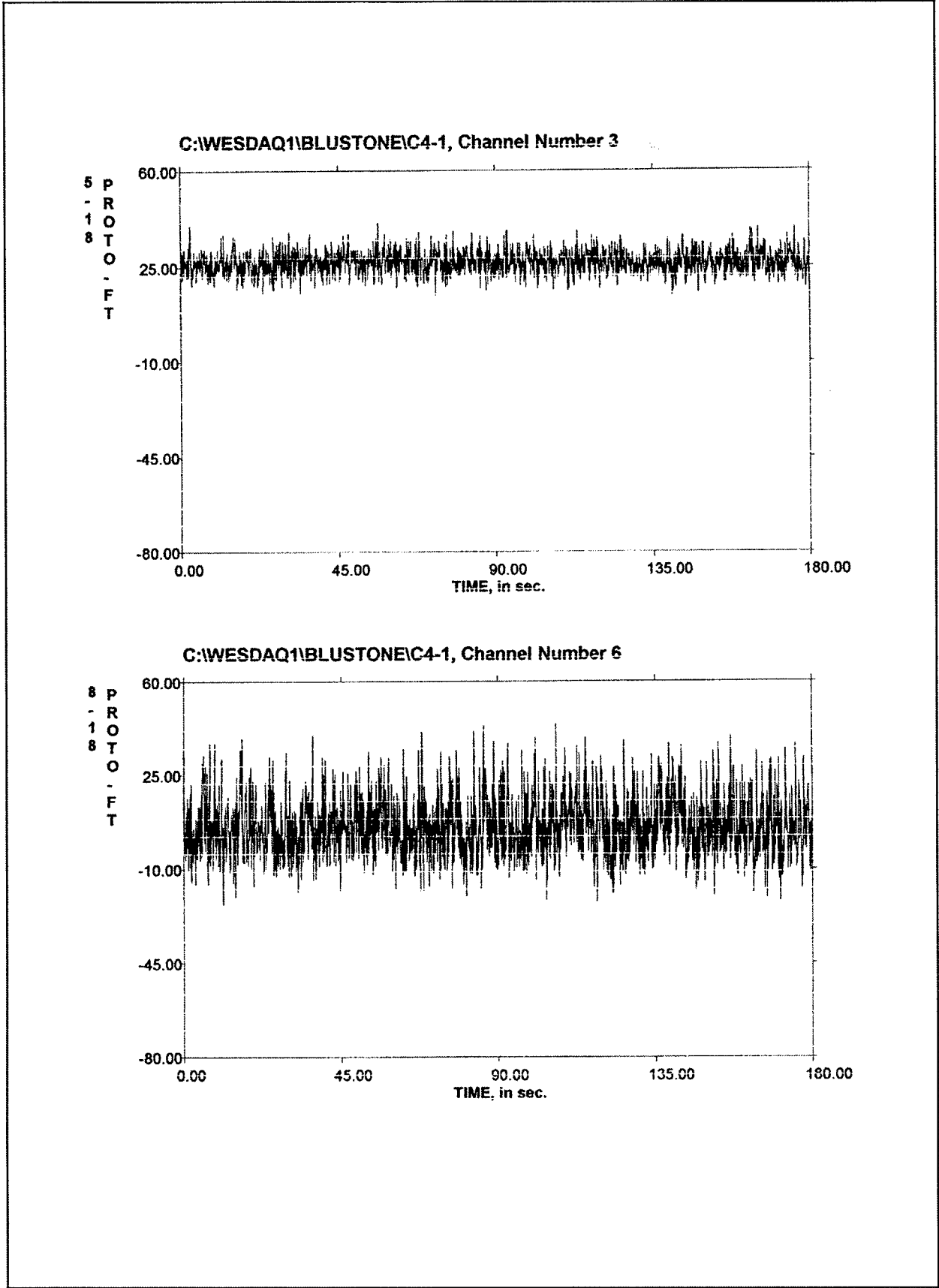

Information File Name: c:\wesdaq1\C4-2.inf
 Sample Rate: 50.000 samples/sec/channel
 Number of Seconds Recorded: 180.000 seconds
 Data Collected on 6/2/00 2:25:18 PM
 Bluestone Dam Model
 1:65 Scale
 Condition No. 4: Pool Elevation = 1504.7 Ft. Prototype
 All 6 channels filtered at 10 Hz. Low Pass
 All Calibrations and Data Recorded are in Prototype feet
 All channels are balanced and calibrated at 23.0 Ft. Prototype,
 Model Water Level at top of Stilling Weir.

ISDD Operator: Wallace Guy

STATISTICS						
CHAN	MINIMUM	AVERAGE	MAXIMUM	STANDARD	ROOT MEAN	ENGINEERING UNI
NUM	MEASUREMENT	MEASUREMENT	MEASUREMENT	DEVIATION	SQUARE	
1	14.489	27.748	43.915	3.926	28.024	PROTO-FT
2	-74.871	-28.769	22.264	14.199	32.082	PROTO-FT
3	11.171	26.294	43.785	3.729	26.557	PROTO-FT
4	-24.807	-1.131	33.497	8.470	8.546	PROTO-FT
5	-55.905	-27.328	11.660	10.137	29.148	PROTO-FT
6	-34.883	5.951	46.348	9.814	11.478	PROTO-FT

CALIBRATION INFORMATION							
CHAN	GAIN	BASE	CALSTEP	BASE	CAL STEP	ENGINEERING UNITS	TYPE OF G
NUM		VOLTAGE	VOLTAGE	ENG VALUE	ENG VALUE		
1	1.0	-0.005	2.010	23.000	51.199	PROTO-FT	5-2
2	1.0	0.008	1.044	23.000	50.701	PROTO-FT	5-11
3	1.0	0.011	2.009	23.000	48.036	PROTO-FT	5-18
4	1.0	0.013	1.463	23.000	44.900	PROTO-FT	8-2
5	1.0	0.003	1.067	23.000	51.205	PROTO-FT	8-11
6	1.0	-0.010	1.835	23.000	58.566	PROTO-FT	8-18

C:\WESDAQ1\BLUSTONE\C4-2, Channel Number 1

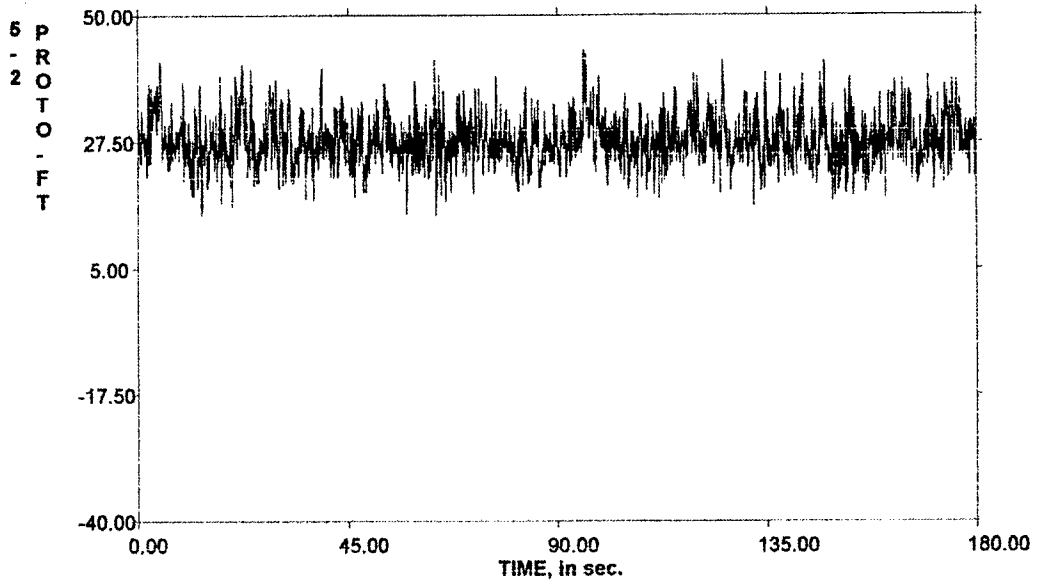

C:\WESDAQ1\BLUSTONE\C4-2, Channel Number 6

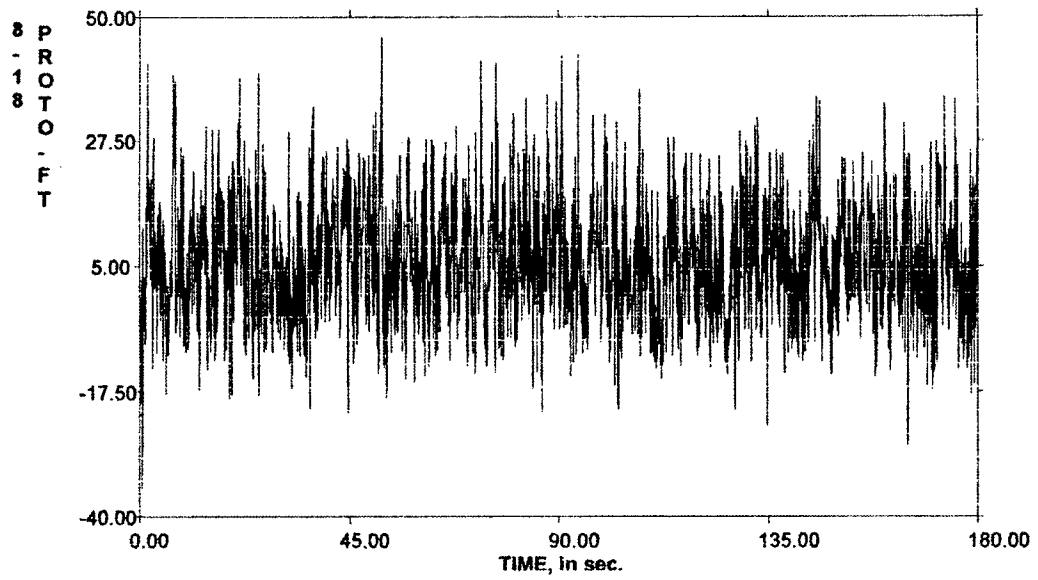

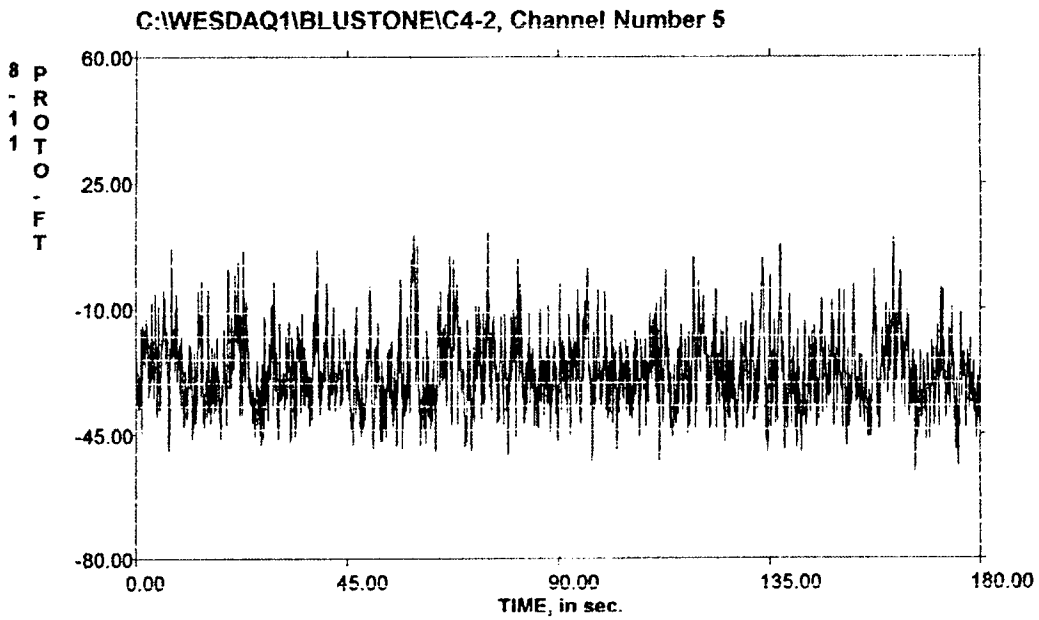
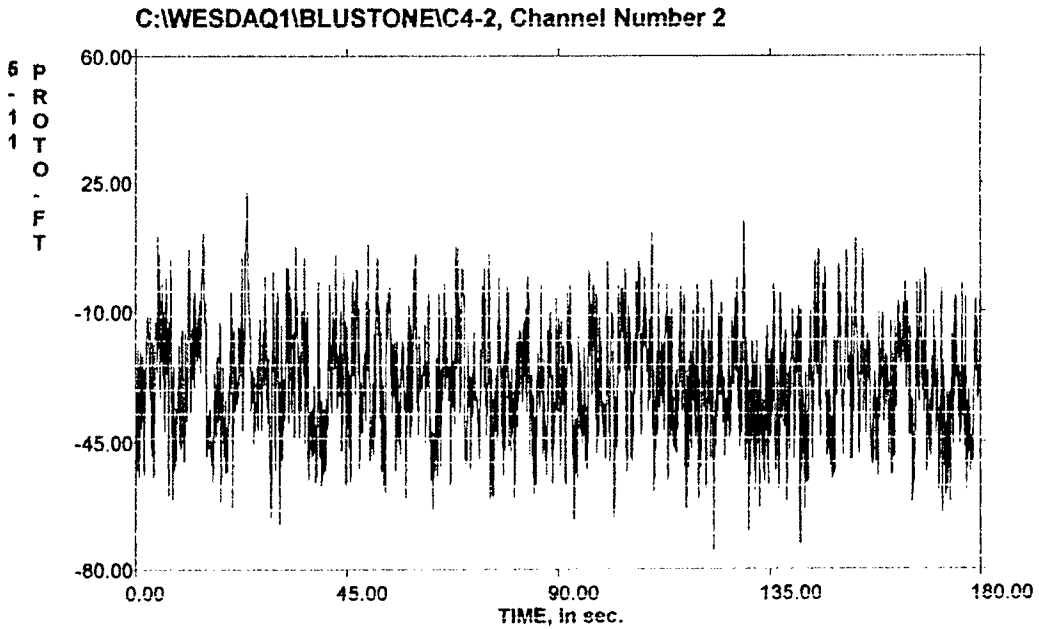

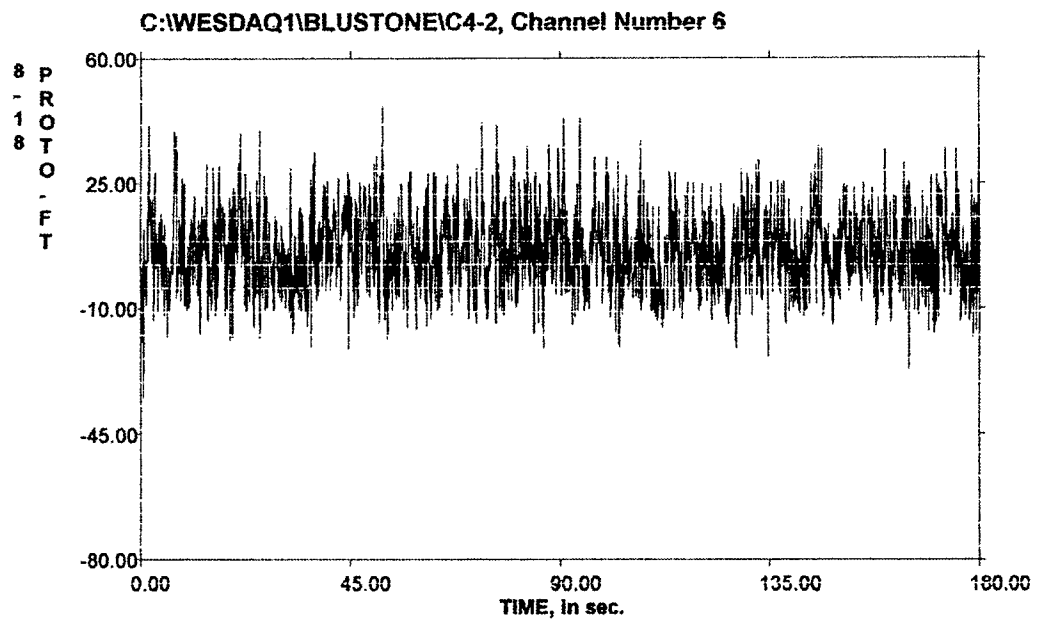
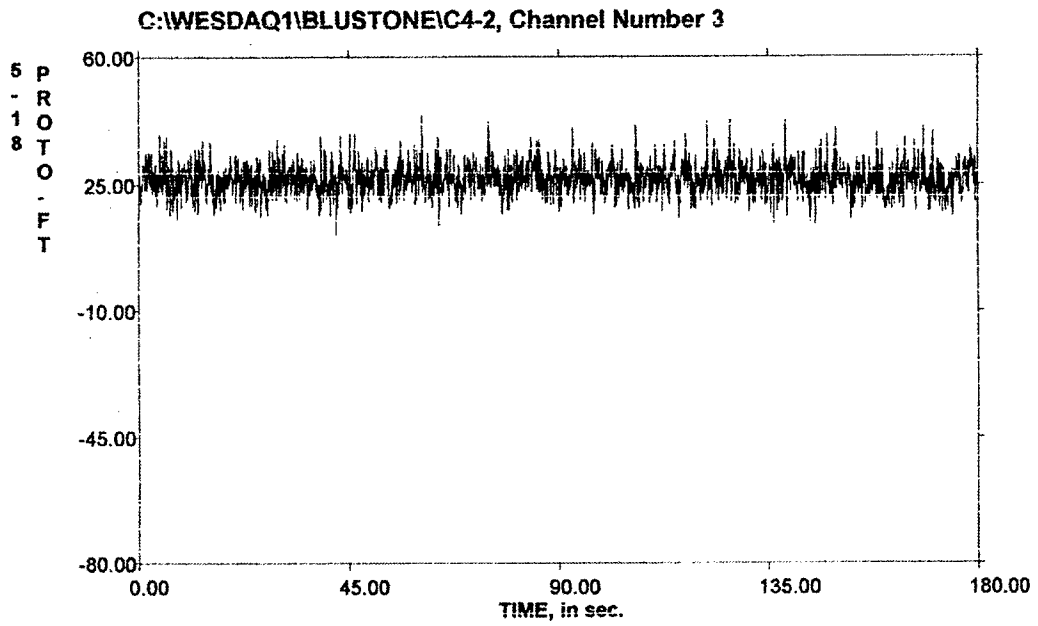

Information File Name: c:\wesdaq1\C4-3.inf
 Sample Rate: 50.000 samples/sec/channel
 Number of Seconds Recorded: 180.000 seconds
 Data Collected on 6/2/00 2:31:15 PM
 Bluestone Dam Model
 1:65 Scale
 Condition No. 4: Pool Elevation = 1504.7 Ft. Prototype
 All 6 channels filtered at 10 Hz. Low Pass
 All Calibrations and Data Recorded are in Prototype feet
 All channels are balanced and calibrated at 23.0 Ft. Prototype,
 Model Water Level at top of Stilling Weir.

ISDD Operator: Wallace Guy

STATISTICS						
CHAN	MINIMUM	AVERAGE	MAXIMUM	STANDARD	ROOT MEAN	ENGINEERING UNI
NUM	MEASUREMENT	MEASUREMENT	MEASUREMENT	DEVIATION	SQUARE	
1	13.498	28.334	48.119	4.191	28.642	PROTO-FT
2	-73.239	-28.783	19.522	13.953	31.987	PROTO-FT
3	10.100	26.238	41.582	3.598	26.483	PROTO-FT
4	-25.250	-1.876	32.723	8.649	8.850	PROTO-FT
5	-59.464	-27.350	15.025	10.054	29.139	PROTO-FT
6	-24.058	6.357	51.948	10.093	11.928	PROTO-FT

CALIBRATION INFORMATION							
CHAN	GAIN	BASE	CALSTEP	BASE	CAL STEP	ENGINEERING UNITS	TYPE OF G
NUM		VOLTAGE	VOLTAGE	ENG VALUE	ENG VALUE		
1	1.0	-0.005	2.010	23.000	51.199	PROTO-FT	5-2
2	1.0	0.008	1.044	23.000	50.701	PROTO-FT	5-11
3	1.0	0.011	2.009	23.000	48.036	PROTO-FT	5-18
4	1.0	0.013	1.463	23.000	44.900	PROTO-FT	8-2
5	1.0	0.003	1.067	23.000	51.205	PROTO-FT	8-11
6	1.0	-0.010	1.835	23.000	58.566	PROTO-FT	8-18

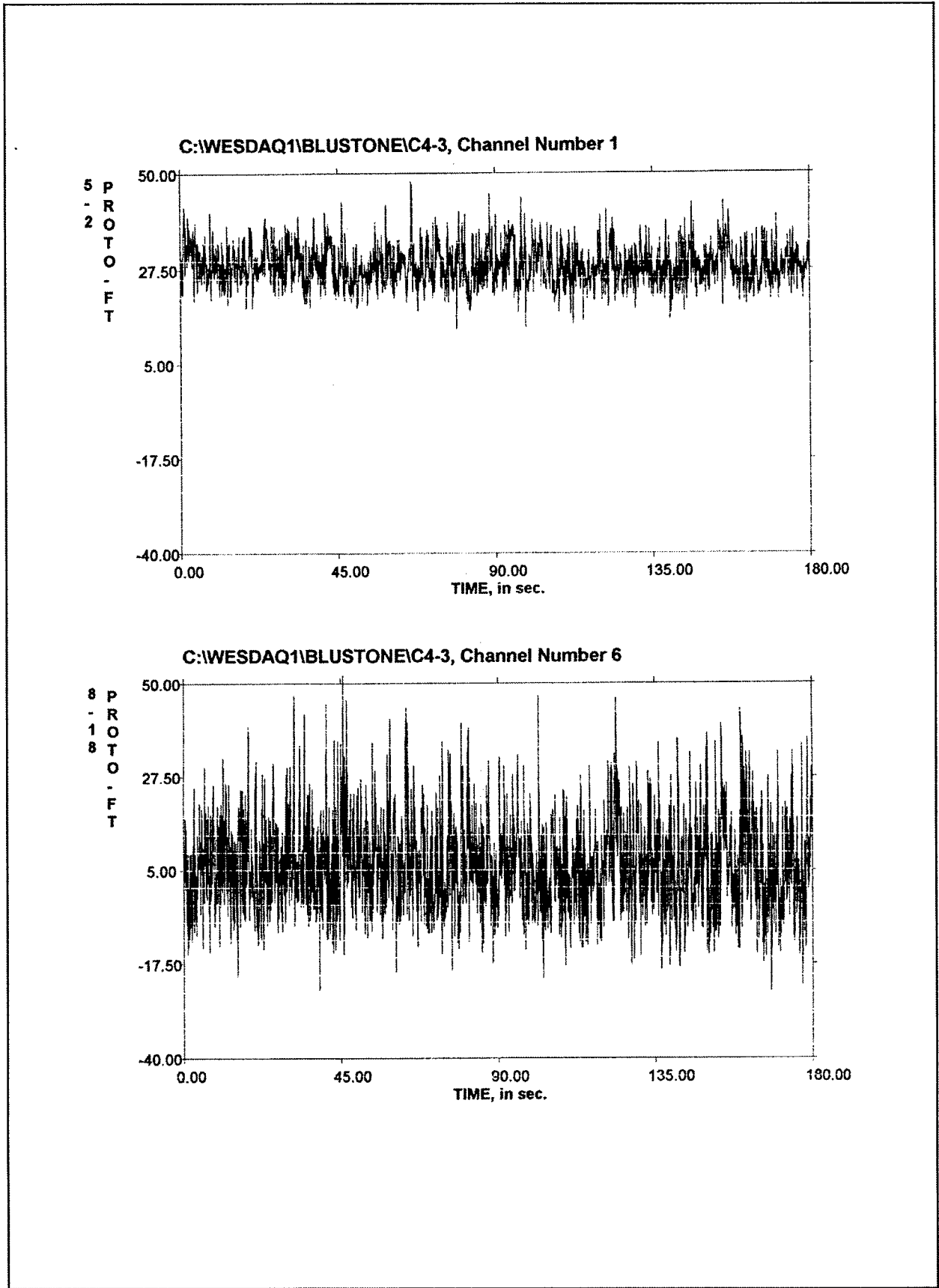

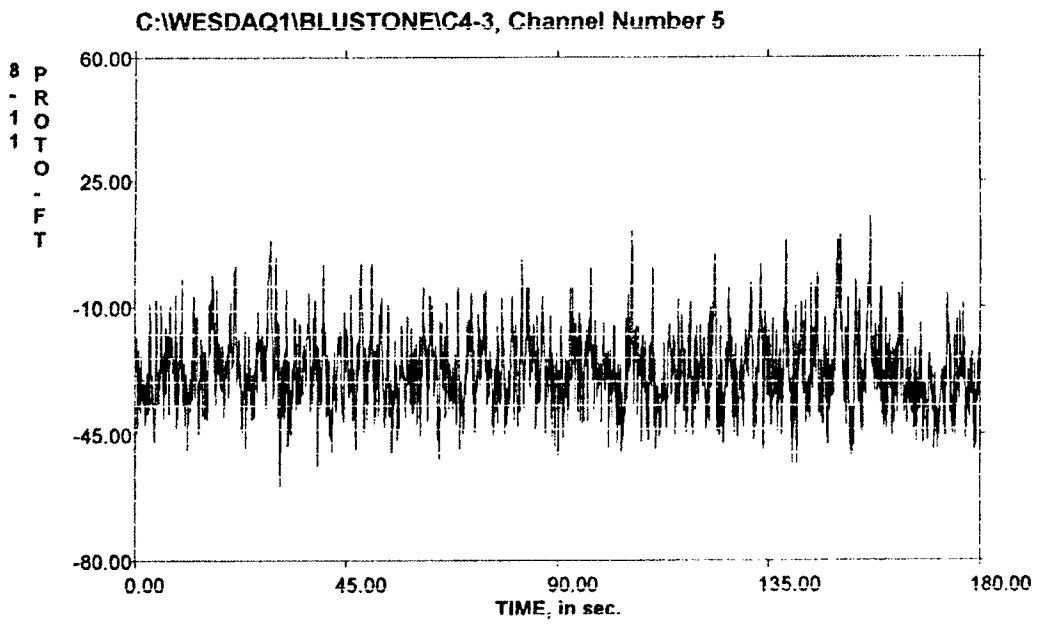
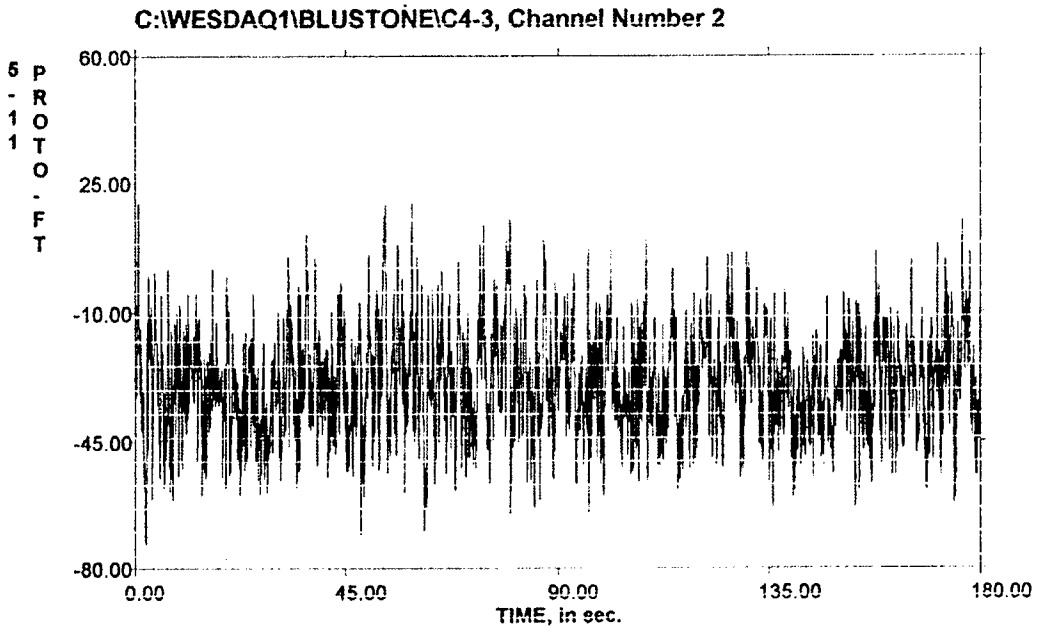

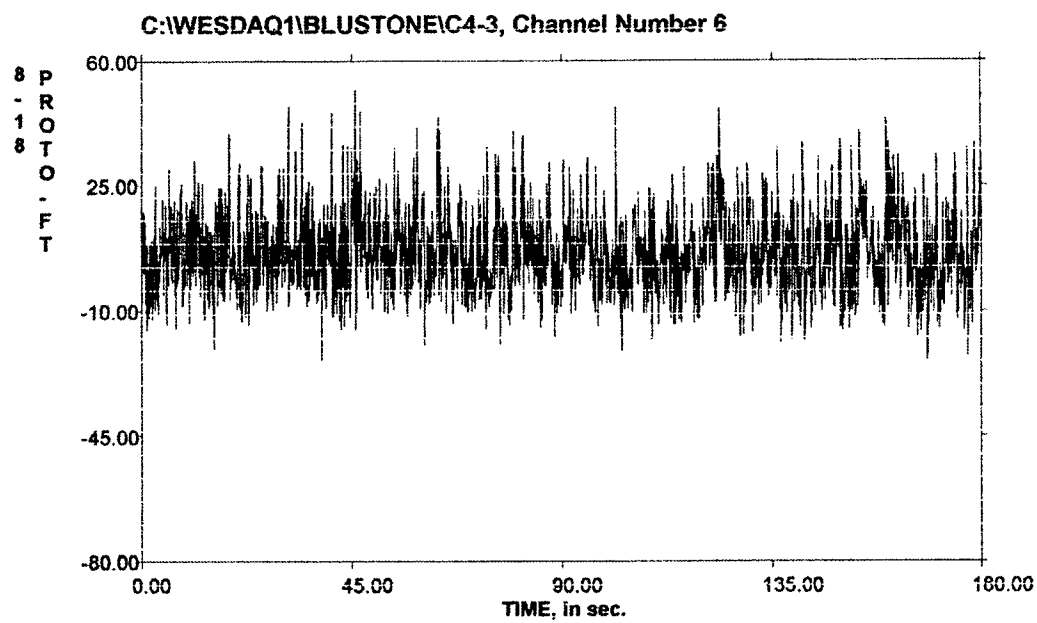
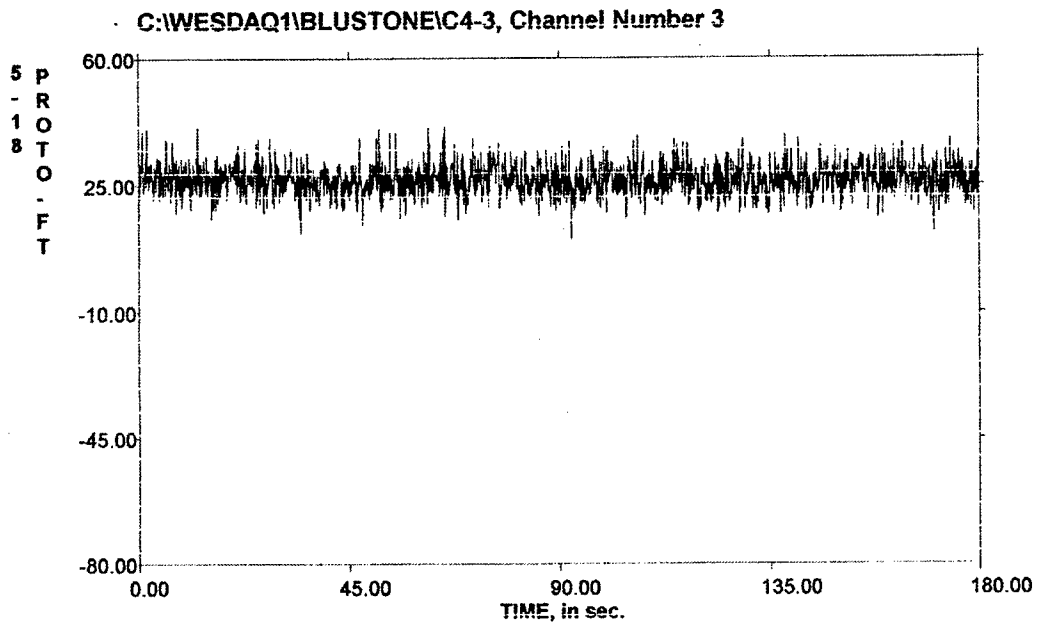

Information File Name: c:\wesdaq1\C5-1.inf
 Sample Rate: 50.000 samples/sec/channel
 Number of Seconds Recorded: 180.000 seconds
 Data Collected on 6/2/00 1:51:08 PM
 Bluestone Dam Model
 1:65 Scale
 Condition No. 5: Pool Elevation = 1515.1 Ft. Prototype
 All 6 channels filtered at 10 Hz. Low Pass
 All Calibrations and Data Recorded are in Prototype feet
 All channels are balanced and calibrated at 23.0 Ft. Prototype,
 Model Water Level at top of Stilling Weir.

ISDD Operator: Wallace Guy

STATISTICS						
CHAN	MINIMUM	AVERAGE	MAXIMUM	STANDARD	ROOT MEAN	ENGINEERING UNI
NUM	MEASUREMENT	MEASUREMENT	MEASUREMENT	DEVIATION	SQUARE	
1	19.957	33.250	57.005	4.427	33.544	PROTO-FT
2	-80.028	-40.222	10.710	13.396	42.394	PROTO-FT
3	13.619	27.895	48.068	4.102	28.195	PROTO-FT
4	-25.582	1.000	37.185	9.001	9.056	PROTO-FT
5	-56.423	-29.318	16.772	10.309	31.078	PROTO-FT
6	-36.765	8.000	50.207	9.721	12.589	PROTO-FT

CALIBRATION INFORMATION							
CHAN	GAIN	BASE	CALSTEP	BASE	CAL STEP	ENGINEERING UNITS	TYPE OF G
NUM		VOLTAGE	VOLTAGE	ENG VALUE	ENG VALUE		
1	1.0	-0.005	2.010	23.000	51.199	PROTO-FT	5-2
2	1.0	0.008	1.044	23.000	50.701	PROTO-FT	5-11
3	1.0	0.011	2.009	23.000	48.036	PROTO-FT	5-18
4	1.0	0.013	1.463	23.000	44.900	PROTO-FT	8-2
5	1.0	0.003	1.067	23.000	51.205	PROTO-FT	8-11
6	1.0	-0.010	1.835	23.000	58.566	PROTO-FT	8-18

C:\WESDAQ1\BLUSTONE\C5-1, Channel Number 1

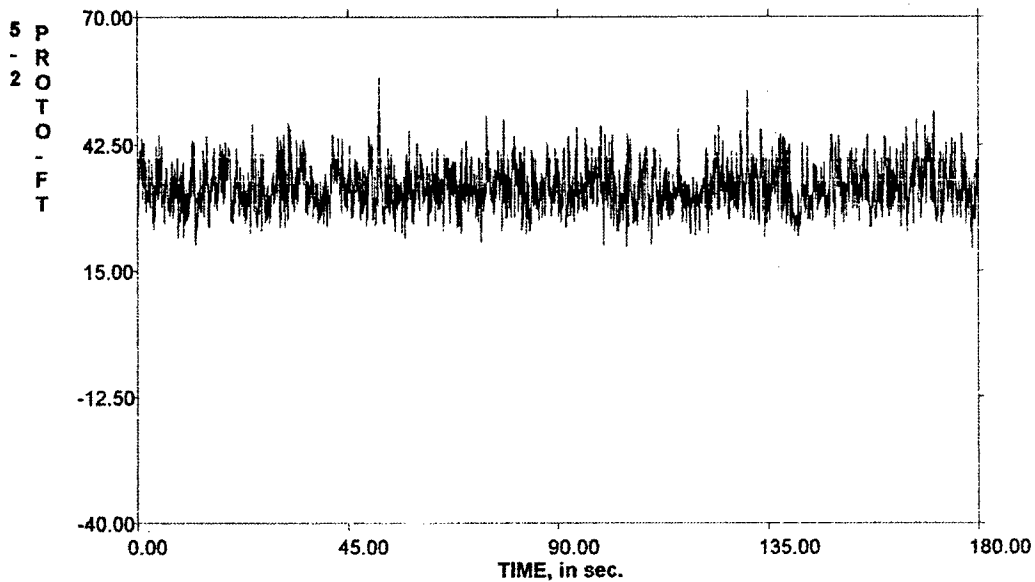

C:\WESDAQ1\BLUSTONE\C5-1, Channel Number 4

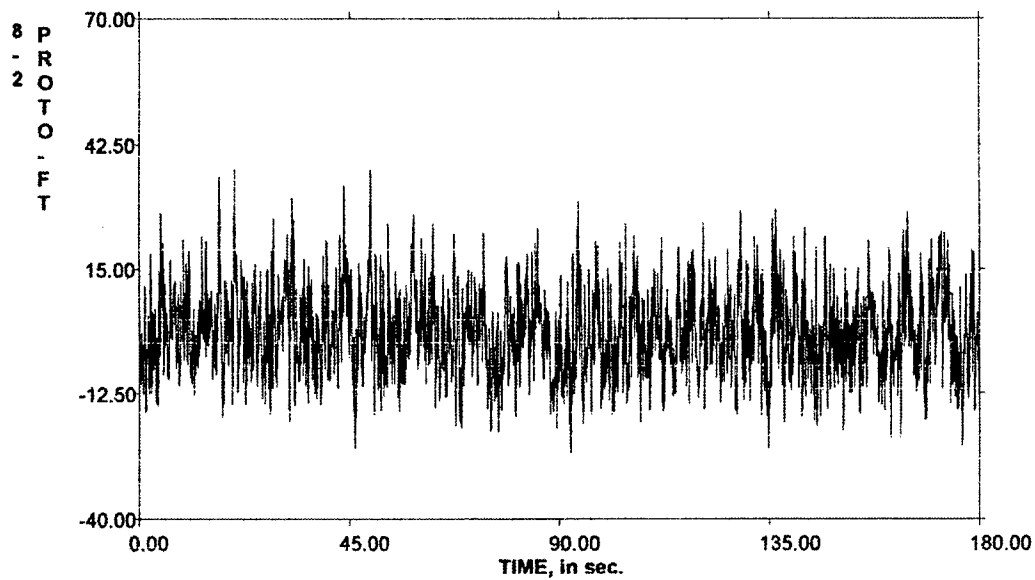

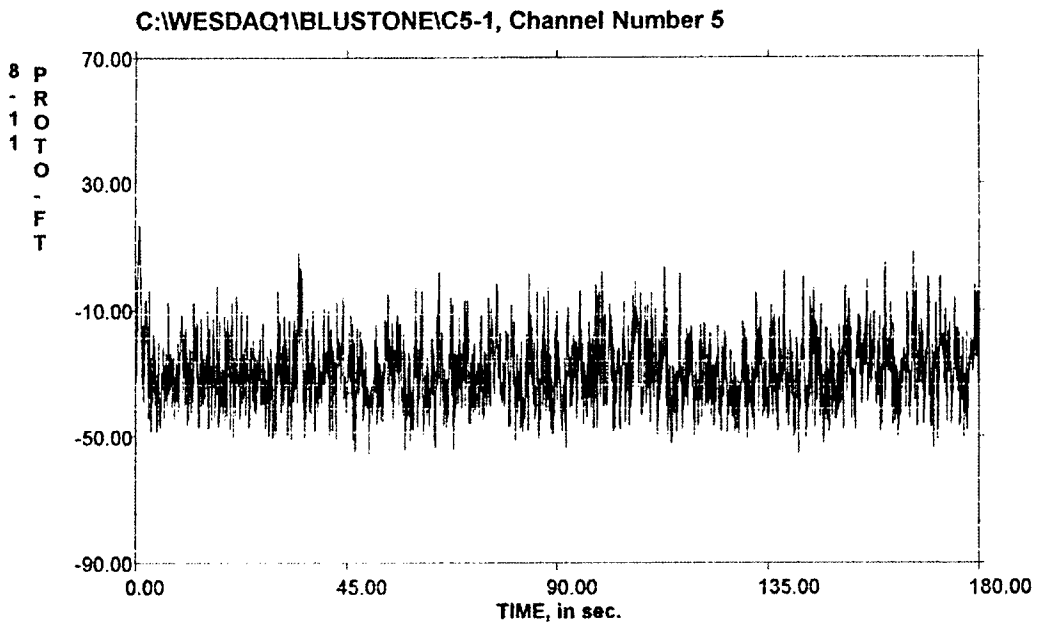
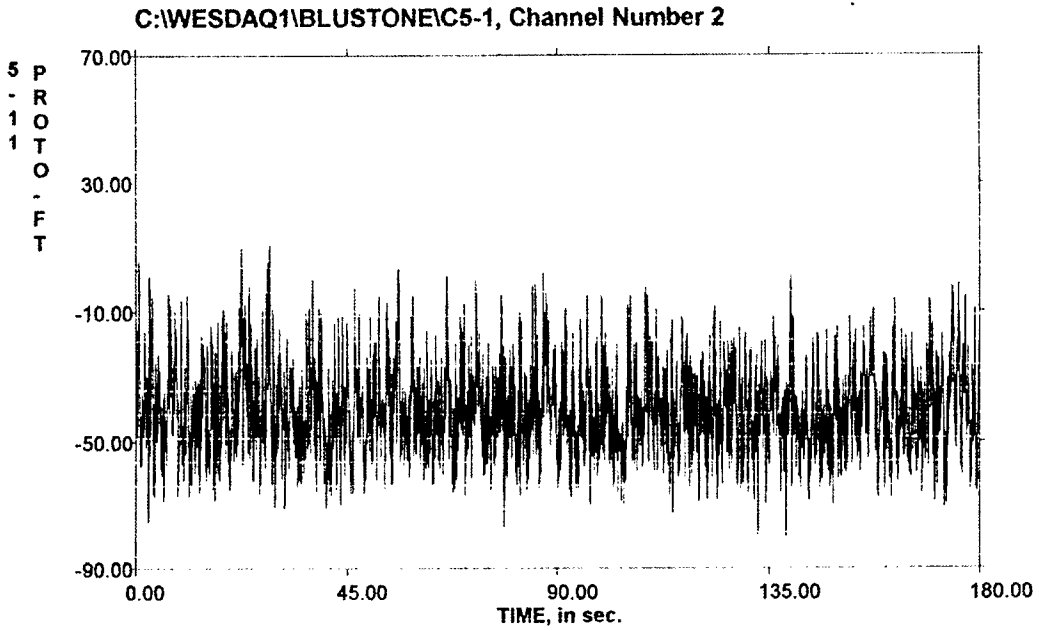

C:\WESDAQ1\BLUSTONE\C5-1, Channel Number 3

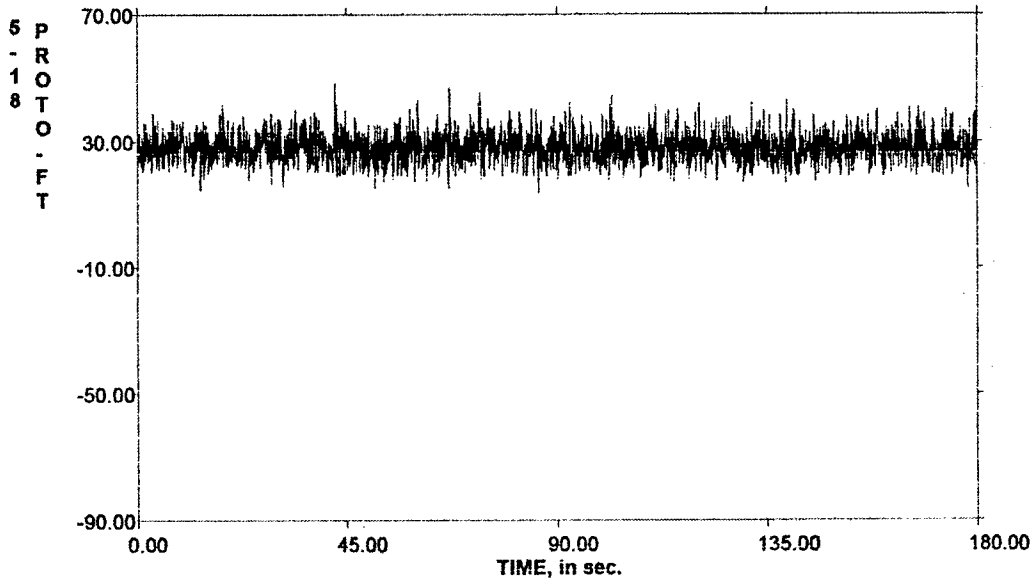

C:\WESDAQ1\BLUSTONE\C5-1, Channel Number 6

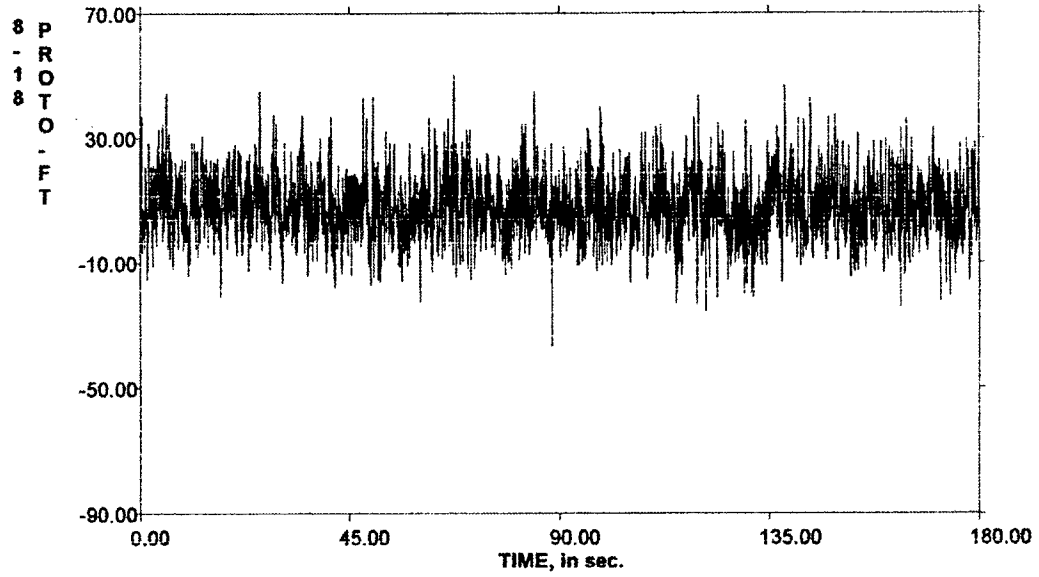

Information File Name: c:\wesdaq1\C5-2.inf
 Sample Rate: 50.000 samples/sec/channel
 Number of Seconds Recorded: 180.000 seconds
 Data Collected on 6/2/00 1:58:48 PM
 Bluestone Dam Model
 1:65 Scale
 Condition No. 5: Pool Elevation = 1515.1 Ft. Prototype
 All 6 channels filtered at 10 Hz. Low Pass
 All Calibrations and Data Recorded are in Prototype feet
 All channels are balanced and calibrated at 23.0 Ft. Prototype,
 Model Water Level at top of Stilling Weir.

ISDD Operator: Wallace Guy

STATISTICS						
CHAN	MINIMUM	AVERAGE	MAXIMUM	STANDARD	ROOT MEAN	ENGINEERING UNI
NUM	MEASUREMENT	MEASUREMENT	MEASUREMENT	DEVIATION	SQUARE	
1	20.504	32.826	51.400	4.472	33.130	PROTO-FT
2	-77.613	-40.386	15.867	13.351	42.535	PROTO-FT
3	13.405	27.995	45.162	4.314	28.325	PROTO-FT
4	-36.571	1.267	36.484	9.374	9.459	PROTO-FT
5	-57.523	-28.801	4.217	10.186	30.549	PROTO-FT
6	-24.341	7.324	49.266	9.616	12.087	PROTO-FT

CALIBRATION INFORMATION							
CHAN	GAIN	BASE	CALSTEP	BASE	CAL	STEP	ENGINEERING UNITS
NUM		VOLTAGE	VOLTAGE	ENG VALUE	ENG VALUE		
1	1.0	-0.005	2.010	23.000	51.199		PROTO-FT
2	1.0	0.008	1.044	23.000	50.701		PROTO-FT
3	1.0	0.011	2.009	23.000	48.036		PROTO-FT
4	1.0	0.013	1.463	23.000	44.900		PROTO-FT
5	1.0	0.003	1.067	23.000	51.205		PROTO-FT
6	1.0	-0.010	1.835	23.000	58.566		PROTO-FT

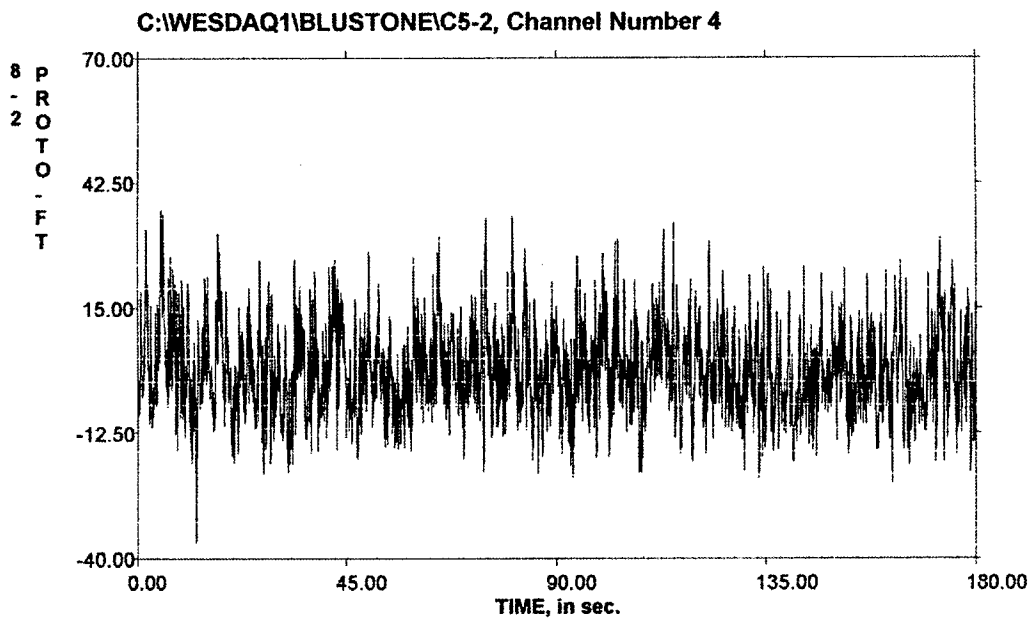
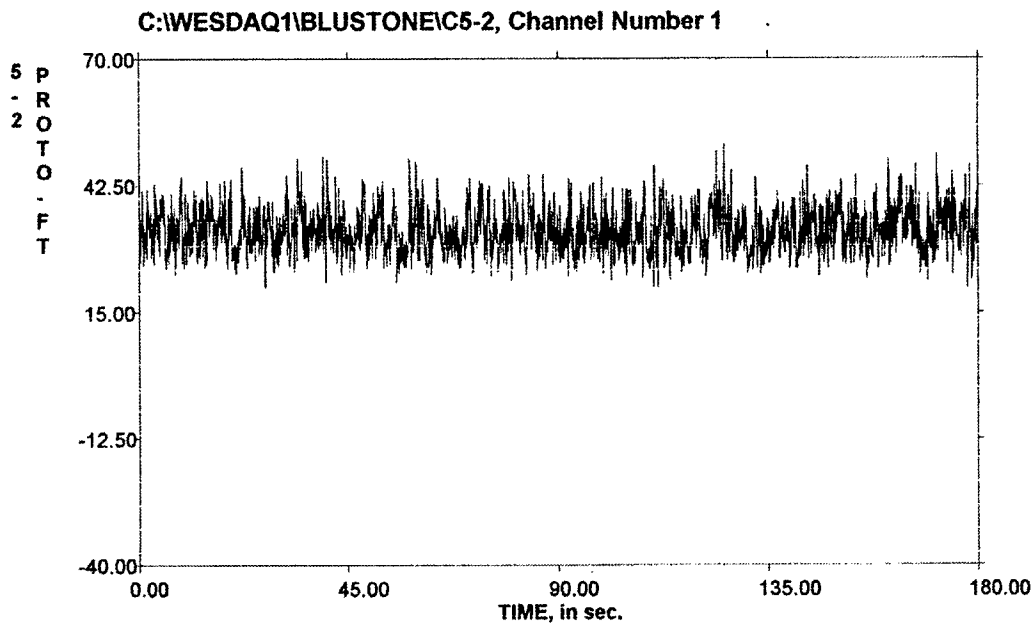

C:\WESDAQ1\BLUSTONE\C5-2, Channel Number 2

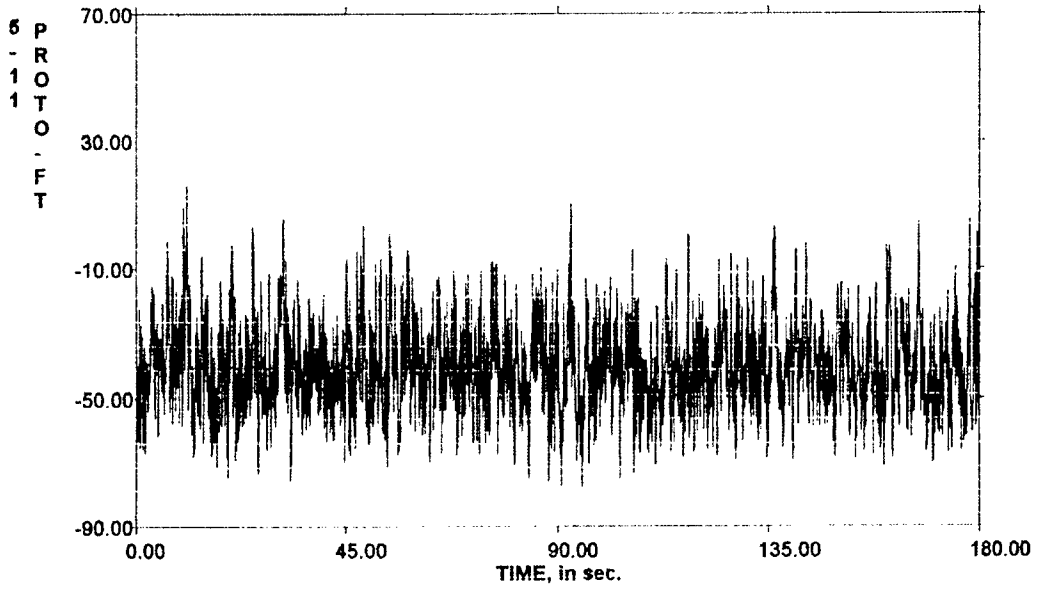

C:\WESDAQ1\BLUSTONE\C5-2, Channel Number 5

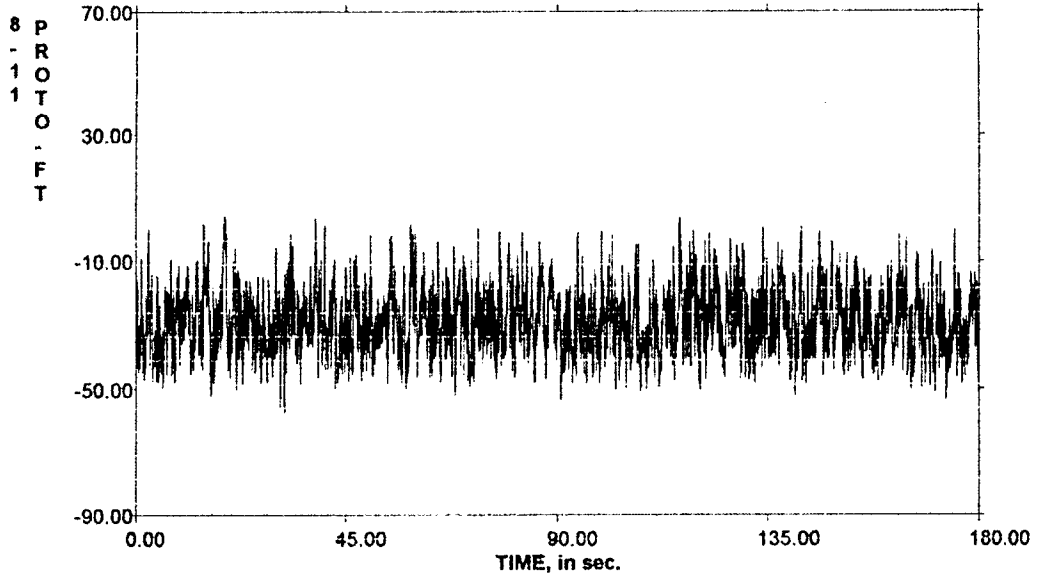

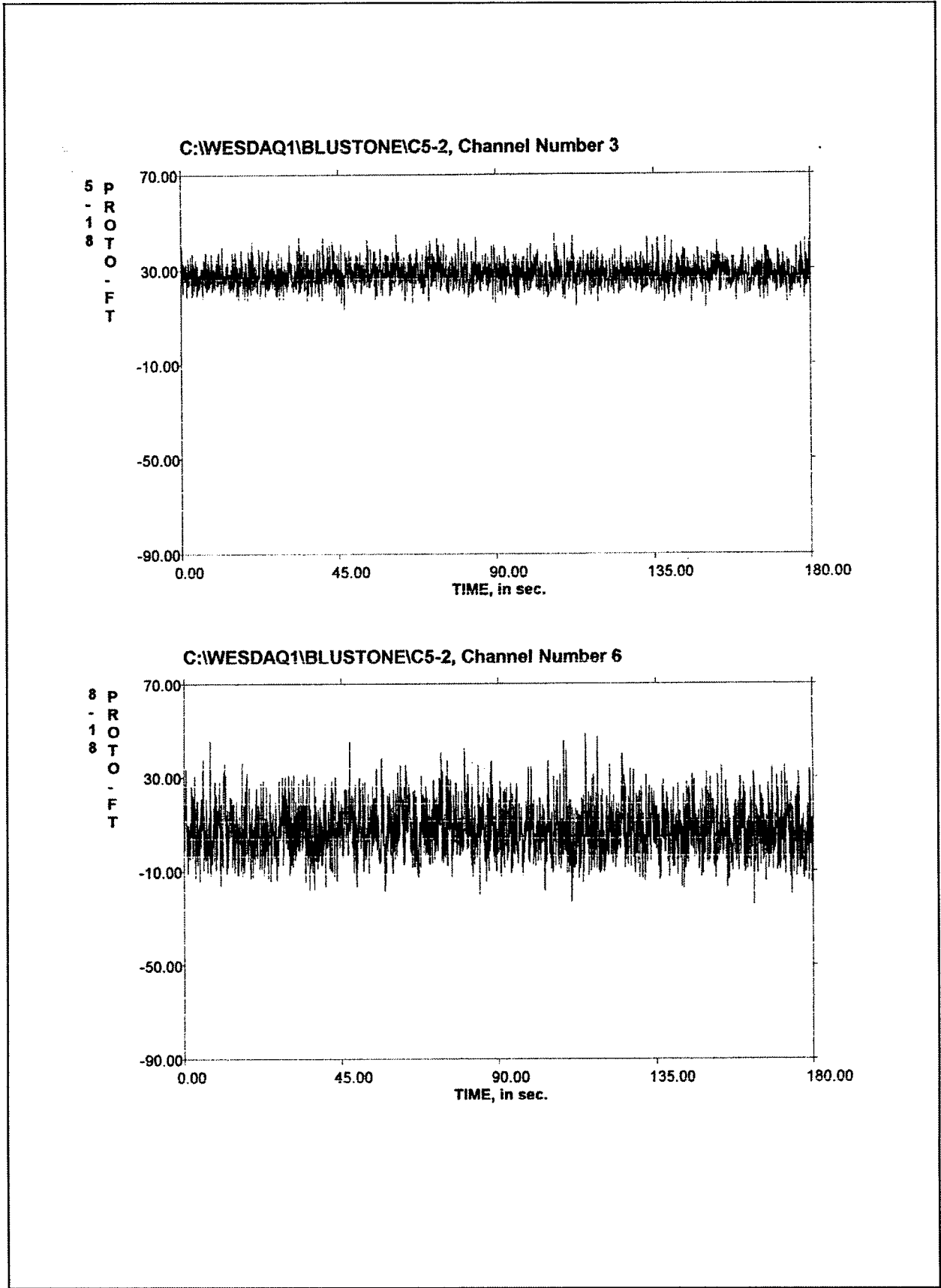

Information File Name: c:\wesdaq1\C5-3.inf
 Sample Rate: 50.000 samples/sec/channel
 Number of Seconds Recorded: 180.000 seconds
 Data Collected on 6/2/00 2:05:42 PM
 Bluestone Dam Model
 1:65 Scale
 Condition No. 5: Pool Elevation = 1515.1 Ft. Prototype
 All 6 channels filtered at 10 Hz. Low Pass
 All Calibrations and Data Recorded are in Prototype feet
 All channels are balanced and calibrated at 23.0 Ft. Prototype,
 Model Water Level at top of Stilling Weir.

ISDD Operator: Wallace Guy

STATISTICS						
CHAN	MINIMUM	AVERAGE	MAXIMUM	STANDARD	ROOT MEAN	ENGINEERING UNI
NUM	MEASUREMENT	MEASUREMENT	MEASUREMENT	DEVIATION	SQUARE	
1	17.804	32.932	59.944	4.520	33.241	PROTO-FT
2	-77.678	-40.005	12.341	13.323	42.165	PROTO-FT
3	12.976	27.773	47.701	4.303	28.105	PROTO-FT
4	-31.187	0.586	34.530	8.657	8.677	PROTO-FT
5	-60.759	-28.273	16.255	10.534	30.172	PROTO-FT
6	-23.588	7.617	54.960	9.900	12.491	PROTO-FT

CALIBRATION INFORMATION						
CHAN	GAIN	BASE CALSTEP	BASE	CAL STEP	ENGINEERING UNITS	TYPE OF G
NUM		VOLTAGE	VOLTAGE	ENG VALUE	ENG VALUE	
1	1.0	-0.005	2.010	23.000	51.199	PROTO-FT 5-2
2	1.0	0.008	1.044	23.000	50.701	PROTO-FT 5-11
3	1.0	0.011	2.009	23.000	48.036	PROTO-FT 5-18
4	1.0	0.013	1.463	23.000	44.900	PROTO-FT 8-2
5	1.0	0.003	1.067	23.000	51.205	PROTO-FT 8-11
6	1.0	-0.010	1.835	23.000	58.566	PROTO-FT 8-18

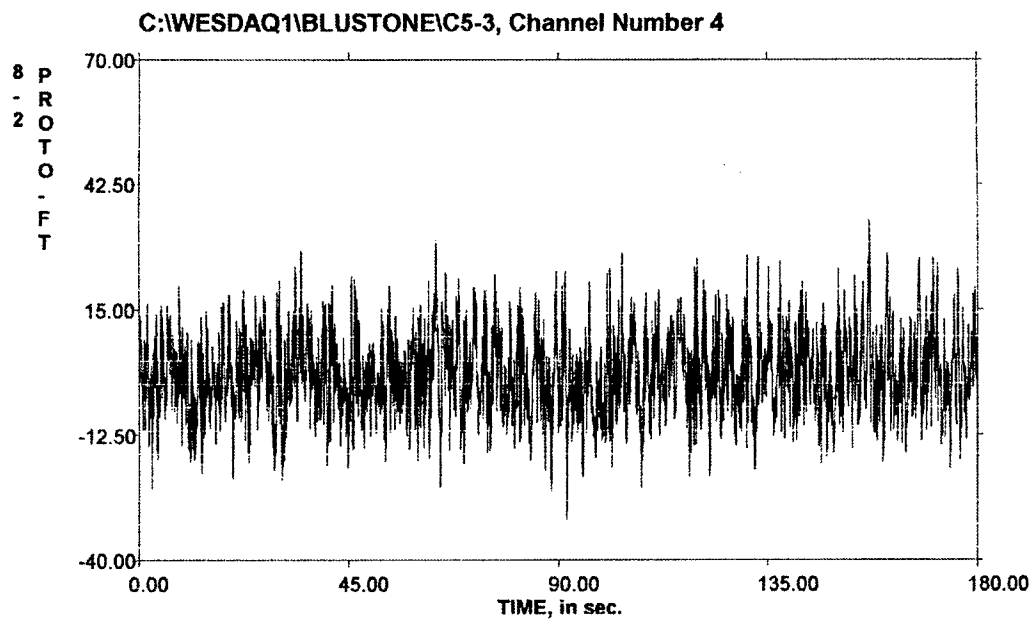
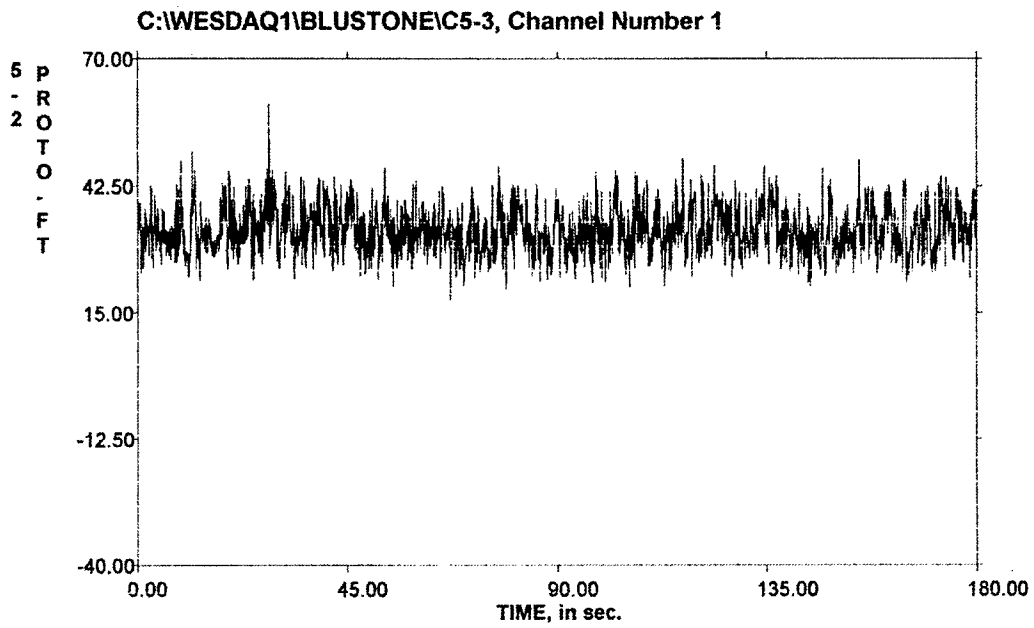

C:\WESDAQ1\BLUSTONE\C5-3, Channel Number 2

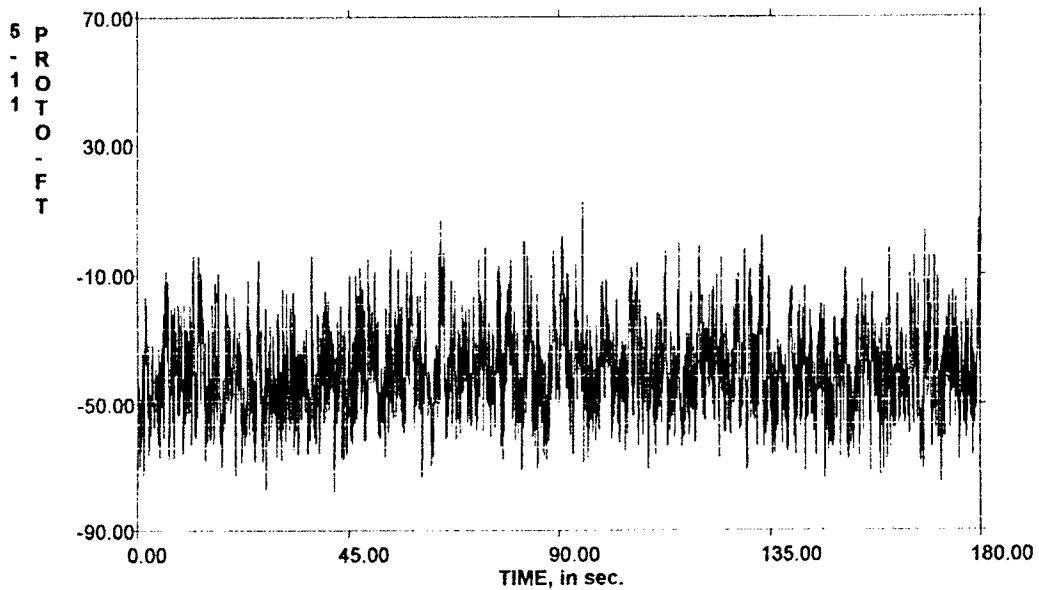

C:\WESDAQ1\BLUSTONE\C5-3, Channel Number 5

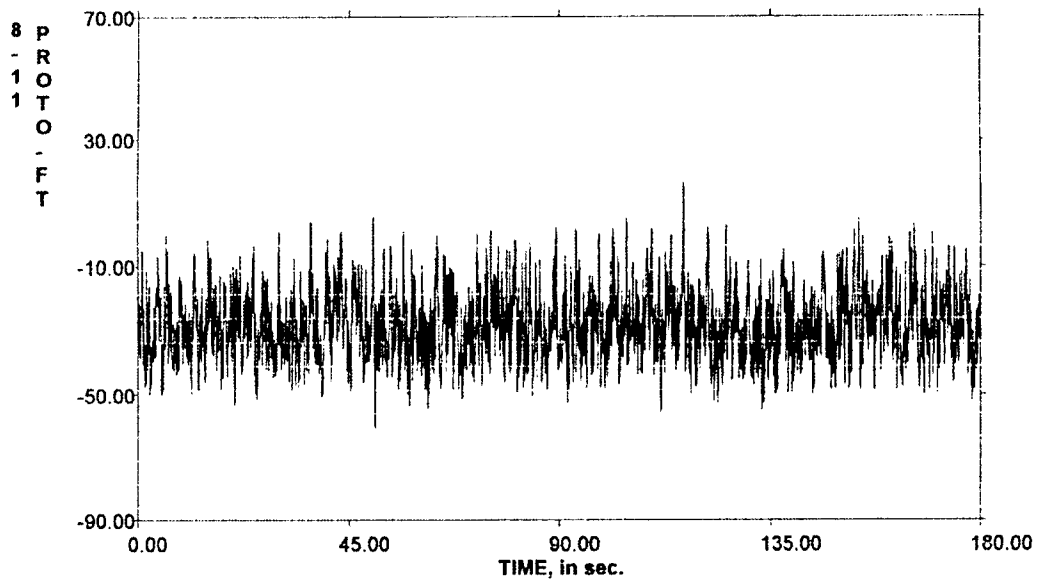

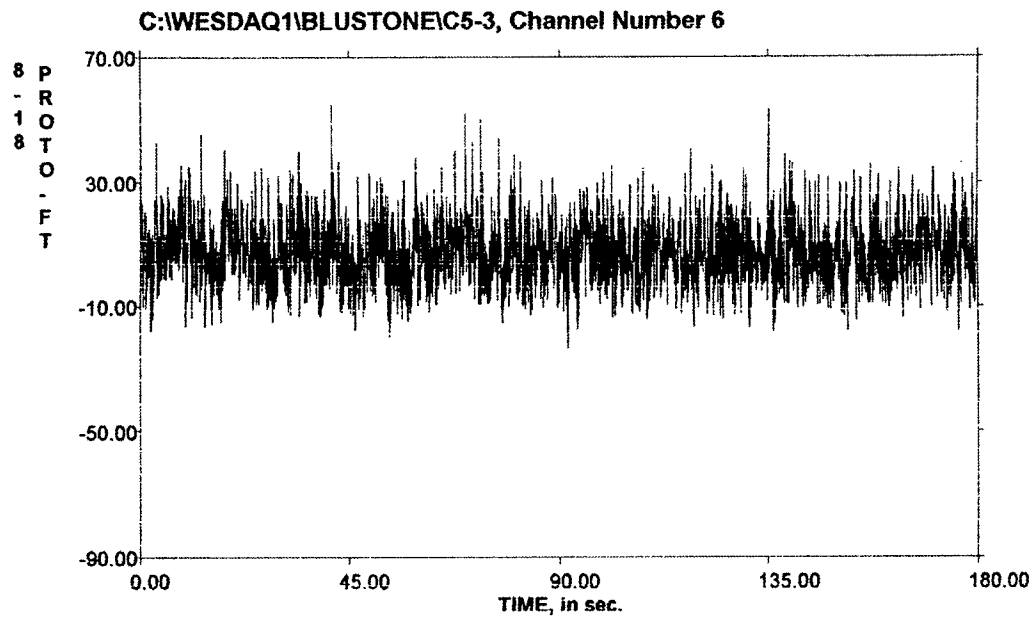
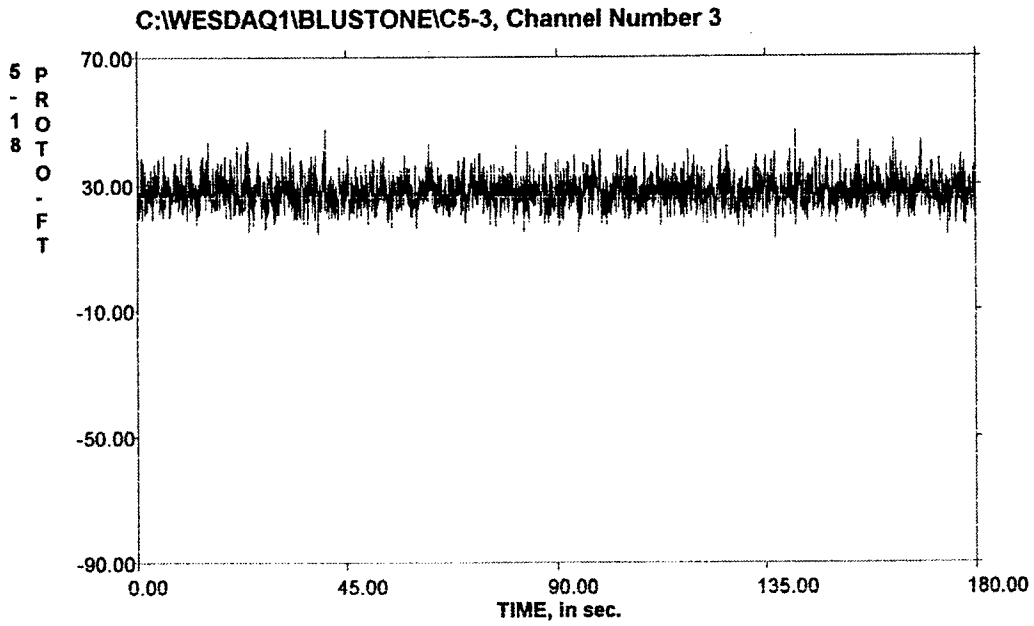

Information File Name: c:\wesdaq1\C6-1.inf
 Sample Rate: 50.000 samples/sec/channel
 Number of Seconds Recorded: 180.000 seconds
 Data Collected on 6/2/00 1:16:18 PM
 Bluestone Dam Model
 1:65 Scale
 Condition No. 6: Pool Elevation = 1520.2 Ft. Prototype
 All 6 channels filtered at 10 Hz. Low Pass
 All Calibrations and Data Recorded are in Prototype feet
 All channels are balanced and calibrated at 23.0 Ft. Prototype,
 Model Water Level at top of Stilling Weir.

ISDD Operator: Wallace Guy

STATISTICS						
CHAN	MINIMUM	AVERAGE	MAXIMUM	STANDARD	ROOT MEAN	ENGINEERING UNI
NUM	MEASUREMENT	MEASUREMENT	MEASUREMENT	DEVIATION	SQUARE	
1	16.130	35.835	56.150	4.175	36.077	PROTO-FT
2	-82.117	-53.281	11.297	12.015	54.618	PROTO-FT
3	12.823	27.728	47.548	4.297	28.059	PROTO-FT
4	-28.606	-2.069	29.108	8.214	8.471	PROTO-FT
5	-60.500	-37.149	10.301	9.270	38.288	PROTO-FT
6	-27.023	9.312	58.443	9.862	13.564	PROTO-FT

CALIBRATION INFORMATION						
CHAN	GAIN	BASE	CALSTEP	BASE	CAL STEP	ENGINEERING UNITS
NUM		VOLTAGE	VOLTAGE	ENG VALUE	ENG VALUE	
1	1.0	-0.005	2.010	23.000	51.199	PROTO-FT
2	1.0	0.008	1.044	23.000	50.701	PROTO-FT
3	1.0	0.011	2.009	23.000	48.036	PROTO-FT
4	1.0	0.013	1.463	23.000	44.900	PROTO-FT
5	1.0	0.003	1.067	23.000	51.205	PROTO-FT
6	1.0	-0.010	1.835	23.000	58.566	PROTO-FT

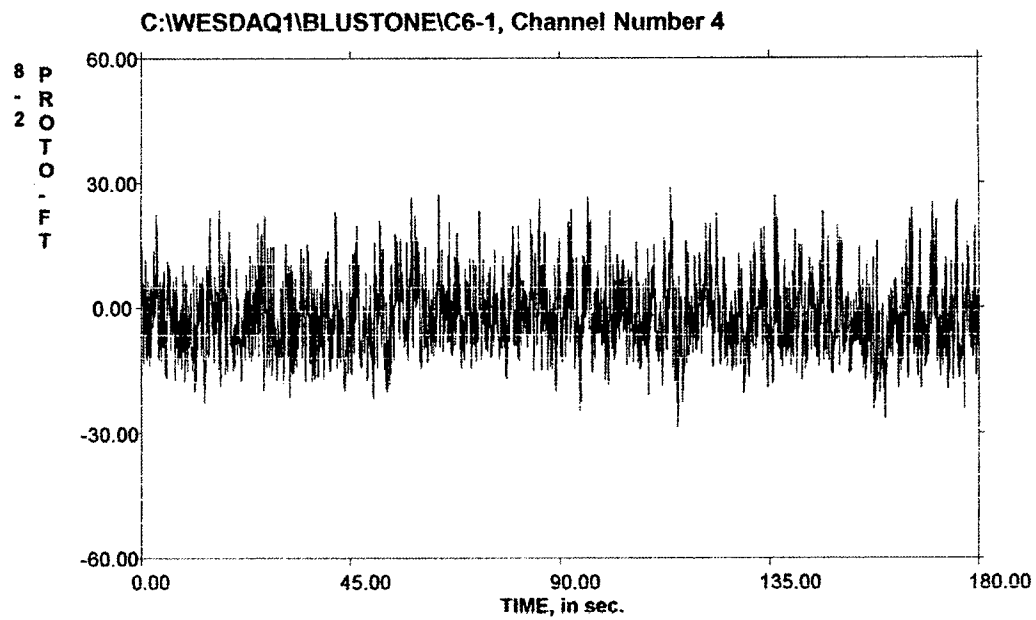
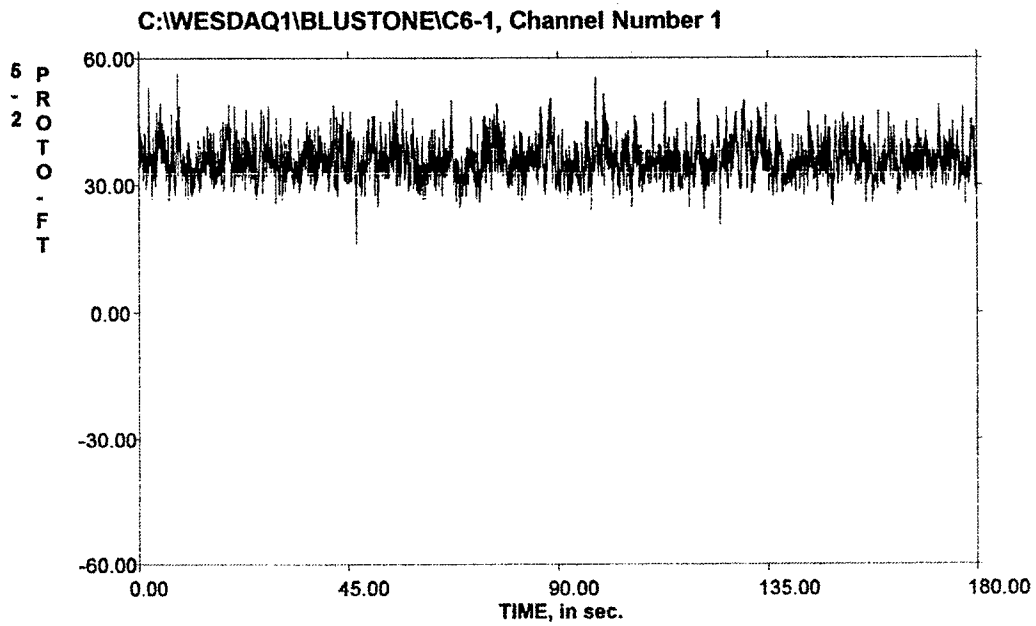

C:\WESDAQ1\BLUSTONE\C6-1, Channel Number 2

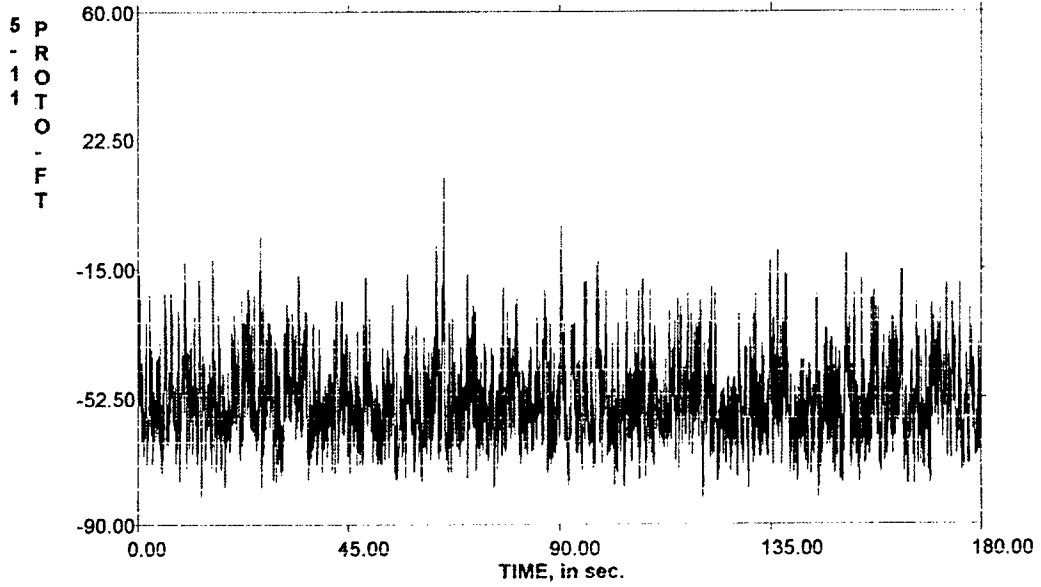

C:\WESDAQ1\BLUSTONE\C6-1, Channel Number 5

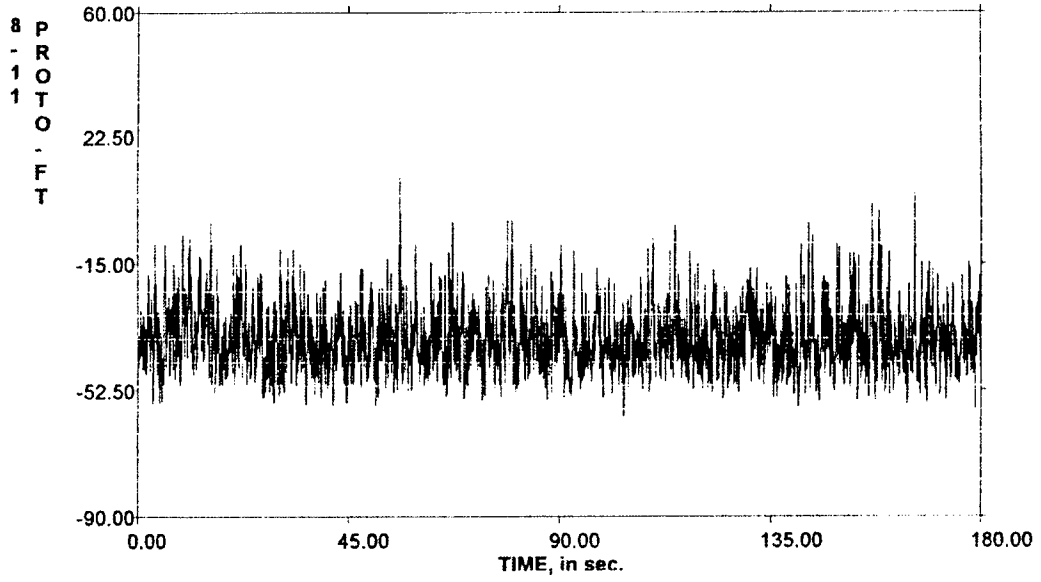

C:\WESDAQ1\BLUSTONE\C6-1, Channel Number 3

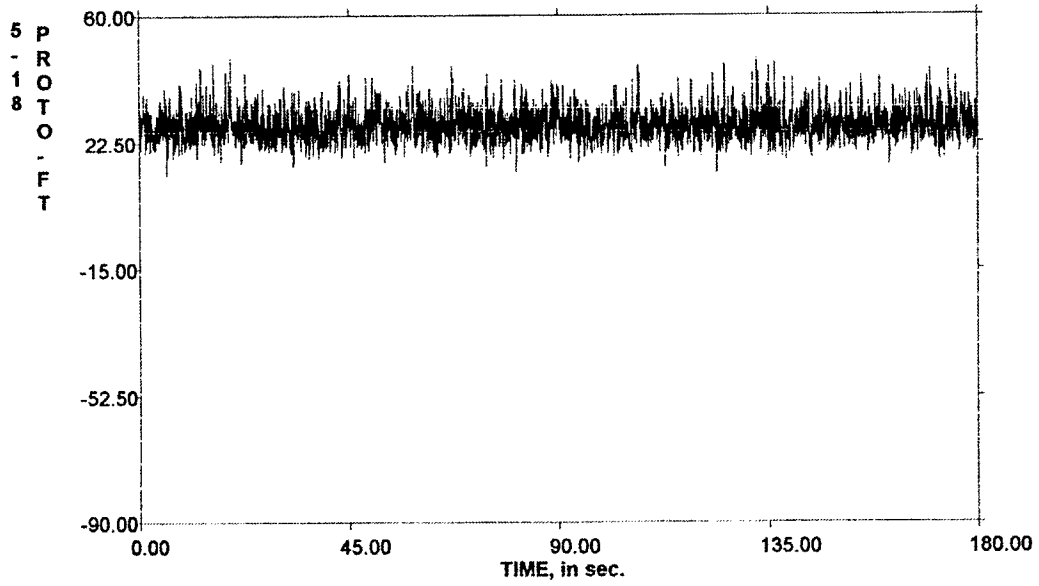

C:\WESDAQ1\BLUSTONE\C6-1, Channel Number 6

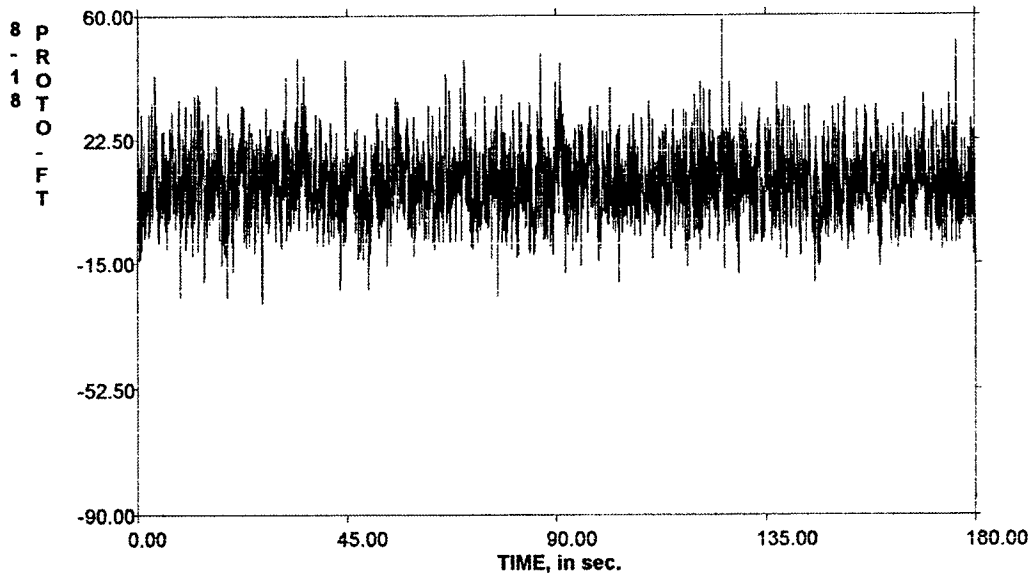

Information File Name: c:\wesdaq1\C6-2.inf
 Sample Rate: 50.000 samples/sec/channel
 Number of Seconds Recorded: 180.000 seconds
 Data Collected on 6/2/00 1:23:42 PM
 Bluestone Dam Model
 1:65 Scale
 Condition No. 6: Pool Elevation = 1520.2 Ft. Prototype
 All 6 channels filtered at 10 Hz. Low Pass
 All Calibrations and Data Recorded are in Prototype feet
 All channels are balanced and calibrated at 23.0 Ft. Prototype,
 Model Water Level at top of Stilling Weir.

ISDD Operator: Wallace Guy

STATISTICS						
CHAN	MINIMUM	AVERAGE	MAXIMUM	STANDARD	ROOT MEAN	ENGINEERING UNI
NUM	MEASUREMENT	MEASUREMENT	MEASUREMENT	DEVIATION	SQUARE	
1	18.966	35.206	54.817	4.450	35.486	PROTO-FT
2	-83.553	-53.083	-2.477	12.072	54.439	PROTO-FT
3	6.796	27.373	50.118	4.219	27.696	PROTO-FT
4	-26.245	-1.647	41.131	8.971	9.121	PROTO-FT
5	-61.988	-38.085	3.570	9.312	39.207	PROTO-FT
6	-33.471	9.439	56.796	9.693	13.530	PROTO-FT

CALIBRATION INFORMATION							
CHAN	GAIN	BASE	CALSTEP	BASE	CAL STEP	ENGINEERING UNITS	TYPE OF G
NUM		VOLTAGE	VOLTAGE	ENG VALUE	ENG VALUE		
1	1.0	-0.005	2.010	23.000	51.199	PROTO-FT	5-2
2	1.0	0.008	1.044	23.000	50.701	PROTO-FT	5-11
3	1.0	0.011	2.009	23.000	48.036	PROTO-FT	5-18
4	1.0	0.013	1.463	23.000	44.900	PROTO-FT	8-2
5	1.0	0.003	1.067	23.000	51.205	PROTO-FT	8-11
6	1.0	-0.010	1.835	23.000	58.566	PROTO-FT	8-18

C:\WESDAQ1\BLUSTONE\C6-2, Channel Number 1

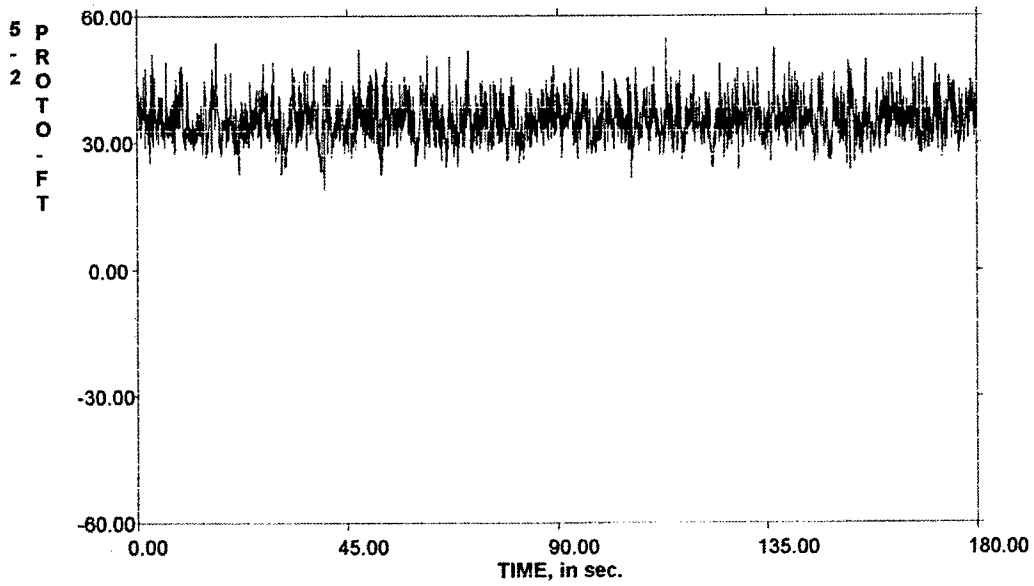

C:\WESDAQ1\BLUSTONE\C6-2, Channel Number 4

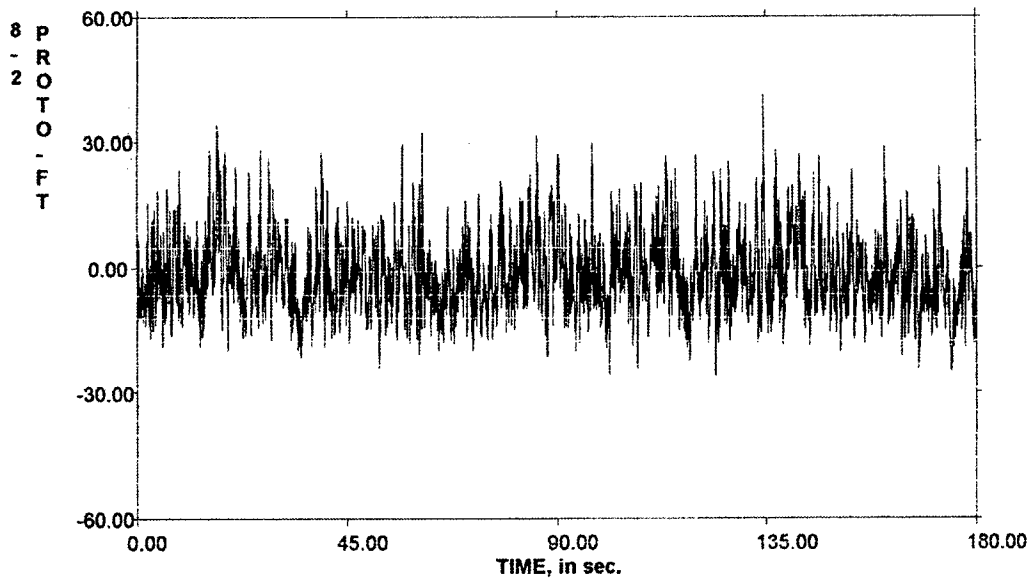

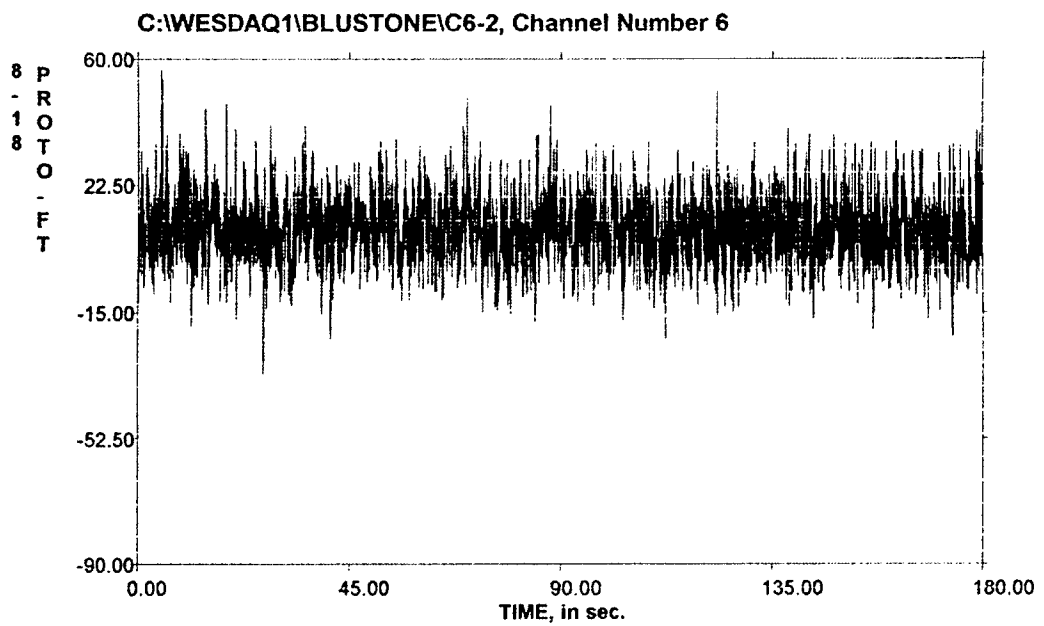
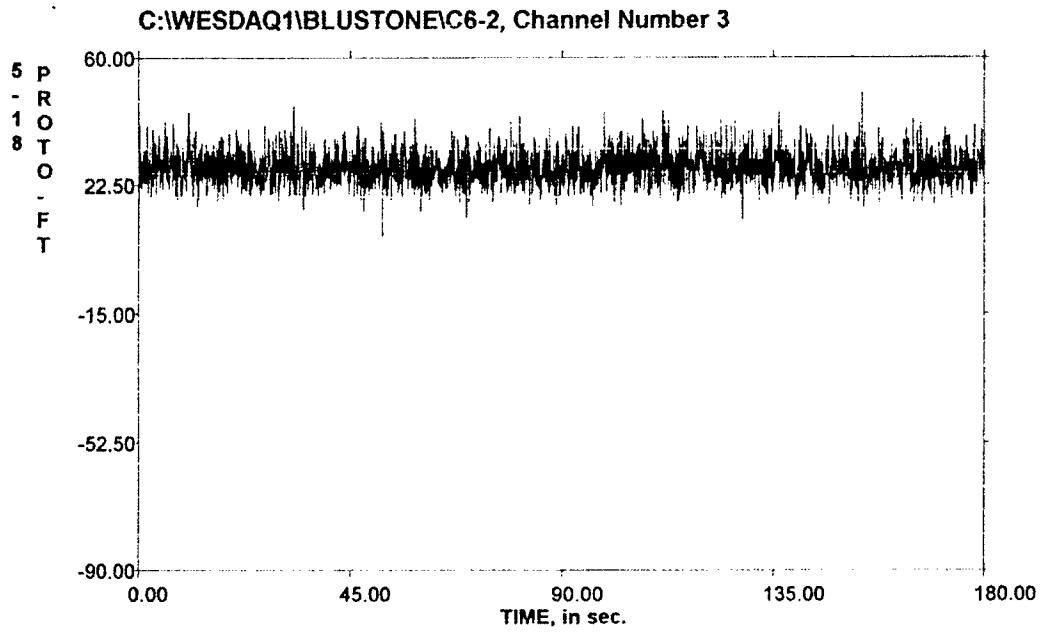

C:\WESDAQ1\BLUSTONE\C6-2, Channel Number 3

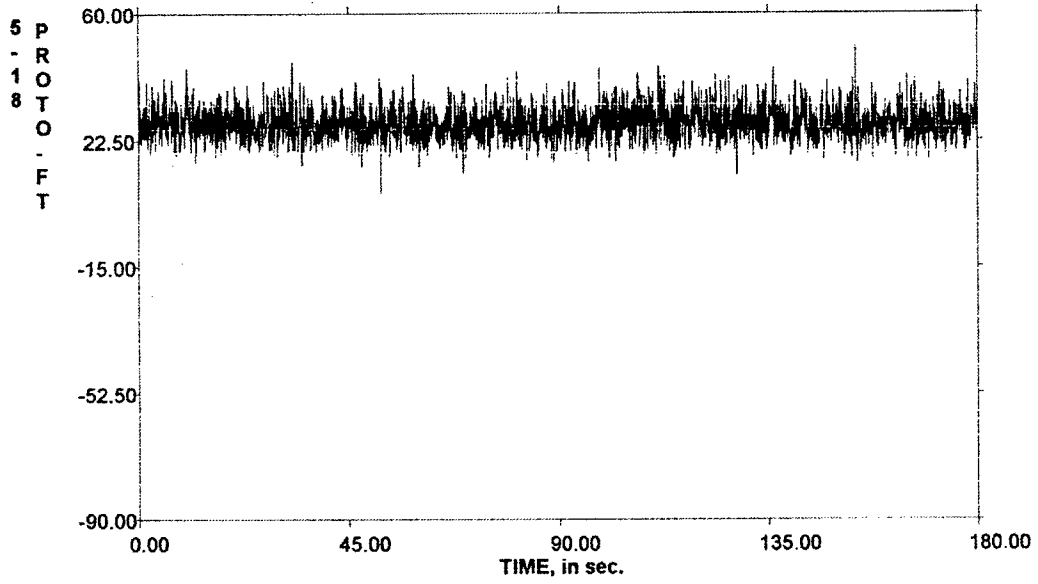

C:\WESDAQ1\BLUSTONE\C6-2, Channel Number 6

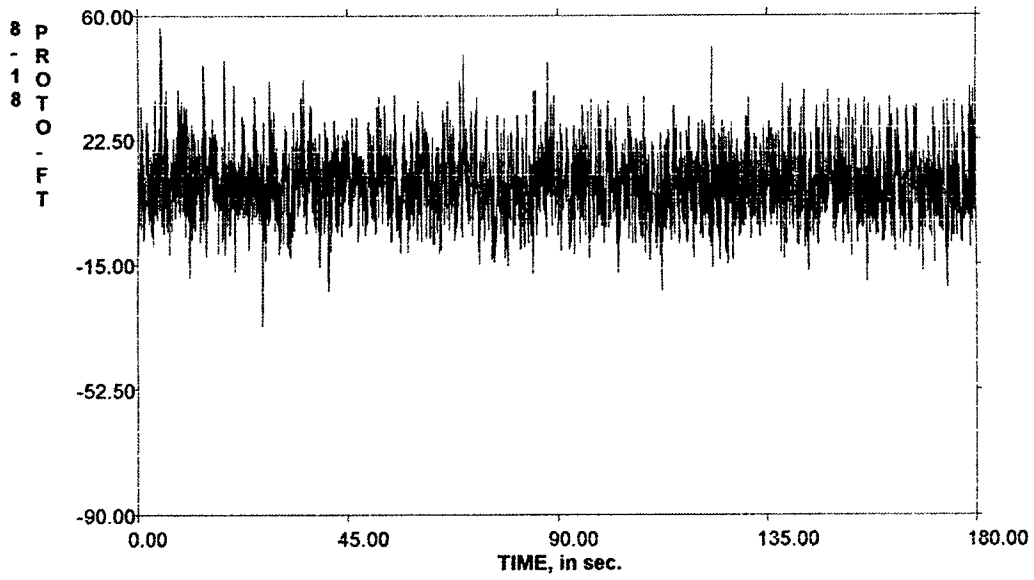

Information File Name: c:\wesdaq1\C6-3.inf
 Sample Rate: 50.000 samples/sec/channel
 Number of Seconds Recorded: 180.000 seconds
 Data Collected on 6/2/00 1:31:02 PM

Bluestone Dam Model
 1:65 Scale

Condition No. 6: Pool Elevation = 1520.2 Ft. Prototype
 All 6 channels filtered at 10 Hz. Low Pass
 All Calibrations and Data Recorded are in Prototype feet
 All channels are balanced and calibrated at 23.0 Ft. Prototype,
 Model Water Level at top of Stilling Weir.

ISDD Operator: Wallace Guy

STATISTICS						
CHAN	MINIMUM	AVERAGE	MAXIMUM	STANDARD	ROOT MEAN	ENGINEERING UNI
NUM	MEASUREMENT	MEASUREMENT	MEASUREMENT	DEVIATION	SQUARE	
1	19.889	35.017	53.074	4.236	35.272	PROTO-FT
2	-84.337	-52.817	0.069	12.234	54.215	PROTO-FT
3	7.622	27.064	47.579	4.181	27.385	PROTO-FT
4	-45.901	-1.732	33.718	8.678	8.849	PROTO-FT
5	-63.347	-38.382	-1.996	8.849	39.388	PROTO-FT
6	-29.565	9.083	56.372	9.922	13.452	PROTO-FT

CALIBRATION INFORMATION							
CHAN	GAIN	BASE	CALSTEP	BASE	CAL STEP	ENGINEERING UNITS	TYPE OF G
NUM		VOLTAGE	VOLTAGE	ENG VALUE	ENG VALUE		
1	1.0	-0.005	2.010	23.000	51.199	PROTO-FT	5-2
2	1.0	0.008	1.044	23.000	50.701	PROTO-FT	5-11
3	1.0	0.011	2.009	23.000	48.036	PROTO-FT	5-18
4	1.0	0.013	1.463	23.000	44.900	PROTO-FT	8-2
5	1.0	0.003	1.067	23.000	51.205	PROTO-FT	8-11
6	1.0	-0.010	1.835	23.000	58.566	PROTO-FT	8-18

C:\WESDAQ1\BLUSTONE\C6-3, Channel Number 1

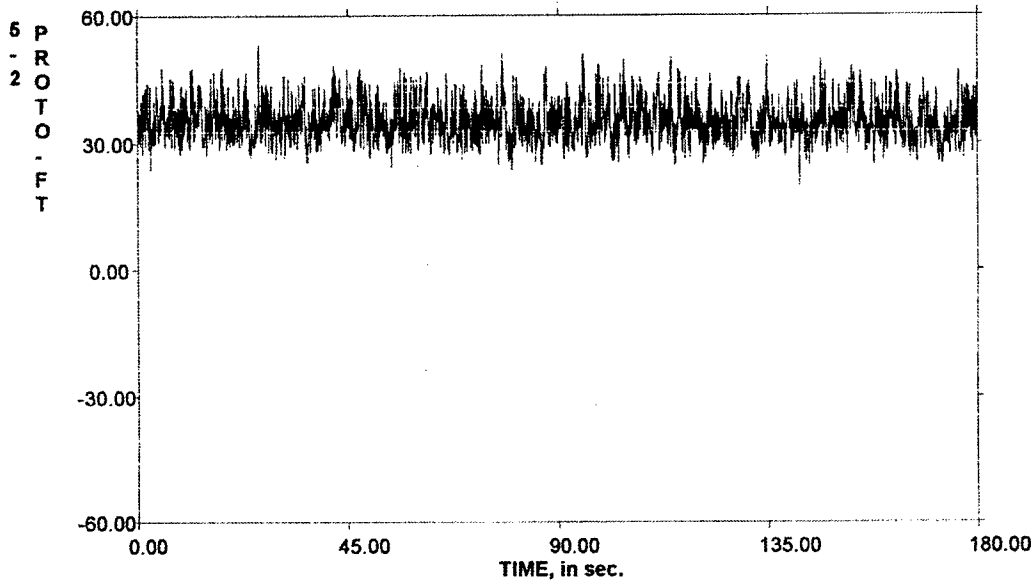

C:\WESDAQ1\BLUSTONE\C6-3, Channel Number 4

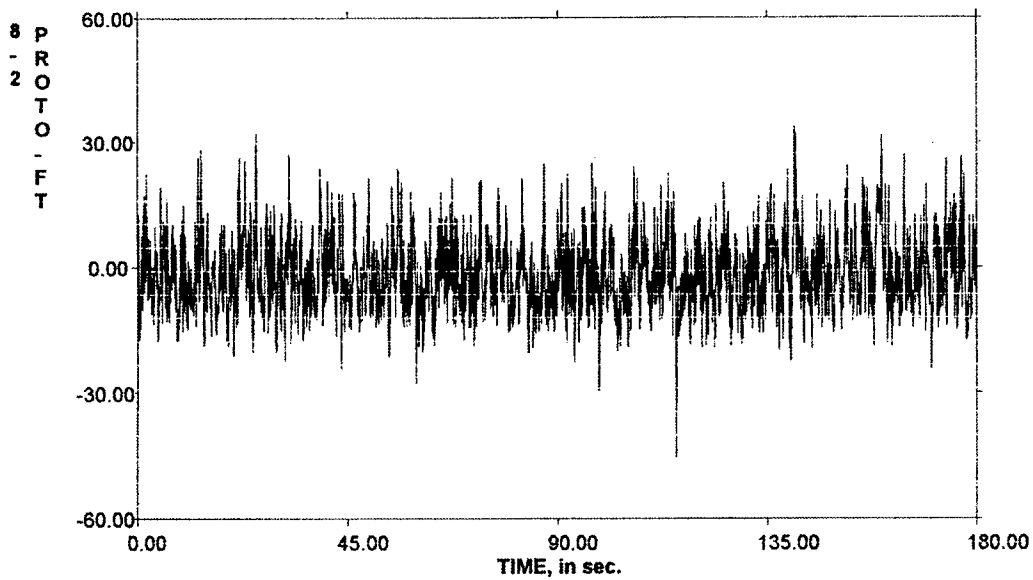

C:\WESDAQ1\BLUSTONE\C6-3, Channel Number 2

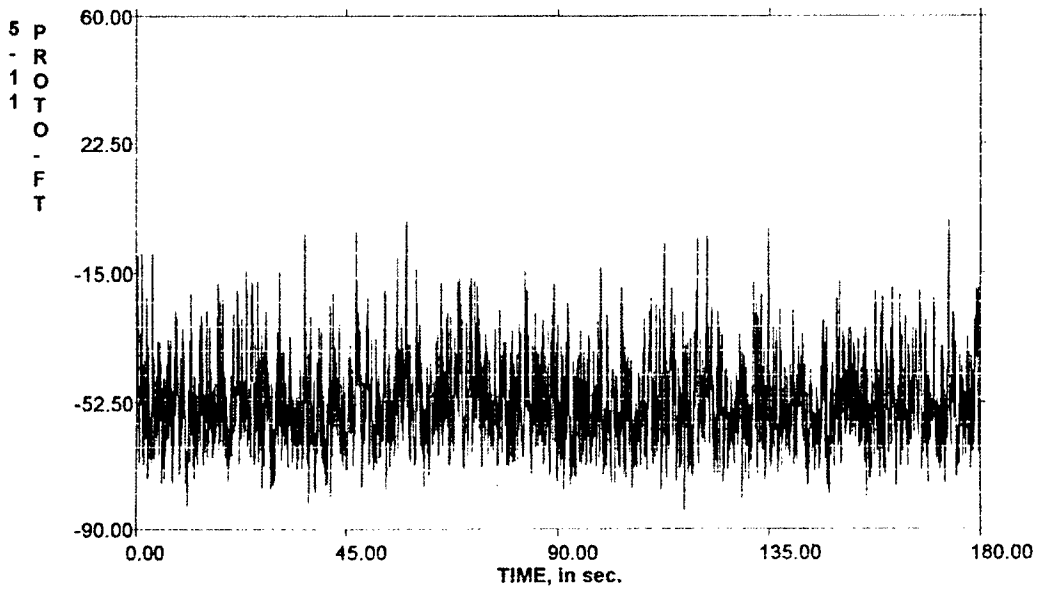

C:\WESDAQ1\BLUSTONE\C6-3, Channel Number 5

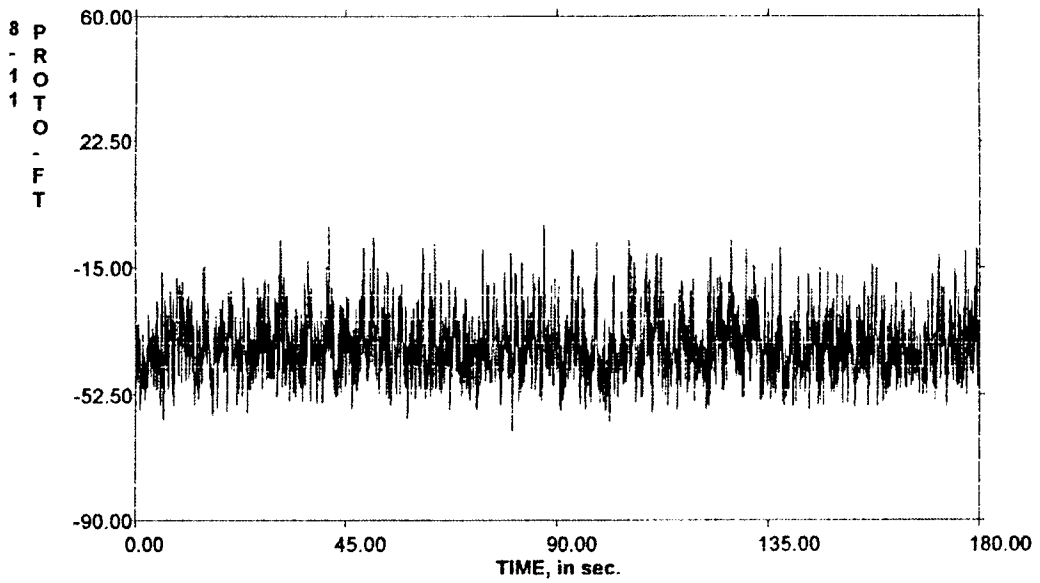

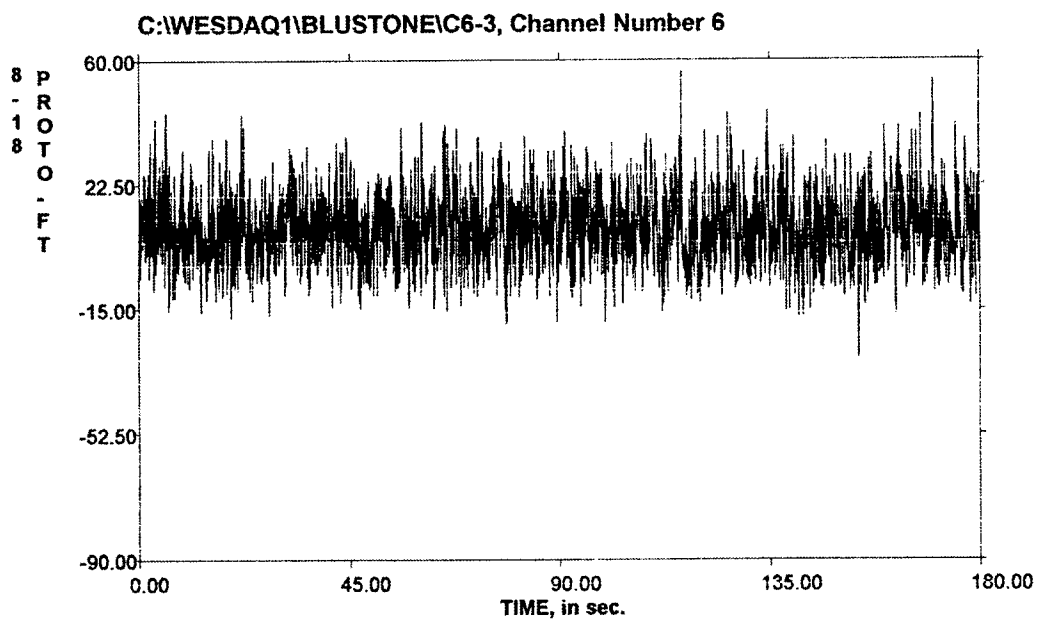
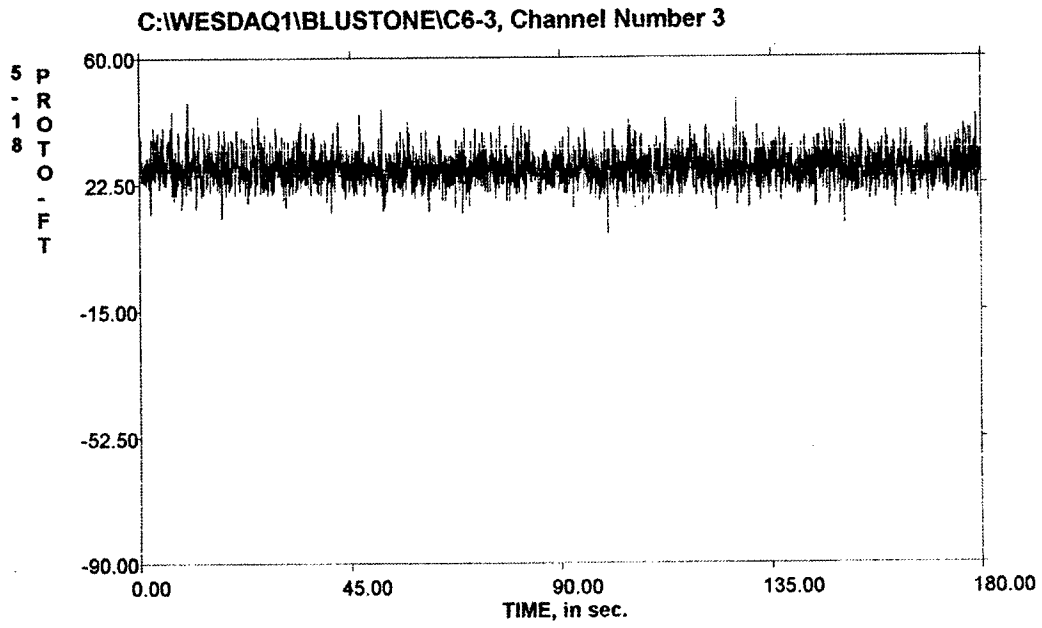

Information File Name: c:\wesdaq1\C7-1.inf
 Sample Rate: 50.000 samples/sec/channel
 Number of Seconds Recorded: 180.000 seconds
 Data Collected on 6/2/00 11:29:21 AM
 Bluestone Dam Model
 1:65 Scale
 Condition No. 7: Pool Elevation = 1524.8 Ft. Prototype
 All 6 channels filtered at 10 Hz. Low Pass
 All Calibrations and Data Recorded are in Prototype feet
 All channels are balanced and calibrated at 23.0 Ft. Prototype,
 Model Water Level at top of Stilling Weir.

ISDD Operator: Wallace Guy

STATISTICS						
CHAN	MINIMUM	AVERAGE	MAXIMUM	STANDARD	ROOT MEAN	ENGINEERING UNI
NUM	MEASUREMENT	MEASUREMENT	MEASUREMENT	DEVIATION	SQUARE	
1	12.849	30.015	51.536	4.963	30.422	PROTO-FT
2	-92.039	-71.067	-27.936	7.613	71.474	PROTO-FT
3	10.009	25.849	45.621	4.099	26.172	PROTO-FT
4	-52.724	-14.776	23.687	8.850	17.223	PROTO-FT
5	-73.314	-54.330	-17.851	5.683	54.627	PROTO-FT
6	-24.670	8.079	43.759	9.509	12.477	PROTO-FT

CALIBRATION INFORMATION							
CHAN	GAIN	BASE	CALSTEP	BASE	CAL STEP	ENGINEERING UNITS	TYPE OF G
NUM		VOLTAGE	VOLTAGE	ENG VALUE	ENG VALUE		
1	1.0	-0.005	2.010	23.000	51.199	PROTO-FT	5-2
2	1.0	0.008	1.044	23.000	50.701	PROTO-FT	5-11
3	1.0	0.011	2.009	23.000	48.036	PROTO-FT	5-18
4	1.0	0.013	1.463	23.000	44.900	PROTO-FT	8-2
5	1.0	0.003	1.067	23.000	51.205	PROTO-FT	8-11
6	1.0	-0.010	1.835	23.000	58.566	PROTO-FT	8-18

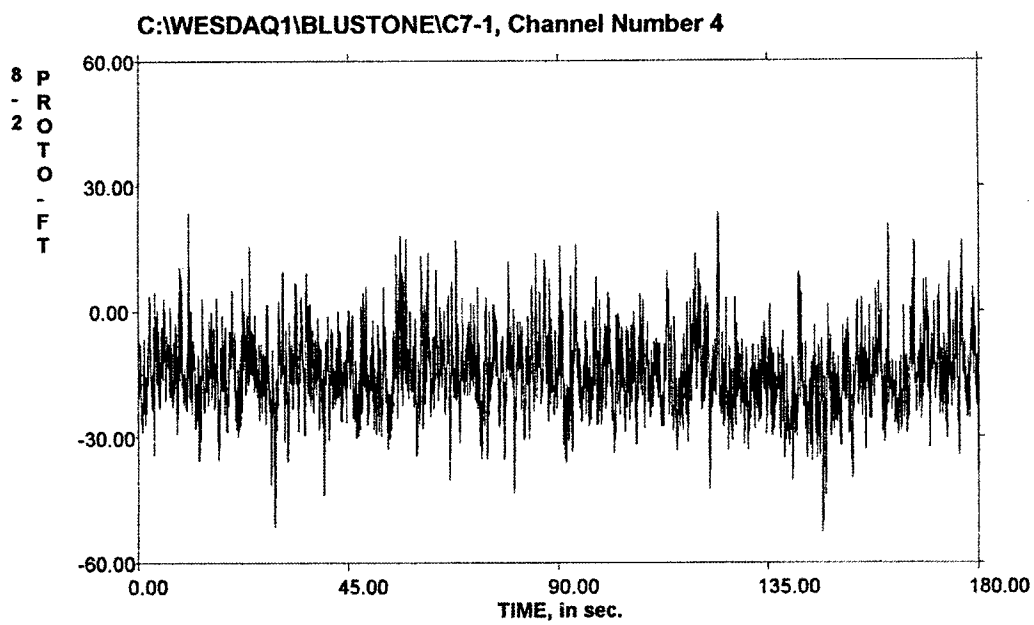
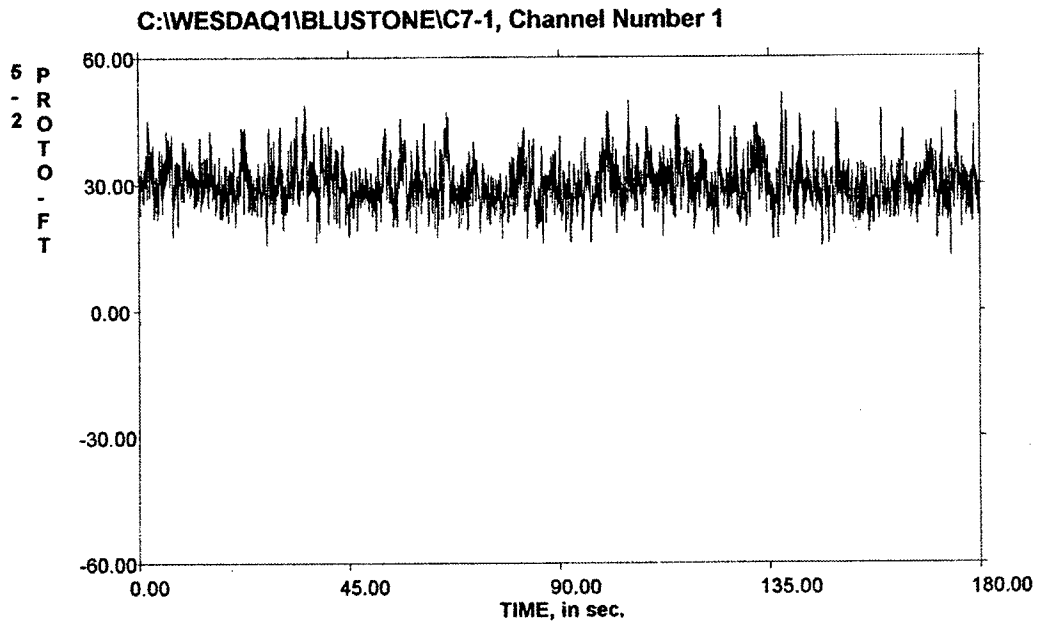

C:\WESDAQ1\BLUSTONE\C7-1, Channel Number 2

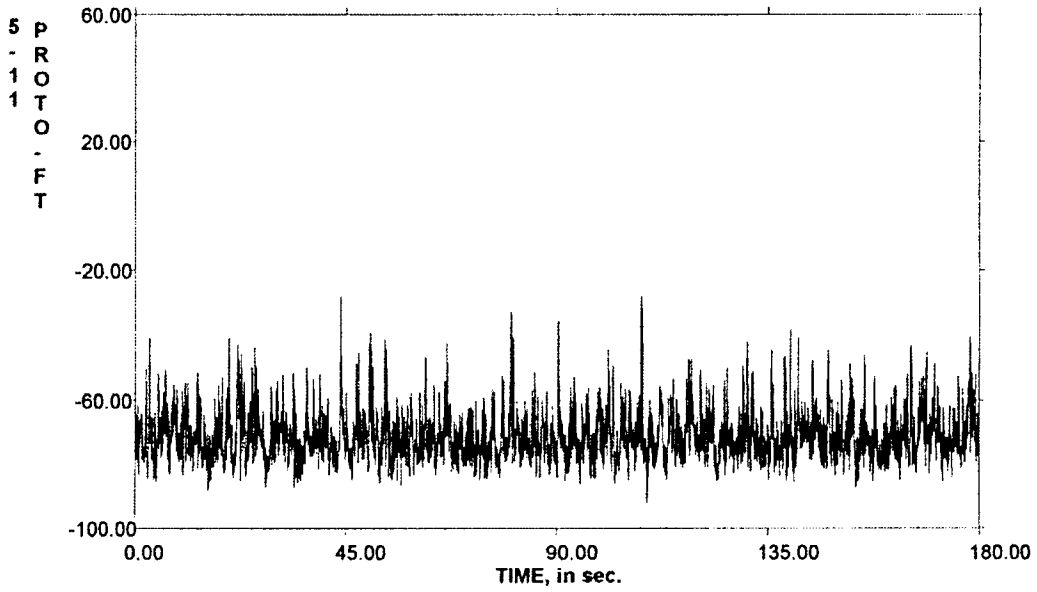

C:\WESDAQ1\BLUSTONE\C7-1, Channel Number 5

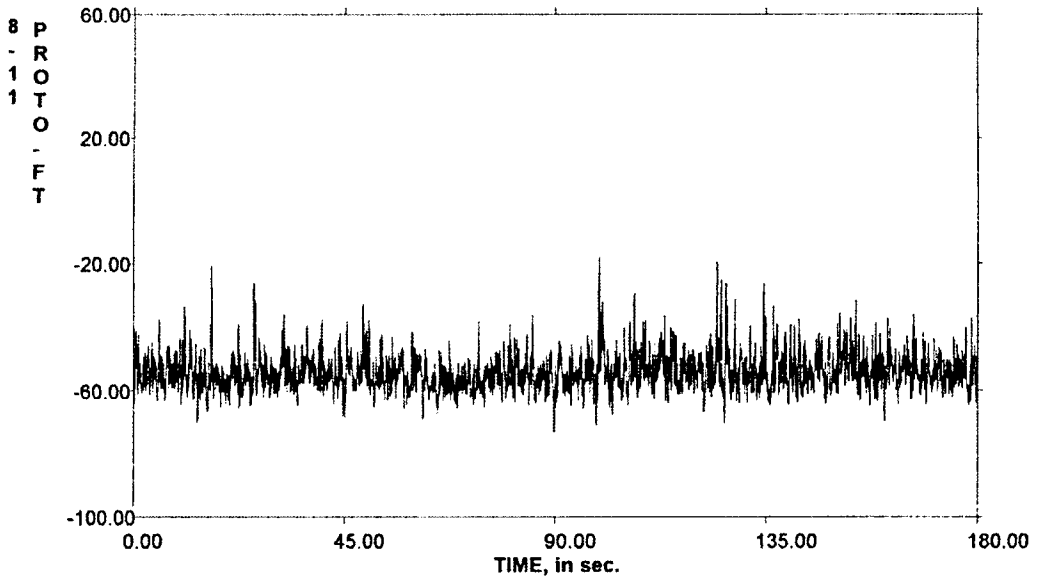

C:\WESDAQ1\BLUSTONEIC7-1, Channel Number 3

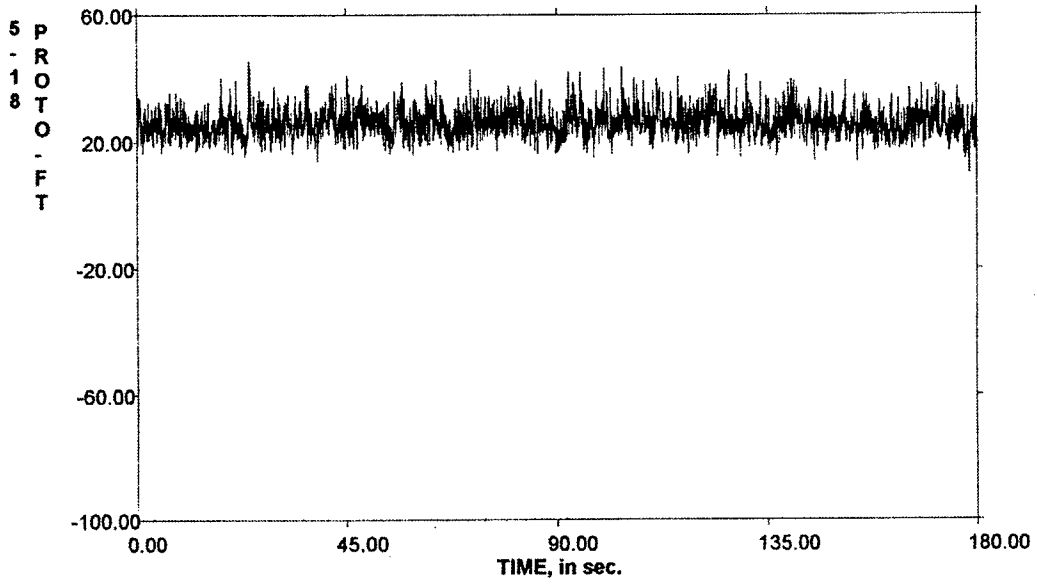

C:\WESDAQ1\BLUSTONEIC7-1, Channel Number 6

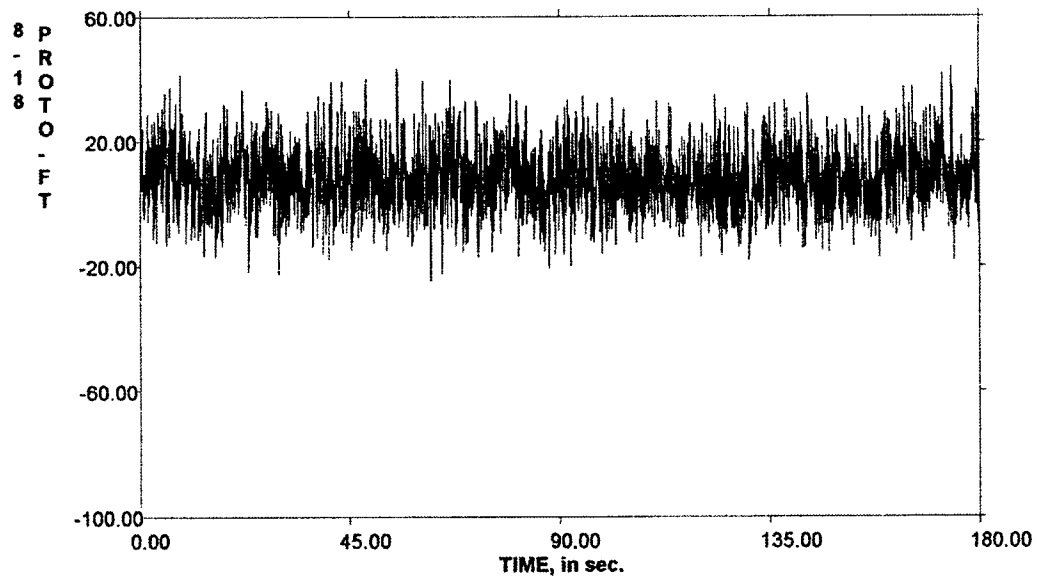

Information File Name: c:\wesdaq1\C7-2.inf
 Sample Rate: 50.000 samples/sec/channel
 Number of Seconds Recorded: 180.000 seconds
 Data Collected on 6/2/00 11:43:37 AM
 Bluestone Dam Model
 1:65 Scale
 Condition No. 7: Pool Elevation = 1524.8 Ft. Prototype
 All 6 channels filtered at 10 Hz. Low Pass
 All Calibrations and Data Recorded are in Prototype feet
 All channels are balanced and calibrated at 23.0 Ft. Prototype,
 Model Water Level at top of Stilling Weir.

ISDD Operator: Wallace Guy

STATISTICS						
CHAN	MINIMUM	AVERAGE	MAXIMUM	STANDARD	ROOT MEAN	ENGINEERING UNI
NUM	MEASUREMENT	MEASUREMENT	MEASUREMENT	DEVIATION	SQUARE	
1	11.003	29.175	51.707	4.729	29.556	PROTO-FT
2	-90.277	-71.100	-17.752	7.616	71.506	PROTO-FT
3	11.936	25.469	45.682	4.099	25.797	PROTO-FT
4	-52.724	-14.860	22.065	8.570	17.154	PROTO-FT
5	-70.596	-54.486	-11.056	5.858	54.800	PROTO-FT
6	-24.341	7.474	51.431	9.674	12.224	PROTO-FT

CALIBRATION INFORMATION							
CHAN	GAIN	BASE	CALSTEP	BASE	CAL STEP	ENGINEERING UNITS	TYPE OF G
NUM		VOLTAGE	VOLTAGE	ENG VALUE	ENG VALUE		
1	1.0	-0.005	2.010	23.000	51.199	PROTO-FT	5-2
2	1.0	0.008	1.044	23.000	50.701	PROTO-FT	5-11
3	1.0	0.011	2.009	23.000	48.036	PROTO-FT	5-18
4	1.0	0.013	1.463	23.000	44.900	PROTO-FT	8-2
5	1.0	0.003	1.067	23.000	51.205	PROTO-FT	8-11
6	1.0	-0.010	1.835	23.000	58.566	PROTO-FT	8-18

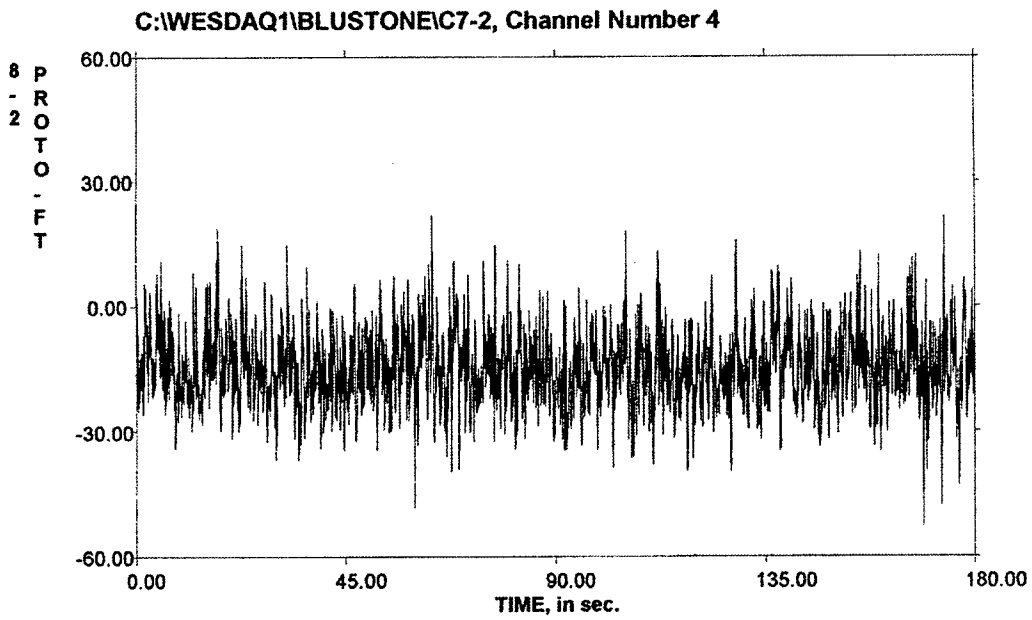
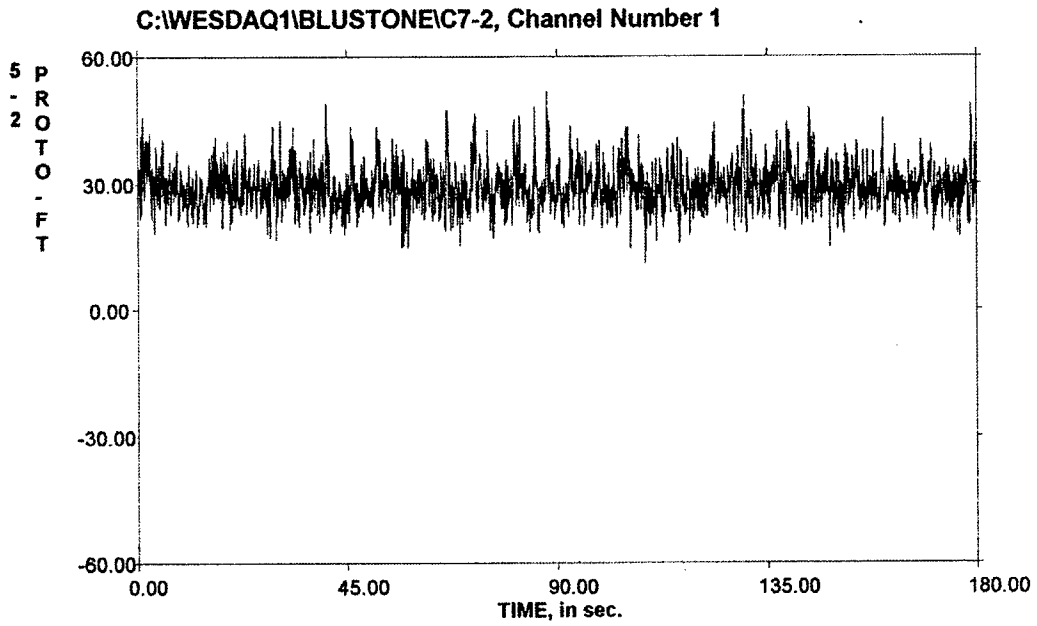

C:\WESDAQ1\BLUSTONE\C7-2, Channel Number 2

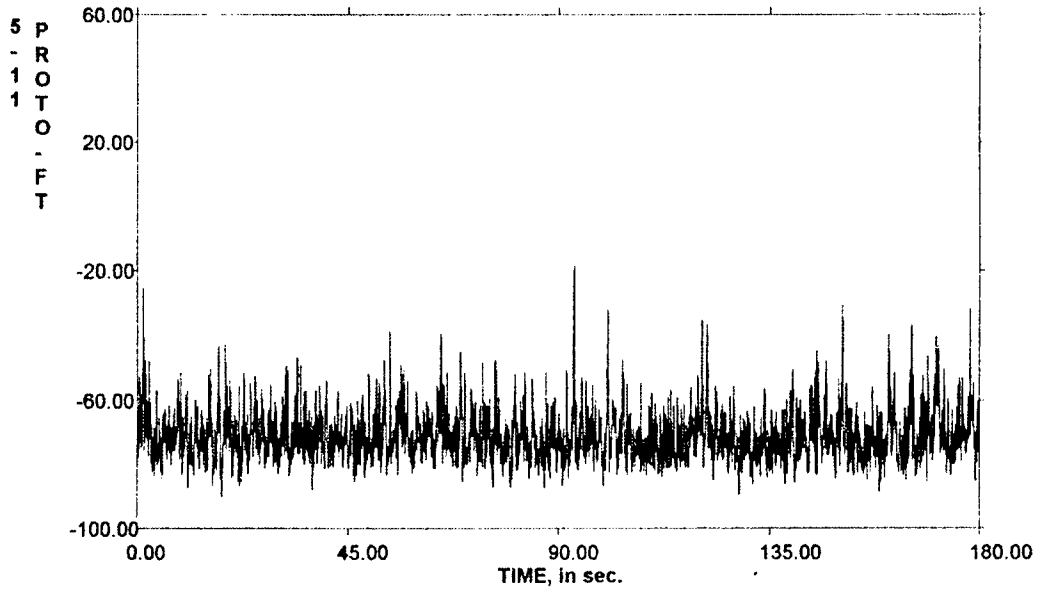

C:\WESDAQ1\BLUSTONE\C7-2, Channel Number 5

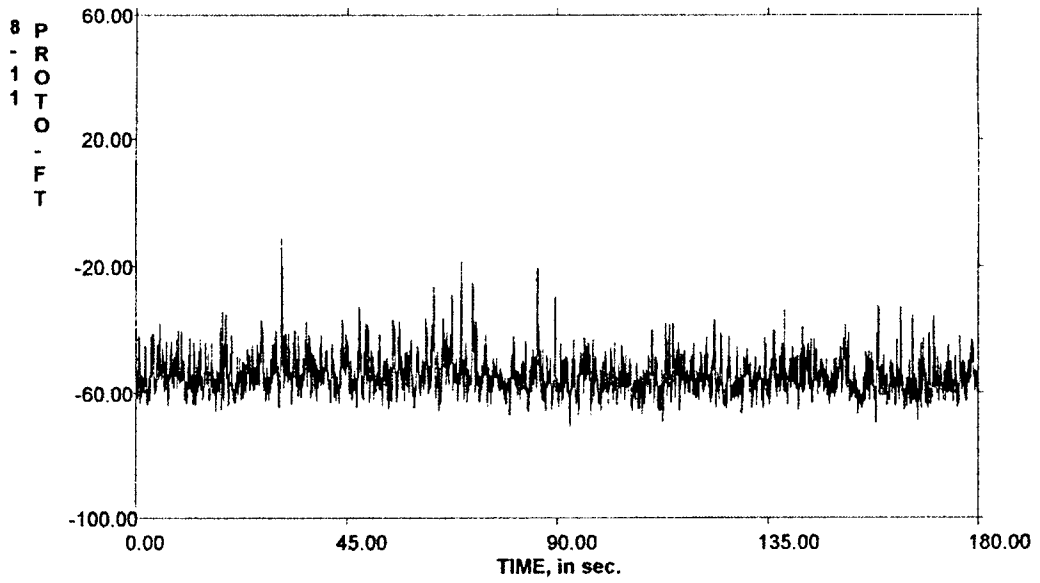

C:\WESDAQ1\BLUSTONE\C7-2, Channel Number 3

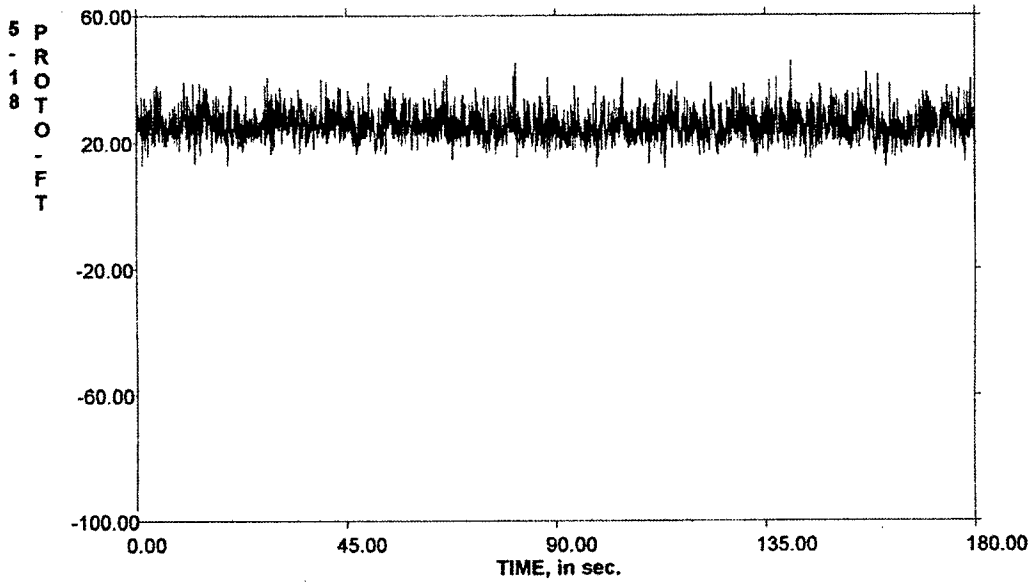

C:\WESDAQ1\BLUSTONE\C7-2, Channel Number 6

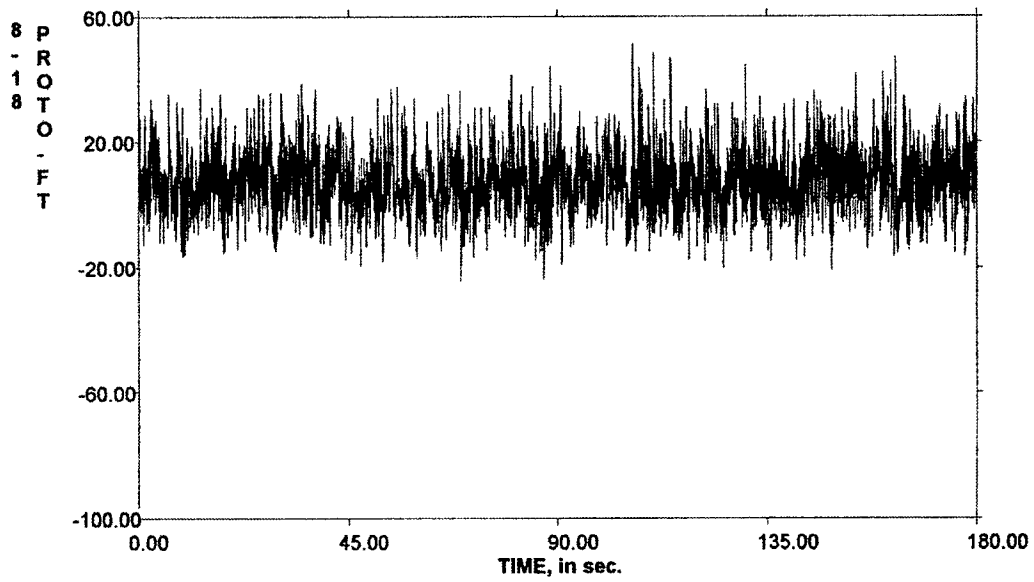

Information File Name: c:\wesdaq1\C7-3.inf
 Sample Rate: 50.000 samples/sec/channel
 Number of Seconds Recorded: 180.000 seconds
 Data Collected on 6/2/00 12:34:33 PM

Bluestone Dam Model
 1:65 Scale

Condition No. 7: Pool Elevation = 1524.8 Ft. Prototype
 All 6 channels filtered at 10 Hz. Low Pass
 All Calibrations and Data Recorded are in Prototype feet
 All channels are balanced and calibrated at 23.0 Ft. Prototype,
 Model Water Level at top of Stilling Weir.

ISDD Operator: Wallace Guy

STATISTICS						
CHAN	MINIMUM	AVERAGE	MAXIMUM	STANDARD	ROOT MEAN	ENGINEERING UNI
NUM	MEASUREMENT	MEASUREMENT	MEASUREMENT	DEVIATION	SQUARE	
1	8.987	29.261	49.793	4.806	29.653	PROTO-FT
2	-89.951	-70.892	-21.669	8.293	71.376	PROTO-FT
3	12.456	25.331	41.613	3.953	25.638	PROTO-FT
4	-52.724	-15.206	20.405	8.954	17.647	PROTO-FT
5	-71.955	-54.554	-21.152	5.468	54.827	PROTO-FT
6	-33.047	6.917	50.301	9.290	11.582	PROTO-FT

CALIBRATION INFORMATION						
CHAN	GAIN	BASE CALSTEP	BASE	CAL STEP	ENGINEERING UNITS	TYPE OF G
NUM		VOLTAGE	VOLTAGE	ENG VALUE	ENG VALUE	
1	1.0	-0.005	2.010	23.000	51.199	PROTO-FT 5-2
2	1.0	0.008	1.044	23.000	50.701	PROTO-FT 5-11
3	1.0	0.011	2.009	23.000	48.036	PROTO-FT 5-18
4	1.0	0.013	1.463	23.000	44.900	PROTO-FT 8-2
5	1.0	0.003	1.067	23.000	51.205	PROTO-FT 8-11
6	1.0	-0.010	1.835	23.000	58.566	PROTO-FT 8-18

C:\WESDAQ1\BLUSTONEIC7-3, Channel Number 1

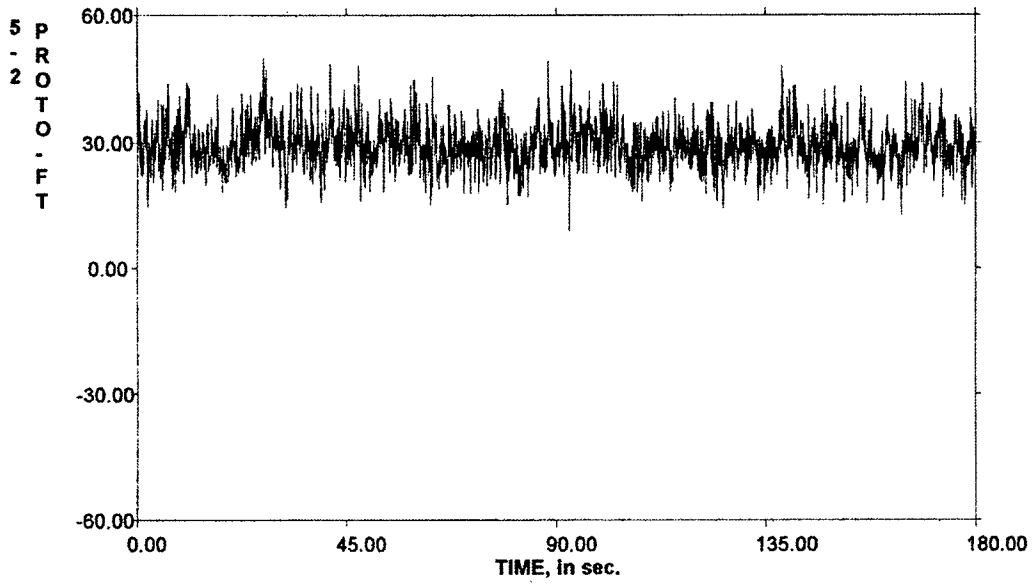

C:\WESDAQ1\BLUSTONEIC7-3, Channel Number 4

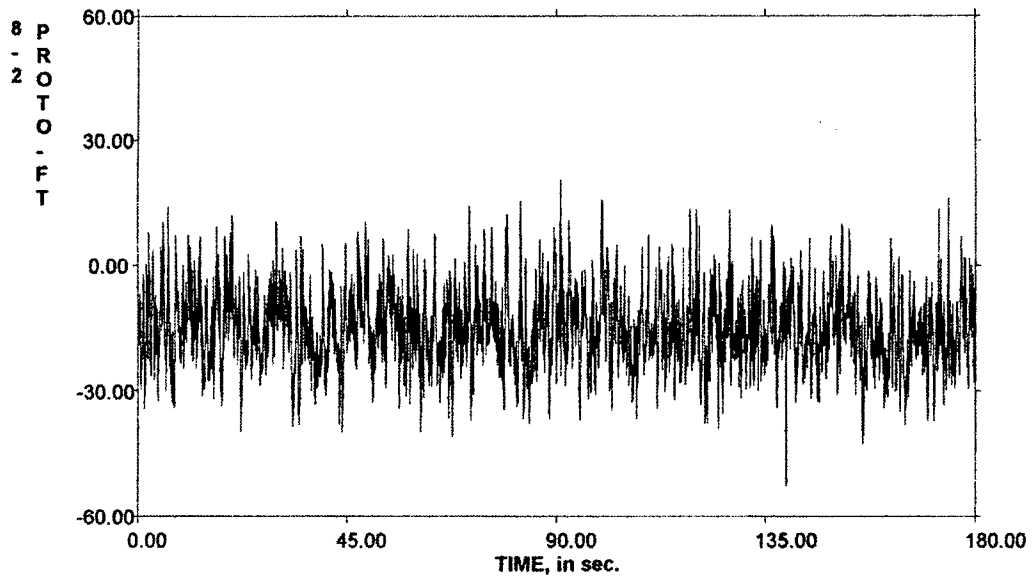

C:\WESDAQ1\BLUSTONE\C7-3, Channel Number 2

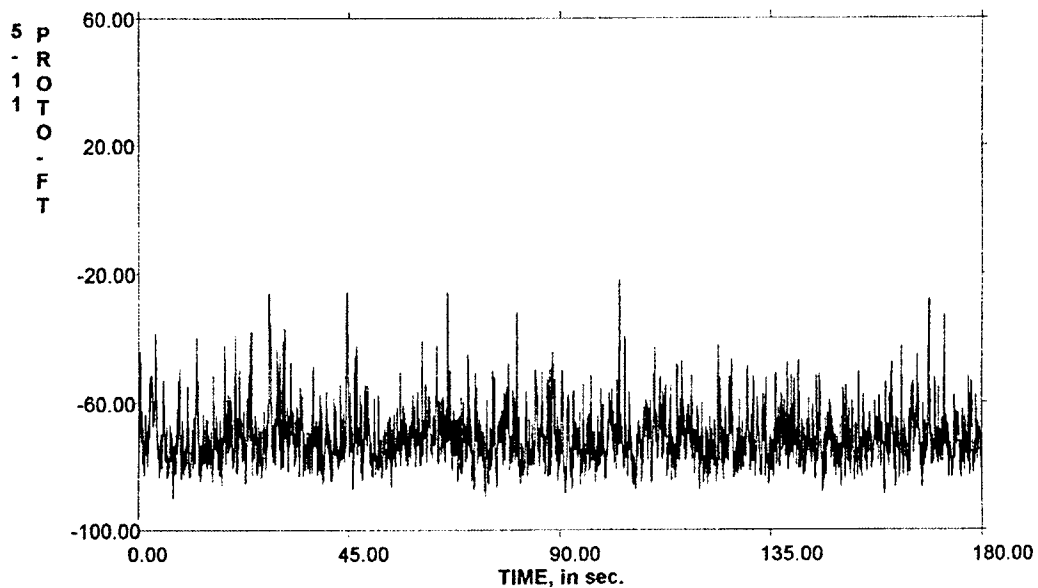

C:\WESDAQ1\BLUSTONE\C7-3, Channel Number 5

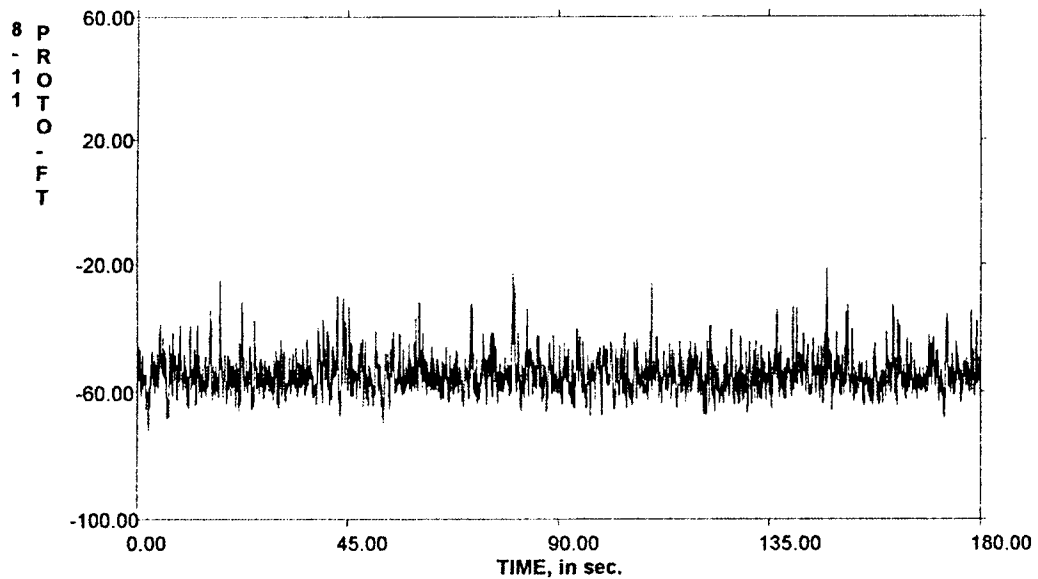

C:\WESDAQ1\BLUSTONE\C7-3, Channel Number 3

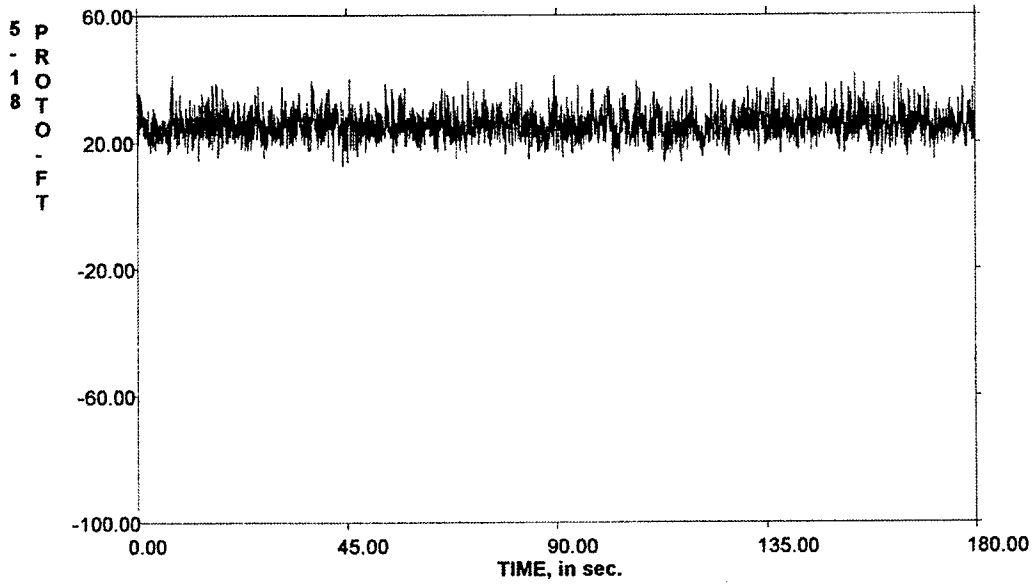

C:\WESDAQ1\BLUSTONE\C7-3, Channel Number 6

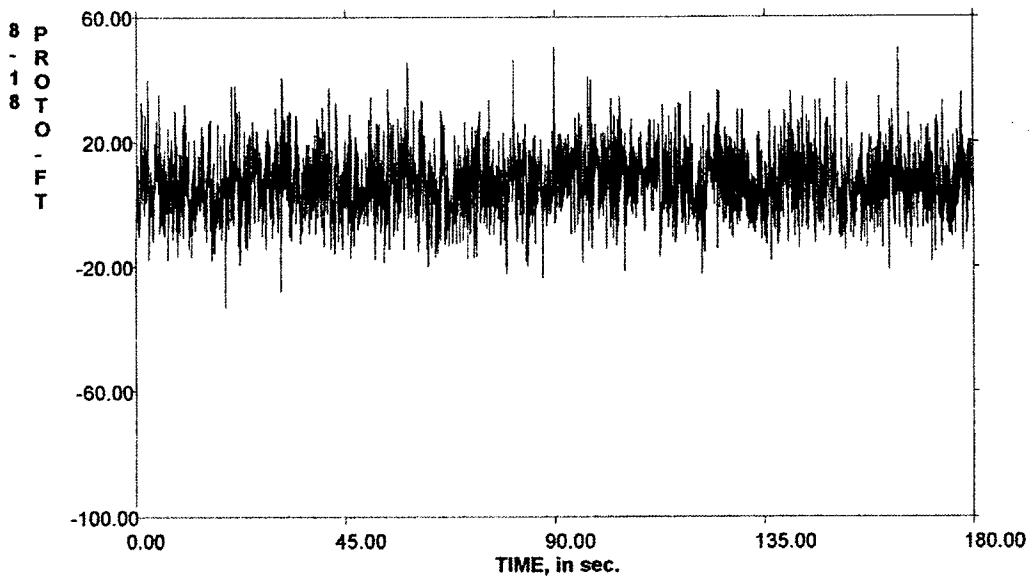

Information File Name: c:\wesdaq1\C7-4.inf
 Sample Rate: 50.000 samples/sec/channel
 Number of Seconds Recorded: 90.000 seconds
 Data Collected on 6/2/00 1:00:57 PM

Bluestone Dam Model
 1:65 Scale

Condition No. 7: Pool Elevation = 1524.8 Ft. Prototype
 All 6 channels filtered at 10 Hz. Low Pass
 All Calibrations and Data Recorded are in Prototype feet
 All channels are balanced and calibrated at 23.0 Ft. Prototype,
 Model Water Level at top of Stilling Weir.

ISDD Operator: Wallace Guy

CHAN NUM	STATISTICS					ROOT MEAN SQUARE	ENGINEERING UNI PROTO-FT
	MINIMUM MEASUREMENT	AVERAGE MEASUREMENT	MAXIMUM MEASUREMENT	STANDARD DEVIATION			
1	3.450	27.146	45.214	4.624		27.537	PROTO-FT
2	-89.885	-72.255	-28.001	8.159		72.715	PROTO-FT
3	8.999	23.102	39.349	4.050		23.455	PROTO-FT
4	-45.053	-17.040	16.939	8.391		18.994	PROTO-FT
5	-70.660	-55.497	-30.795	5.286		55.748	PROTO-FT
6	-22.788	4.978	46.865	9.440		10.672	PROTO-FT

CHAN NUM	GAIN	CALIBRATION INFORMATION				ENGINEERING UNITS	TYPE OF G
		BASE VOLTAGE	CALSTEP VOLTAGE	BASE ENG VALUE	CAL STEP ENG VALUE		
1	1.0	-0.005	2.010	23.000	51.199	PROTO-FT	5-2
2	1.0	0.008	1.044	23.000	50.701	PROTO-FT	5-11
3	1.0	0.011	2.009	23.000	48.036	PROTO-FT	5-18
4	1.0	0.013	1.463	23.000	44.900	PROTO-FT	8-2
5	1.0	0.003	1.067	23.000	51.205	PROTO-FT	8-11
6	1.0	-0.010	1.835	23.000	58.566	PROTO-FT	8-18

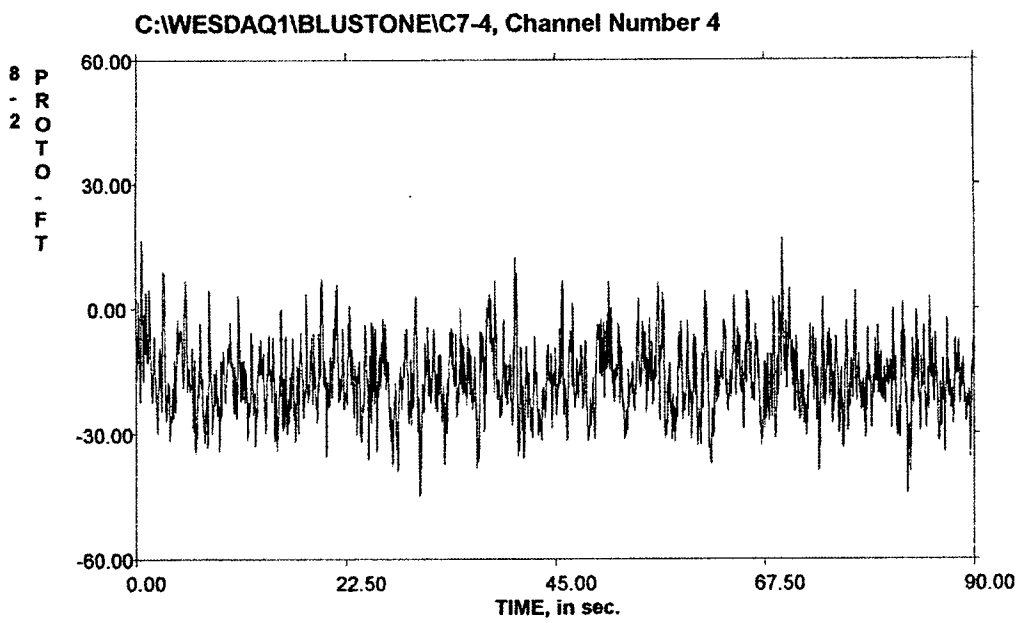
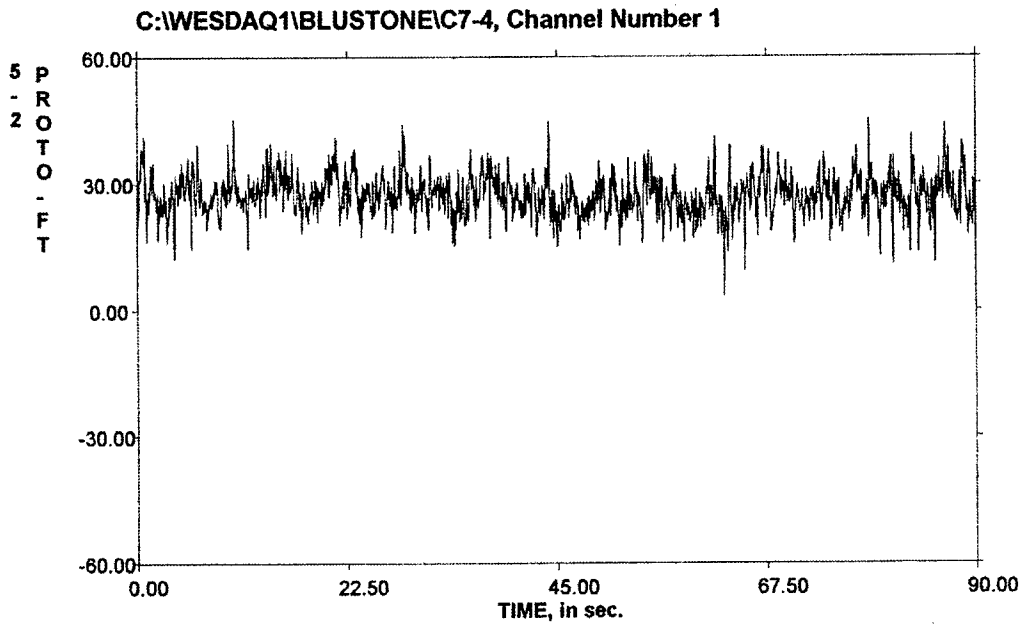

C:\WESDAQ1\BLUSTONE\C7-4, Channel Number 2

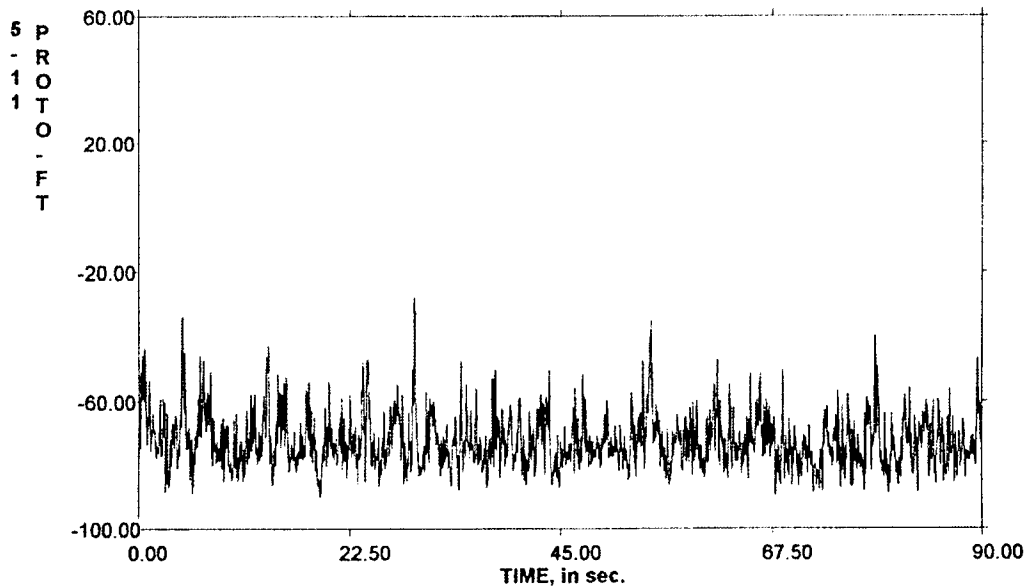

C:\WESDAQ1\BLUSTONE\C7-4, Channel Number 5

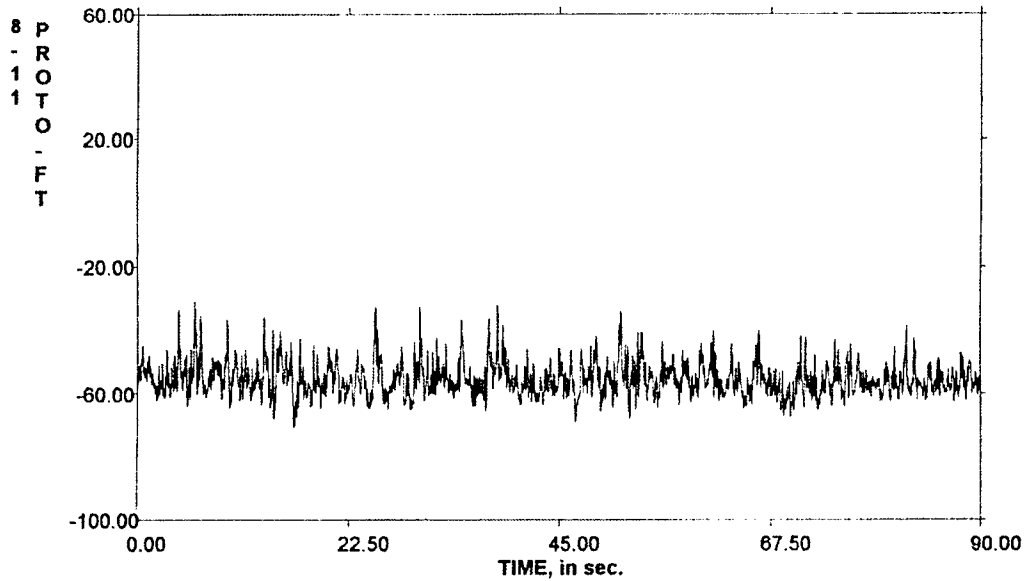

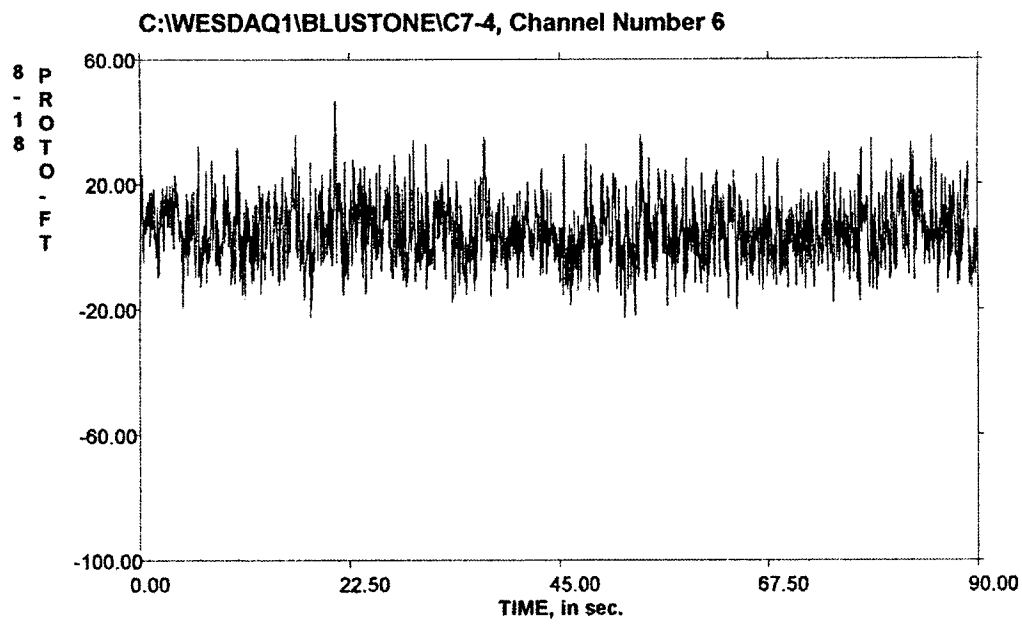
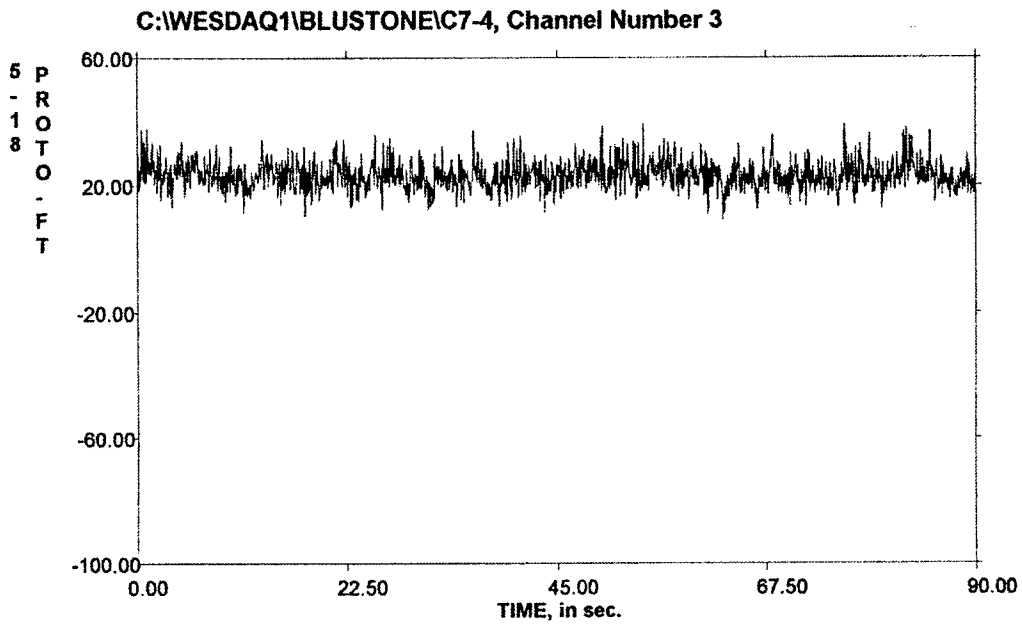

Information File Name: c:\wesdaq1\C8-5.inf
 Sample Rate: 50.000 samples/sec/channel
 Number of Seconds Recorded: 180.000 seconds
 Data Collected on 6/5/00 11:41:26 AM
 Bluestone Dam Model
 1:65 Scale
 Condition No. 8: Pool Elevation = 1531.2 Prototype Ft.
 All 6 channels filtered at 10 Hz. Low Pass
 All Calibrations and Data Recorded are in Prototype feet
 All channels are balanced and calibrated at 23.0 Ft. Prototype,
 Model Water Level at top of Stilling Weir.

ISDD Operator: Wallace Guy

STATISTICS						
CHAN	MINIMUM	AVERAGE	MAXIMUM	STANDARD	ROOT MEAN	ENGINEERING UNI
NUM	MEASUREMENT	MEASUREMENT	MEASUREMENT	DEVIATION	SQUARE	
1	-2.672	32.715	67.279	8.453	33.790	PROTO-FT
2	-113.053	-89.051	-43.628	10.089	89.621	PROTO-FT
3	-25.745	-14.946	-2.414	3.127	15.270	PROTO-FT
4	-55.237	-18.776	19.144	9.479	21.033	PROTO-FT
5	-90.337	-70.713	-35.496	6.600	71.020	PROTO-FT
6	-46.023	-25.080	10.239	5.671	25.713	PROTO-FT

CALIBRATION INFORMATION							
CHAN	GAIN	BASE	CALSTEP	BASE	CAL STEP	ENGINEERING UNITS	TYPE OF G
NUM		VOLTAGE	VOLTAGE	ENG VALUE	ENG VALUE		
1	1.0	0.005	2.006	23.000	51.199	PROTO-FT	5-2
2	1.0	-0.005	1.012	23.000	50.701	PROTO-FT	5-11
3	1.0	-0.006	2.006	23.000	48.036	PROTO-FT	5-18
4	1.0	0.005	1.406	23.000	44.900	PROTO-FT	8-2
5	1.0	0.006	1.013	23.000	51.205	PROTO-FT	8-11
6	1.0	0.005	1.999	23.000	58.566	PROTO-FT	8-18

C:\WESDAQ1\BLUSTONE\C8-5, Channel Number 1

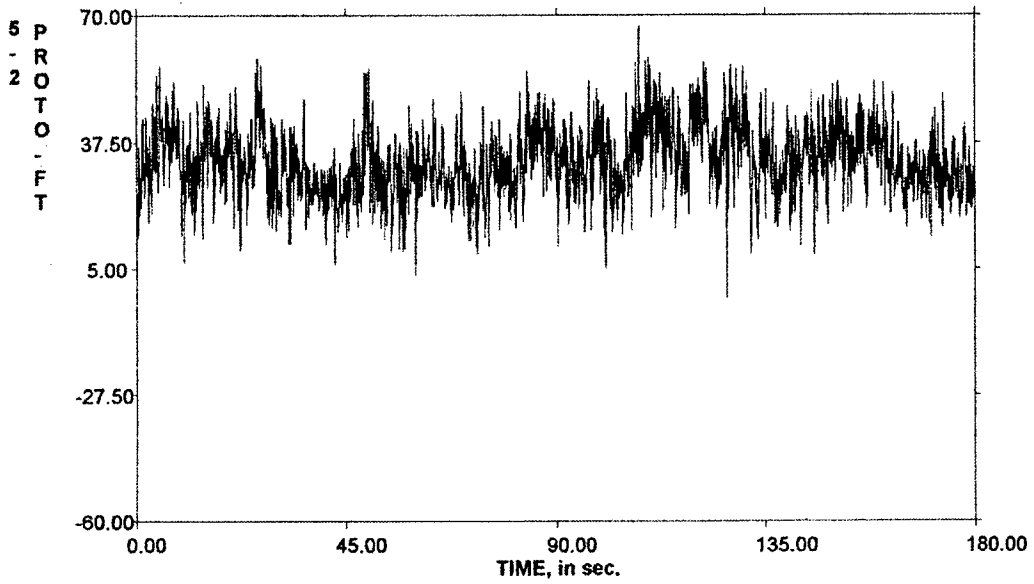

C:\WESDAQ1\BLUSTONE\C8-5, Channel Number 4

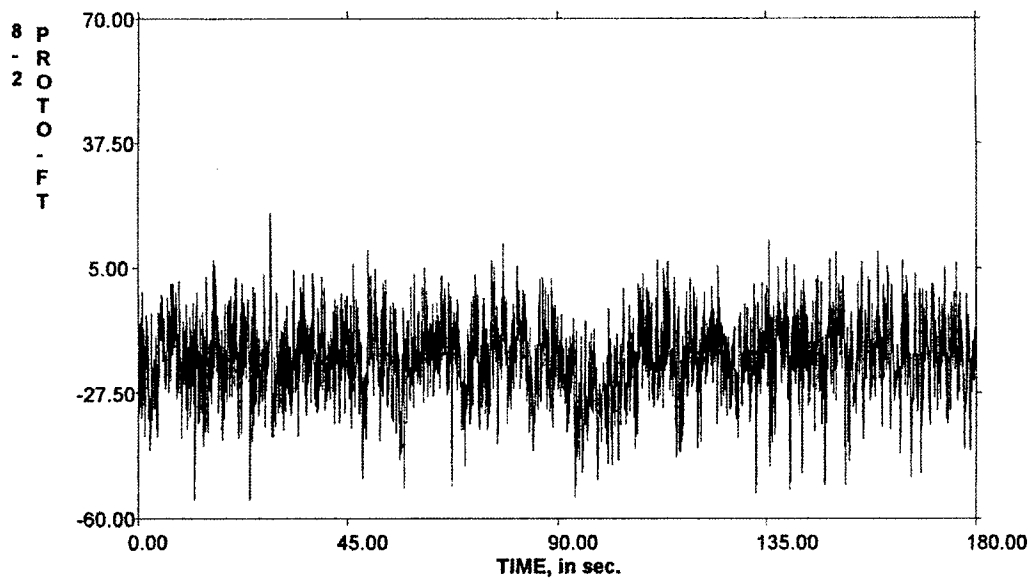

C:\WESDAQ1\BLUSTONE\C8-5, Channel Number 2

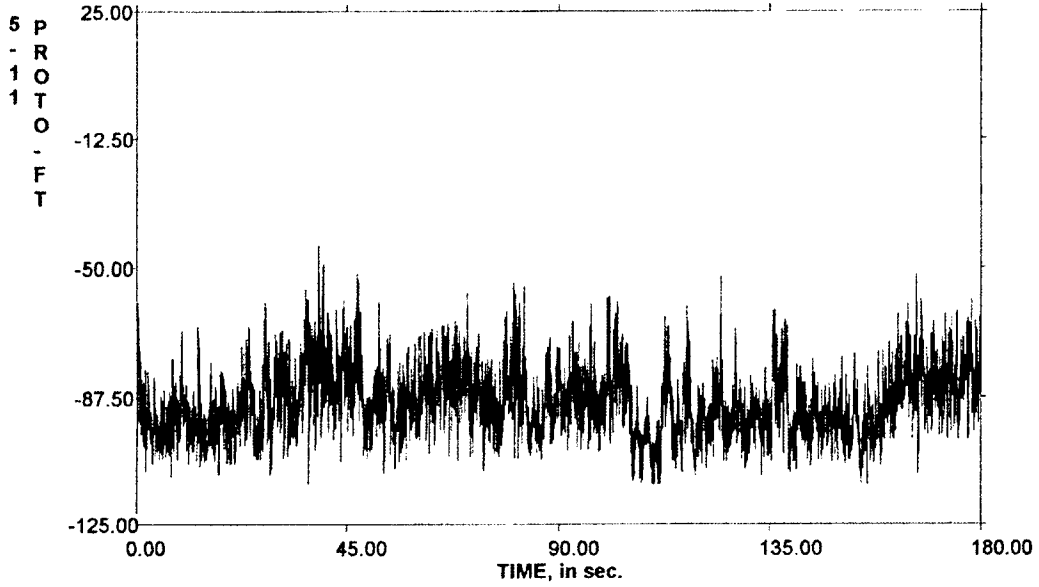

C:\WESDAQ1\BLUSTONE\C8-5, Channel Number 5

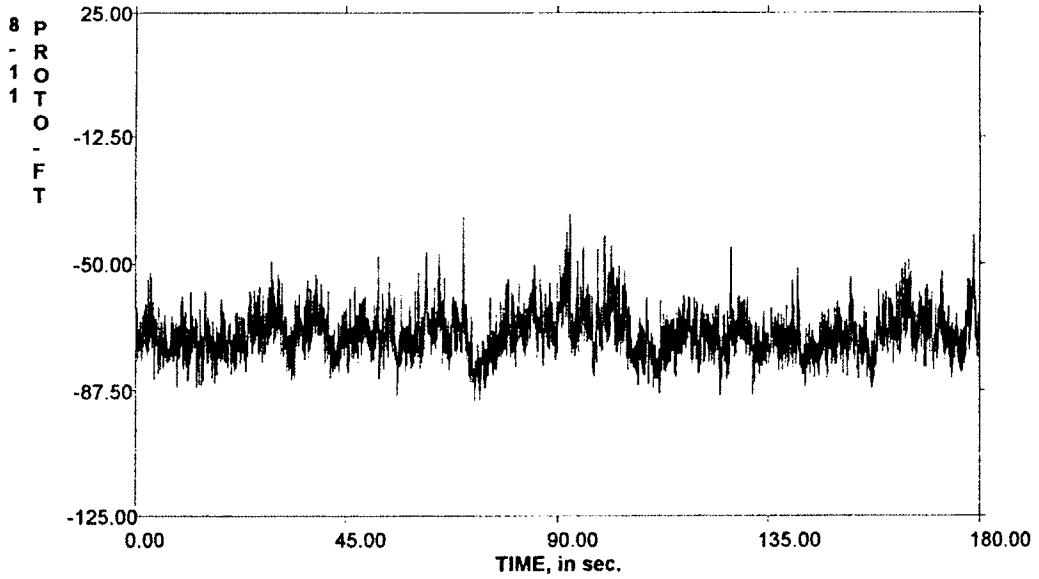

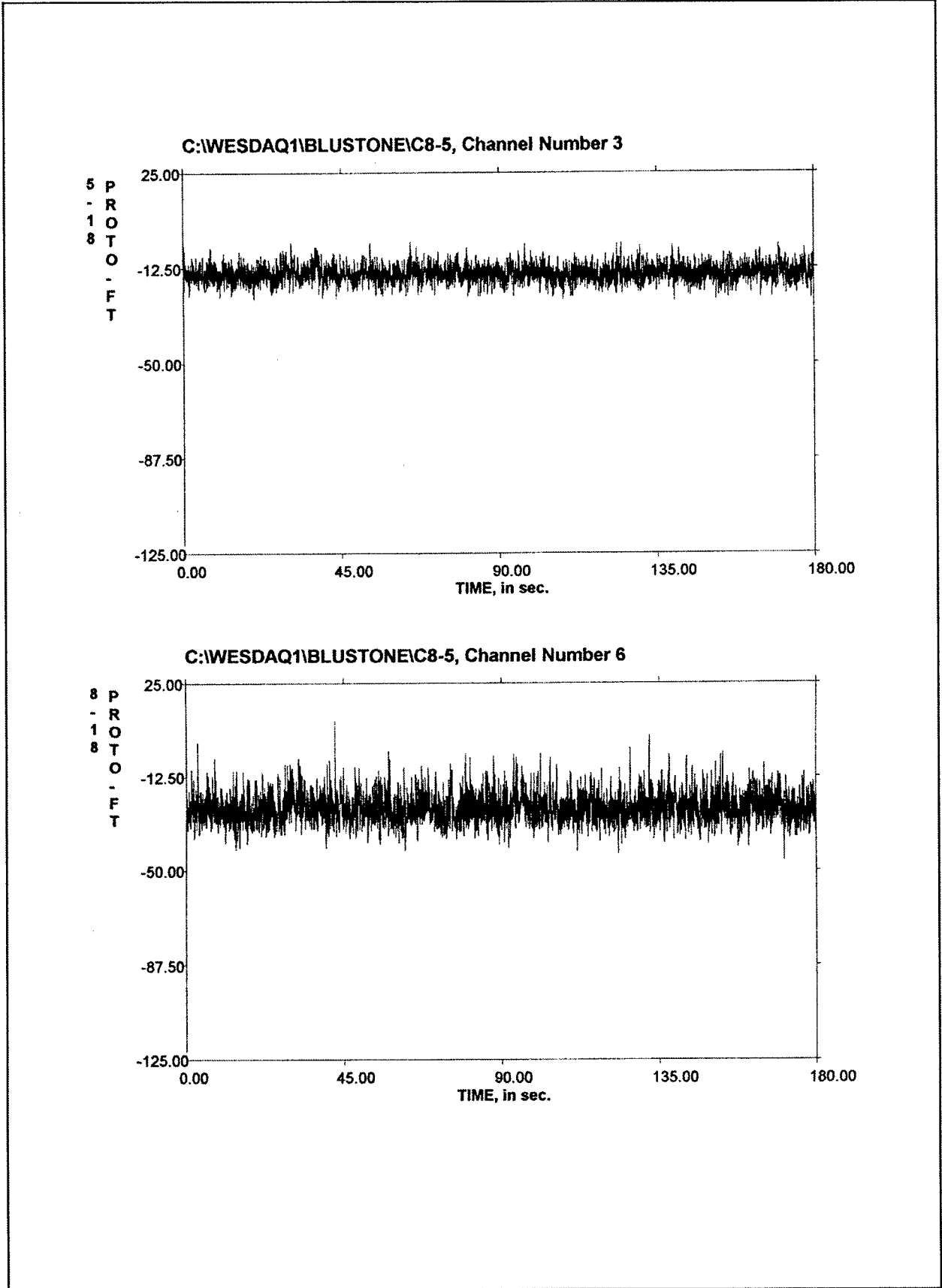

Information File Name: c:\wesdaq1\C8-6.inf
 Sample Rate: 50.000 samples/sec/channel
 Number of Seconds Recorded: 180.000 seconds
 Data Collected on 6/5/00 11:45:16 AM
 Bluestone Dam Model
 1:65 Scale
 Condition No. 8: Pool Elevation = 1531.2 Prototype Ft.
 All 6 channels filtered at 10 Hz. Low Pass
 All Calibrations and Data Recorded are in Prototype feet
 All channels are balanced and calibrated at 23.0 Ft. Prototype,
 Model Water Level at top of Stilling Weir.

ISDD Operator: Wallace Guy

CHAN NUM	MINIMUM MEASUREMENT	AVERAGE MEASUREMENT	STATISTICS			ROOT MEAN SQUARE	ENGINEERING UNI
			MAXIMUM MEASUREMENT	STANDARD DEVIATION			
1	-1.090	33.186	61.154	8.424	34.239	PROTO-FT	
2	-113.053	-89.478	-40.037	9.933	90.028	PROTO-FT	
3	-26.596	-15.052	-0.288	3.208	15.390	PROTO-FT	
4	-55.237	-19.341	18.953	10.090	21.814	PROTO-FT	
5	-89.585	-71.179	-33.035	6.220	71.450	PROTO-FT	
6	-44.063	-25.349	0.659	5.534	25.946	PROTO-FT	

CHAN NUM	GAIN	CALIBRATION INFORMATION				ENGINEERING UNITS	TYPE OF G
		BASE VOLTAGE	CALSTEP VOLTAGE	BASE ENG VALUE	CAL STEP ENG VALUE		
1	1.0	0.005	2.006	23.000	51.199	PROTO-FT	5-2
2	1.0	-0.005	1.012	23.000	50.701	PROTO-FT	5-11
3	1.0	-0.006	2.006	23.000	48.036	PROTO-FT	5-18
4	1.0	0.005	1.406	23.000	44.900	PROTO-FT	8-2
5	1.0	0.006	1.013	23.000	51.205	PROTO-FT	8-11
6	1.0	0.005	1.999	23.000	58.566	PROTO-FT	8-18

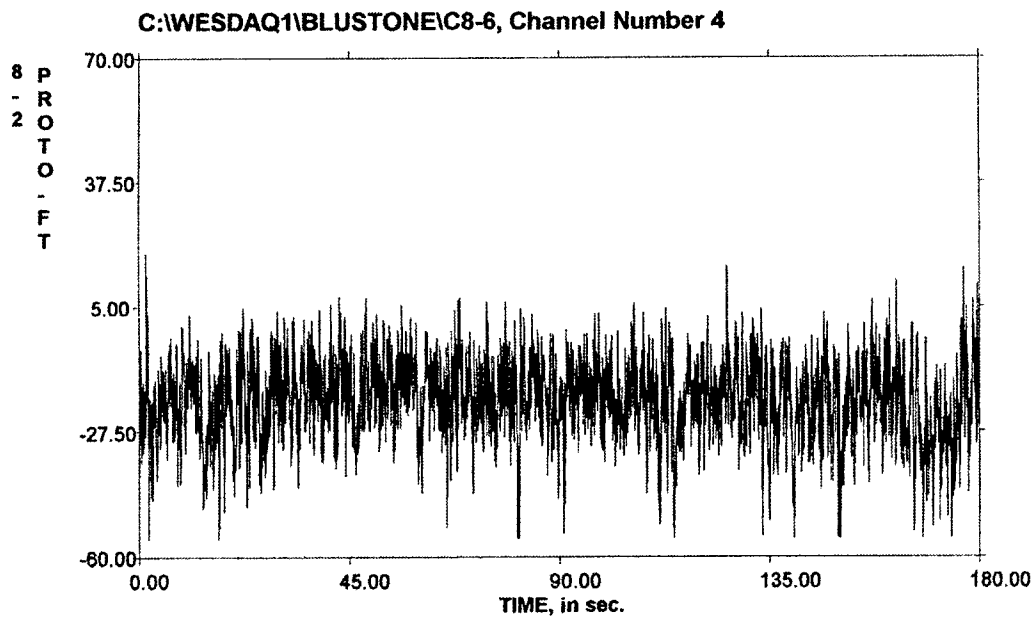
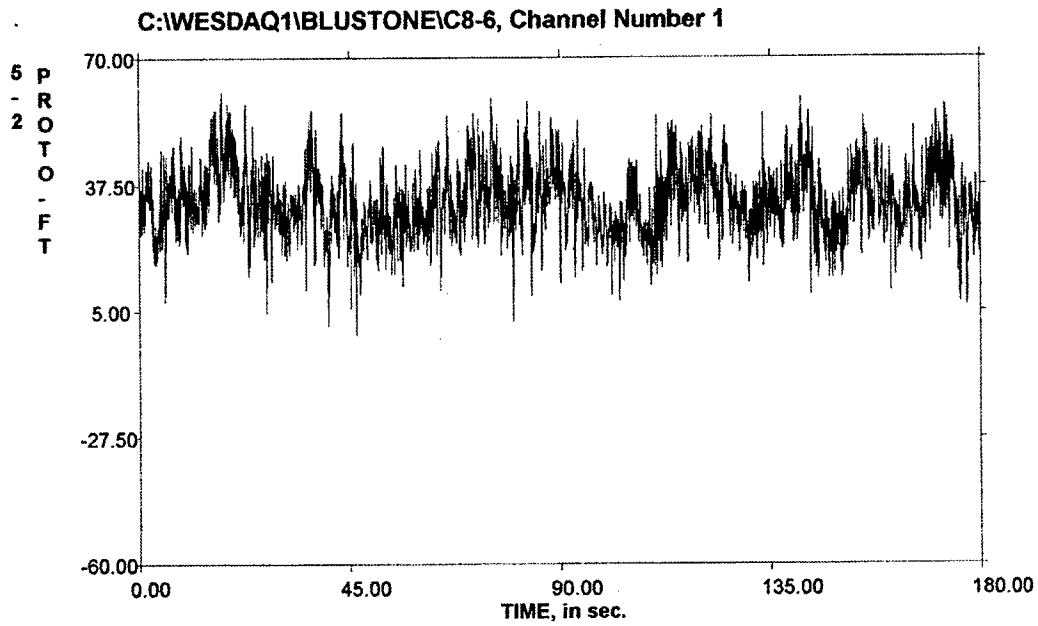

C:\WESDAQ1\BLUSTONE\C8-6, Channel Number 2

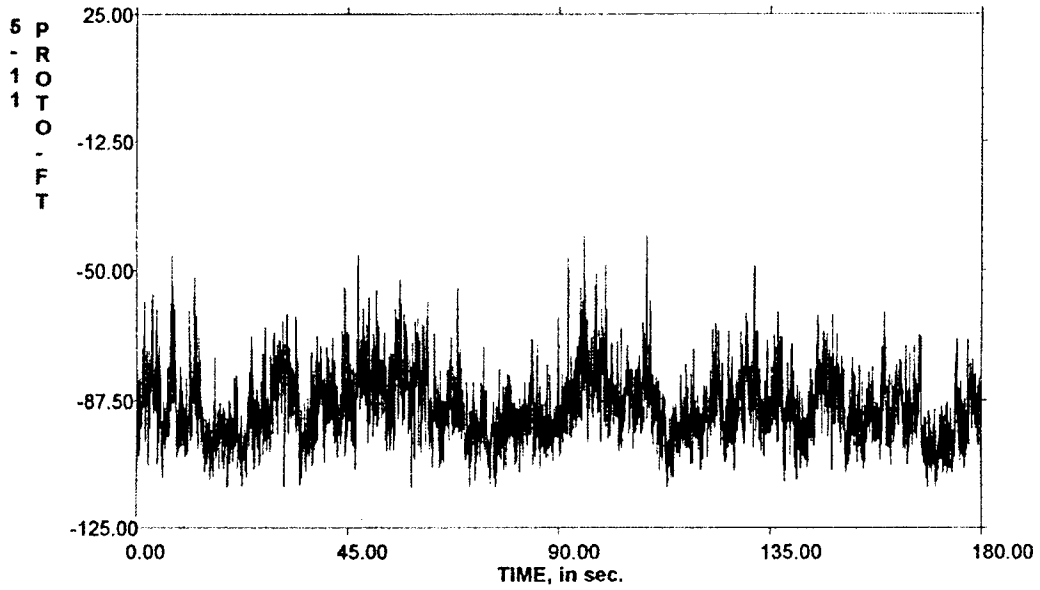

C:\WESDAQ1\BLUSTONE\C8-6, Channel Number 5

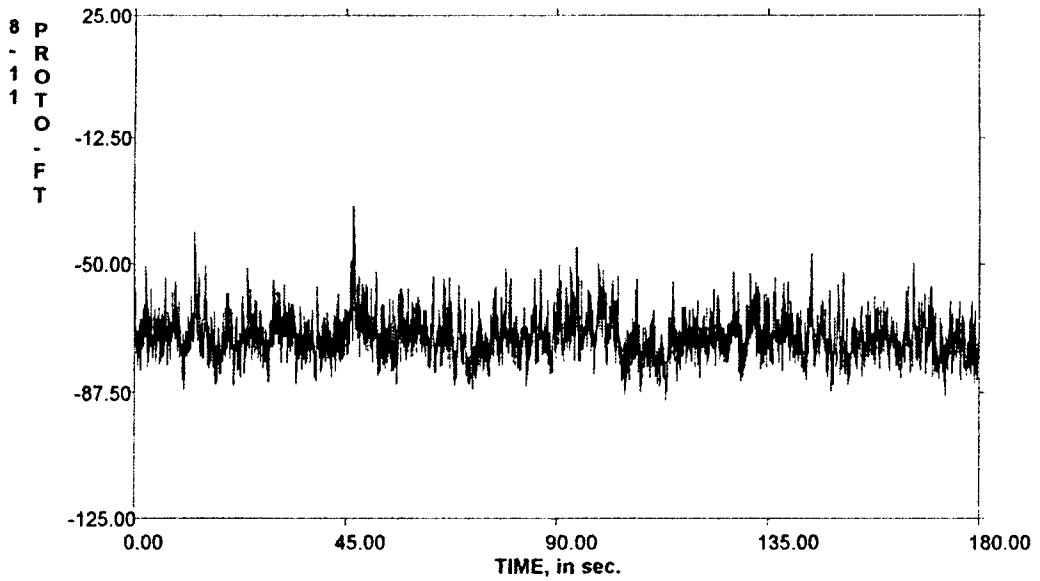

C:\WESDAQ1\BLUSTONEIC8-6, Channel Number 3

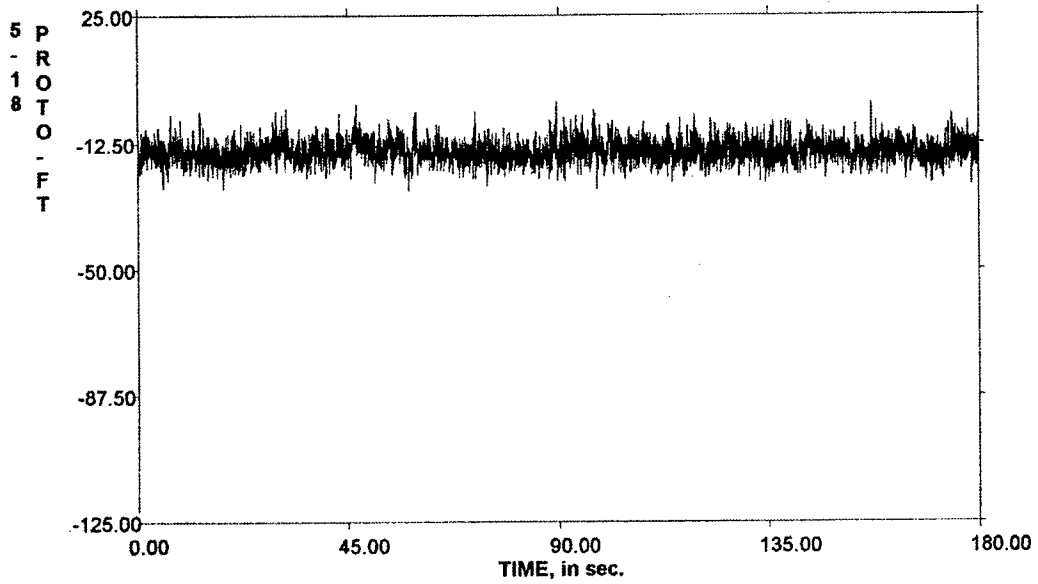

C:\WESDAQ1\BLUSTONEIC8-6, Channel Number 6

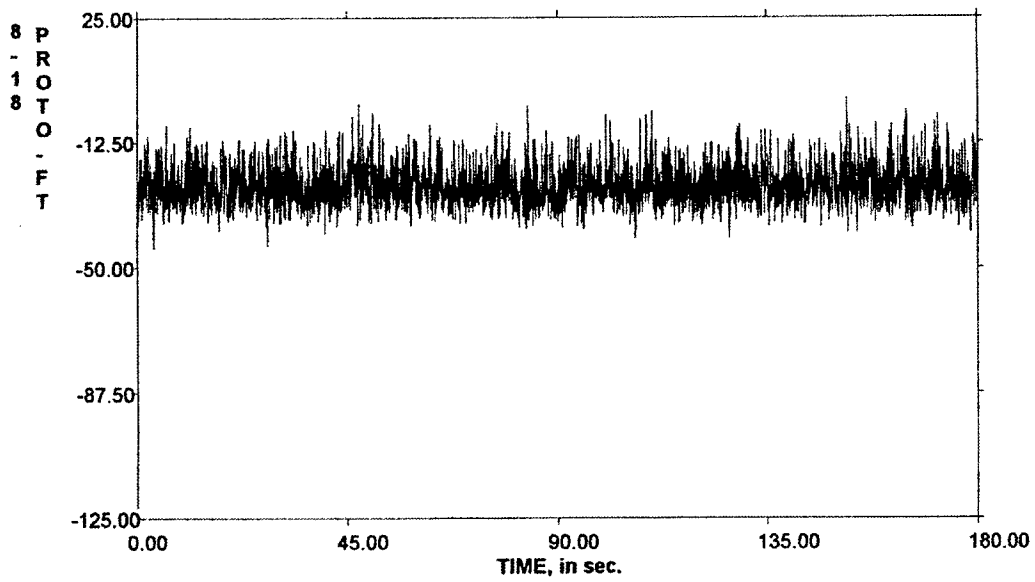

Information File Name: c:\wesdaq1\C8-7.inf
 Sample Rate: 50.000 samples/sec/channel
 Number of Seconds Recorded: 180.000 seconds
 Data Collected on 6/5/00 11:49:18 AM
 Bluestone Dam Model
 1:65 Scale
 Condition No. 8: Pool Elevation = 1531.2 Prototype Ft.
 All 6 channels filtered at 10 Hz. Low Pass
 All Calibrations and Data Recorded are in Prototype feet
 All channels are balanced and calibrated at 23.0 Ft. Prototype,
 Model Water Level at top of Stilling Weir.

ISDD Operator: Wallace Guy

STATISTICS						
CHAN	MINIMUM	AVERAGE	MAXIMUM	STANDARD	ROOT MEAN	ENGINEERING UNI
NUM	MEASUREMENT	MEASUREMENT	MEASUREMENT	DEVIATION	SQUARE	
1	2.695	32.031	62.255	8.107	33.041	PROTO-FT
2	-113.053	-88.174	-44.759	10.191	88.761	PROTO-FT
3	-25.229	-14.946	-2.050	3.147	15.274	PROTO-FT
4	-55.237	-18.094	16.663	9.552	20.461	PROTO-FT
5	-87.876	-71.014	-40.215	6.087	71.274	PROTO-FT
6	-42.060	-25.360	3.881	5.424	25.934	PROTO-FT

CALIBRATION INFORMATION							
CHAN	GAIN	BASE	CALSTEP	BASE	CAL STEP	ENGINEERING UNITS	TYPE OF G
NUM		VOLTAGE	VOLTAGE	ENG VALUE	ENG VALUE		
1	1.0	0.005	2.006	23.000	51.199	PROTO-FT	5-2
2	1.0	-0.005	1.012	23.000	50.701	PROTO-FT	5-11
3	1.0	-0.006	2.006	23.000	48.036	PROTO-FT	5-18
4	1.0	0.005	1.406	23.000	44.900	PROTO-FT	8-2
5	1.0	0.006	1.013	23.000	51.205	PROTO-FT	8-11
6	1.0	0.005	1.999	23.000	58.566	PROTO-FT	8-18

C:\WESDAQ1\BLUSTONE\C8-7, Channel Number 1

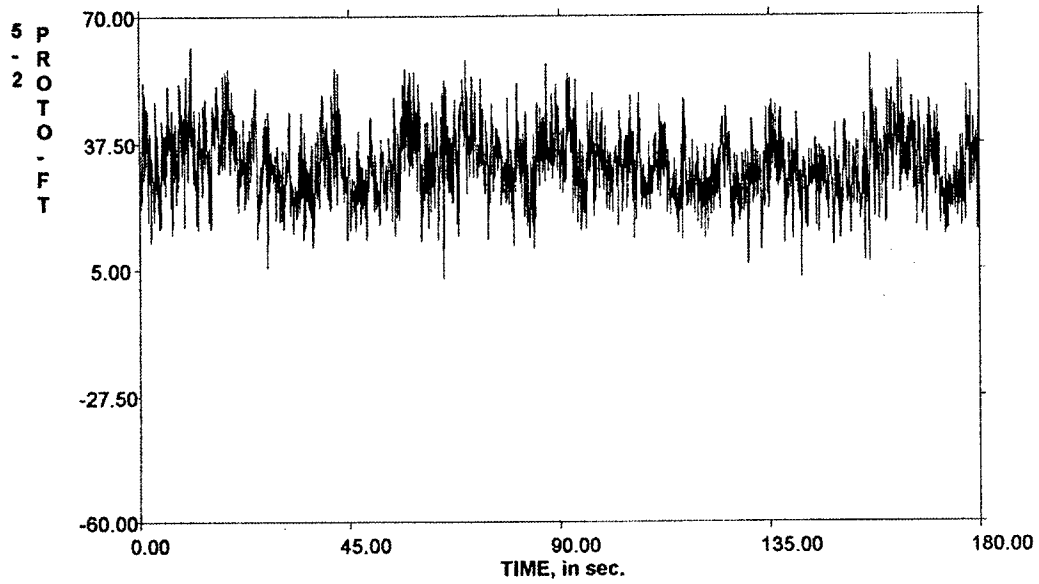

C:\WESDAQ1\BLUSTONE\C8-7, Channel Number 4

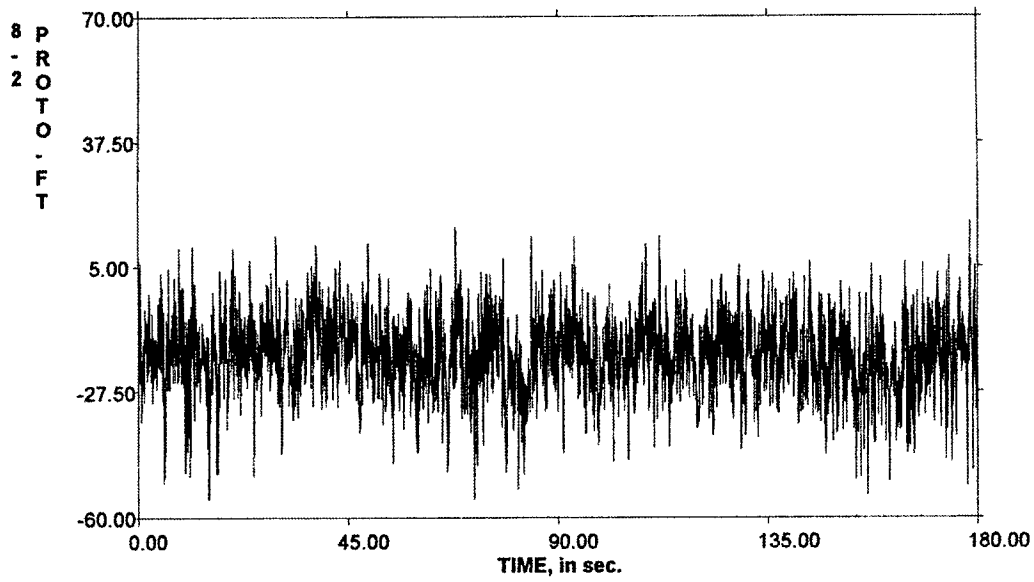

C:\WESDAQ1\BLUSTONE\IC8-7, Channel Number 2

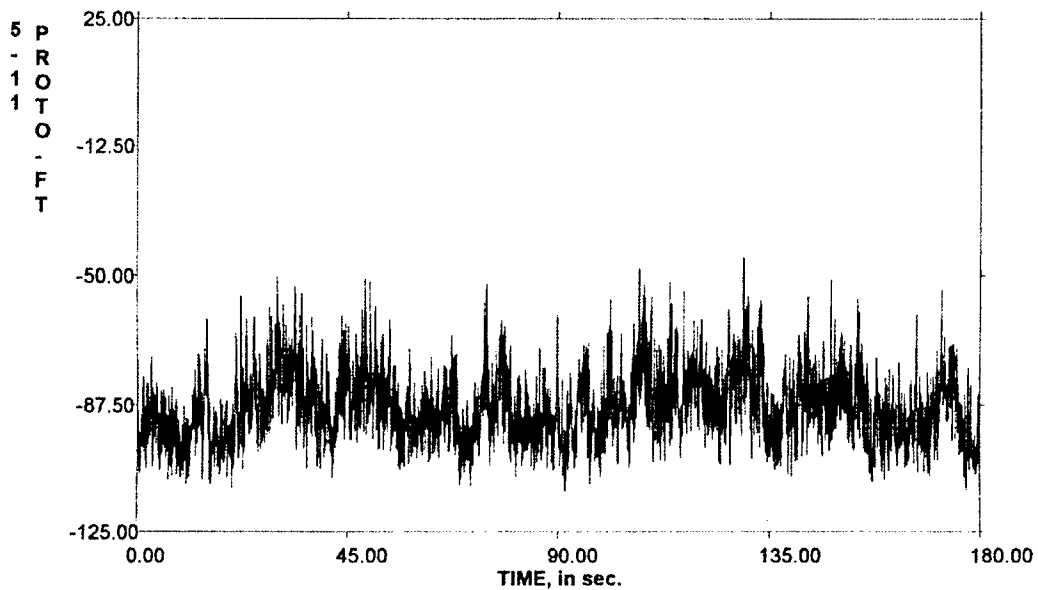

C:\WESDAQ1\BLUSTONE\IC8-7, Channel Number 5

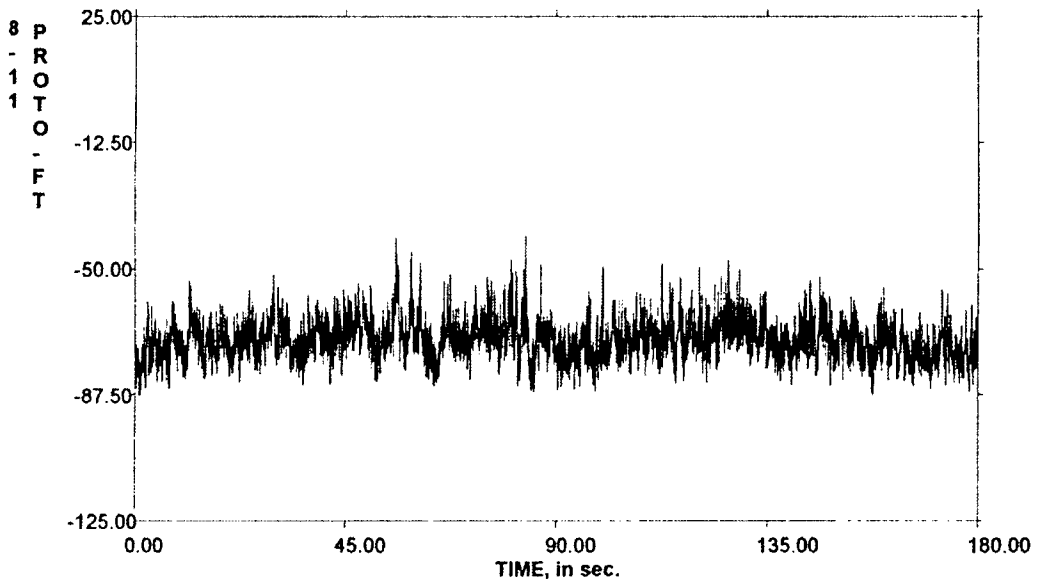

C:\WESDAQ1\BLUSTONE\C8-7, Channel Number 3

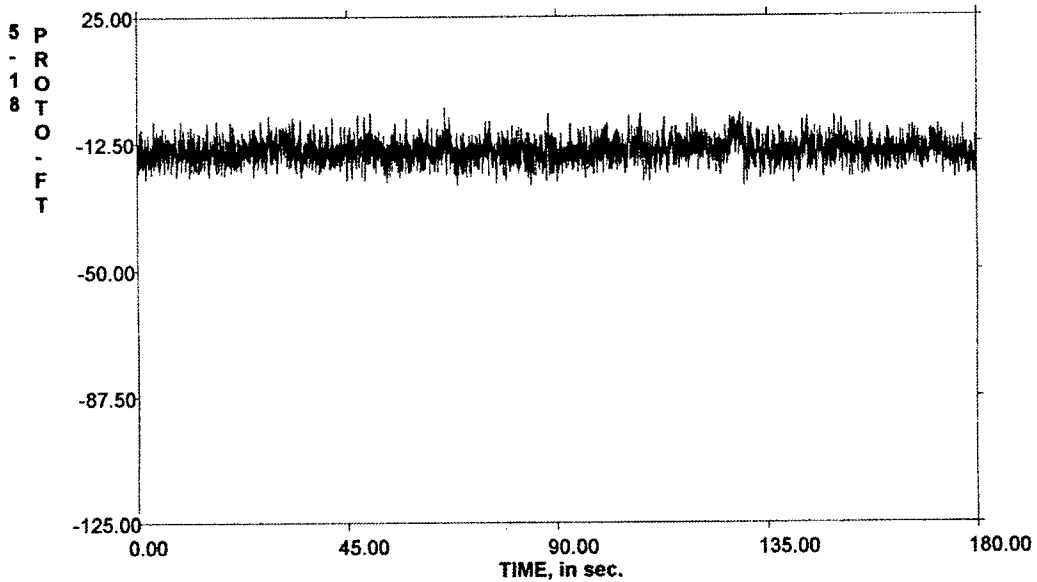

C:\WESDAQ1\BLUSTONE\C8-7, Channel Number 6

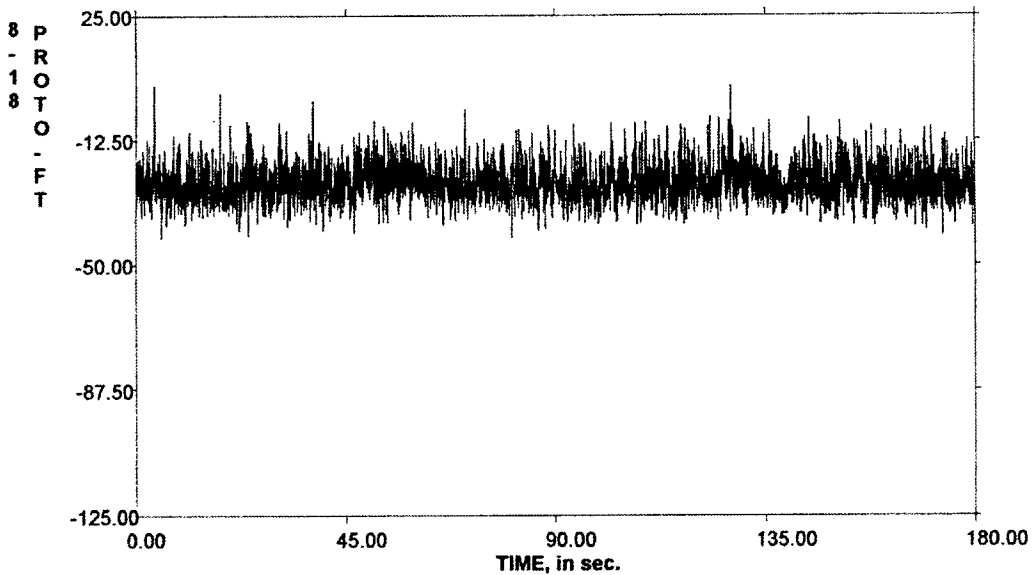

Information File Name: c:\wesdaq1\C8-1.inf
 Sample Rate: 50.000 samples/sec/channel
 Number of Seconds Recorded: 180.000 seconds
 Data Collected on 6/2/00 9:57:27 AM

Bluestone Dam Model
 1:65 Scale

Condition No. 8: Pool Elevation = 1531.2 Prototype Ft.
 All 6 channels filtered at 10 Hz. Low Pass
 All Calibrations and Data Recorded are in Prototype feet
 All channels are balanced and calibrated at 23.0 Ft. Prototype,
 Model Water Level at top of Stilling Weir.

ISDD Operator: Wallace Guy

STATISTICS						
CHAN	MINIMUM	AVERAGE	MAXIMUM	STANDARD	ROOT MEAN	ENGINEERING UNI
NUM	MEASUREMENT	MEASUREMENT	MEASUREMENT	DEVIATION	SQUARE	
1	11.447	38.423	65.412	8.367	39.323	PROTO-FT
2	-98.894	-75.446	-30.547	8.953	75.975	PROTO-FT
3	-19.393	-8.232	10.253	3.075	8.787	PROTO-FT
4	-31.086	-12.144	24.752	9.545	15.446	PROTO-FT
5	-84.380	-66.775	-38.690	5.487	67.000	PROTO-FT
6	-56.505	-34.515	-2.885	8.004	35.430	PROTO-FT

CALIBRATION INFORMATION						
CHAN	GAIN	BASE	CALSTEP	BASE	CAL STEP	ENGINEERING UNITS
NUM		VOLTAGE	VOLTAGE	ENG VALUE	ENG VALUE	
1	1.0	-0.005	2.010	23.000	51.199	PROTO-FT
2	1.0	0.008	1.044	23.000	50.701	PROTO-FT
3	1.0	0.011	2.009	23.000	48.036	PROTO-FT
4	1.0	0.011	2.040	23.000	44.900	PROTO-FT
5	1.0	0.003	1.067	23.000	51.205	PROTO-FT
6	1.0	-0.004	2.086	23.000	58.566	PROTO-FT

C:\WESDAQ1\BLUSTONE\C8-1, Channel Number 1

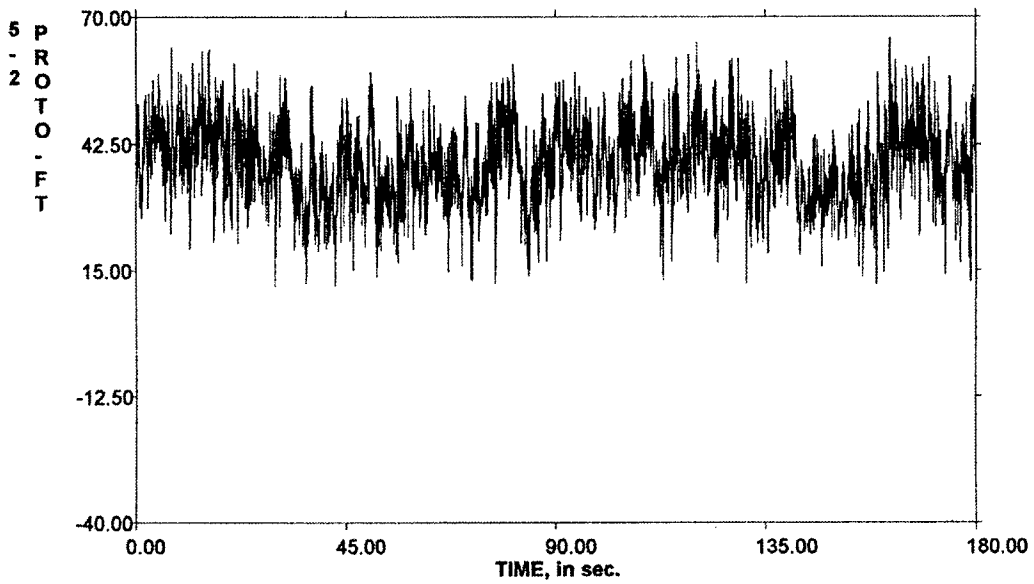

C:\WESDAQ1\BLUSTONE\C8-1, Channel Number 4

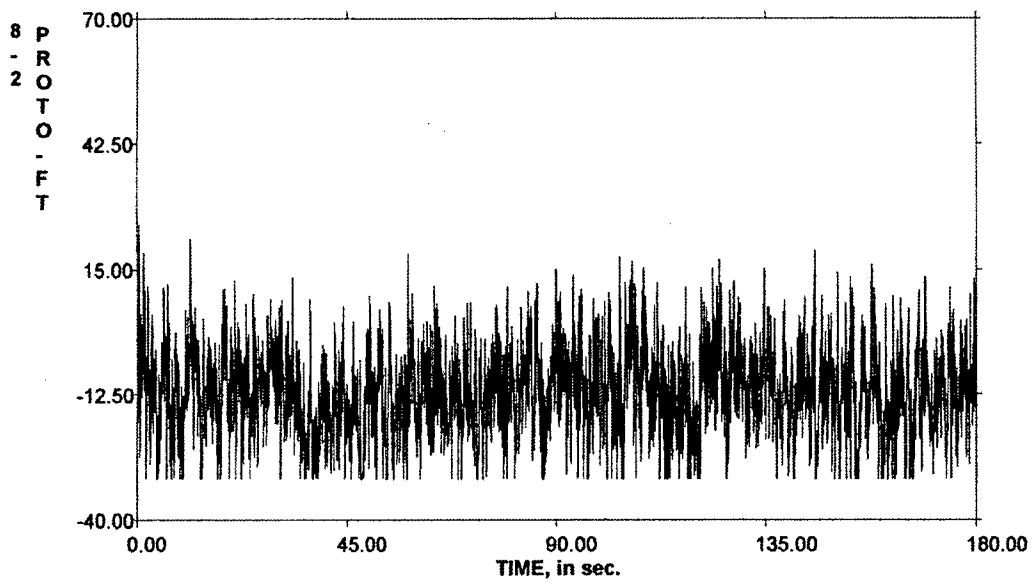

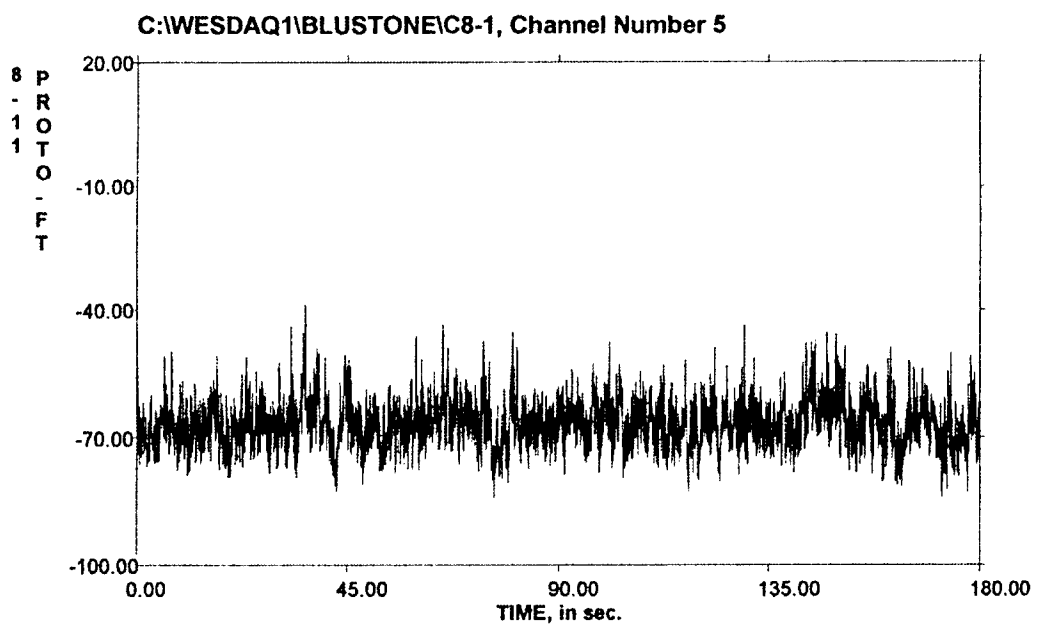
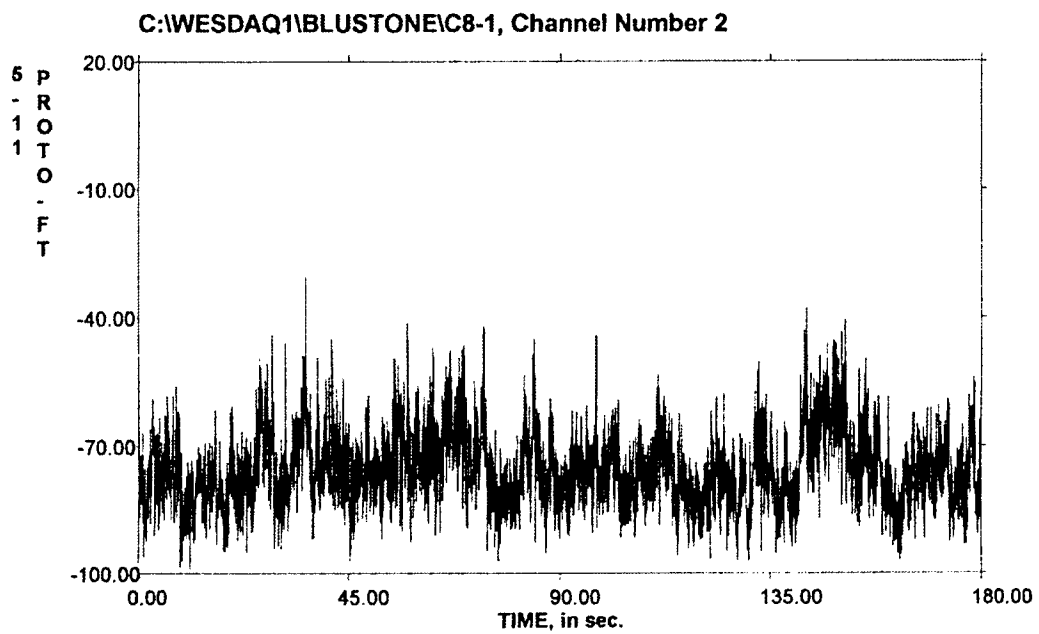

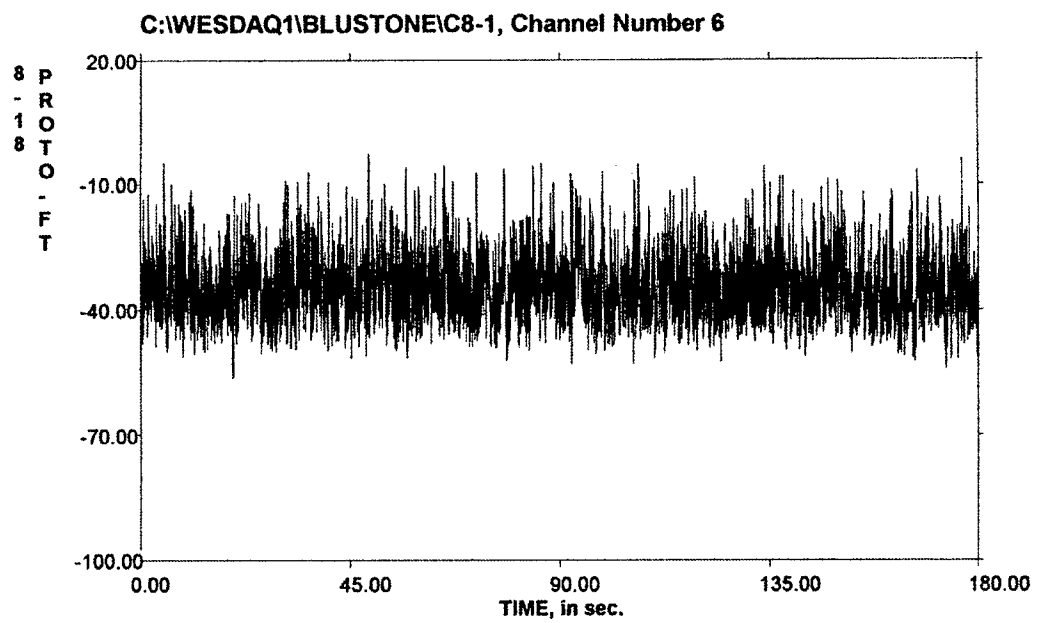
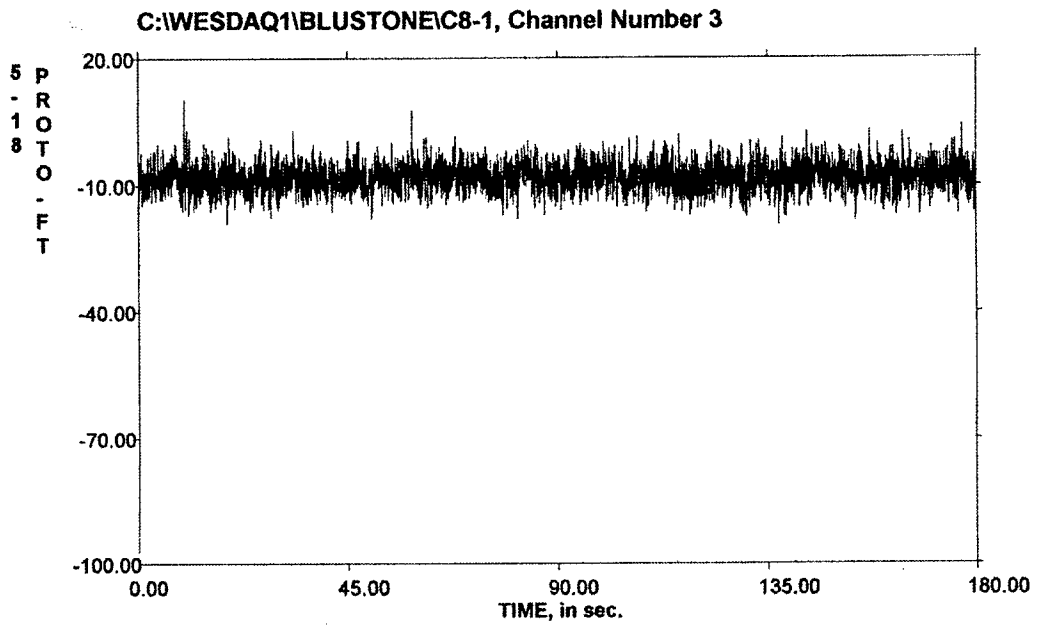

Information File Name: c:\wesdaq1\C8-2.inf
 Sample Rate: 50.000 samples/sec/channel
 Number of Seconds Recorded: 180.000 seconds
 Data Collected on 6/2/00 10:06:52 AM

Bluestone Dam Model
 1:65 Scale

Condition No. 8: Pool Elevation = 1531.2 Prototype Ft.
 All 6 channels filtered at 10 Hz. Low Pass
 All Calibrations and Data Recorded are in Prototype feet
 All channels are balanced and calibrated at 23.0 Ft. Prototype,
 Model Water Level at top of Stilling Weir.

ISDD Operator: Wallace Guy

STATISTICS						
CHAN	MINIMUM	AVERAGE	MAXIMUM	STANDARD	ROOT MEAN	ENGINEERING UNI
NUM	MEASUREMENT	MEASUREMENT	MEASUREMENT	DEVIATION	SQUARE	
1	1.570	39.457	67.497	8.522	40.367	PROTO-FT
2	-99.024	-76.915	-37.270	8.593	77.393	PROTO-FT
3	-23.095	-9.066	6.307	3.110	9.585	PROTO-FT
4	-31.086	-12.824	22.038	9.566	15.999	PROTO-FT
5	-84.121	-67.079	-32.218	5.775	67.327	PROTO-FT
6	-54.179	-34.843	0.936	7.647	35.672	PROTO-FT

CALIBRATION INFORMATION							
CHAN	GAIN	BASE	CALSTEP	BASE	CAL STEP	ENGINEERING UNITS	TYPE OF G
NUM		VOLTAGE	VOLTAGE	ENG VALUE	ENG VALUE		
1	1.0	-0.005	2.010	23.000	51.199	PROTO-FT	5-2
2	1.0	0.008	1.044	23.000	50.701	PROTO-FT	5-11
3	1.0	0.011	2.009	23.000	48.036	PROTO-FT	5-18
4	1.0	0.011	2.040	23.000	44.900	PROTO-FT	8-2
5	1.0	0.003	1.067	23.000	51.205	PROTO-FT	8-11
6	1.0	-0.004	2.086	23.000	58.566	PROTO-FT	8-18

C:\WESDAQ1\BLUSTONE\IC8-2, Channel Number 1

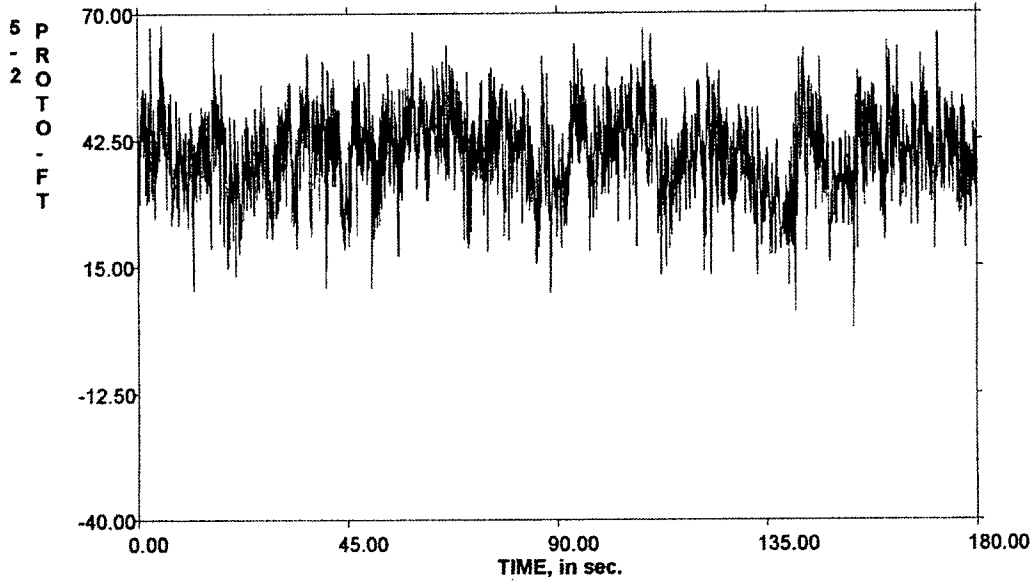

C:\WESDAQ1\BLUSTONE\IC8-2, Channel Number 4

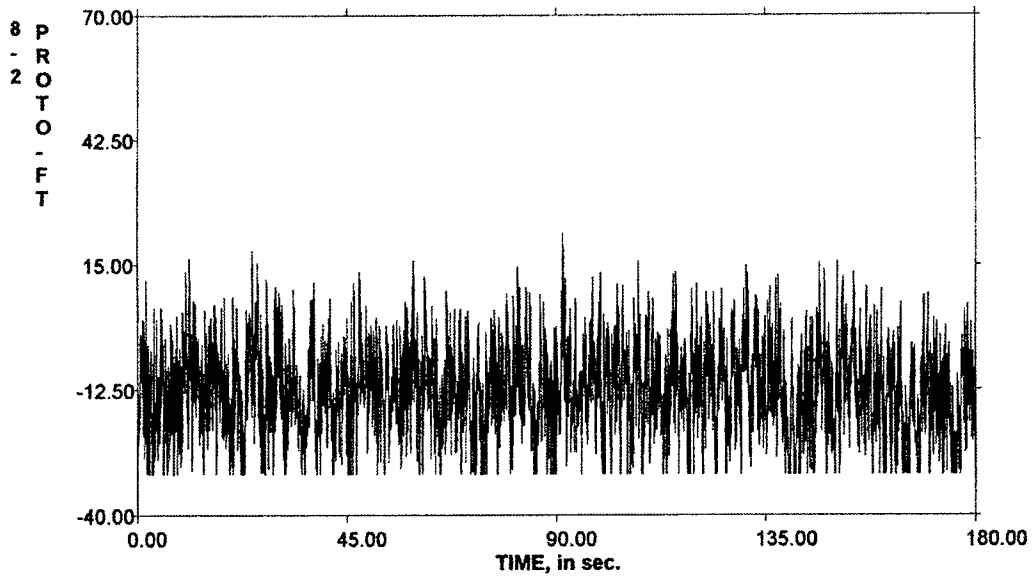

C:\WESDAQ1\BLUSTONE\C8-2, Channel Number 2

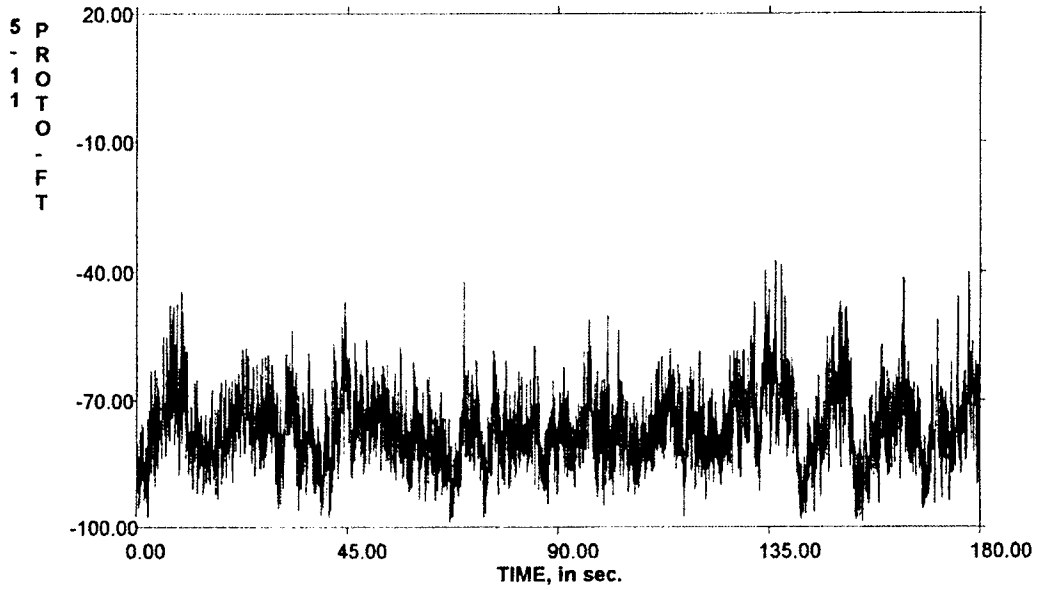

C:\WESDAQ1\BLUSTONE\C8-2, Channel Number 5

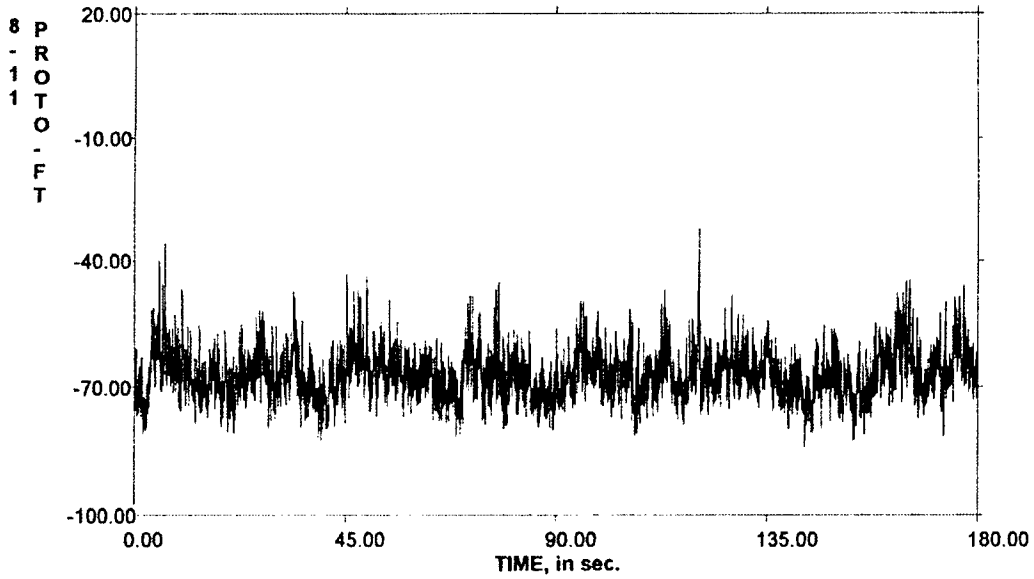

C:\WESDAQ1\BLUSTONE\C8-2, Channel Number 3

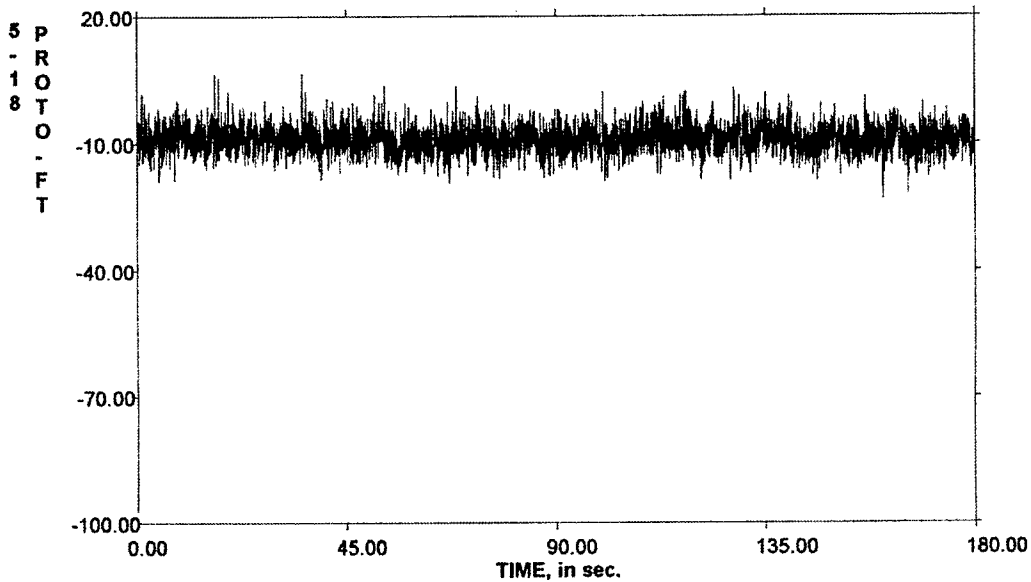

C:\WESDAQ1\BLUSTONE\C8-2, Channel Number 6

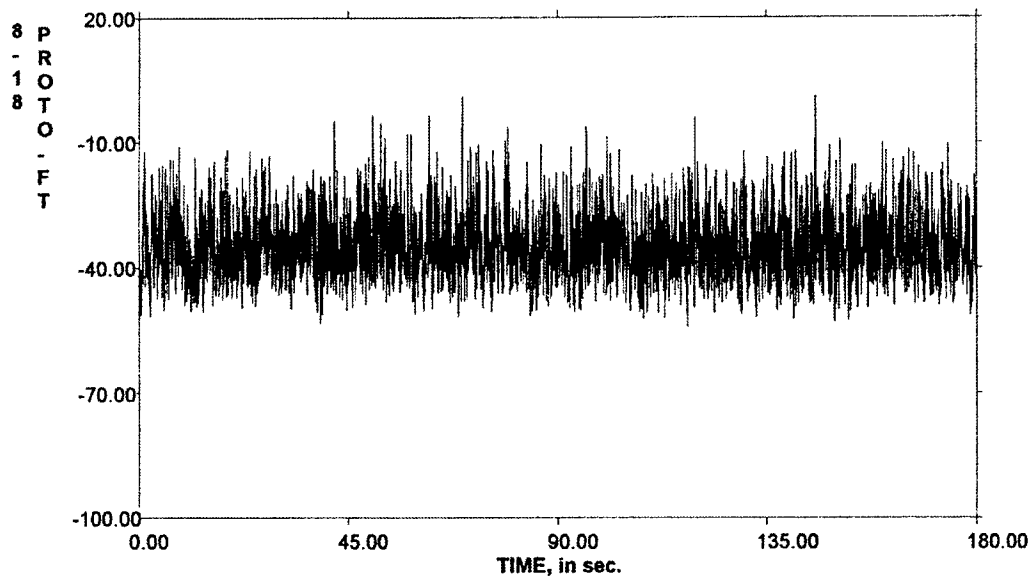

Information File Name: c:\wesdaq1\C8-3.inf
 Sample Rate: 50.000 samples/sec/channel
 Number of Seconds Recorded: 180.000 seconds
 Data Collected on 6/2/00 10:15:36 AM

Bluestone Dam Model
 1:65 Scale

Condition No. 8: Pool Elevation = 1531.2 Prototype Ft.

All 6 channels filtered at 10 Hz. Low Pass

All Calibrations and Data Recorded are in Prototype feet

All channels are balanced and calibrated at 23.0 Ft. Prototype,
 Model Water Level at top of Stilling Weir.

ISDD Operator: Wallace Guy

STATISTICS

CHAN NUM	MINIMUM MEASUREMENT	AVERAGE MEASUREMENT	MAXIMUM MEASUREMENT	STANDARD DEVIATION	ROOT MEAN SQUARE	ENGINEERING UNI PROTO-FT
1	5.330	37.402	64.933	7.889	38.225	PROTO-FT
2	-100.722	-74.652	-36.161	8.693	75.156	PROTO-FT
3	-20.984	-9.191	2.605	3.112	9.703	PROTO-FT
4	-31.086	-12.030	19.535	9.142	15.109	PROTO-FT
5	-82.180	-66.280	-35.131	5.238	66.487	PROTO-FT
6	-54.885	-34.656	4.342	7.892	35.543	PROTO-FT

CALIBRATION INFORMATION

CHAN NUM	GAIN	BASE VOLTAGE	CALSTEP VOLTAGE	BASE ENG VALUE	CAL STEP ENG VALUE	ENGINEERING UNITS PROTO-FT	TYPE OF G
1	1.0	-0.005	2.010	23.000	51.199	PROTO-FT	5-2
2	1.0	0.008	1.044	23.000	50.701	PROTO-FT	5-11
3	1.0	0.011	2.009	23.000	48.036	PROTO-FT	5-18
4	1.0	0.011	2.040	23.000	44.900	PROTO-FT	8-2
5	1.0	0.003	1.067	23.000	51.205	PROTO-FT	8-11
6	1.0	-0.004	2.086	23.000	58.566	PROTO-FT	8-18

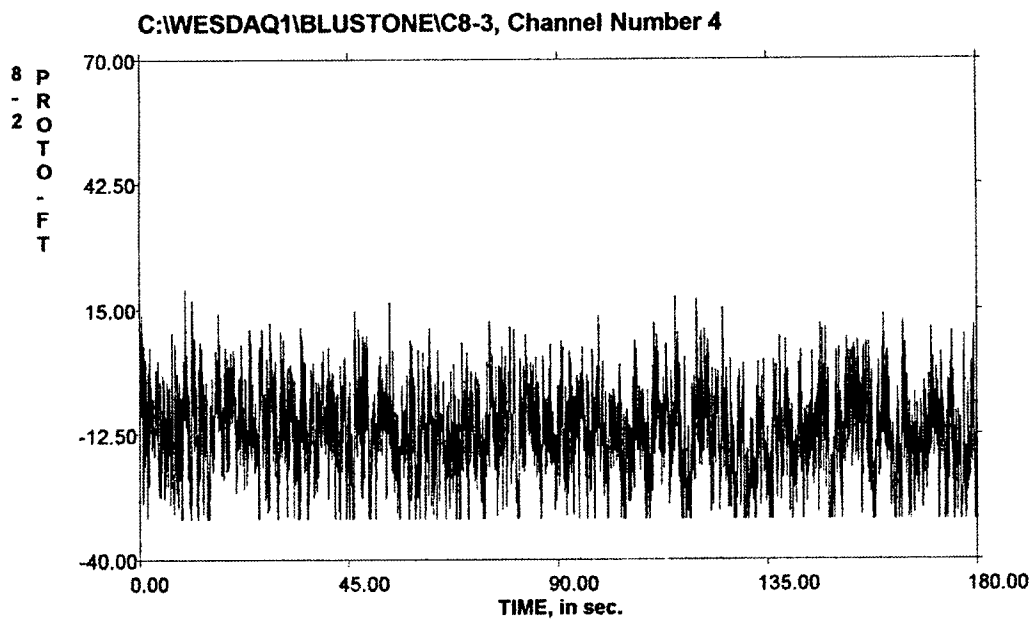
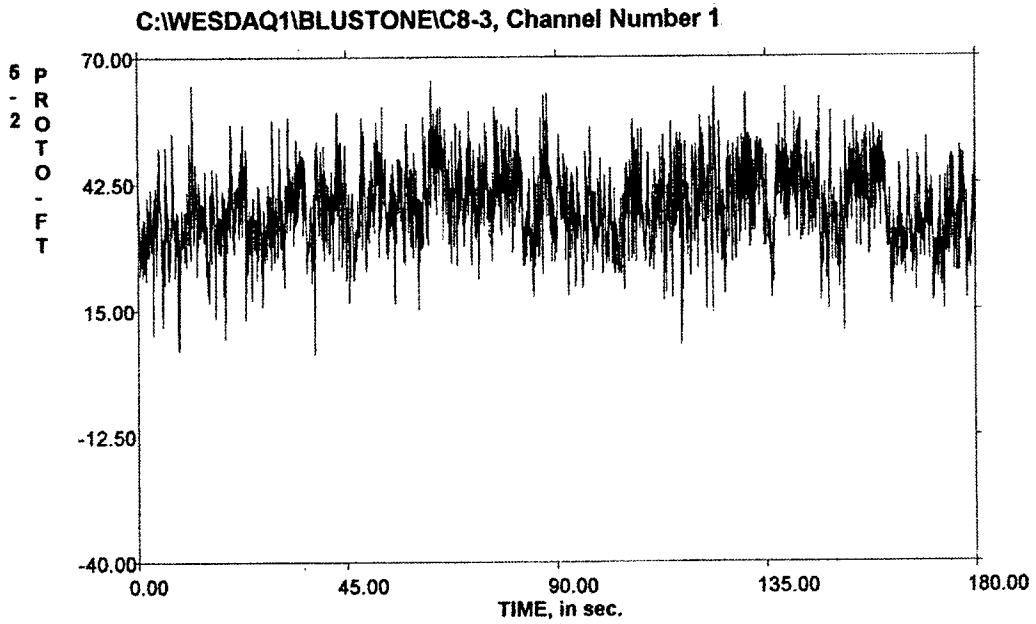

C:\WESDAQ1\BLUSTONE\C8-3, Channel Number 2

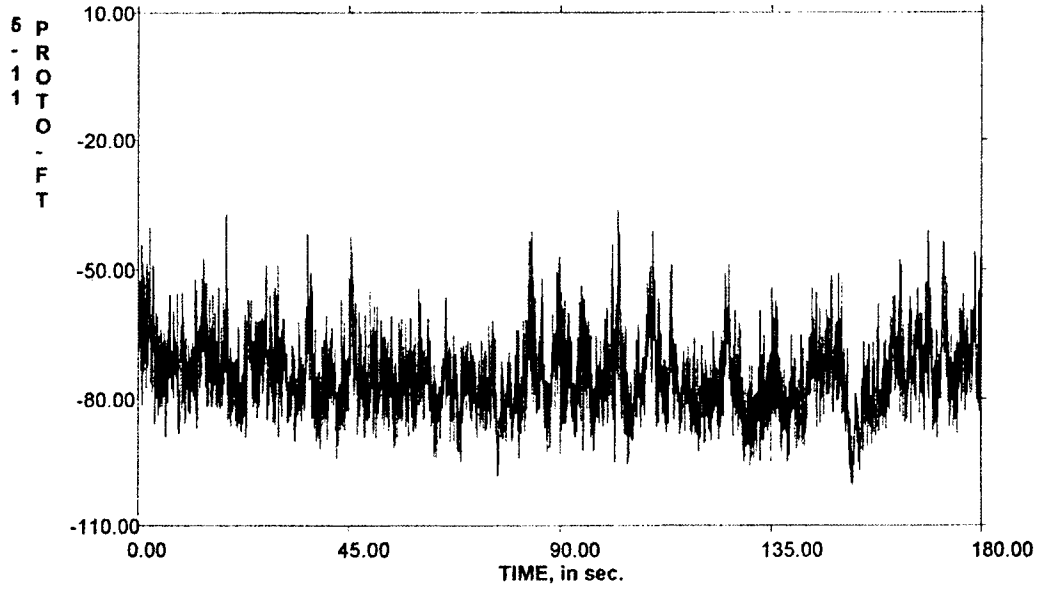

C:\WESDAQ1\BLUSTONE\C8-3, Channel Number 5

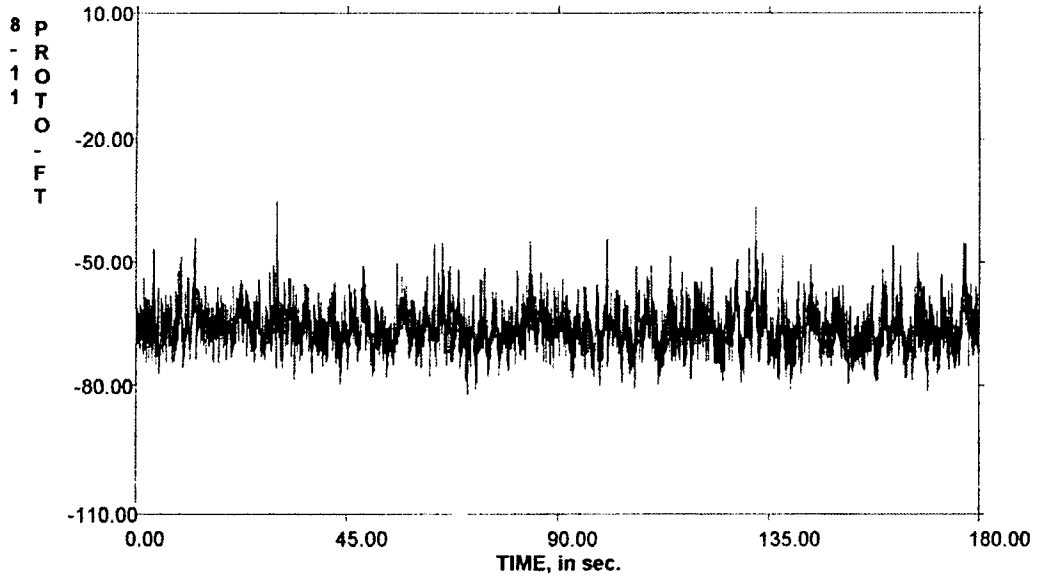

C:\WESDAQ1\BLUSTONE\C8-3, Channel Number 3

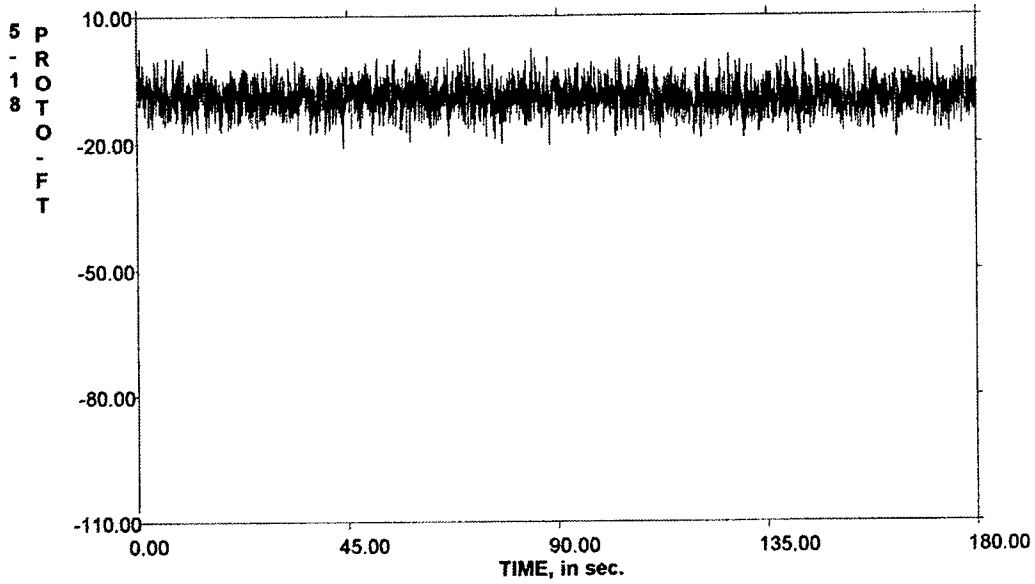

C:\WESDAQ1\BLUSTONE\C8-3, Channel Number 6

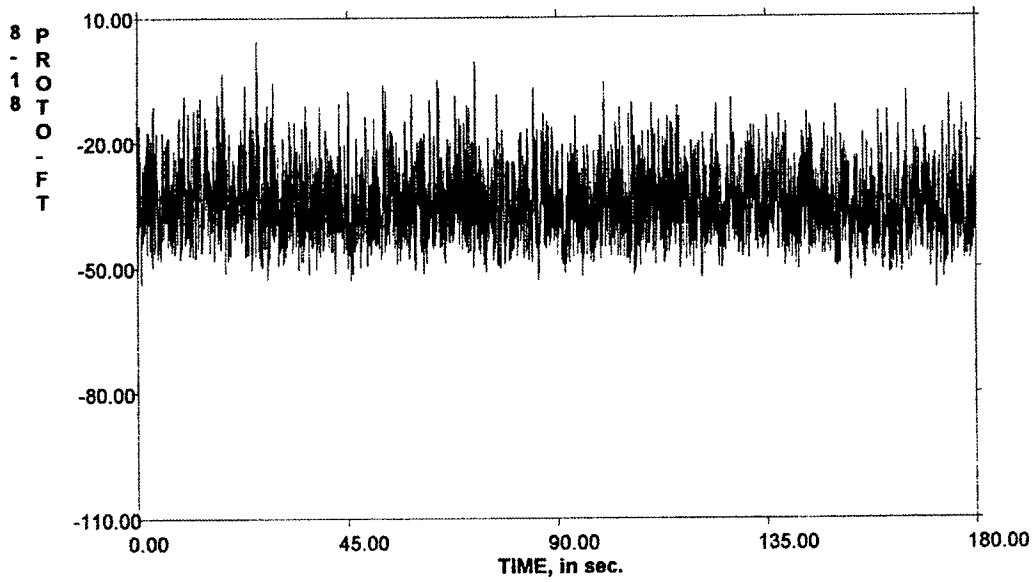

Information File Name: c:\wesdaq1\C9-1.inf
 Sample Rate: 50.000 samples/sec/channel
 Number of Seconds Recorded: 180.000 seconds
 Data Collected on 6/1/00 2:17:32 PM
 Bluestone Dam Model
 1:65 Scale
 Condition No. 9 Pool Elevation = 1538.9Ft. Prototype
 All 6 channels filtered at 10 Hz. Low Pass
 All calibrations and Data Recorded are in Prototype feet
 All channels are balanced and calibrated at 23.0 Ft. Prototype,
 Model Water Level at top of Stilling Weir.

ISDD Operator: Guy / Ables

STATISTICS						
CHAN	MINIMUM	AVERAGE	MAXIMUM	STANDARD	ROOT MEAN	ENGINEERING UNI
NUM	MEASUREMENT	MEASUREMENT	MEASUREMENT	DEVIATION	SQUARE	
1	-48.153	36.458	69.232	10.065	37.822	PROTO-FT
2	-18.832	-9.540	-2.051	2.082	9.764	PROTO-FT
3	-28.450	-14.498	-2.005	3.148	14.836	PROTO-FT
4	-97.655	34.507	72.039	11.360	36.329	PROTO-FT
5	-20.343	-12.738	-3.633	2.079	12.907	PROTO-FT
6	-26.493	-12.034	1.270	3.573	12.553	PROTO-FT

CALIBRATION INFORMATION							
CHAN	GAIN	BASE	CALSTEP	BASE	CAL STEP	ENGINEERING UNITS	TYPE OF G
NUM		VOLTAGE	VOLTAGE	ENG VALUE	ENG VALUE		
1	1.0	-0.004	1.976	23.000	51.199	PROTO-FT	5-2
2	1.0	-0.004	1.201	23.000	50.701	PROTO-FT	5-11
3	1.0	-0.004	2.060	23.000	48.036	PROTO-FT	5-18
4	1.0	0.008	0.917	23.000	44.900	PROTO-FT	8-2
5	1.0	-0.001	1.058	23.000	51.205	PROTO-FT	8-11
6	1.0	-0.003	1.051	23.000	58.566	PROTO-FT	8-18

C:\WESDAQ1\BLUSTONE\C9-1, Channel Number 1

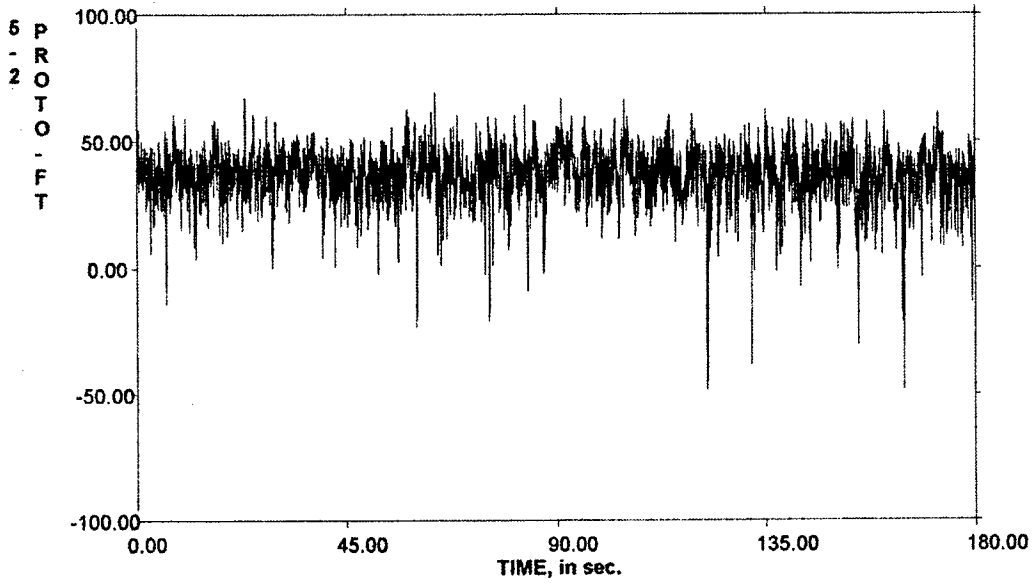

C:\WESDAQ1\BLUSTONE\C9-1, Channel Number 4

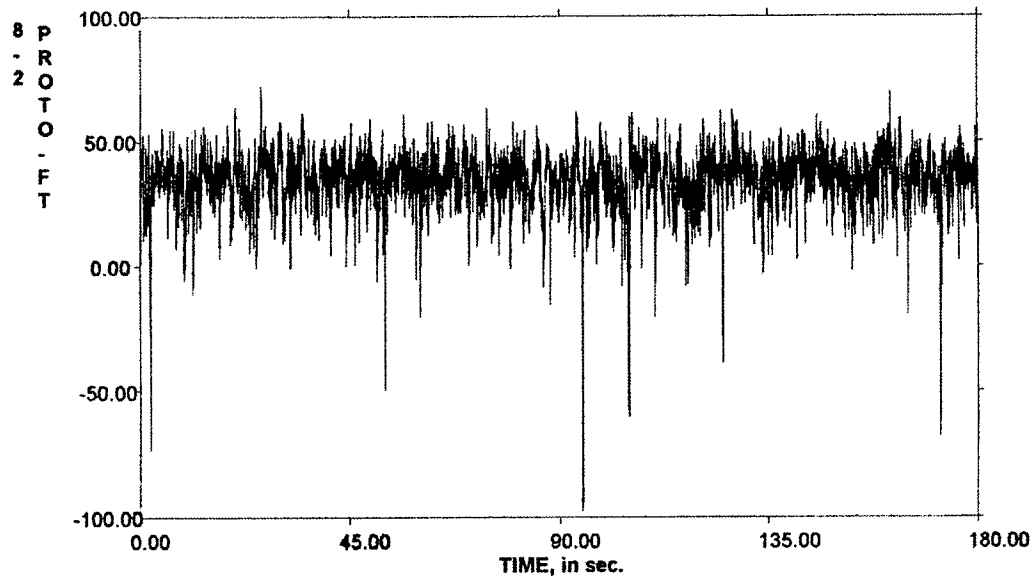

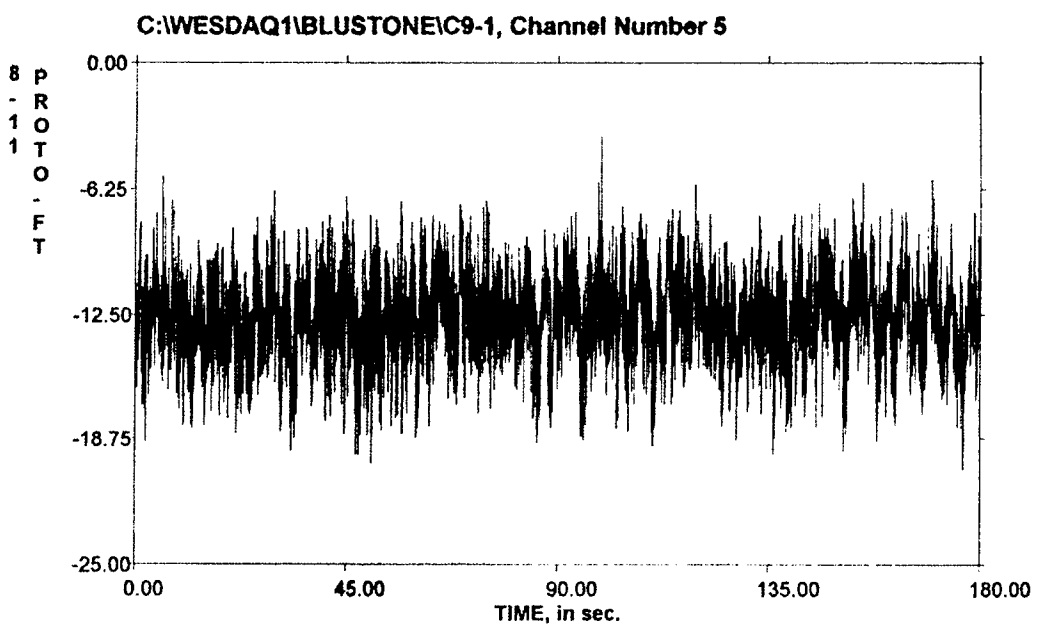
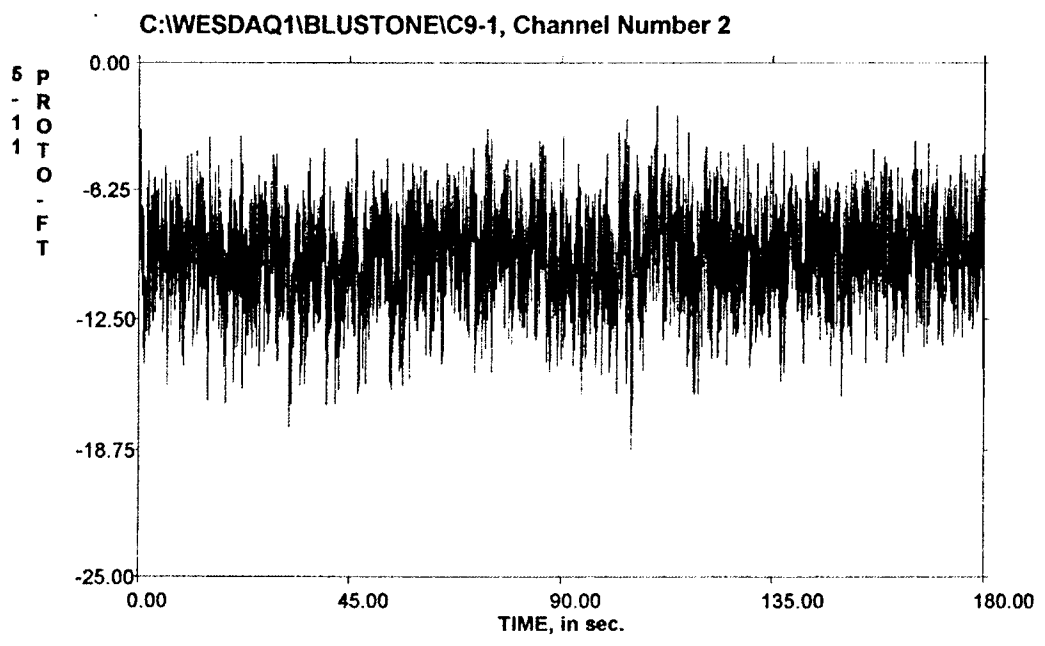

C:\WESDAQ1\BLUSTONE\C9-1, Channel Number 3

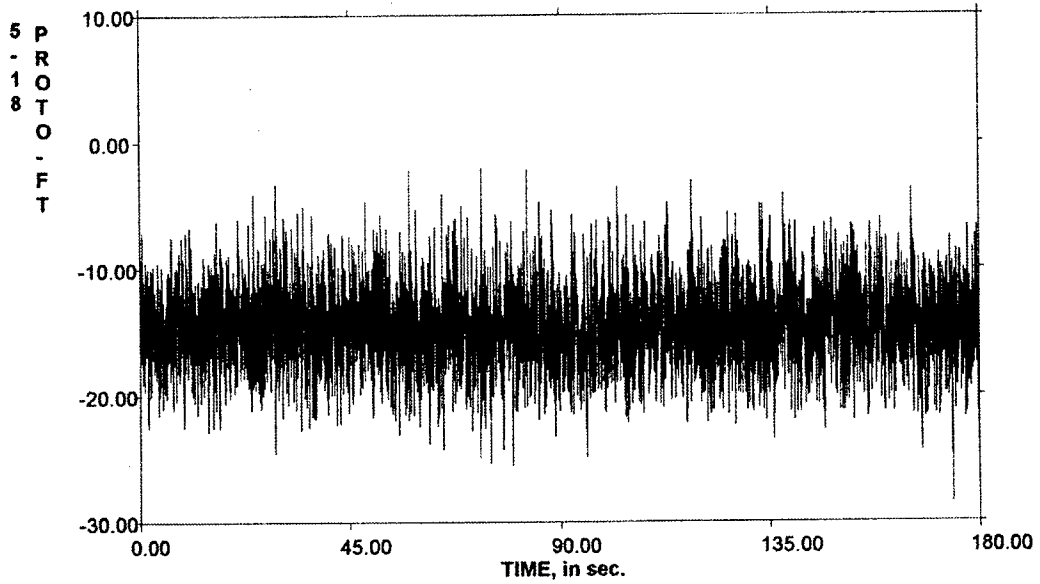

C:\WESDAQ1\BLUSTONE\C9-1, Channel Number 6

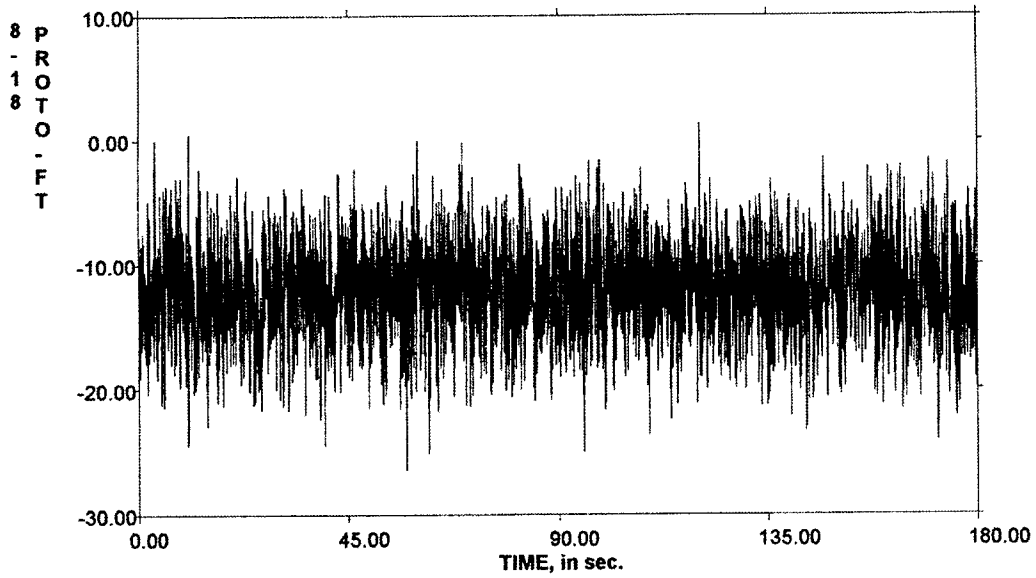

Information File Name: c:\wesdaq1\C9-2.inf
 Sample Rate: 50.000 samples/sec/channel
 Number of Seconds Recorded: 180.000 seconds
 Data Collected on 6/1/00 2:29:55 PM

Bluestone Dam Model
 1:65 Scale

Condition No. 9 Pool Elevation = 1538.9Ft. Prototype
 All 6 channels filtered at 10 Hz. Low Pass
 All calibrations and Data Recorded are in Prototype feet
 All channels are balanced and calibrated at 23.0 Ft. Prototype,
 Model Water Level at top of Stilling Weir.

ISDD Operator: Guy / Ables

CHAN NUM	STATISTICS					ROOT MEAN SQUARE	ENGINEERING UNI PROTO-FT
	MINIMUM MEASUREMENT	AVERAGE MEASUREMENT	MAXIMUM MEASUREMENT	STANDARD DEVIATION			
1	-48.153	37.251	71.353	10.180		38.617	PROTO-FT
2	-17.036	-9.653	-1.995	2.099		9.879	PROTO-FT
3	-26.496	-14.501	3.148	3.144		14.837	PROTO-FT
4	-97.655	34.326	64.569	11.134		36.087	PROTO-FT
5	-21.059	-12.614	-3.242	2.122		12.791	PROTO-FT
6	-25.175	-12.026	0.364	3.690		12.580	PROTO-FT

CHAN NUM	GAIN	CALIBRATION INFORMATION				ENGINEERING UNITS	TYPE OF G
		BASE VOLTAGE	CALSTEP VOLTAGE	BASE ENG VALUE	CAL STEP ENG VALUE		
1	1.0	-0.004	1.976	23.000	51.199	PROTO-FT	5-2
2	1.0	-0.004	1.201	23.000	50.701	PROTO-FT	5-11
3	1.0	-0.004	2.060	23.000	48.036	PROTO-FT	5-18
4	1.0	0.008	0.917	23.000	44.900	PROTO-FT	8-2
5	1.0	-0.001	1.058	23.000	51.205	PROTO-FT	8-11
6	1.0	-0.003	1.051	23.000	58.566	PROTO-FT	8-18

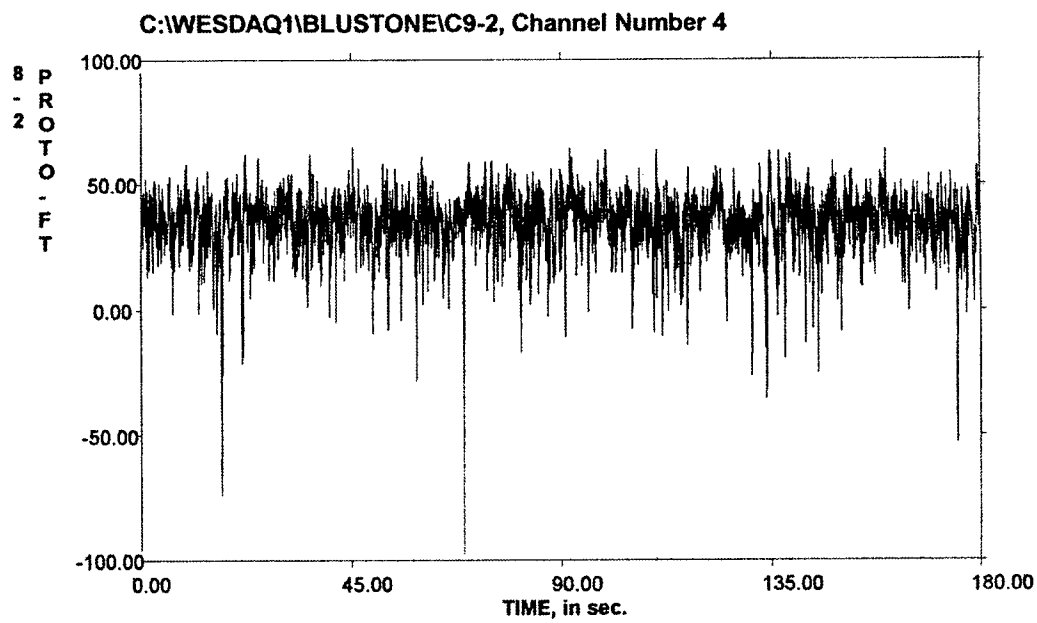
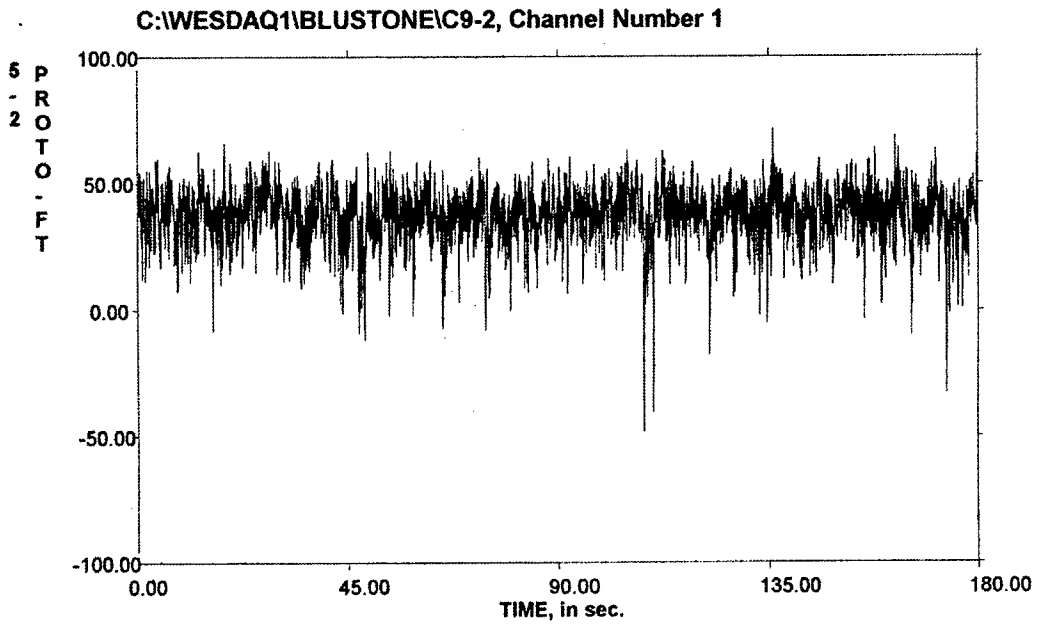

C:\WESDAQ1\BLUSTONE\C9-2, Channel Number 2

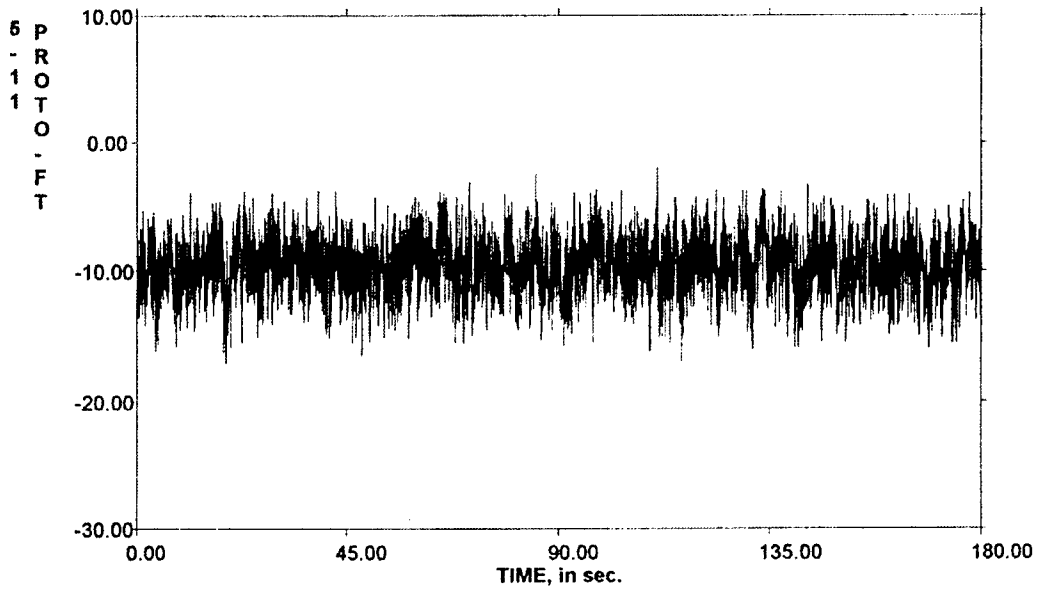

C:\WESDAQ1\BLUSTONE\C9-2, Channel Number 5

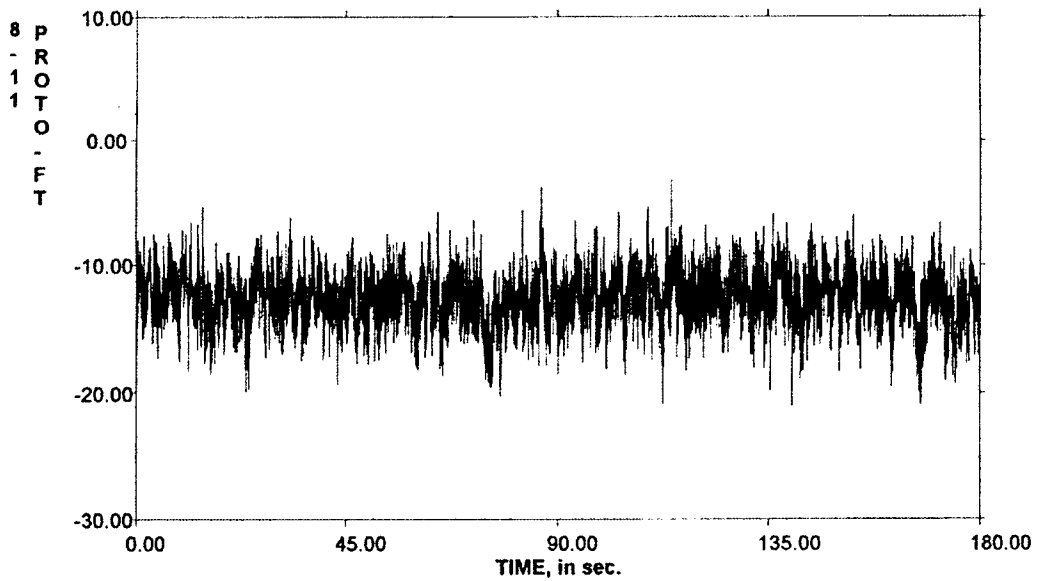

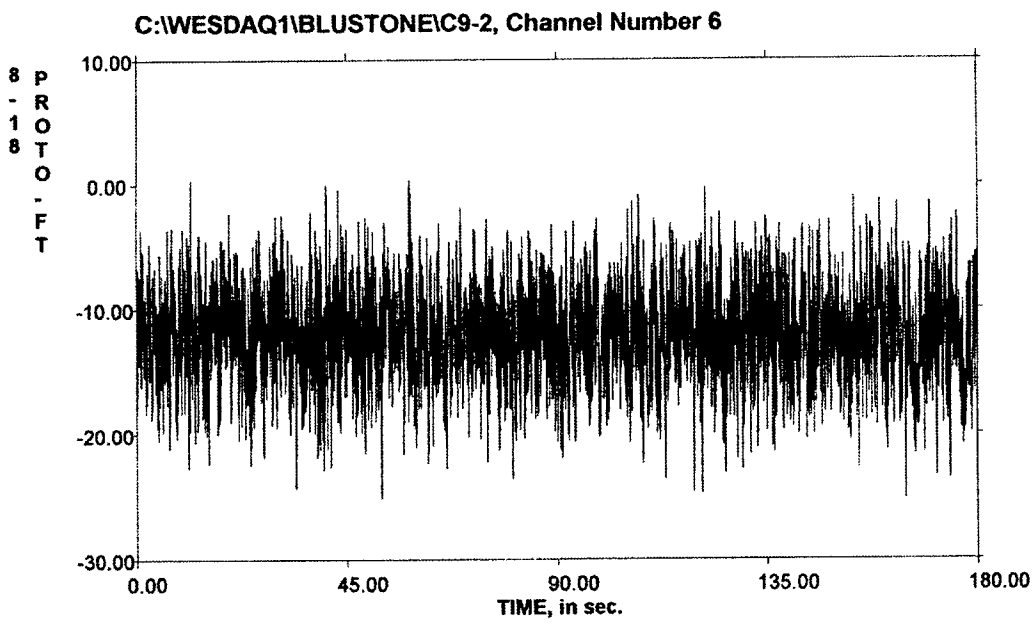
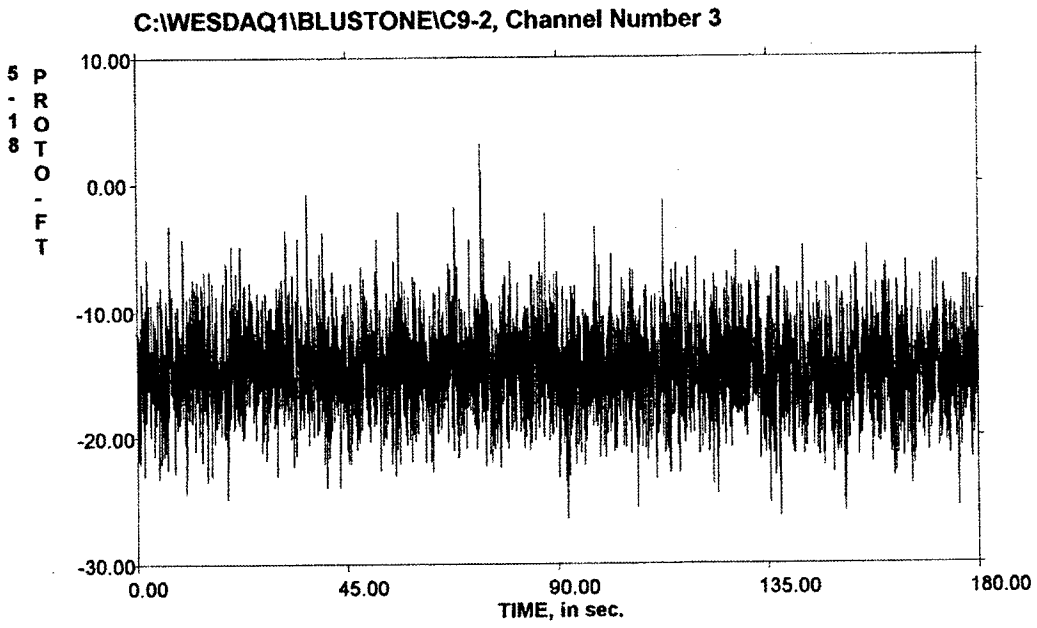

Information File Name: c:\wesdaq1\C9-3.inf
 Sample Rate: 50.000 samples/sec/channel
 Number of Seconds Recorded: 180.000 seconds
 Data Collected on 6/1/00 2:48:08 PM

Bluestone Dam Model
 1:65 Scale

Condition No. 9 Pool Elevation = 1538.9Ft. Prototype
 All 6 channels filtered at 10 Hz. Low Pass
 All calibrations and Data Recorded are in Prototype feet
 All channels are balanced and calibrated at 23.0 Ft. Prototype,
 Model Water Level at top of Stilling Weir.

ISDD Operator: Guy / Ables

STATISTICS						
CHAN	MINIMUM	AVERAGE	MAXIMUM	STANDARD	ROOT MEAN	ENGINEERING UNI
NUM	MEASUREMENT	MEASUREMENT	MEASUREMENT	DEVIATION	SQUARE	
1	-46.414	37.656	70.345	9.927	38.943	PROTO-FT
2	-18.664	-9.911	0.137	2.196	10.152	PROTO-FT
3	-28.983	-14.811	-0.583	3.097	15.132	PROTO-FT
4	-84.773	34.259	69.627	11.535	36.149	PROTO-FT
5	-21.254	-12.616	-5.583	2.078	12.786	PROTO-FT
6	-28.882	-12.448	-0.543	3.637	12.968	PROTO-FT

CALIBRATION INFORMATION							
CHAN	GAIN	BASE	CALSTEP	BASE	CAL STEP	ENGINEERING UNITS	TYPE OF G
NUM		VOLTAGE	VOLTAGE	ENG VALUE	ENG VALUE		
1	1.0	-0.004	1.976	23.000	51.199	PROTO-FT	5-2
2	1.0	-0.004	1.201	23.000	50.701	PROTO-FT	5-11
3	1.0	-0.004	2.060	23.000	48.036	PROTO-FT	5-18
4	1.0	0.008	0.917	23.000	44.900	PROTO-FT	8-2
5	1.0	-0.001	1.058	23.000	51.205	PROTO-FT	8-11
6	1.0	-0.003	1.051	23.000	58.566	PROTO-FT	8-18

C:\WESDAQ1\BLUSTONE\C9-3, Channel Number 1

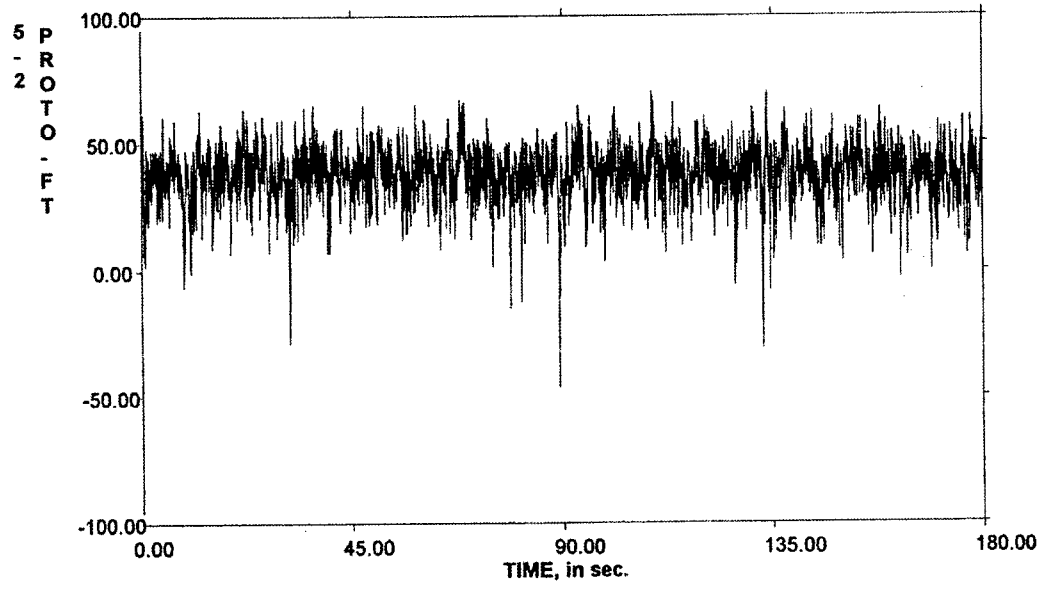

C:\WESDAQ1\BLUSTONE\C9-3, Channel Number 4

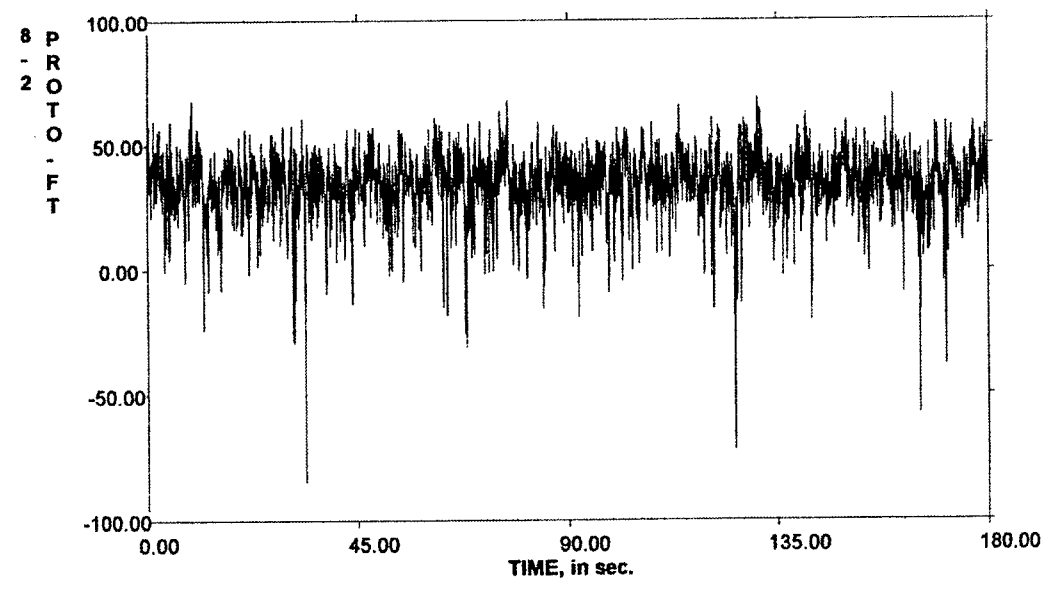

C:\WESDAQ1\BLUSTONE\C9-3, Channel Number 2

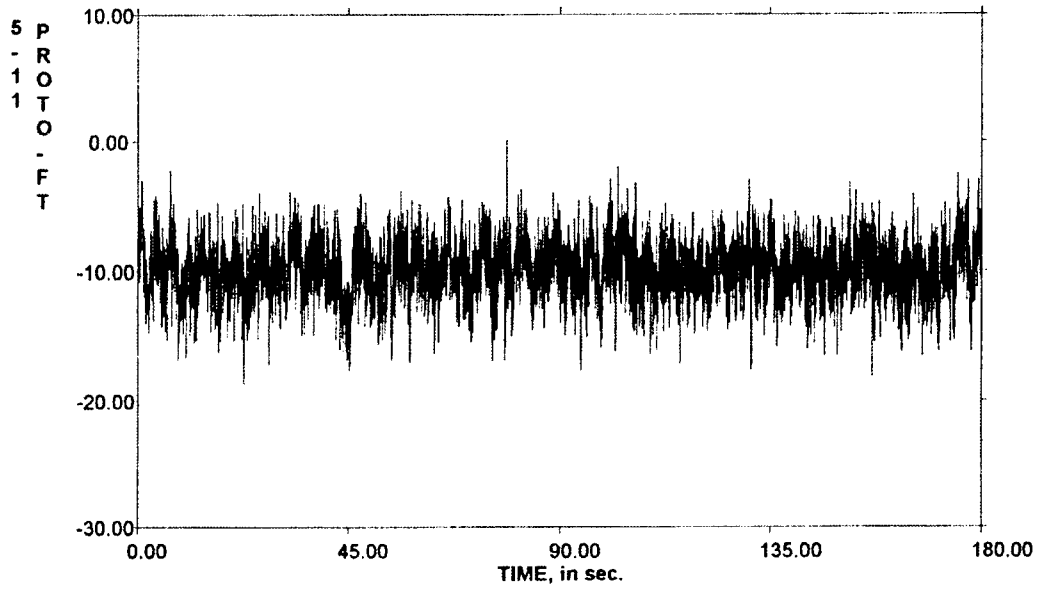

C:\WESDAQ1\BLUSTONE\C9-3, Channel Number 5

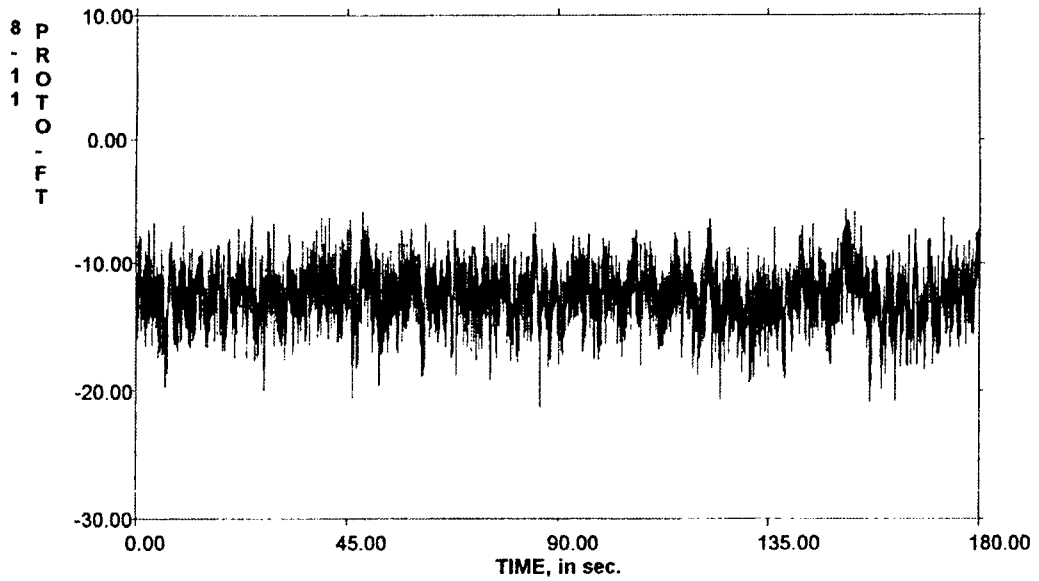

C:\WESDAQ1\BLUSTONE\C9-3, Channel Number 3.

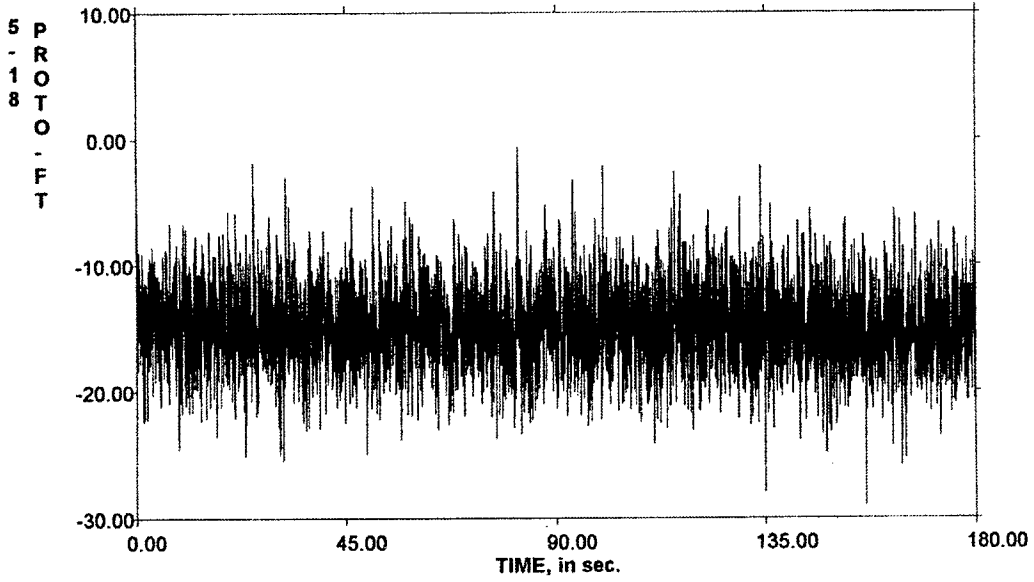

C:\WESDAQ1\BLUSTONE\C9-3, Channel Number 6

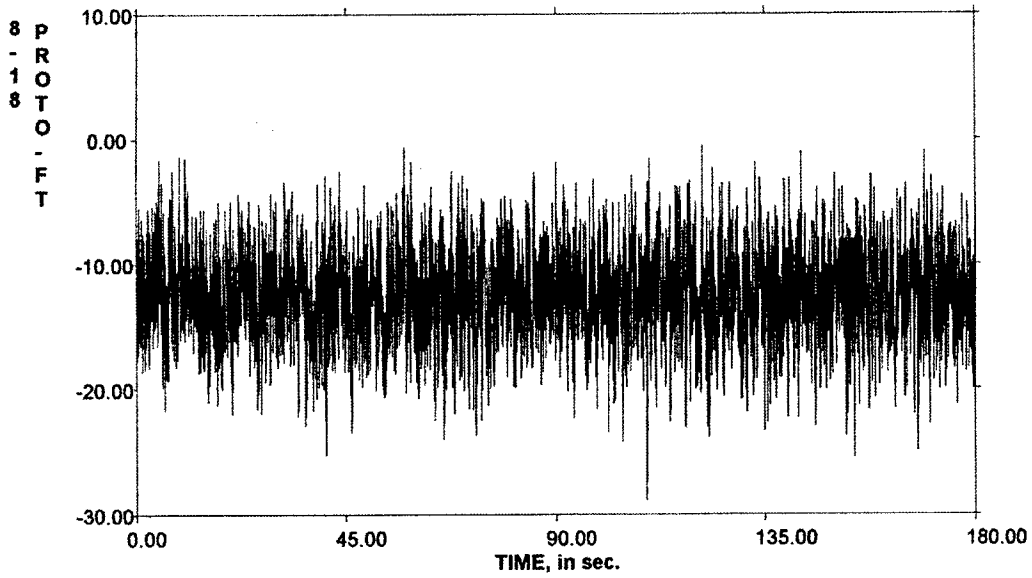

Information File Name: c:\wesdaq2\C10-2.inf
 Sample Rate: 50.000 samples/sec/channel
 Number of Seconds Recorded: 180.000 seconds
 Data Collected on 6/1/00 12:49:36 PM
 Bluestone Dam Model
 1:65 Scale
 Condition No. 10 Pool Elevation = 1546.8 Ft. Prototype
 All 6 channels filtered at 10 Hz. Low Pass
 All calibrations and Data Recorded are in Prototype feet
 All channels are balanced and calibrated at 23.0 Ft. Prototype,
 Model Water Level at top of Stilling Weir.

ISDD Operator: Guy / Ables

STATISTICS						
CHAN	MINIMUM	AVERAGE	MAXIMUM	STANDARD	ROOT MEAN	ENGINEERING UNI
NUM	MEASUREMENT	MEASUREMENT	MEASUREMENT	DEVIATION	SQUARE	
1	-48.153	38.884	65.720	8.792	39.866	PROTO-FT
2	-16.531	-6.681	1.428	2.307	7.068	PROTO-FT
3	-24.156	-13.118	-1.324	3.172	13.496	PROTO-FT
4	-35.071	37.448	63.099	8.790	38.466	PROTO-FT
5	-20.278	-10.437	-1.747	2.339	10.696	PROTO-FT
6	-22.621	-10.846	2.341	3.632	11.438	PROTO-FT

CALIBRATION INFORMATION							
CHAN	GAIN	BASE	CALSTEP	BASE	CAL STEP	ENGINEERING UNITS	TYPE OF G
NUM		VOLTAGE	VOLTAGE	ENG VALUE	ENG VALUE		
1	1.0	-0.004	1.976	23.000	51.199	PROTO-FT	5-2
2	1.0	-0.004	1.201	23.000	50.701	PROTO-FT	5-11
3	1.0	-0.004	2.060	23.000	48.036	PROTO-FT	5-18
4	1.0	0.008	0.917	23.000	44.900	PROTO-FT	8-2
5	1.0	-0.001	1.058	23.000	51.205	PROTO-FT	8-11
6	1.0	-0.003	1.051	23.000	58.566	PROTO-FT	8-18

C:\WESDAQ1\BLUSTONE\C10-2, Channel Number 1

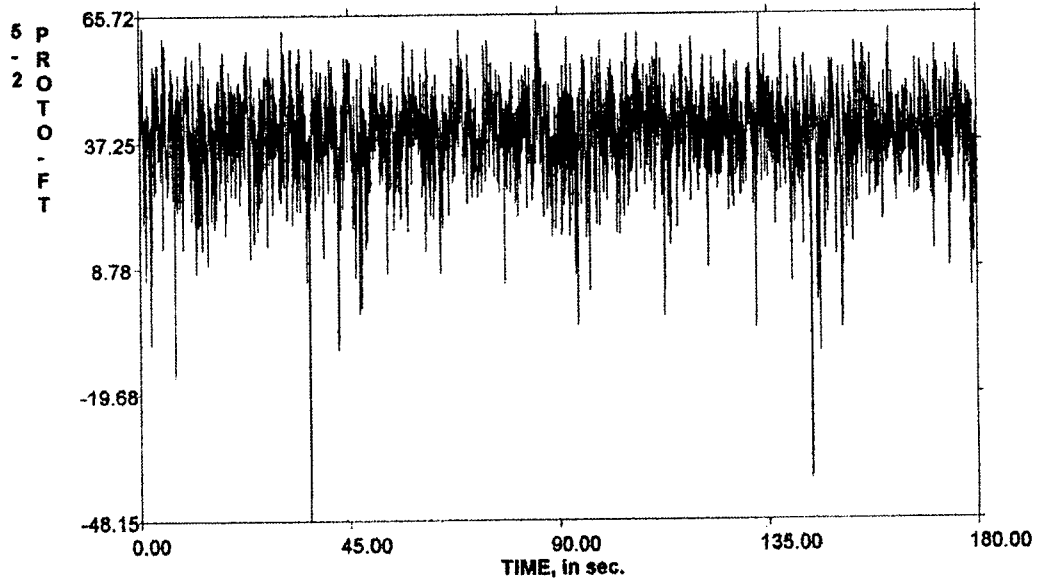

C:\WESDAQ1\BLUSTONE\C10-2, Channel Number 4

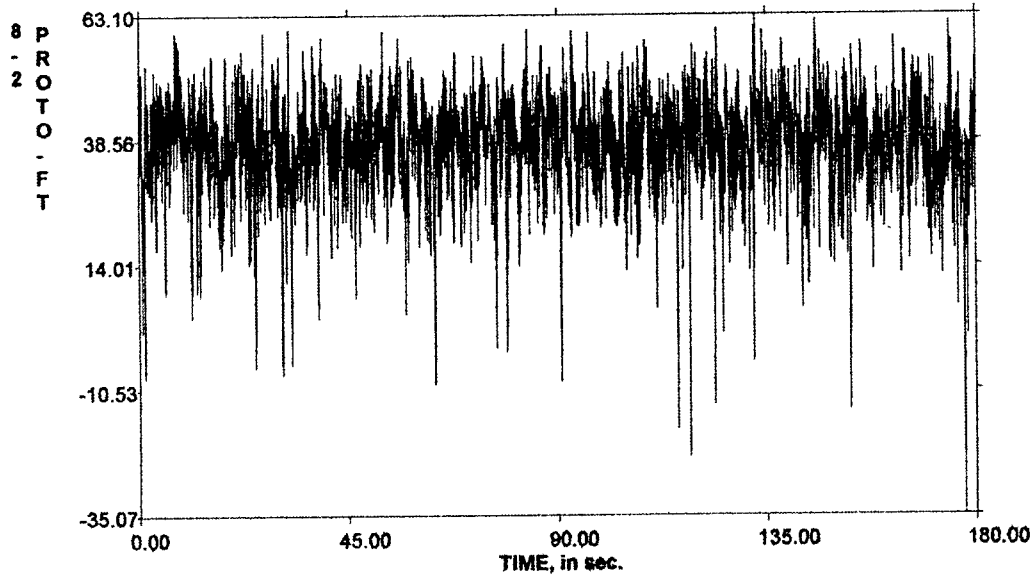

C:\WESDAQ\BLUSTONE\C10-2, Channel Number 2

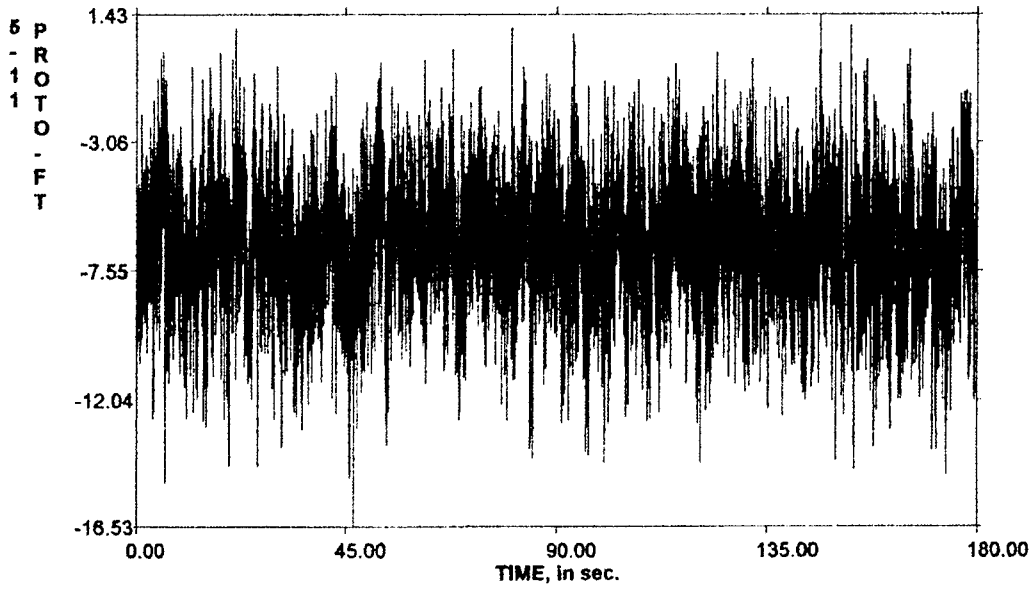

C:\WESDAQ\BLUSTONE\C10-2, Channel Number 5

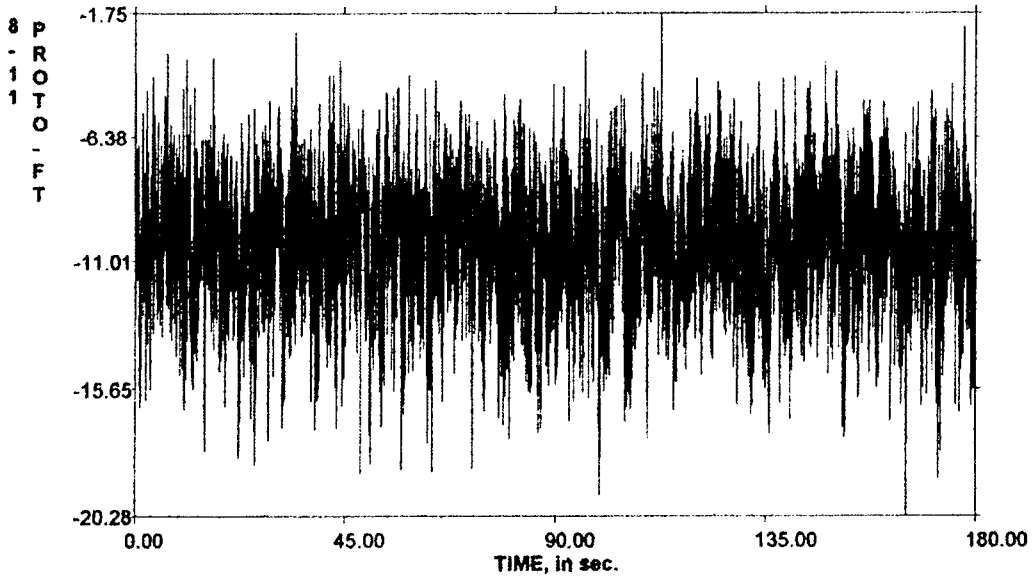

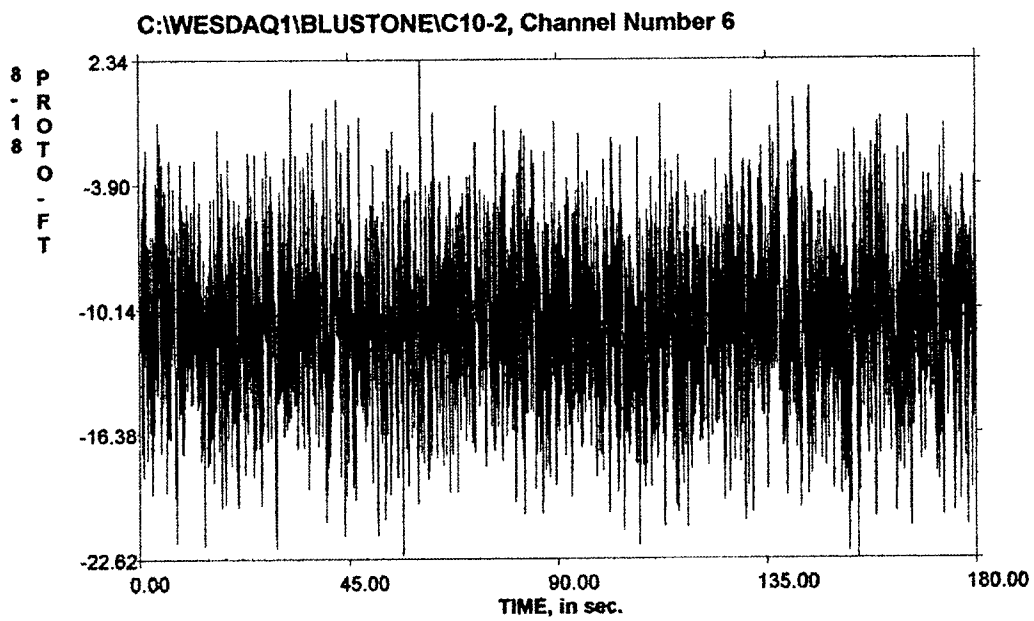
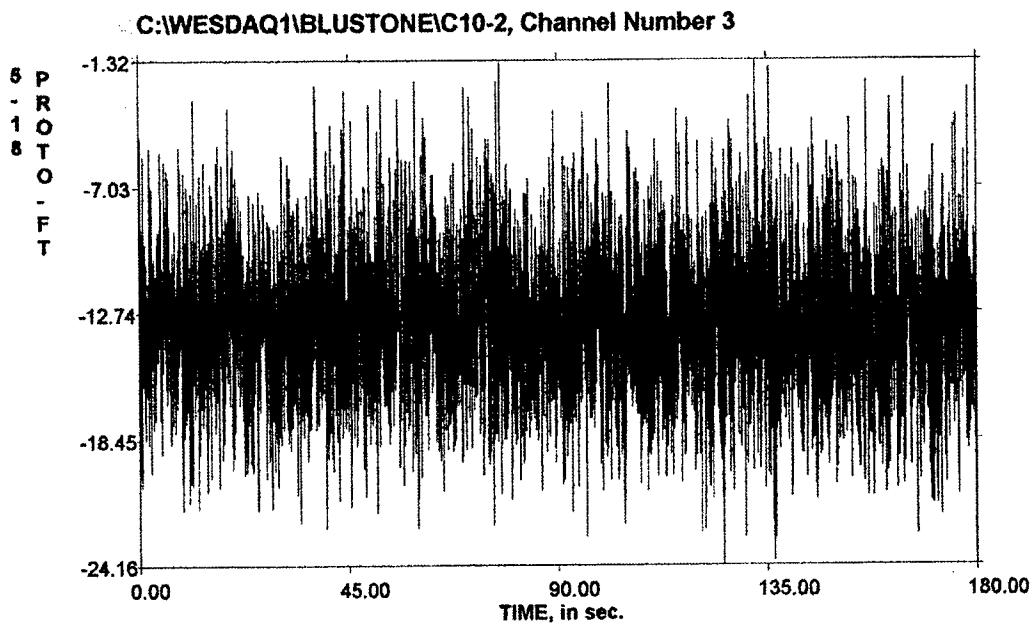

Information File Name: c:\wesdaq2\C10-3.inf
 Sample Rate: 50.000 samples/sec/channel
 Number of Seconds Recorded: 180.000 seconds
 Data Collected on 6/1/00 12:58:14 PM
 Bluestone Dam Model
 1:65 Scale
 Condition No. 10 Pool Elevation = 1546.8 Ft. Prototype
 All 6 channels filtered at 10 Hz. Low Pass
 All calibrations and Data Recorded are in Prototype feet
 All channels are balanced and calibrated at 23.0 Ft. Prototype,
 Model Water Level at top of Stilling Weir.

ISDD Operator: Guy / Ables

STATISTICS						
CHAN	MINIMUM	AVERAGE	MAXIMUM	STANDARD	ROOT MEAN	ENGINEERING UNI
NUM	MEASUREMENT	MEASUREMENT	MEASUREMENT	DEVIATION	SQUARE	
1	-19.015	38.151	65.025	8.527	39.092	PROTO-FT
2	-16.924	-6.991	1.933	2.382	7.386	PROTO-FT
3	-26.407	-13.376	-0.139	3.128	13.737	PROTO-FT
4	-36.894	37.448	66.687	8.793	38.466	PROTO-FT
5	-21.969	-10.615	-1.877	2.443	10.893	PROTO-FT
6	-23.362	-10.875	1.682	3.692	11.485	PROTO-FT

CALIBRATION INFORMATION							
CHAN	GAIN	BASE	CALSTEP	BASE	CAL STEP	ENGINEERING UNITS	TYPE OF G
NUM		VOLTAGE	VOLTAGE	ENG VALUE	ENG VALUE		
1	1.0	-0.004	1.976	23.000	51.199	PROTO-FT	5-2
2	1.0	-0.004	1.201	23.000	50.701	PROTO-FT	5-11
3	1.0	-0.004	2.060	23.000	48.036	PROTO-FT	5-18
4	1.0	0.008	0.917	23.000	44.900	PROTO-FT	8-2
5	1.0	-0.001	1.058	23.000	51.205	PROTO-FT	8-11
6	1.0	-0.003	1.051	23.000	58.566	PROTO-FT	8-18

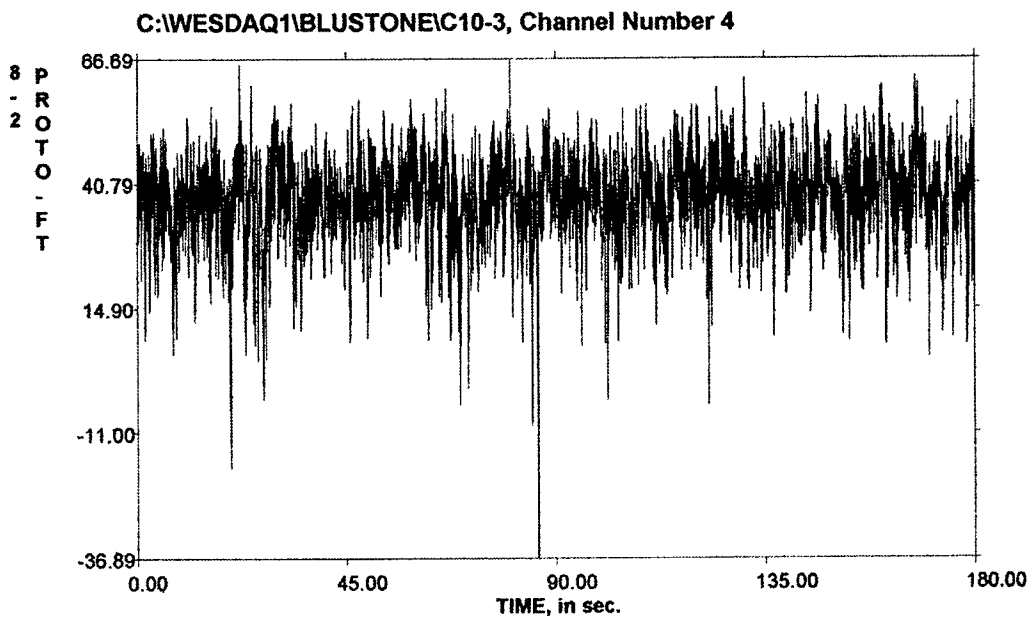
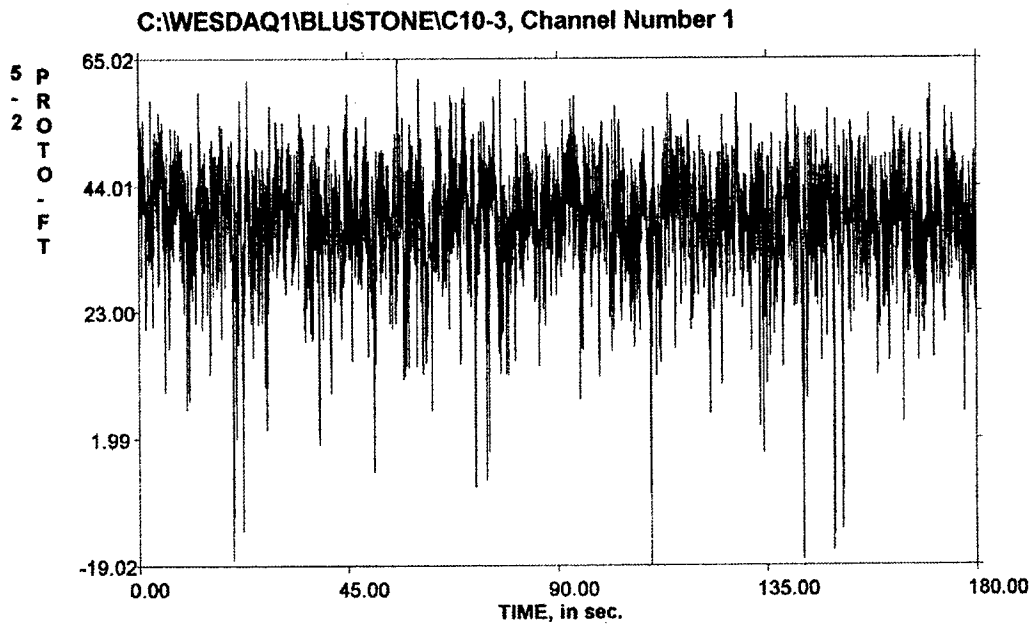

C:\WESDAQ1\BLUSTONE\C10-3, Channel Number 2

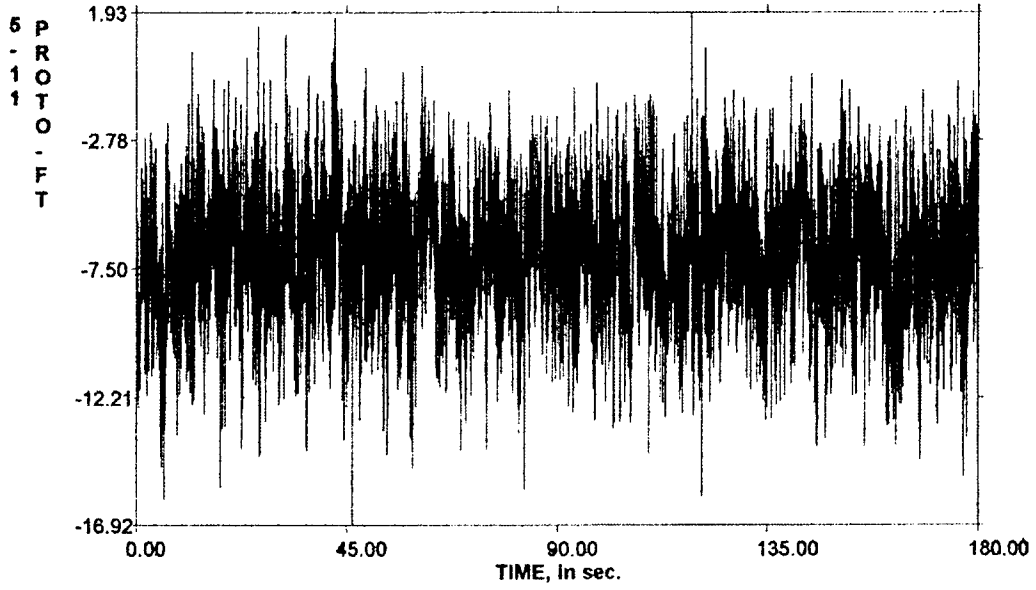

C:\WESDAQ1\BLUSTONE\C10-3, Channel Number 5

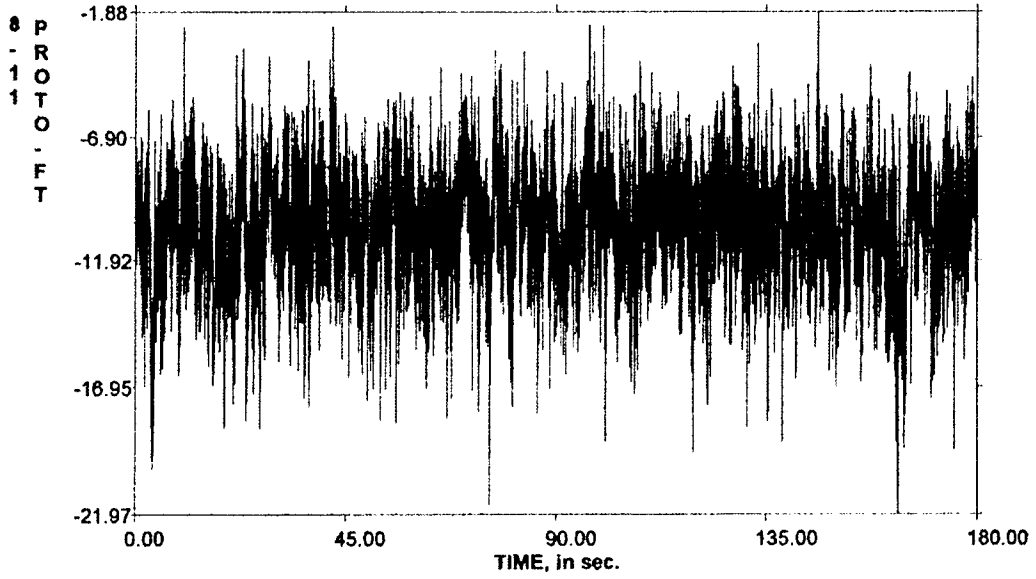

C:\WESDAQ1\BLUSTONEIC10-3, Channel Number 3

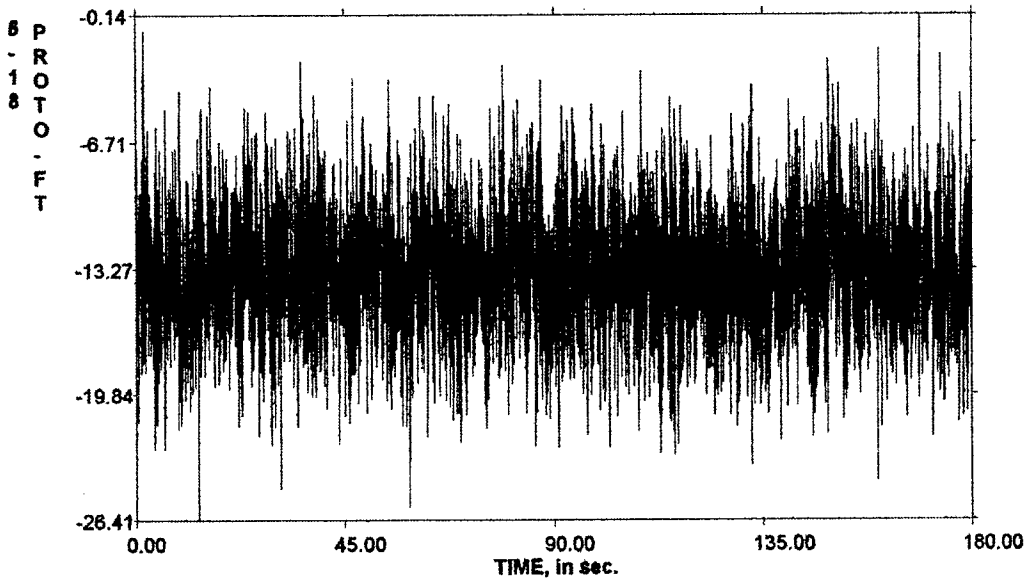

C:\WESDAQ1\BLUSTONEIC10-3, Channel Number 6

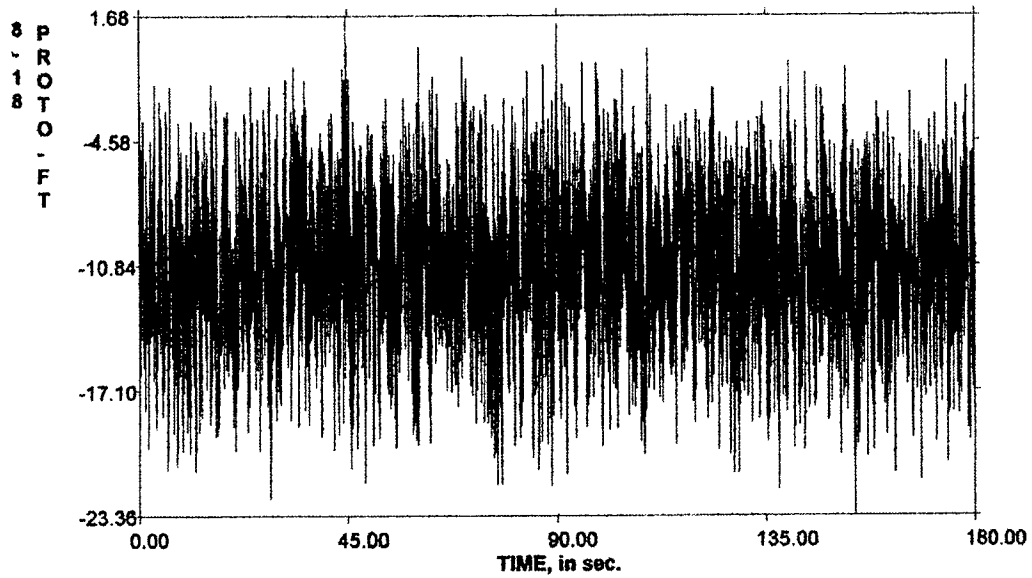

Appendix C

Pressure Cell Data, Spill Gate

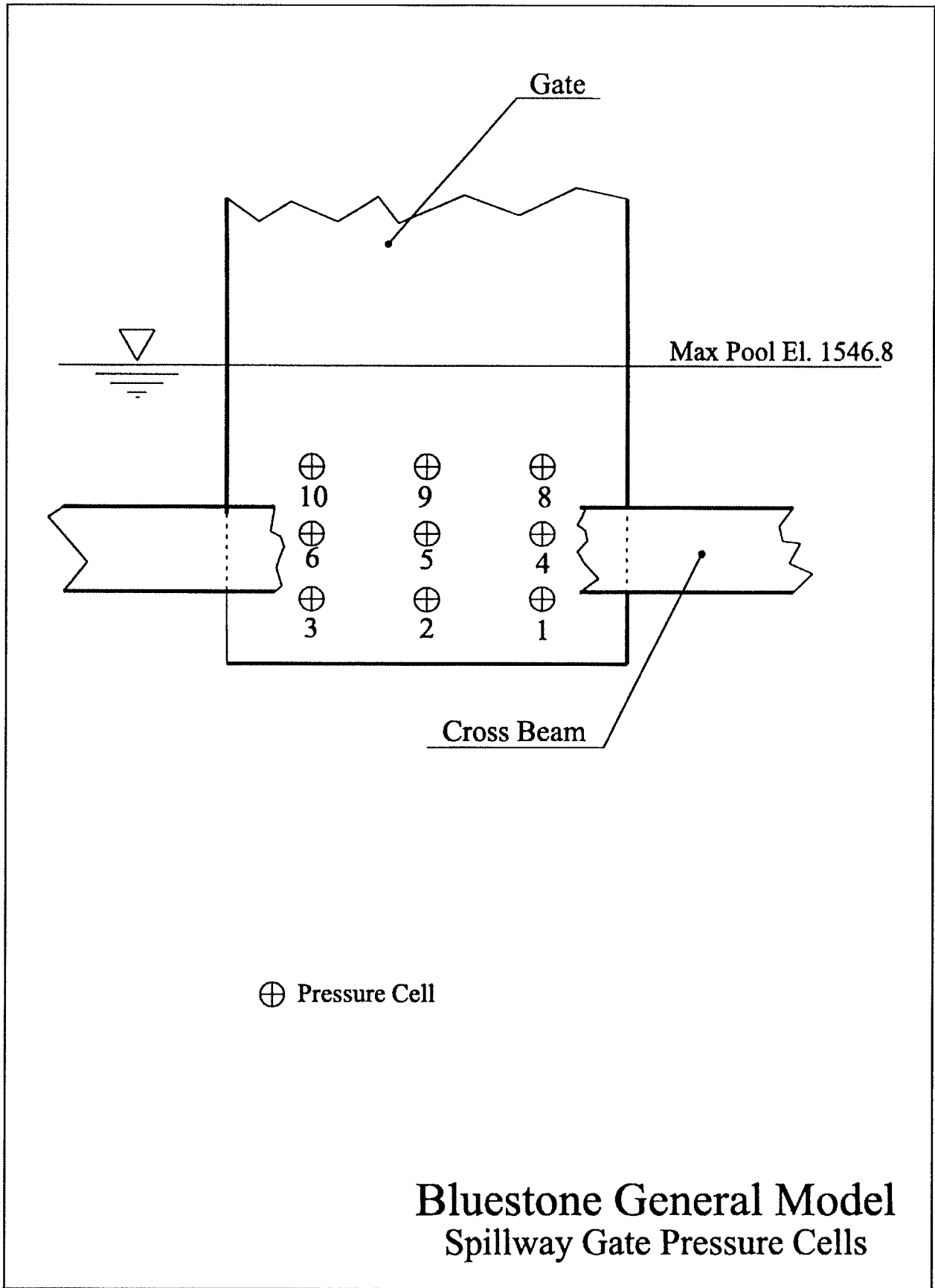

Information File Name: c:\wesdaq2\BSGP01.inf
 Sample Rate: 25.000 samples/sec/channel
 Length of Time Recorded: 00:06:00.00
 Data Collected on 8/18/2000 10:41:17 AM
 Bluestone Model

Gate Pressures

1 Million CFS, Upp Pool - 1546.8 Prototype Ft.
 Lower Pool - 1410.0 Prototype Ft.
 All Channels are filtered at 10 Hz. Low Pass
 Note: A/D Channel No. 7 is Bad. (not being recorded)
 By: Wallace Guy

STATISTICS						
CHAN	MINIMUM	AVERAGE	MAXIMUM	STANDARD	ROOT MEAN	ENGINEERING UNI
NUM	MEASUREMENT	MEASUREMENT	MEASUREMENT	DEVIATION	SQUARE	
1	5.237	6.309	7.831	0.343	6.318	PSI-PROTO
2	4.913	5.920	7.316	0.318	5.929	PSI-PROTO
3	4.571	5.817	7.642	0.390	5.830	PSI-PROTO
4	3.928	4.841	6.016	0.232	4.846	PSI-PROTO
5	3.572	4.629	5.795	0.245	4.635	PSI-PROTO
6	3.591	4.677	5.822	0.253	4.684	PSI-PROTO
8	2.612	3.591	4.479	0.230	3.598	PSI-PROTO
9	2.459	3.656	4.644	0.236	3.663	PSI-PROTO
10	2.791	3.766	4.802	0.236	3.773	PSI-PROTO

CALIBRATION INFORMATION							
CHAN	GAIN	BASE	CALSTEP	BASE	CAL STEP	ENGINEERING UNITS	TYPE OF G
NUM		VOLTAGE	VOLTAGE	ENG VALUE	ENG VALUE		
1	1.0	0.025	4.041	0.000	30.264	PSI-PROTO	PC-1
2	1.0	0.024	4.050	0.000	29.140	PSI-PROTO	PC-2
3	1.0	0.027	4.043	0.000	30.433	PSI-PROTO	PC-3
4	1.0	0.025	4.041	0.000	30.940	PSI-PROTO	PC-4
5	1.0	0.023	4.033	0.000	33.800	PSI-PROTO	PC-5
6	1.0	0.024	4.045	0.000	31.135	PSI-PROTO	PC-6
8	1.0	0.027	4.028	0.000	29.140	PSI-PROTO	PC-7
9	1.0	0.026	4.033	0.000	29.634	PSI-PROTO	PC-8
10	1.0	0.025	4.043	0.000	29.289	PSI-PROTO	PC-9

Channel Numbers

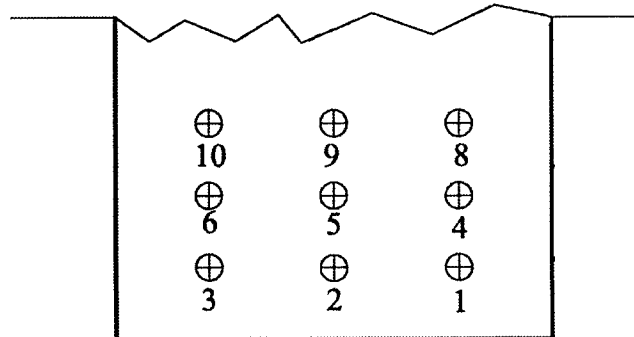

Information File Name: c:\wesdaq2\BSCP02.inf
 Sample Rate: 25.000 samples/sec/channel
 Length of Time Recorded: 00:06:00.00
 Data Collected on 8/18/2000 11:02:53 AM
 Bluestone Model
 1 Million CFS, Upper Pool - 1546.8 Prototype Ft.
 Lower Pool = 1410.0 Prototype Ft.
 All Channels are filtered at 10 Hz. Low Pass
 Note: A/D Channel No. 7 is Bad. (not being recorded)
 By: Wallace Guy

STATISTICS						
CHAN	MINIMUM	AVERAGE	MAXIMUM	STANDARD	ROOT MEAN	ENGINEERING UNI
NUM	MEASUREMENT	MEASUREMENT	MEASUREMENT	DEVIATION	SQUARE	
1	4.981	6.192	8.643	0.370	6.203	PSI-PROTO
2	4.603	5.836	7.947	0.341	5.846	PSI-PROTO
3	4.245	5.723	7.742	0.413	5.738	PSI-PROTO
4	3.588	4.689	6.108	0.249	4.695	PSI-PROTO
5	2.564	4.470	5.764	0.263	4.478	PSI-PROTO
6	3.330	4.547	5.769	0.270	4.555	PSI-PROTO
8	2.471	3.458	4.782	0.244	3.467	PSI-PROTO
9	2.101	3.500	4.764	0.251	3.509	PSI-PROTO
10	2.647	3.614	4.747	0.248	3.623	PSI-PROTO

CALIBRATION INFORMATION							
CHAN	GAIN	BASE	CALSTEP	BASE	CAL STEP	ENGINEERING UNITS	TYPE OF G
NUM		VOLTAGE	VOLTAGE	ENG VALUE	ENG VALUE		
1	2.0	0.050	8.082	0.000	30.264	PSI-PROTO	PC-1
2	2.0	0.048	8.090	0.000	29.140	PSI-PROTO	PC-2
3	2.0	0.054	8.086	0.000	30.433	PSI-PROTO	PC-3
4	2.0	0.050	8.082	0.000	30.940	PSI-PROTO	PC-4
5	2.0	0.046	8.066	0.000	33.800	PSI-PROTO	PC-5
6	2.0	0.048	8.090	0.000	31.135	PSI-PROTO	PC-6
8	2.0	0.054	8.056	0.000	29.140	PSI-PROTO	PC-7
9	2.0	0.052	8.066	0.000	29.634	PSI-PROTO	PC-8
10	2.0	0.050	8.086	0.000	29.289	PSI-PROTO	PC-9

Information File Name: c:\wesdaq2\BSGP03.inf
 Sample Rate: 25.000 samples/sec/channel
 Length of Time Recorded: 00:06:00.00
 Data Collected on 8/18/2000 11:18:24 AM
 Bluestone Model
 1 Million CFS, Upper Pool = 1546.8 Prototype Ft.
 Lower Pool = 1410.0 Prototype Ft.
 All Channels are filtered at 10 Hz. Low Pass
 Note: A/D Channel No. 7 is Bad. (not being recorded)
 By: Wallace Guy

CHAN NUM	MINIMUM MEASUREMENT	AVERAGE MEASUREMENT	STATISTICS			ROOT MEAN SQUARE	ENGINEERING UNI
			MAXIMUM MEASUREMENT	STANDARD DEVIATION			
1	4.751	6.153	7.879	0.351	6.163	PSI-PROTO	
2	4.470	5.775	7.478	0.326	5.785	PSI-PROTO	
3	4.134	5.637	8.213	0.398	5.651	PSI-PROTO	
4	3.419	4.601	5.629	0.242	4.607	PSI-PROTO	
5	3.212	4.398	5.548	0.248	4.405	PSI-PROTO	
6	3.311	4.462	5.797	0.257	4.469	PSI-PROTO	
8	2.213	3.368	4.186	0.241	3.377	PSI-PROTO	
9	2.038	3.398	4.222	0.240	3.406	PSI-PROTO	
10	2.416	3.536	4.374	0.246	3.544	PSI-PROTO	

CHAN NUM	GAIN	BASE VOLTAGE	CALSTEP VOLTAGE	CALIBRATION INFORMATION			ENGINEERING UNITS	TYPE OF G
				BASE ENG VALUE	CAL STEP ENG VALUE			
1	2.0	0.050	8.082	0.000	30.264	PSI-PROTO	PC-1	
2	2.0	0.048	8.090	0.000	29.140	PSI-PROTO	PC-2	
3	2.0	0.054	8.086	0.000	30.433	PSI-PROTO	PC-3	
4	2.0	0.050	8.082	0.000	30.940	PSI-PROTO	PC-4	
5	2.0	0.046	8.066	0.000	33.800	PSI-PROTO	PC-5	
6	2.0	0.048	8.090	0.000	31.135	PSI-PROTO	PC-6	
8	2.0	0.054	8.056	0.000	29.140	PSI-PROTO	PC-7	
9	2.0	0.052	8.066	0.000	29.634	PSI-PROTO	PC-8	
10	2.0	0.050	8.086	0.000	29.289	PSI-PROTO	PC-9	

Information File Name: c:\wesdaq2\BSGP08.inf
 Sample Rate: 25.000 samples/sec/channel
 Length of Time Recorded: 00:06:00.00
 Data Collected on 9/29/2000 8:55:18 AM
 Bluestone Model Gate Pressure Testing
 1 Million CFS, Upper Pool = 1542 Prototype Ft.
 Lower Pool = 1409 Prototype Ft.
 All Channels are filtered at 10 Hz. Low Pass
 Note: A/D Channel No. 7 is Bad. (not being recorded)
 By: Wallace Guy

STATISTICS						
CHAN NUM	MINIMUM MEASUREMENT	AVERAGE MEASUREMENT	MAXIMUM MEASUREMENT	STANDARD DEVIATION	ROOT MEAN SQUARE	ENGINEERING UNI
1	1.782	3.702	6.115	0.529	3.740	PSI-PROTO
2	1.254	3.997	6.589	0.618	4.044	PSI-PROTO
3	1.362	4.310	7.638	0.711	4.368	PSI-PROTO
4	0.212	3.051	5.206	0.398	3.077	PSI-PROTO
5	-0.155	2.886	4.715	0.488	2.927	PSI-PROTO
6	-0.123	3.027	4.804	0.500	3.068	PSI-PROTO
8	-0.274	1.174	3.507	0.605	1.321	PSI-PROTO
9	-0.249	1.139	3.244	0.604	1.289	PSI-PROTO
10	-0.259	1.275	3.305	0.608	1.413	PSI-PROTO

CALIBRATION INFORMATION							
CHAN NUM	GAIN	BASE VOLTAGE	CALSTEP VOLTAGE	BASE ENG VALUE	CAL STEP ENG VALUE	ENGINEERING UNITS	TYPE OF G
1	2.0	0.054	8.136	0.000	30.264	PSI-PROTO	PC-1
2	2.0	0.054	8.162	0.000	29.140	PSI-PROTO	PC-2
3	2.0	0.058	8.144	0.000	30.433	PSI-PROTO	PC-3
4	2.0	0.052	8.144	0.000	30.940	PSI-PROTO	PC-4
5	2.0	0.054	8.120	0.000	33.800	PSI-PROTO	PC-5
6	2.0	0.054	8.170	0.000	31.135	PSI-PROTO	PC-6
8	2.0	0.054	8.146	0.000	29.140	PSI-PROTO	PC-7
9	2.0	0.058	8.136	0.000	29.634	PSI-PROTO	PC-8
10	2.0	0.052	8.138	0.000	29.289	PSI-PROTO	PC-9

Information File Name: c:\wesdaq2\BSGP09.inf
 Sample Rate: 25.000 samples/sec/channel
 Length of Time Recorded: 00:06:00.00
 Data Collected on 9/29/2000 9:27:04 AM
 Bluestone Model Gate Pressure Testing
 1 Million CFS, Upper Pool = 1542 Prototype Ft.
 Lower Pool = 1409 Prototype Ft.
 All Channels are filtered at 10 Hz. Low Pass
 Note: A/D Channel No. 7 is Bad. (not being recorded)
 By: Wallace Guy

CHAN NUM	STATISTICS					ROOT MEAN SQUARE	ENGINEERING UNI
	MINIMUM MEASUREMENT	AVERAGE MEASUREMENT	MAXIMUM MEASUREMENT	STANDARD DEVIATION			
1	2.147	3.732	6.462	0.557		3.773	PSI-PROTO
2	2.254	4.038	6.466	0.630		4.087	PSI-PROTO
3	2.198	4.353	7.353	0.726		4.413	PSI-PROTO
4	0.287	3.030	4.487	0.409		3.058	PSI-PROTO
5	0.848	2.904	4.674	0.504		2.948	PSI-PROTO
6	0.861	3.029	4.822	0.507		3.071	PSI-PROTO
8	-0.326	1.149	3.876	0.638		1.314	PSI-PROTO
9	-0.267	1.116	3.621	0.629		1.281	PSI-PROTO
10	-0.259	1.273	4.304	0.630		1.420	PSI-PROTO

CHAN NUM	GAIN	CALIBRATION INFORMATION				ENGINEERING UNITS	TYPE OF G
		BASE VOLTAGE	CALSTEP VOLTAGE	BASE ENG VALUE	CAL STEP ENG VALUE		
1	2.0	0.054	8.136	0.000	30.264	PSI-PROTO	PC-1
2	2.0	0.054	8.162	0.000	29.140	PSI-PROTO	PC-2
3	2.0	0.058	8.144	0.000	30.433	PSI-PROTO	PC-3
4	2.0	0.052	8.144	0.000	30.940	PSI-PROTO	PC-4
5	2.0	0.054	8.120	0.000	33.800	PSI-PROTO	PC-5
6	2.0	0.054	8.170	0.000	31.135	PSI-PROTO	PC-6
8	2.0	0.054	8.146	0.000	29.140	PSI-PROTO	PC-7
9	2.0	0.058	8.136	0.000	29.634	PSI-PROTO	PC-8
10	2.0	0.052	8.138	0.000	29.289	PSI-PROTO	PC-9

Information File Name: c:\wesdaq2\BSGP10.inf
 Sample Rate: 25.000 samples/sec/channel
 Length of Time Recorded: 00:06:00.00
 Data Collected on 9/29/2000 9:33:57 AM
 Bluestone Model Gate Pressure Testing
 1 Million CFS, Upper Pool = 1542 Prototype Ft.
 Lower Pool = 1409 Prototype Ft.
 All Channels are filtered at 10 Hz. Low Pass
 Note: A/D Channel No. 7 is Bad. (not being recorded)
 By: Wallace Guy

STATISTICS						
CHAN	MINIMUM	AVERAGE	MAXIMUM	STANDARD	ROOT MEAN	ENGINEERING UNI
NUM	MEASUREMENT	MEASUREMENT	MEASUREMENT	DEVIATION	SQUARE	
1	2.065	3.794	6.234	0.517	3.829	PSI-PROTO
2	1.964	4.098	6.624	0.608	4.143	PSI-PROTO
3	2.226	4.375	7.436	0.691	4.430	PSI-PROTO
4	1.071	3.058	4.553	0.379	3.082	PSI-PROTO
5	0.746	2.963	4.592	0.467	3.000	PSI-PROTO
6	0.786	3.069	4.701	0.476	3.106	PSI-PROTO
8	-0.326	1.298	3.331	0.607	1.433	PSI-PROTO
9	-0.320	1.262	3.298	0.605	1.399	PSI-PROTO
10	-0.241	1.400	3.243	0.596	1.521	PSI-PROTO

CALIBRATION INFORMATION							
CHAN	GAIN	BASE	CALSTEP	BASE	CAL STEP	ENGINEERING UNITS	TYPE OF G
NUM		VOLTAGE	VOLTAGE	ENG VALUE	ENG VALUE		
1	2.0	0.054	8.136	0.000	30.264	PSI-PROTO	PC-1
2	2.0	0.054	8.162	0.000	29.140	PSI-PROTO	PC-2
3	2.0	0.058	8.144	0.000	30.433	PSI-PROTO	PC-3
4	2.0	0.052	8.144	0.000	30.940	PSI-PROTO	PC-4
5	2.0	0.054	8.120	0.000	33.800	PSI-PROTO	PC-5
6	2.0	0.054	8.170	0.000	31.135	PSI-PROTO	PC-6
8	2.0	0.054	8.146	0.000	29.140	PSI-PROTO	PC-7
9	2.0	0.058	8.136	0.000	29.634	PSI-PROTO	PC-8
10	2.0	0.052	8.138	0.000	29.289	PSI-PROTO	PC-9

Appendix D Pressure Cell Data, Spillway Pier

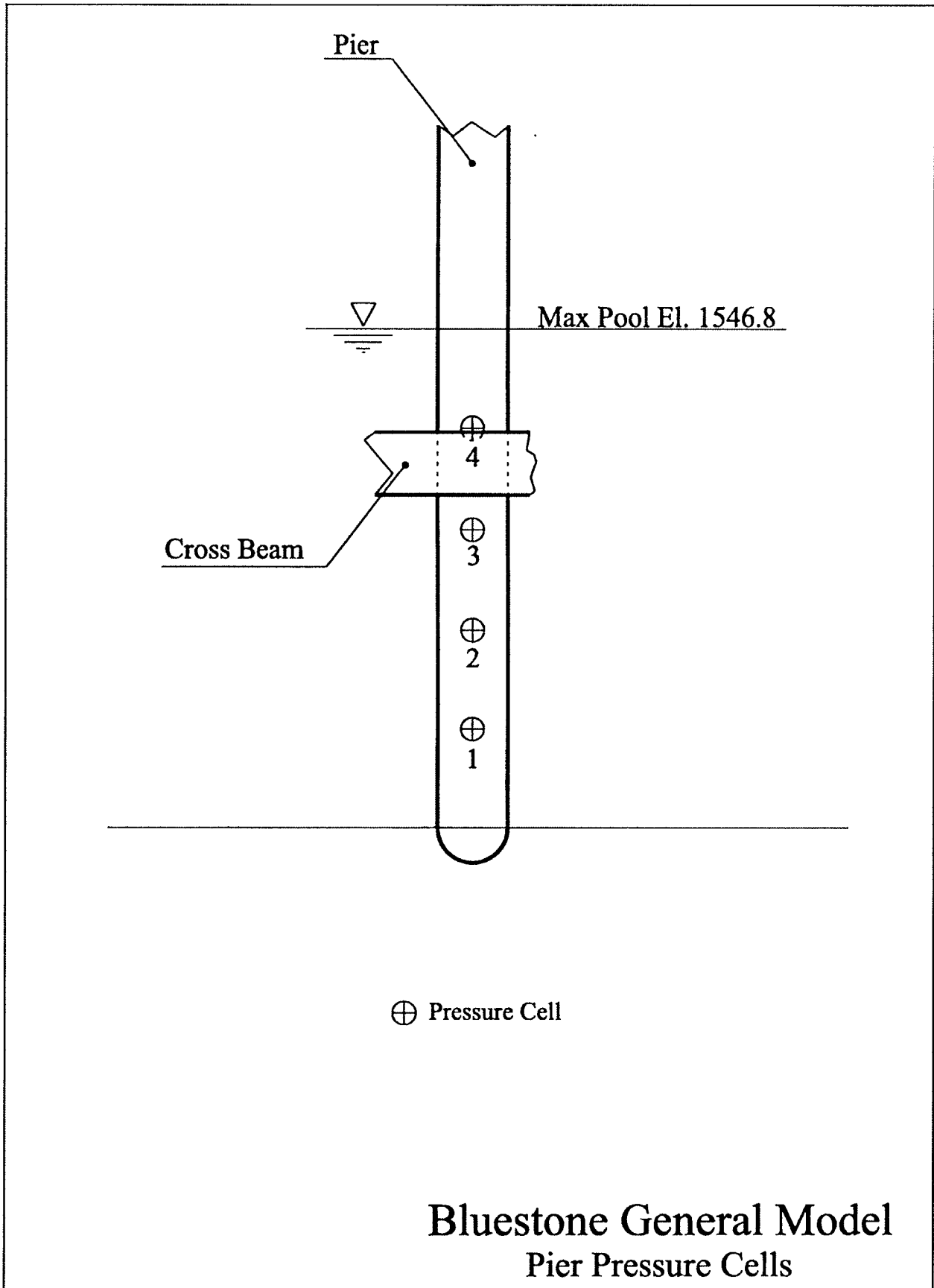

Information File Name: c:\wesdaq2\BSPP04.inf
 Sample Rate: 25.000 samples/sec/channel
 Length of Time Recorded: 00:06:00.00
 Data Collected on 9/26/2000 10:48:02 AM
 Bluestone Model Pier Pressure Testing
 1 Million CFS, Upper Pool = 1542.0 Prototype Ft.
 Lower Pool = 1409.0 Prototype Ft.
 All Channels are filtered at 10 Hz. Low Pass
 Note: A/D Channel No. 7 is Bad. (not being recorded)
 By: Leo Koestler

STATISTICS						
CHAN	MINIMUM	AVERAGE	MAXIMUM	STANDARD	ROOT MEAN	ENGINEERING UNI
NUM	MEASUREMENT	MEASUREMENT	MEASUREMENT	DEVIATION	SQUARE	
1	16.521	17.913	19.405	0.302	17.916	PSI-PROTO
2	12.169	13.179	14.959	0.283	13.182	PSI-PROTO
3	7.008	8.106	9.294	0.289	8.111	PSI-PROTO
4	-0.091	2.769	4.147	0.445	2.805	PSI-PROTO

CALIBRATION INFORMATION							
CHAN	GAIN	BASE	CALSTEP	BASE	CAL STEP	ENGINEERING UNITS	TYPE OF G
NUM		VOLTAGE	VOLTAGE	ENG VALUE	ENG VALUE		
1	1.0	0.029	4.077	0.000	30.264	PSI-PROTO	PC-1
2	2.0	0.058	8.168	0.000	29.140	PSI-PROTO	PC-2
3	2.0	0.058	8.150	0.000	30.433	PSI-PROTO	PC-3
4	2.0	0.058	8.150	0.000	30.940	PSI-PROTO	PC-4

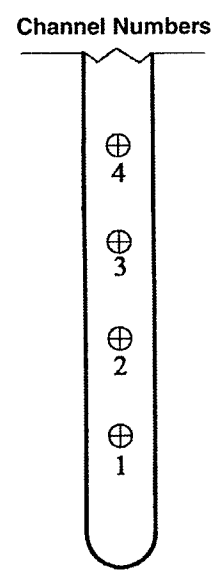

Information File Name: c:\wesdaq2\BSPP05.inf
 Sample Rate: 25.000 samples/sec/channel
 Length of Time Recorded: 00:06:00.00
 Data Collected on 9/26/2000 10:57:07 AM
 Bluestone Model Pier Pressure Testing
 1 Million CFS, Upper Pool = 1542.0 Prototype Ft.
 Lower Pool = 1409.0 Prototype Ft.
 All Channels are filtered at 10 Hz. Low Pass
 Note: A/D Channel No. 7 is Bad. (not being recorded)
 By: Leo Koestler

STATISTICS						
CHAN	MINIMUM	AVERAGE	MAXIMUM	STANDARD	ROOT MEAN	ENGINEERING UNI
NUM	MEASUREMENT	MEASUREMENT	MEASUREMENT	DEVIATION	SQUARE	
1	15.334	17.820	19.551	0.314	17.823	PSI-PROTO
2	12.125	13.070	14.652	0.298	13.074	PSI-PROTO
3	6.971	7.984	9.111	0.281	7.989	PSI-PROTO
4	-0.147	2.632	4.072	0.566	2.692	PSI-PROTO

CALIBRATION INFORMATION							
CHAN	GAIN	BASE	CALSTEP	BASE	CAL STEP	ENGINEERING UNITS	TYPE OF G
NUM		VOLTAGE	VOLTAGE	ENG VALUE	ENG VALUE		
1	1.0	0.029	4.077	0.000	30.264	PSI-PROTO	PC-1
2	2.0	0.058	8.168	0.000	29.140	PSI-PROTO	PC-2
3	2.0	0.058	8.150	0.000	30.433	PSI-PROTO	PC-3
4	2.0	0.058	8.150	0.000	30.940	PSI-PROTO	PC-4

Information File Name: c:\wesdaq2\BSPP06.inf
 Sample Rate: 25.000 samples/sec/channel
 Length of Time Recorded: 00:06:00.00
 Data Collected on 9/26/2000 11:05:48 AM
 Bluestone Model Pier Pressure Testing
 1 Million CFS, Upper Pool = 1542.0 Prototype Ft.
 Lower Pool = 1409.0 Prototype Ft.
 All Channels are filtered at 10 Hz. Low Pass
 Note: A/D Channel No. 7 is Bad. (not being recorded)
 By: Leo Koestler

STATISTICS						
CHAN	MINIMUM	AVERAGE	MAXIMUM	STANDARD	ROOT MEAN	ENGINEERING UNI
NUM	MEASUREMENT	MEASUREMENT	MEASUREMENT	DEVIATION	SQUARE	
1	16.484	17.799	19.697	0.328	17.802	PSI-PROTO
2	11.845	13.058	14.467	0.310	13.062	PSI-PROTO
3	6.953	7.960	9.331	0.303	7.965	PSI-PROTO
4	-0.100	2.609	3.942	0.617	2.681	PSI-PROTO

CALIBRATION INFORMATION						
CHAN	GAIN	BASE	CALSTEP	BASE	CAL STEP	ENGINEERING UNITS
NUM		VOLTAGE	VOLTAGE	ENG VALUE	ENG VALUE	
1	1.0	0.029	4.077	0.000	30.264	PSI-PROTO
2	2.0	0.058	8.168	0.000	29.140	PSI-PROTO
3	2.0	0.058	8.150	0.000	30.433	PSI-PROTO
4	2.0	0.058	8.150	0.000	30.940	PSI-PROTO

Information File Name: C:\WesDaq2\BSPP01Ed.inf
 Sample Rate: 25.000 samples/sec/channel
 Length of Time Recorded: 00:06:00.00
 Data Collected on 9/26/2000 9:51:30 AM
 Bluestone Model Pier Pressure Testing
 1 Million CFS, Upper Pool = 1546.8 Prototype Ft.
 Lower Pool = 1414.0 Prototype Ft.
 All Channels are filtered at 10 Hz. Low Pass
 Note: A/D Channel No. 7 is Bad. (not being recorded)
 By: Leo Koestler

STATISTICS						
CHAN	MINIMUM	AVERAGE	MAXIMUM	STANDARD	ROOT MEAN	ENGINEERING UNI
NUM	MEASUREMENT	MEASUREMENT	MEASUREMENT	DEVIATION	SQUARE	
1	18.529	19.778	21.431	0.320	19.781	PSI-PROTO
2	13.608	15.022	16.599	0.293	15.025	PSI-PROTO
3	8.854	9.904	11.131	0.287	9.908	PSI-PROTO
4	3.269	4.214	5.379	0.272	4.223	PSI-PROTO

CALIBRATION INFORMATION							
CHAN	GAIN	BASE	CALSTEP	BASE	CAL STEP	ENGINEERING UNITS	TYPE OF G
NUM		VOLTAGE	VOLTAGE	ENG VALUE	ENG VALUE		
1	1.0	0.029	4.077	0.000	30.264	PSI-PROTO	PC-1
2	2.0	0.058	8.168	0.000	29.140	PSI-PROTO	PC-2
3	2.0	0.058	8.150	0.000	30.433	PSI-PROTO	PC-3
4	2.0	0.058	8.150	0.000	30.940	PSI-PROTO	PC-4

Information File Name: C:\WesDaq2\BSPP02Ed.inf
 Sample Rate: 25.000 samples/sec/channel
 Length of Time Recorded: 00:06:00.00
 Data Collected on 9/26/2000 10:01:23 AM
 Bluestone Model Pier Pressure Testing
 1 Million CFS, Upper Pool = 1546.8 Prototype Ft.
 Lower Pool = 1414.0 Prototype Ft.
 All Channels are filtered at 10 Hz. Low Pass
 Note: A/D Channel No. 7 is Bad. (not being recorded)
 By: Leo Koestler

STATISTICS						
CHAN	MINIMUM	AVERAGE	MAXIMUM	STANDARD	ROOT MEAN	ENGINEERING UNI
NUM	MEASUREMENT	MEASUREMENT	MEASUREMENT	DEVIATION	SQUARE	
1	18.145	19.797	21.084	0.312	19.800	PSI-PROTO
2	13.555	15.053	16.634	0.294	15.056	PSI-PROTO
3	8.835	9.954	11.222	0.297	9.958	PSI-PROTO
4	3.213	4.238	5.342	0.280	4.247	PSI-PROTO

CALIBRATION INFORMATION							
CHAN	GAIN	BASE	CALSTEP	BASE	CAL STEP	ENGINEERING UNITS	TYPE OF G
NUM		VOLTAGE	VOLTAGE	ENG VALUE	ENG VALUE		
1	1.0	0.029	4.077	0.000	30.264	PSI-PROTO	PC-1
2	2.0	0.058	8.168	0.000	29.140	PSI-PROTO	PC-2
3	2.0	0.058	8.150	0.000	30.433	PSI-PROTO	PC-3
4	2.0	0.058	8.150	0.000	30.940	PSI-PROTO	PC-4

Information File Name: c:\wesdaq2\BSPP03Ed.inf
 Sample Rate: 25.000 samples/sec/channel
 Length of Time Recorded: 00:06:00.00
 Data Collected on 9/26/2000 10:10:42 AM
 Bluestone Model Pier Pressure Testing
 1 Million CFS, Upper Pool = 1546.8 Prototype Ft.
 Lower Pool = 1414.0 Prototype Ft.
 All Channels are filtered at 10 Hz. Low Pass
 Note: A/D Channel No. 7 is Bad. (not being recorded)
 By: Leo Koestler

STATISTICS						
CHAN	MINIMUM	AVERAGE	MAXIMUM	STANDARD	ROOT MEAN	ENGINEERING UNI
NUM	MEASUREMENT	MEASUREMENT	MEASUREMENT	DEVIATION	SQUARE	
1	18.255	19.750	21.650	0.302	19.753	PSI-PROTO
2	13.994	14.984	16.599	0.272	14.986	PSI-PROTO
3	8.229	9.864	11.011	0.273	9.868	PSI-PROTO
4	3.064	4.167	5.314	0.257	4.175	PSI-PROTO

CALIBRATION INFORMATION						
CHAN	GAIN	BASE	CALSTEP	BASE	CAL STEP	ENGINEERING UNITS
NUM		VOLTAGE	VOLTAGE	ENG VALUE	ENG VALUE	
1	1.0	0.029	4.077	0.000	30.264	PSI-PROTO
2	2.0	0.058	8.168	0.000	29.140	PSI-PROTO
3	2.0	0.058	8.150	0.000	30.433	PSI-PROTO
4	2.0	0.058	8.150	0.000	30.940	PSI-PROTO

Appendix E

Pressure Cell Data, Overtopping

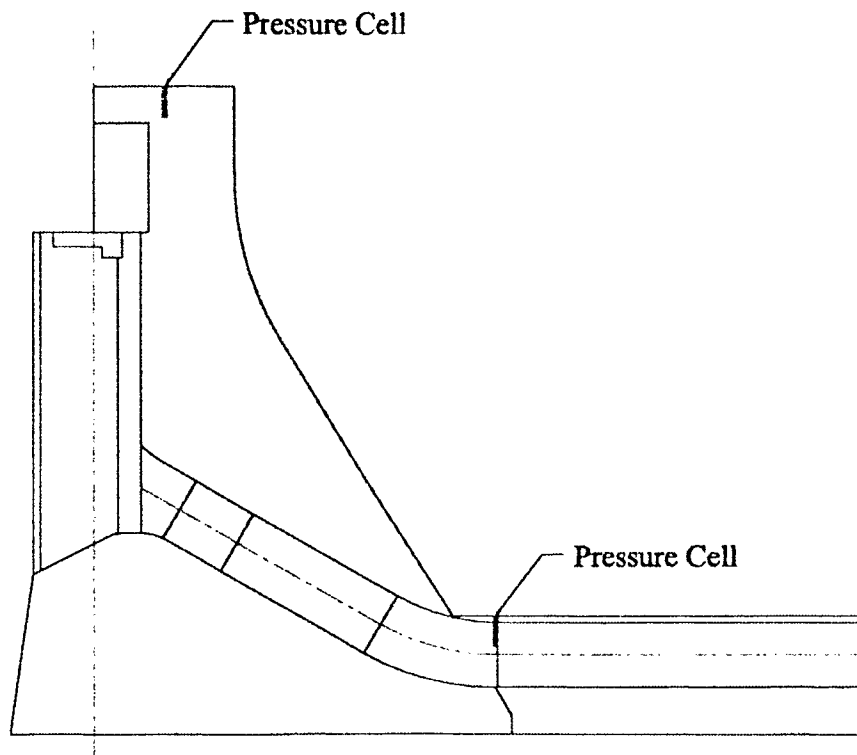

**Bluestone General Model
Intake Overtoppings
Pressure Cell Locations**

Information File Name: c:\wesdaq2\BSOT1.inf
 Sample Rate: 25.000 samples/sec/channel
 Length of Time Recorded: 00:06:00.00
 Data Collected on 10/20/2000 10:29:09 AM
 Bluestone Model Over-Topping Test
 1 Million CFS, Upper Pool = 1546.8 Prototype Ft.
 Lower Pool = 1414 Prototype Ft.
 All Channels are filtered at 10 Hz. Low Pass
 Recording Channel 1 & 2 Only
 Chan.1 located on Crest, Chan.2 on Floor
 By: Wallace Guy

STATISTICS						
CHAN	MINIMUM	AVERAGE	MAXIMUM	STANDARD	ROOT MEAN	ENGINEERING UNI
NUM	MEASUREMENT	MEASUREMENT	MEASUREMENT	DEVIATION	SQUARE	
1	2.484	2.856	3.253	0.098	2.857	PSI-PROTO
2	2.841	12.073	24.745	2.675	12.366	PSI-PROTO

CALIBRATION INFORMATION							
CHAN	GAIN	BASE	CALSTEP	BASE	CAL STEP	ENGINEERING UNITS	TYPE OF G
NUM		VOLTAGE	VOLTAGE	ENG VALUE	ENG VALUE		
1	2.0	0.058	8.126	0.000	30.264	PSI-PROTO	PC-1
2	1.0	0.029	4.063	0.000	29.140	PSI-PROTO	PC-2

Channel Numbers

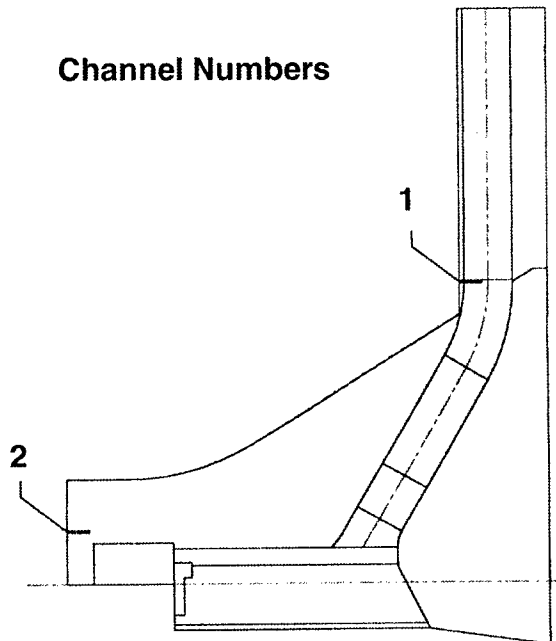

Information File Name: c:\wesdaq2\BSOT2.inf
 Sample Rate: 25.000 samples/sec/channel
 Length of Time Recorded: 00:06:00.00
 Data Collected on 10/20/2000 10:38:04 AM
 Bluestone Model Over-Topping Test
 1 Million CFS, Upper Pool = 1546.8 Prototype Ft.
 Lower Pool = 1414 Prototype Ft.
 All Channels are filtered at 10 Hz. Low Pass
 Recording Channel 1 & 2 Only
 Chan.1 located on Crest, Chan. 2 on Floor
 By: Wallace Guy

STATISTICS					
CHAN	MINIMUM	AVERAGE	MAXIMUM	STANDARD	ROOT MEAN ENGINEERING UNI
NUM	MEASUREMENT	MEASUREMENT	MEASUREMENT	DEVIATION	SQUARE
1	2.374	2.782	3.235	0.089	2.783 PSI-PROTO
2	2.947	11.320	25.891	2.201	11.532 PSI-PROTO

CALIBRATION INFORMATION						
CHAN	GAIN	BASE CALSTEP	BASE	CAL STEP	ENGINEERING UNITS	TYPE OF G
NUM		VOLTAGE	VOLTAGE	ENG VALUE	ENG VALUE	
1	2.0	0.058	8.126	0.000	30.264 PSI-PROTO	PC-1
2	1.0	0.029	4.063	0.000	29.140 PSI-PROTO	PC-2

Information File Name: c:\wesdaq2\BSOT3.inf
 Sample Rate: 25.000 samples/sec/channel
 Length of Time Recorded: 00:06:00.00
 Data Collected on 10/20/2000 10:46:57 AM
 Bluestone Model Over-Topping Test
 1 Million CFS, Upper Pool = 1546.8 Prototype Ft.
 Lower Pool = 1414 Prototype Ft.
 All Channels are filtered at 10 Hz. Low Pass
 Recording Channel 1 & 2 Only
 Chan. 1 located on Crest, Chan. 2 on Floor
 By: Wallace Guy

STATISTICS						
CHAN	MINIMUM	AVERAGE	MAXIMUM	STANDARD	ROOT MEAN	ENGINEERING UNI
NUM	MEASUREMENT	MEASUREMENT	MEASUREMENT	DEVIATION	SQUARE	
1	2.457	2.792	3.143	0.095	2.793	PSI-PROTO
2	2.101	11.007	32.258	2.192	11.223	PSI-PROTO

CALIBRATION INFORMATION							
CHAN	GAIN	BASE	CALSTEP	BASE	CAL STEP	ENGINEERING UNITS	TYPE OF G
NUM		VOLTAGE	VOLTAGE	ENG VALUE	ENG VALUE		
1	2.0	0.058	8.126	0.000	30.264	PSI-PROTO	PC-1
2	1.0	0.029	4.063	0.000	29.140	PSI-PROTO	PC-2

Information File Name: c:\wesdaq2\BSOT4.inf
 Sample Rate: 25.000 samples/sec/channel
 Length of Time Recorded: 00:06:00.00
 Data Collected on 10/20/2000 11:13:17 AM
 Bluestone Model Over-Topping Test
 1 Million CFS, Upper Pool = 1542 Prototype Ft.
 Lower Pool = 1409 Prototype Ft.
 All Channels are filtered at 10 Hz. Low Pass
 Recording Channel 1 & 2 Only
 Chan. 1 located on Crest, Chan. 2 on Floor
 By: Wallace Guy

CHAN NUM	STATISTICS					
	MINIMUM MEASUREMENT	AVERAGE MEASUREMENT	MAXIMUM MEASUREMENT	STANDARD DEVIATION	ROOT MEAN SQUARE	ENGINEERING UNI
1	1.413	1.816	2.566	0.159	1.823	PSI-PROTO
2	-0.791	6.257	11.183	1.996	6.568	PSI-PROTO

CHAN NUM	GAIN	CALIBRATION INFORMATION				ENGINEERING UNITS	TYPE OF G
		BASE VOLTAGE	CALSTEP VOLTAGE	BASE ENG VALUE	CAL STEP ENG VALUE		
1	2.0	0.058	8.126	0.000	30.264	PSI-PROTO	PC-1
2	1.0	0.029	4.063	0.000	29.140	PSI-PROTO	PC-2

Information File Name: c:\wesdaq2\BSOT5.inf
 Sample Rate: 25.000 samples/sec/channel
 Length of Time Recorded: 00:06:00.00
 Data Collected on 10/20/2000 11:22:30 AM
 Bluestone Model Over-Topping Test
 1 Million CFS, Upper Pool = 1542 Prototype Ft.
 Lower Pool = 1409 Prototype Ft.
 All Channels are filtered at 10 Hz. Low Pass
 Recording Channel 1 & 2 Only
 Chan. 1 located on Crest, Chan. 2 on Floor
 By: Wallace Guy

STATISTICS						
CHAN	MINIMUM	AVERAGE	MAXIMUM	STANDARD	ROOT MEAN	ENGINEERING UNI
NUM	MEASUREMENT	MEASUREMENT	MEASUREMENT	DEVIATION	SQUARE	
1	1.367	1.768	2.392	0.132	1.773	PSI-PROTO
2	-0.853	6.212	11.192	1.934	6.507	PSI-PROTO

CALIBRATION INFORMATION						
CHAN	GAIN	BASE	CALSTEP	BASE	CAL STEP	ENGINEERING UNITS
NUM		VOLTAGE	VOLTAGE	ENG VALUE	ENG VALUE	
1	2.0	0.058	8.126	0.000	30.264	PSI-PROTO
2	2.0	0.058	8.126	0.000	29.140	PSI-PROTO

Information File Name: c:\wesdaq2\BSOT6.inf
 Sample Rate: 25.000 samples/sec/channel
 Length of Time Recorded: 00:06:00.00
 Data Collected on 10/20/2000 11:30:26 AM
 Bluestone Model Over-Topping Test
 1 Million CFS, Upper Pool = 1542 Prototype Ft.
 Lower Pool = 1409 Prototype Ft.
 All Channels are filtered at 10 Hz. Low Pass
 Recording Channel 1 & 2 Only
 Chan. 1 located on Crest, Chan. 2 on Floor
 By: Wallace Guy

STATISTICS						
CHAN	MINIMUM	AVERAGE	MAXIMUM	STANDARD	ROOT MEAN	ENGINEERING UNI
NUM	MEASUREMENT	MEASUREMENT	MEASUREMENT	DEVIATION	SQUARE	
1	1.348	1.743	2.319	0.131	1.748	PSI-PROTO
2	-0.783	6.063	11.571	1.912	6.357	PSI-PROTO

CALIBRATION INFORMATION							
CHAN	GAIN	BASE	CALSTEP	BASE	CAL STEP	ENGINEERING UNITS	TYPE OF G
NUM		VOLTAGE	VOLTAGE	ENG VALUE	ENG VALUE		
1	2.0	0.058	8.126	0.000	30.264	PSI-PROTO	PC-1
2	2.0	0.058	8.126	0.000	29.140	PSI-PROTO	PC-2

Appendix F

Nappe Profile for Probable Maximum Flood

The nappe profile for the Probable Maximum Flood (PMF) was documented (Figure F1) to provide information for use during the construction of the Bluestone Lake Dam modifications. This information will assist in designing temporary training walls for isolation of a portion of the spillway.

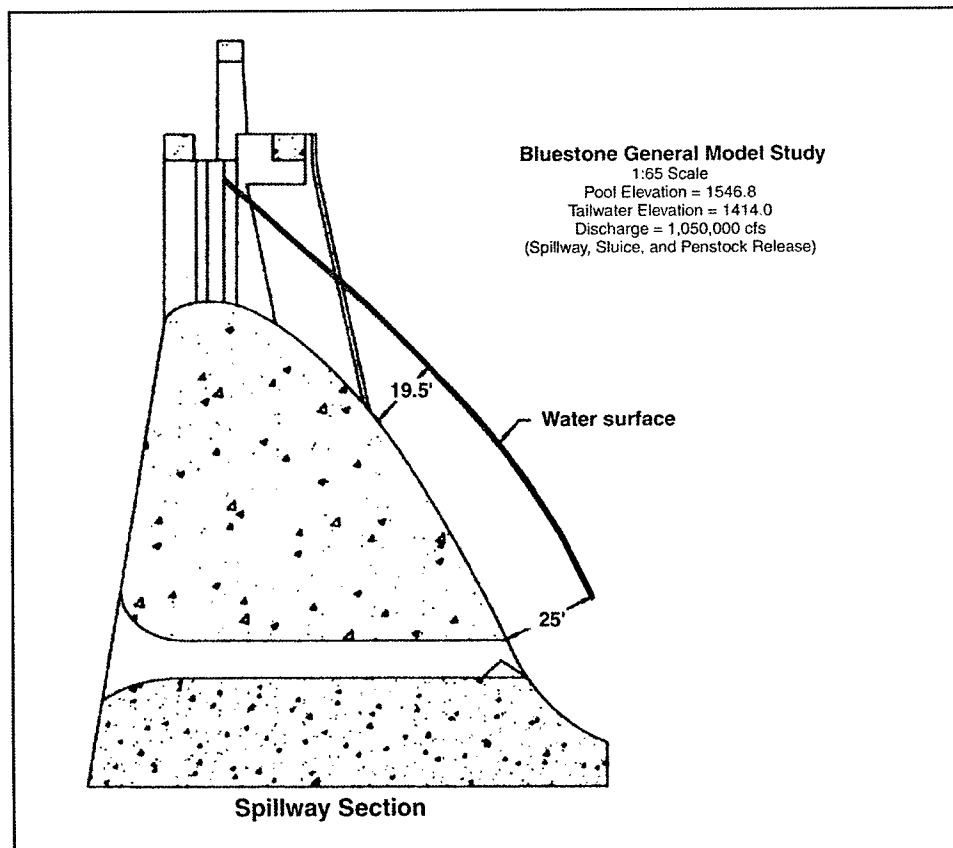

Figure F1. Nappe profile during PMF

REPORT DOCUMENTATION PAGE

Form Approved
OMB No. 0704-0188

Public reporting burden for this collection of information is estimated to average 1 hour per response, including the time for reviewing instructions, searching existing data sources, gathering and maintaining the data needed, and completing and reviewing this collection of information. Send comments regarding this burden estimate or any other aspect of this collection of information, including suggestions for reducing this burden to Department of Defense, Washington Headquarters Services, Directorate for Information Operations and Reports (0704-0188), 1215 Jefferson Davis Highway, Suite 1204, Arlington, VA 22202-4302. Respondents should be aware that notwithstanding any other provision of law, no person shall be subject to any penalty for failing to comply with a collection of information if it does not display a currently valid OMB control number. **PLEASE DO NOT RETURN YOUR FORM TO THE ABOVE ADDRESS.**

1. REPORT March 2002	2. REPORT TYPE Final report	3. DATES COVERED (From - To)												
4. TITLE AND SUBTITLE Bluestone Lake Dam, West Virginia, Rating Curve and Overtopping Study		5a. CONTRACT NUMBER												
		5b. GRANT NUMBER												
		5c. PROGRAM ELEMENT NUMBER												
6. AUTHOR(S) Billy D. Fuller		5d. PROJECT NUMBER												
		5e. TASK NUMBER												
		5f. WORK UNIT NUMBER 005CWK												
7. PERFORMING ORGANIZATION NAME(S) AND ADDRESS(ES) U.S. Army Engineer Research and Development Center Coastal and Hydraulics Laboratory 3909 Halls Ferry Road Vicksburg, MS 39180-6199		8. PERFORMING ORGANIZATION REPORT NUMBER ERDC/CHL TR-02-2												
		10. SPONSOR/MONITOR'S ACRONYM(S)												
9. SPONSORING / MONITORING AGENCY NAME(S) AND ADDRESS(ES) U.S. Army Engineer District, Huntington Huntington, WV 25701-2070		11. SPONSOR/MONITOR'S REPORT NUMBER(S)												
		12. DISTRIBUTION / AVAILABILITY STATEMENT Approved for public release; distribution is unlimited.												
13. SUPPLEMENTARY NOTES														
14. ABSTRACT Experiments were conducted on a 1:65 scale model of the Bluestone Lake Dam located on the New River in West Virginia. The model was constructed to evaluate proposed structural modifications to increase the discharge capacity of the dam.														
15. SUBJECT TERMS <table style="width: 100%; border: none;"> <tr> <td style="width: 20%;">Basin pressures</td> <td style="width: 20%;">Gate forces</td> <td style="width: 20%;">Overtopping</td> <td style="width: 20%;">Rating curve</td> <td style="width: 20%;">Spillway pressures</td> </tr> <tr> <td>Forces</td> <td>Hydraulic models</td> <td>Penstock discharge</td> <td>Spillway</td> <td></td> </tr> </table>					Basin pressures	Gate forces	Overtopping	Rating curve	Spillway pressures	Forces	Hydraulic models	Penstock discharge	Spillway	
Basin pressures	Gate forces	Overtopping	Rating curve	Spillway pressures										
Forces	Hydraulic models	Penstock discharge	Spillway											
16. SECURITY CLASSIFICATION OF:			17. LIMITATION OF ABSTRACT	18. NUMBER OF PAGES										
a. REPORT UNCLASSIFIED	b. ABSTRACT UNCLASSIFIED	c. THIS PAGE UNCLASSIFIED	UNCLASSIFIED	194										
19a. NAME OF RESPONSIBLE PERSON														
19b. TELEPHONE NUMBER (include area code)														