

## Weather Impact Decision Aids (WIDA)

Melanie J. Gouveia  
Richard B. Bensinger  
Jeffrey S. Morrison

TASC  
55 Walkers Brook Drive  
Reading, MA 01867

Scientific Report No. 1  
27 September 1999

Approved for Public Release; Distribution is Unlimited

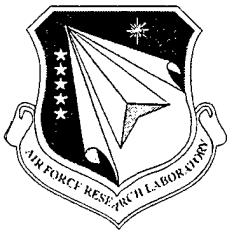

**AIR FORCE RESEARCH LABORATORY**  
**Space Vehicles Directorate**  
**29 Randolph Rd**  
**AIR FORCE MATERIEL COMMAND**  
**Hanscom AFB, MA 01731-3010**

---

20020415 031

"This technical report has been reviewed and is approved for publication"

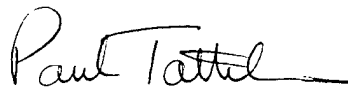

---

PAUL TATTELMAN  
Contract Manager



---

ROBERT R. BELAND, Chief  
Tactical Environmental Support Branch

Qualified requestors may obtain additional copies from the Defense Technical Information Center (DTIC). All others should apply to the National Technical Information Service (NTIS).

If your address has changed, if you wish to be removed from the mailing list, or if the addressee is no longer employed by your organization, please notify AFRL/VSOS-IM, 29 Randolph Road, Hanscom AFB, MA 01731-3010. This will assist in maintaining a current mailing list.

Do not return copies of this report unless contractual obligations or notices on a specific document require that it be returned.

**REPORT DOCUMENTATION PAGE**

Form Approved  
OMB No. 0704-0188

The public reporting burden for this collection of information is estimated to average 1 hour per response, including the time for reviewing instructions, searching existing data sources, gathering and maintaining the data needed, and completing and reviewing the collection of information. Send comments regarding this burden estimate or any other aspect of this collection of information, including suggestions for reducing the burden, to Department of Defense, Washington Headquarters Services, Directorate for Information Operations and Reports (0704-0188), 1215 Jefferson Davis Highway, Suite 1204, Arlington, VA 22202-4302. Respondents should be aware that notwithstanding any other provision of law, no person shall be subject to any penalty for failing to comply with a collection of information if it does not display a currently valid OMB control number.

**PLEASE DO NOT RETURN YOUR FORM TO THE ABOVE ADDRESS.**

1. REPORT DATE (DD-MM-YYYY) 27-09-1999		2. REPORT TYPE Scientific, Interim No. 1		3. DATES COVERED (From - To) 22 Aug 1997-31 Aug 1998	
4. TITLE AND SUBTITLE Weather Impact Decision Aids (WIDA)				5a. CONTRACT NUMBER F19628-97-C-0087	
				5b. GRANT NUMBER	
				5c. PROGRAM ELEMENT NUMBER 63707F	
6. AUTHOR(S) Melanie J. Gouveia Richard B. Bensinger Jeffrey S. Morrison				5d. PROJECT NUMBER 2688	
				5e. TASK NUMBER GU	
				5f. WORK UNIT NUMBER NA	
7. PERFORMING ORGANIZATION NAME(S) AND ADDRESS(ES) TASC 55 Walkers Brook Drive Reading, MA 01867				8. PERFORMING ORGANIZATION REPORT NUMBER	
9. SPONSORING/MONITORING AGENCY NAME(S) AND ADDRESS(ES) Air Force Research Laboratory/VSBL 29 Randolph Road Hanscom AFB, MA 01731-3010				10. SPONSOR/MONITOR'S ACRONYM(S)	
				11. SPONSOR/MONITOR'S REPORT NUMBER(S) AFRL-VS-TR-2000-1509	
12. DISTRIBUTION/AVAILABILITY STATEMENT Approved for public release; distribution unlimited					
13. SUPPLEMENTARY NOTES					
14. ABSTRACT Weather Impact Decision Aids (WIDAs) predict the effects of weather and other environmental factors on the performance of electro-optical (EO) (infrared, visible, and laser) weapons systems. WIDAs will be used to support mission planning and execution. This report summarizes development progress from August 1998 through August 1998. The WIDA program is broken down into two software development programs. The Weather Automated Mission Planning Software (WAMPS) will be a demonstratable system showing how weather decision aids can benefit mission planning. The Target Acquisition Weather Software (TAWS) will be fielded to replace the aging DOS-based Electro-Optical Tactical Decision Aid (EOTDA) software. TAWS takes advantage of the latest hardware and software technology improvements and will integrate advances in environmental effects modeling. TAWS will also leverage developments already underway at the Air Force Research Laboratory (AFRL) in its Infrared Target Scene Simulation (IRTSS) and Night Vision Goggles Operations Weather Software (NOWS) programs. Together, these programs will significantly enhance support to the warfighter. When hundreds to thousands of sorties may be flown over a very short period of time using precision guided munitions, automation and inclusion of weather effects is essential.					
15. SUBJECT TERMS Mission planning      Tactical decision aid      Laser-guided weapons      Target contrast model Mission execution      IR weapons      Sensor performance model      Target detection Precision guided munitions      TV weaponsI      Atmospheric transmission model      Weather forecasts Geographic databases					
16. SECURITY CLASSIFICATION OF:			17. LIMITATION OF ABSTRACT	18. NUMBER OF PAGES	19a. NAME OF RESPONSIBLE PERSON
a. REPORT UNCL	b. ABSTRACT UNCL	c. THIS PAGE UNCL			Paul Tattelman
			SAR	64	19b. TELEPHONE NUMBER (Include area code) (781) 377-5956

## TABLE OF CONTENTS

<b>1</b>	<b>INTRODUCTION</b> .....	<b>1</b>
1.1	OBJECTIVES .....	1
1.1.1	Task 1: Weather Automated Mission Planning Software (WAMPS) .....	1
1.1.2	Task 2: Target Acquisition Weather Software (TAWS).....	2
1.1.3	Task 3: Documentation .....	2
1.2	PROGRESS SUMMARY.....	3
1.3	REPORT ORGANIZATION.....	3
<b>2</b>	<b>TASK 1: WEATHER AUTOMATED MISSION PLANNING SOFTWARE (WAMPS)</b> .....	<b>5</b>
2.1	REQUIREMENTS ANALYSIS .....	5
2.2	PROTOTYPES .....	7
2.3	DEMONSTRATION OF VALUE ADDED BY WAMPS TO THE MISSION PLANNING PROCESS .....	7
<b>3</b>	<b>TASK 2: TARGET ACQUISITION WEATHER SOFTWARE (TAWS)</b> .....	<b>9</b>
3.1	TAWS SYSTEM ARCHITECTURE.....	9
3.2	TAWS GRAPHICAL USER INTERFACE (GUI).....	12
3.3	TAWS OUTPUT PRODUCTS.....	13
3.4	PHYSICAL MODELS .....	13
3.5	AUTOMATED WEATHER.....	13
3.6	GEOGRAPHIC DATABASES.....	14
3.7	CUSTOMIZED SENSORS .....	14
3.8	CUSTOMIZED TARGETS.....	14
3.9	VISUALIZATION .....	14
3.10	ARMY AND NAVY INCLUSION INTO TAWS.....	15
<b>4</b>	<b>TASK 3: DOCUMENTATION</b> .....	<b>17</b>
4.1	QUARTERLY PROGRESS REPORTS .....	17
4.2	PERIODIC BRIEFINGS .....	17

4.3 SOFTWARE DOCUMENTATION.....	17
5 PLANS FOR NEXT YEAR.....	19
REFERENCES.....	21
APPENDIX A: WAMPS REQUIREMENTS DEFINITION .....	23
APPENDIX B: TAWS SYSTEM CONCEPT OF OPERATIONS .....	31

## LIST OF FIGURES

Figure 1. WIDA Project Schedule. ....	2
Figure 2. TAWS Architecture Concept.....	10
Figure 3. TAWS Process Flow Concept. ....	11
Figure 4. TAWS Data Flow Concept.....	11
Figure 5. TAWS GUI Concept. ....	12
Figure 6. Samples of the TAWS GUI. ....	13

# 1 INTRODUCTION

The purpose of this contract is to develop software to predict the effects of weather and other environmental factors on the performance of electro-optical (EO) (infrared, visible, and laser) weapons systems. These Weather Impact Decision Aids (WIDAs) will be used to support the mission planning and mission execution process. The WIDA program is broken down into two software development programs. The Weather Automated Mission Planning Software (WAMPS) will be a demonstratable system showing how weather decision aids can benefit the mission planning process. The Target Acquisition Weather Software (TAWs) will be fielded to replace the aging DOS-based Electro-Optical Tactical Decision Aid (EOTDA) software. TAWs takes advantage of the latest hardware and software technology improvements, and will integrate advances in environmental effects modeling. Additionally, TAWs will leverage developments already underway at the Air Force Research Laboratory (AFRL) in its Infrared Target Scene Simulation (IRTSS) and Night Vision Goggles Operations Weather Software (NOWS) programs. Together, these programs will significantly enhance support to the warfighter. In the modern era when hundreds to thousands of sorties may be flown over a very short period of time using precision guided munitions, automation and the inclusion of mission-limiting weather effects is essential.

## 1.1 OBJECTIVES

The WIDA work is divided into three task areas and is being conducted over an approximately four-year period. The WIDA project schedule is shown in Figure 1. A brief description of the task areas is provided below.

### 1.1.1 Task 1: Weather Automated Mission Planning Software (WAMPS)

A demonstratable Weather Automated Mission Planning Software (WAMPS) system will be incrementally developed. WAMPS will be capable of showing how weather decision aids can support and improve the mission planning process. WAMPS will demonstrate how WIDAs can be used as force multipliers in automated mission planning systems by facilitating the effective use of EO weapon systems against enemy targets. The WAMPS demonstration product will be developed in four stages. Focal

points will be overall system look and feel, integration of key databases, execution of WIDA models, and demonstration of value added.

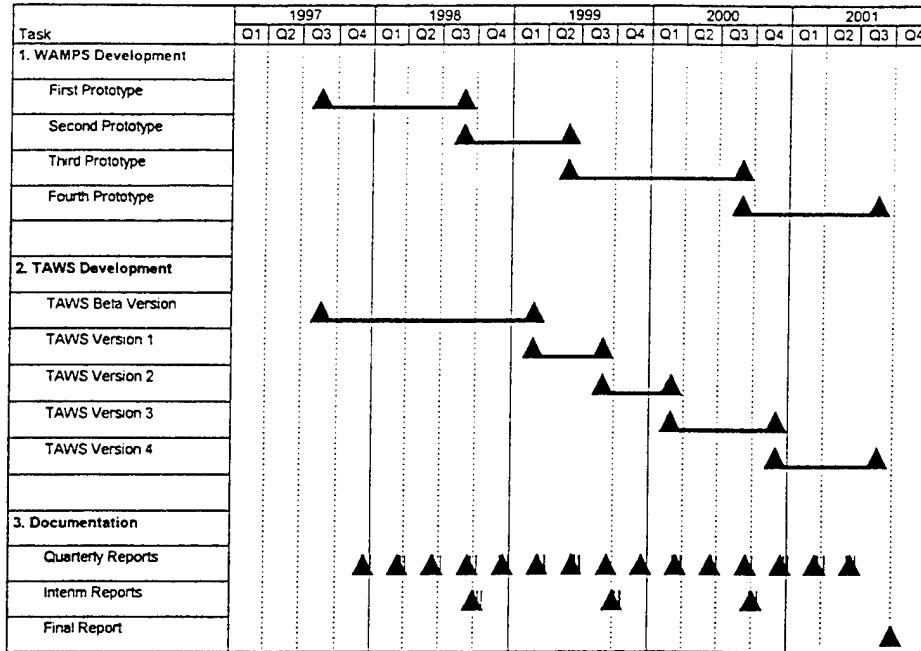

Figure 1. WIDA Project Schedule.

### 1.1.2 Task 2: Target Acquisition Weather Software (TAWS)

Target Acquisition Weather Software (TAWS) is being developed to replace the EO Tactical Decision Aid (EOTDA), integrating recent modeling and hardware/software technology improvements. TAWS will incorporate a modular system design, a Graphical User Interface (GUI) that maximizes usability, enhanced output products that can be tailored to users' specific needs, state-of-the-art physical models, automated weather data ingest, access to geographic databases, customized targets and sensors, and a target scene visualization capability. TAWS is being developed in five stages to achieve incremental, user-oriented development.

### 1.1.3 Task 3: Documentation

This task includes all project documentation. The following are planned as part of this contract:

- Quarterly status reports
- Annual progress reports

- Periodic briefings
- User's manuals to accompany each version of TAWS
- Final technical report

## **1.2 PROGRESS SUMMARY**

This report is the first Interim Report for Contract Number F19628-97-C-0087. This report covers the first year of the WIDA program, from 22 August 1997 through 31 August 1998.

## **1.3 REPORT ORGANIZATION**

This report contains five main sections. Section 2 describes the progress made on Task 1, WAMPS. Section 3 describes the progress made on Task 2, TAWS. Section 4 describes the progress made on Task 3, Documentation. Finally, Section 5 discusses plans in each of these task areas for the upcoming year.

## **2 TASK 1: WEATHER AUTOMATED MISSION PLANNING SOFTWARE (WAMPS)**

The purpose of this task is to develop demonstratable prototypes of a Weather Automated Mission Planning Software (WAMPS) system. The prototypes are intended to show how WIDAs, when integrated in automated mission planning systems, can support and improve the mission planning process. The WAMPS prototypes are being developed in four stages. Focal points are identification of appropriate mission planning systems, overall system look and feel, integration of key databases, execution of WIDA models, and demonstration of value added.

This task includes work in three areas: requirements analysis, development of WAMPS software prototypes, and demonstration of value added to the mission planning process. Work in each of these areas during the first year of the project is described below.

### **2.1 REQUIREMENTS ANALYSIS**

Requirements analysis was the primary focus of our efforts on WAMPS during the first year of the project. We interacted with AFRL Hanscom, AFRL Rome, and Air Combat Command (ACC) in order to help establish requirements. We continued to improve our depth of understanding of the mission planning process. We analyzed design documents and specifications for current and evolving mission planning systems, focusing in particular on the Theater Battle Management Core Systems (TBMCS). We pursued opportunities to observe all phases of the mission planning process during training exercises such as Blue Flag. We worked with AFRL to develop a set of WAMPS requirements as a result of these activities. These requirements are now being used in the development of the initial prototype.

A project kickoff meeting with AFRL was held at TASC on 16 September 1997 and included discussion of the initial WAMPS requirements. Discussion centered on the focus of the WAMPS prototype, stressing the importance of the look and feel of a mission planning system with sample data and weather effects, but without the interfaces to actual weather data or effects models. A decision was made to meet at ACC to obtain feedback from actual mission planners and from the potential user community.

A meeting was held at ACC on 16 October 1997 that included discussions on the WAMPS prototype. Several mission planning systems were noted as candidates for the look and feel of the WAMPS prototype. The Advanced Planning System (APS), the Force Level Execution System (FLEX), and DARPA's Joint Force Air Component Commander (JFACC) system were all covered. Additionally, exercises such as Blue Flag and Joint Task Force Exercise (JTFX) were mentioned as being potentially useful to observe to see mission planning systems in use.

Following the meetings, we contacted Bob Farrell at AFRL Rome to further discuss requirements and evaluate candidate programs to emulate. We began to evaluate where in the mission planning process weather, and specifically WIDAs, could be fit in with a WAMPS prototype. The Air Tasking Order (ATO) generation process where aircraft, weapons systems, and targets are matched seemed the best candidate. We obtained information about FLEX and APS, in preparation for scheduling demonstrations of these systems.

We traveled to AFRL Rome on 13 January 1998 to see demonstrations of APS and FLEX. In conjunction with AFRL, we determined that the step in the mission planning process that monitors and re-plans tasked missions (as required by weather, losses, combat events, cancellations, etc.) would be the most useful step in which to initially show value added by WIDAs. This step is handled by the Computer Assisted Force Management System (CAFMS) in the current Contingency Theater Automated Planning System (CTAPS) and will be handled by FLEX in the TBMCS. Also in conjunction with AFRL, we determined that WAMPS should emulate the look and feel of the future system TBMCS, as opposed to the current system CTAPS. TBMCS is scheduled for deployment in late 1998. We recommended to AFRL that the WAMPS prototype be interactive, run in a Web Browser, and be accessed either from a Web Server via the Internet or from local disk on a portable system. These recommendations were accepted.

Based on these decisions, we prepared a requirements specification document for WAMPS. This requirements document focuses on two components of WAMPS: 1) the demonstration of value added by exploiting weather information during the mission planning process and 2) the demonstration of how this added value can be achieved in the context of the mission planning process. We briefed the WAMPS Requirements Document to AFRL on 21 May 1998. AFRL accepted the concepts presented, and this became the planning specification for the WAMPS prototypes. A copy is presented in Appendix A.

We learned from AFRL that the January 1998 JTFX did not have an Air Force component. Later, plans to instead attend the May 1998 session were also derailed when the exercise was cancelled. We also learned that there were difficulties in registering for the February 1998 Blue Flag exercise. Instead, we attended a CTAPS operator/technician course at Hurlburt AFB, FL, in April 1998. This course allowed us to understand more completely the mission planning and ATO generation process.

## **2.2 PROTOTYPES**

No prototypes were completed during during the first year of the project. During the period June – August 1998, scenarios for the WAMPS prototype were discussed and developed, and the initial PowerPoint briefing slides that would constitute the first prototype were initiated. The slides were Web-based, with self-briefing formats. With AFRL approval, WAMPS activity was decreased in order to apply more effort to the initial TAWS software development.

## **2.3 DEMONSTRATION OF VALUE ADDED BY WAMPS TO THE MISSION, PLANNING PROCESS**

There was no activity in this area during during the first year of the project, other than that associated with developing the requirements in the Requirements Document.

### **3 TASK 2: TARGET ACQUISITION WEATHER SOFTWARE (TAWS)**

The purpose of this task is to develop Target Acquisition Weather Software (TAWS) to replace the DOS-based EO Tactical Decision Aid (EOTDA), taking advantage of modeling and hardware/software technology improvements. TAWS is intended to support the mission execution process. Eventually, TAWS may be used as a baseline system to integrate into the mission planning process, perhaps providing the technology to feed the WAMPS environment described above. TAWS is being developed in five stages to achieve incremental, user-oriented development.

This task includes work in nine areas: development of the TAWS system architecture, development of a GUI, design and development of TAWS output products, upgrades to the TAWS physical models, implementation of automated weather access, incorporation of improved geographic data, development of customized sensors, development of customized targets, and implementation of target scene visualization. Work in each of these areas during the first year of the project is described below. Work in the areas of Navy and Army requirements is also described.

#### **3.1 TAWS SYSTEM ARCHITECTURE**

Development of the TAWS system architecture was the primary focus of our efforts on TAWS during the first six months of the project. TAWS incorporates a modular system design in an object-oriented environment. We worked with AFRL to specify the TAWS system requirements. We incorporated these requirements into a concept of operations document, which included a functional decomposition, a data flow description, and a user-oriented process flow description. We then developed the object-oriented design of the TAWS core code. The design documents are now being used in the development of the TAWS Graphical User Interface (GUI).

A project kickoff meeting with AFRL was held at TASC on 16 September 1997 and included discussion of the TAWS architecture. The overarching concept was to leverage work previously done in the Night Vision Goggles Operations Weather Software (NOWS) to a similar architecture for TAWS. A meeting with users was held at HQ Air Combat Command (ACC) on 16 October 1997, and this concept was solidified.

Following the meetings, we put together a Concept of Operations (CONOPS) for TAWS. The CONOPS describes the functional components of the TAWS system, the user interface flow, the data flow, and the high-level software design. The CONOPS was presented to AFRL on 8 December 1997. Based on feedback received at AFRL, we updated the CONOPS and presented it to AFRL and the Naval Research Laboratory (NRL) on 6 January 1998. The revised CONOPS is included in Appendix B.

In conjunction with the CONOPS, we developed a diagram depicting the overall TAWS system architecture concept. This is shown in Figure 2. The concept shows the TAWS core code, or TAWS GUI, controlling a series of physical models and a series of modular processes. This process flow concept is detailed in Figure 3. The TAWS core code accesses external databases when necessary and creates/accesses internal databases when necessary. This data flow concept is detailed in Figure 4. The intent is to add new processes or data sources to the overall TAWS system architecture as they become available for each version.

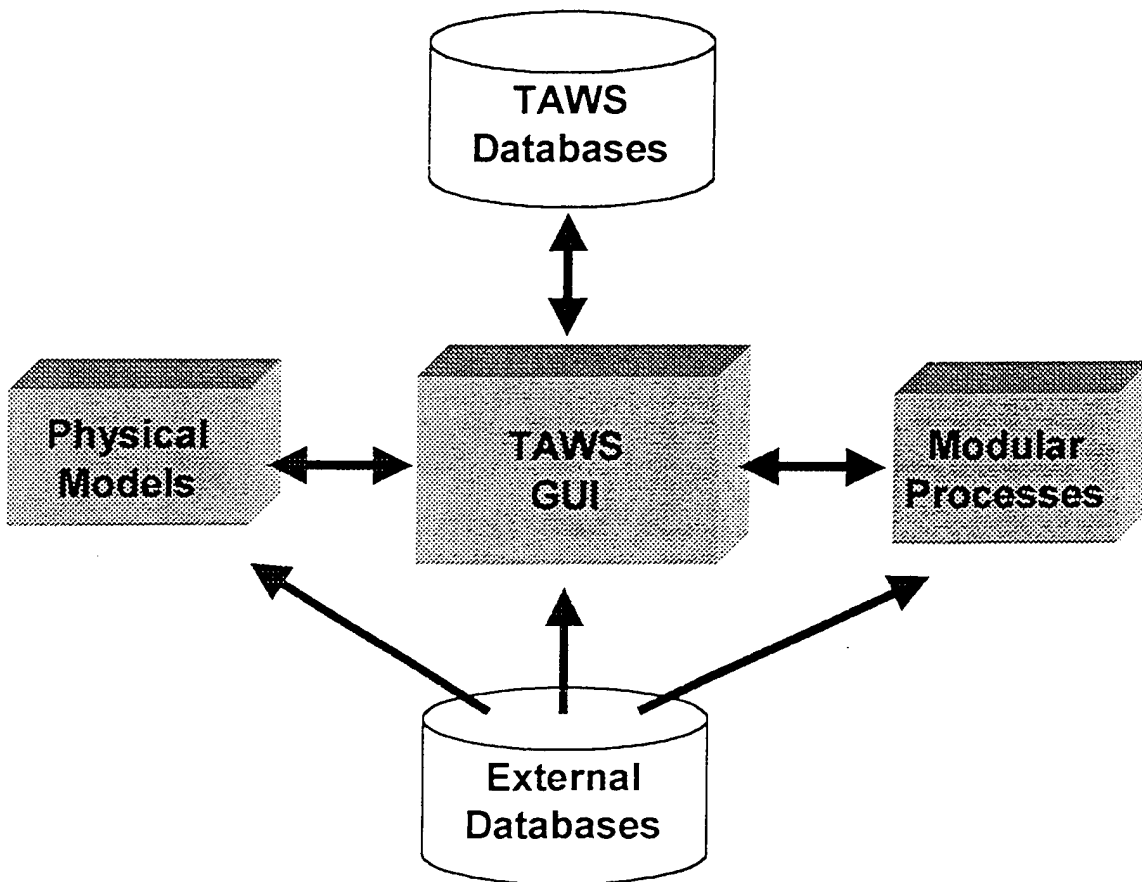

Figure 2. TAWS Architecture Concept.

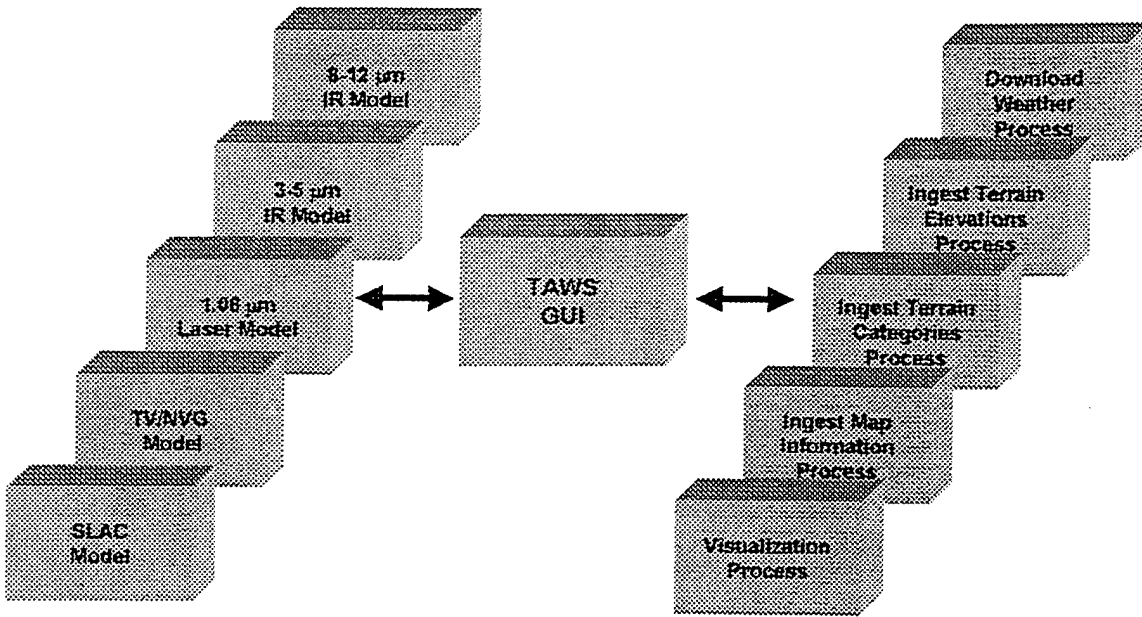

Figure 3. TAWS Process Flow Concept.

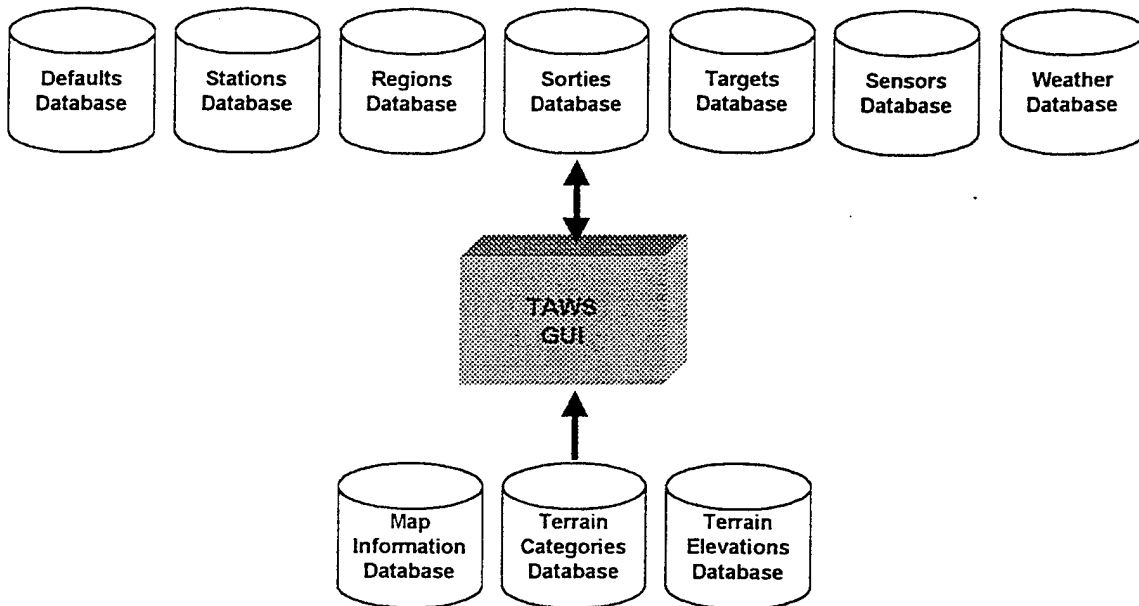
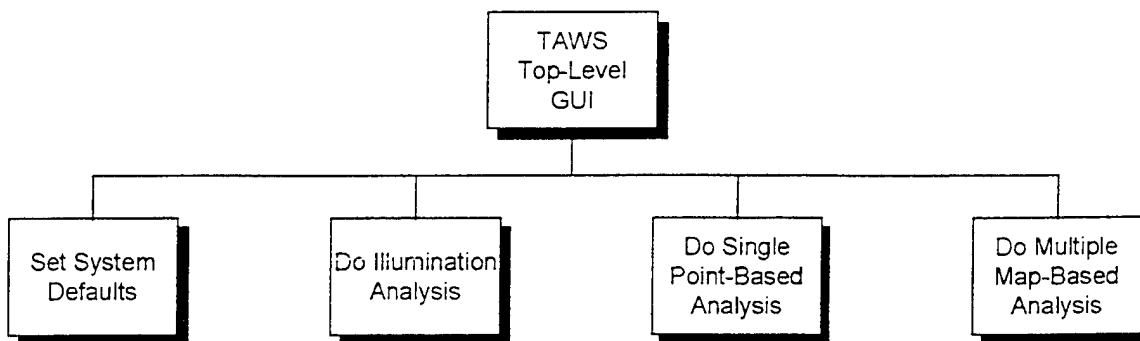

Figure 4. TAWS Data Flow Concept.

Following the CONOPS and the overall TAWS system architecture concept, we developed an object-oriented design for the TAWS core code. We presented this design to AFRL on 2 February 1998. The plan was to use the same underlying design for TAWS and NOWS, reusing as many of the core objects as possible and keeping the codes in co-development. AFRL approved the object-oriented design, and implementation began.

### 3.2 TAWS GRAPHICAL USER INTERFACE (GUI)

Development of the TAWS GUI was the primary focus of our efforts during the second six months of the project. The TAWS GUI used the NOWS GUI as a starting point, and was modified for TAWS-specific requirements. Look-and-feel changes were also made based on NOWS user feedback. A representation of the high-level TAWS GUI design is shown in Figure 5.



**Figure 5. TAWS GUI Concept.**

Although the initial plan called for development of the TAWS GUI in the Galaxy environment, Visix, the company that developed the GALAXY cross-platform development environment used for the NOWS GUI, went out of business in March 1998. We evaluated several options for the continued development of the TAWS GUI and presented our findings to AFRL on 9 April 1998. We recommended to AFRL that we transition NOWS to Microsoft Visual C++, and develop the TAWS GUI entirely in Visual C++. The advantages of this approach were many: better support for Windows 95/NT and future versions of Windows; easy access to standard GUI controls such as buttons, menus, wizards, tabs, dialog boxes, etc.; ability to adopt a standard Microsoft product look-and-feel; and better code maintainability. AFRL concurred, and we began to implement the object-oriented design in Visual C++. Two samples from the TAWS GUI are shown in Figure 6.

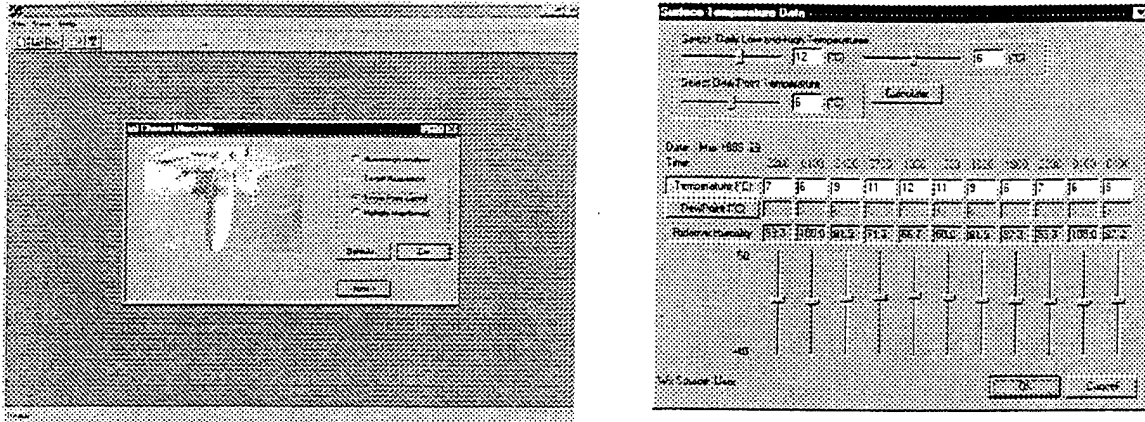

Figure 6. Samples of the TAWS GUI.

We began to assemble a prototype of the TAWS GUI and to prepare for a preliminary TAWS Beta Version design review.

### 3.3 TAWS OUTPUT PRODUCTS

There was no work in this area during the first year of the project.

### 3.4 PHYSICAL MODELS

The TAWS physical models (3-5  $\mu\text{m}$  and 8-12  $\mu\text{m}$  infrared, 1.06  $\mu\text{m}$  laser, and television/NVG) were ported from the DOS-based Microsoft FORTRAN compiler used for the EOTDA Version 3.1 to the Digital Visual FORTRAN compiler. The new compiler identified several problems associated with the IR model, and these problems were corrected. Testing verified that results with the newly-compiled code were consistent with EOTDA results. The plan for TAWS Beta is not to change the physics of the models, but to port the EOTDA 3.1 models, with the 3-5  $\mu\text{m}$  upgrade, to the new TAWS environment.

### 3.5 AUTOMATED WEATHER

A series of communications brought forth the requirement for an early version of TAWS to include a connection to the Air Force Weather Agency (AFWA) to receive automated weather as a form of initializing the TAWS defaults. Initial contact was made

with AFWA, and work began to definitize the type of connection, security requirements, and other details of the format.

### **3.6 GEOGRAPHIC DATABASES**

There was no work in this area during the first year of the project. The decision was made for the TAWS Beta Version to use the same geographic databases as NOWS: the National Imagery and Mapping Agency's (NIMA's) Vector Smart Map Level 0 for mapping data and the DeFries and Townshend Land Cover Classification Map (1994a) for default background information for a user-specified target location.

### **3.7 CUSTOMIZED SENSORS**

There was no work in this area during the first year of the project.

### **3.8 CUSTOMIZED TARGETS**

There was no work in this area during the first year of the project.

### **3.9 VISUALIZATION**

TASC investigated a variety of options for the visualization component of TAWS. A meeting at AFRL on 22 December 1997 covered the details of the Infrared Target Scene Simulation (IRTSS) software. Since components of IRTSS are scheduled to be integrated into TAWS, it was decided to use IRTSS methodologies in TAWS as much as possible to reduce code development. Because IRTSS uses OpenGL for target scene visualization, and OpenGL drivers are available for the Windows 95/NT platforms, it was decided to use OpenGL for the TAWS visualization component. TASC developed a rudimentary visualization capability focusing on the visualization of inherent target radiance for the visible wavelength region. TASC developed the necessary OpenGL application interfaces, built OpenGL utility libraries for use with Windows 95/NT, developed code to access the 3-D target geometry files, implemented code to construct a target wire-frame drawing, added controls for viewpoint manipulation, implemented rendering of high-resolution, device-independent bitmap imagery, and incorporated gray-scale shading based on TV model inherent target radiance results. The code developed should be extendable to IR model inherent temperature results.

### **3.10 ARMY AND NAVY INCLUSION INTO TAWS**

A contract engineering change proposal (ECP) was negotiated to add Navy requirements to the TAWS effort. This change included the following major components:

- Incorporate Navy targets and sensors
- Incorporate automated weather download from Navy sources
- Incorporate Navy model improvements

Additionally, talks were started with Army representatives to show how Army inclusion into the TAWS program at this point could benefit Army operators and leverage current work being done by Air Force and Navy. Initial discussions have been very positive.

## **4 TASK 3: DOCUMENTATION**

The purpose of this task is to provide periodic project progress reports, periodic briefings, and software documentation. Progress made in these areas during the first year of the project is described below.

### **4.1 QUARTERLY PROGRESS REPORTS**

Quarterly progress reports were submitted to AFRL on 23 December 1997, 13 March 1998, 15 June 1998, and 15 September 1998, providing technical and financial summaries of work completed during the first year of the project.

### **4.2 PERIODIC BRIEFINGS**

Periodic briefings were given to describe project status and to review system designs. A project kickoff meeting with AFRL was held at TASC on 16 September 1997. A project kickoff meeting was held at ACC on 16 October 1997.

We briefed the WAMPS Requirements Document to AFRL on 21 May 1998.

Briefings on TAWS were conducted periodically with AFRL. The TAWS Concept of Operations was presented to AFRL on 8 December 1997; a modified CONOPS was presented to AFRL and NRL on 6 January 1998. The object-oriented design for the TAWS core code was presented to AFRL on 2 February 1998. We presented options for the development of the TAWS GUI to AFRL on 9 April 1998.

On 24-25 March 1998, TAWS and WAMPS briefings were presented at the annual WIDA Conference at Langley AFB, VA.

A TAWS briefing was presented to the US Army DAMO/FDI on 12 August 1998.

### **4.3 SOFTWARE DOCUMENTATION**

TASC established a documentation process to together the various elements of the TAWS GUI. Developmental use cases were compiled for each of the TAWS processes. Each of these documents provides an operational description of the component process,

describes the dialogs or user input screens which must be written to support the component, and itemizes which objects (or classes) the component must access. The documents will be used in the further development of the TAWS GUI, and to make sure that all requirements are met.

## **5 PLANS FOR NEXT YEAR**

Plans for next year include the following:

- Completion of the first and second WAMPS Prototypes
- Release of TAWS Beta and TAWS Version 1
- Addition of Navy requirements to TAWS
- Addition of Army requirements to TAWS

## REFERENCES

1. DeFries, R.S., and J.R.G. Townshend, 1994a: "NDVI-Derived Land Cover Classification at Global Scales," *International Journal of Remote Sensing*, 15:3567-3586. Special Issue on Global Data Sets.

## **APPENDIX A**

### **WEATHER AUTOMATED MISSION PLANNING SOFTWARE (WAMPS)**

#### **DEMONSTRATION PROTOTYPE**

#### **REQUIREMENTS DEFINITION**

### **1 SCOPE**

#### **1.1 IDENTIFICATION**

This document establishes requirements for the Weather Automated Mission Planning Software (WAMPS) demonstration prototype.

#### **1.2 PURPOSE**

The purpose of the WAMPS demonstration prototype is to impress upon the mission planning community and warfighting policy-makers how weather, and specifically Weather Impact Decision Aids (WIDAs), can benefit the mission planning process. The prototype will demonstrate how we can use weather and WIDAs as force multipliers in automated mission planning systems by facilitating the effective use of Electro-Optical weapon systems against enemy targets.

### 1.3 BACKGROUND

In the modern warfighter era, where we may fly thousands of sorties over a very short period of time, we rely on automation to plan, execute and re-plan missions quickly enough so that enemy forces are absolutely overwhelmed with our military superiority. Although weather plays a critical role in the success or failure of many missions, we have not integrated weather into the automated planning process. As a result, missions that could have been successful do not succeed because we do not properly consider weather impacts when we plan the missions.

There is significant value in exploiting weather information and WIDAs across the full spectrum of mission planning and execution. During the long range mission planning process, weather is used to select targets, weapons systems, and broad tactics. As the Air Tasking Order (ATO) is generated, weather and WIDA impacts on weapons system performance could be used to refine time-over-target schedules, battle tactics, and weapons system allocations. During the execution phase, mission monitoring, aborts, battle damage assessments (BDA), and re-planning are all weather and WIDA - dependent.

A significant impact to full integration of weather and WIDA has been the laborious, manpower-intensive process for applying weather information. With the automation of many meteorological functions, including determination of weather impacts, these data can be integrated with the advances in automation of mission planning and execution functions. For the Air Force, the future Theater Battle Management Core Systems (TBMCS) automated mission planning systems, specifically Theater Air Planning (TAP) for ATO generation and Force Level Execution (FLEX) system for mission monitoring and re-planning are ideal candidates for the inclusion of automated weather and WIDA tools.

Specific weather phenomena affect specific weapons systems. For example, :

- Haze and/or fog can prevent a successful lock-on for television guided weapons.
- Infrared sensors, operating at 3-5 um or 8-12 um are seriously degraded by high values of absolute humidity.
- Laser guided munitions have their designator beam attenuated by aerosols along the beam path.

The WIDAs have been developed to assist mission planners in the selection and use of these various precision weapons systems.

One such WIDA is the Electro-Optical Tactical Decision Aid (EOTDA). This software model predicts the performance of air-to-ground weapon systems and direct view optics based on environmental and tactical information. The environmental information includes weather forecast information. The EOTDA expresses performance in terms of maximum detection or lock-on range. Typically, mission failure may occur if a weapon is not able to achieve lock-on outside of some minimum lock-on range. Therefore, EOTDA generated lock-on range predictions, based on quality weather forecasts, and compared with mission effectiveness criteria, can help predict potential mission failure or success due to weather factors. Automated mission planning systems can then alert mission planners at their consoles, and provide guidance during re-planning, to maximize the number of successful missions and minimize costly aborts over target.

For example, consider a mission which, due to tactical constraints, will only be successful if an IR weapon can lock-on to the target outside of 4 km. Also consider the weather forecast, valid for the time over target and target location. By using automated WIDAs, we will be able to predict a lock on range or zone. If the predicted zone is 7-10 km then the mission is predicted to be successful. If the predicted zone is 1-2 km then the mission is predicted to be unsuccessful. If the predicted zone is 3-5 km then the mission may or may not be successful. Mission planners would receive automatic alerts in the latter two results.

Much of the information required by the EOTDA is already available in automated mission planning systems. The remaining information, including weather information, can also be made available, so that automated mission planning systems may execute EOTDAs, compare the results with mission effectiveness criteria, and predict potential mission failure due to weather for each planned or re-planned mission.

#### **1.4 APPROACH**

With effective content, evolution, and distribution, the WAMPS demonstration prototype will show how weather and WIDAs, specifically the EOTDA, can benefit the mission planning process. In addition to demonstrating integration of WIDA into the mission planning process, the program will illustrate, in a quantitative sense, the value-added of this critical information.

The program will evolve through four distinct phases, each one showing both planning aspects and value-added aspects. The four phases, broadly described, are as follows:

- **Phase 1:** A user-controlled slide show that illustrates a representative graphical user interface (GUI). The user is intended to be anyone who interacts with the GUI, and can include AFRL, mission planners, TASC, or other appropriate persons. Scenario data is predetermined to highlight the capability of WAMPS.
- **Phase 2:** The predetermined scenarios are expanded to increase the number of missions, and will allow interactive functionality. Actual EOTDA computations will be made, alerts provided to mission planners, and illustration made of the ability to influence mission planning and the ATO through WAMPS.
- **Phase 3:** Adds the ability to mimic mission monitoring and replanning.
- **Phase 4:** Incorporates new requirements based on feedback on previous phases.

The prototype shall evolve in response to feedback from the mission planning community and users who are exposed to the WAMPS prototype..

To ensure maximum exposure and subsequent feedback, the prototype shall be available via the Internet on the World Wide Web.

## 2 REQUIREMENTS

### 2.1 DESCRIPTION

The WAMPS demonstration prototype shall be a self-guided, interactive software system consisting of: 1) The WAMPS Planning Demo which will demonstrate how the specific addition of WIDA information can be achieved in the context of the mission planning process, and 2) The WAMPS Value Demo which will quantify the value of exploiting weather information during the mission planning process.

### 2.2 GENERAL REQUIREMENTS

- 2.2.1 The WAMPS prototype system shall be interactive, run in a web browser, and be hosted on a web server that can be accessed from the Internet.

- 2.2.2 The WAMPS prototype system shall also be hosted on a portable, stand-alone web server, to be demonstrated at locations without Internet access.
- 2.2.3 The WAMPS prototype system shall present introductory slides that describe the purpose of the prototype.
- 2.2.4 The WAMPS prototype system shall provide guiding textual narrative with each slide, as well as context-sensitive help screens.
- 2.2.5 The WAMPS prototype system shall be developed iteratively and delivered in four phases.
- 2.2.6 Each phase shall meet the requirements of all previous phases and shall be enhanced to incorporate new requirements, agreed upon by AFRL and TASC, based on feedback from users regarding previous phases.

### **2.3 WAMPS PLANNING DEMO REQUIREMENTS**

#### **2.3.1 WAMPS Planning Demo in Phase 1**

- 2.3.1.1 The WAMPS Planning Demo in Phase 1 shall be a user-controlled slide show that demonstrates a representative GUI for interacting with the WAMPS.
- 2.3.1.2 The WAMPS Planning Demo in Phase 1 shall present a series of slides that mimic the functions of planning, monitoring, and re-planning a single mission (i.e., the marquee of mission monitoring time lines and re-planning dialog panels). Anticipating the USAF migration into the TBMCS era, this slide show will use the TAP and FLEX marquees to illustrate how WAMPS could benefit the mission planning process.
- 2.3.1.3 The WAMPS Planning Demo in Phase 1 shall present a slide that shows how a mission planner might enter mission effectiveness alert thresholds. This shall include the minimum acceptable lock-on range.
- 2.3.1.4 The WAMPS Planning Demo in Phase 1 shall present a slide that shows an alert on the mission monitoring time line, indicating that the effectiveness criteria fall below the internally stored thresholds due to mission-limiting weather conditions.
- 2.3.1.5 The WAMPS Planning Demo in Phase 1 shall present a slide that shows the mission re-planning dialog panels, augmented by the availability of new WAMPS decision support tools.

2.3.1.6 The WAMPS Planning Demo in Phase 1 shall present examples of the WAMPS decision support output products that graphically display windows of opportunity, wherein the mission effectiveness criteria are satisfied. These shall include the following:

- Time windows for selected sensors, azimuths, and altitudes
- Azimuth windows for selected sensors, times, and altitudes
- Altitude windows for selected sensors, times, and azimuths

2.3.1.7 The WAMPS Planning Demo in Phase 1 shall present a slide that indicates a change in alert status (e.g., remove the warning of potential mission failure from the screen) of the re-planned mission.

2.3.1.8 The WAMPS Planning Demo in Phase 1 shall solicit feedback from AFRL, mission planners, and other appropriate users in order to properly evolve the system.

### **2.3.2 WAMPS Planning Demo in Phase 2**

2.3.2.1 The WAMPS Planning Demo in Phase 2 shall focus on several pre-defined missions, agreed upon by AFRL and TASC, to demonstrate WAMPS for a variety of weather/target scenarios during the mission planning process

2.3.2.2 The WAMPS Planning Demo in Phase 2 shall present a series of slides that mimics the TAP function of weaponing to generate an ATO, augmented by the availability of new WAMPS decision support tools.

2.3.2.3 The WAMPS Planning Demo in Phase 2 shall be interactive, displaying changes in the mission alert status in response to user-selected mission effectiveness thresholds and user re-planned mission parameters (sensor, time, azimuth and altitude). The user shall be able to access the decision support output products, in which changes will also be displayed.

2.3.2.4 The WAMPS Planning Demo in Phase 2 shall look up these changes from a database of mission effectiveness results computed from a series of EOTDA runs which correspond to the weather/target scenarios. Results will exist for all possible mission effectiveness threshold/mission parameter combinations available to the user.

2.3.2.5 The WAMPS Planning Demo in Phase 2 shall solicit feedback.

### **2.3.3 WAMPS Planning Demo in Phase 3**

- 2.3.3.1 The WAMPS Planning Demo in Phase 3 shall mimic mission monitoring and re-planning functions of the mission planning process, operating on a test-bed version of the current mission planning database, which will be mocked up to contain canned data for several missions. It will carry forward the FLEX marquee demonstrated in Phase 1.
- 2.3.3.2 The test-bed database schema shall be expanded, as necessary, to include parameters needed to support computation of mission effectiveness.
- 2.3.3.3 There shall be a default set of active database parameters which, when altered, trigger re-computation of mission effectiveness results, and trigger alerts as necessary.
- 2.3.3.4 The initial default set of active database parameters shall be all those that can effect the resulting mission effectiveness. The user shall be able to override the default set of database parameters to be any subset of the initial default set.
- 2.3.3.5 Upon start-up, the WAMPS Planning Demo in Phase 3 shall make the necessary EOTDA runs and compute mission effectiveness results for all missions in the test-bed database, using the corresponding mission data.
- 2.3.3.6 The WAMPS Planning Demo in Phase 3 shall solicit feedback.

### **2.3.4 WAMPS Planning Demo in Phase 4**

- 2.3.4.1 The WAMPS Planning Demo in Phase 4 shall be enhanced to incorporate new requirements, agreed upon by AFRL and TASC, based on feedback on previous phases.

## **2.4 WAMPS VALUE DEMO REQUIREMENTS**

### **2.4.1 WAMPS Value Demo in Phase 1**

No activity in this phase.

### **2.4.2 WAMPS Value Demo in Phase 2**

- 2.4.2.1 The WAMPS Value Demo in Phase 2 shall be a user-controlled slide show, clearly illustrating in a quantitative manner the value-added of weather and

WIDA in the mission planning process. This will be implemented in limited fashion only for this phase.

2.4.2.2 Based on AFRL and user feedback, metrics may be tuned or further defined to best illustrate the value-added.

### **2.4.3 WAMPS Value Demo in Phase 3**

2.4.3.1 The WAMPS Value Demo shall consist of an interactive display engine and a database.

2.4.3.2 The database shall contain pre-computed values of previously agreed-upon metrics, which--independent of target, background, approach azimuth or altitude--reflect the impact of weather and WIDAs on mission effectiveness.

2.4.3.3 Metrics shall be computed for combinations of the following categories:

- **Mission effectiveness criterion**--a lock-on range threshold which, if realized, determines mission success
- **Weather category**--good, marginal, or poor overall weather environments
- **Sensor type**--one each chosen from IR, TV, or Laser

over a predefined ensemble of mission scenarios which vary with respect to a range of mission parameters. In general, successful scenarios shall occur when mission success is predicted and can be achieved under actual conditions, or when mission failure is predicted and occurs under actual conditions. Failed scenarios will occur when mission success is predicted but cannot be achieved under actual conditions, or when mission failure is predicted but mission succeeds under actual conditions.

2.4.3.4 The display GUI will allow the user to select various representations of the values to display.

### **2.4.4 WAMPS Value Demo in Phase 4**

2.4.4.1 The WAMPS Value Demo in Phase 4 shall be enhanced to incorporate new requirements, agreed upon by AFRL and TASC, based on feedback from previous phases.

**APPENDIX B**

**TARGET ACQUISITION WEATHER SOFTWARE  
(TAWS)**

**SYSTEM CONCEPT OF OPERATIONS**

## TAWS SYSTEM CONCEPT: Objectives

Functional flow

Key user decision points effecting flow

Key user inputs

Major input sources and where they are used

Major outputs and where they are produced







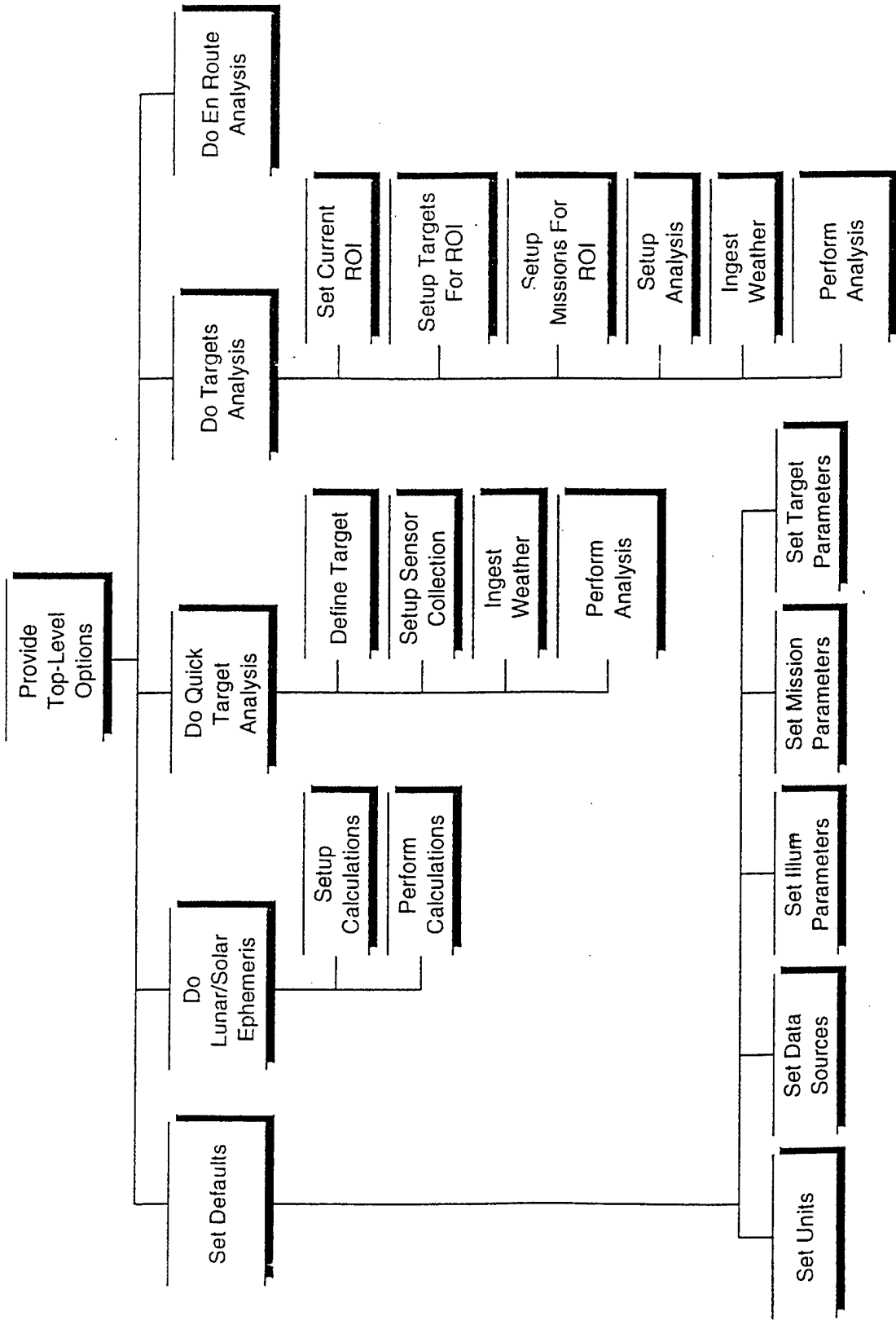



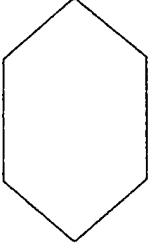
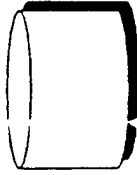

Interaction with the physical models

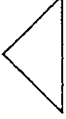
Differences between NOWS and TAWS

# TAWS SYSTEM CONCEPT: Functional Decomposition

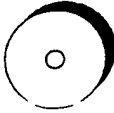

# TAWS SYSTEM CONCEPT: Symbols

SYSTEM ELEMENTS	FLOW SYMBOLS	FLOW MODIFIERS
 PROCEDURE	 PROCEDURAL FLOW	 CONSTRAINT
 HARD DISK	 INFORMATION FLOW	 USER DECISION POINT (fan out)
 MOUSE		 FAN IN
 MONITOR		 RETURN TO PREVIOUS
 KEYBOARD		 FLOW PATH LABEL
 CD ROM		 LOOP

# TAWS SYSTEM CONCEPT: Provide Top-Level Options

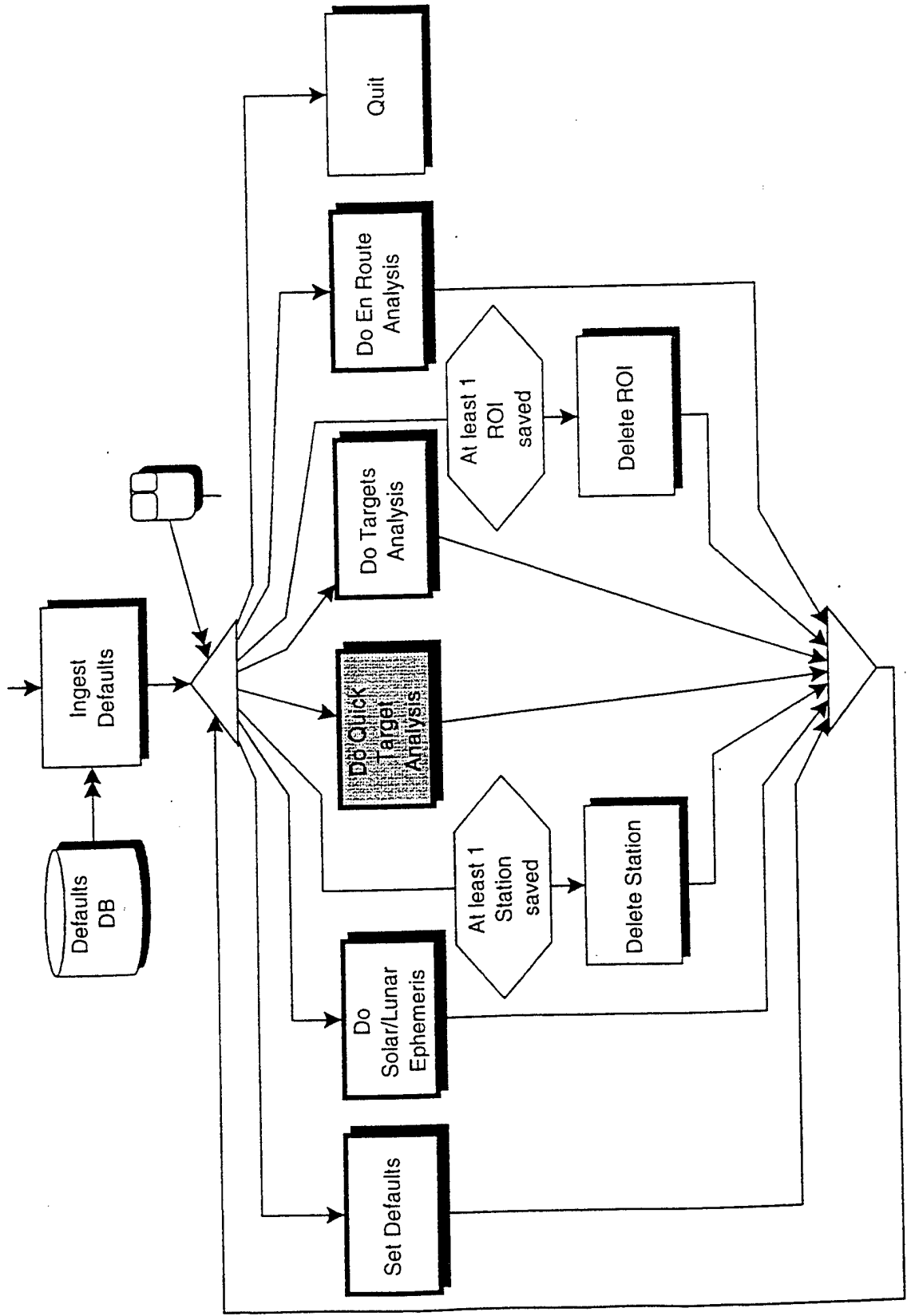

# TAWS SYSTEM CONCEPT: Set Defaults

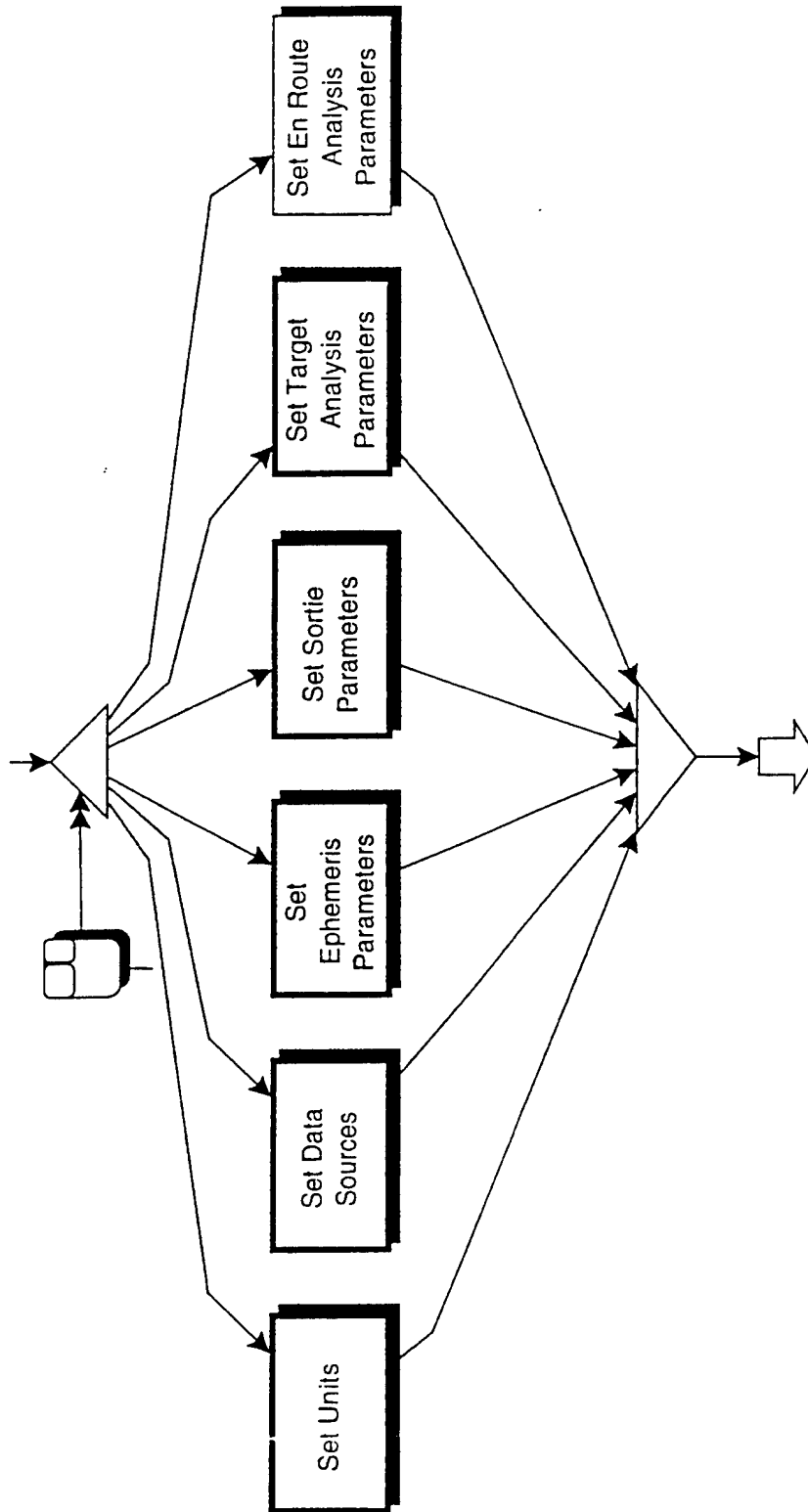

# TAWS SYSTEM CONCEPT: Set Defaults for [x]

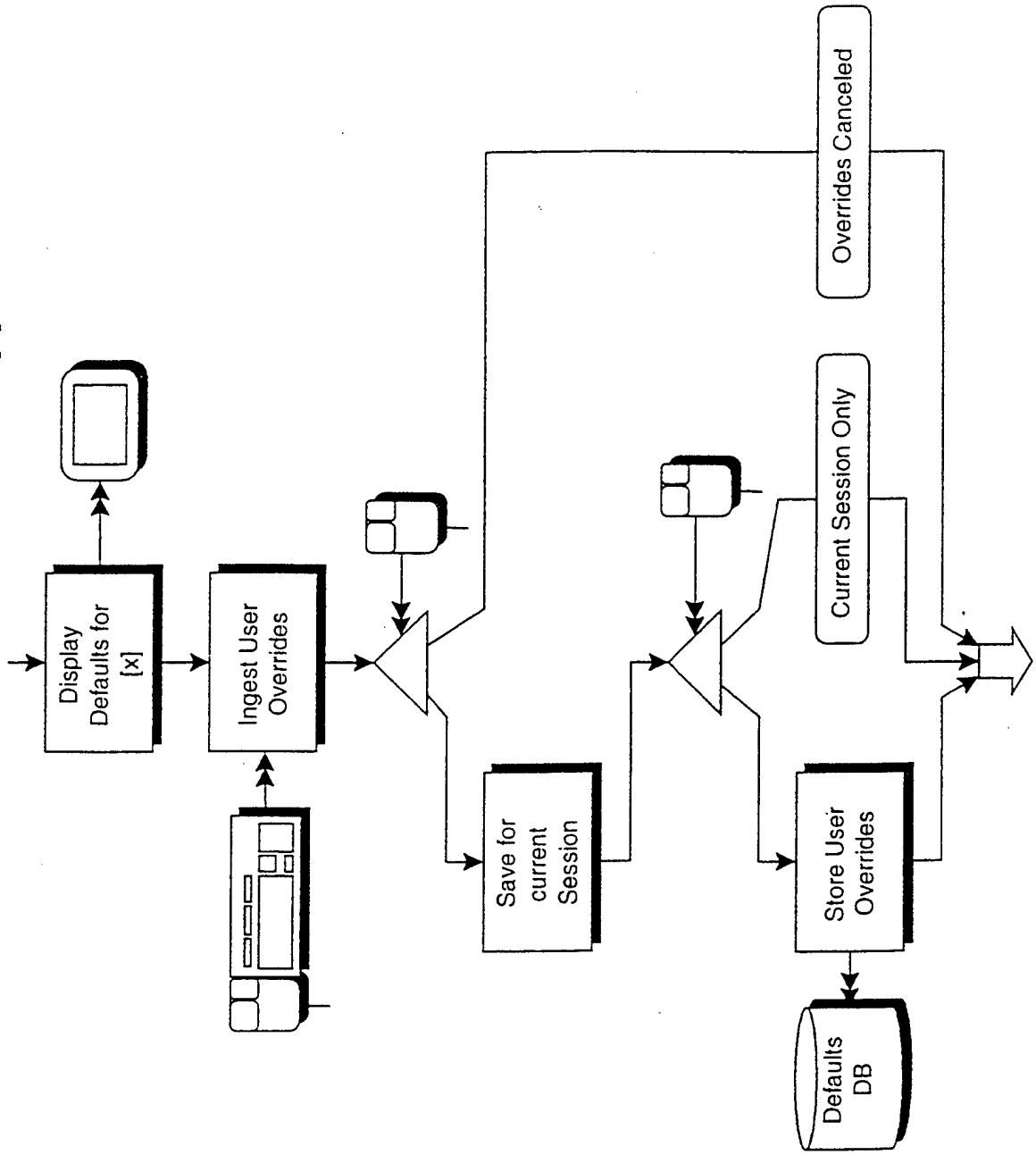

TAWS SYSTEM CONCEPT: Do Solar/Lunar Ephemeris

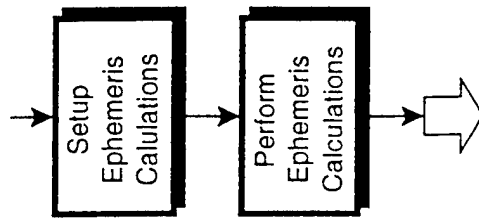

# TAWS SYSTEM CONCEPT: Setup Ephemeris Calculations

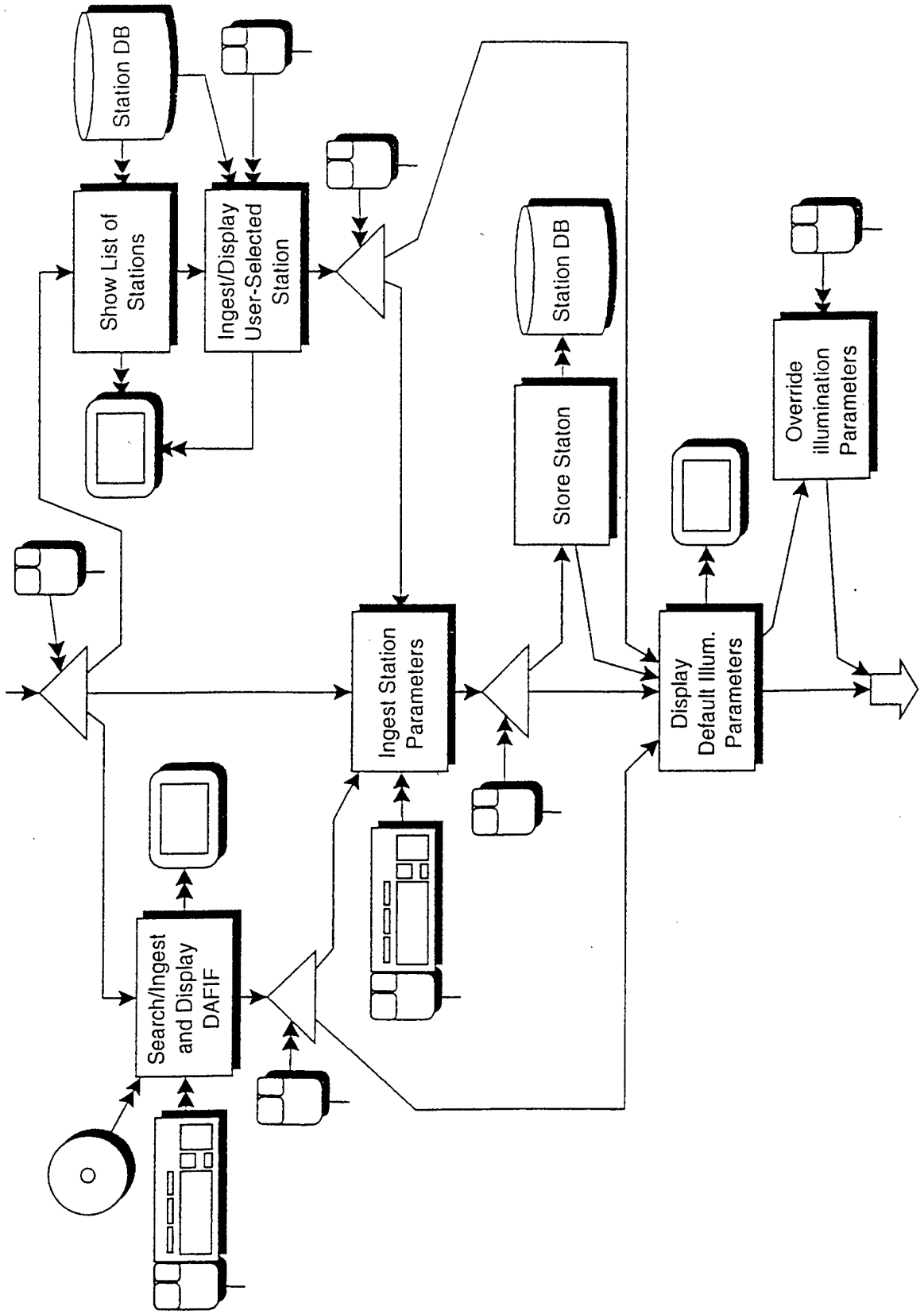

# TAWS SYSTEM CONCEPT: Perform Ephemeris Calculations

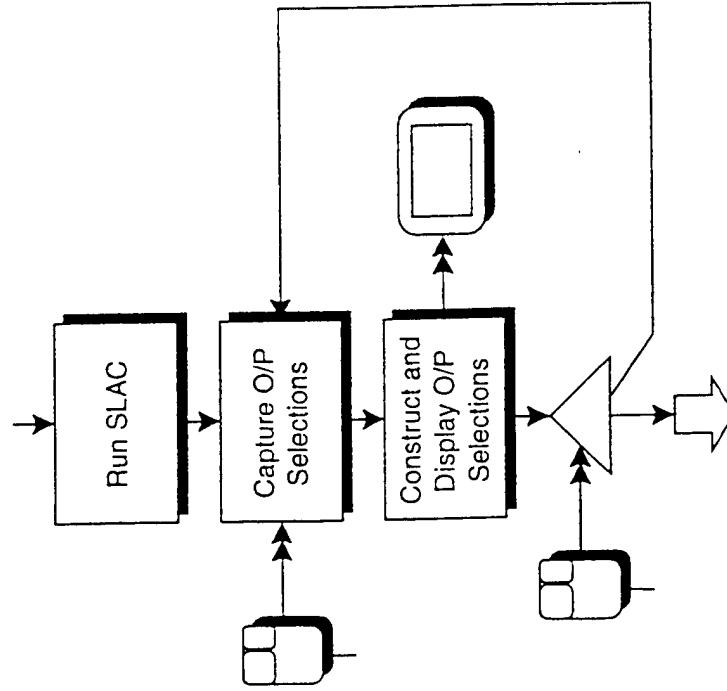

# TAWS SYSTEM CONCEPT: Do Quick Target Analysis

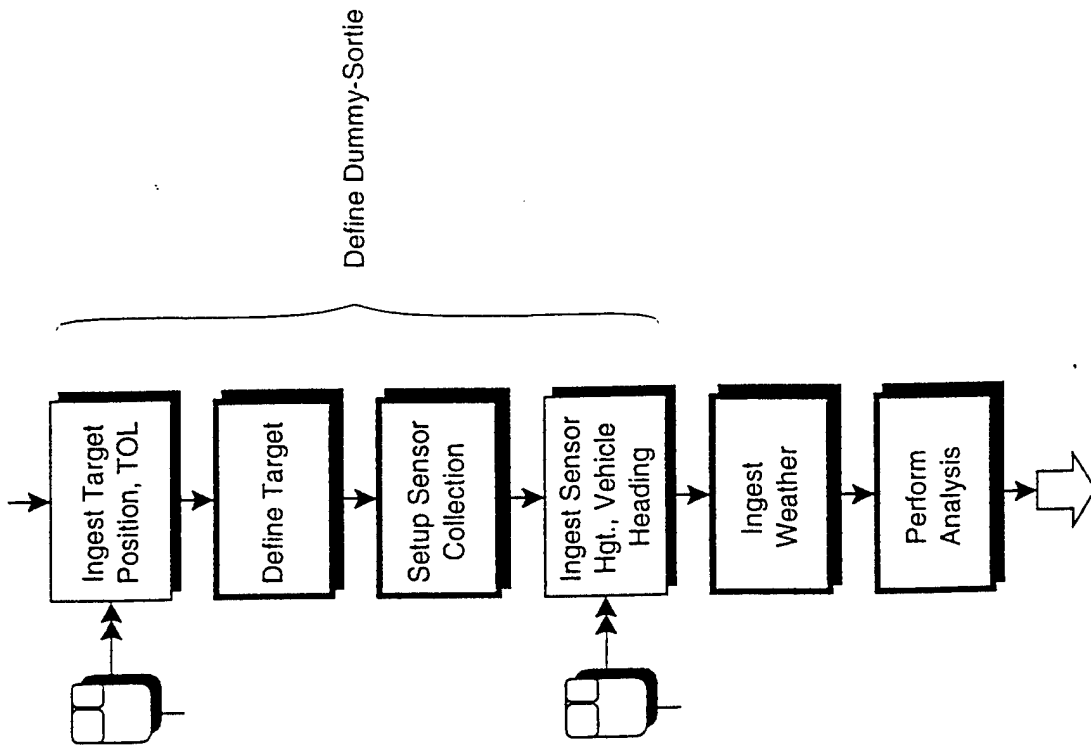

# TAWS SYSTEM CONCEPT: Define Target

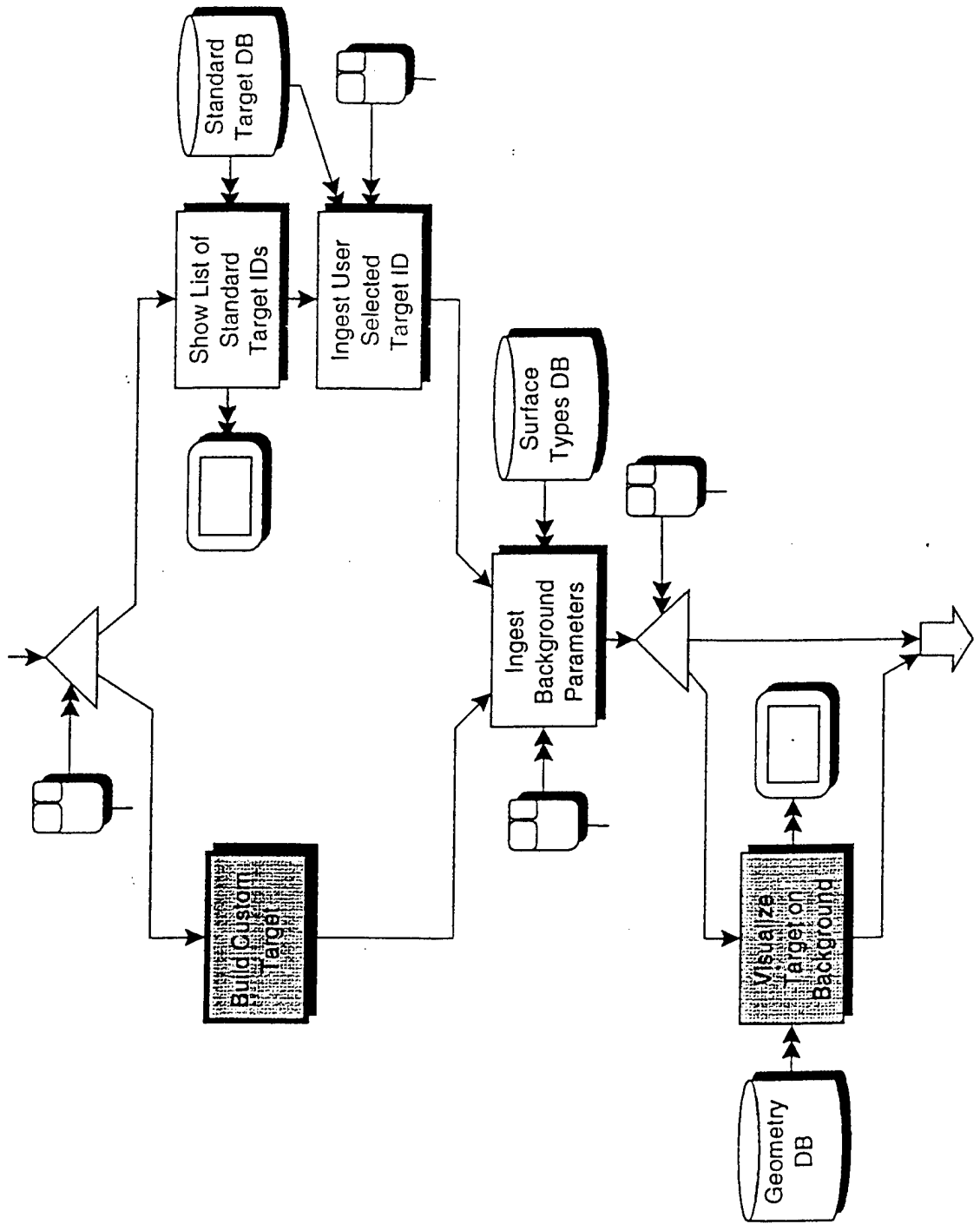

# TAWS SYSTEM CONCEPT: Build Custom Target

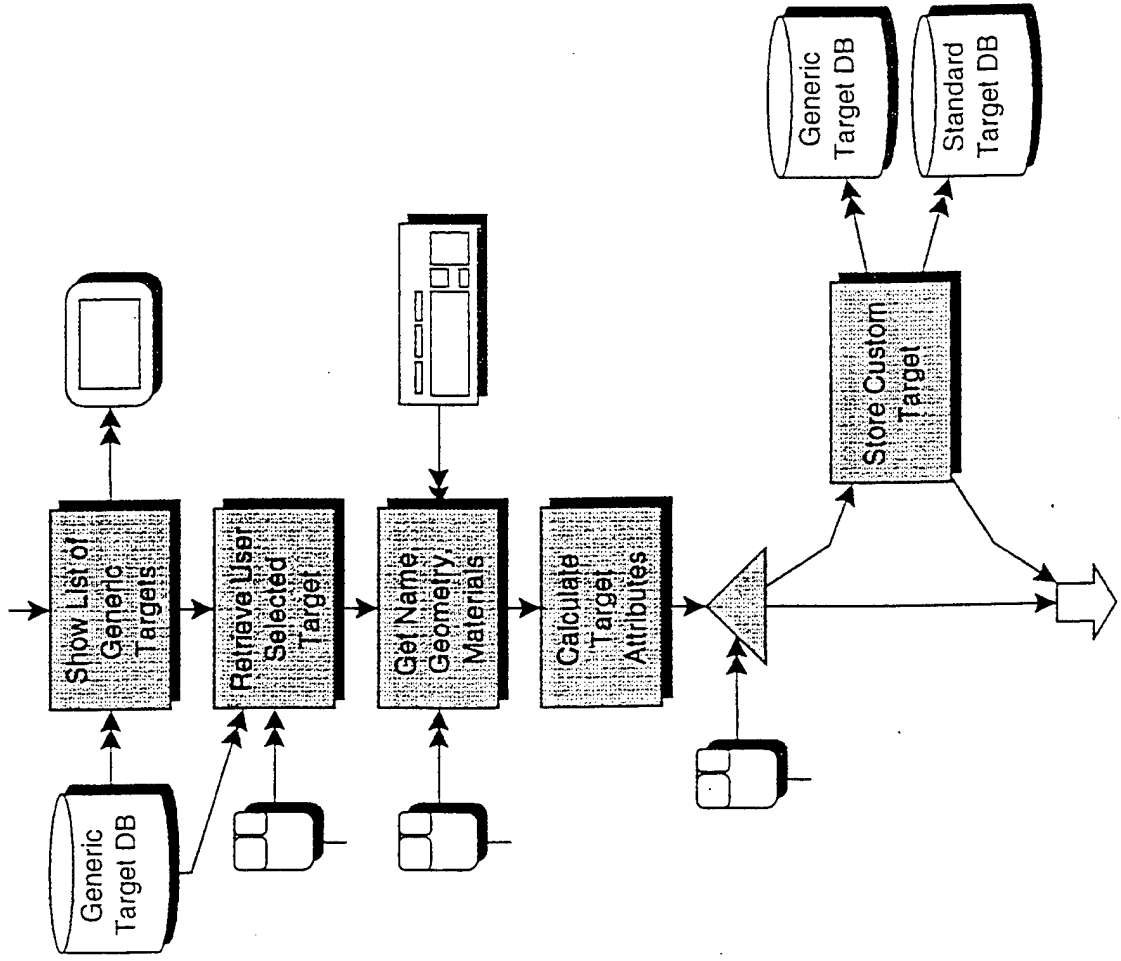

# TAWS SYSTEM CONCEPT: Setup Sensor Collection

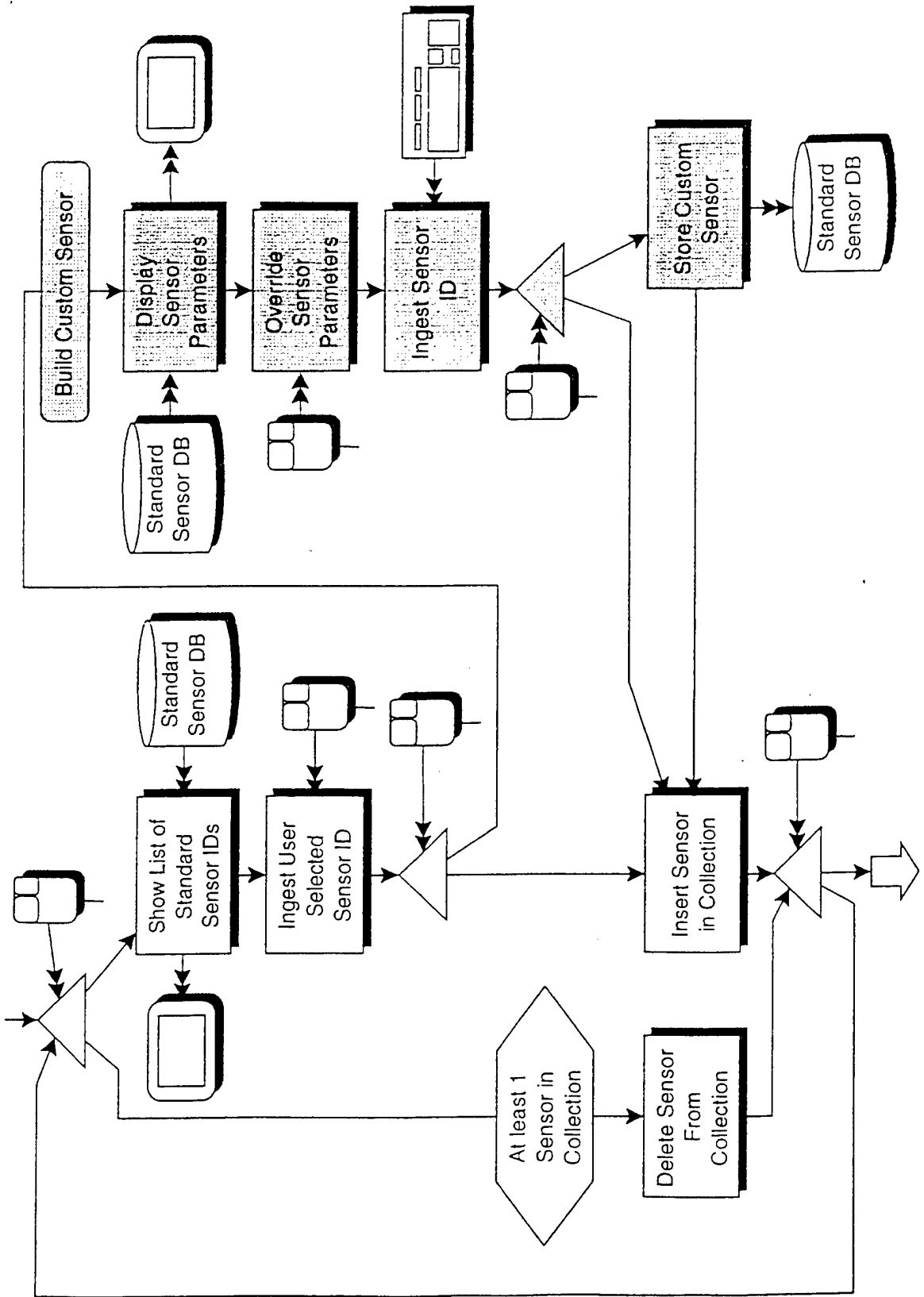

# TAWS SYSTEM CONCEPT: Ingest Weather

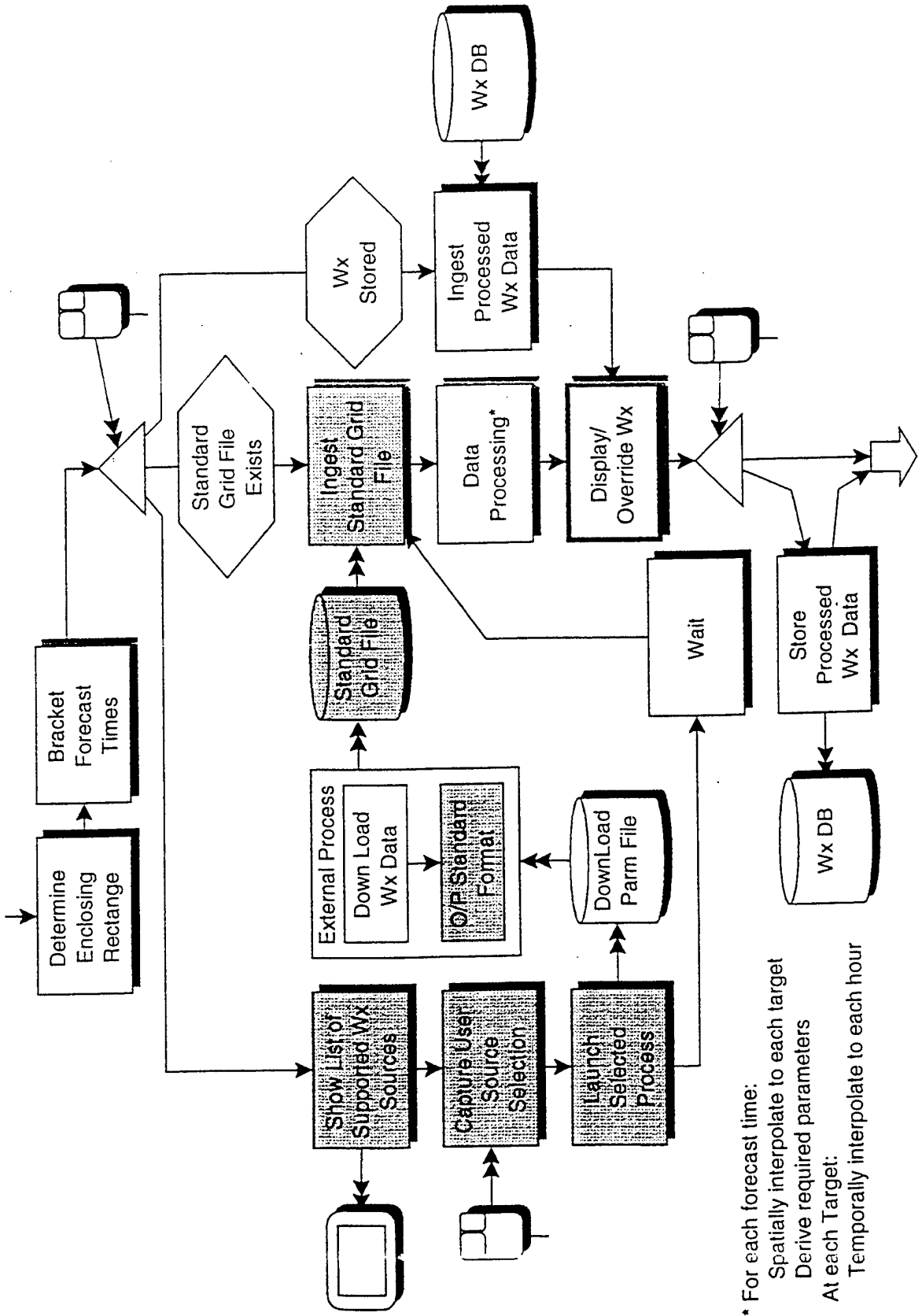

\* For each forecast time:  
 Spatially interpolate to each target  
 Derive required parameters  
 At each Target:  
 Temporally interpolate to each hour

TAWS SYSTEM CONCEPT: Display/Override Weather

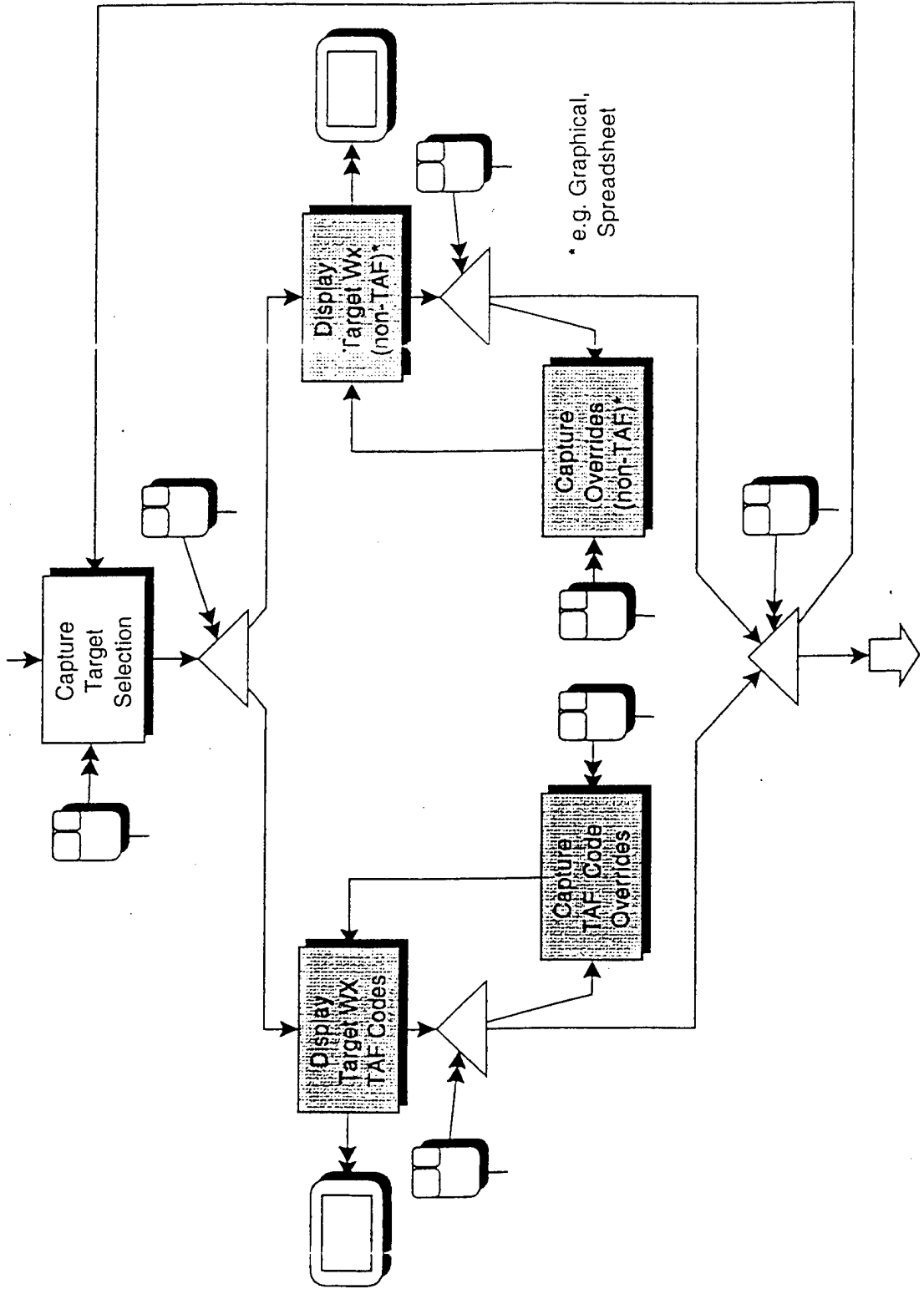

# TAWS SYSTEM CONCEPT: Perform Analysis

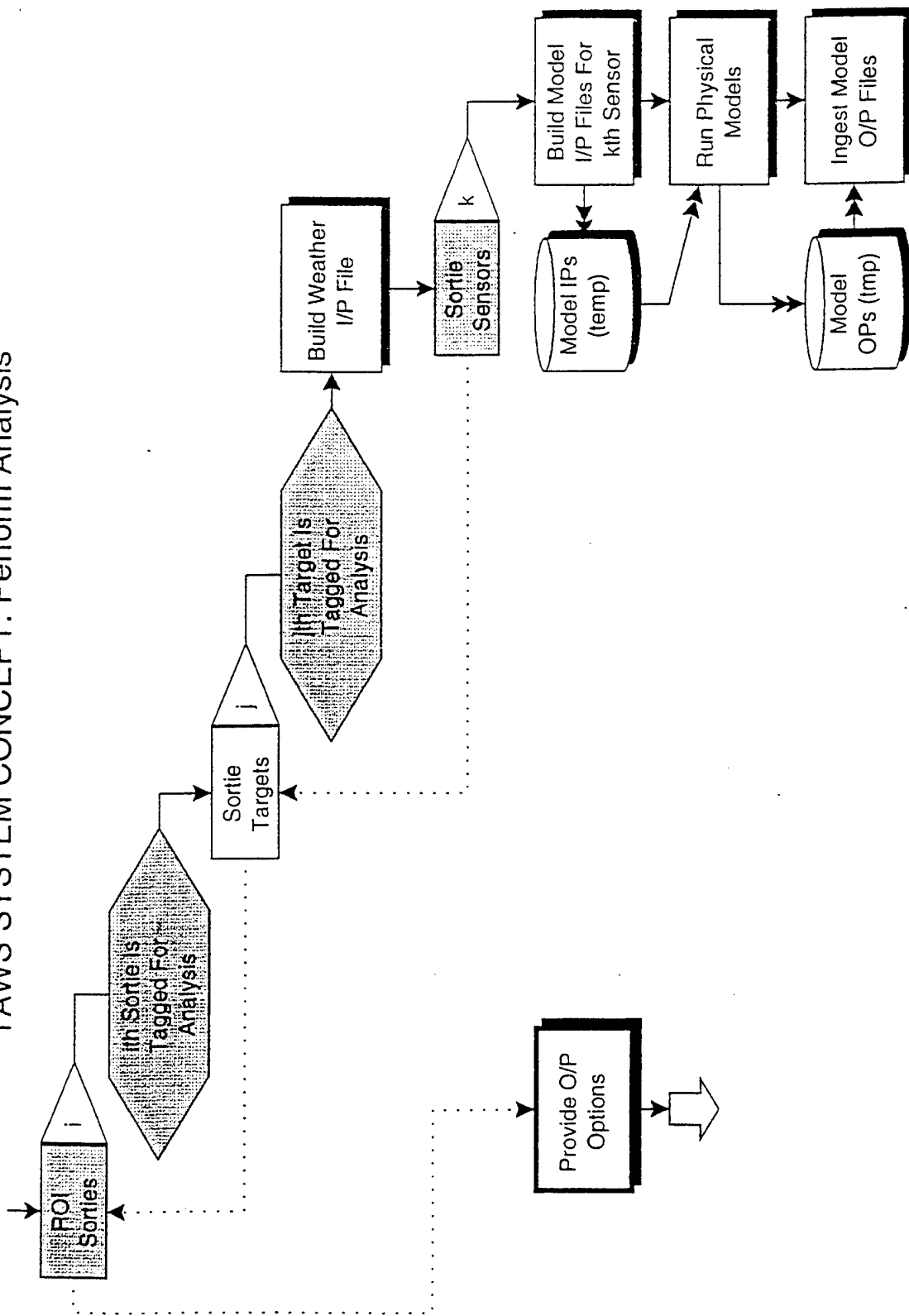

# TAWS SYSTEM CONCEPT: Provide Output Options

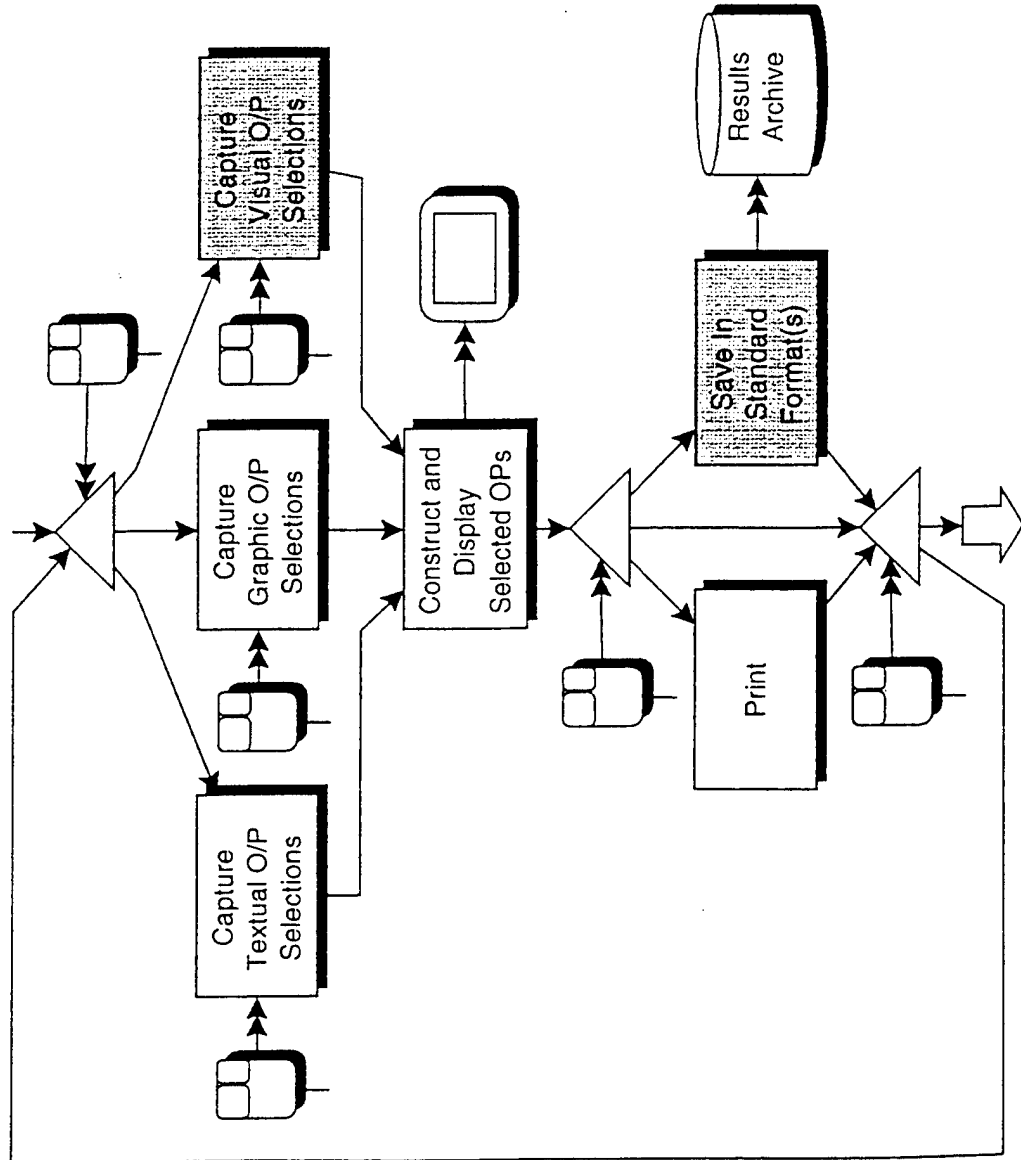



# TAWS SYSTEM CONCEPT: Set Current ROI

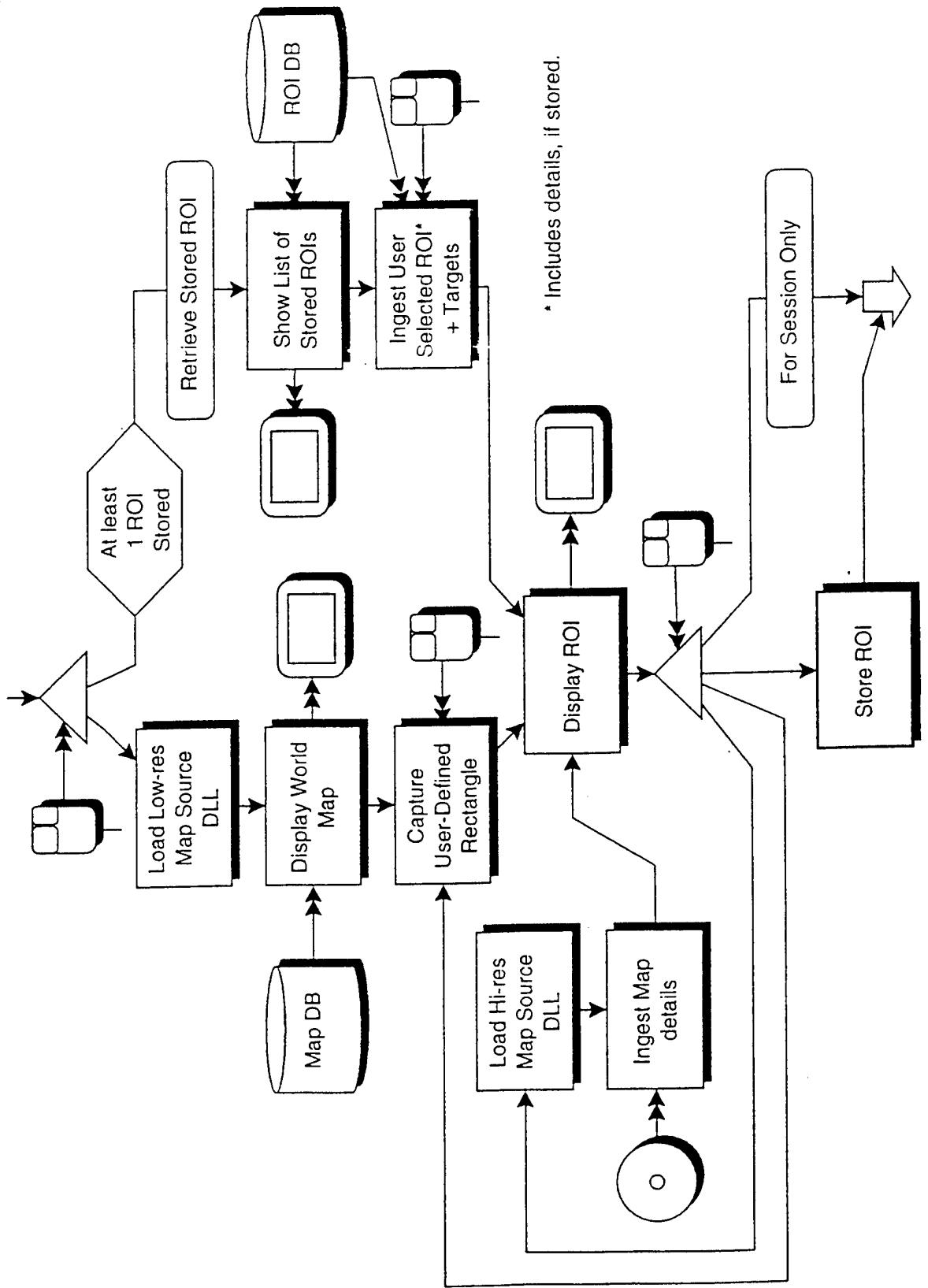

# TAWS SYSTEM CONCEPT: Setup Targets For ROI

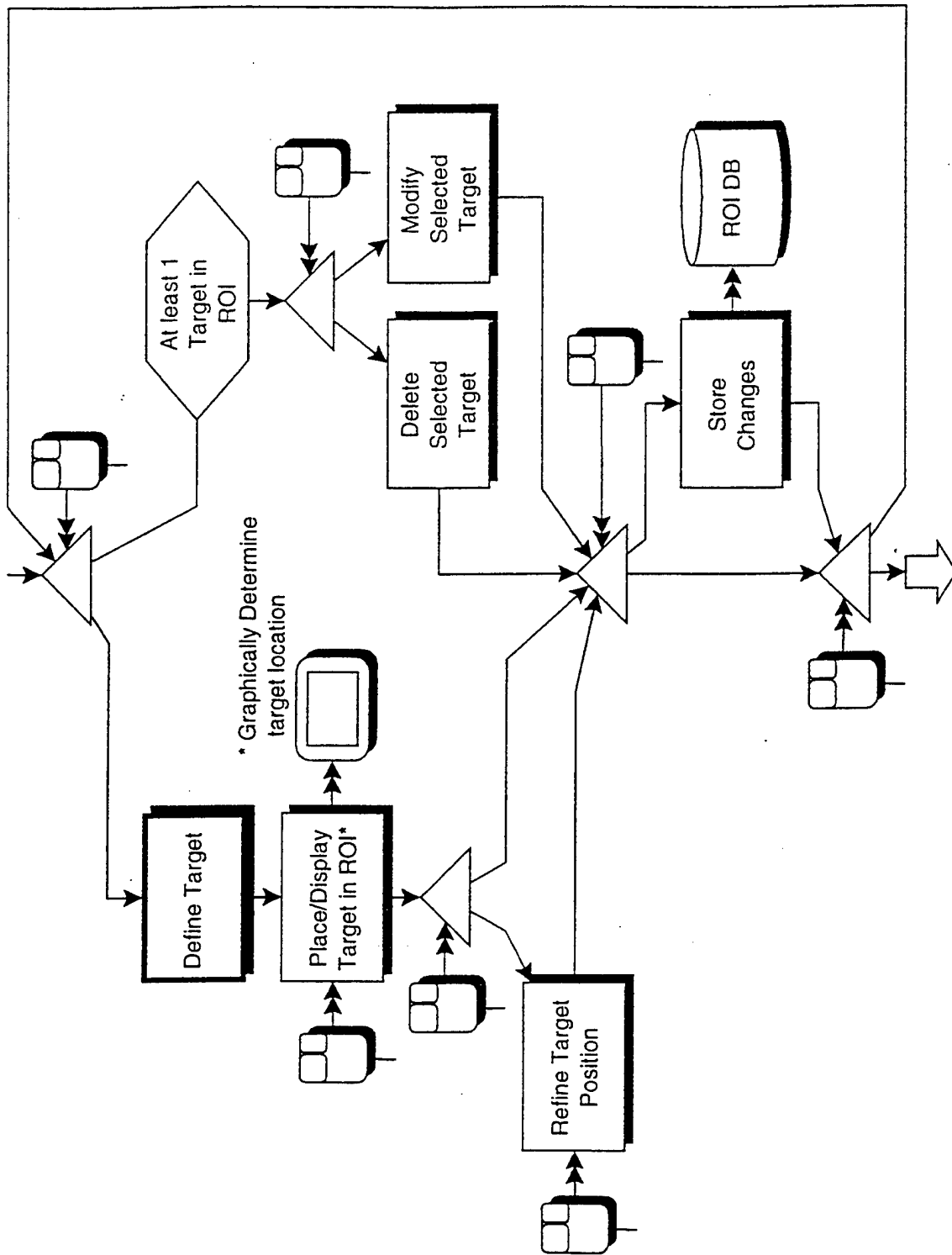

# TAWS SYSTEM CONCEPT: Setup Sorties For ROI

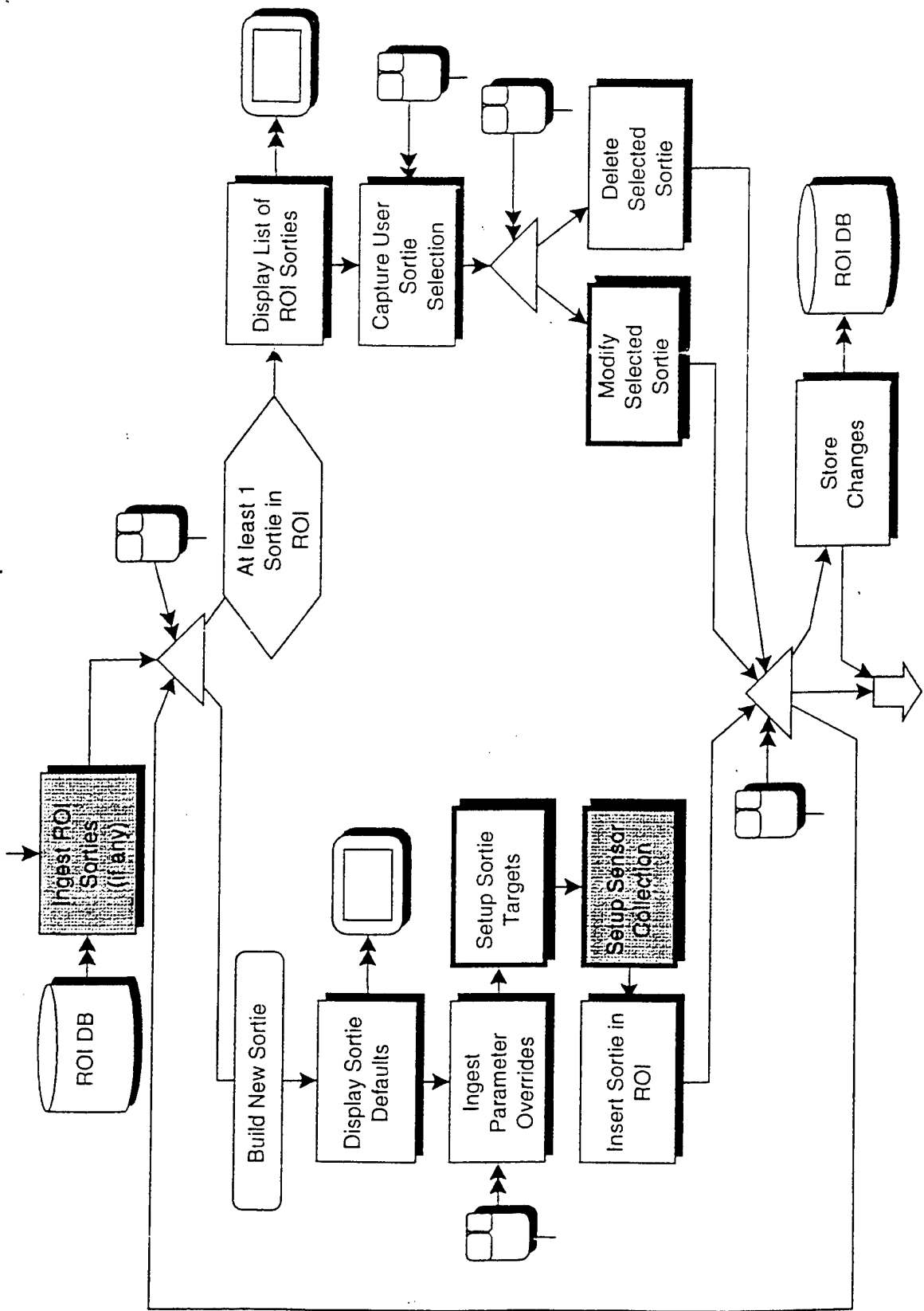

# TAWS SYSTEM CONCEPT: Setup Sortie Targets

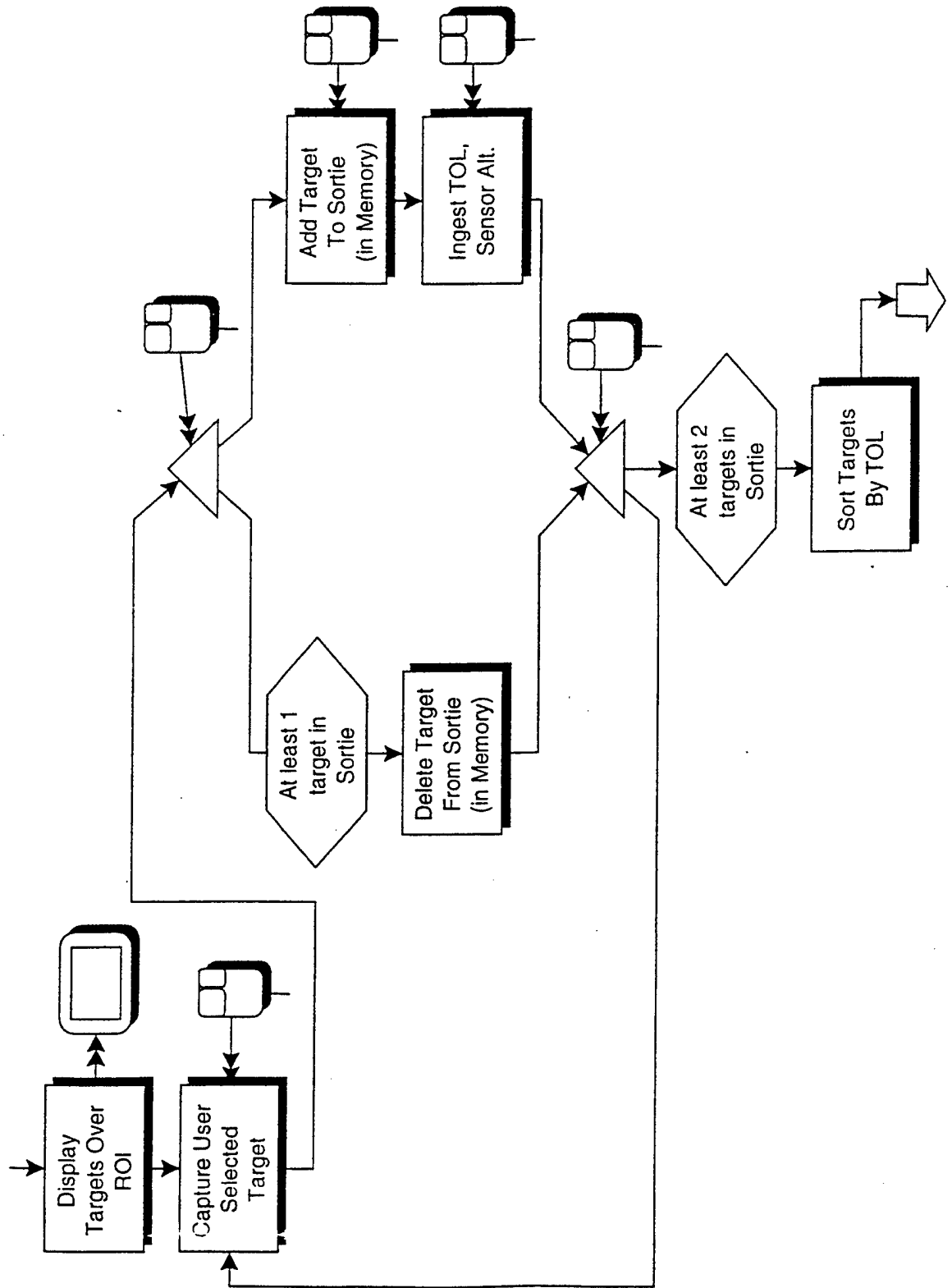

# TAWS SYSTEM CONCEPT: Modify Selected Sortie

