

072-04

P

**NASA TECHNICAL
TRANSLATION**

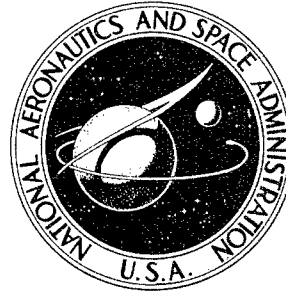

NASA TT F-238

NASA TT F-238

**Reproduced From
Best Available Copy**

AMPTIAC

DISTRIBUTION STATEMENT A
Approved for Public Release
Distribution Unlimited

**COLLECTED WORKS OF
K. E. TSIOLKOVSKIY**

Volume III-DIRIGIBLES

A. A. Blagonravov, Editor in Chief
USSR Academy of Sciences Publishing House,
Moscow, 1959.

**Copies Furnished to DTIC
Reproduced From
Bound Original**

20020319 059

NASA TT F-238

COLLECTED WORKS OF K. E. TSIOLKOVSKIY

VOLUME III - DIRIGIBLES

A. A. Blagonravov, Editor in Chief

Translation of "K. E. Tsiolkovskiy. Sobraniye Sochineniy.
Tom III, Dirizhabli."
Izdatel' stvo Akademii Nauk SSSR, Moscow, 1959.

NATIONAL AERONAUTICS AND SPACE ADMINISTRATION

For sale by the Clearinghouse for Federal Scientific and Technical Information
Springfield, Virginia 22151 - Price \$3.75

Printed Pursuant to the Resolution of 23 April 1948
of the Council of Ministers USSR

Edition prepared by the Commission for Preparing
for Publication the Works of K. E. Tsiolkovskiy,
Department of Technical Sciences,
Academy of Sciences USSR

Membership of the Commission:

Academician A. A. Blagonravov (Chairman),
Dr. Tech. Sci. V. A. Semenov,
Dr. Phys.-Math. Sci. A. A. Kosmodem'yanskiy,
Cand. Techn. Sci. M. K. Tikhonravov,
Engineer B. N. Vorob'yev (Scientific Secretary).

*

Chief Editor: Academician A. A. Blagonravov

TABLE OF CONTENTS

	Page
KONSTANTIN EDUARDOVICH TSIOLKOVSKIY, A PASSIONATE CRUSADER FOR A RELIABLE TRANSPORT DIRIGIBLE.	1
II. The Originality of Tsiolkovskiy's Scientific and Technical Ideas. A Glimpse into the Future. . . .	10
III. The Triumph of Tsiolkovskiy's Ideas.	14
IV. Recognition of the Works of K. E. Tsiolkovskiy. Their Historical, Scientific and Practical Value.	23
I. THEORY OF THE AEROSTAT	27
1. Conditions for the Equilibrium, Ascent, and Descent of the Aerostat.	27
Basic Formulas	27
Effect of Temperature and Pressure on Terms in the Above Formulas	29
The Walls of the Aerostat May Be Freely Compressed and Expanded.	32
Volume of Gas or Volume of Aerostat May Not Change	37
II. VARIATION IN AEROSTAT VOLUME.	41
Equal Gas and Air Temperatures.	42
Constant Resultant Force.	44
Vertical Movements of the Aerostat as a Cause of Changes in Its Volume	46
III. OF WHAT MATERIAL SHOULD THE AEROSTAT BE MADE?.	73

	Page
IV. CERTAIN CONDITIONS WHICH MUST BE SATISFIED BY ANY DIRIGIBLE	77
V. BRIEF DESCRIPTION OF A METAL AIRSHIP.	79
VI. THE SHAPE OF A DIRIGIBLE.	87
Shape of the Envelope	87
Shape of Transverse Section of a Cylindrical Aerostat	89
1. The Hydrostatic Model	90
2. Thread Model.	91
3. Analytic Determination of the Shape of the Cross Section	97
VII. THE CORRUGATED METAL SKIN OF THE AEROSTAT.	119
STRETCHING AND BENDING OF THE SURFACE.	119
Surface of Revolution Transformed into a Double Plane	119
Geometrical Calculations.	124
Mechanical Calculations	136
Minimum Dimensions of Envelope. Application to Various Shapes.	146
Stretching of the Corrugated Surface in General	157
Application of the Formulas to Straight Corrugations. Various Systems of Folding and Convolute Metal Envelopes	162

	Page
VIII. THE PRINCIPAL LONGITUDINAL CROSS SECTION OF THE ENVELOPE AND ITS PROPERTIES. SURFACE AND VOLUME OF THE ENVELOPE. MOMENT OF THE WEIGHT OF THE ENVELOPE AND MOMENT OF THE LIFTING FORCE OF THE GAS .	164
Choice of Longitudinal Section of Envelope.	164
General Formulas.	173
Application of the General Formulas to a Parabola (Conic Section)	177
Radii of Curvature for Various Curves	184
Area of Maximum Longitudinal Section for Different Shapes.	190
Length of Arc of Principal Longitudinal Section	192
Surface Areas of Different Bodies of Revolution	197
Volumes of Different Bodies of Revolution	202
Moments of Envelopes of Different Shapes.	204
Moment of Lift Force for Envelopes of Different Shapes.	207
IX. PRESSURE OF GAS ON CROSS SECTION OF AEROSTAT. CENTER OF PRESSURE.	212
X. A SURVEY OF THE PRINCIPAL FORCES ACTING ON THE ENVELOPE OF THE AEROSTAT; THEIR INTERRELATIONSHIPS	222
Longitudinal Forces	222
Transverse Forces	231

	Page
XI. MODIFICATION OF THE COMPONENTS OF A METAL AIRSHIP	241
Various Aerostat Systems.	241
Tensioning by Pulleys	246
Screw Tensioning.	251
Devices Used in Gravity Tensioning.	252
Does a Gravity Tensioning System Have to be Secured?.	256
Complete Absence of Tensioning.	257
Conclusions Concerning the Above Designs.	262
XII. DESIGN OF CERTAIN COMPONENTS OF A PARABOLIC AEROSTAT, AND THEIR WEIGHT.	264
Center of Wind Pressure on Envelope	264
Mean Position of Center of Pressure of Air Stream on Envelope. Length of the Girders	266
Equation of the Longitudinal Girders of a Deflated Metal Aerostat.	267
Length of Stiffening Hoops and Inclination of Girders to Longitudinal Axis.	271
Cross-Sectional Area of Longitudinal Girders and Their Weight in the Case of a Variable Cross Section (Strength of Envelope Neglected; Gravity and Lift Force Moments Equal).	272
Weight of Longitudinal Girders in the Case of a Constant Cross Section.	278

Weight of Stiffening Hoops of Constant Cross Section (Strength of Envelope Neglected).	279
The Weight of Stiffening Hoops of Variable Cross Section (Strength of Envelope Neglected).	282
Strength of Envelope: Transverse and Longitudinal Strength. Weight of Envelope	285
Weight of Envelope of Constant Thickness when its Strength is Neglected	291
Weight of Cylindrical Longitudinal Strips Forming the Top and Bottom of the Envelope for the Case of Constant Width.	292
Weight of Main Vertical Rod-Chains.	293
Weight of Passengers and Motors	294
Weight of Gondola, Control Surfaces, and Propellers . . .	294
Black Inner Tube for Heating the Light Gas.	296
XIII. CALCULATION OF THE HEIGHT OF THE SHELL OF A BALLOON . . .	298
XIV. MOTION OF AN AIRSHIP	320
A. Independent Uniform Horizontal Motion	320
B. Inertia of a Vessel (Inertial Range).	340
C. Relative Resistance, Specific Surface, and Specific Volume	347
XV. HEATING OF LIGHT GAS AND ADJUSTMENT OF LIFT	354
2. ELEMENTARY DESIGN OF A METAL DIRIGIBLE	377

	Page
I. Description of the Drawings	377
II. Advantages	386
3. THE DESIGN OF A METAL DIRIGIBLE TO CARRY FORTY PASSENGERS.	392
I. Design Fundamentals	392
II. Some Theoretical Remarks	394
Shape of Longitudinal Section of Dirigible Envelope	394
The Role of the Envelope Bases	395
Slope of the Envelope Corrugations	395
III. Notes on Use of Table	403
IV. Design Features of a Metal Dirigible	415
Modifications and Simplifications.	457
V. Sequence of Practical Operations in the Construction of a Metal Dirigible.	459
4. COMPENDIUM OF THE CORRUGATED STEEL DIRIGIBLE	473
I. General Table for Dirigibles 60-300 Meters in Length.	476
II. Notes on Use of Table.	483
APPENDICES	492
THE WORKS OF K. E. TSIOLKOVSKIY.	501

KONSTANTIN EDUARDOVICH TSIOLKOVSKIY, A PASSIONATE
CRUSADER FOR A RELIABLE TRANSPORT DIRIGIBLE

by

Honored Activist of Science and Engineering, RSFSR,
Dr. Techn. Sci. Professor V. A. Semenov

In the second half of the nineteenth century mankind, in its struggle for mastery of the air, placed its greatest hopes in the dirigible.

Dmitriy Ivanovich Mendeleev, one of the greatest Russian men of science of the time, was confident of the rapid development of heavier-than-air flying machines. Though he considered that human understanding of these machines ("aerodynamos") was "still rudimentary, on a scale incommensurate with our needs," nevertheless, he expressed the opinion that "this kind of aeronautics promises to have the greatest future and to cost the least and is, so to speak, conditioned by nature itself, since birds are heavier than air and hence aerodynamos."* But while asserting that the future belonged to aircraft, Mendeleev did not recommend abandoning the possibilities of the present; with the potentials of his time in mind, he declared: "Only aerostats promise to yield quick and concrete results, the more so as in their case the main outlines of the whole problem are perfectly clear from the theoretical standpoint. It is for this reason that priority should be given to extensive practical experiments with a properly designed aerostat.

Without being frivolous or visionary, I can state with full assurance that a large aerostat can be just as maneuverable as a

*From a letter by D. I. Mendeleev to the Ministry of War in 1878.
The D. I. Mendeleev Archival Museum.

ship."*

K. E. Tsiolkovskiy's views on controlled flight were in complete accord with those of Mendeleev.

Tsiolkovskiy, in elaborating his idea of a safe dirigible, critically examined all the known attempts at dirigible design and found them inadequate from the point of view of safety. He rigorously defined the essential reliability requirements for the guidance of inventors and designers and offered his own original design for an all-metal dirigible.

Tsiolkovskiy conceived the idea that designing of an all-metal dirigible would revolutionize human culture and economic life in his youth. He realized, however, that the society of his time and, primarily the chief representatives of the scientific and technical community, would not be interested in his ideas unless and until he could provide exhaustive scientific and experimental proofs of his competence, until he could win recognition from the scientific world. Otherwise, he would get no help in solving the problems that interested him, and, as a mere unknown, would be treated with the deepest mistrust.

As is clear from various autobiographical notes, Tsiolkovskiy also realized that in his time the road was open only to wealthy and influential people, whereas he himself was both poverty-stricken and obscure and, moreover, handicapped by the deafness, which deprived him of the opportunity of obtaining an education by the normal practice of attending school and college. Thus, the only path he could follow was to advance himself by his own scientific labors, to strive for acceptance of the idea of the all-metal dirigible by presenting irrefutable scientific conclusions and, in this way, to work for recognition of the value and necessity of translating his ideas into reality.

In the winter of 1880, while working as a teacher in a Borovsk school, Tsiolkovskiy started his single-minded and comprehensive studies of the theory of the aerostat; it was then that he arrived at definite and rigorously scientific conclusions on the possibility of maneuverable aerostats and the expediency of building giant vehicles of this kind. While pursuing his investigations of the possibility of designing such airships, he concluded that only metal airships were worth building.

*Ibid.

О возможности
 постройки металлическаго
 аэростата, способнаго
 изменять свой объем
 и даже складываться
 въ плоскость

Боровскъ, Калужскій
 уездный училищный
 Константинъ Циолковскій

Первый лист рукописи «О возможности построения металлического аэростата», посланной К. Э. Циолковским Д. И. Менделееву в 1890 г.

"On the possibility of constructing a metal aerostat capable of changing in volume and even folding flat.

Borovsk, Kaluga...Teacher at the District School....Konstantin Tsiolkovskiy...

(Page one of the MS of "On the Possibility of Building a Metal Aerostat," sent by K. E. Tsiolkovskiy to D. I. Mendeleev in 1890.)

Применение к теореме
 По уравн. № 16 вычисляется
 наибольший радиус кольца,
 ибо, когда у кольца один
 центр но два окружности
 и два радиуса. Тогда
 наибольший радиус вычислен
 из радиуса кольца, надо
 из радиуса вычитать
 радиус вычитаю (d/2)

Конст. Эд. Циолковским
 учителем Боровского уезд
 го училища.
 30 августа 1890 года.

Последний лист той же рукописи

"Appendix to the table

"Eq. 16 is used to calculate the maximum radius of the ring, since the ring has one center but two perimeters and two radii. In order to obtain the radius of the inner arc of the ring, the radius of the outer ring must be subtracted.

"Konst. Ed. Tsiolkovskiy, teacher at the Borovsk District School.

"30 August 1890."

(Last page of the same MS)

But Tsiolkovskiy did not immediately present his conclusions, the fruit of his basic research, to the scientific institutions or to the press.

He was not worried that someone else might appropriate his ideas; his concern was rather that flaws in the scientific and technical presentation of his ideas might provide his adversaries with an excuse for casting doubt on them. And so, though not an engineer and lacking any experience in engineering design, he decided to solve all his problems by dint of his own research. Thanks to his great talents and years of obstinate toil, Konstantin Eduardovich did indeed attain exceptional results.

Instead of merely designing an airship of no matter what kind, so long as it would fly, from the very outset K. E. set himself the most difficult task, that of designing a vehicle that would be ideal from every point of view: safe, simple, operationally convenient, and economic.

It was by following this path that he arrived at the conclusion that the vehicle must be made entirely of metal. He reasoned primarily that this would safeguard his (inflammable hydrogen-filled) airship against its greatest enemy -- fire. As for fire itself, K. E. considered it a means of improving the operating qualities of the dirigible, by heating the gas inside it. It was thus that the brilliant idea of "uniting fire and metal" was born in the author's brain.

In 1886 K. E. Tsiolkovskiy had already completed his first major work on the theory and design of the aerostat; it was not published at the time, but the MS was entitled "Teoriya aerostata" (Theory of the Aerostat).^{*} Confident in his accomplishments in basic research, in 1887 Tsiolkovskiy presented a report on them in Moscow at a meeting of the Physics Section of the Society of Amateurs of Natural Science. The report was received with approval.

A different reaction was provoked by this report when it was submitted to the Seventh Aeronautics Division of the Russian Technical Society, which discussed it in the author's absence in October 1890. It turned out that the Aeronautics Division lacked faith in the future of maneuverable airships, as reflected in its decision, communicated to Tsiolkovskiy in Borovsk: "1) It is highly likely that

^{*}The full title of the MS was: "Teoriya i opyt aerostata, imeyushchego v gorizonta'l'nom napravlenii udlinennuyu formu" (Theoretical and Experimental Aspects of an Aerostat Elongated in the Horizontal Direction).

metal aerostats will be built; 2) Tsiolkovskiy may render great services to the cause of aeronautics; 3) the construction of metal aerostats is extremely difficult; 4) the aerostat (in the opinion of the society) is doomed for ages, by the very nature of things, to remain a plaything of the wind."*

In 1891 K. E. Tsiolkovskiy turned to the eminent Russian scientist Professor A. G. Stoletov with a long letter in which he elaborated his idea of the metal airship.

Subsequently, Tsiolkovskiy began to publish his work in separate articles. Since he found it difficult to publish everything at once (about 300 pages), and thought some polishing up of his manuscript of the "Theory of the Aerostat" still necessary, he divided it into individual articles, revised and expanded each article and published them consecutively over a period of years (1892-1908).

His inability to gain the material support of the official scientific and technical community forced the author to appeal to a broader stratum of society; he rewrote his mathematical work in popular language and asked those in sympathy with him to read his book, in the belief that this alone would suffice for his irrefutable conclusions to win recognition.

The publication of Tsiolkovskiy's "Maneuverable Metal Aerostat" in 1892 was followed by a second edition of the same book in 1893 and, in the same year, by his short article "Is a Metal Aerostat Feasible?" and the treatise "A 200-Man Maneuverable Iron Aerostat" and, in 1897, by the book "Independent Horizontal Motion of a Maneuverable Aerostat"; in 1898 there appeared the book "A Simple Account of the Airship (Popular Exposition)"; in 1905, a short article "The Metallic Airship," and, lastly, during 1905-1908 K. E. succeeded in having the greater part of his original work "Theory of the Aerostat" published in the journal "Vozdukhoplavatel'" (The Aeronaut) under the title "The Aerostat and the Airplane," after extensive revision by the author.

Thus 22 years passed from the time K. E. first drafted his manuscript of "Theory of the Aerostat" before most of its contents were finally published.

The publication of Tsiolkovskiy's works met with a varied response from the Russian and foreign press.

In 1897 "Moskovskiy vestnik" (The Moscow Herald) declared:

*As reported by Tsiolkovskiy on page VII of his book "Prostoye ucheniye o vozdushnom korable i yego postroyenii" (A Simple Account of the Airship and Its Construction). Kaluga, 1904.

"No one is a prophet in his own country. This concerns a Russian scientist from Kaluga, Tsiolkovskiy.... In 1893 this compatriot of ours, a scientist-theoretician, published a brochure entitled 'The Maneuverable Metal Aerostat.' Neither the general nor the specialized press of Russia considered it necessary to make the least mention of this brochure, which in the meantime has been translated into the French, German and English languages and has given birth to a stimulating debate abroad. It was sinking into oblivion when it was rescued by André's flight. A French periodical states that had André read this book he would never have undertaken his senseless flight*.... So far so good, but one question remains: why did Russian scientists consider it necessary to snub Tsiolkovskiy?"

Even earlier, the journal "Razvedchik" (Explorer) declared: "Tsiolkovskiy is a fanatical scientist obsessed by the idea of the maneuverable metal aerostat. It appears that he has been working on this idea for more than ten years; he has had published an entire book entitled "The Aerostat" and a brochure "The Airplane," and he has written many manuscripts. Moreover, he has conducted a whole series of interesting experiments on the resistance of air to oblong bodies and has constructed a model of an aerostat to prove that metal can be used in aerostat construction.... Tsiolkovskiy's work "The Maneuverable Iron Aerostat," clearly the fruit of solid labor, is couched in very concrete language and deserves following up."

In 1904 Tsiolkovskiy's proposals were discussed in Kaluga by a group of engineers. They concluded, among other things, that his project was definitely feasible, highly important, and indisputably correct from the theoretical standpoint.

Following is the text of a press report of these conclusions: "The author of this project, as his numerous published works demonstrate, has rigorously and comprehensively studied and elaborated the entire theory of aeronautics, carried out a great deal of mathematical and experimental research in this field, weighed all the known principles of aeronautics and, in drafting his project, guided himself only by incontestable principles established on the basis of the enormous material he has explored and developed. The airship of K. E. Tsiolkovskiy is the result of persistent toil and the zealous pursuit of an idea. It is to be hoped that these remarks

*In 1897 the Swedish engineer André (born 1854), together with two companions, Strindberg and Fraenkel, attempted to fly by balloon from Vigo Island (Spitzbergen) to the North Pole; all three perished without achieving their goal.

will not pass unnoticed and that both the public and the press will remember the existence of this project of our compatriot Tsiolkovski and support its materialization."* This is followed by the signatures of 14 mechanical engineers, technologists, railroad engineers, and candidates of mathematical sciences.

In 1908 Tsiolkovski completed a manuscript entitled "The Heating of a Light Gas and the Resulting Change in the Lift of an Aerostat," which represented part of the unpublished manuscript of his very first theoretical work, "Theory of the Aerostat" (1886). According to the engineer B. N. Vorob'yev, who studied the literary legacy of K. E. Tsiolkovski, the contents of this manuscript represented Chapter XVI of Part I of "The Aerostat and the Airplane," prepared for the press and published during 1905-1908 in the journal "The Aeronaut," in St. Petersburg, but not printed on the scale anticipated. This chapter was entitled by K. E. "Thermal Calculations of the Dirigible." He wrote of it: "These calculations were made long ago and were supposed to be published in 'The Aeronaut' as a continuation of my major work 'The Aerostat and the Airplane.' But that journal became the official organ of the Aeroclub, and so the publication of my work was discontinued."**

Devoted to his idea of an all-metal dirigible, Tsiolkovski continued his arduous work despite lack of active response from the scientific public.

In 1910 two of his articles appeared in the press: "The Metal Aerostat, Its Advantages and Conveniences," and "A Metal Bag of Variable Volume and Shape."

Tsiolkovski's files were found to contain the manuscript of his preface to one of these articles, beginning with the epigraph: "This may be found true when I am no longer here. I shall be gone, but logic will always remain."

The new works of K. E. aroused further response, but once again it was isolated and ineffective and at best provided the author with moral support.

In 1912 the journal "Elektrichestvo i zhizn'" (Electricity and

*The conclusions of the group of engineers in Kaluga were published separately on page 4 (Kaluga, 10 July 1904) and immediately afterward reprinted in various Russian newspapers and periodicals.

**B. N. Vorob'yev. "On K. E. Tsiolkovski's 'Heating of a Light Gas.'" Sbornik No. 6 nauchno-tekhnicheskikh rabot po vozdukhoplavaniyu (Coll. No. 6 of Scientific and Technical Works on Aeronautics), publ. by Aeroflot, Moscow, 1938, pp. 1-14.

Life) printed the following: "Tragic is the fate of this talented and erudite inventor. His numerous discoveries have remained unnoticed and, in the course of time some of them have been ascribed to other inventors.... The future historian of physics will doubtless note the amazing persistence of our compatriot whom we, his contemporaries, did not appreciate.... Apparently he is too far ahead of his time and his country."

In 1914 "Golos Moskvyy" (The Voice of Moscow) declared: "An evil fate plagues Russian inventors.... Few have heard of K. E. Tsiolkovskiy... whereas the names of Wright, Zeppelin, and the like, are on everybody's lips.... Tsiolkovskiy's lot is truly to be deplored.... Many of his theoretical conclusions seemed at one time to be so strange as to perplex even specialists. And yet, nearly all of them have since been proved in practice -- but alas not in Russia. Here are a few typical examples: in 1895 Tsiolkovskiy was the first to describe the airplane* and provide a correct mathematical description of all its parts. More than ten years later the airplane was built; in the 'nineties he proved the feasibility of maneuverable aerostats, and now dirigibles have become an accepted fact; in 1903 he published a study of the theory of motion of projectiles based on the rocket principle. Three years later this principle was put to military use in America and Sweden; in his studies of the resistance of air Tsiolkovskiy proved a theorem that at first glance seemed paradoxical: that the pressure of a flow normal to a plate depends on the elongation of the plate.** This conclusion won recognition only after Eiffel's experiments. In 1897 Tsiolkovskiy expressed new ideas on the emissive life of stars; two years later these ideas were published by an American scientist, who retained the honor of being the discoverer. And now, finally, Tsiolkovskiy is working on a grandiose task -- metal aerostats.... In the brochure which he has sent me [i.e., the author of the notice in "Golos Moskvyy" -- V. S.] he touchingly appeals for the confidence of the public: "The leitmotif of my life has been to accomplish something of benefit to mankind, to live a useful life. That is why I was interested in doing something that brought me no personal gain; but I hope that my work will provide society with abundant material

*The author of this newspaper report apparently was unaware of the research done by A. F. Mozhayskiy during 1880-1885 -- V. S.

**This discovery by K. E. is described in Volume 1 of his Collected Works, Academy of Sciences USSR Press, 1951, pp. 6 and 7 [V. S.]

wealth and magnified powers."*

The above quotations demonstrate that many had recognized the scientific validity of Tsiolkovskiy's conclusions and the indisputable advantages of his airships to the national economy, should they be built. But dozens of years passed without any one in Russia or abroad undertaking to realize Tsiolkovskiy's proposals.

II. The Originality of Tsiolkovskiy's Scientific and Technical Ideas. A Glimpse Into the Future.

With his project for an all-metal dirigible K. E. Tsiolkovskiy proved to be ahead not only of all his fellow inventors but also of his time.

His period of activity followed more than 100 years after the first aerostat in the history of mankind had been invented and flown, and yet mankind still lacked maneuverable aerial vehicles. Previously only diffident attempts had been made at constructing tiny dirigibles, barely able to make an ascent even without a load. The reliability and transporting powers of these dirigibles were simply not worth mentioning.

The maximum speed of the best dirigible of those times did not exceed 20 km/hr, and the craft was powerless against gusty winds. Many were skeptical of further progress and made rash statements such as: "the aerostat will always remain a plaything of the winds."

Tsiolkovskiy had to contend with this atmosphere of disbelief in the future of aeronautics when he first made public his radical ideas.

In his view, the wind problem could be solved by following an easier, though longer, route; moreover, K. E. was confident in the inevitability of an increase in engine power, in technical progress. The most fundamental problem awaiting solution at the time was, in his opinion, that of insuring a longer flight time, but this could not be accomplished with dirigibles with fabric envelopes, which

*All the excerpts cited here are from notices published in the preface to K. E. Tsiolkovskiy's brochure "Aerostat of Corrugated Metal Dirigibles," Kaluga, 1927, p. V.

leaked gas and lost lift and therefore could not remain aloft long. Moreover, Tsiolkovskiy regarded the fabric envelope as insufficiently strong and a fire hazard; since it was not airtight, air could penetrate and, once inside, mix with the hydrogen, i.e., form an inflammable mixture which a random spark could transform into fiery death for the ship and its passengers.

Among the other disadvantages of fabric envelopes Tsiolkovskiy mentioned the piloting problems due to the variability of the dirigible's lift and the inability of the pilot to control the static equilibrium of the vehicle by suitably altering the gas temperature in the balloon: heating the gas inside a fabric envelope struck Tsiolkovskiy as a serious fire hazard to the entire dirigible. Lastly, the fabric envelope limited the size of the dirigible and hence the possibilities of a marked increase in its load capacity.

In view of these considerations, Tsiolkovskiy began to advocate the idea of huge dirigibles with an all-metal envelope.

Since a metal envelope is not inflammable and the gas inside it cannot escape, K. E. thought it possible to heat the hydrogen artificially in flight without incurring any fire risk; by this means he hoped to provide the dirigible with constant and perfect vertical maneuverability.

In order to enable the gas to expand freely during the ascent of the vehicle or in the event of excessive heating, and in order to prevent a fall in pressure (as compared with the pressure of the outside air) during the descent of the vehicle or on cooling of the gas inside the envelope, the dirigible envelope should, in Tsiolkovskiy's opinion, be capable of changing volume, i.e., shrinking and expanding.

From the standpoint of design, Tsiolkovskiy's proposal reduces to concentrating all the weight of the vehicle in the envelope, which would thus serve as both gas container and structural skeleton.

This consideration convinced Tsiolkovskiy that the larger the volume of such a dirigible the greater its advantages.

Despite all the persuasiveness of his arguments, however, they were not utilized in actual dirigible construction.

The low level of technology at the time, the difficulty of making gastight seams in balloon envelopes, and the complexity of the actual construction of a metal envelope of variable volume -- all this forced the builders of small dirigibles to employ soft fabric balloons and a rigid framework system in building large ones.

Thus, Tsiolkovskiy's ideas found no immediate support either in Russia or abroad.

His ideas were dozens of years ahead of the science and technology of his time.

The subsequent development of the technology of dirigible construction shows that Tsiolkovskiy's ideas were adopted by other

authors who, however, treated them as recent discoveries, without mentioning the name of Konstantin Eduardovich.

Thus, while the end of the nineteenth century was mainly characterized by the development of ideas and designs for different dirigible systems and little actual construction, the beginning of the twentieth century was marked by the successive development of several types of dirigible.

Regarding the dirigible as a means of transport, during 1886-1892 Tsiolkovskiy showed why small dirigibles are unsuitable for this purpose and proposed a design for a giant dirigible. The boldness of his concept frightened his contemporaries.

In practice, during the period from 1890 to 1910 emphasis was placed on the development of small dirigibles mainly -- with the exception of the German zeppelins -- of the nonrigid type. Experience has shown that these dirigibles are unsuitable for transport purposes.

As Tsiolkovskiy had foreseen, fabric dirigibles of the nonrigid type proved to have a low load-carrying capacity and a high dead load factor, as well as an extremely limited provision for fuel supplies, a short radius of action, and a very low ceiling.

All this restricted their usefulness to the performance of special services only. As a rule, their volume did not exceed 5000

to 8000 m³, whereas for transport purposes large-volume dirigibles were needed.

The dirigibles most popular around 1925 were of the so-called semirigid type (with a fabric envelope combined with a rigid metal keel extending longitudinally along the bottom of the ship from nose to stern) with flying and steering qualities greatly superior to those of the nonrigid ships; the volume of the semirigid ships reached as

much as 10,000 to 20,000 m³ but even they were still unsuitable for organized passenger service. The problem of the safety of long-range flights in these dirigibles could not be satisfactorily solved. As Tsiolkovskiy had foreseen, the needs of an aerial transport fleet could only be satisfied with much larger ships.

As far back as 1892 K. E. had pointed out the need to design a 200-man transport dirigible, i.e., a giant airship, and he commenced his investigations with the problem of insuring its operational safety. Tsiolkovskiy's idea that a true transport dirigible is possible only if its volume is enormous (hundreds of thousands of cubic meters) found its embodiment abroad where about 1930 gigantic

dirigibles with a volume of 100,000 to 2,000,000 m³ began to be built. But the foreign designers followed a reasoning different from that of Tsiolkovskiy. The giant ships R-101 in Great Britain, Akron and Macon in the United States, and Hindenburg in Germany, the design of

which was based on the German dirigibles (zeppelins), did not meet Tsiolkovskiy's principal safety requirements. Life itself cruelly showed how right Tsiolkovskiy was: all four crashed and many lives were lost.

For forty years (1895-1935) the foreign proponents of transport dirigibles argued in favor of the superiority of the zeppelin system. It is characteristic of the prickly and costly path of development of dirigible construction that firms were commissioned merely to improve on a predetermined design; the blind reluctance, or rather failure to apprehend the advantages of investing capital in other, more progressive ideas of dirigible construction, ultimately led to the bankruptcy of the entire idea of transport dirigibles, in Germany, in the United States and in Great Britain.

The colossal expenditure of effort and resources on dirigible construction during these forty years is eloquent proof of the enormousness of the aerial transport needs of the countries named. The disasters encountered by the giant dirigibles owing to design defects and errors in operation led to the halting of the construction of further airships.

It is significant to note that the abandonment of airships in the United States, Great Britain and elsewhere was motivated by the failure to solve the problems of the construction of transport dirigibles rather than by any sudden disappearance of the need for this means of transport.

The colossal capital investments in dirigible construction in the United States, Great Britain, and Germany, which continued until the final aerial catastrophes (until 1937), indicate that though the need for transport dirigibles was enormous a reliable, safe and operationally simple dirigible just could not be developed. The foreign designers paid a cruel price for their errors, which confirmed the validity of Tsiolkovskiy's scientific and technical ideas, based on the unconditional requirement of operational safety.

Of course, now, in the mid-twentieth century, when we consider Tsiolkovskiy's work on all-metal dirigibles, we should examine it not in the light of the technology of 1886-1892, when K. E. formulated his first technical concepts, but in the light of our present possibilities as defined by the latest achievements of science and engineering.

Although the basic idea remained the same, the last zeppelins to be built (1930-1935) differed from the original zeppelins (1900) in method of design and in certain structural details.

K. E. always tested his theoretical concepts with the aid of mathematical analysis and experiments on models. As part of his metal envelope project, K. E. made a mathematical analysis of the stress distribution in the envelope as the shape of its cross section changed. In checking his design of a metal envelope of variable

volume, K. E. verified his computations on models. By means of exact geometrical calculation he succeeded in making the models vary in volume smoothly and flexibly, from a flat box to a solid of revolution and back again.

In the last years of K. E.'s life work on models of envelopes for his airship was carried on by a special design office and reflected the technological level of the thirties.

K. E.'s death led to a cessation of work on his dirigible at a stage at which not only was the craft still incomplete but not even a working design of the ship as a whole had been prepared.

In our day science and technology are developing at a headlong pace, and an interval of 20 to 30 years may thus represent a major period in history. Therefore, the future builders of transport dirigibles will probably examine largely from the historical standpoint the individual design solutions once proposed by K. E. Tsiolkovskiy, while focusing their search for valuable hints and suggestions on his scientific and technical theories on the safety of dirigibles -- theories that cannot grow obsolete.

There is not a grain of doubt that had Tsiolkovskiy's technical concepts been actually applied to dirigible construction in the last 60 years, all the structural components of his dirigible, and the ship as a whole, would have passed through many stages of improvement and, as indicated by experience in the development of the zeppelins, in its present-day form, had it existed, it would not only have borne very little resemblance to the 1890 version but would have greatly surpassed the accomplishments of 1935 with respect to the envelope design.

Thus, while a designer may pass lightly over those of Tsiolkovskiy's technical solutions that by now are mainly of historical interest, he will find the substance of K. E.'s work to contain much that is of value and proof positive of the supremacy of the author's scientific and technical ideas, where our present accomplishments in dirigible construction are concerned.

III. The Triumph of Tsiolkovskiy's Ideas

The potential of giant dirigibles as high-capacity freight carriers capable of nonstop trips lasting several days over any route on earth and across any ocean has impelled nearly every major nation to attempt to develop such airships.

This has not proved to be an easy matter. The countries which suffered resounding failures in the use of dirigibles -- failures that involved disasters with, as a rule, great loss of human life -- appear to have lost nearly all hope of surmounting the design, production and, particularly, operational difficulties that came to light.

Among these unsuccessful countries are France, Great Britain, Italy, and the United States; they all (except the United States) abandoned further development of dirigibles, especially giant dirigibles. Germany, which also suffered tremendous losses (in 1937 the crash of the world's biggest airship, the Hindenburg), instead of drawing pessimistic conclusions announced an expansion of its program of dirigible construction.

The foreign press has more than once asserted that airships, capable of floating in the air for days on end, are greatly needed in peacetime as well as in war, but first there is a need for innovations in the technology of dirigible construction with the aim of improving the airworthiness of these ships and eliminating the chances of fatal accidents.

The authors of these comments maintained that the dirigible cannot compete with the airplane: its role begins where that of the airplane ends.

Everyone remembers the measures taken by the Germans during 1930-1935 to use giant zeppelins to establish major air links between Europe and South and North America. At that time, Germany succeeded in building a global network of dirigible bases with hangars and mooring masts. In South America these bases used the facilities of the extensive local German-organized airline network, while in the Atlantic floating bases on board specially equipped sea-going ships were introduced.

Dirigibles could also perform another and no less important civilizing function. The solution of the principal problems of the design, production and operation of huge transport dirigibles, and the development of a dirigible design of maximum operational simplicity and reliability, assuring maximum flight safety, would provide a basis for organizing a complex dirigible service to all the roadless and remote regions of the world. Under certain conditions this could considerably speed up the rate of cultural and economic development of these regions.

All these problems of the broad employment of dirigibles would have been generally recognized, and airships would have won public acceptance, if instances of breakdowns and disasters could have been reduced to a minimum.

This is confirmed by the fact that until 1935 the United States, Great Britain and other countries pursued extensive programs of dirigible construction, involving millions in investments. A major

reason for dropping these programs was doubt in the possibilities of successful operation of airships of the conventional rigid type, which do not always insure sufficient lift and constitute a fire hazard, especially when the gas employed is hydrogen. But this, of course, did not in itself reduce the demand for transportation of this kind.

World public opinion began to propose as the major requirements for dirigibles the conditions that had been formulated 40 years earlier by Tsiolkovski in nearly the same words (except that he did not mention helium), namely:*

- a) eliminate fire hazards by replacing inflammable hydrogen by a completely incombustible gas -- helium;
- b) improve the quality of the materials used in dirigible construction, use lightweight yet strong materials;
- c) improve the design so as to make it less vulnerable to extreme operating conditions;
- d) increase the load capacity while at the same time insuring freedom to select a route depending on the weather conditions;
- e) prolong the safe operating period of the dirigible;
- f) simplify operation and make dirigibles capable of parking aloft, tethered to mooring masts;
- g) reduce to a minimum the operating expenses, mainly gas leakages, which is particularly important on conversion from hydrogen to helium;
- h) investigate the operating conditions in all their aspects, so as to assure the complete safety of regular flights.

These severe requirements caused the leading designers to adopt a critical attitude toward the seemingly inviolable principles of designing giant airships based on the Zeppelin system. The de-

*See, e.g., Carl B. Fritchie, "The All-Metal Airship" in The Journal of the Royal Aeronautical Society, 1931. Russian translation published by ONTI in 1934.

signers began to realize that material was not being efficiently utilized: the frame of the airship was the only structural element; the remaining material (for example, gas ballonets and outer covering, which account for a large part of the dirigible's dead weight) did not add to the structural strength, the frame being left to carry the burden alone.

In endeavoring to eliminate this shortcoming and have all the elements of the airship participate in insuring its structural strength, the designers began to consider the advantages of building giant dirigibles with an all-metal hull.

The metal envelope fulfills the dual purpose of lending structural strength of the dirigible and serving as a gas container. This solution of the problem eliminates accessories such as the outer covering and the lifting gas ballonets, and it causes the entire envelope of the dirigible to react to the influence of gravity forces and aerodynamic loads.

On the whole, for a large dirigible this solution reduces the dead weight of the ship.

The successful design solution of this complex technical problem opened the way for the eventual construction of large-volume dirigibles with a much greater load capacity than the zeppelins and a longer range, higher operating ceiling, and a greater capability for nonstop flights.

The same problem could not be solved with small dirigibles and became very real once the advantages of using giant airships were recognized and airships with a volume of hundreds of thousands of cubic meters were built.

Thus, the advances in scientific understanding led back to the theories offered as early as the end of the last century by Tsiolkovskiy: it was recognized that only large airships could be advantageously used for transport purposes and that these airships should be all-metal (cf. Tsiolkovskiy's "200-Man Maneuverable Iron Aerostat").

Forty years of experimenting were needed to produce concepts that had already been expressed by K. E. Tsiolkovskiy, while aeronautics was still in the cradle.

As American designers have admitted, the advantages of dirigibles with a metal envelope consist in the following, as previously stated by Tsiolkovskiy:

*See, e.g., articles by the various engineers who participated in building the MC-2 dirigible, as edited by C. Fritchie in the journal "Aeronautical Engineering," 1931. A Russian translation by Zakharov was published under the title "Vozdushnoye sudno s metallicheskoj obolochkoj" (An Airship With a Metal Envelope), ONTI, Gosmashmetizdat, 1934.

1. A metal envelope can be made absolutely gastight; if filled with hydrogen, it will be free of the diffusion (usually observed in dirigibles with a fabric envelope) which may lead to the formation of a detonating mixture near the envelope; if, on the other hand, the ship is filled with a nonflammable gas like helium, the metal envelope will protect the gas against contamination and leakage, which is extremely important considering the high cost of helium.

2. The metal envelope of the dirigible makes it less susceptible to accidental damage and therefore more operational.

3. Such a dirigible will perform much better (compared with conventional dirigibles) when tethered to masts; moreover, it is not vulnerable to the weather and does not require servicing in hangars and shops during stop-overs en route.

4. Such a dirigible should be extremely economical and have a long life.

5. Such a dirigible should be safe for passengers, since weather conditions do not affect it, and it should be safer for over-seas flights than existing models.

Anyone who has ever read Tsiolkovskiy's works carefully will readily recall that he makes exactly the same suggestions.

Science and Technology were very late in grasping Tsiolkovskiy's concepts -- and by the time they grasped them, their author was forgotten and his name was not mentioned.

Work on metal-envelope dirigibles was begun in the USSR and United States, but for various reasons it had to be abandoned before the construction of the first models of large metal dirigibles could be completed.

As noted previously, K. E. Tsiolkovskiy claimed that the future belonged to ships that were both huge and made entirely of metal.

Tsiolkovskiy wrote that fabric airships could also be made completely maneuverable, but only metal airships could be safe.

Considering the complete impermeability of the metal envelope, K. E. suggested that the envelope itself should be directly filled with gas.

Tsiolkovskiy, as we know, did not confine himself merely to proposing a metal envelope. He worked out a theory of a "breathing" metal envelope, i. e., one capable of changes in volume depending on the behavior of the gas it contained; in addition, in order to insure the stable static equilibrium of the ship in flight without the aid of ballast, K. E. suggested heating the gas in the envelope and de-

veloped the theory of this problem.

Tsiolkovskiy's dirigible, if successfully tested, would have meant low-cost and simple dirigible production.

Despite all the attractiveness of the design and its indisputable operational advantages, the actual construction of a ship with a variable-volume envelope proved to be extremely difficult, even for the most advanced technology of the late twenties and early thirties.

The designers of metal dirigibles, both in the USSR and United States, started with a minimal program of improvements in dirigible building, this being simpler for the designers; thus, a variable-envelope dirigible was not contemplated.

Eventually, a metal-envelope dirigible, the MC-2, with a volume of 5600 m^3 , was built in the United States.

Since the dead weight of this small ship was so great (4150 kg) as to reduce its load capacity to almost zero, it must be regarded merely as a flying model of the future huge all-metal dirigible.

American designers did not attempt to apply the principle of Tsiolkovskiy's "breathing" envelope, but confined themselves to the scheme of a thin metal envelope reinforced by a lightweight metal framework of stringers and ribs. The envelope together with the framework represented a single structural unit, as in Tsiolkovskiy's dirigible.

The fixed shape of the American dirigibles and the maintenance of the required excess gas pressure inside the envelope were accomplished with the aid of ballonets in the form of fabric bags placed inside the metal envelope. In this case, the danger of an accidental mixing of the lifting gas with air inside the ship is eliminated by using the inert gas helium instead of the inflammable hydrogen.

Trials with this dirigible confirmed the assumption that metal-envelope dirigibles have considerable advantages.

The data on the operation of this dirigible were used as the basis for calculating the design of another, enlarged model ($200,000 \text{ m}^3$ volume).

The calculations confirmed both a saving in weight as compared with a zeppelin of the same volume, and a gain in speed. A decisive advantage of the metal-envelope dirigible, according to these calculations, was that the metal envelope can withstand a sharp rise in excess gas pressure; in fact, within certain limits, the overall structural strength of the ship even increases somewhat instead of decreasing. Therefore, the ship's captain can always increase the overall safety factor during forced and hazardous maneuvers by raising the excess gas pressure.

The design principle of this envelope makes full allowance for aerodynamic requirements and reduces drag to a minimum. Calculations

of large-volume dirigibles have shown that K. E.'s theories on the possibility of constructing a gastight metal envelope are definitely feasible, and that the maximum advantages of such an envelope can be

obtained only for ships with a volume of $100,000 \text{ m}^3$ and upward; in fact, the larger the volume the greater the advantages.*

This last conclusion merely echoes what Tsiolkovskiy had asseverated in the nineties and laid down in a number of his works.

A group of Soviet dirigible builders, engineers who ascertained through their own calculations that technical progress in dirigible building would depend on the development of a new type of metal-envelope dirigible, produced a complete design for a ship of this kind,

with a volume of 8000 m^3 , and carried out a number of related experiments.

This dirigible was also intended to be a large airworthy model of the future all-metal flying giants. But in this case, too, the only ideas of Tsiolkovskiy's to be utilized were his scientifically based concepts of the metal envelope as a load-bearing structure. As for the overall structural design of the new dirigible, it remained quite simple.

The envelope of this dirigible consisted of sheets of stainless steel 0.1 mm thick. The principal technological process used in constructing it and making the joints was electric welding, as recommended by Tsiolkovskiy. Compared with the riveting employed by the Americans, electric welding is more reliable, since the seams are stronger and more gastight, and the work goes considerably faster.

The problem of constructing the world's first stainless-steel dirigible was solved by the young and talented Soviet engineers completely on their own, using new materials and a new technological process. The ship's hull consisted of a lightweight frame to which the envelope was welded. Thus the entire hull was a load-bearing structure. The envelope, which lacked interior ballonets, served also as the gas container. No attempt was made to construct a variable-volume envelope and so, in order to insure a constant internal excess pressure in the envelope, two fabric air-ballonets were introduced; the air in them was delivered by a propeller. The successful progress of the work to develop this first Soviet metal-envelope

*This refers to the calculations of the designers of the dirigible ZMC-2, given in their articles in the journal "Aeronautical Engineering," 1931 (see footnote on p. 19).

dirigible confirmed all the original concepts and calculations of its designers.

All that had been done thus far in the USSR and United States was to solve a mere fraction of the complex of technical problems broached in Tsiolkovskiy's works. Not even a rudimentary attempt was made to translate into reality Tsiolkovskiy's calculations of the "breathing" envelope; that was still beyond the grasp of the dirigible engineers.

The ballonetless dirigible was doubtless a major stride forward in dirigible construction. K. E. Tsiolkovskiy, thanks to his rigorous calculations, provided a solution of this problem. As science and technology develop, other solutions may also arise.

Once the construction of transport dirigibles is resumed on a large scale, the final design of the all-metal ships will, of course, be adapted to the latest achievements of engineering science and based on analyses of the worldwide experience gained in the building and operation of dirigibles. By now, however, it may be confidently stated that as for the feasibility and economic expediency of building metal-envelope dirigibles, the principles first formulated by Tsiolkovskiy have completely passed the test.

It is absolutely certain that the future belongs to the dirigible that has a completely gastight envelope, is the least susceptible to weather conditions, the simplest to repair, easy to operate, optimal in design with respect to weight and, therefore, with a maximum load capacity and optimal flying and operating qualities. This ideal airship of the near future is a ballonetless dirigible with an all-metal hull and a variable-volume gas container, exactly as maintained by Tsiolkovskiy in all his works on dirigible construction.

Following their work with metal dirigibles in 1929-1930 the American dirigible builders advanced the concept that the best solution was a large dirigible with a metal envelope.*

As far back as 1890 Tsiolkovskiy had foreseen this trend and, in his calculations for a variable-volume metal envelope, he had already expressed this idea of the American designers. He had wholeheartedly striven to ensure the primacy of his compatriots in dirigible development.

The fundamental premises for judging the further prospects of dirigible building must be:

*For sources see footnotes on pp. 17, 19, 21.

- 1) a conviction that a given country must have dirigibles;
- 2) the technical feasibility of meeting the new high requirements for reliable dirigible operation.

The first premise exists. This was proved by the tremendous capital investments in dirigible construction made for many years in the United States, Great Britain, and Germany, by the efforts to refine dirigible design in building the R-100 and R-101 in Great Britain, the Akron and Macon in the United States, and the LZ-127 and LZ-129 in Germany, by the huge amount of related scientific research, and, lastly, by the construction of dirigible bases around the world.

For it cannot be doubted that, had not the last four giant dirigibles met with disaster,* had they accomplished the tasks for which they were designed, we now would have a vast network of dirigible lines linking the Old World with the New and the capitals of many countries with their former colonies; then, of course, the construction of dirigibles would not have been discontinued owing to their apparent superfluity or their apparently low level of technical qualities and airworthiness (ceiling, speed, cruising range, load capacity, etc.).

The cessation of dirigible construction does not in itself invalidate the first of these premises. In reality, the principal cause of this cessation was doubt in the structural reliability of large dirigibles, inability to find a workable technical solution that would protect the passengers against so-called flight accidents, and a lack of confidence in the interested countries in their own ability to cope with the rising difficulties of operating large-volume airships.

It is unquestionable that the problem of the further construction of transport dirigibles hinges on the solution of the technical problem of their safety.

Now the safety of dirigibles, in its turn, hinges on the need to improve the design of large dirigibles and the techniques of operating dirigibles, and also on the need to replace the inflammable

*Here we refer to: the British dirigible R-101, volume 148,000 m³ (crashed in 1930); the American Akron and Macon, volume 184,000 m³ each (crashed in 1933 and 1935); and the German Hindenburg, volume 20,000 m³ (crashed in 1937).

gas hydrogen by the inert gas helium as the lifting gas of the dirigible.

Scientific and technical concepts have advanced to a stage at which the obsolete large zeppelin-type dirigibles have been abandoned and the solution of the problem of the all-metal hull has begun to be explored along the path pointed out by Tsiolkovskiy. Here it is pertinent to quote K. E. Tsiolkovskiy concerning the way out of the impasse reached by dirigible construction: "Complete maneuverability can also be obtained with organic aerostats, but only metal airships assure safety and broad practical applications."*

IV. Recognition of the Works of K. E. Tsiolkovskiy. Their Historical, Scientific and Practical Value.

By the time of the Great October Socialist Revolution Tsiolkovskiy had reached the age of 60.

After the Revolution a tremendous change took place in K. E.'s life. Under Soviet rule he became surrounded with esteem and unflagging attention. His works received complete recognition.

The entire history of dirigible construction and a penetrating analysis of every improvement made in the dirigibles actually built led K. E. to conclude that there was no need to modify any of his concepts of the all-metal dirigible, and further convinced him of the validity of the conclusions and suggestions that he had offered since 1890.

The works of Tsiolkovskiy that date from the Soviet period repeat the principal assumption of his theory of the metal aerostat, provide counsel on the practical organization of experimental work, survey critically the existing types of dirigibles, and point out the errors in the research into metal-envelope dirigibles in the USSR and abroad.

In the final years of Tsiolkovskiy's life an engineering group was set up at the "Dirizhablestroy" Trust with the object of designing a ship along the lines he proposed. In 1933 this group was renamed

*K. E. Tsiolkovskiy. "Prostoye ucheniye o vozdushnom korable," Kaluga, 1904, p. 103.

the Bureau for Building the Tsiolkovskiy Dirigible, and provided with an experimental shop.

The first two steel models of the envelope, with volumes of 1 and 13 m^3 , yielded a great deal of information for elaborating the technological process and continuing the project.

In 1933 the Bureau designed an experimental flying model with a volume of 3000 m^3 , based on an outline sketched by Tsiolkovskiy a year previously. The research program provided for experimental investigations of different methods of joining steel sheets, the mechanical properties of corrugations, the strength of the joints between individual components, the behavior of complete envelope under variable loads, etc.

In addition, K. E. drafted a program that envisaged the construction of a number of models of progressively increasing size, with gradual refinement of the individual structural components.

Taking into account the desiderata stated by K. E. (see above), the Bureau designed in 1934, and built in 1935, a model with a

volume of 1000 m^3 that was the prototype of the envelope of the future Tsiolkovskiy all-metal dirigible.

During the construction and testing of this model the Soviet engineers verified the justice of K. E.'s principal postulates on such advantages of the all-metal ship as total gastightness, simplicity of design and construction, which reduced the entire process of envelope production and assembly to work with plane surfaces, the possibility of utilizing the engine exhaust gases to heat the lifting gas with the object of adjusting the lifting force of the dirigible in flight, etc.

The successes in working with this large model enabled the Bureau to develop broad research to the deeper aspects of the Tsiolkovskiy theory of dirigibles, to elaborate the design of individual elements and components of the dirigible, to master the technological process of production and assembly, to reorganize the production base, and to improve the training program.

The first period of Tsiolkovskiy's creativity (1886-1892), though characterized by an abundance of ideas and theories of fundamental value, which have not lost their relevance up to the present day, and some of which have even become most topical, could not, of course, be commensurate with the level of technical progress then prevailing, which was much lower than it is now.

Readers of Tsiolkovskiy's original works who are already familiar with the theory of the problem from the specialized literature of today and the writings of K. E. in the final period of his life will be interested to trace the progress in the ideas of this

self-educated scientist from elementary information about aerodynamics and certain other disciplines to problems of the theory of elasticity that still present considerable difficulty to the science of our own day.

A bold combination of advanced ideas in the field of physics and thermodynamics with strict requirements for the engineering industry enabled the author, as early as 1892, to propose an airship design that would be best and safest.

As raised by Tsiolkovskiy, such problems as heating the gas in the airship, utilization of the elastic properties of metal, and the like, are problems the complete solution of which still requires a great deal of work on the part of the scientists and engineers of the present and perhaps future generations.

Tsiolkovskiy's creativity in the field of the all-metal dirigible is of special value precisely now that the advocates of the old method of dirigible construction can see no way out of the difficulties they have encountered.

For so long as comparatively small dirigibles satisfied practical needs, Tsiolkovskiy's ideas were regarded as unnecessary. But now that previously adopted dirigible designs no longer satisfy the increased demands and high operating requirements, the only solution is to undertake studies of large dirigibles of the type that has not yet been realized.

Successful technical mastery of the principles of the Tsiolkovskiy dirigible would basically resolve all the difficulties that have recently been hampering the construction of transport dirigibles:

- 1) the all-metal envelope provides a container of maximum strength;
- 2) the variable volume of the envelope, which depends on the behavior of the gas inside the ship, dispenses with the complicating feature of air ballonets and assures the purity of the gas;
- 3) the heating of gas in the ship facilitates changes in altitude;
- 4) the optimal weight ratio of such a ship could raise the dirigible ceiling to 10,000 m.

The actual designing and subsequent construction of dirigibles require an extensive study of a series of new scientific and technical problems in the light of present-day science and engineering.

The problem of the lifting gas must be radically resolved; inflammable hydrogen must be replaced by helium.

Much work also remains to be done with respect to coordinating the creative activity of the designer with the needs of practical operation.

Even in his first work on aeronautics Tsiolkovskiy clearly foresaw the technology of the future and the future needs for aerial transport. He pointed out the path of development of dirigible construction for many years ahead. His work is now a shining beacon in science, attracting the attention of the scientists and designers called upon to provide mankind with a reliable transport dirigible.

I. THEORY OF THE AEROSTAT*

1. CONDITIONS FOR THE EQUILIBRIUM, ASCENT,
AND DESCENT OF THE AEROSTATBasic formulas

1. The forces acting on an aerostat can be divided under two principal headings. The first group of forces are those acting in the direction opposed to gravity, and accordingly lifting or striving to lift the aerostat. The magnitude of this lifting force is determined, on the basis of Archimedes' law, by the formula

$$Q_b = \gamma_a U,$$

where the letters denote respectively: the Archimedean buoyant force, the density of the air, and the volume of the aerostat.

*Writings of 1886; 1905 to 1908.

The asterisk (*) will be used to indicate editor's remarks found at the back of the book, or footnoted in the text.

2. The action of the other forces is aligned with the direction of gravity, and consists of the weight $Q_{st.}$ of the aerostat structure and the weight Q_g of the light gas carried in the aerostat balloon. The weight of the passengers, fuel, and any other cargo will be designated simply as Q_L . The sinking force $Q_{si.}$ will thus be expressed by the equation

$$Q_{si.} = Q_{st.} + \gamma_g \cdot U + Q_L$$

3. The relationship between the sinking force and the buoyant force on the aerostat determines the ascent, descent, and equilibrium of the aerostat. The equilibrium condition is expressed by the formula

$$Q_b = Q_{si.} = \gamma_a U = Q_{st.} + \gamma_g U + Q_L$$

or by

$$U (\gamma_a - \gamma_g) = Q_{st.} + Q_L$$

4. If this equation is not satisfied, the aerostat will neither rise nor descend. In that case the resultant R will be

equal to the following

$$R = Q_b - Q_{si} = (\gamma_a - \gamma_g) U - Q_{st.} - Q_L.$$

and will comprise the difference between the forces acting to buoy up or pull down the aerostat. When the resultant is positive, the aerostat will rise, and when it is negative the aerostat will descend, while, when the result is zero, the aerostat will be in equilibrium.

Effect of Temperature and Pressure
on Terms in the Above Formulas

5. The quantities appearing in our above equations are generally variables. Thus, the density of the air, the density of the gas, and the volume of the aerostat will depend on the temperature inside and outside the aerostat envelope, as well as on the pressure inside and outside the envelope, and these variables depend in turn on the climatic, meteorological, and other influences (for example, on the altitude of the aerostat above sea level).

6. We know from physics that the variations in the terms U , γ_a , and γ_g are expressed by the following functions of the absolute temperature T and the pressure p :

$$7. \quad \gamma_a = \gamma_{a0} \cdot \frac{p_a}{p_0} \cdot \frac{T_0}{T_a},$$

$$8. \quad \gamma_g = \gamma_{g_0} \cdot \frac{p_a}{p_0} \cdot \frac{T_0}{T_g},$$

$$9. \quad U = U_0 \cdot \frac{p_0}{p_g} \cdot \frac{T_g}{T_0},$$

since the density of any gas γ_g is proportional to the pressure p_g exerted on it and is inversely proportional to the absolute temperature T_g of the gas, while the dependence of the volume U of the gas on these variables is reciprocal.

10. In these formulas, p_0 denotes the pressure of the gas or air on a unit area at normal temperature (0°C) and normal pressure (760 mm Hg); U_0 is the volume of the entire gas under those conditions; T_0 is the absolute temperature zero, i.e., 273°K .

11. In general the absolute temperature is

$$T = t + 273,$$

where t is the centigrade temperature.

However, in these last formulas, we may infer any pressures, temperatures, volumes, and densities whatever, provided these quantities, e.g., T_0 , U_0 , γ_0 , and p_0 are properly interrelated, i.e.,

the volume U_0 must refer to the temperature T_0 , density γ_0 , and pressure p_0 .

12. Now, from equation (4), on excluding the variables with the aid of equations (7), (8), and (9), we find

$$R = U_0 \left[\gamma_a \left(\frac{p_a}{p_g} \right) \left(\frac{T_g}{T_a} \right) - \gamma_{g_0} \right] - Q_{st.} - Q_L.$$

13. Clearly, from this equation, the resultant R will not change in magnitude when the temperatures remain the same but the pressures vary while remaining mutually equal, as will occur when there is no obstacle to a change in the volume of the aerostat or when its envelope is free to change in volume. The resultant will not change either when the ratio p_a/p_g remains constant, i.e.,

when the external pressure is a certain number of times greater or smaller than the internal pressure, even though one or the other may vary without limit. This will be the case whenever the volume of the aerostat or of the gas filling it is artificially varied and the pressure of the internal gas is thereby altered as well. Such a case is seemingly of no practical importance.

14. The resultant will likewise suffer no change in response to a change in the temperature, provided the temperatures inside and outside the aerostat are equal; this situation will prevail both day and night in overcast weather with the aerostat remaining at a fixed altitude above sea level. The resultant will not change either when the temperatures inside and outside are different, but the ratio of the absolute temperatures T_g/T_a remains unchanged. This

case may apply to any aerostat.

15. Finally, the resultant will remain unchanged even when the pressures and temperatures are different but the ratios p_a/p_g and T_g/T_a are constant, or when the ratio of the products

$p_a T / p_g T$ is constant. Note that, from formulas (7) and (8), we may infer

$$16. \quad \frac{\gamma_a}{\gamma_g} = \frac{\gamma_{a_0}}{\gamma_{g_0}} \cdot \left(\frac{p_a T_g}{p_g T_a} \right) .$$

Accordingly, in place of this last condition of constancy of the resultant we may adopt another: a constant R requires that the ratio between the air and gas densities γ_a / γ_g remain unchanged.

The Walls of the Aerostat May Be Freely
Compressed and Expanded

17. In an aerostat such as described, the external pressure p_a of the atmosphere may be assumed equal to the internal pressure p_g of the gas; formula (12) will then take on the form:

$$R = U_0 \left[\gamma_{a_0} \left(\frac{T_g}{T_a} \right) - \gamma_{g_0} \right] - Q_{st.} - Q_L .$$

18. Clearly then, the resultant R will retain its value when the ratio of the absolute temperatures $\frac{T_a}{T_g}$ is constant, no matter

$$T_g$$

how the pressure of the air and gas change in the process, the same therefore applying to the volume of the gas or of the aerostat.

19. Since $\frac{T_g}{T_a} = 1 + \frac{T_g - T_a}{T_a}$, a constant resultant may be

dictated by a constant ratio $\frac{T_g - T_a}{T_a}$, i.e., by a constant ratio of

the temperature difference inside and outside the aerostat to the absolute temperature of the air.

20. For example, let the centigrade temperature of the air be successively: 0° , 5° , 10° , 15° , 20° , 25° , 30° , 35° , 40° (the absolute temperature will be higher by 273°). Let the temperature of the gas be 10° higher initially or at 0°C ; then this temperature difference will rise in response to an increase in the air temperature, but negligibly, if the resultant is to remain the same:

namely, it will successively increase as follows: 10.0° , 10.2° , 10.4° , 10.6° , 10.7° , 10.9° , 11.1° , 11.3° , 11.5° .

21. When the temperature of the air decreases, the temperature difference must likewise decrease negligibly.

The temperature of the atmosphere surrounding the aerostat may thus fluctuate to great extremes but the difference in the temperatures will fluctuate by only a slight amount if the resultant is to remain constant.

In view of the foregoing, we find for a constant resultant:

$$\frac{T_g - T_a}{T_a} = \text{const};$$

whence, we may readily calculate the difference $T_g - T_a$ at various given T_a , as we indeed have just done.

22. The simplest case is obtained when not only the pressure inside and outside is the same, but when even the temperatures are equal, or the temperature difference is zero.

Then equation (17) or (12) will state

$$R = U_0 (\gamma_{a_0} - \gamma_{g_0}) - Q_{st.} - Q_L.$$

23. This equation includes neither temperature nor pressure, so that we may state: the temperature and the pressure have no effect on the resultant: on either its sign or its magnitude.

Consequently, if an aerostat which is free to change its volume gains altitude, then it will continue gaining altitude indefinitely under the action of a constant force; if it is losing altitude, then it will also descend with a constant force; if equilibrium is maintained ($R = 0$), then the equilibrium will not be impaired when either the temperature or the pressure or both together undergo any kind of changes or when the aerostat is carried by some stray force into a medium where the temperature and pressure are completely different, provided the temperature of the air medium is no different from the temperature of the gas enclosed in the aerostat envelope.

24. All this is valid, as we saw (21), even in the case of unequal temperatures, provided the difference $T_g - T_a$ varies slightly in accord with the variation in the air temperature; when it rises, the difference must rise slightly, and when it drops the difference must drop likewise. This is expressed more exactly in paragraphs 18 and 19.

25. When the volume of the aerostat changes freely under the pressure of a light gas, we then have formula (17) for the resultant. We can easily obtain the changes in the buoyant force on the aerostat in response to slight changes in the temperatures of the gas and air by differentiating equation (17):

$$dR = U_0 \gamma_{a_0} \frac{T_g}{T_a} \left(\frac{\partial T_g}{T_g} - \frac{\partial T_a}{T_a} \right).$$

26. Hence, as the temperature of the gas rises the buoyant force increases in proportion, while as the temperature of the air rises the buoyant force slackens. It is clear that the pressure of the atmosphere, when equal to the pressure of the internal gas, will have no effect whatever on the magnitude of the resultant.

27. We derive from formulas (1), (7), and (9) the following equation for the buoyant force Q_b

$$Q_b = \gamma_{a_0} U_0 \frac{T_g}{T_a} \cdot \frac{p_a}{p_g}.$$

28. But as a result of the free expansion of the aerostat, $p_a = p_g$, so that formula (25) may be restated as:

$$dR = Q_b \left(\frac{\partial T_g}{T_a} - \frac{\partial T_a}{T_a} \right).$$

29. It is readily seen, then, what the ratio of the increment in the buoyant force dR is to its total magnitude Q_b . For example, if the absolute temperature of the gas and the air is the same initially, say, 300° (or $273^\circ + 27^\circ$), and were then to increase by 1° , then the relative increase in buoyant force in the case where

the temperature of the gas rises would be $1/300$. At the same increase in the air temperature, the relative decrease would be $1/300$.

30. The invariability of the buoyant force is dictated by the equation

$$\frac{\partial T_g}{T_g} = \frac{\partial T_a}{T_a}, \quad \text{or} \quad \frac{\partial T_g}{\partial T_a} = \frac{T_g}{T_a},$$

arrived at by setting the second part of equation (28) equal to zero.

31. The temperatures of the air and the gas vary naturally each second. If this change occurs simultaneously and to the same extent for the gas and for air, or obeys condition (30), then this change could not affect the magnitude of the resultant, or thereby the equilibrium of the aerostat. Equal temperatures inside and outside the aerostat will usually be found in daytime and at night in overcast weather.

32. Otherwise, the temperatures will be different and will not obey the rigorous law (30). The difference between the temperatures of the gas and of the air will depend on the clearness of the daytime sky, on the cloudiness, on the height of the sun, on the position of the aerostat relative to the direction of the sun's rays, on the state of the surface on the aerostat envelope, on the extent to which the envelope is covered by snow or moisture. At daytime in a clear sky, the temperature of the gas will be in general 20 degrees higher because the sun will be heating up the envelope. The temperature difference will also be affected by the speed of the independent horizontal motion of the aerostat, as well as by its rate of ascent or descent.

33. At night in a clear sky, the gas temperature will be lower, in general, than the temperature of the surrounding air,

which will depend on the cooling of the envelope by radiation. This difference will also depend on clearness of the sky, on the cloud cover, on the state of the aerostat envelope, on how close the aerostat is to the earth's surface, on the state of this surface or its temperature (a factor which is also important in the daytime), on the motion of the aerostat, etc.

34. Clearly then, both at daytime and at night, unless exceptional conditions occur, the buoyant force on the aerostat, or the resultant, must change continuously. Thus the equilibrium of the airship as achieved by the load and ballast on board, is continually challenged by meteorological and topographic influences, so that the height of the aerostat above sea level must be subject to constant change.

35. But we can counteract all of these effects harmful to the equilibrium of the airship, by adjusting the gas temperature. To this end, the temperature T_g of the gas is maintained artifi-

cially far above the temperature of the air surrounding the aerostat. When required, the temperature of the gas can be lowered by reducing the inflow of heat from inside the aerostat, or can be increased still further by increasing the inflow of heat. We thereby achieve a constant ratio T_g / T_a , and accordingly a con-

stant resultant R_g . If the resultant R is zero, then, the aerostat will maintain an equilibrium despite meteorological and other effects.

Volume of Gas or Volume of Aerostat May Not Change

36. Suppose that the volume of the gas repository can be neither increased nor decreased. The first will be the case when the aerostat is filled to capacity; the second will occur at the same time whenever the walls of the gas repository resist any force moving them closer together because of the rigidity of the walls, the thickness of separating partitions, etc.

This case will be encountered most frequently when the pressure inside the envelope is considerably higher than the pres-

sure outside.

Then the internal pressure of the gas will hinder any decrease in the aerostat volume, up to a point.

From formula (4) we find

$$R = \gamma_a U - \gamma_g U - Q_{st.} - Q_L.$$

37. In the equation, only two variables are present: R and γ_a . Therefore the increment Δ in the resultant will be:

$$\Delta R = U \Delta \gamma_a.$$

Consequently, the resultant will increase with any increase in the density of the air surrounding the aerostat.

38. Assume for instance a zero resultant R , i.e., the aerostat is assumed to be at equilibrium.

Then this equilibrium may be impaired through the following causes:

a) an increase in the density of the air surrounding the aerostat, so that the aerostat will climb until the density has decreased by the same amount $\Delta \gamma_a$;

b) a decrease in the density of the air, so that the aerostat will descend to a layer of air having the original density.

39. The foregoing may be expressed as a function of a change in the air temperature and air pressure.

By differentiating equation (7), we find

$$d\gamma_a = \gamma_{a0} \frac{T_0}{T_a} \cdot \frac{p_a}{p_0} \left(\frac{\partial p_a}{p_a} - \frac{\partial T_a}{T_a} \right).$$

Clearly, any increase in the barometric pressure (with the temperature remaining the same) means that the air density, and consequently also, the resultant will also increase, so that the aerostat will have to climb if it was in equilibrium before then.

As the air temperature increases, the air density and consequently also the resultant will have to decrease, so that the aerostat will have to lose altitude, if it was in equilibrium before then. A decrease in the temperature will bring about the opposite effect.

40. When the air temperature and air density vary simultaneously, the equilibrium will be impaired, provided that condition (39)

$$\frac{\partial p_a}{p_a} = \frac{\partial T_a}{T_a},$$

is satisfied, i.e., the relative temperature and pressure increments must be the same.

When the pressure increases and the temperature decreases, it is readily seen that the resultant will undergo a double increment.

41. On the basis of equation (7), formula (39) transforms to:

$$d\gamma_a = \gamma_a \left(\frac{\partial p_a}{p_a} - \frac{\partial T_a}{T_a} \right),$$

and, on multiplying both parts of the equation by the volume U , we find

$$U d\gamma_a = U \gamma_a \left(\frac{\partial p_a}{p_a} - \frac{\partial T_a}{T_a} \right).$$

On the basis of equation (1), then, we may state: the relative increment in the buoyant force compared to the total buoyant force is expressed by the formula

$$\frac{U d\gamma_a}{U \gamma_a} = \frac{dQ_p}{Q_p} = \frac{\partial p_a}{p_a} - \frac{\partial T_a}{T_a}.$$

42. We refer to the pressure p_a of the air surrounding the aerostat. But this pressure is not the same on all parts of the aerostat. It is lower on the top of the aerostat than on the bottom. p_a may be taken to mean the average pressure on the aerostat. Moreover, the pressure of the internal gas also cannot be considered the same on different parts of the interior of the aerostat, since this pressure will depend on the extent to which the envelope has been filled. Therefore, our statements on an aerostat having a freely

varying volume are not quite exact.

The pressure outside (p_a) may be only approximately equal to the pressure inside (p_g). Even a completely filled and blown-up aerostat could not retain its volume unchanged, strictly speaking, despite any changes in the pressure difference inside and outside the aerostat.

All of this discussion makes it clear that our earlier formulas fall short of being ideally exact. They represent no more than one step toward the recognition of certain truths. A second step may bring us still closer to those truths, but our formulas will then have become much more complex.

43. To complete the picture, we presented here also formulas referring to an aerostat which undergoes no change in volume, but such an aerostat cannot withstand criticism in actual practice. In fact, an aerostat fitting that description would have to be inflated up in such a manner that the gas pressure inside would considerably exceed the external air pressure. This pressure difference would require an unusually tough envelope. Moreover, any increase in that difference because of an increase in the internal temperature and because of a decrease in the barometric pressure (or because of the ascent of the aerostat) will contribute to the rupture of the envelope or, in the best case we can hope for, to a loss of gas from the envelope.

Constancy of the gas volume will also deprive the aerostat of the ability to vary its buoyant force or to maintain its equilibrium by varying the temperature of this gas without losing ballast and gas.

II. VARIATION IN AEROSTAT VOLUME

44. In practice, the aerostat cannot increase its volume without bound, and we will therefore determine precisely to what extent this volume must be increased as a result of the forces acting on the ground and in flight. This is very important, for ignorance of the extent of expansion of the gas enclosed in the balloon may entail the rupture of the balloon or a loss of gas -- when the safety valve is operating properly.

45. If the volume of the gas is U_0 when the absolute temperature of the gas is T_0 and the pressure is p_0 , while at a different temperature the absolute temperature of the same gas is T and the pressure is p , the volume of the gas is U , we will have, on the basis of the familiar properties of gases

$$\frac{U}{U_0} = \frac{T}{T_0} \cdot \frac{p_0}{p} .$$

This formula shows what portion of the total volume U_0 of the aerostat must be filled as the quantities T_0 and p_0 change to T and p .

If the temperature of the gas and the pressure on the gas do not vary, then it would be more sensible to fill the aerostat with gas to the very limit possible without rupturing the balloon. But the gas pressure and gas temperature may vary owing to meteorological factors and artificial causes, and hence also during ascent.

Equal Gas and Air Temperatures

46. Consider the effect of the barometric pressure. Barometric fluctuations increase poleward from the Earth's equator; but even at latitude 65° they will not attain 75 mm. Hence,

$$\frac{p_0}{p} > \frac{720}{795} = 0.9057.$$

Accordingly, for that reason we can fill up only $9/10$ of the volume of the aerostat, assuming a constant temperature.

47. The effect of the temperature is much more striking.

The lowest cold temperature recorded on the surface of the earth was -55°C ; the highest air temperature in the shade, $+47^{\circ}\text{C}$. The amplitude exceeds 100° . The ratio of the absolute extreme temperatures will be:

$$\frac{T}{T_0} = \frac{273 - 55}{273 + 47} = 0.680.$$

This means that only about $2/3$ of the greatest volume of the gas repository could be filled up for that reason.

48. Taking both factors into account in our calculations, we find

$$\frac{U}{U_0} = 0.618,$$

i.e., slightly more than $3/5$ of the entire volume.

49. Clearly then, the aerostat cannot be filled up once and for all for all the variations in temperatures and pressures, as this will be too inexpedient at high pressures and low temperatures. Actually, even though the buoyant force were to remain constant the whole time, it would have to be at its maximum. The above does not imply that the relative amount of the gas involved in filling up the balloon must comprise $3/5$. This quantity is, of course, dependent on both the temperature and the pressure during the filling-up process.

If we introduce, in place of T in formula (45), the maximum temperature T_{\max} , and in place of p_0 the minimum pressure p_{\min} , we shall then have

$$\frac{U}{U_0} = \frac{T}{T_{\max}} \cdot \frac{p_{\min}}{p_0}.$$

This equation indicates the relative extent to which the aerostat is filled at temperature T and pressure p .

50. For example, $T_{\max} = 47^\circ\text{C}$, $p_{\min} = 730$ mm Hg; now we fill up the aerostat at 0°C and at pressure 760 mm Hg; we then find

$$\frac{U}{U_0} = \frac{273}{47 + 273} \cdot \frac{730}{760} = 0.82,$$

or the aerostat must be filled to roughly $4/5$ of the total volume.

Constant Resultant Force

51. We did not take into account heating of the aerostat by sunlight and its cooling by radiation, such that the temperature of the aerostat will not be equal to the air temperature.

But we did see that, by regulating the temperature inside the aerostat, we could achieve a constant resultant (4) or, in other words, a constant buoyant force (1).

From formula (1), we find $U = \frac{Q_b}{\gamma_a}$, where the buoyant force

Q_b is conditionally a constant.

This means that the volume will vary in inverse proportion to the density of the air surrounding the balloon.

52. Eliminating γ_a from this last formula by means of equation (7), we obtain

$$U = \frac{Q_b}{\gamma_{a0}} \cdot \frac{p_0}{p_a} \cdot \frac{T_a}{T_0},$$

or the dependence of the volume on the change in the temperature T_a and on the pressure p_a .

In the course of several hours of flight, the air temperature, and in particular the air pressure (the barometer reading), could not have time to change very much.

Thus, when the temperature is being regulated, the change in aerostat volume will be dependent solely on those very slowly varying conditions, and not on the heating by the sun, shading by clouds, cooling at nighttime, or other factors.

53. By differentiating this last equation with respect to the variables T_a and p_a , we obtain

$$dU = \frac{Q_b}{\gamma_{B_0}} \cdot \frac{p_0}{p_a} \cdot \frac{T_a}{T_0} \left(\frac{\partial T_a}{T_0} - \frac{\partial p_a}{p_a} \right).$$

54. By means of equation (52), we may eliminate the buoyant force Q_p from this equation; we then obtain

$$\frac{dU}{U} = \frac{\partial T_a}{T_a} - \frac{\partial p_a}{p_a},$$

hence the relative change in the volume is expressed by the relative change in the temperature minus the relative change in pressure; for example, at 0°C (273°), a 10°C increase in temperature will bring about a relative change in volume by $10/273$, or about $1/27$. A decrease in pressure by 10 mm Hg at an initial pressure of 760 mm Hg will bring about a further change in volume by $1/76$.

Vertical Movements of the Aerostat
As a Cause of Changes in Its Volume

55. A still greater change in the volume of the gas accompanies the ascent or descent of the aerostat, which must be performed for a variety of reasons. For example, in flying over mountains, in hovering over both high and low points on the earth, in catching up with a favorable air current and favorable temperature conditions, it is sometimes advantageous, and sometimes imperative, for the airship to perform vertical movements.

Let us determine the relationship between the height H of the point above sea level, the temperature, pressure, and the rarefaction or density of the air at that point.

56*. Everyone knows that the temperature of the air decreases as the elevation above sea level is increased. But the law obeyed by this change in temperature has yet to be discovered. It is supposed, on the basis of observations, that the drop in temperature is more or less proportional to the height attained and is

about 5°C per km of ascent. The drop in temperature with elevation and vice versa can be explained in various ways.

57. From the standpoint of the mechanical theory of heat, gas molecules accelerate on moving downward, so that the temperature of the gas increases. The speed is lessened in the opposite direction because of the effect of the earth's attraction, and this corresponds to a decrease in the temperature. Calculations show that the extent to which the heat diminishes will be proportional to the elevation of the place and will be independent of the oscillation amplitude of the gas molecules, while the extent of this decrease will be proportional to the molecular weight of the gas.

58. Thus, we find for oxygen about 10°C per km of ascent, for for hydrogen (were our atmosphere a hydrogen atmosphere) a change of 16 times less, i.e., less than 1°C per km.

These calculations are not entirely justified, since the sun does not heat the upper and lower layers of air uniformly. The temperature nonuniformity will have to increase still further on that account. Moreover, these calculations are further invalidated by the fact that the lower layers of air and the surface of the earth itself tend to continuously heat by radiation the upper, less heated, layers. The ether waves tend to reestablish the temperature equilibrium disturbed by the incessant action of gravity on the falling and rising air molecules.

For the same reason, the theoretical law of decrease in temperature in proportion to ascent, and the amount of that decrease at 10°C per km of ascent, is also not entirely justified.

The cloud layers, the differing degree of air humidity, and a host of other factors render this law of temperature decrease capricious and elusive, like the weather itself.

59. The rise in the temperature of the earth as one proceeds deeper down into the earth, could also be explained from this standpoint. The molecular weight of the complex terrestrial rocks is far greater than that of air, so that the temperature drop must be far more pronounced. For example, take aluminum oxide or alumina, Al_2O_3 . Its molecular weight is 102. The molecular weight

of the oxygen molecule O_2 is 32, on the other hand; thus we see that

the weight of oxygen is only one-third that of alumina, so that the rise in the temperature of alumina will be three times greater than the rise in the temperature of the atmosphere, i.e., about 30°C per km; this is validated almost exactly: the heat conduction of fragmented soil particles is very small, and therefore the lower

heated layers heat the upper layers only very slightly.

60. But let us return to air. We may use another point of view to account for the law of temperature decrease with elevation.

The temperature drop depends on the absorption of heat by the air as a result of the work done in gaining altitude and in expansion. The air has not only horizontal motion, but also vertical motion, which must be accompanied by compression and expansion, and consequently also by the heating and cooling of the air.

61. If we accept this alone as a basis, and assume that the upper layers are not heated by radiation from the warm lower layers and from other causes, we may arrive again, theoretically, at the earlier law, and at the same coefficient of 10°C .

We now have $\frac{U}{U_1} = \frac{\gamma_1}{\gamma}$, where one and the same mass of gas initially has volume U_1 and density γ_1 , but later a volume U and a density γ .

62. Further, designating the heat capacity of the gas with volume held constant, or its specific heat, as c_v , and the mechanical equivalent of heat as M_e , we find, on the basis of the law of conservation of energy

$$pdU = - U_1 \gamma_1 c_v \frac{1}{M_e} dT.$$

Here p is the pressure of the gas or the pressure per unit area at a volume U and absolute temperature T .

63. But

$$p = p_1 \cdot \frac{T}{T_1} \cdot \frac{U_1}{U};$$

and here p_1 corresponds to U_1 and T_1 .

Accordingly,

$$\frac{p_1}{U} \cdot \frac{T}{T_1} dU = - \gamma_1 c \frac{1}{v M_e} dT,$$

or, separating the variables, we find

$$64. \quad \frac{dU}{U} = - \frac{\gamma_1}{p_1} c \frac{1}{v M_e} T_1 \frac{dT}{T}.$$

Putting $\frac{\gamma_1}{p_1} c \frac{1}{v M_e} T_1 = \text{const}$, we now find

$$65, \quad - \text{const} \cdot \frac{dT}{T} = \frac{dU}{U}.$$

Integrating this equation and determining the constant of integration, we arrive at

$$66. \quad \text{const} \cdot \ln \left(\frac{T_1}{T} \right) = \ln \left(\frac{U}{U_1} \right);$$

from the last formula, we obtain in turn:

$$\frac{U}{U_1} = \left(\frac{T_1}{T} \right)^{\text{const}} \quad \text{and} \quad \frac{T}{T_1} = \left(\frac{U}{U_1} \right)^{\frac{1}{\text{const}}}$$

68. Formulas (67) enable us to find the decrease in the air temperature according to the given rarefaction $\frac{U}{U_1}$ of the air,

and vice versa. Assuming the atmosphere to consist of some "constant" gas, we note that the value of the const in equation (64) will remain a constant in accord with the familiar properties of gases. Actually, for a known p_1 the density γ_1 and specific heat c_v of the gas will depend on the nature of the gas, but the product $\gamma_1 c_v$ will nevertheless remain constant.

Clearly, hence, the degree of cooling accompanying the expansion of a constant gas will not be dependent upon the nature of the gas; the same holds for the heating attendant upon compression.

69. Since we have $\frac{U}{U_1} = \frac{p_1}{p} \cdot \frac{T}{T_1}$, we find, on the basis of

formula (67)

$$\frac{T}{T_1} = \left(\frac{p T_1}{p_1 T} \right)^{\frac{1}{\text{const}}},$$

whence

$$70. \quad \frac{T}{T_1} = \left(\frac{p}{p_1} \right)^{\frac{1}{1+\text{const}}}.$$

71. Now, on imagining a vertical column of air endowed with weight, we can set up the following differential equation to express the fact that the increase in pressure on the column is proportional to the increase in the mass of the column and to the acceleration due to gravity g :

$$-dp = \gamma_1 \frac{p}{p_1} \cdot \frac{T_1}{T} \cdot g \cdot dH.$$

Here dH is the differential of the height H of the column of air, g is at 45° latitude, and is unity according to Laplace. On other latitudes, according to this scientist, we shall have

$$g = 1 - 0.002552 \cos 2\varphi,$$

where φ is the latitude of the point in question¹.

72. In place of equation (71), we may find, on the basis of formula (70), the equation

$$\frac{-\text{const}}{1+\text{const}} \frac{dp}{p} = \gamma \frac{p}{p_1} \frac{-\text{const}}{1+\text{const}} \cdot dH.$$

Integrating this equation and determining the integration constant, we find

$$73. \quad H = \frac{\text{const} + 1}{\gamma_1 g} p_1 \left[1 - \left(\frac{p}{p_1} \right)^{\frac{1}{1+\text{const}}} \right].$$

$$74. \quad \text{Here } \text{const} + 1 = 3.441 \quad \text{and} \quad \frac{1}{1 + \text{const}} = 0.2906.$$

¹Here we do not take into account the decrease in gravity with height. This decrease amounts to about 1/600 in an ascent 5 5 km. At higher altitudes, the decrease in gravity cannot be disregarded.*

*All numbered footnotes are the author's. (Edit.)

The height corresponding to p_1 and γ_1 is assumed to be zero.

75. From (73), we obtain

$$\frac{p}{p_1} = \left[1 - \frac{H\gamma_1 g}{(\text{const} + 1)p_1} \right]^{1+\text{const}}$$

Hence and from (70), eliminating the ratio p/p_1 , we find

$$76. \quad \frac{p}{p_1} = 1 - \frac{\gamma_1 g}{(\text{const} + 1)p_1} \cdot H \cdot$$

From this equation, with the aid of formulas (75), (63), and (61), we compute

$$\frac{\gamma}{\gamma_1} = \frac{U_1}{U} = \frac{p_1^T}{p_1^T} = \left[1 - \frac{\gamma_1 g \cdot H}{(\text{const} + 1)p_1} \right]^{\text{const}}$$

78. Formula (76) may be stated as:

$$T - T_1 = \frac{-\gamma_1 g T_1}{(\text{const} + 1) p_1} \cdot H .$$

Clearly, from this formula, the temperature decrease is proportional to the height H , the acceleration due to gravity g , and the gas density γ . And since the density is proportional to the molecular weight and inversely proportional to the specific heat c_v ,

the temperature decrease will be inversely proportional to the specific heat of the gas and directly proportional to its molecular weight. We stated this last point earlier in general terms, even in reference to terrestrial rocks.

From equation (77), it is clear likewise that the degree of rarefaction U/U_1 of the atmosphere depends not only on the height of the place, but also on the acceleration due to gravity and on the gas density γ .

79. For $H = 1000$ meters, using formula (78) we calculate a temperature decrease of 12.8°C .

If we assume that parts of the atmosphere feature rapid vertical movements, with the lower warm layers failing to heat by radiation the upper cold layers and with the sun and other factors having no effect on the temperature of the air, then the thermal state of the air and the degree of rarefaction will be expressed as functions of the altitude by these last formulas.

Conversely, if we assume the temperature of the air to be constant, then we can easily derive Laplace's formula, but not the complete formula. If we assume, on the basis of observations, that the temperature decrease is proportional to the height, then we can make a correction, which in theory will be inexact, in that formula by assuming the height H to be proportional to the average absolute temperature. Then we shall obtain the complete Laplace formula.

Even though we derived the temperature decrease of 10°C per km of ascent distance theoretically, this is still not in agreement with reality, for the reasons explained above.

Thus, Coxwell found an average temperature decrease of 4°C per km in his air travels. Biot and Gay-Lussac found 6°C , Sessure found 7°C in this ascent to Mont Blanc, and Humboldt found only 5°C .

In general, experimental findings more or less confirm the view that the temperature decrease is proportional to the height of ascent, but the actual extent of this decrease proves to be half that which we calculated. It follows that the temperature decrease due to vertical movements and the temperature increase due to radiation and other causes are, as it were, two equal forces yielding an average temperature difference of 5°C .

80. We therefore assume in formula (78) a multiplier η less than unity and close to 0.5, and we put

$$T - T_1 = \frac{-\eta\gamma_1 g T_1}{(\text{const} + 1)p_1} \cdot H,$$

or

$$81. \quad \frac{T}{T_1} = 1 - \frac{\Delta t}{H} H,$$

where $\frac{\Delta t}{H}$ denotes the temperature gradient, so that

$$82. \quad \frac{\Delta t}{H} = \frac{\eta\gamma_1 g}{(\text{const} + 1)p_1} .$$

Clearly, $\frac{\Delta t}{H}$ expresses the relative temperature decrease per unit of H.

We now set up a differential equation similar to (71). Eliminating T/T_1 in this equation by means of (81), and separating the variables, we obtain

$$83. \quad \frac{dp}{p} = \frac{\gamma_1 g dH}{p_1 (1 - \frac{\Delta t}{H})} .$$

On integrating this equation, we find

$$84. \quad \ln \left(\frac{p}{p_1} \right) = \frac{\gamma_1 g}{p_1 \Delta t H} \ln (1 - \frac{\Delta t}{H}) .$$

Whence, on eliminating $\frac{\Delta t}{H}$ by means of equation (83), we find

$$85. \quad \frac{p}{p_1} = \left[1 - \frac{\eta \gamma_1 g}{(\text{const} + 1) p_1} \cdot H \right]^{\frac{\text{const} + 1}{\eta}} ;$$

and then, according to formulas (61), (63), (80) and this last equation, we arrive at

86.

$$\frac{U_1}{U} = \frac{\gamma}{\gamma_1} = \frac{p}{p_1} \cdot \frac{T_1}{T} = \left[1 - \frac{\eta \gamma_1 g}{(\text{const} + 1) p_1} \cdot H \right]^{\frac{\text{const} + 1}{\eta}} - 1.$$

87. In order to check our formulas and also to show whether or not the Laplace formula features complete exactness, we will derive it from equation (85).

On determining the height, we find from that equation:

$$H = \frac{(\text{const} + 1) p_1}{\eta \gamma_1 g} \left[1 - \left(\frac{p}{p_1} \right)^{\frac{\eta}{\text{const} + 1}} \right],$$

or, on the basis of (82)

$$H = \frac{1}{\Delta t_H} \left[1 - \left(\frac{p}{p_1} \right)^{\frac{\eta}{\text{const} + 1}} \right].$$

88. If we expand the exponential function in this last formula into a series, we obtain

$$\begin{aligned}
H &= \frac{1}{\Delta t_H} \left\{ \frac{\eta}{\text{const} + 1} \cdot \ln \left(\frac{p_1}{p} \right) + \frac{1}{1 \cdot 2} \left[\frac{\eta}{\text{const} + 1} \cdot \ln \left(\frac{p_1}{p} \right) \right]^2 + \right. \\
&+ \frac{1}{1 \cdot 2 \cdot 3} \left[\frac{\eta}{\text{const} + 1} \cdot \ln \left(\frac{p_1}{p} \right) \right]^3 + \frac{1}{1 \cdot 2 \cdot 3 \cdot 4} \left[\frac{\eta}{\text{const} + 1} \cdot \ln \left(\frac{p_1}{p} \right) \right]^4 + \dots \left. \right\} = \\
&= \frac{\eta}{\Delta t_H (\text{const} + 1)} \cdot \ln \left(\frac{p_1}{p} \right) \left\{ 1 + \frac{1}{2} \left[\frac{\eta}{\text{const} + 1} \cdot \ln \left(\frac{p_1}{p} \right) \right] + \right. \\
&+ \frac{1}{3} \left[\frac{\eta}{\text{const} + 1} \cdot \ln \left(\frac{p_1}{p} \right) \right]^2 + \frac{1}{3 \cdot 4} \left[\frac{\eta}{\text{const} + 1} \cdot \ln \left(\frac{p_1}{p} \right) \right]^3 + \dots \left. \right\} .
\end{aligned}$$

The expression in brackets with the multiplicative factor $1/\Delta t_H$ is approximately the height H . We therefore write:

$$H = \frac{\eta}{\Delta t_H (\text{const} + 1)} \cdot \ln \left(\frac{p_1}{p} \right) \left(1 + \frac{\Delta t_H}{2} \cdot H \right)$$

or, in accord with (82):

$$H = \frac{p_1}{\gamma l g} \cdot \ln \left(\frac{p_1}{p} \right) \left(1 + \frac{\Delta t_H}{2} \cdot H \right) .$$

89. On the basis of (81), we see that $\frac{\Delta t}{H}$ expresses the relative decrease in temperature per unit of ascent distance, i.e.,

$\frac{\Delta t}{H} = \frac{\Delta t}{T_1}$. The product $(\frac{\Delta t}{H} \cdot H)$ will be the total relative decrease in temperature with ascent to a height H . Consequently, we may restate the formula as:

$$H = \frac{p_1}{\gamma_1 g} \cdot \ln \left(\frac{p_1}{p} \right) \left(1 + \frac{\Delta t}{2T_1} \right).$$

Here Δt is the temperature difference of the two localities, and T_1 is the absolute temperature of the locality of the lesser altitude.

The nature of this formula is almost the same as that of the Laplace formula; it shows that the height H is inversely proportional, and is directly proportional to the mean absolute temperature of the column of air. But there is a slight numerical difference in the determination of the height, which is quite understandable, since only Regnaud, long after Laplace, gave sufficiently exact coefficients of expansion of gases, and thereby made it possible to determine the absolute temperature T_1 .

90. We can also restate formula (89) in a completely Laplacian form. Actually, we find from equation (82):

¹Gay-Lussac found the number 0.00375 for the expansion coefficient, a figure later confirmed by Dulong and Petit. Dalton arrived at almost the same value. Rydberg obtained 0.00365, and Magnus arrived at almost the same. Regnaud obtained about 0.00366. We have adopted this last figure, of Regnaud.

$$\Delta t_H \cdot H = \frac{T_1 - T}{T_1}.$$

But since $T_1 = 273 + t_1$ and $T = 273 + t$, where t_1 and t are the usual centigrade temperatures,

$$\Delta t_H \cdot H = \frac{t_1 - t}{T_1}$$

and

$$1 + \frac{\Delta t_H \cdot H}{2} = \frac{2T_1 - t_1 + t}{2T_1} = \frac{2 \cdot 273 + t_1 + t}{2T_1} = \frac{273}{T_1} + \frac{t_1 + t}{2T_1}.$$

Now, in place of formula (89), we obtain

$$H = \frac{273 p_1}{T_1 \gamma_1 g \log e} \left[1 + \frac{2(t_1 + t)}{4 \cdot 273} \right] \log \left(\frac{p_1}{p} \right).$$

Here $\log e = 0.4343$, and the reciprocal of the modulus is 2.3026.

The preceding formula is more elegant than this one, but we derived it in order to afford a better comparison with the Laplace formula.

Note that $\frac{p_1}{\gamma_1} \cdot \frac{273}{T_1} = \frac{p_0}{\gamma_0}$, i.e., it is equal to the ratio of

the air pressure at zero temperature to the air density at the same temperature; we see then that this is a constant for any gas.

Consequently, putting $g = 1$ (for 45° latitude), we find the height in meters:

$$H = 18405 \left(1 + \frac{2(t_1+t)}{1092} \right) \log \left(\frac{p_1}{p} \right).$$

This formula differs from the Laplace formula solely in the coefficient accompanying $(t_1 + t)$, which according to Laplace is

equal to 1000. The error in the height according to the formula of the renowned astronomer could be significant when the temperatures $(t_1 + t)$ amount to large sums, but this will not be normally encountered. We repeat that with this correction Laplace's formula could be assumed ideally exact [cf. (87) and (88)].

We have to use formula (89) or (90), or better yet formula (87), which has absolute exactness for a gaseous atmosphere, provided the temperature decrease is strictly proportional to the elevation [instead of (87), we could have also used formula (94)].

91. We should not forget that our aim is to determine the expansion of the aerostat volume as the aerostat gains altitude.

Formula (86) may serve this purpose. For in this formula, according to (89) and (82), $\frac{\eta \gamma_1 g}{(\text{const} + 1) p_1} \cdot H = \frac{\Delta t}{T_1}$, so that we

can eliminate η from the exponent in formula (87); we then find

$$92. \quad \frac{U}{U} = \frac{\gamma}{\gamma_1} = \left(1 - \frac{\Delta t}{T_1}\right)^{\frac{T_1 \gamma_1 g}{\Delta t \cdot p_1} H - 1};$$

where Δt is the temperature difference between the two points, expressed in centigrade degrees.

93. Likewise, instead of formula (85), we obtain

$$\frac{p}{p_1} = \left(1 - \frac{\Delta t}{T_1}\right)^{\frac{T_1 \gamma_1 g}{\Delta t \cdot p_1} \cdot H},$$

whence

$$94. \quad H = \frac{\Delta t \cdot p_1}{T_1 \cdot \gamma_1 g} \cdot \frac{\log \alpha \left(\frac{p_1}{p}\right)}{\log \alpha \left(\frac{T_1}{T_1 - \Delta t}\right)}.$$

95. According to formula (92) or (86), we may compile a table of the ratios of filling of the aerostat with gas for an ascent from sea level to some height.

We assume $\eta = 1/2$ as a start, i.e., a temperature decrease of 5°C for every kilometer of ascent; $\gamma_1 = 0.001293$; $g = 1$ [for latitude 45° , cf. formula (71)]; $p_1 = 103.33$ kg per square decimeter;

const = 2.441; $T_1 = 273^\circ$, i.e., 0°C .

We find the temperature from formula (78) and convert it to centigrade degrees (cf. Table 1).

We present also Table 2 for the variation in air density up to an altitude of 100 km.

97. Clearly, from Table 1, an ascent to a height of 6 km, for instance, would mean that the aerostat could be filled while below, at sea level, with gas to only $1/2$ its total volume. The temperature decrease is proportional to the increase in height only for moderate heights; further up it will increase not quite so rapidly, so that the height of the atmosphere will be far greater than indicated by our formula. In general, the formula can be applicable to the extent to which the law of temperature decrease which we adopted remains applicable. Up to 10-20 km, the formula will yield results reasonably close to reality.

98. If we assume no change in temperature, then equation (89), for instance, will lead to

$$\frac{p}{p_1} = \frac{U_1}{U} = e^{\frac{-\gamma_1 g}{P_1} \cdot H},$$

where e is the base of the Napierian logarithms. Assuming the same conditions as before, but a constant temperature of 0°C , we now proceed to calculate the degree to which the aerostat will be filled (cf. last column in Table 1). On comparing the last two columns, we see that less hydrogen will have to be taken on when the temperature is constant, but the difference is slight even at a high altitude; for example, at an ascent to 10 km, in the presence of a progressive decrease in temperature, about 0.300 of the balloon's volume will be filled as compared with 0.283, or just about the same fraction of the volume, when the temperature does not change. We may note, further, that this difference will increase gradually, will attain a peak at an altitude of 6 km, and will then decline and

TABLE 1

Height, km	Temperature, °C	Balloon fillion ratio, U_1/U	U_1/U , but at constant tempera- ture of °C
0	0	1.0000	1.0000
1	- 5	0.8960	0.8815
2	- 10	0.8000	0.7770
3	- 15	0.7145	0.6847
4	- 20	0.6359	0.6037
5	- 25	0.5636	0.5321
6	- 30	0.5002	0.4690
7	- 35	0.4419	0.4134
8	- 40	0.3894	0.3644
9	- 45	0.3422	0.3212
10	- 50	0.2998	0.2832
11	- 55	0.2619	0.2496

TABLE 2

Height, km	Troposphere		Stratosphere temperature 75°C	
	Temperature, °C	Balloon filling ratio, U/U ₁	Height, km	Reciprocal filling ratio U/U ₁
0	0	1.0000	16	7.25
1	- 5	0.9013	17	8.62
2	- 10	0.8120	18	10.21
3	- 15	0.7276	19	12.14
4	- 20	0.6519	20	14.41
5	- 25	0.5823	25	35.7
6	- 30	0.5192	30	80.6
7	- 35	0.4619	35	190.5
8	- 40	0.4101	40	450.4
9	- 45	0.3628	46	1 264
10	- 50	0.3203	50	2 519

[Table 2 continued next page]

[Table 2 continued]

Height, km	Troposphere		Stratosphere temperature 75°C	
	Temperature, °C	Balloon filling ratio, U/U ₁	Height, km	Reciprocal filling Ratio U/U ₁
11	- 55	0.2821	56	7 040
12	- 60	0.2476	60	13 720
13	- 65	0.2166	65	37 880
14	- 70	0.1890	70	78 740
15	- 75	0.1641	75	185 900
			80	439 000
			85	1 040 000
			90	2 487 000
			95	5 814 000
			100	13 720 000

vanish at a fairly significant height, so that the filling ratio U/U_1 at that height will be the same, regardless of whether the temperature in the atmosphere decreases or not.

99. For low ascents, formulas (86), (87), or (92) may be simplified -- the results will come out the same.

Thus, from equation (86) we have

$$H = \frac{1}{\Delta t_H} \left[1 - \left(\frac{\gamma}{\gamma_1} \right)^{\frac{\eta}{\text{const}+1-\eta}} \right].$$

If we expand the power function in this equation into a series, we obtain

$$H = \frac{1}{\Delta t_H} \left\{ \frac{\eta}{\text{const}+1-\eta} \cdot \ln \left(\frac{\gamma_1}{\gamma} \right) + \frac{1}{1 \cdot 2} \left[\frac{\eta}{\text{const}+1-\eta} \cdot \ln \left(\frac{\gamma_1}{\gamma} \right) \right]^2 + \right. \\ \left. + \frac{1}{1 \cdot 2 \cdot 3} \left[\frac{\eta}{\text{const}+1-\eta} \cdot \ln \left(\frac{\gamma_1}{\gamma} \right) \right]^3 + \dots \right\}.$$

This is a rapidly converging series. Restricting ourselves, therefore, to the first term in brackets, we obtain

$$100. \quad H = \frac{\eta \ln \left(\frac{\gamma_1}{\gamma} \right)}{(\text{const} + 1 - \eta) \frac{\Delta t}{H}} .$$

The simplification may be carried even further if we also expand $\ln \left(\frac{\gamma_1}{\gamma} \right)$ into a series. When this is done, we find

$$101. \quad \ln \left(\frac{\gamma_1}{\gamma} \right) = 2 \left[\frac{\frac{\gamma_1}{\gamma} - 1}{\frac{\gamma_1}{\gamma} + 1} + \frac{1}{3} \left(\frac{\frac{\gamma_1}{\gamma} - 1}{\frac{\gamma_1}{\gamma} + 1} \right)^3 + \dots \right] .$$

Noting that this is also a rapidly converging series, and again, dropping all but the first term, in the denominator of which $\frac{\gamma_1}{\gamma} \approx 1$, we find

$$102. \quad \ln \left(\frac{\gamma_1}{\gamma} \right) = \frac{\gamma_1}{\gamma} - 1 .$$

Accordingly

103.

$$H = \frac{2\eta \left(\frac{\gamma_1}{\gamma} - 1 \right)}{(\text{const} + 1 - \eta) \frac{\Delta t}{H}} \cdot$$

whence

$$\frac{\gamma_1}{\gamma} = \frac{U}{U_1} = 1 + \frac{\text{const} + 1 - \eta}{\eta} \cdot \frac{\Delta t}{H} \cdot H \cdot$$

On the basis of (82), on the other hand, eliminating $\frac{\Delta t}{H}$, we obtain

104.

$$\frac{U}{U_1} = 1 - \frac{(\text{const} + 1 - \eta) \gamma_1 g}{(\text{const} + 1) p_1} \cdot H \cdot$$

105. Assuming here, for sea level and normal conditions:
 $\gamma_1 = 0.001293 \text{ kg/dm}^3$, $c_v = 0.169 \text{ cal}$, $g = 100 \text{ dm/sec}^2$, $M_e = \frac{1}{4240}$
 $\text{cal/kg}\cdot\text{dm}$, $T_1 = 273^\circ$ (or 0°C), $p_1 = 103.33 \text{ kg}$, and $\eta = 1/2$, we

find const = 2.441 and

$$106. \quad \frac{U}{U_1} = 1 - 0.10748H,$$

where H should be expressed in kilometers.

Thus, when H = 1 km, the filling ratio $\frac{U}{U_1}$ will be 0.902, and will be 0.896 according to the exact Table 1; the error is about 1/150 of the quantity to be determined. It is clear that this last formula could not be applied for ascents exceeding 1 km, but it could be adapted to plateaus of any elevation except that the constant factor will be different.

107. Formula (100) is more exact, and from it we obtain

$$\ln \left(\frac{\gamma_1}{\gamma} \right) = \ln \left(\frac{U}{U_1} \right) = \frac{(\text{const} + 1 - \eta) \Delta t}{\eta} \cdot H,$$

or, on the basis of (82) and conditions (105):

$$\ln \left(\frac{U}{U_1} \right) = \frac{(\text{const} + 1 - \eta) \dot{\gamma}_1 g}{(\text{const} + 1) p_1} \cdot H = 0.1075H;$$

$$\lg \left(\frac{U}{U_1} \right) = 0.046684H.$$

Here the common Briggs logarithm is expressed as a function of the height in km.

108. If, for example, $H = 1$ km, we find $\frac{U_1}{U} = 0.898$, and the error (Table 1) will now be far less, to be specific about $1/500$ of the quantity in question. Moreover, this last formula may be applied over a far wider range. Thus, putting $H = 10$ km, we find $\frac{U_1}{U} = 0.3413$, whereas from Table 1 we find about 0.3. Therefore, the error is not very great in this case, too.

109. Apropos, according to the Babinet formula we may provide a simplified formula for the height as a function of the ratio p_1/p

of the barometric heights or pressures at two extreme points. For this purpose we take formula (89). In this formula, we find, by expanding the logarithm in a series:

$$\ln \left(\frac{p_1}{p} \right) = 2 \left[\frac{\frac{p_1}{p} - 1}{\frac{p_1}{p} + 1} + \frac{1}{3} \left(\frac{\frac{p_1}{p} - 1}{\frac{p_1}{p} + 1} \right)^3 + \dots \right].$$

Discarding all but the term with p_1/p close to unity, we obtain

$$\ln \left(\frac{p_1}{p} \right) = 2 \left(\frac{p_1 - p}{p_1 + p} \right).$$

Consequently,

$$H = \frac{2p_1}{\gamma_1 g} \left(\frac{p_1 - p}{p_1 + p} \right) \left(1 + \frac{\Delta t}{2T_1} \right).$$

Here Δt is the temperature difference between two points, which is usually positive.

110. Let us bear in mind (in calculating the coefficients), that $\frac{p_1}{\gamma_1} = \frac{p_0}{\gamma_0} \cdot \frac{T_1}{273}$, i.e., $\frac{p_1}{\gamma_1}$ equals the ratio of the pressure p_0 at zero temperature to the density at that temperature multiplied $\frac{T_1}{273}$, for which see formula (90).

III. OF WHAT MATERIAL SHOULD THE AEROSTAT BE MADE?

111. The formulas and theorems derived here are valid only if the mass and the composition of the gas filling the aerostat remain unchanged, i.e., if the envelope completely isolates the light gas from the atmosphere. And this would hardly be possible if an envelope made of material of plant or animal origin were utilized, since all these materials are permeable to gases, even when there are no visible holes in them. This depends not on the difference between the pressures inside and outside the aerostat, but on the independent, very rapid, and never ceasing motion of the gas molecules, which in one way or another will penetrate any envelope of organic origin.

Thus, the aerostat will not only lose some of the light gas with which it is filled, but will also acquire a proportionate amount of the heavier air, forming a mixture of gases, including the light gas itself. The volume acquired will be 3 to 4 times less than the volume lost (depending on the nature of the gases inside the aerostat) in accordance with known diffusion laws.

Thus, two phenomena are going on at the same time: a decrease in the volume of the interior gas and an increase in its mean density. As a result, the buoyancy of the aerostat will decrease, and the opposing force, i.e., its weight, will increase, so that the aerostat either descends or tends to descend.

If only it were easy to expel the air drawn into the envelope and replace it with light gas! But in practice this is impossible without releasing all the gas in the envelope.

An organic envelope is inflammable, and this constitutes a serious inconvenience, since it eliminates any possibility of utilizing fire and fire-operated engines on board the aerostat. In fact, a single spark or jet of incandescent gas or air might set fire to the hydrogen and the tenuous envelope of the aerostat and cause a catastrophic crash and the death of the crew.

It would be preferable to use a metallic material in building the aerostat. Moreover, such a material would be impermeable and fire-proof, as well as endowed with a number of other advantages such as: strength, durability, cheapness, and nonhygroscopicity. By making it safe to use fire on board, it would also make it possible to vary the temperature of the gas over a certain range, by means of the combustion products, and thereby facilitate vertical control of the aerostat without loss of gas and ballast.

112. But despite its advantages, this material also has certain shortcomings. First of all, metal is heavy and the question arises: could an aerostat raise a massive metal shell aloft?

Would it not be found necessary to use iron, or some other metal, so thin that it would defy successful fabrication or rapidly tear, crumple, curl up, or rust away. Finally, might not the stiffness of the metal constitute an insurmountable obstacle to the use of this type of material?

Actually, the first attempts to design a spherical metal aerostat ended in complete failure*. But then Schwarz built an elongated metal dirigible and successfully flew it. Thus, the view of the VII Aeronautical Section of the Imperial Russian Technical Society, which had examined my own plans for a metal dirigible in 1890, long before Schwarz's experiment, was confirmed; the Society expressed the opinion that aerostats would probably be made of metal as time went by.

113. I shall calculate the radii of spherical aerostats made of metal sheet of different thickness and designed to lift only the envelope and the gas.

We have

$$\frac{4}{3} \pi R^3 (\gamma_a - \gamma_g) = 4\pi R^2 q_{env},$$

where π is the ratio of the circumference to the diameter; R is the radius of the sphere; q_{env} is the weight of a unit area of the envelope, and $\gamma_{air} - \gamma_{gas}$ is the difference in the densities of the air and the gas. From the equation, we find

$$R = \frac{3q_{env}}{\gamma_{air} - \gamma_{gas}}.$$

*In 1831, Dupont-Delcour and [Marey] Monge designed a spherical aerostat made of copper. Their experiment was not successful.

Clearly then, the envelope may be arbitrarily massive or thick, provided the radius or size of the sphere is proportionately large.

114. If we assume that the aerostat is filled with hydrogen, we may calculate as follows, using formula (113).

Consider an aerostat made of aluminum 0.08 mm thick; one square meter of this envelope weighs about 0.2 kg. The diameter of the sphere will be one meter. Do not imagine that this material is very frail: I have a calling card in my possession which is just as thin, yet to the touch it feels just as tough as an ordinary calling card made of thin cardboard. We could use copper foil to achieve the same results, but it would be much softer. Sheet brass 0.07 mm thick, i.e., almost the same thickness as the aluminum, would require a diameter of 2.8 meters. Iron of the same thickness is much stronger and slightly lighter. Iron or copper material twice as thick, one square meter of which weighs about 1 kg (1.14 kg to be precise), would require a diameter of 5.7 meters. Sheet tin, like that used for the lids of shoe-polish cans, etc., is a good example of material of this type. If we used material twice this weight, for example, the tin used to make cheap tin lampshades, molds for ice cream, etc., then the diameter of the sphere would have to be twice as large again, i.e., about 11.4 meters.

115. It would be most difficult to make a spherical metal aerostat, so I do not suggest that this shape be used for the actual construction: my purpose is solely to indicate the size of the sphere in relation to the weight of the envelope and the degree of feasibility.

Aerostats made of the same materials but with twice the linear dimensions would be capable of lifting not only their own weight but also a useful load equal to the weight of the envelope.

116. The problem of coping with meteorological influences makes heating the gas essential. Only by controlling the temperature of the gas can we hope to achieve vertical control without loss of gas and ballast. No other means could possibly counteract the powerful heating effect of the sun's rays* (on this point cf.

*Incidentally, I might point out that Meudebec agrees completely that heating is the best way to obtain vertical maneuverability, provided there is no danger of a conflagration consuming flammable envelopes.

K. Tsiolkovskiy, "Prostoye ucheniye o vozdushnom korable" [A simple treatise on the airship]). And once fire is employed, envelopes which are nonflammable or at least not susceptible to fire hazards will be required.

117. As for the problem of coping with the stiffness of metallic materials, there will be time enough to deal with this highly involved question later.

IV. CERTAIN CONDITIONS WHICH MUST BE SATISFIED
BY ANY DIRIGIBLE

118. The use of metallic material is not a prerequisite for the maneuverability, but it is a prerequisite for the practicality, safety, cheapness, popularity, and development of airships. Moreover, this material may be considered indispensable to vertical maneuverability and vertical control. The other conditions which an aerostat must satisfy are the following.

a)* It must be slender and taper horizontally at both ends, so as to offer minimum resistance to the wind when moored to the mast or moving freely through the air. In this respect, the aerostat must resemble a fish, bird, or cruiser.

b) Not only the envelope but all parts of the aerostat must come as close as possible to satisfying this condition.

c) It must be possible to vary the volume of the aerostat, or the volume of the gas envelope, without impairing the smoothness of its shape and without causing wrinkles which might lead to increased drag or cracks. Variation of the volume is necessary to enable the light gas to expand and contract freely in response to the temperature and pressure changes encountered during an ascent to great heights.

d) The aerostat must be sufficiently strong, i.e., it must offer sufficient resistance to the pressure exerted by the gas, to its own weight, to wind loads, and so forth. This is achieved by giving a certain thickness to the parts of the aerostat and by making them of the best available materials.

e) The aerostat must be in stable equilibrium in the horizontal position; in other words, it must have a stable direction of the longitudinal axis. The horizontality of this axis must not be disturbed by changes in engine load, even when the engines are stopped or started. Its stability must also remain unimpaired when people move around in the gondola, and in the presence of irregular, i.e., nonhorizontal, nonlinear, or nonuniform motions of the air surrounding the aerostat.

f) The aerostat must be capable of ascending and descending without losing gas or ballast.

g) The aerostat must be capable of varying its lift or buoyancy, to accommodate changes in the weight of the cargo or passengers, and in order to cope successfully with meteorological influences, principally the variable force due to sunlight acting on the envelope.

h) Exhaustion of the combustible fuel responsible for the independent motion of the aerostat must not result in loss of altitude.

i) The independent horizontal velocity of the aerostat must not be small or insignificant compared with the wind velocity. Briefly, the velocity must not be less than the velocity of a strong gust of wind.

In specifying these requirements, we simultaneously describe the gas airship that meets them, as I shall prove later by calculation. In due course, I shall examine the methods of building an aerostat and controlling it in flight, and several other questions.

V. BRIEF DESCRIPTION OF A METAL AIRSHIP*

119. Figure 1 (right) shows the parts of the aerostat projected onto a vertical plane passing through its longitudinal axis, in other words, a longitudinal section.

Fig. 1 (left) is a transverse section along the line A-B, or the projection on a transverse vertical plane.

In general appearance our metal airship resembles an ordinary dirigible. The shape of the envelope, the propeller, the rudder, the gondola, and the motor are all more or less the same.

120. It is even easier to demonstrate the possibility of designing an elongated metal bag capable of changing shape and even of folding flat without suffering damage and without losing its generally smooth shape than I thought when I made my earlier contributions on this subject (Aerostat metallicheskii, upravlyaemyi [The Metal Dirigible], and Prostoye ucheniye o vozdushnom korable [A Simple Treatise on the Airship]).

121. Join two rectangular strips of cardboard so that a shape identical with the longitudinal section of the aerostat (Fig. 1) is formed. Then glue thick paper across one or both faces of this elongated cylinder; you will end up with something in the nature of an elongated drum or sieve (Fig. 2).

This constitutes a model of the aerostat, though one of fixed volume.

122. But with a sharp knife we can cut the flat sides of this bag into parallel strips perpendicular to its longitudinal axis (Fig. 2).

Now, by squeezing the curved walls of the cylinder, forcing them closer together and allowing them to spring apart, we can show

*This description is intended to give the reader some idea of what a metal aerostat is, so that he will be in a position to understand what follows; however, the description lays no claim to completeness, nor is it by any means the last word. On the contrary, as we shall see below, important modifications of the airship design described are both possible and useful. I shall devote a special chapter to an analysis of these modifications.

that the volume and shape of the bag can be made to vary quite drastically without any folds being formed. But the rub is that gaps will form between the vertical strips; these gaps will be the narrower the more elongated the bag and the thinner the strips themselves (Fig. 3).

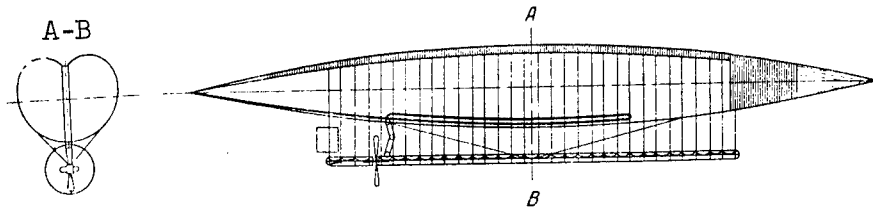

Fig. 1

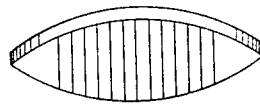

Fig. 2

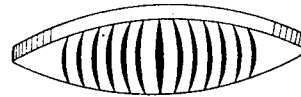

Fig. 3



Fig. 4



Fig. 5

123. It will be of some help if the strips are made in advance out of corrugated material, such as corrugated paper, the corrugations in which should run the length of the strips; Fig. 4 illustrates one such strip.

On making a bag out of strips like these, but this time pre-joined to form a single whole (Fig. 5), we obtain a leakproof paper or metal tank (gas holder), sealed on all sides and capable of a wide variation in shape and volume under certain conditions, determinable by mathematical analysis in conjunction with data on the properties of the materials, and even of folding flat without bursting or crumpling (of course, only the side walls fold flat).

124. The metal envelope of our airship can be constructed in the same or a similar manner. This envelope will be made of corru-

gated metal sheet with the corrugations following the circumference of transverse sections through the aerostat (Fig. 1).

125*. But besides this thin corrugated sheet, the envelope will also have certain more massive parts: there will be two pairs of longitudinal girders, running the length of the envelope at top and bottom, and a number of circular transverse ribs, resembling barrel hoops, serving to connect these girders together (Fig. 1). Fig. 5 will also help the reader to understand the arrangement of the envelope and its stiffening members. The ends of the envelope, even though they are still more solidly reinforced, form smooth conical surfaces.

126*. Fig. 1 shows how the gondola is held in place, that is, the suspension of the passenger cabins, cargo and machinery compartments, etc. It hangs from two systems of vertical chains, which are anchored to the two upper longitudinal girders. These chains pass freely through the bottom girders. Thus, the top of the envelope is pressed inward along its entire length, so that the gas inside the aerostat is constantly under a slight pressure. When it expands, the envelope swells, the gondola is raised, and part of each chain runs through a gastight seal located inside the aerostat; when it contracts, the envelope closes up, its volume diminishes, and a part of each chain is pulled outside.

127. When the chains are connected thus, the aerostat is, as it were, always full (rounded out), and its longitudinal axis will be fairly stable. But this requires that the chains be connected in some way to the pair of lower girders. Only then will the equilibrium or rather the horizontality of the longitudinal axis be stable in response to random tilting of the aerostat. When the gas expands, for example when the aerostat rises, or when the gas is compressed, for example when it descends, the chains must be disengaged from the lower girders in order that the envelope may assume its normal shape (Fig. 1).

128. The chains in the middle section of the aerostat are never coupled to the bottom girders, and this is a very important point, since it allows the gas to expand and contract slightly without the necessity of releasing the other chains.

129. Fig. 6 shows how the upper longitudinal girders are connected to the hoops and the envelope; the connection is hinged and almost frictionless, so that the envelope is free to rotate about the girder. A similar connection is used at the bottom. But this joint is not gastight; gas will leak through it. It is there-

fore covered by a strip of thick, soft, impermeable material running the length of the envelope. There will be four such strips, corresponding to the number of longitudinal girders. Fig. 7 depicts this seal in transverse section.

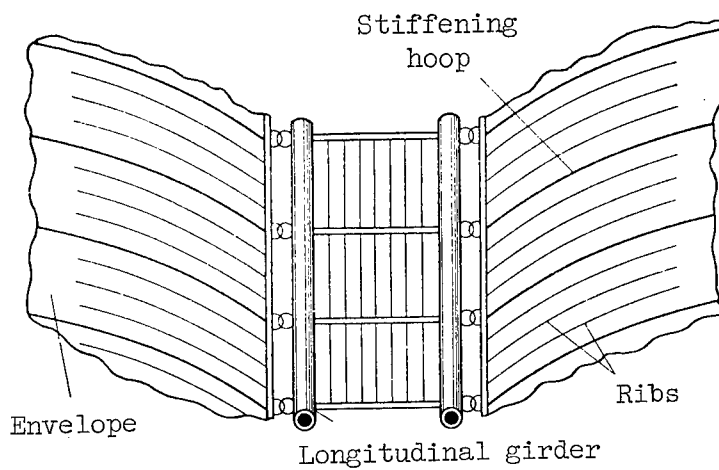

Fig. 6

130. The design of the gondola will be clear from Figs. 1 and 8.

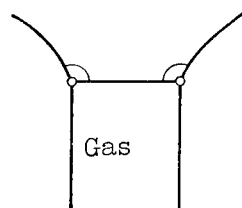

Fig. 7

131. The tops of the chains, remaining inside the envelope, may consist of one or several links; likewise the exterior part of the chains which never goes inside the envelope. But the middle section of the chains, which slides through the bottom girders, is made up of numerous links. The design of this part of the chains is clear from Fig. 9. Such a chain is capable of bending in all directions, like a rope. A short link made of very strong material is inserted between pairs of longer links. These short links also have a recess into which fit special pins used to connect the links and the envelope, except in the middle of the envelope where the chains are always free. It is clear from this description that the chains will never break as the gondola rocks and heaves. The free-sliding chains may be replaced by wire ropes or by ordinary chains with special provision for sealing off the gas.

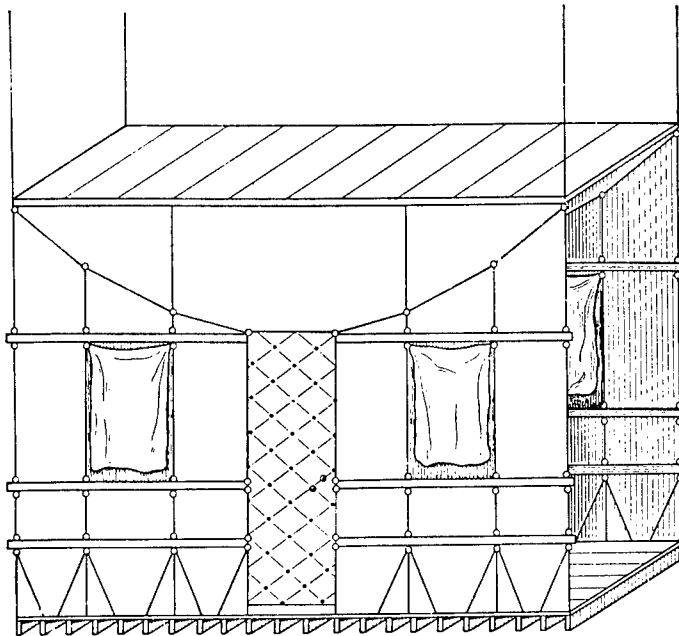

Fig. 8

132. The black tube inside the envelope (Fig. 1) is intended for heating the light gas and varying the lift force acting on the aerostat over a wide range. Increasing the temperature of the gas and of the envelope not only has the effect of augmenting the lift force, but is especially useful, and even imperative, in temperate and cold latitudes where snow falls. Snow will melt and run off a warm envelope, before it can add to the weight of the aerostat or spoil the envelope by turning to ice under the influence of, say, the sun's rays or a warm air current. Thick snow may accumulate on certain portions of a cold envelope, however, and the horizontality of the longitudinal axis may be affected; removing the snow by mechanical means is no easy job.

133. The black tube is heated by combustion products from the airship engines. These products are allowed to escape into a special temperature regulator (Fig. 1, Fig. 10). There they encounter two openings partially covered by a slide valve, which is adjustable manually (or automatically), so that one portion of the hot gases is expelled through an exhaust pipe and carried off by the slip stream, thereby averting any exposure of the passengers in the forward part of the gondola to the fumes, while the other portion of the gas is deflected through a special vertical branch into the black tube inside the envelope, which it leaves in the rear part of the envelope, without having polluted it.

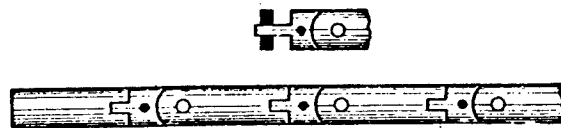

Fig. 9

The distance between the envelope and the gondola varies, so the exterior exhaust pipe must be somehow adapted to meet the situation.

134. Usually, both branches will be half-open and the light gas will be heated to a certain temperature. But as the slide valve

is displaced, the temperature of the gas will either rise or fall. This provides a means of controlling the lift force acting on the aerostat, and consequently a means of controlling its vertical motion.

135*. When the aerostat is not in translational motion, the horizontality of the longitudinal axis is insured by means of a very slight displacement of the gondola relative to the envelope. This displacement is effected by means of the diagonal ties visible in Fig. 1; the displacement is accompanied by a deflection of the chains through a very small angle (not greater than 5° to 10°).

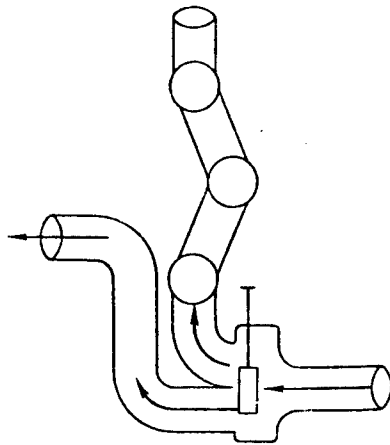

Fig. 10

When the aerostat is in rapid horizontal motion, on the other hand, there is another, though less direct method available -- this involves the adjustment of the horizontal control surfaces which act somewhat in the manner of a bird's tail. These surfaces, which can be rotated at will, are driven automatically by a small motor*.

136. Instruments indicating the pressure difference between inside and outside the aerostat (manometers) must be placed in the central lower section of the envelope. When the pressure is abnormally high, the manometer will set off an alarm signal. The same

thing happens when the pressure is exceptionally low, and thereby threatens to disturb the horizontality of the longitudinal axis; only then the alarm will ring at a different pitch. Finally, if ever the pressure threatens the integrity of the envelope, a safety valve in the stern end of the envelope will open automatically to release the gas and prevent an accident.

137. A catwalk, not shown on the drawings, which serves to provide access to the most important parts of the envelope, runs around the envelope, along the four girders. Fig. 1 shows, to a scale* of 1:500, a metal airship for 200 passengers, as long as a large ocean-going steamship.

*In the present [Russian] edition, the scale of Fig. 1 is about 1:2300.

VI. THE SHAPE OF A DIRIGIBLE

Shape of the envelope

138*. The chains supporting the gondola are not usually connected to the top of the envelope, as in our case (Fig. 1).

I have been able to think of no improvement on this system. Suppose, for instance, that the chains were attached to the sides of the aerostat, as in almost all soft-envelope designs. In the first place, the chains would be extremely long and consequently produce additional resistance to the motion of the airship. In the second place, a well inflated aerostat would be in no position to increase its volume further, and might burst or lose a portion of its gas if an attempt were made to do so. If it were not full, then the horizontality of the longitudinal axis of the envelope would not be stable: the aerostat would pitch or "peck," now at the bow, now at the stern. In order to eliminate this "pecking," we would have to have a ballonnet, containing a variable amount of air, inside the envelope. This ballonnet would have to be huge in order to satisfy the practical requirements relating to the expansion of the gas; but it would have a host of disadvantages, which it would take much too long to go into here, and would be simply infeasible in relation to a metal aerostat, since it would cancel out the advantages of using metal for the envelope. Actually, the ballonnet could be made only of organic material, which is affected by diffusion. Consequently, after a certain time the hydrogen would mix with the air filling the ballonnet, and eventually we would be harboring in the interior of the aerostat a "fused, loaded bomb" capable of going off at any second and scattering the metal envelope "to the four winds" in the ensuing explosion, i.e., we would make it possible for air to get into the aerostat. And then what would be the use of a metal envelope in the first place?

139. For the same reason (difficulty in varying the volume), we cannot suspend the chains from the bottom of the envelope or the bottom girders. There are still other reasons against attaching the gondola in any other way than the one contemplated.

As for the rocking of the gondola as a result of this method of suspension, this problem may be eliminated by the use of diagonal

transverse and longitudinal (Fig. 1) braces (of variable length).

140. Suppose that the envelope is soft and shaped more or less like a fish. We blow a certain amount of light gas into this envelope and allow it to rise into the air. The shape of the gas or the envelope will depend on many factors, for example:

a) on the extent to which the envelope is filled with gas, or the gas pressure;

b) on the geometrical properties of the soft surface itself; thus, a highly inflated envelope may assume the shape of the most varied solids of revolution; even irregular shapes of infinite variety are possible;

c) on the mass distribution of the envelope over its surface, i.e., the envelope cannot be of constant thickness, and this fact will have an effect on the envelope shape, particularly when the envelope is not highly inflated;

d) on the total weight of the envelope in relation to the lift force;

e) on the relative load;

f) on the distribution of the load and the manner in which it is secured.

Thus, depending on the distribution of the load, a soft envelope may assume one of three principal shapes shown in Fig. 11.

141. Let us narrow down the problem and return to a metal aerostat conforming to a certain design.

In the folded form, it has the shape of an elongated cylindrical box (Fig. 2, Fig. 5) with flat and likewise elongated sides.

These sides form two equal planes that almost coincide, so that the height of the cylinder, or the distance between these planes, will be comparatively small. When the aerostat is inflated with gas, it assumes a certain shape, (Fig. 1). The middle section of the aerostat remains essentially cylindrical, but the sides become more or less rounded.

142. The actual shape of the envelope will be clear from the longitudinal section (Fig. 1) and the transverse sections (Figures 1, 13, 14, 15, 16).

The longitudinal section varies, but it obviously depends on us, i.e., on the geometrical properties of the flat sides of the cylinder (Fig. 2, Fig. 5). The smooth curve bounding the section may be expressed by some equation chosen as our needs dictate, i.e., in designing the aerostat.

We cannot give the transverse section of the envelope any shape we please, however, though theoretically the shape depends on the distribution of the mass of the envelope among its several parts, on the manner in which the gondola is suspended, and on the longitudinal tension of the corrugated surface of the aerostat.

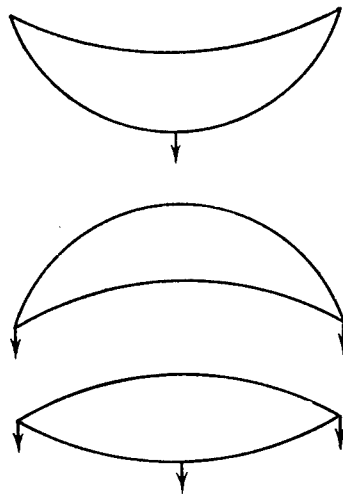

Fig. 11.

Shape of Transverse Section of a Cylindrical Aerostat¹

I have used, in general, two methods to predict and clarify

¹The equations in this chapter are applicable to a soft envelope no less than to a metal envelope, and accordingly are of more than narrow interest.

aeronautical phenomena.

143. The first of these is a purely analytic approach; but this has proved to be either very complicated or almost totally unsuitable for determining the shape of an airship, so that I have solved only certain special cases.

1. The Hydrostatic Model

144*. The second approach is an empirical one, involving the use of simple analysis. For example, if we make a small bag the same shape as the aerostat, from some soft, impermeable and inelastic material, and immerse this bag in water, then the bag, placed in a situation similar to that of an aerostat and full of air, will, when loaded, assume the same form and, in general, will have all the properties typical of an aerostat containing a light gas and immersed in air.

145. Consequently, using a clean water tank bounded by flat glass walls, we shall be in a position to visualize (and indeed the shape of the aerostat, and to solve certain problems relating to the stable horizontal direction of its longitudinal axis.

146. For those desirous of performing such experiments, I have the following words of advice: use an ox bladder or a large, even though very irregular, rubber bag with the openings stoppered; but whichever you use, enclose it in a well-cut and carefully sewn canvas or calico bag of the chosen shape. The impermeable rubber bag is fitted inside this bag, within its more or less irregular folds. It is also convenient somehow to attach a load to the calico bag. A sheathing of lead plates, sewn to the calico but not interconnected, could also be attached to the bag in order to increase its relative weight without affecting the flexibility of the parts.

2. Thread Model*

147*. This immersion technique is particularly valuable in solving the problem of the stable direction of the longitudinal horizontal axis of the dirigible; it is not quite so convenient for determining the shape of the transverse section, and therefore I have tried another, likewise empirical, approach. I took a thread 88 cm long and attached 12 equal loads ($q_1, q_2, q_3, \dots, q_{12}$) at equal intervals along it (Fig. 12). This thread, with or without the loads, represents the ponderable or imponderable envelope of the aerostat, or rather part of that envelope, a strip bounded by two planes normal to the longitudinal axis.

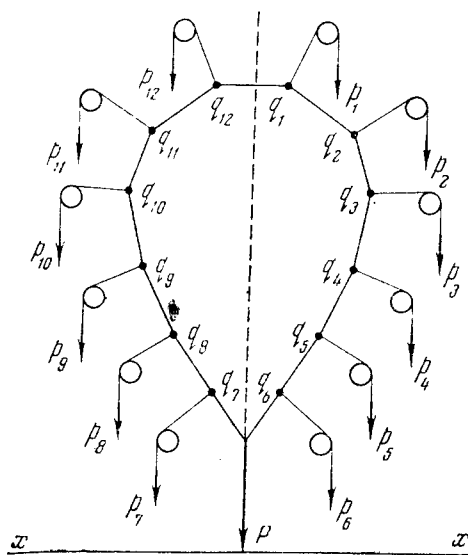

Fig. 12.

I tied the ends of the thread and laid it in a circle on a horizontal wood board. I then attached thin threads to each of the 12 loads ($q_1, q_2, q_3, \dots, q_{12}$) and suspended little paper bags ($p_1, p_2, p_3, \dots, p_{12}$) filled with different amounts of sand from the free ends of the threads, in such a way that the weight of the sand, together with the weight of the bag, was proportional to the distance y between the point of attachment ($q_1, q_2, q_3, \dots, q_{12}$) of the thin thread and the x-axis.

The pull of the paper bags represents the gas pressure inside the aerostat, which will always be normal to an element of its surface; consequently, the threads attached to the bags were wound around light grooved wheels ($k_1, k_2, k_3, \dots, k_{12}$) with a hole in the center to permit them to be pinned to the wood board. With the aid of these pulleys, by moving the pins about which they freely rotate, it is possible to arrange the threads attached to the paper in such a way that they bisect the angles of the thread polygon, i.e., so that they are always normal to a smooth curve drawn through the vertices of this polygon.

Actually, the pressure would have to be normal not to elements of the curve, but to elements of the surface of the aerostat; however, in view of the great length of the aerostat and a certain symmetry of the section, the result is almost the same.

148. The point where the threads are joined at the end of the main thread is nailed fast to the board, or we may suspend from it a load P (representing the weight of that part of the gondola corresponding to the width of the section in question) such that the point becomes fixed. We now raise the board into a vertical position, making sure however, that the x-axis remains horizontal, so that the main circular thread (envelope) is elongated upwards, and an angle, obtuse or acute, depending on the circumstances, is formed at the lowest point. The result is that 1) the threads supporting the paper bags are no longer normal to the elements of the envelope¹, and 2) the masses of the paper bags are no longer proportional to the heights y or the distances between the loads on the envelope ($q_1, q_2, q_3, \dots, q_{12}$) and the x-axis. These

¹I.e., the direction of the paper-bag threads is no longer along the bisectors of the angles.

differences must be corrected by moving the pulleys and changing the paper-bag loads. The result is a new but smaller deflection, which is corrected in the same manner, and so on. The whole procedure is actually quite simple.

I placed a sheet of white writing paper underneath the thread representing the aerostat envelope, and on it traced the transverse section. I then cut out this sheet with a pair of scissors, rounding off the angles due to the discontinuous nature of the loading and examined it carefully.

149. In the different experiments the x -axis lay at different distances from the low-point of the cross section but in the first experiments passed right through that point, i.e., the pressure difference at the low-point was assumed to be zero. The ratio of envelope weight to load (or the loaded gondola) was also varied in the different experiments.

In other experiments (F, G, H in Fig. 13), the load was suspended from a chain, the other end of which was attached not to the low-point, but to the diametrically opposite upper (not the highest) point of the envelope; the lower parts of the chain, which passed through the interior of the aerostat, was free to slide over the bottom portion of the cross section.

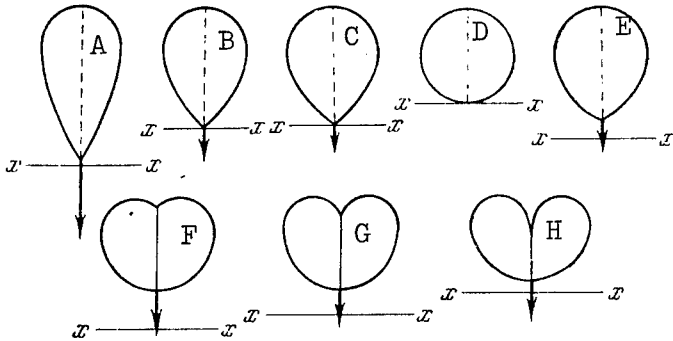

Fig. 13.

These experiments were supplemented by fairly simple calcula-

tions and reasoning. In fact, these are the chief principles I relied on in my further analysis of the shape of the transverse section of the airship. A more complete study of the aerostat and its motion will require not only greater ingenuity but also a direct investigation of an aerostat built on the basis of the first imperfect experiments and theories, and a comparison of the early inferences with the new findings.

150. When a load is attached to the low-point of the cross section and when the x-axis passes through that point, i.e., when the pressure difference at the low-point vanishes, the shape of the cross section will more and more closely approximate a circle, as the weight of the load decreases in proportion to the weight of the envelope (Fig. 12, A, B, C); thus we see that at zero load the cross section becomes a circle (D in Fig. 12); the theory is thereby confirmed; but in the case of an imponderable envelope, or when the load is infinitely large compared to the weight of the envelope, the cross section is not reduced to two parallel threads, but retains an appreciable width (A in Fig. 13).

151. When the x-axis lies below the low-point of the cross section, i.e., when the pressure difference at the low-point is greater than zero, but the method used to attach the load is the same, then the cross section will be the closer to a circle the lower the x-axis, i.e., the greater the pressure difference (E in Fig. 13). In this experiment the envelope was imponderable, i.e., the 12 loads were not attached to the main thread; the pressure at the low-point was expressed by a gas column $b = \frac{2}{3} D$ (Fig. 12).

But in the first four experiments the pressure $b = 0$; while the ratio of load to envelope weight varies progressively, thus: 1, $\frac{1}{2}$, $\frac{1}{3}$, and 0, i.e., in the first case the load was equal to the weight of the envelope, in the second case it amounted to half the envelope weight, and so on.

152. Clearly, when the relative decrease in load goes hand in hand with a constant increase in the pressure at the low-point of the cross section, the latter will approximate even more rapidly the shape of a circle.

This method, as well as the usual method of fastening the load to the sides of the envelope with strings (Krebs and Renard, Dupuy de l'Homme) has the disadvantage that the cross section contracts sharply in the horizontal direction when the cross-sectional area or the volume of the aerostat is reduced by a comparatively insignificant amount, and expands proportionately in the vertical direction, so that the area remains almost the same; the corrugations of the envelope will be heavily shortened, and the envelope itself

severely bent, and, in general, the variation in volume will be entirely out of proportion to the flexure of the envelope and the shortening of the corrugations.

I can say this after long reflection on the subject and after performing calculations which I shall not repeat here. There are a few other disadvantages: for example, if the amount of gas inside the aerostat is small, then the direction of the longitudinal axis will be highly unstable, because the pressure difference at the low-point will be much less than zero, and on the longitudinal axis tilts the aerostat will tend strongly to expand at one end and contract at the other; this will not only drastically disturb the longitudinal axis, but may produce irregular folds and the subsequent destruction of the aerostat.

153. When the chain is fastened to the diametrically opposite point, the shape of the cross section will depend on the pressure difference at the low-point, or on the relative volume of the gas inside the aerostat (F, G, H in Fig. 13).

The pressure at the low-point will vary from infinity to zero and less, and the relative volume or the cross-sectional area will vary from 1 to $1/2$. The higher the chain rises, the greater the volume and the greater the pressure; the further the chain falls, the smaller the volume and the lower the pressure. In the three experiments depicted, the envelope was assumed to be imponderable, i.e., loads were not attached to the thread, and the pressure at the low-point, ascertained by simple calculation, was found to be $b = D$, $3/4 D$, and $1/3 D$, respectively.

As we shall see, for this cross section, when the envelope is weighted, the pressure is lower.

154. This method of fastening the chains is preferable for a variety of reasons:

1) the cross section is forced inward in the vertical direction, so that the height of the aerostat is almost $1-1/2$ times less than when the chains are attached in the usual manner; this makes it easier to seek protection from opposing air currents by descending closer to the surface or sheltering behind woods;

2) the bulk of the chain is concealed inside the envelope, and only a short length projects below the bottom of the aerostat; this minimizes the drag;

3) the general shape of the cross section, particularly at the bottom, is close to a circle, and coincides quite accurately with the cycloidal curve (Fig. 14) obtained by a circle rolling

along a straight line, the curve being traced by a point rigidly connected to the circle but lying outside it; the mathematical identity is not complete, but the close similarity is strikingly obvious, even when the cross section is considered imponderable; the similarity becomes even more pronounced where the usual fabric envelope is concerned; the advantage of this shape will become clear in the discussion; for the time being I shall merely point out that the bending of the envelope and the stretching of the corrugations are very slight and correspond to the change in cross-sectional area;

4) despite an appreciable change (almost double) in this area or the volume of the aerostat, the stable direction of the longitudinal axis, as demonstrated by experiments based on the immersion method, is always retained, provided the chains are not free to slide through the bottom of the cross section when the aerostat is tilted, and provided the aerostat itself is not too elongated.

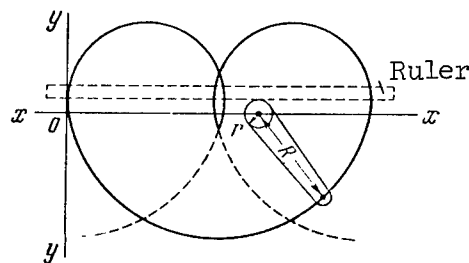

Fig. 14

155. The equation of the cycloidal curve with respect to an x -axis, coinciding (Fig. 14) with the trace of the center of a circle rolling along a straightedge, and with respect to a y -axis perpendicular to the x -axis and passing through the point where that axis intersects the curve itself, will be

$$x = r \arcsin \left(\frac{y}{R} + R - \sqrt{R^2 - y^2} \right),$$

where r is the radius of the circle, and R is the distance of the point tracing out the curve from the center of the circle

3. Analytic Determination of the Shape of the Cross Section

156. Assuming that the envelope is reasonably flexible (reasonably soft) and has a constant width and that the density of the material is constant, I shall now attempt to determine the shape of the cross section analytically.

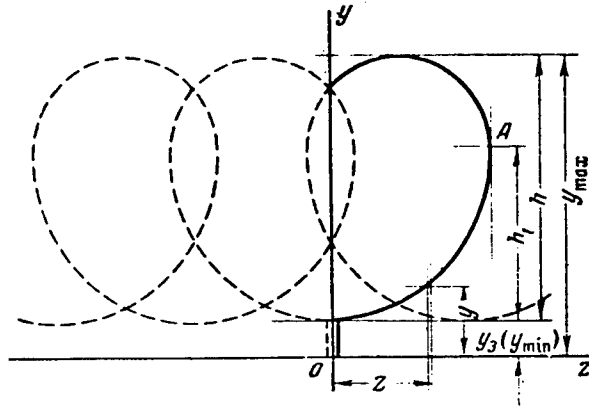

Fig. 15

157. To begin with, we are obliged to make a simplifying assumption: namely, that the length of the aerostat is very great

relative to its width or height or, more accurately, that the envelope is cylindrical in form while the shape of the normal cross section (Fig. 15) is unknown.

158. The tensile forces acting at the circumference of the envelope over unit width, will be designated t_y and t_z , the components of force in the z-direction and in the y-direction (Fig. 15).

These forces are derived from the gas pressure and the weight of the envelope. The weight of units of the length s of the envelope around the circumference of the cross section will be denoted by q .

By the gas pressure, we mean the difference between the air pressure at some point A and the pressure exerted by the gas inside the envelope at the same point.

159. Assuming that at the bottom of the envelope there is a tube (appendix)* of length y_z , full of gas and in communication with

the outside air, so that the gas pressure at the bottom of the tube is equal to the external air pressure, we find that the pressure difference of the gases at a point (z, y) is ay , where a is the difference between the densities of the air and the light gas. We may write

$$a = \gamma_{\text{air}} - \gamma_{\text{gas}}.$$

160. On the basis of the foregoing, we derive:

$$dt_y = - aydz - qds,$$

*Actually, there need be no such tube in practice. My object is solely to find a convenient means of expressing the pressure at the low-point.

$$161. \quad ds = \sqrt{1 + \left(\frac{dy}{dz}\right)^2} \cdot dz$$

and

$$162. \quad dt_z = aydy.$$

163. And since

$$\frac{t_y}{t_z} = \frac{dy}{dz},$$

then

$$t_y = \frac{dy}{dz} \cdot t_z.$$

164. On differentiating this equation, we obtain

$$dt_y = \frac{dy}{dz} \cdot dt_z + t_z \frac{d^2y}{dz^2} \cdot dz.$$

165. Eliminating dt_y , dt_z , and t_z from this equation by means of the preceding equations (160), (162), and (163), we find

$$- aydz - qds = a \cdot \frac{dy}{dz} \cdot ydy + \frac{d^2y}{dz^2} \cdot dz \cdot a \int ydy.$$

166. On evaluating the integral in this equation, and dividing by dz , we obtain

$$- ayq \cdot \frac{ds}{dz} = ay \left(\frac{dy}{dz} \right)^2 + \left(\frac{a}{2} \cdot y^2 + C_1 \right) \cdot \frac{d^2y}{dz^2},$$

where C_1 is a constant.

167. This equation can be made into a first-order equation by putting

$$\frac{dy}{dz} = y',$$

whereupon

$$ds = \sqrt{1 + y'^2} \cdot dz$$

and

$$\frac{d^2y}{dz^2} = \frac{dy'}{dz} = \frac{dy'}{dz} \cdot \frac{dy}{dy} = \frac{dy'}{dy} \cdot \frac{dy}{dz} = \frac{dy'}{dy} \cdot y'.$$

168. Using these formulas to substitute for the quantities in equation (166), we obtain

$$- ayq \sqrt{1 + y'^2} = ayy'^2 + \left(\frac{a}{2} \cdot y^2 + C_1 \right) \cdot \frac{dy'}{dy} \cdot y',$$

which is a first-order, but nonlinear equation.

169. From this we find

$$\left(\frac{a}{2} \cdot y^2 + C_1\right) y' dy' + [ay (1 + y'^2) + q \sqrt{1 + y'^2}] dy = 0.$$

170. Here the variables are not separated, but simplification is possible: putting $1 + y'^2 = u^2$, we obtain $y' dy' = u du$; hence, dividing by u , we get

$$\left(\frac{a}{2} \cdot y^2 + C_1\right) du + (ayu + q) dy = 0.$$

171*. Here the integrability condition is fulfilled, so that

$$\int \left(\frac{a}{2} y^2 + C_1\right) du + \int (ayu + q - \int ay du) dy = \left(\frac{a}{2} \cdot y^2 + C_1\right) u + qy = C_2.$$

Here C_2 is a second constant.

172. From this last equation we find

$$u = \frac{C_2 - ay}{\frac{a}{2} \cdot y^2 + C_1}.$$

173. But this is not all, since, dropping the notation of (167) and (170), we get

$$\frac{dy}{dz} = \frac{\sqrt{(C_2 - ay)^2 - \left(\frac{a}{2} y^2 + C_1\right)^2}}{\frac{a}{2} \cdot y^2 + C_1}$$

or

$$\frac{dy}{dz} = \sqrt{\left(\frac{C_2 - ay}{\frac{a}{2} \cdot y^2 + C_1}\right)^2 - 1.}$$

174. For the integration we find

$$dz = \frac{\left(\frac{a}{2} y^2 + C_1\right) \cdot dy}{\sqrt{(C_2 - ay)^2 - \left(\frac{a}{2} \cdot y^2 + C_1\right)^2}}.$$

For each y formula (173) yields two derivatives; these are equal but have different signs. Clearly then, the curve is symmetrical about some axis parallel to the ordinate axis.

175. Assuming $\frac{dy}{dz} = 0$ in equation (173) and applying this equation to the aerostat in question (Fig. 1), we find that $y_{\min} = y_3$ and $y_{\max} = y_3 + h$, where y_3 is the height of the appendix and h is the height of the envelope.

176. This enables us to find the constants C_1 and C_2 . From (173) we obtain the four pairs of equations needed to determine the two constants:

$$177. \quad C_2 - qy_{\min} = \frac{a}{2} \cdot y_{\min}^2 + C_1,$$

$$C_2 - qy_{\max} = \frac{a}{2} \cdot y_{\max}^2 - C_1.$$

$$178. \quad C_2 - qy_{\min} = \frac{a}{2} \cdot y_{\min}^2 - C_1,$$

$$C_2 - qy_{\max} = \frac{a}{2} \cdot y_{\max}^2 + C_1.$$

$$179. \quad C_2 - qy_{\min} = -\frac{a}{2} \cdot y_{\min}^2 - C_1,$$

$$C_2 - qy_{\max} = -\frac{a}{2} \cdot y_{\max}^2 - C_1.$$

$$180. \quad C_2 - qy_{\min} = \frac{a}{2} \cdot y_{\min}^2 + C_1,$$

$$C_2 - qy_{\max} = \frac{a}{2} \cdot y_{\max}^2 + C_1.$$

From the first pair of equations we obtain

$$181. \quad -C_1 = \frac{a}{4} (y_{\max}^2 + y_{\min}^2) - \frac{q}{2} (y_{\max} - y_{\min}).$$

$$182. \quad C_2 = -\frac{a}{4} (y_{\max}^2 - y_{\min}^2) + \frac{q}{2} (y_{\max} + y_{\min}).$$

These equations, as we shall see, apply to an ordinary ponderable envelope, or, in general, whenever the light gas or fluid inside the envelope tends, as it were, in a direction opposite to that of gravity. Such is the case in relation to the aerostat.

From the second pair of equations we have

$$183. \quad -C_1 = \frac{a}{4} (y_{\max}^2 + y_{\min}^2) + \frac{q}{2} (y_{\max} - y_{\min}).$$

$$184. \quad C_2 = \frac{a}{4} (y_{\max}^2 - y_{\min}^2) + \frac{q}{2} (y_{\max} + y_{\min}).$$

These equations apply to negative ponderability or, in general, whenever the apparent tendency of the fluid inside the envelope is to move in the direction of gravity. This is the case when we determine the shape of a cylindrical bag filled with a fluid or gas heavier than the surrounding medium, for example, air.

It is not possible to determine the constants from the third and fourth pairs of equations, but we then get

$$185. \quad y_{\min} = \frac{q}{a} - \frac{y_{\max} - y_{\min}}{2}, \quad \text{or} \quad y_3 = \frac{q}{a} - \frac{h}{2}.$$

$$186. \quad y_{\min} = -\frac{q}{a} - \frac{y_{\max} - y_{\min}}{2}, \quad \text{or} \quad y_3 = -\frac{q}{a} - \frac{h}{2}.$$

187. Suppose that when the derivative $\left(\frac{dh}{dx}\right)$ is equal to infinity, $y - y_3 = h_1$ (Fig. 12); then from equation (173) we find:

$$h_1 + y_3 = \sqrt{\frac{-2C_1}{a}}.$$

Clearly then, C_1 must be negative.

It is also apparent, on the basis of equations (181) and (183), that h_1 will be smaller for positive than for negative ponderability

(Fig. 15).

Likewise, it is not difficult to show that in the case of an infinitely large pressure p at the low-point of the envelope ($y_3 = \infty$)

$h_1 = \frac{h}{2}$, for both in positive and negative ponderability, which serves

as a check on the formulas.

188. By eliminating C_1 from this last equation, we find:
in the case of positive ponderability (aerostat):

$$h_1 + y_{\min} = \sqrt{\frac{1}{2} (y_{\max}^2 + y_{\min}^2) - \frac{q (y_{\max} - y_{\min})}{a}},$$

and in the case of negative ponderability

$$h_1 + y_{\min} = \sqrt{\frac{1}{2} (y_{\max}^2 + y_{\min}^2) + \frac{q (y_{\max} - y_{\min})}{a}}$$

189. When the envelope is imponderable, i.e., $q = 0$, we have

$$h_1 + y_{\min} = \sqrt{\frac{1}{2} (y_{\max}^2 + y_{\min}^2)}.$$

The greater the value of y_3 , the less h_1 compared to h ; so that when $y_3 = 0$

$$h_1 = \frac{h}{\sqrt{2}} = \frac{h}{2} \sqrt{2}.$$

190. The usual formula enables us to find the radius of curvature of the unknown curve. Using equations (170) and (172), we find

$$\left(\frac{dy}{dz}\right)^2 = \left(\frac{C_2 - qy}{\frac{a}{2} \cdot y^2 + C_1}\right)^2 - 1.$$

191. Now

$$\frac{ds}{dz} = \pm \sqrt{1 + \left(\frac{dy}{dz}\right)^2} = \pm \frac{C_2 - qy}{\frac{a}{2} \cdot y^2 + C_1}.$$

192. From equations (166), we obtain

$$-\frac{d^2y}{dz^2} = \frac{q \cdot \frac{ds}{dz} + ay \left[\left(\frac{dy}{dz}\right)^2 + 1 \right]}{\frac{a}{2} y^2 + C_1}.$$

193. Finally, from this and the preceding equations, we find the radius of curvature ρ :

$$\rho = \frac{\left(\frac{ds}{dz}\right)^3}{\frac{d^2y}{dz^2}} = \frac{\pm (C_2 - qy)^2}{q \left(\frac{a}{2} y^2 + C_1\right) + ay (C_2 - qy)}.$$

194. We recall that q is the weight of unit length of the envelope for unit width; a is the difference between the densities of the internal and external fluids, equal to $\gamma_{\text{air}} - \gamma_{\text{gas}}$; ay_3 expresses the pressure at the low-point of the envelope; ay is the pressure at the level y ; C_1 and C_2 are constants determined from equations (181) and (182) in the case of ordinary positive ponderability, and from equations (183) and (184) in the case of negative ponderability.

195. Consider the circular cross section of a cylindrical aerostat of height h^* . The buoyancy of this circular cylinder will be $\frac{\pi h^2}{4} \cdot a$. Let $1/n$ be the part of this buoyancy corresponding to the weight of the envelope of the (open, of course) cylinder. We then have

$$\frac{1}{n} \cdot \frac{\pi h^2}{4} \cdot a = \pi h q,$$

and hence

*The width of the cylinder is assumed to be equal to unity.

$$q = \frac{ah}{4n}$$

196. My object is to introduce a rough approximation of the fact that the weight of the envelope corresponds to a certain fraction ($1/n$) of the buoyancy of the aerostat.

On eliminating q from the constants C_1 and C_2 and from equation (193), and on eliminating the constants themselves from the last equation and replacing the expressions y_{\max} and y_{\min} by their numerical values ($y_{\max} = h + y_3$ and $y_{\min} = y_3$) (Fig. 15), we obtain for the aerostat (positive ponderability)*:

$$\rho = \frac{h \left(1 + \frac{2y_3}{h} - \frac{1}{2n} + \frac{y - y_3}{n \cdot h}\right)^2}{\frac{2}{n} \left(\frac{y}{h}\right)^2 - \frac{1}{n} \left(1 + \frac{2y_3}{h} + \frac{2y_3^2}{h^2} - \frac{1}{2n}\right) - 4 \frac{y}{h} \left(1 + \frac{2y_3}{h} - \frac{1}{2n} + \frac{y - y_3}{nh}\right)}$$

197. Likewise, for a gas heavier than air, or for a bag containing a liquid, say water, we find

$$\rho = \frac{h \left(1 + \frac{2y_3}{h} + \frac{1}{2n} - \frac{y - y_3}{nh}\right)^2}{\frac{2}{n} \cdot \left(\frac{y}{h}\right)^2 - \frac{1}{n} \left(1 + \frac{2y_3}{h} + \frac{2y_3^2}{h^2} + \frac{1}{2n}\right) + 4 \cdot \frac{y}{h} \left(1 + \frac{2y_3}{h} + \frac{1}{2n} - \frac{y - y_3}{nh}\right)}$$

*I.e., ordinary gravity.

198. Clearly, from these equations, the curve has a very complex form, and its shape will depend on the relative massiveness ($\frac{1}{n}$) of the envelope and on the relative pressure y_3/h at the low-point of the envelope. If these quantities are constants, then the curves will all be similar. Of course, the shape of the curve will also depend on the direction of gravity with respect to the direction of the gas pressure, as will be obvious from the differences between the last two equations.

199. When $\frac{y_3}{h} = \infty$, both equations state that the radius of curvature is constant and equal to $h/2$ (half the envelope height), i.e., the curve reduces to a circle.

200. According to the first equation, for an aerostat such that $n = 1$, i.e., when the weight of the envelope is equal to the buoyancy of the gas, the curve will also reduce to a circle for any pressure y_3 at the low-point, since the first equation gives $\rho = 1/2 h$.

We arrive at the same conclusion when we find the derivatives, etc. from the equation of a circle relative to its tangent, and substitute in equation (166). We find that this equation is satisfied; therefore, when $n = 1$ and the ponderability is positive, the curve will be a circle.

Let us now put $n = 2$ in equation (196) and give the ratio y_3/h the values: 0; 1/8; 0.14; 0.15; 1/5; 1/4; 1/2; 1, successively.

We then obtain the following formulas for computing the radii of curvature of the curves bounding the cross section of the aerostat. For the sake of brevity, in these formulas I have introduced

the abbreviated notation $\frac{y - y_3}{h} = k$, but since h , or the envelope height, has been made equal to unity, we have $y - y_3 = k$.

For different values of k , we obtain different radii; these are tabulated below:

$$\frac{y_3}{h} = 0; \quad \rho = \frac{(3 + 2k)^2}{16k + 6}; \quad n = 2$$

k	0	0.2	0.5	1.0
ρ	1.500	0.714	0.471	0.357

201. $\frac{y_3}{h} = \frac{1}{8}; \quad \rho = \frac{(2 + k)^2}{4k(4 + k) + 4}; \quad n = 2$

k	0	0.2	0.5	1.0
ρ	1.000	0.658	0.480	0.375

202. $\frac{y_3}{h} = 0.14; \quad \rho = \frac{(2.06 + k)^2}{4k(4.12 + k) + 4.31}; \quad n = 2$

k	0	0.2	0.5	1.0
ρ	0.984	0.657	0.484	0.378

203. $\frac{y_3}{h} = 0.15; \quad \rho = \frac{(2.1 + k)^2}{4k(4.2 + k) + 4.62}; \quad n = 2$

k	0	0.2	0.5	1.0
ρ	0.955	0.650	0.482	0.378

There is nothing easier than to construct very accurate curves from even these few radii; but let us proceed.

$$204. \quad \frac{y_3}{h} = \frac{1}{5}; \quad \rho = \frac{(2.3 + k)^2}{4k(4.6 + k) + 5.98}; \quad n = 2$$

k	0	0.2	0.5	1.0
ρ	0.885	0.636	0.485	0.384

$$205. \quad \frac{y_3}{h} = \frac{1}{4}; \quad \rho = \frac{(5 + 2k)^2}{16k(5 + k) + 30}; \quad n = 2$$

k	0	0.2	0.5	1.0
ρ	0.833	0.617	0.486	0.389

$$206. \quad \frac{y_3}{h} = \frac{1}{2}; \quad \rho = \frac{(7 + 2k)^2}{16k(7 + k) + 70}; \quad n = 2$$

k	0	0.2	0.5	1.0
ρ	0.700	0.589	0.492	0.404

$$207. \quad \frac{y_3}{h} = 1; \quad \rho = \frac{(11 + 2k)^2}{16k(11 + k) + 198}; \quad n = 2$$

k	0	0.4	1.0
ρ	0.611	0.514	0.433

208. Using these data, we are able to construct the curves arrived at earlier by experimental means (Fig. 16).

An inspection of these curves shows that they all resemble elongated cycloids (Fig. 15). We also see that the pressure y_3/h at

the low-point cannot be less than 0.237, for otherwise the curve would not be closed, i.e., it would not cut the ordinate axis. Clearly, moreover, the curve will round out more and more as the pressure at the low-point rises, but the double (or full) width will nevertheless appreciably exceed the height.

209. If we construct curves on the basis of formula (197), we see that the bag containing some gas or fluid heavier than air will have the same curves in its cross section, except that they will be turned upside down. Note likewise that the curves are less elongated in the horizontal direction than the curves of the aerostat, and require an incomparably greater pressure y_3/h at the low-point.

210. The curves for a weightless envelope occupy a middle position; their properties are intermediate, i.e., they are characterized by intermediate elongation in the horizontal direction and require an intermediate pressure at the low-point of the envelope.

211. The dependence of the shape of the aerostat envelope on the relative ponderability $1/h$ of the envelope, given the same pressure at the low-point, is also readily seen. For example, if $y_3/h = 1/2$, and n is successively 1, 2, and ∞ (or if the ponderability $1/n$ of the envelope is respectively 1; $1/2$, or 0), we can construct three curves on the basis of equation (196). The first curve will be a circle and then, as $1/n$ decreases, the curve will become increasingly elongated in the horizontal direction.

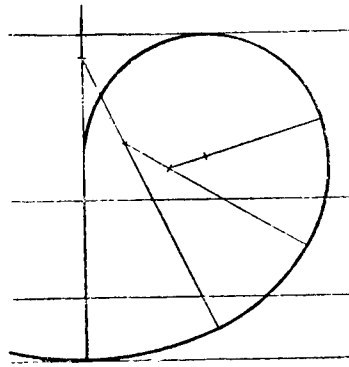

Fig. 16

212. For the construction of weightless envelopes, we can now derive some extremely simple formulas by putting $n = \infty$ in equations (196) or (197).

We then obtain

$$\rho = \frac{c_2}{ay}.$$

If, on the other hand, we put $q = 0$ in equations (183) and (184), we obtain

$$- C_1 = \frac{a}{4} [y_{\max}^2 + y_{\min}^2].$$

$$C_2 = \frac{a}{4} [y_{\max}^2 - y_{\min}^2].$$

213. Accordingly:

$$\rho = \frac{h}{4} \cdot \frac{y_{\max} + y_{\min}}{y}.$$

or

$$\rho = \frac{h}{4} \cdot \frac{h + 2y_3}{y}.$$

214. Using equations (196) and (197), if $n = \infty$, we arrive at exactly the same result:

$$\rho = \frac{\left(1 + \frac{2y_3}{h}\right)^2}{4 \frac{y}{h} \left(1 + \frac{2y_3}{h}\right)} = \frac{h}{4} \cdot \frac{h + 2y_3}{y}.$$

215. Clearly, from the last formulas, as the ordinate y increases the radius of curvature continuously decreases. When $y = y_3$, ρ will be a maximum; then

$$\rho_{\max} = \frac{h}{2} \left(\frac{h}{2y_3} + 1 \right).$$

When $y = h + y_3$, we obtain the maximum curvature, namely:

$$\rho_{\min} = \frac{h}{4} \left(1 + \frac{y_3}{h + y_3} \right).$$

The ratio

$$\frac{\rho_{\max}}{\rho_{\min}} = \frac{h}{y_3} + 1.$$

216. If, moreover, $y_3 = 0$ (i.e., the pressure is zero at the low-point), then the radius of curvature ρ will range from infinity to $h/4$.

217. As y_3 increases, or as the pressure at the low-point increases, the radius ρ will decrease at the bottom and increase at the top. When y_3 is infinitely great, of course, the curve must become a circle, and, in fact, we find from formula (213) that $\rho = 1/2 h$, i.e., we obtain a constant radius equal to half the height h of the envelope.

218. Formulas (196) and (197) are entirely adequate for very accurate tracing of the cross section of the aerostat and for the experimental investigation of the curves in all respects and details.

Nevertheless, I shall also present some theoretical data for the same purpose. The derivative $\left(\frac{dy}{dz}\right)$ is expressed by formula (173); for the determination of the curve we have formula (174).

219. Below I offer the second derivative:

$$-\frac{d^2y}{dz^2} = \frac{(C_2 - qy) \left[ay (C_2 - qy) + q \left(\frac{a}{2} y^2 + C_1 \right) \right]}{\left(\frac{a}{2} y^2 + C_1 \right)^3}.$$

220. Further, I shall give the differential of the arc ds :

$$\frac{ds}{dy} = \sqrt{1 + \left(\frac{dz}{dy}\right)^2}$$

or, using equation (173), we have

$$ds = \frac{(C_2 - qy) dy}{\sqrt{(C_2 - qy)^2 - \left(\frac{a}{2} y^2 + C_1\right)^2}}.$$

221. Finally, the differential of the cross-sectional area is $(y - y_3) dz$; consequently:

$$(y - y_3) dz = \frac{\left(\frac{a}{2} y^2 + c_1\right) (y - y_3) dy}{\sqrt{(c_2 - ay)^2 - \left(\frac{a}{2} y^2 - c_1\right)^2}}.$$

222. The equations of this chapter may also be applied, with other constants, to a different method of suspending the gondola; they may also be used to determine the shape of the cross section of a variably inflated aerostat, when the bottom of the envelope forms a re-entrant or salient angle.

VII. THE CORRUGATED METAL SKIN OF THE AEROSTAT.

STRETCHING AND BENDING OF THE SURFACE¹Surface of Revolution Transformed into a Double Plane

In addition to the one described in Chapter V, there is yet another type of corrugated aerostat envelope. Accordingly, I shall proceed to derive certain formulas relating to the corrugated surface of an aerostat needed for constructing this surface in accordance with some specific system.

223. First let us suppose that the aerostat has the shape of the surface obtained by rotating some smooth curve about its chord (Fig. 17).



Fig. 17.

¹A portion of this chapter is taken from my book Aerostat metallicheskiy, upravlyaemyy [The Maneuverable Metal Aerostat] (1892, 1893).

We can now transform this surface in such a manner as to obtain the desired properties (Chapter V).

To do this, we divide the surface into a large number of parts by means of planes perpendicular to its longitudinal axis (Fig. 18). Each part may be regarded, with no great error, as the lateral surface of a truncated cone; the ends of the aerostat however, represent the lateral surfaces of complete cones.

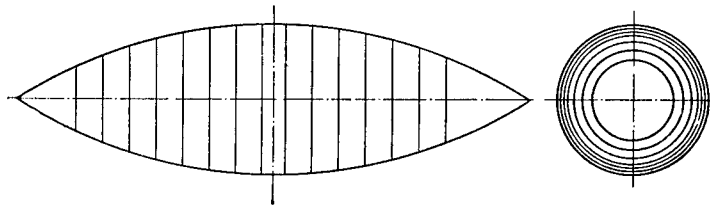

Fig. 18.

224. Conical surfaces have the property that they can be folded flat without wrinkling. We now flatten all the cones in the same order in which they were originally arranged and attempt to lay them out so that there are no gaps between neighboring cones yet no cone overlaps its neighbor. This we can never achieve (Fig. 19). Along the center-line of the drawing, the folded conical surfaces do not meet; the closer we get to the edges of the figure and further they move apart; these surfaces, of course, are understood to be double surfaces.

Had the edges of the gaps in the last drawing been parallel, it would have been possible to bring the surfaces closer together and make them continuous.

225. Now suppose that the strips (Fig. 19) are extremely narrow and that the gaps between the strips are likewise narrow. We now bend each strip to form a trough or ridge. The troughs should be deeper, and the ridges higher, along the longitudinal axis of the drawing, growing shallower or lower as we proceed further out from the center-line. Then the middle portions of the strips

will undergo a transverse contraction, and the edges of the gaps will be equidistant. Thus, we shall be in a position to make those edges meet. The end cones (Fig. 19) remain unchanged.

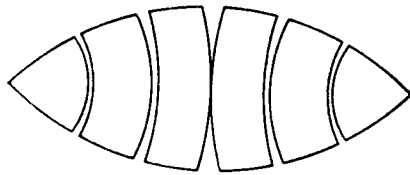

Fig. 19.

226. Thus, the aerostat is first cut up into narrow strips, these strips are folded flat and given a trough-like shape, and, finally, the edges are brought together, i.e., those points on the surface of the aerostat which were previously in contact are re-matched.

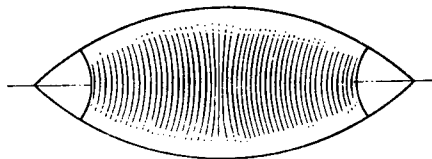

Fig. 20.

As a result, we have an aerostat (Fig. 20) which is cleverly and continuously folded flat and covered with transverse corrugations. These corrugations are the deeper the closer they are to the

center-line of the folded metal bag; only the edges of the latter and the hollow end cones are perfectly flat. When the bag is inflated, these corrugations are more or less smoothed out, i.e., the depth of the corrugations is reduced. But it will not be possible to inflate the aerostat completely or to smooth out the corrugations completely without breaking the skin. The waves in the surface must therefore be steeper, so that they will not be completely smoothed out when the envelope is fully inflated; in the first place the extra fullness of the waves is no disadvantage; secondly, it enables the surface freely to take on the shape corresponding to the cross section depicted in Fig 1 and to vary that shape appreciably.

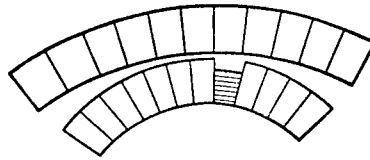

Fig. 21.

227. If we assume that the waves in the envelope are sufficiently shallow, and that the aerostat itself is sufficiently large and made of sufficiently thin and elastic material, then the metal bag thus obtained will have the properties referred to above. To these properties we may add another, viz. a special elasticity, so that the aerostat "springs back," despite considerable changes in shape or volume, without forming irregular and unexpected folds and offers adequate resistance to any forces tending to make it collapse.

228. Even though the above concept of the design of a folding metal aerostat is highly useful for clarifying its capacity to change shape in response to the forces acting on it, in practice the aerostat will probably have to be made of panels, so I shall now suggest an alternative method of plane construction.

Suppose we take two adjacent folded conical surfaces and divide them into panels in the manner shown in Fig. 21. If we pass

each such panel through a pair of toothed rollers, i.e., through a pair of cylinders covered with corrugations the crests of which are aligned parallel to the axes of the cylinders, then the length of the panels will be reduced [Fig. 22]*.

By employing rollers with corrugations of different depths and also by moving the rollers slightly apart, we can shorten the panels by different amounts without varying the number of corrugations impressed on all panels of the same size.

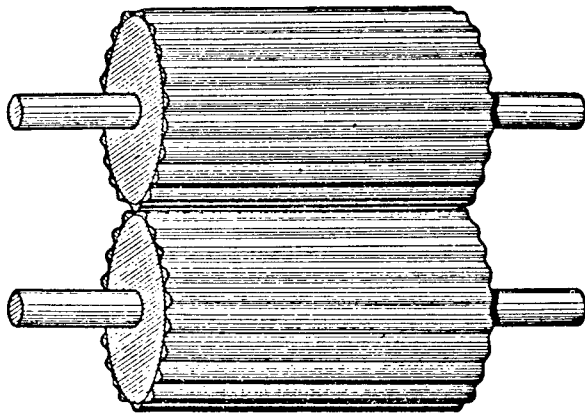

Fig. 22.

229. The panels can also be reduced in size in such a way that the edges of the gaps between them are parallel when the panels are rearranged in their former positions (Fig. 21); this, of course, requires that the panels be given corrugations that are parallel to the strip, and the steeper the closer they come to the

*Square brackets are always reserved for additions made by the editor

center-line of the folded aerostat.

It then remains to bring together and rejoin all those points on the aerostat that were originally in contact.

The shape, of course, will be exactly the same (Fig. 20) as that described in connection with the other method of forming a folded metal bag.

230. Not all the rings (or strips) need be corrugated; it would be sufficient to corrugate alternate rings.

Geometrical Calculations

Now let us proceed to the calculations. I shall first work through the purely geometrical calculations, later the mechanical calculations as well. To start with, we need to know the radii and angles of the cones forming the gas envelope, as well as the gaps between adjacent strips (Fig. 19); once these gaps are known, it is not difficult to determine the extent to which they must be reduced in order for the strips to fit side by side in a single plane, thus forming a closed envelope.

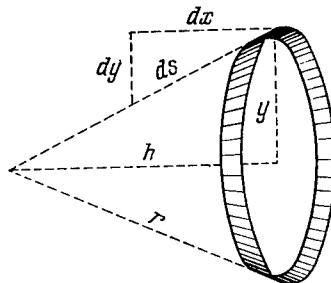

Fig. 23.

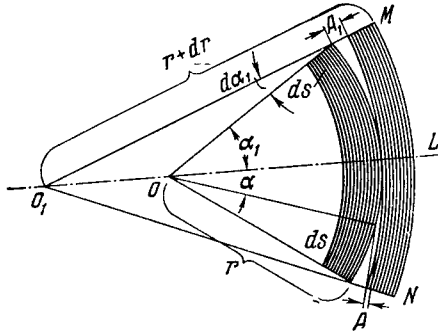

Fig. 24.

231. Suppose that the equation of the curve (Fig. 17) generating the surface of the aerostat upon rotation about its chord is $y = F(x)$; here we take the chord as the α axis, and its center as the origin of the rectangular coordinates. Then, from Fig. 23, where one of the truncated cones is shown in its natural i.e., unfolded form, and where r is the tangent to the curve, or the generatrix of the complete cone, h is the height of the cone, and y is the radius of its base, we find

$$232. \quad \frac{dy}{dx} = \frac{y}{h} \quad \text{and} \quad r^2 = h^2 + y^2;$$

hence

$$233. \quad r = y \left[1 + \left(\frac{dx}{dy} \right)^2 \right]^{\frac{1}{2}}.$$

We have determined the generatrix r of the complete cone, or the radius of the folded truncated cone, which looks like part of a ring (Fig. 24). From the drawing, we now find the length of the arc ML:

$$234. \quad ML = \frac{2\pi y}{4} = \frac{\pi y}{2} .$$

Consequently, writing 360° as 2π , we have the following expression for the angle α subtended by the arc ML:

$$235. \quad \alpha_1 = \frac{MN}{r} = \frac{\pi y}{2r} .$$

On the basis of this last equation and equation (233), we arrive at

$$236. \quad \alpha_1 = \frac{\pi}{2} \left[1 + \left(\frac{dx}{dy} \right)^2 \right]^{\frac{1}{2}} .$$

We now have to find the size of the edge gap (i.e., at its widest point for a given pair of folded strips) between two cones folded flat (Fig. 24), which we denote as A_1 .

Having examined Fig. 24, where r is the outside radius of one strip, $(r + dr)$ the outside radius of the adjacent strip and ds the width of the strip,

$$237. \quad ds = \left[1 + \left(\frac{dx}{dy} \right)^2 \right]^{\frac{1}{2}} dx,$$

we can formulate the following equation:

$$238. \quad (r+dr) \cos(\alpha - d\alpha) + r \cos(d\alpha) + A + ds = \\ = r \cos \alpha + r + A + ds.$$

239. But

$$(r + dr) - r - ds = dr - ds.$$

240. Therefore:

$$A = \left(\frac{dr}{dx} - \frac{ds}{dx} \right) \cdot (1 - \cos \alpha) dx.$$

Here the angle α is found from formula (236); but the angle may be less than α , and we then find not the widest gap A at the edge of the folded strip, but other lesser values A lying closer to the center C (Fig. 24); thus, formula (240) holds true in general; we therefore have

$$241. \quad A = \left(\frac{dr}{dx} - \frac{ds}{dx} \right) (1 - \cos \alpha) dx;$$

here the angle α is not entirely arbitrary, but must satisfy the condition

$$242. \quad \alpha \leq \frac{\pi}{2} \left[1 + \left(\frac{dx}{dy} \right)^2 \right]^{\frac{1}{2}},$$

i.e., it must be less than α_1 (236).

243. Once A_1 and A are known, it is readily seen that the shortening of an individual panel dA forming an element of the strip (just as the latter in its turn forms an element of the aerostat) is: $dA = A_1 - A$, i.e., it is equal to the greatest gap between the given pair of strips minus the gap corresponding to the position of the given panel.

244. If the equation of the generatrix (Fig. 17) of the gas envelope is known, then, however complicated its shape may be, we are in a position to find out, from the above equations, the radii r of the strips (233), their length (234), their angles (236), the gaps A_1 and A (241) and (240), and the shortening dA of the panels that form second-order elements of the aerostat.

245. We see from equation (241) that, for a particular strip, or for a constant value of the coordinate x , the gap A is pro-

*Not greater than α_1 .

portional to $1 - \cos \alpha$, but we have approximately $1 - \cos \alpha = \frac{\alpha^2}{2}$,

i.e., the gap is proportional to the square of the angle α or to the distance from the center point L along the arc MN (Fig. 24), regardless of the shape of the generatrix or the form of its equation (231).

246. The equations we derived, which contain the radius r (233) and the arc s , are quite complicated. But for our initial purposes they can be simplified. The corrugations of the envelope surface do not require to be calculated with special accuracy, since they are made with a safe margin of tensile strength; thus the simplified expressions will also be suitable for designing the envelope.

We have approximately [Fig. 23 and formula (233)], provided the aerostat is fairly elongated:

$$247. \quad r = h = y \cdot \frac{dx}{dy};$$

$$248. \quad \frac{ds}{dx} = 1.$$

From (247), on differentiating, we find

$$249. \quad \frac{dr}{dx} = 1 - y \left(\frac{dx}{dy} \right)^2 \cdot \frac{d^2y}{dx^2}.$$

Hence,

$$250. \quad \frac{dr}{dx} - \frac{ds}{dx} = -y \left(\frac{dx}{dy} \right)^2 \frac{d^2y}{dx^2}.$$

Moreover, from (236) and (245) we get, approximately:

$$251. \quad \alpha_1 = \frac{\pi}{2} \cdot \frac{dy}{dx},$$

$$252. \quad 1 - \cos \alpha_1 = \frac{\alpha_1^2}{2} = \frac{\pi^2}{8} \left(\frac{dy}{dx} \right)^2.$$

Now, from (240) we find

$$253. \quad A_1 = \frac{-\pi^2}{8} \cdot y \cdot \frac{d^2y}{dx^2} \cdot dx.$$

$$254. \quad \text{If, for instance, } y = F(x) = y_1 \left(1 - \frac{x^2}{x_1^2} \right), \text{ i.e., if}$$

the aerostat is formed by rotating the arc of a parabola about a chord $2x_1$ perpendicular to the axis of the parabola, then we obtain

the following approximation for the edge gap A_1 :

$$A_1 = \frac{\pi^2 y_1^2}{4x_1^2} \left(1 - \frac{x^2}{x_1^2} \right) dx = \frac{\pi^2}{4} \cdot \frac{y_1^2}{x_1^2} \cdot \frac{y}{y_1} \cdot dx.$$

Here, as in the preceding equation, $2x_1$ is the length of the

envelope, and $2y_1$ is the height of the envelope, or its greatest diameter.

255. The formula clearly shows that A_1 is proportional to $2y_1$, i.e., to the diameter of the cross section of the envelope and to the width dx or ds of the strip for a given aerostat. Near the ends of the envelope, the gap between the strips will be so small that at the ends of the envelope the corrugations can be safely neglected and these areas can be made smooth and conical.

256. It is clear from the same formula that for constant x_1/x_1 and dx_1 but envelopes with different aspect ratios x_1/y_1 the quantity A_1 will be inversely proportional to the square of the aspect ratio. For example, if the aspect ratio of the envelope were tripled, while retaining the same equation of the curve, then the gaps between strips A_1 would be reduced 9 times.

257. The last formula also gives us the greatest relative shortening A_1/dx_1 of the panel (Fig. 21, 24). Putting the envelope aspect ratio x_1/y_1 equal to 7 in this formula, and assigning to x_1/x_1 successive values of 0, $1/2$, $3/4$, and 1, for the relative shortening A_1/dx_1 our calculations give: $1/20$, $1/26$, $1/46$, $1/85$, and 0.

258. When the envelope has the shape of an ellipsoid of revolution, then

$$y = F(x) = y_1 \sqrt{1 - \frac{x^2}{x_1^2}}$$

and

$$\frac{A_1}{dx} = \frac{\frac{\pi^2}{8} \cdot \frac{y_1^2}{x_1^2}}{\left(1 - \frac{x^2}{x_1^2}\right)} = \frac{\pi^2}{8} \cdot \frac{y_1^2}{x_1^2} \cdot \frac{y_1^2}{y^2} .$$

This makes it clear that in the case of an ellipsoid, the value of A_1/dx for the edge gap, or the greatest shortening of the panel, will increase rapidly toward the ends of the envelope. Again assuming $x/y = 7$, and x/x_1 equal successively to: 0, 1/5, 2/5, 3/5, 4/5, we find the corresponding values for A_1/dx : 1/40, 1/38, 1/34, 1/26, and 1/14.

259. If we assume

$$y = F(x) = y_1 \left(1 - \frac{x^2}{x_1^2}\right)^{\frac{3}{4}},$$

where the exponent $3/4$ is the arithmetic mean of the exponents [degrees] of the equations of the two preceding curves, we find:

$$\frac{A_1}{dx} = \frac{3\pi^2}{32} \cdot \frac{y_1^2}{x_1^2} \cdot \frac{x_1^2}{\sqrt{1 - \frac{x^2}{x_1^2}}} .$$

Again putting $x/y = 7$ and x/x equal successively to:
 $0, 1/5, 2/5, 3/5, 4/5$, we find for A_1/dx the values: $1/26, 1/26,$
 $1/25.5$, and $1/22$, respectively.

Consequently, we can also get envelopes shaped so that the edge gap is approximately the same from the nose to the tail of the aerostat.

260. For an elongated cosinusoid

$$y = F(x) = y_1 \cos\left(\frac{\pi x}{2x_1}\right)$$

and

$$\frac{A_1}{dx} = \frac{\pi^4}{32} \cdot \left(\frac{y}{x_1}\right) \cdot \left(\frac{y_1}{x_1}\right) \cdot \cos\left(\frac{\pi x}{2x_1}\right) = \frac{\pi^4}{32} \cdot \frac{y^2}{x_1^2} \cdot$$

This means that the edge gap will be reduced at an extremely rapid pace toward the ends of the envelope and, in fact, will be proportional to the square of the diameter $2y$ of the envelope cross section. This gives a very smooth, sharply tapered, and well streamlined shape.

261. This last formula may be written as:

¹
 I have designed high-speed boats with just this shape.

$$\frac{A_1}{dx} = \frac{\pi^4}{32} \left(\frac{y_1}{x_1} \right)^2 \left(\frac{y}{y_1} \right)^2 .$$

Hence it is clear as we also found in the case of other surfaces, that the value of A is inversely proportional to the square of the envelope aspect ratio.

The greatest edge gap is obtained from this last equation by substituting $y = y_1$. We thus find $\frac{A_1}{dx} = \frac{\pi^4}{32} \left(\frac{y_1}{x_1} \right)^2$. When $\frac{x_1}{y_1} = 7$,

we have $\frac{A_1}{dx} = 0.06212$, or about $1/16.3^*$.

Actually, in the middle of the envelope, the gap will be far greater, compared to the other shapes, but in contrast it will be reduced rapidly toward the ends of the envelope.

262. We can also make $\frac{A_1}{dx} = F(y)$, i.e., make the relative shortening of the center panel or the edge gap chosen functions of the coordinate y .

We then obtain the differential equation (cf. (253))

$$-\frac{\pi^2}{8} \cdot y \cdot \frac{d^2 y}{dx^2} = F(y) ,$$

or

*1/16.1, to be more precise.

$$\frac{d^2y}{dx^2} = \frac{-8}{\pi^2} \cdot \frac{F(y)}{y} .$$

Hence

$$x = \int \frac{dy}{\sqrt{C - \frac{16}{\pi^2} \int \frac{F(y)}{y} \cdot dy}},$$

where C is a constant.

263. If, for example, $F(y) = ky$, where k is some constant multiplier, then

$$\int dy = y$$

and

$$x = \int \frac{dy}{\sqrt{C - \frac{16}{\pi^2} ky}} = \frac{-\pi^2}{8k} \sqrt{C - \frac{16}{\pi^2} ky + C_1},$$

where C is also a constant.

1
This is, of course, the equation of a parabola, as we have seen earlier.

Mechanical Calculations

264. Let us now consider the mechanical aspects of the problem of designing the metal envelope of an aerostat.

We have learned that each panel must be shortened by a certain amount (A - A), and that this can be done by corrugating the sur-

face in the machine illustrated in Fig. 22. Then, when arranged in the proper order, correctly aligned and welded together, the panels will form a flat bag which, on being inflated, will assume a streamlined shape (like that of a fish or a spindle) with no irregular or unexpected wrinkles likely to impair its integrity.

But the panels could be shortened by means of either shallow or deep folds or corrugations (Fig. 25). The question is what size should these corrugations be?

It is imperative that the corrugations, the crests of which define the cross section of the aerostat, be free to bend as the aerostat passes from the flat to the round inflated form, with no danger of fracturing or cracking or the formation of irregular folds.

This condition calls for the shallowest possible corrugations; but very shallow corrugations would not be of much use for the simple reason that, as the aerostat is inflated and the corrugations flatten out (i.e., as their depth is reduced), they must not only not crack, but must be elastic enough to spring back into their original form when the aerostat is deflated.

This second condition calls not only for highly elastic material but also for the deepest possible corrugations.

265. Thus, we can now proceed to determine the maximum dimensions of the corrugations, for the time being solely from the standpoint of safe transverse bending of the aerostat surface.

In order that the bending of the corrugated peripheral surface of the cross section of the aerostat may be viewed as that of a massive plate of thickness $2h$, smaller second-order corrugations will have to be formed in the ordinary [or first-order] corrugations whenever the size of these corrugations is much greater than the thickness of the sheet metal of which the panel is made, and smaller or third-order corrugations may have to be formed in these second-order corrugations, and so on. It is my belief that in practice we need not go beyond the use of ordinary first-order corrugations in normal aerostat design, or in the worst case second-order corrugations (Fig. 26). This task can be handled with machines similar to

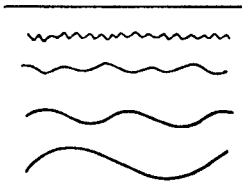

Fig. 25.



Fig. 26.

the one illustrated in Fig. 22. Suppose that a massive surface of thickness $2h$ is bent into a circle of length C ; then the convex side of the resulting cylinder will be stretched by an amount dC , while the concave side will be shortened by the same amount; clearly, the ratio dC/C must not exceed the ratio K/E where K is the elastic limit of the material (i.e., the stress at which the material fails to resume its original shape when the applied forces are removed and tends to rupture) and E is the modulus of elasticity, so that the ratio K/E expresses the limiting elongation per unit length of material. We have

$$267. \quad \frac{dC}{C} \leq \frac{K_e}{E} ;$$

where

$$268. \quad C = 2\pi r ;$$

accordingly, on differentiating we have:

$$269. \quad dC = 2\pi dy$$

and therefore, dividing (269) by (268), we get

$$270. \quad \frac{dC}{C} = \frac{dy}{y} \leq \frac{K_e}{E};$$

whence, noting that $dy = h$, we obtain

$$271. \quad h < y \cdot \frac{K_e}{E}.$$

Of course, y and h consequently h are variables even for the same aerostat and proportional to the diameter of the cross section. The depth of the corrugations

$$272. \quad h = y \cdot \frac{K_e}{E}$$

is perfectly safe, since the true depth diminishes steadily as the walls of the aerostat stretch and the folds in the envelope straighten out, hence the danger of rupture likewise steadily decreases; then the true depth of the corrugations is not constant but decreases as

the distance from the center-line (Fig. 20) of the metal envelope increases.

273. We have determined the maximum depth h from the standpoint of the cross-sectional dimensions of the aerostat; we shall now determine this depth from the standpoint of the elastic longitudinal stretching of the corrugated surface of the aerostat; to be precise, we shall seek to determine the least depth h that the corrugations can have and still be able to stretch by a certain fraction A/dx of their length, when formed in sheet metal of thickness δ , and then to return to the earlier value y as the effect of the tensile force decreases.

Let Fig. 27 represent part of a corrugation between the center-line and the crest. Assuming, for convenience, that the corrugations are arranged horizontally, we designate by $2z$ the variable depth of the corrugation from the high point to the low point; the corresponding constant depth (when the corrugated surface is no longer subject to tensile forces) may be designated $2h$; finally, the wavelength from the high point to the adjacent low point may be designated $2L$. Clearly, from Fig. 27, the depth of the corrugation comprises only a small fraction of the wavelength¹, so that, in spite of any second-order waves -- provided only that these are similar in shape to the principal waves -- we have, approximately:

$$274. \quad V = H \cdot \frac{z}{L} \cdot$$

which expresses the relationship between the longitudinal force H and the normal force V that act to bend the plate into the position depicted in Fig. 27.

Let us consider the effect of the normal force. Figure 28 shows a plate of thickness δ and unit width.

¹ Usually the wavelength is understood to be twice this length or $4L$.

275. A fairly simple integration yields the formula $\frac{\epsilon E \delta}{3}$ for the action of the force on the lever arm $\delta/2$ (Fig. 28) for a relative elongation ϵ of the surface portions of the bent plate¹. This force (275) is balanced by another force V acting on a lever arm of

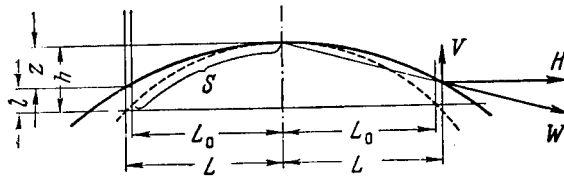

Fig. 27.

length x ; consequently, in accordance with the laws of statics, we have

$$276. \quad Vx = \left(\frac{\epsilon E \delta}{3} \right) \cdot \frac{\delta}{2},$$

or

$$277*. \quad V = \frac{\epsilon E \delta^2}{6x}.$$

¹ ϵ is the elongation per unit length of the surface layer, or $\frac{\sigma}{E}$ [cf. (265)].

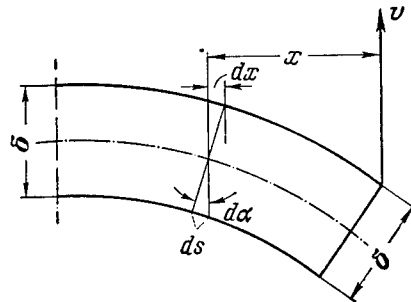

Fig. 28.

We have, approximately

$$\epsilon dx = \frac{\delta}{2} \cdot d\alpha;$$

whence the differential of angular rotation of the plate

$$278. \quad d\alpha = \frac{\epsilon dx}{\frac{\delta}{2}} = \frac{2}{\delta} dx.$$

The differential of the deflection l of the end of the plate is

$$279. \quad dl = x \cdot d\alpha = \frac{2\epsilon}{\delta} \cdot x dx,$$

or, in accordance with (277) and eliminating ϵ :

$$280. \quad d\delta = \frac{12Vx^2}{\delta^3 E} \cdot dx.$$

On integrating this expression, we have

$$281. \quad \delta = \frac{4Vx^3}{\delta^3 E}.$$

Putting $x = L$ and given, in accordance with (247), that

$$V = H \cdot \frac{z}{L}, \text{ we obtain}$$

$$282. \quad \delta = \frac{4HzL^2}{\delta^3 E}.$$

This equation shows the deflection of the end of the plate to the point z as a function of the longitudinal tensile force. In equation (277) let us put $x = L$ and

$$283. \quad \epsilon = \frac{K_e}{E};$$

whereupon we obtain

$$284. \quad V = \frac{K_e \delta^2}{6L},$$

whence, by means of (274), we find

$$285. \quad H = \frac{K_e \cdot \delta^2}{6z},$$

or

$$286. \quad z = \frac{K_e \delta^2}{6H}.$$

Since the greatest depth of the corrugation is h ,

287. $l = h - z$ (Fig. 27); accordingly, by means of equation (282), we obtain

$$288. \quad H = \frac{E \delta^3}{4 L^2} \left(\frac{h - z}{z} \right).$$

From this equation and from equation (285), eliminating H , we have

$$289. \quad \frac{h - z}{L} = \left(1 - \frac{z}{h} \right) \cdot \frac{h}{L} = \frac{2LK_e}{3\delta E};$$

clearly, the first and second parts of this expression are identical. It gives the relative deflection $\frac{h-z}{L}$ of the plate as a function of its dimensions and the properties of the material of which it is made.

290. From the ratios h/L and z/h we can also find, by purely geometrical means, the longitudinal elongation of the corrugations. A normal cross section through the plate or corrugation has the form (Fig. 27) of a curve which, in view of its gentle slope, may be regarded as the inclined straight line S , so that, according to Fig. 27, we have approximately

$$291. \quad S^2 = L^2 + z^2 \quad \text{and} \quad S^2 = L_0^2 + h^2,$$

and hence

$$292. \quad \frac{S}{L} = \sqrt{1 + \left(\frac{z}{L}\right)^2} \quad \text{and} \quad \frac{S}{L_0} = \sqrt{1 + \left(\frac{h}{L_0}\right)^2},$$

but since the ratios z/L and h/L_0 constitute a small fraction of unity,

$$293. \quad \frac{S}{L} = 1 + \frac{z^2}{2L^2} \quad \text{and} \quad \frac{S}{L_0} = 1 + \frac{h^2}{2L_0^2};$$

subtracting one from both sides, we obtain

$$294. \quad \frac{S - L}{L} = \frac{z^2}{2L^2} \text{ and } \frac{S - h_0}{h_0} = \frac{h^2}{2L_0^2};$$

and since $\frac{L_0}{L} \approx 1$, we may write

$$\frac{S - L}{L_0} = \frac{z^2}{2L_0^2} \text{ and } \frac{S - L}{L_0} = \frac{h^2}{2L_0^2},$$

We have determined the relative elongation of the corrugated surface independently of its elasticity, when it passes from the corrugated form with deflection z to the perfectly flattened state, something which cannot occur in actual practice, for that would require an infinite longitudinal force which would have the effect of destroying the surface rather than stretching it.

The elongation corresponding to a deflection h is $h^2/2L_0^2$;

consequently, the elongation corresponding to a deflection from h to z will be:

$$295. \quad \frac{L - L_0}{L_0} = \frac{h^2 - z^2}{2L_0^2},$$

or, dividing the numerator and denominator on the righthand side by h^2 :

$$296. \quad \frac{L - L_0}{L_0} = \frac{1}{2} \left(1 - \frac{z^2}{h^2} \right) \cdot \frac{h^2}{L_0^2} .$$

Note that the true elongation is slightly greater than that given by the formula.

Minimum Dimensions of Envelope. Application to Various Shapes

297. Now we have all the data needed to find the minimum dimensions of the metal envelope from the point of view of its structural integrity and the elastic stretching of its corrugated surface on passing from the folded to the inflated form.

For any aerostat, as we have seen, the relative elongation of the panels is expressed approximately by the formula (253):

$$\frac{A_1}{dx} = \frac{-\pi^2}{8} \cdot y \cdot \frac{d^2y}{dx^2} .$$

This is the maximum elongation along the center-line of the gas envelope (Fig. 20); if this elongation is elastic, then the elongation of the other panels forming part of the same strip above and below the center-line (Fig. 20) will certainly be elastic; actually, the number of corrugations in each panel of a given strip is constant, so that the wavelength is constant for each strip; the depth of the corrugation gradually diminishes, tending to zero at the ends of the strip. Naturally, then, if the stretching of the steep corrugations at the center-line is elastic, that of the gentler corrugations will be even more so. It is for this reason that I use only the steepest corrugation at the center-line in my calculations.

The stretching (Fig. 21) is inevitable in view of the geometrical properties of the folding surface. But, on the other hand, the elongation of the corrugated surface as a function of the slope h/L of the corrugations and the bending z/h is determined by equation

(296). Therefore, eliminating A/dx or, which amounts to the same thing, $\frac{L - L_0}{L}$, from equations (253) and (296), we find

$$298*. \quad \frac{-\pi^2}{4} \cdot y \cdot \frac{d^2 x}{dx^2} = \left(1 - \frac{z^2}{h^2} \right) \cdot \frac{h^2}{L_0^2}.$$

Now from this equation and (289), on eliminating h/L , we get

$$299. \quad L^2 = \frac{-9}{16} \pi^2 \cdot y \cdot \frac{d^2 y}{dx^2} \cdot \frac{\delta^2 \cdot E^2}{k_e^2} \cdot \frac{\left(1 - \frac{z}{h} \right)}{\left(1 + \frac{z}{h} \right)}.$$

Hence, using (289) and eliminating L , we find

$$300. \quad h = \frac{-3}{8} \cdot \pi^2 y \cdot \frac{d^2 y}{dx^2} \cdot \frac{\delta E}{\left(1 + \frac{z}{h} \right) \cdot K_e}.$$

Here we find the depth h of the corrugation as a function of the geometrical properties of the general shape of the aerostat, the form of the corrugated surface and its elasticity; however, we have

taken into account the transverse bending of the corrugated surface, when the gas envelope is inflated. For this we have formula (271), which we now transform thus:

$$301. \quad h = y \cdot \frac{K_e}{nE};$$

where n is a safety factor indicating how many times the depth of the corrugations should, for safety's sake, be assumed less than the critical depth defined by formula (271).

From the last two equations, on eliminating h , we have

$$302. \quad 1 = \frac{-3}{8} \cdot \pi^2 \cdot \frac{d^2 y}{dx^2} \cdot \frac{n\delta E^2}{K_e^2 \left(1 + \frac{z}{h}\right)}.$$

303. For example, for a parabolic aerostat we find

$$\frac{d^2 y}{dx^2} = \frac{-2y_1}{x_1^2}.$$

Accordingly, on eliminating the second-order derivative from equation (302), we have

$$y_1 = \pi^2 \left(\frac{y_1}{x_1}\right)^2 \cdot \frac{n\delta E^2}{K_e^2 \left(1 + \frac{z}{h}\right)}.$$

304. Clearly then, the radius y_1 of the greatest cross section through the envelope is directly proportional to the thickness δ or strength* of the envelope (with respect to failure of the corrugated surface), and inversely proportional to the square of the limiting elastic strain K_e^2/E^2 .

This radius y_1 is also inversely proportional to the square x_1^2/y_1^2 of the aspect ratio of the envelope and the quantity $1 + z/h$.

305. Clearly, the height $2y_1$ of the envelope may be arbitrarily small if the aspect ratio is sufficiently large; the thickness δ of the envelope and the other variables included in the formula may be either arbitrarily large or arbitrarily small.

306. The dimension $2y_1$ of the envelope may also be as small as desired even with a small aspect ratio x_1/y_1 , provided the envelope thickness is sufficiently small.

307. The limiting elastic strain K_e/E depends on the material selected for the envelope.

Thus (according to Bach), for wrought iron or cast iron we may assume that on the average $K_e/E = 1/1000$.

For untempered drawn iron (e.g., for wire) $K_e/E = 1/500$; for tempered drawn iron $K_e/E = 1/1000$, i.e., the same as for wrought iron; for the best-quality tempered steel $K_e/E \leq 1/250$; for rolled copper or bronze sheet, on the average $K_e/E \approx 1/3000$.

*More accurately, the elastic safety factor.

But there exists a grade of forged bronze for which

$$\frac{1}{400} \leq \frac{\sigma}{E} \leq \frac{1}{300} .$$

308. In equation (303), we may put

$$\frac{y_1}{x_1} = \frac{1}{7} ; \delta = \frac{1}{7} \text{ mm}; \quad n = 1; \quad \frac{K_e}{E} = \frac{1}{500} ; \quad \frac{z}{h} = \frac{1}{3} ;$$

so that $y_1 = 4$, i.e., the vertical diameter of the elastic folding metal envelope will be less than 8 meters. But if we were to use material twice as thick, the height of the envelope would be twice as great, i.e., 16 meters. Now if all the data of (308) were left the same, but the height $2y_1$ of the envelope increased, say by 3 times, then n would be increased by the same number of times.

309. We find the depth h of the corrugations from the equation (271):

$$h = \frac{y_1 \sigma}{nE} .$$

Hence, given the data of (308), we find $h = 8$ mm, i.e., $2h = 16$ mm.

From this equation and (289), eliminating h , we find the wavelength λ :

$$L = \sqrt{\frac{3}{2} \cdot \frac{y}{n} \left(1 - \frac{z}{h}\right) \delta};$$

310. For the data of (308) and $y = 4$ meters, we find $L = 23.9$ mm, or $2L \approx 48$ mm; the ratio $L/h = 3$. At other cross sections through the same envelope L and h will be smaller.

311. We must bear in mind that the depth h computed from these formulas is perfectly safe; actually, as the walls of the envelope stretch and the corrugations straighten out, their true depth, like the danger of rupture or wrinkling, will steadily decrease. Moreover, the true depth decreases the greater the distance from the center-line, as the longitudinal girders are approached (Fig. 1).

312. If we took thicker and less elastic material for our envelope, for instance, soft annealed iron $2/7$ mm thick, the dimensions of the elastic bag would be far greater; thus, for a parabolic aerostat, $y = 32$ meters or $2y = 64$ meters, in accordance with formula (303).

313. But this does not imply that it is impossible to construct small aerostats using material of low elasticity ($K/E=1/1000$).

In fact, as the aerostat is inflated the corrugations may at first stretch inelastically. But for volume changes once the envelope is full of gas, even moderate elasticity will be entirely sufficient.

314. In this case we make use of equation (298), from which we find geometrically, independently of the elasticity of the material:

$$\frac{h}{L_0} = \frac{\pi}{2} \sqrt{\frac{-d^2y}{da^2} \cdot \frac{y}{1 - \frac{z}{h^2}}}.$$

315. Thus, for a parabolic envelope we have

$$\frac{h}{L_0} = \pi \cdot \frac{y_1}{x_1} \sqrt{\frac{y}{2y_1 \left(1 - \frac{z^2}{h^2}\right)}}.$$

316. Here, h may be determined empirically or by means of formula (271):

$$h = y \cdot \frac{K_e}{nE}.$$

Of course, h will be different for each cross section. Suppose, for example, that we are constructing an envelope with a height, in the inflated state, of 25 meters; further, let us suppose that $n = 1$, $\frac{K_e}{E} = \frac{1}{1000}$ (mild steel), $y_1 = 12^{1/2}$; we then arrive at $h = 12^{1/2}$ mm.

Now, for the central cross section let us substitute in formula (315): $y = y_1$, $\frac{y_1}{x_1} = \frac{1}{7}$, $\frac{z}{h} = \frac{1}{3}$; we then find $\frac{L}{h} = 3.341$.

Thus, the wavelength will be 3 and 1/3 times the depth h . In the same way we compute the greatest depth of the corrugations at other normal cross sections through the envelope.

317. In view of the fact that, in practice, the simplest possible form must be given to the corrugations, without superimposing second-order waves, formula (271) will not always prove useable; the best procedure is to find by experiment the safe maximum radius of curvature for specific corrugated surfaces made of dif-

ferent materials and with corrugations of different size and shape.

318. So far I have applied my general formulas (302) solely to a parabolic aerostat.

For an elliptical envelope

$$y = y_1 \sqrt{1 - \frac{x^2}{x_1^2}}$$

and hence

$$\frac{d^2y}{dx^2} = \frac{-y_1^4}{x_1^2 y^3}.$$

Accordingly, by eliminating the derivative from equation (302), we obtain

$$319. \quad y_1 = \frac{3}{8} \pi \left(\frac{3}{x_1}\right)^2 \left(\frac{y_1}{y}\right)^3 \cdot \frac{n \cdot \delta \cdot E^2}{\left(1 + \frac{z}{h}\right) K_e}.$$

Clearly, the radius of the central cross section y_1 depends on y , i.e., the size of the envelope of an elliptical aerostat is inversely proportional to y^3 , or to the cube of the radius of the smallest cross section of the envelope, at the point where the corrugations end and the smooth conical surface begins.

320. Thus, given the conditions of (308) and assuming $\frac{y_1}{y} = 3$, we arrive at $y_1 = 54$ meters; while if $\frac{y_1}{y} = 2$, $y_1 = 16$ meters.

These dimensions are extremely large. Therefore an elliptical aerostat can not be considered practicable.

In a parabolic aerostat, the folds and corrugations decrease in proportion to the decrease in the radius of the cross section; therefore, if the corrugations bend without difficulty in the middle, they will bend even more readily at the narrow ends of the corrugated surface. In an elliptical aerostat, on the other hand, the gaps or corrugations increase rapidly toward the edges, so that safe bending at the middle of the envelope does not insure safe bending at the narrow ends, but quite the contrary. As a consequence, the calculations (319) are made for the end rather than the middle cross section.

321. For a surface of revolution, the central longitudinal section of which is expressed by the formula

$$y = y_1 \left(1 - \frac{x^2}{x_1^2}\right)^{3/4},$$

$$\frac{d^2y}{dx^2} = \frac{-3}{4} \left(\frac{y_1^2}{x_1^2}\right) \cdot \frac{2 - \frac{x^2}{x_1^2}}{y \sqrt{1 - \frac{x^2}{x_1^2}}}.$$

Accordingly, eliminating the second derivative from equation (302), we obtain

$$322. \quad y_1 = \frac{9}{32} \pi^2 \left(\frac{y_1}{x_1}\right)^2 \left(\frac{y_1}{y}\right) \cdot \frac{2 - \frac{x^2}{x_1^2}}{\sqrt{1 - \frac{x^2}{x_1^2}}} \cdot \frac{n\delta E^2}{\left(1 + \frac{z}{h}\right) K_e}.$$

Clearly, from the formula, the radius y_1 of the central cross section increases as the radius y of the smooth conical surfaces at the ends of the aerostat decreases. But this increase is not so rapid as in the case of an elliptical aerostat.

323. Assuming the conditions of (308) and assuming further that $\frac{x}{x_1} = 3/4$, we find from equations (321) and (322)

$$\frac{y_1}{y} = 1.86 \text{ and } y_1 = 6.08 \text{ m.}$$

This aerostat would not be very large, even if the smooth cones were smaller.

324. For an elongated cosinusoid (260):

$$y = y_1 \cos\left(\frac{\pi \cdot x}{2x_1}\right) \text{ and } \frac{d^2y}{dx^2} = \frac{-\pi^2}{4} \cdot \frac{y}{x_1^2}.$$

Consequently, from (302) we have:

$$325. \quad y_1 = \frac{3 \cdot \pi^4}{32} \cdot \left(\frac{y_1}{x_1}\right)^2 \cdot \frac{y}{y_1} \cdot \frac{n \cdot \delta \cdot E^2}{\left(1 + \frac{z}{h}\right) \cdot K_e}.$$

Clearly, the dimension y_1 is proportional to y . The calcula-

tions must be done putting $y = y_1$. We then obtain

$$326. \quad y_1 = \frac{3 \cdot \pi^4}{32} \cdot \left(\frac{y_1}{x_1}\right)^2 \cdot \frac{n \cdot \delta \cdot E^2}{\left(1 + \frac{z}{h}\right) \cdot K_e^2}.$$

Compared with a parabolic aerostat under identical conditions, the dimension y_1 for this balloon will be $\left(\frac{\pi^2}{8}\right)$, or 1.2337, times greater, i.e., y will be 4.93 meters, or about 5 meters.

We should not forget formulas (271) and (310) in connection with the wavelength and depth of the corrugations. Thus, we can derive the slope h/L from these two equations:

$$327. \quad \frac{h}{L} = \frac{K_e}{E} \sqrt{\frac{2y}{3n\delta \left(1 + \frac{z}{h}\right)}}.$$

328. The last equation shows that the slope h/L of the corrugations increases as \sqrt{y} as the cross section or the distance to the ends of the elongated envelope decreases.

329. If the thickness δ diminishes toward the ends of the envelope in proportion to the decrease in the dimension y of the cross section, so that the ratio y/δ remains constant, then, as will be clear from the last formula, the slope along any given line running from end to end of the envelope will likewise remain constant. Both the depth and the wavelength of the corrugations will fall off

toward the ends of the envelope (271).

330. If we disregard the properties of the material and center our attention on the geometrical conditions, we must not forget formula (314) in determining the slope. Thus, for a parabolic aerostat we have formula (315), but for an elliptical aerostat, on the basis of (314) and (315) we compute

$$331. \quad \frac{h}{L_0} = \frac{\pi^2 y_1^2}{2yx_1 \sqrt{1 - \frac{z^2}{x^2}}};$$

from which it is clear that the slope h/L_0 for an elliptical gas envelope will be inversely proportional to the dimension y of the cross section, whereas in the case of a parabolic envelope it is directly proportional to \sqrt{y} (cf. formula (315)).

Clearly then, as we also see from the general formula (314), the law of the slope h/L_0 depends on the shape of the elongated envelope, if the stretching of the corrugated surface is only partially elastic. Otherwise, the curvature h/L will be independent of the shape, and will depend solely on the dimension y of the cross section [cf. equation (327)].

Stretching of the Corrugated Surface in General

332. In general, the formulas in this chapter will also prove useful for determining the elastic elongation of the corrugated

surface and the force producing that elongation.

Thus, from formula (289), denoting the slope h/L of the corrugations as k , we obtain

$$333. \quad \frac{z}{h} = 1 - \frac{2LK_e}{3k\delta E}.$$

Now, from (296), by eliminating z/h , we find

$$334. \quad \frac{L - L_0}{L_0} = \frac{2LK_e}{3\delta E} \cdot \left(k - \frac{L\sigma}{3\delta E} \right).$$

335. Clearly, the elastic elongation of the corrugated plane in general, irrespective of the type of aerostat, will increase with increase in the slope h/L of the corrugations.

This formula may be rewritten:

$$\frac{L - L_0}{L_0} = \frac{k^2}{2} \left[1 - \left(1 - \frac{2LK_e}{3\delta} \right)^2 \right].$$

It is now obvious that the relative elastic and the maximum elongation is inversely proportional to the thickness δ of the surface, and directly proportional to the wavelength L and to the limiting strain K_e/E of the material. When the ratio L/δ of wave-

length to thickness remains constant, the relative elongation remains constant.

336. For example, when $L = 20$ mm, $\delta = 1/7$ mm, $\frac{K_e}{E} = 1/500$, $k = 1/3$, we find from (334) that $\frac{L = L_0}{L} = 0.4448$, i.e., about $1/22$.

337. We must also find the tensile force H acting on the corrugated surface; equation (288) will serve this purpose. On eliminating the ratio h/z from that equation by means of formula (333), we get

$$H_{\max} = \frac{\delta \left(\frac{\delta}{L} \right) \cdot E}{K_e k \left(\frac{E}{\sigma} \right) - \frac{4}{\left(\frac{\delta}{L} \right)}}.$$

Clearly, the tensile force will be proportional to the modulus of elasticity E and the thickness of the material. But it will be inversely proportional to the ratio $\frac{E}{K_e}$ and the slope of the corrugations. The formula gives the maximum tensile force when the elastic limit K_e is reached.

338. Suppose that, for instance, $\delta = 1/7$ mm = $1/70$ cm, $L = 20$ mm = 2 cm, $\frac{E}{K_e} = 500$, $k = 1/3$, $E = 2 \cdot 10^6$ kg/cm².

Then, in accordance with the last formula, we find as the limiting elastic tensile force on a corrugated surface 1 cm wide: $H = 0.46$ kg.

339. We are also in a position to demonstrate the relationship between the tensile force H and the corresponding relative elongation ϵ_r of the corrugated surface. We find from (296), writing ϵ_r instead of $\frac{L - L_0}{L_0}$ for the sake of brevity:

$$\frac{h}{z} = \frac{1}{\sqrt{1 - 2 \left(\frac{L_0}{h}\right)^2 \cdot \epsilon_\Gamma}}.$$

Now, eliminating h/z from (288), we find

$$H = \frac{\delta^3 E}{4 \cdot L^2} \cdot \left[\frac{1}{\sqrt{1 - 2 \left(\frac{L_0}{h}\right)^2 \epsilon_\Gamma}} - 1 \right].$$

This shows only that an increase in the elongation ϵ_Γ means a proportionate increase in the force H required to produce this elongation.

340. But this last formula can be simplified. In fact, if the corrugations are sufficiently steep, the expression $2 \left(\frac{L_0}{h}\right)^2 \epsilon_\Gamma$ will represent a small fraction, so that we may write

$$\sqrt{1 - 2 \left(\frac{L_0}{h}\right)^2 \epsilon_\Gamma} = 1 - \left(\frac{L_0}{h}\right)^2 \epsilon_\Gamma.$$

Simplifying the formula in this way, we find

$$H = \frac{\delta^3 E}{4L^2} \cdot \frac{\left(\frac{L_0}{h}\right)^2 \epsilon_{\Gamma}}{1 - \left(\frac{L_0}{h}\right)^2 \epsilon_{\Gamma}}$$

or, again approximately and on the same basis as before, discarding the comparatively insignificant negative term in the denominator, we have

$$H = \frac{\delta^3 E}{4h^2} \epsilon_{\Gamma}$$

341. Accordingly, the tensile force may be assumed to be approximately proportional to the elongation ϵ_{Γ} of the corrugated surface. Let us not forget that this last formula is used when ϵ_{Γ} is very small compared with the limiting elongation. This means that the tensile force will be proportional to ϵ_{Γ} only at the very beginning, whereas later it will increase at a much faster rate than ϵ_{Γ} .

Thus, for the limiting elongation, putting $E = 2 \cdot 10^6$ kg/cm², $L = 2$ cm, $k = 1/3$, and $h = 2/3$, $\epsilon_{\Gamma} = 1/22$, $\delta = 1.70$ cm, we find from the simplified formula $H = 0.15$ kg, but in actual fact

$$H = 0.49 \text{ kg [cf. (338)]}.$$

Consequently, when ϵ_{Γ} is close to the elastic limit, it is

necessary to use formula (339).

Application of the Formulas to Straight Corrugations.
Various Systems of Folding and Convoluted
Metal Envelopes

342. It is clear from this chapter and from Chapter V that in the folded state the corrugated surface of the aerostat envelope may take one of two forms: the form of straight corrugations (Chapter V) with crests at right angles to the principal longitudinal axis of the envelope (Fig. 5), or the form of curved corrugations (Fig. 20). The calculations in Chapter VII relate to the latter variant, the second form of the metal envelope.

The construction of an envelope of the first or straight-corrugation type is incomparably simpler and consequently is more to be recommended, particularly large aerostats, though this type of envelope may also have certain disadvantages.

The formulas in Chapter VII are equally applicable to the construction of a folding metal envelope with straight corrugations (Fig. 5), except that some of them then prove superfluous, notably (233), (234), and (236). But these formulas, of course, were necessary to the derivation of other equations, without the aid of which it would have been impossible to investigate the conditions and prerequisites for constructing the metal envelope of an aerostat.

My formulas are also applicable to the construction of a dirigible with a soft envelope. Assuming, for instance, the simplest possible design (Fig. 5) for an elongated envelope, we can use equations (240) and (241) to determine the size of the folds between the strips of material (Fig. 2). Having sewn up this envelope, with the proper folds [formula (253) may prove useful in this respect], we find that the folds smooth out as the balloon is inflated and the surface of revolution begins to take shape.

343. But we must not lose sight of the fact that these formulas still require correction, since the cross section of the envelope is not a circle, as we assumed, but some other more complicated curve (Fig. 1 and Fig. 15), the shape of which will depend in part on the magnitude of the longitudinal tensile force acting on the corrugated surface; only when this force is completely absent or when it is ideally uniform will the shape be the same as that determined in Chapter VI.

344. The metal envelope of the aerostat could be made of several flat strips (Fig. 2), without corrugations, so as to consist of say ten or even fewer parts. But these parts must be connected by soft folds (rubberized fabric or the like), which smooth out when the elongated bag is filled with gas and its cross section more or less approximates a circle or some other well-defined shape. The smooth metal surfaces may overlap each other, thereby protecting the folds.

In some instances, for example in testing models and in early experiments, this type of envelope may find useful applications. The aerostat will then be somewhat reminiscent of an insect covered with rings which partially overlap each other. Here my formulas will be required to calculate the shape and size of the soft folds*.

345. Experiments on models reveal that a streamlined envelope can even be based on two smooth surfaces of double curvature joined in the middle by a single metal-shielded fold. The aerostat will have approximately the same shape and the same properties as one made with a corrugated surface.

346. Finally, my calculations and experiments on models also indicate the possibility of designing a smooth aerostat entirely free of folds. But the shape of the cross section will depart slightly from that arrived at in Chapter VI and depicted in Figures 1, 13, 15. Such aerostats are feasible given a slight change in volume (about one tenth).

Envelopes in the last two categories have the further disadvantage, in addition to those noted earlier, that they cannot be folded flat, so that they will present great difficulties in connection with the processes of fabrication and inflation.

*This aerostat was approved by Prof. Zhukovskiy [Joukowski] and by foreign specialists and patented internationally but I was the first to reject it as being imperfect.

VIII. THE PRINCIPAL LONGITUDINAL CROSS SECTION OF THE ENVELOPE AND ITS PROPERTIES. SURFACE AND VOLUME OF THE ENVELOPE. MOMENT OF THE WEIGHT OF THE ENVELOPE AND MOMENT OF THE LIFTING FORCE OF THE GAS.

Choice of Longitudinal Section of Envelope

347. The shape of the cross section of the aerostat is largely determined by certain natural conditions: gas pressure, gravity, the longitudinal elasticity of the corrugated surface. Even though we can artificially influence these conditions to some extent, on the whole the cross section of the envelope will retain its characteristic shape (Figs. 1, 15).

By contrast, the cross section of a ship depends more on the designer. It is usually defined by a curve somewhere between a semi-circle and the circumscribed rectangle, and is expressed as the equation of the parabola:

$$348. \quad y = y_1 \left(1 - \frac{x^m}{x_1^m} \right).$$

Here x_1 is the horizontal half-width of the cross section, and y_1 its height (Fig. 29).

The larger the value of m , the more closely the cross section will approximate to a rectangle; when $m = 1$ the cross section becomes a triangle. Clearly, $m > 1$. Moreover, m must be a fairly large number in order to make the more or less rounded cross section closer to a rectangle, minimize rolling, and raise the metacenter as high as possible. The stability of the ship demands this shape, since the stability will be the greater the higher the metacenter and the lower the center of gravity.

349. In our case, the lateral rolling (Fig. 1) is reduced by the enormous indented surface at the top of the envelope and by the

gondola -- which acts as a keel. In addition, the low position of the center of gravity and the high position of the metacenter give the transverse section of the envelope excellent stability.

350. But the longitudinal section of the envelope, like a ship's hull, may be given a variety of shapes: in a ship the central longitudinal section may be defined approximately by the same parabolic curve (348) as the transverse section, except, of course, that the ratio x_1/y_1 will be much larger than in the case of the transverse section, where it will usually be only slightly greater than unity, whereas in the case of the longitudinal section the ratio may be 10 or more.

The bow of a ship is sometimes made more convex and steeper than the stem, in the manner of fishes or birds, the object being to minimize the resistance of the water. As for m , it assumes a wide range of values in different types of ships; in both transverse and longitudinal sections the greater m the steeper the slope of the curve and the greater the so-called fullness of the section and the amount of water displaced.

Clearly, a decrease in m results in a certain decrease in the drag of the hull and contributes to a higher speed through the water.

351. Theoretical attempts to determine the form offering least resistance, and even experiments designed for that purpose, have failed to yield useful results, and the principal laws which have so far governed the design of ships have not been subtle and sophisticated, but simply the traditional parabola and its equation for both the longitudinal and transverse sections.

352. The shape of the longitudinal section of an aerostat envelope is limited not only by the minimum resistance requirement but also by convenience in construction and the requirement of adequate longitudinal stability.

In order to achieve variable volume and plane construction, the aerostat must end in conical surfaces. Accordingly, rounded ends, as in the case of an ellipsoid of revolution, are impractical from this point of view. Moreover, we have seen (Chapter VII) that certain shapes require a large metal envelope, if the volume is to be safely varied.

This likewise places restrictions on the choice of envelope shape.

But if we are not concerned about the size of the aerostat, we are, of course, free to resort to other shapes, even to an ellipsoid, except that the rounded ends must be replaced by conical

surfaces tangent to the ellipsoid.

353. The traditional parabola used for ships thus deserves our attention in relation both to the minimization of resistance and to construction. Aside from my numerous experiments on air resistance*, extending over many years, the very fact of the use of the parabola in the design of ships is a compelling argument in support of its advantages with respect to drag.

354. Let us now turn our attention to the question of design. I have already given the equation of a parabola:

$$y = y_1 \left(1 - \frac{x^m}{x_1^m} \right).$$

Hence

$$\frac{d^2y}{dx^2} = -m(m-1) \cdot \left(\frac{y_1 x^{m-2}}{x_1^m} \right).$$

Consequently, on the basis of equation (302), we find -

$$355. \quad y_1 = \frac{3}{8} \pi^2 (m-1) m \left(\frac{y_1}{x_1} \right)^2 \cdot \frac{n\delta E^2}{K_e^2 \left(1 + \frac{z}{h} \right)} \left(\frac{x}{x_1} \right)^{m-2}.$$

*Cf. my articles "Air resistance," "Horizontal motion of a dirigible," "Air pressure," and other works on drag.

We have now found the radius y_1 of the center cross section of a metal envelope folding elastically into a plane. There are three possible cases:

$$m = 2, m > 2 \text{ and } m < 2.$$

356. In the first case the equation of the parabola will be:

$$y = y_1 \left(1 - \frac{x^2}{x_1^2} \right).$$

This is an ordinary parabola, i.e., a conic section. We shall term its slope the average slope.

In this case, the factor $\left(\frac{x}{x_1}\right)^{m-2}$ in equation (355) will be unity. Consequently, the dimension y_1 of the aerostat will not depend on x , or on a most dangerous cross section. All the cross sections will be equally dangerous or equally safe.

357. In the second case the curve will be steeper, i.e., more air will be displaced, the displacement being the greater the higher the value of m . We can see from equation (355) that y_1 will depend on x or on the cross sections where the smooth cones begin. The smaller the latter and the larger the ratio x/x_1 the greater will be the vertical dimension y_1 of the envelope. But we can not make the smooth cones very large. The ratio x/x_1 will therefore be

roughly $9/10$ to $4/5$, but not less. It is to this range of values of x/x_1 that y_1 must also correspond.

Consequently, in comparison to a simple conical parabola, the dimension y_1 of the envelope will be $\left[\frac{m(m-1)}{2 \cdot 1} \left(\frac{x}{x_1} \right)^{m-2} \right]$ or $\left[\frac{m(m-1)}{2 \cdot 1} \left(\frac{x}{x_1} \right)^p \right]$ times greater, where p is any positive number equal to $(m-2)$.

358. If, for example, $m = 3$ while $\frac{x}{x_1} = 4/5$, then

$$\frac{m(m-1)}{2 \cdot 1} \left(\frac{x}{x_1} \right)^{m-2} = 2.4,$$

i.e., y_1 will be 2.4 times greater than in the case of a conic section.

359. In the third case, when $m < 2$, y_1 will also depend on the ratio $\left(\frac{x}{x_1} \right)^{m-2}$.

We may then write

$$\left(\frac{x}{x_1} \right)^{m-2} = \left(\frac{x}{x_1} \right)^{-p} = \left(\frac{x}{x_1} \right)^{+p},$$

where p is likewise any positive number less than two.

Clearly, the dimension y_1 will vary inversely with x ; we must therefore compute y_1 for the minimum x .

But when $x = 0$, according to equation (355), y_1 is infinity, so that in this case an aerostat will be impossible.

360. The reason why it is impossible at once becomes evident when we turn our attention to the radius of curvature ρ of the parabola. It is:

$$361. \quad \rho = \frac{-1}{m(m-1)} \left(1 + m^2 \frac{y_1^2 x^{2m-2}}{x_1^{2m}} \right) \sqrt{\frac{x_1^{2m}}{y_1^2 x^{2m-4}} + m^2 x^2}.$$

If we assume that m is some number at most slightly less than two, we have $m = 2 - p$, where p is any positive number less than two. The radius of curvature ρ will then be:

$$362. \quad \rho = \frac{-1}{m(m-1)} \left(1 + m^2 \frac{y_1^2 x^{2-2p}}{x_1^{2m}} \right) \sqrt{\frac{x_1^{2m} x^{2p}}{y_1^2} + m^2 x^2}.$$

When $x = 0$, clearly, the radius of curvature will also vanish, no matter how small p .

Here the infinitely large curvature at the center cross section of the metal envelope prevents its construction, even though at a glance the curve appears to be perfectly smooth, particularly when m is only slightly less than two. But the further this exponent m departs from two and the more closely it approaches unity, the more noticeable will become the rounded angle in the center of the envelope, and, in the limit when $m = 1$, the envelope will consist of two conical

surfaces joined at the base. Thus, there is no point of even considering a parabolic envelope if $m < 2$.

363. We arrive at exactly the same result if we eliminate the abscissa x from equation (355) by means of equation (348) for a parabolic curve.

We obtain

$$\frac{x}{x_1} = m \sqrt{1 - \frac{y}{y_1}},$$

and consequently:

$$364. \quad y_1 = \frac{3}{8} \pi^2 (m - 1)^m \left(\frac{y_1}{x_1}\right)^2 \cdot \frac{n\delta E^2}{K_e^2 \left(1 + \frac{z}{h}\right)} \cdot \left(1 - \frac{y}{y_1}\right)^{\frac{m-1}{m}}.$$

365. The ratio of the dimensions of this parabolic envelope and a simple envelope (conic section) is

$$\frac{m(m - 1)}{1 \cdot 2} \left(1 - \frac{y}{y_1}\right)^{\frac{m-2}{m}}.$$

Clearly, then, the smaller y , or the radius of the base of the base of the smooth cone, the greater will be the ratio of the dimensions of the envelopes; in the limit it will attain the value

$\frac{m(m - 1)}{1 \cdot 2}$; for example, in the case of a cubic parabola, we get three.

But the greater y , the smaller this ratio becomes, and when the radius y of the smooth cone becomes equal to the dimension y_1 of the

center cross section, i.e., when the dimension of the parabolic envelope becomes infinitesimally small, it vanishes. This will become clear from an inspection of formula (361) for the radius of curvature, which goes to infinity at the center cross section where $x = 0$. Here an element of the surface is cylindrical.

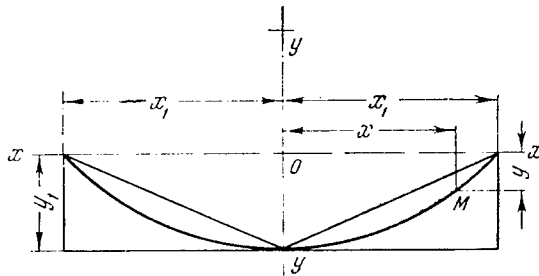

Fig. 29

From the above we can derive the following summary based on a parabolic curve: a) the curve varies between a triangle and a rectangle (Fig. 29); b) construction of the envelope will be possible only if m is equal to or greater than two; c) the greater the exponent m , the greater the dimensions of the folding metal envelope; d) the smallest dimensions of the envelope will correspond to $m = 2$, i.e., to a conic section; e) the greater the value of m , the steeper will be the slope of the curve and the more closely the curve will approximate to a rectangle (Fig. 29); f) in the case of a conic section, when $m = 2$, the radius of curvature (361) will vary extremely little, increasing imperceptibly from the middle of the curve toward the extremities, as is clear from (361) on substituting $m = 2$. We then obtain

$$366. \quad \rho = \frac{1}{2} \left(1 + 4 \cdot \frac{y_1^2 x^2}{x_1^4} \right) \sqrt{\frac{x_1^4}{y_1^2} + 4x^2}.$$

Clearly, as x increases, i.e., toward the ends of the aerostat, the radius of curvature increases. The minimum lies at $x = 0$, and the maximum at $x = x_1$.

367. Consequently, the maximum radius of curvature

$$\rho_{\max} = \left(\frac{x_1^2}{2y_1} + 2y_1 \right) \sqrt{1 + \frac{4y_1^2}{x_1^2}},$$

and the minimum radius of curvature

$$\rho_{\min} = \frac{x_1^2}{2y_1}.$$

368. The ratio will be:

$$\frac{\rho_{\max}}{\rho_{\min}} = \left(1 + \frac{4y_1^2}{x_1^2} \right) \sqrt{1 + \frac{4y_1^2}{x_1^2}}.$$

For example, if the aspect ratio of the aerostat $\frac{x_1}{y_1} = 6$, the ratio of the radii will be 1.17.

This means that the radius of curvature will increase only at a very slow rate in the direction of the ends of the envelope, i.e., the curve will approximate an arc of a circle. The greater the

aspect ratio $\frac{x_1}{y_1}$, the closer the approximation will be.

369. With respect to construction, we see that the following curves are feasible; a parabola if the exponent $m \geq 2$; an ellipse with conical tips; a curve intermediate between these two, an elongated cosinusoid.

Of course, a multiplicity of other curves is also possible.

With respect to drag my experiments failed to reveal any great difference even between such surfaces as an ellipsoid and a surface of revolution whose generatrix is an arc of a circle. The drag, moreover, also depends on the velocity. Thus, when the velocity is low, rounded ends and a steeper forward section (nose section) are advantageous. At higher velocities, these features would be of little value. I shall merely stress that longitudinal sections through the envelope should not have angles except at the extremities, and that the curves should be smooth, like an arc of a circle or a parabola.

370. Assuming that the metal envelope has the shape of a surface of revolution, I shall now compute: the radius of curvature, the arc length of the longitudinal cross section, the cross-sectional areas, the surface area, the volume, the moment of the weight of the envelope, and the moment of the lift force exerted by the gas.

General Formulas

371. For this purpose I shall make use of the following general formulas: for the radius of curvature

$$\rho = \frac{\left(\frac{ds}{dx}\right)^3}{\frac{d^2y}{dx^2}}.$$

372. For the (exact) length of the arc:

$$ds = \sqrt{1 + \left(\frac{dy}{dx}\right)^2} \cdot dx.$$

373. For the (exact) surface area:

$$F = 2\pi \int y ds,$$

or approximately, if the envelope is elongated:

$$F = 2\pi \int y dx.$$

374. By expanding ds in series, we obtain more accurate formulas for the length of the arc and the surface area:

$$\frac{ds}{dx} = \sqrt{1 + \left(\frac{dy}{dx}\right)^2} = 1 + \frac{1}{2} \left(\frac{dy}{dx}\right)^2 - \frac{1}{8} \left(\frac{dy}{dx}\right)^4 + \frac{1}{16} \left(\frac{dy}{dx}\right)^6 - \frac{5}{128} \left(\frac{dy}{dx}\right)^8 + \dots$$

For example, if we limit ourselves to three terms for the arc s and two for the surface area, we have

$$375. \quad s = \int \left\{ 1 + \frac{1}{2} \left(\frac{dy}{dx}\right)^2 - \frac{1}{8} \left(\frac{dy}{dx}\right)^4 \right\} dx,$$

$$376. \quad F = 2\pi \int y \left\{ 1 + \frac{1}{2} \left(\frac{dy}{dx}\right)^2 \right\} dx.$$

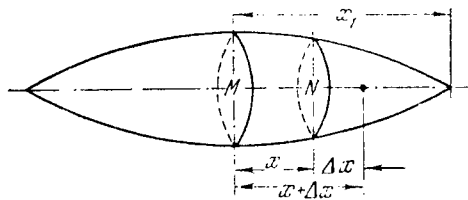

Fig. 30

For the volume of a body of revolution we have (exactly):

$$377. \quad U = \pi \int y^2 dx.$$

The area of the longitudinal section is (exactly):

$$378. \quad F_d = 2 \int y dx,$$

i.e., approximately π times less than the surface of revolution (373).

379. By the moment of the envelope relative to some plane M I mean the product of the weight of an element of the envelope and its distance x from that plane (Fig. 30). The total moment of the envelope may be approximately expressed by the integral

$$M_{\text{env}} = \int 2\pi y q x dx = 2\pi q \int y x dx,$$

where q denotes the weight of the envelope per unit area.

Gravity is one of the destructive forces acting on the aerostat. The total moment of the envelope is a factor tending to cause the collapse of the aerostat. It must be counteracted by the stiffness of the envelope and the four longitudinal girders.

380. By the moment of the lift force relative to some plane M (Fig. 30) I mean the product of the lift force of an element of the gas and its distance from that plane. The total moment of the lift force relative to the plane M may obviously be expressed exactly by the integral

$$M_{\text{gas}} = \int \pi a y^2 x dx = \pi a \int y^2 x dx,$$

where $a = \gamma_{\text{air}} - \gamma_{\text{gas}}$, i.e., is equal to the difference between the density of the air and that of the gas filling the aerostat.

381. The total moment of the lift force is also a resultant, but acts in the opposite direction to the total moment of the envelope. There is a third destructive force that depends on the vapor pressure of the gas; its magnitude varies as a function of the degree of inflation of the envelope. However, I shall discuss this force separately later on.

Application of the General Formulas to a
Parabola (Conic Section)

382. Having derived the necessary formulas, I shall now show how to apply them. Let us begin with the length of the arc of the longitudinal section.

For a parabola the corresponding equation is:

$$y = x_1 \left(1 - \frac{x^2}{x_1^2} \right);$$

and its first derivative:

$$\frac{dy}{dx} = - \frac{2xy_1}{x_1^2}.$$

If we now put $x = x_1$, we obtain, approximately, the tangent of the angle made by the generatrix of the end cone with its axis, namely:

$$\frac{dy}{dx} = \frac{-2y_1}{x_1}.$$

Actually, the more elongated the aerostat, the smaller the angle of the cone. From equation (375), we find on integrating that

$$383. \quad s = x \left(1 + \frac{2}{3} \cdot \frac{x^2 y_1^2}{4 x_1} - \frac{2}{5} \cdot \frac{x^4 y_1^4}{8 x_1} \right).$$

The length of the entire arc from zero to x_1 is found by putting $x = x_1$. Then:

$$384. \quad s_1 = x_1 \left(1 + \frac{2}{3} \cdot \frac{y_1^2}{x_1} - \frac{2}{5} \cdot \frac{y_1^4}{4 x_1} \right).$$

Discarding the last term here, we get the less accurate formula:

$$s_1 = x_1 \left(1 + \frac{2}{3} \cdot \frac{y_1^2}{x_1^2} \right).$$

For the surface area we make use of formula (376). On

integrating, we find:

$$385. \quad F = 2\pi y_1 x \left[1 + \frac{x^2}{x_1^2} \left(\frac{2}{3} \cdot \frac{y_1^2}{x_1^2} - \frac{2}{5} \cdot \frac{x^2 y_1^2}{x_1^4} - \frac{1}{3} \right) \right].$$

The surface area from zero to x_1 is found by putting $x = x_1$:

$$386. \quad F_1 = \frac{4}{3} \pi y_1 x_1 \left(1 + \frac{2}{5} \cdot \frac{y_1^2}{x_1^2} \right),$$

or, less accurately:

$$F_1 = \frac{4}{3} \pi y_1 x_1.$$

From the preceding formulas, we can find the length of the arc from the end x_1 to some intermediate point x , and likewise the surface area; we shall obtain $(s_1 - s)$ and $(F_1 - F)$.

387. We find, approximately:

$$s_1 - s = x \left(1 + \frac{2}{3} \cdot \frac{y_1^2}{x_1^2} \right) - x \left(1 + \frac{2}{3} \cdot \frac{x^2 y_1^2}{x_1^4} \right) =$$

$$= (x_1 - x) + \frac{2}{3} \cdot \frac{y_1^2}{x_1^2} \left(1 - \frac{x^2}{x_1^2}\right)$$

and

$$F_1 - F = 2\pi y_1 \left[\frac{2}{3} x_1 - x \left(1 - \frac{1}{3} \cdot \frac{x^2}{y_1^2}\right) \right]$$

388. The volume is found from formula (377). On integrating, we find exactly:

$$U = \pi \cdot y_1^2 x \left(1 - \frac{2}{3} \cdot \frac{x^2}{x_1^2} + \frac{x^4}{5x_1^4}\right).$$

This is the volume from zero to x .
When $x = x_1$, we have:

$$389. \quad U_1 = \frac{8}{15} \pi y_1^2 x_1.$$

The volume of the end section from x to x_1 is:

$$390. \quad U_1 - U = \pi y_1^2 \left[\frac{8}{15} x_1 - x \left(1 - \frac{2}{3} \cdot \frac{x^2}{x_1^2} + \frac{x^4}{5x_1^4} \right) \right].$$

391. The area of the longitudinal section is given by formula (278). On integrating, we find exactly:

$$F_d = y_1 x \left(1 - \frac{x^2}{3x_1^2} \right).$$

When $x = x_1$, we have

$$392. \quad F_{d1} = \frac{2}{3} y_1 x_1;$$

the difference in areas

$$393. \quad F_{d1} - F_d = y_1 \left[\frac{2}{3} x_1 - x \left(1 - \frac{x^2}{3x_1^2} \right) \right].$$

394. In order to determine the moment of the envelope, we make use of formula (379).

On integrating, we find the moment of the envelope relative to the center cross section M from x to x_1 (Fig. 30):

$$M_{\text{env}} = \frac{\pi}{2} qy_1 x_1^2 \left(1 - \frac{x^2}{x_1^2}\right)^2.$$

Formula (379) is only approximate. The exact formula is:

$$M_{\text{env}} = 2\pi q \int yx \cdot \frac{ds}{dx} \cdot dx.$$

But since ds differs only slightly from dx because of the elongation of the envelope, and no great accuracy is required in determining the moment of the gravitational forces, we may rest content with formula (379).

395. If we put $x = 0$ in equation (394), we obtain the moment from zero to x_1 :

$$M_{\text{env}} = \frac{\pi}{2} \cdot qy_1 x_1^2.$$

396. The moment of the envelope relative to the plane N (Fig. 30) from x to x_1 can also be computed without much trouble. Thus:

$$M_{\text{env}_N} = \frac{\pi}{2} qy_1 x_1^2 \left(1 - \frac{8}{3} \cdot \frac{x}{x_1} + 2 \cdot \frac{x^2}{x_1^2} - \frac{x^4}{3x_1^4}\right).$$

397. In formula (380) we have an exact formula for determining the moment of the lift force exerted by the gas. On integrating, we find the moment of the gas from zero to x :

$$M_{\text{gas}} = \frac{\pi}{6} \cdot ax_1^2 y_1^2 \left[1 - \left(1 - \frac{x^2}{x_1^2} \right)^3 \right] = \frac{\pi}{2} \cdot ax_1^2 y_1^2 \left(1 - \frac{x^2}{x_1^2} + \frac{x^4}{3x_1^4} \right).$$

398. Putting $x = x_1$ in this equation, we obtain the total moment of the gas from zero to x_1 .

$$M_{\text{gas}} = \frac{\pi}{6} \cdot ax_1^2 y_1^2.$$

399. The moment of (the lift force of) the gas relative to the plane N (Fig. 38) from x to x_1 will be:

$$M_{\text{gas}_N} = \pi a y_1^2 \left\{ \frac{1}{6} \cdot x_1^2 \left(1 - \frac{x^2}{x_1^2} \right)^3 - x \left[\frac{8}{15} x_1 - x \left(1 - \frac{2}{3} \cdot \frac{x^2}{x_1^2} + \frac{x^4}{5x_1^4} \right) \right] \right\}.$$

Note that in these formulas "a" stands for the difference between the density of the air and the density of the gas filling the aerostat (the specific lift force of the gas).

Radii of Curvature for Various Curves

400. We have seen how smooth and gentle is the variation of the radius of curvature of the arc of a conic section (368). We have also seen that the radius of curvature of other parabolas varies quite strongly, namely: from zero to some definite value when $m < 2$ and the envelope cannot be successfully constructed, and from infinity to some definite value when $m > 2$ (see formulas (361) to (365)).

401. The equation of an ellipse with respect to its axes is:

$$y = y_1 \sqrt{1 - \frac{x^2}{x_1^2}}.$$

And hence

$$\frac{dy}{dx} = - \frac{xy_1}{x_1^2 \sqrt{1 - \frac{x^2}{x_1^2}}} = - \frac{x}{y} \cdot \frac{y_1^2}{x_1^2} \text{ and } \frac{d^2y}{dx^2} = \frac{-y_1^4}{x_1^2 y^3}.$$

402. From these data and from (371) we now find the radius of curvature:

$$\rho = \frac{\left[x_1^4 \left(1 - \frac{x^2}{x_1^2} \right) + x^2 y^2 \right]^{2/3}}{x_1^2 \cdot y_1 \left[x^2 + x_1^2 \left(1 - \frac{x^2}{x_1^2} \right) \right]} = \frac{y_1^2}{x_1} \left(\frac{x_1^2}{y_1^2} \cdot \frac{y^2}{y_1^2} + \frac{x^2}{x_1^2} \right)^{3/2}.$$

403. For instance, when $x = 0$, $\rho_0 = \frac{x_1}{y_1} \cdot x_1$. But when $x = x_1$,

$$\rho_1 = \frac{y_1}{x_1} \cdot y_1. \text{ Hence, the highest ratio of the radii will be } \frac{\rho_0}{\rho_1} =$$

$$= \left(\frac{x_1}{y_1}\right)^3. \text{ This formula clearly shows how rapidly the radius of}$$

curvature varies in the case of an ellipse. For example, when the aspect ratio of the envelope is 6, i.e., $\frac{x_1}{y_1} = 6$, the greatest radius

will be 216 times larger than the smallest radius, whereas, in the case of a parabola ($m = 2$) the same ratio yields a value only slightly greater than unity (368).

404. In the case of a curve which I shall term intermediate between an ellipse and a parabola:

$$y = y_1 \left(1 - \frac{x^2}{x_1^2}\right)^{3/4}; \quad \frac{dy}{dx} = \frac{-3xy_1}{2x_1^2 \sqrt[4]{1 - \frac{x^2}{x_1^2}}} = -\frac{3}{2} \cdot \frac{xy_1}{x_1^2} \cdot \sqrt[3]{\frac{y_1}{y}};$$

$$\frac{d^2y}{dx^2} = -\frac{3}{4} \cdot \frac{y_1^2}{x_1^2} \cdot \frac{\left(2 - \frac{x^2}{x_1^2}\right)}{y \sqrt[4]{1 - \frac{x^2}{x_1^2}}}.$$

405. And consequently:

$$\rho = \frac{\left[1 + \frac{9}{4} \cdot \frac{x^2 \cdot y_1^2}{x_1^4} \cdot \left(\frac{y_1}{y} \right)^{2/3} \right]^{3/2}}{-\frac{3}{4} \cdot \frac{y_1^2}{x_1^2} \cdot \frac{2 - \frac{x^2}{x_1^2}}{y \sqrt{1 - \frac{x^2}{x_1^2}}}}$$

$$= -\frac{4x_1^2}{3y_1} \cdot \frac{\sqrt{1 - \frac{x^2}{x_1^2}} \left(\frac{9}{4} \cdot \frac{x^2 \cdot y_1^2}{x_1^4} + \sqrt{1 - \frac{x^2}{x_1^2}} \right)^{3/2}}{2 - \frac{x^2}{x_1^2}}$$

When $x = 0$, $\rho_0 = \frac{-2x_1^2}{3y_1}$. But when $x = x_1$, $\rho_1 = 0$. As x tends to zero, and assuming $\sqrt{1 - \frac{x^2}{x_1^2}} = 1 - \frac{x^2}{2x_1^2}$, we have

$$\rho_x \rightarrow 0 = -\frac{4x_1^2}{3y_1} \cdot \frac{\left(1 - \frac{x^2}{2x_1^2} \right) \left(\frac{9}{4} \cdot \frac{x^2 y_1^2}{x_1^4} + 1 - \frac{x^2}{2x_1^2} \right)^{3/2}}{2 \left(1 - \frac{x^2}{x_1^2} \right)} =$$

$$= -\frac{2x_1^2}{3y_1} \cdot \left[1 + \frac{3}{2} \left(\frac{9}{4} \cdot \frac{x_1^2 y_1^2}{x_1^4} + \frac{x^2}{2x_1^2} \right) \right].$$

Accordingly (in the case of highly elongated aerostats), we have the approximate formula:

$$\rho_x \rightarrow 0 = -\frac{2x_1^2}{3y_1} \left(1 - \frac{3x^2}{4x_1^2} \right).$$

In the limit, when $x = 0$, we obtain, as above, using this formula:

$$\rho_0 = -\frac{2x^2}{3y_1}.$$

When x tends to x_1 ,

$$\rho_x \rightarrow x_1 = -\frac{4x_1^2}{3y_1} \cdot \frac{\sqrt{1 - \frac{x^2}{x_1^2}} \cdot \left(\frac{9}{4} \cdot \frac{x^2 \cdot y_1^2}{x_1^4} \right)^{3/2}}{2 - 1} = -\frac{9}{2} \cdot \frac{x^3 \cdot y_1^2}{x_1^4} \cdot \sqrt{1 - \frac{x^2}{x_1^2}}.$$

When $x = x_1$ we may put $\rho_1 = 0$, but the ends of the envelope will be rounded, so that the first derivative will become infinite when $x = x_1$. Thus, in the case of the intermediate curve, the radius of curvature will continuously decrease from the center toward the ends, even diminishing to zero.

406. An elongated cosinusoid may be expressed by the equation

$$y = y_1 \cos \left(\frac{\pi x}{2x_1} \right).$$

Hence we have

$$\frac{dy}{dx} = - \frac{\pi \cdot y_1}{2x_1} \cdot \sin \left(\frac{\pi x}{2x_1} \right); \quad \frac{d^2y}{dx^2} = - \frac{\pi^2 y_1}{4x_1^2} \cos \left(\frac{\pi x}{2x_1} \right),$$

$$\rho = \frac{\left[4x_1^2 + \pi^2 y_1^2 \sin^2 \left(\frac{\pi x}{2x_1} \right) \right]^{3/2}}{2\pi^2 x_1 y_1 \cos \left(\frac{\pi x}{2x_1} \right)}.$$

407. When $x = 0$, $\rho_0 = - \frac{4}{\pi^2} \cdot \frac{x_1^2}{y_1}$.

When $x = x_1$, $\rho_1 = \infty$, so that the ends of the curve will be

almost straight segments, and this is a great advantage in constructing our aerostat.

408. To sum up, when $x = 0$ the radii of curvature of a parabola, ellipse, intermediate curve, or elongated cosinusoid may be expressed, respectively, as:

$$\frac{1}{2}; 1; \frac{2}{3}; \frac{4}{\pi^2} = 0.405.$$

The multiplier $\frac{x_1^2}{y_1}$, being the same in all cases, may be omitted.

The least radius in the central part of the curve corresponds to the cosinusoid (about $2/5$), and the greatest to the ellipse.

At the ends of the curves, the radii will be as follows, in the same order as before:

$$\left(\frac{x_1^2}{2y_1} + 2y_1 \right) \sqrt{1 + \frac{4y_1^2}{x_1^2}}; \frac{y_1^2}{x_1}; 0; \infty$$

Thus, it will vary only slightly in the case of the parabola, decrease drastically in the case of the ellipse, even vanish in the case of the intermediate curve, and become infinite in the case of the elongated cosinusoid. At the same time, all the surfaces formed by rotating these curves about their respective axes are very smooth and differ very little with respect to the resistance they present.

Area of Maximum Longitudinal Section for Different Shapes

409. For a parabola (392) the area of the maximum longitudinal section is:

$$F_d = \frac{2}{3} y_1 x_1.$$

For an ellipse, we find:

$$F_d = \frac{y_1}{2} \left[x \sqrt{1 - \frac{x^2}{x_1^2}} + x_1 \arcsin \left(\frac{x}{x_1} \right) \right].$$

Now if $x = x_1$, the total area from zero to x_1 :

$$F_d = \frac{\pi}{4} \cdot y_1 x_1.$$

410. Clearly, then, the section of an ellipsoid is $\frac{3\pi}{8}$ or 1.178 times fuller.
For the intermediate curve:

$$F_d = y_1 \int \left(1 - \frac{x^2}{x_1^2} \right)^{3/4} dx.$$

411. Expanding in series and integrating, we find

$$F_d = y_1 x \left(1 - \frac{1}{4} \cdot \frac{x^2}{x_1^2} - \frac{3}{160} \cdot \frac{x^4}{x_1^4} - \frac{1}{179} \frac{x^6}{x_1^6} - \frac{5}{2048} \cdot \frac{x^8}{x_1^8} - \dots \right).$$

Discarding all but the first two terms,

$$F_d = y_1 x_1 \left(1 - \frac{1}{4} \cdot \frac{x^2}{x_1^2} \right).$$

The area from zero to x_1 will be equal to $\frac{3}{4} \cdot y_1 x_1$, i.e., slightly less than for an ellipse.

412. More exactly, taking three terms into consideration, we obtain:

$$F_d = y_1 x \left(1 - \frac{1}{4} \cdot \frac{x^2}{x_1^2} - \frac{3}{160} \cdot \frac{x^4}{x_1^4} \right),$$

which, when $x = x_1$, yields a slightly lower figure, viz.

$$F_d = \frac{117}{160} \cdot y_1 x_1 = 0.73125 y_1 x_1.$$

413. Taking all the terms computed in (411), we find 0.723225. For an ellipsoid, (409) gives 0.785398, i.e., an appreciably higher figure.

In the case of an elongated cosinusoid, the area of the principal longitudinal section will be

$$F_d = \frac{2}{\pi} y_1 x_1 \sin\left(\frac{\pi x}{2x_1}\right),$$

which, for $x = x_1$, yields $\frac{2}{\pi} \cdot y_1 x_1$.

This area is even smaller than that for a parabola, to be precise $\frac{\pi}{3}$ or 1.0472 times smaller.

Length of Arc of Principal Longitudinal Section

(384): 414. The length of the arc of a parabola from zero to x_1 is

$$s_1 = x_1 \left(1 + \frac{2}{3} \cdot \frac{y_1^2}{x_1^2} - \frac{2}{5} \cdot \frac{y_1^4}{x_1^4} \right).$$

For instance, when $\frac{x_1}{y_1} = 6$, $s_1 = x_1 \cdot 1.01821$.

415. For an ellipse (374):

$$s = \int \left[1 + \frac{1}{2} \cdot \frac{x^2 y_1^2}{(x_1^2 - x^2) x_1^2} - \frac{1}{8} \cdot \frac{x^4 y_1^4}{(x_1^2 - x^2)^2 x_1^4} + \dots \right] dx.$$

416. It is easy to integrate this expression. Restricting ourselves to two terms, we find

$$s = x + \frac{y_1^2}{4x_1} \cdot \ln \left(\frac{x_1 + x}{x_1 - x} \right),$$

or

$$\frac{s}{x} = 1 + \frac{1}{4} \left(\frac{y_1}{x_1} \right)^2 \cdot \frac{x_1}{x} \cdot \ln \left(\frac{1 + \frac{x}{x_1}}{1 - \frac{x}{x_1}} \right).$$

The equation is inapplicable when $\frac{x}{x_1}$ is close to unity. If we put

$$\frac{x}{x_1} = \frac{3}{4}, \quad \frac{y_1}{x_1} = \frac{1}{7},$$

we arrive at

$$\frac{s}{y_1} = 1.101224.$$

There are formulas for determining the total length of the circumference of an ellipse, but we shall have no need for these, since the ends of the ellipsoid of revolution must in any case be replaced with cones.

417. In determining the arc of an ellipse, we can also expand its equation

$$y = y_1 \sqrt{1 - \frac{x^2}{x_1^2}}$$

in series:

$$y = y_1 \left(1 - \frac{1}{2} \cdot \frac{x^2}{x_1^2} - \frac{1}{8} \cdot \frac{x^4}{x_1^4} - \frac{1}{16} \cdot \frac{x^6}{x_1^6} - \frac{5}{128} \cdot \frac{x^8}{x_1^8} - \frac{35}{256} \cdot \frac{x^{10}}{x_1^{10}} - \dots \right).$$

418. In the case of an intermediate curve, formula (375) no longer applies. But, on expanding the equation for an intermediate curve, we find

$$y = y_1 \left(1 - \frac{3}{4} \cdot \frac{x^2}{x_1^2} - \frac{3}{32} \cdot \frac{x^4}{x_1^4} - \frac{5}{128} \cdot \frac{x^6}{x_1^6} - \frac{45}{2048} \cdot \frac{x^8}{x_1^8} - \dots \right).$$

Hence, clearly, from the preceding equation, if the ratio $\frac{x}{x_1}$ is not too close to unity, both the ellipse and the intermediate curve can be regarded as parabolas, so that the length of the curves can be determined in conformity with the procedure established for a parabola.

419. The length of the arc of an intermediate curve is expressed, exactly, by the integral

$$s = \int \sqrt{1 + \frac{9x^2 y_1^2}{4x_1^4 \left(1 - \frac{x^2}{x_1^2}\right)^{1/2}}} \cdot dx.$$

420. Rectification of the elongated cosinusoid does not present any difficulties, aside from its complexity. In fact, the equation of the curve will be

$$y = y_1 \cos \omega,$$

where

$$\omega = \frac{\pi x}{2x_1}.$$

Here $\cos \omega$ may not be greater than unity.
The first derivative is:

$$\frac{dy}{dx} = -m \sin \omega,$$

where

$$m = \frac{\pi y_1}{2x_1},$$

m being always much less than unity.

Now, using formula (375), we find

$$s = \int \left[1 + \frac{m}{2} \cdot \sin^2 \omega - \frac{m^4}{8} \cdot \sin^4 \omega + \frac{m^6}{16} \cdot \sin^6 \omega - \dots \right] dx.$$

Limiting ourselves, for example, to two terms and integrating, we find

$$s = x + \frac{\pi y_1^2}{16x_1} \left(\frac{\pi x}{x_1} - \sin \frac{\pi x}{x_1} \right).$$

421. Putting $x = x_1$, we now find the length of the arc from zero to x_1 :

$$s_1 = x + \frac{\pi^2}{16} \cdot \frac{y_1^2}{x_1} = x + \frac{\pi^2}{16} \cdot \frac{y_1^2}{x_1^2} \cdot x_1.$$

Surface Areas of Different Bodies of Revolution

422. Let us now consider the surface areas of the bodies of revolution (376). In the case of an ellipse, formula (376) yields:

$$F = 2\pi y_1 \int \sqrt{1 - \frac{x^2}{x_1^2}} \cdot \sqrt{1 + \frac{x^2 y_1^2}{x_1^2 \left(1 + \frac{x^2}{x_1^2}\right)}} \cdot dx.$$

If, in view of the elongation of the metal envelope, we take

$\frac{ds}{dx} = 1$, formula (376) reduces to the simpler form:

$$423. \quad F = 2\pi \int y dx = 2\pi y_1 \int \sqrt{1 - \frac{x^2}{x_1^2}} dx,$$

which yields

$$F = \pi y_1 x_1 \left(\frac{x}{x_1} \sqrt{1 - \frac{x^2}{x_1^2}} + \arcsin \frac{x}{x_1} \right).$$

When $x = x_1$

$$F_1 = \frac{\pi^2}{2} \cdot x_1 y_1;$$

this is one-half the surface area of an ellipsoid of revolution from zero to x_1 .

424. But we can also find the surface area of an ellipsoid exactly. In fact, equation (423) yields

$$\begin{aligned}
 F &= \frac{2\pi y_1}{x_1^2} \int \sqrt{x_1^4 - x^2 (x_1^2 - y_1^2)} \, dx = \\
 &= \frac{\pi y_1}{\sqrt{x_1^2 - y_1^2}} \left[\frac{x}{x_1} \sqrt{1 - \frac{y_1^2}{x_1^2}} \cdot \sqrt{x_1^4 - x^2 (x_1^2 - y_1^2)} + \right. \\
 &\quad \left. + x_1^2 \arcsin \left(\frac{x}{x_1} \sqrt{1 - \frac{y_1^2}{x_1^2}} \right) \right].
 \end{aligned}$$

425. When $x = x_1$ we obtain

$$F_1 = \frac{\pi y_1 x_1}{\sqrt{x_1^2 - y_1^2}} \left[y_1 \sqrt{1 - \frac{y_1^2}{x_1^2}} + x_1 \arcsin \left(\sqrt{1 - \frac{y_1^2}{x_1^2}} \right) \right].$$

If the ellipse is infinitely elongated, then $\frac{y_1}{x_1} = 0$ and

$$F_1 = \frac{\pi^2}{2} \cdot y_1 x_1 + \pi y_1^2.$$

Neglecting the last term as infinitesimally small (compared to the first term), we arrive at formula (423).

426. For the surface area of the body of revolution formed by rotating an intermediate curve, we have from (373), approximately:

$$F = 2\pi y_1 \int \left(1 - \frac{x^2}{x_1^2}\right)^{3/4} \cdot dx.$$

Expanding and integrating, we have

$$F = 2\pi y_1 x \left(1 - \frac{1}{4} \cdot \frac{x^2}{x_1^2} - \frac{3}{160} \cdot \frac{x^4}{x_1^4} - \frac{5}{896} \cdot \frac{x^6}{x_1^6} - \dots\right).$$

427. When $x = x_1$, we find the surface area of the body of revolution from zero to x_1 , namely:

$$F = 2\pi y_1 x_1 \left(1 - \frac{1}{4} - \frac{3}{160} - \frac{5}{896} - \dots \right),$$

i.e., less than $3/4$ of the surface area of the circumscribed cylinder.

428. We obtain more exact results when, in accordance with (373), we find the integral:

$$F = 2\pi y_1 \int \left(1 - \frac{x^2}{x_1^2} \right)^{3/4} \cdot \left[1 + \frac{9x^2 y_1^2}{4x_1^4 \left(1 - \frac{x^2}{x_1^2} \right)^{1/2}} \right]^{1/2} \cdot dx =$$

$$= 2\pi y_1 \int \sqrt{\left(1 - \frac{x^2}{x_1^2} \right)^{3/2} + \frac{9y_1^2}{4x_1^2} \cdot x^2 \left(1 - \frac{x^2}{x_1^2} \right)} \cdot dx.$$

429. For an elongated cosinusoid, we obtain (assuming $ds = dx$, approximately):

$$F = 4x_1 y_1 \cdot \sin \left(\frac{\pi x}{2x_1} \right).$$

When $x = x_1$:

$$F_1 = 4x_1 y_1.$$

Accordingly, the surface area of the end section from x to x_1 will be:

$$F_1 - F = 4x_1y_1 \left[1 - \sin \left(\frac{\pi x}{2x_1} \right) \right].$$

430. We obtain, exactly:

$$F = 2\pi y_1 \int \cos \left(\frac{\pi x}{2x_1} \right) \sqrt{1 + \frac{\pi^2 y_1^2}{4x_1^2} \sin^2 \left(\frac{\pi x}{2x_1} \right)} \cdot dx.$$

This expression can easily be integrated, giving

$$431. F = \pi y^2 \left\{ \sin \left(\frac{\pi x}{2x_1} \right) \sqrt{\frac{4x_1^2}{\pi^2 y_1^2} + \sin^2 \left(\frac{\pi x}{2x_1} \right)} + \right.$$

$$\left. + \frac{4x_1^2}{\pi^2 y_1^2} \cdot \left\{ \ln \left[\sin \left(\frac{\pi x}{2x_1} \right) + \sqrt{\frac{4x_1^2}{\pi^2 y_1^2} + \sin^2 \left(\frac{\pi x}{2x_1} \right)} \right] - \ln \left(\frac{2x_1}{\pi y_1} \right) \right\} \right\}.$$

The formulas will be simpler if we introduce hyperbolic functions.

432. For an infinite aspect ratio, we obtain the familiar formula

$$F = 4x_1 y_1 \quad (\text{cf. equation (429)}).$$

Volumes of Different Bodies of Revolution

433. The exact volume of an ellipsoid of revolution from zero to x is:

$$U = \pi y_1^2 x \left(1 - \frac{x^2}{3x_1^2} \right).$$

The volume from zero to x_1 will be

$$U_1 = \frac{2}{3} \pi y_1^2 x_1^2.$$

434. On comparing this with the volume obtained by rotating a parabola, we find that the volume of the ellipsoid, given the same values for x_1 and y_1 , will be $5/4$ or $1-1/4$ times fuller.

435. The volume of an intermediate curve is expressed exactly, according to the general formula, by the integral

$$U = \pi y_1^2 \int \left(1 - \frac{x^2}{x_1^2}\right)^{3/2} dx.$$

Expanding and integrating, we find

$$U = \pi y_1^2 x \left(1 - \frac{1}{2} \cdot \frac{x^2}{x_1^2} + \frac{3}{40} \cdot \frac{x^4}{x_1^4} + \frac{1}{102} \cdot \frac{x^6}{x_1^6} + \frac{1}{384} \cdot \frac{x^8}{x_1^8} + \dots\right).$$

436. When $x = x_1$, we find approximately, confining ourselves to the terms given:

$$U_1 = 0.587 \pi y_1^2 x_1.$$

This volume is 1.103 times fuller than the parabolic volume.

437. The volume of the body obtained by rotating an elongated cosinusoid about its axis, from zero to x , is expressed exactly by the formula

$$U = \pi y_1^2 \left[\frac{1}{2} \cdot x - \frac{x_1}{2\pi} \sin\left(\frac{\pi x}{x_1}\right) \right].$$

When $x = x_1$, we have

$$U_1 = \frac{\pi}{2} \cdot y_1^2 x_1.$$

This volume turns out to be $16/15$ or $1^1/15$ times less than the volume of a parabolic envelope.

Moments of Envelopes of Different Shapes

438. The moment of the envelope of an ellipsoid is expressed exactly by the integral (370):

$$\begin{aligned} M_{\text{env}} &= \frac{2\pi y_1 q}{x_1^2} \int x \sqrt{x_1^4 - x^2 (x_1^2 - y_1^2)} dx = \\ &= \frac{2\pi y_1 q}{3 (x_1^2 - y_1^2)} \cdot \left[x_1^4 - y_1^2 \sqrt{x_1^4 - (x_1^2 - y_1^2) x^2} \right]. \end{aligned}$$

439. When $x = x_1$, then

$$M_{\text{env}} = \frac{2}{3} \pi q y_1 x_1 \cdot \frac{x_1^3 - y_1^3}{x_1^2 - y_1^2} = \frac{2}{3} \cdot \pi q x_1 y_1 \cdot \frac{x_1^2 + x_1 y_1 + y_1^2}{x_1 + y_1}.$$

440. This is the moment about the center plane (Fig. 30). We find the moment about a plane N on the basis of equations (438) and (439); we have

$$q (F_1 - F) (x + \Delta x) = M_{\text{env}_1} - M_{\text{env}},$$

where Δx denotes the distance of the center of gravity of the surface of the end ($F_1 - F$) of the envelope from the plane N; M_{env_1} is

the total moment, and M_{env} is the moment of that part of the envelope from zero to x .

We have, from this equation,

$$M_{\text{env}_N} = q (F_1 - F) \Delta x = M_{\text{env}_1} - M_{\text{env}} - q (F_1 - F) x,$$

i.e., the moment of the end of the envelope about the plane N (Fig. 30).

441. This equation is applicable to any shape. In the case of an ellipsoid, we find the moment (about N):

$$M_{\text{env}} = \frac{2\pi q y_1^3}{3 (x_1^2 - y_1^2)} \sqrt{x_1^4 - (x_1^2 - y_1^2) \cdot x} - q (F_1 - F) \cdot x.$$

F_1 and F are obtainable from (424) and (425).

442. In the case of an intermediate curve, the moment of the envelope from zero to x about M will, if we assume $ds = dx$ approximately, be equal to

$$M_{\text{env}} = \frac{4}{7} \pi q y_1 x_1^2 \left[1 - \left(1 - \frac{x^2}{x_1^2} \right)^{7/4} \right].$$

The total moment about M will be:

$$M_{\text{env}_1} = \frac{4}{7} \pi q y_1 x_1^2.$$

443. The moment of the end of the envelope $F_1 - F$ about the plane N is found, from (440), to be:

$$M_{\text{env}_N} = \frac{4}{7} \pi q y_1 x_1^2 \left(1 - \frac{x^2}{x_1^2} \right)^{7/4} - q (F_1 - F) x.$$

We find the difference $(F_1 - F)$ from equations (426) to (428).

444. For an elongated cosinusoid, the moment about the plane M will be, approximately:

$$M_{\text{env}} = 2\pi q y_1 \int \cos\left(\frac{\pi x}{2x_1}\right) \cdot x dx.$$

Integrating by parts and determining the constant of integration in the usual way, we find

$$M_{\text{env}} = 4q y_1 x_1 \left[x \sin \frac{\pi x}{2x_1} - \frac{2x_1}{\pi} \left(1 - \cos \frac{\pi x}{2x_1} \right) \right].$$

445. When $x = x_1$, we have

$$M_{\text{env}_1} = 4q y_1 x_1^2 \left(1 - \frac{2}{\pi} \right).$$

To determine the moment of the end of the envelope, we have formulas (440) and (429) to (431) at our disposal.

Moment of Lift Force for Envelopes of Different Shapes

446. In the case of an ellipsoid, we find exactly (with respect to the plane M):

$$M_{\text{gas}} = \frac{\pi}{2} \cdot a y_1^2 x_1^2 \left(1 - \frac{x^2}{2x_1^2} \right).$$

The total moment of the lift force

$$M_{\text{gas}} = \frac{\pi}{4} a y_1^2 x_1^2.$$

Here a is the specific lift force exerted by the filling gas.

447. The total moment M_{gas} of the end $U_1 - U$ relative to the plane N is found from a formula similar to (440), viz.

$$M_{\text{gas}_N} = a (U_1 - U) \cdot \Delta x = M_{\text{gas}_1} - M_{\text{gas}} - a (U_1 - U) \cdot x$$

where Δx is, as above, the distance from the center of pressure of the gas filling the end $U_1 - U$ of the envelope to the plane N (Fig. 30).

448. Thus, for an ellipsoid, we find, exactly, on the basis of the last formulas mentioned and formula (433):

$$\begin{aligned} M_{\text{gas}_N} &= \frac{\pi}{2} \cdot a y_1^2 \left[\frac{1}{2} x_1^2 - x^2 \left(1 - \frac{x^2}{2x_1^2} \right) \right] - \pi a y_1^2 \left[\frac{2}{3} x_1 x - x^2 \left(1 - \frac{x^2}{3x_1^2} \right) \right] = \\ &= \pi a y_1^2 \left[\frac{x_1^2}{4} - \frac{x^2}{2} \left(1 - \frac{x^2}{2x_1^2} \right) - \frac{2}{3} x_1 x + x^2 \cdot \left(1 - \frac{x^2}{3x_1^2} \right) \right] = \end{aligned}$$

$$= \frac{\pi}{2} \cdot ay_1^2 \left[x_1 \left(\frac{x_1}{2} - \frac{4}{3} x \right) + x^2 \left(1 - \frac{x^2}{6x_1^2} \right) \right].$$

449. In the case of an intermediate curve, the moment of the lift force from zero to x , relative to the principal cross section M , will [cf. general formulas (371)] be expressed exactly by the formula

$$M_{\text{gas}} = \frac{\pi}{5} \cdot ay_1^2 x_1^2 \left[1 - \left(1 - \frac{x^2}{x_1^2} \right)^{5/2} \right].$$

The total moment about the plane M (Fig. 30) is

$$M_{\text{gas}_1} = \frac{\pi}{5} \cdot ay_1^2 x_1^2.$$

450. The total moment of the lift force about the plane N may be expressed exactly, on the basis of the last two formulas, general formula (447), and formula (435), by the equation

$$M_{\text{gas}_N} = \pi ay_1^2 x_1 \left\{ \frac{x_1}{5} \left(1 - \frac{x^2}{x_1^2} \right)^{5/2} - x \left[\left(1 - \frac{x}{x_1} \right) - \frac{1}{2} \left(1 - \frac{x^3}{x_1^3} \right) + \right. \right. \\ \left. \left. + \frac{3}{40} \left(1 - \frac{x^5}{x_1^5} \right) + \frac{1}{102} \left(1 - \frac{x^7}{x_1^7} \right) + \frac{1}{384} \left(1 - \frac{x^9}{x_1^9} \right) + \dots \right] \right\}.$$

Since this formula may be used only when $\frac{x}{x_1} < 1$, the series will converge rapidly, and consequently only the first few terms will be needed.

451. In the case of an elongated cosinusoid, the moment of the lift force about the plane M, from zero to x, may be expressed exactly by the formula

$$M_{\text{gas}} = \frac{\pi}{2} ay_1^2 \left\{ x \left[\frac{x_1}{\pi} \sin \left(\frac{\pi x}{x_1} \right) + \frac{x}{2} \right] - \frac{x_1^2}{\pi^2} \left[1 - \cos \left(\frac{\pi x}{x_1} \right) \right] \right\}.$$

452. When $x = x_1$, we obtain the total moment about M, viz.:

$$M_{\text{gas}_1} = \frac{\pi}{4} \cdot ay_1^2 x_1^2 \left(1 - \frac{4}{\pi^2} \right).$$

453. The moment about N from x to x_1 is found from the expression

$$M_{\text{gas}_N} = \frac{\pi}{2} \cdot ay_1^2 \left\{ \frac{x_1^2}{2} - \frac{x_1^2}{\pi^2} \left[1 + \cos \left(\frac{x_1 x}{\pi} \right) \right] - xx_1 \left[1 + \frac{2}{\pi} \sin \left(\frac{xx_1}{\pi} \right) \right] + \frac{x^2}{2} \right\}.$$

If the distribution of the weight of the hoops supporting the envelope is proportional to the surface area, the moment of the hoops may be found as the moment of a surface of constant thickness.

The moments of the envelope and the lift force are an expression of certain forces which tend to destroy the envelope of the aerostat and its frame. For the time being, we shall find only the moment of an envelope of constant thickness. Actually, the envelope, the hoops, and the longitudinal girders may all vary in thickness, so that their moments should be determined with that possibility in mind. Clearly then, the problem of the moments can not be completely solved in this chapter, since we are not now in a position to derive the relation between the thickness of the envelope or the framing and the corresponding spatial coordinates.

Aside from the envelope moments and the lift force, there is one other force capable of exerting a crucial influence on the stability of the envelope: the pressure of the gas filling the aerostat, or the pressure (overpressure) at the lowest point of the envelope. This pressure may be infinitely variable, while the moments of the envelope of the lift force are dependent upon it only to a very slight extent, at least when the gas pressure is fairly high. I deal with this aspect of the problem in the next chapter.

IX. PRESSURE OF GAS ON CROSS SECTION OF AEROSTAT. CENTER OF PRESSURE.

454. For brevity I shall refer to the difference between the gas pressure and the air pressure at any point on the envelope of the aerostat simply as the gas pressure. This pressure is obviously the same for any horizontal plane. It depends on the pressure at the low point B of the envelope and on the height of a given point of the envelope above that low point (Figures 31 and 32). As before (Chapter VI), the pressure at the low point B will be expressed as the length y_3 of a column of gas or of a tube or appendix filled with the same gas as the aerostat. This tube is assumed to be open at the bottom.

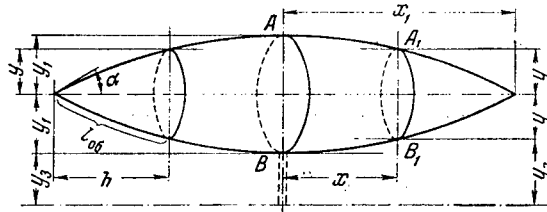

Fig. 31.

455*. So long as the axis is not tilted, the pressure in the direction of the longitudinal axis of the envelope will be the same, namely $y_3 + y_1$. The pressure at the lowest point of any cross section will be $y_2 = y_3 + y_1 - y$, where y is the radius of the cross section in question. The pressure at the highest point of a given cross section will be $y_3 + y_1 + y$.

The pressure at a point whose height relative to the lowest point of the cross section (Fig. 32) is y_z is given by the formula

$$y_2 + y_z = y_3 + y_1 - y_z + y_z.$$

456. In view of the symmetry of the pressure relative to the longitudinal axis of the envelope, the total gas pressure* P on any cross section of the envelope may be expressed quite simply, since the average pressure over the cross section may be assumed equal to the pressure along the longitudinal axis, namely

$$y_3 + y_1.$$

Thus:

$$F = \pi a y^2 (y_3 + y_1).$$

457. The pressure on the principal cross section is

$$P_1 = \pi a y_1^2 (y_3 + y_1).$$

* Rather, the total force.

If we put $y_1 = y_2$, then $P = 2\pi a y_1^3$.

If we also put $a = 1.2 \text{ kg/m}^3$, then $P = 7.54 y_1^3$. From the last

formula we readily see that the pressure on the principal cross section is proportional to the cube of the height of the envelope.

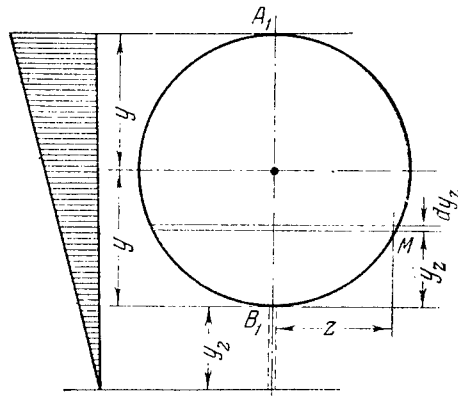

Fig. 32.

Formula (456) is the general formula in which $y = F(x)$.

458. The pressure P is applied nonuniformly over the cross section of the envelope and over the longitudinal girders, so that the center of pressure lies above the longitudinal axis; but it will increasingly approach this axis as the cross section diminishes, i.e., as we approach the end of the envelope.

The moment of this pressure P about the horizontal plane A_1 or B_1 may be expressed approximately, for the ends of the aerostat, as:

$$P_y = \pi a \left(y_1 + \frac{y_3}{3} \right) y^3.$$

459. We can find the position of the center of pressure and the magnitude of the pressure exactly for any cross section through the envelope (Fig. 32). The differential of the gas pressure on the cross section is

$$dP = a \left(y_2 + \frac{y}{z} \right) \cdot \frac{2zdy}{z}.$$

In accordance with the equation of a circle

$$z = \sqrt{y^2 - \left(y - \frac{y}{z} \right)^2}.$$

460. We may therefore express the pressure in terms of the integral

$$P = 2 \int a \left(y_2 + \frac{y}{z} \right) \sqrt{y^2 - \left(y - \frac{y}{z} \right)^2}.$$

Here (455) yields

$$y_2 = y_3 + y_1 - y.$$

This equation must be integrated with respect to y , assuming y to be constant.

461. Once this is done and the constants have been determined, we have

$$P = a \left\{ \frac{\pi}{2} (y_3 + y_1) y^2 - \frac{2}{3} \sqrt{(2y_3 y_1 - y^2)^3} - (y_3 + y_1) \left[(y_3 - y_1) \sqrt{2y_3 y_1 - y^2} + y^2 \arcsin \left(\frac{y - y_1}{y_3 - y_1} \right) \right] \right\}.$$

462. For instance, if we put $y = 2y_1$, we obtain the total pressure

$$P = \pi a (y_3 + y_1) y_1^2,$$

i.e., the familiar formula (457), which we have rigorously proved.

When $y = y_1$, then

$$P = a \left[\frac{\pi}{2} (y_3 + y_1) y_1^2 - \frac{2}{3} y_1^3 \right].$$

Putting $y_3 = y = y_1$, we find P for the center cross section through the envelope:

$$P = 2a\pi y_1^3 \left(\frac{1}{2} - \frac{1}{3\pi} \right);$$

the pressure on the lower half of the cross section will be slightly less than half the total pressure.

463. The differential of the moment M of the pressure with respect to a horizontal plane passing through the low point B of the cross section (Fig. 32) is, according to (459):

1

$$y_z dP = 2ay_z \left(y_2 + y_z \right) \sqrt{y_z^2 - (y - y_z)^2} dy_z .$$

¹Integrating this equation with respect to y_z and determining the constant of integration, we have

$$-\int y_z dP = M = ay_z \left(y_3 + y_1 + \frac{1}{4}y \right) \left[\frac{\pi}{2} y_z^2 - (y - y_z)^2 \right] \sqrt{2yy_z - y_z^2} -$$

¹The method of integration is not described, even though it is complicated, inasmuch as it introduces nothing basically new.

$$- \frac{y^2}{z} - y^2 \arcsin \left(1 - \frac{y_z}{y} \right) \Big] - a \sqrt{(2yy_z - y_z^2)^3}$$

$$\left[\frac{2}{3} (y_3 + y_1 + y) + \frac{1}{2} (y - y_z) \right] \cdot$$

464. When $y_z = 2y$, we find, for the total moment

$$\int y_z dP = a\pi y^3 \left(y_3 + y_1 + \frac{1}{4} y \right).$$

But when $y_3 = y = y_1$, we have for the center cross section

$$\int y_z dP = 2 \frac{1}{4} a\pi y^4.$$

465. Now, dividing the moment M of the total pressure by the value of the pressure (462), we find

$$\frac{M}{P} = y \left[1 + \frac{y}{4(y_3 + y_1)} \right],$$

i.e., the distance of the center of pressure from the low point of

the cross section B .

Since it is clear from the formula that this distance is greater than y_1 , we find that the center will consistently lie above the longitudinal axis, or above the center of the circle. The same formula also shows that the greater the pressure y_3 at the low point of the envelope and the greater the vertical dimension y_1 of the envelope the closer together these centers will lie.

466. For the center cross section, we must put $y = y_1$ in the last formula; we then have

$$\frac{M}{P} = y_1 \left[1 + \frac{1}{4 \left(\frac{y_3}{y_1} + 1 \right)} \right].$$

Clearly, the greater the value of the ratio y_3/y_1 of the pressure at the low point of the envelope to the vertical dimension $2y_1$ of the envelope, the closer the center of pressure will lie to the longitudinal axis.

467. Putting, for example, $y_3 = y_1$ we find

$$\frac{M}{P} = \frac{9}{8} y_1.$$

Once the position of the center of pressure is known, it is not difficult to find the gas pressure on the two longitudinal girders, assuming that the entire pressure is transmitted exclusively to these members. For example, in the case considered

here, the moment arms of the component forces are related as $\frac{9}{8} y_1$ to $\frac{7}{8} y_1$.

Accordingly, the ratio of the arms will be $9/7$. This means that the lower component will be related to the upper in the proportion of 7 to 9. When $y_3 = 0$, i.e., when the pressure at the low point is zero, we have

$$\frac{M}{P} = \frac{5}{4} y_1 ;$$

and accordingly, the moment arms of the component forces will be in the proportion of $\frac{5}{4} y_1$ to $\frac{3}{4} y_1$, and the forces will be in the proportion of 3 to 5. The upper force will thus be almost twice ($1-2/3$) as great as the lower force. Clearly, the ratio of the component forces will be closer to unity at the other cross sections.

468. The general formula for the ratio of the component forces is

$$\frac{1 + \frac{y}{4(y_3 + y_1)}}{1 - \frac{y}{4(y_3 + y_1)}} = \frac{4\left(\frac{y_3}{y_1} + 1\right) + \frac{y}{y_1}}{4\left(\frac{y_3}{y_1} + 1\right) - \frac{y}{y_1}} .$$

The ratio of the moment arms of the forces will be the reciprocal.

469. The mass moment of a narrow annulus of the envelope defined by two closely spaced parallel cross sections is

$$2\pi y q y \, ds, \\ z$$

where q is the weight per unit area of the envelope, and y is the distance of the cross section from the plane about which the moment is determined.

The moment of the other parts of the aerostat, included between the same parallel cross sections, may be designated as

$$P_y d. \\ z z$$

470. The moment of the lift force exerted by the gas at the same cross section will be

$$2 \\ \pi y y \, dy, \\ z z$$

If the loads and masses are so distributed that the total moment at any cross section is equal to the moment of the lift force at that section, then these opposing forces will cancel out and, by studying the longitudinal pressures acting on the envelope and the girders, we shall be able to examine the effect of the gas pressure alone. In this particular case we shall be free to ignore the moments due to gravity and the lift force exerted by the gas. The middle part of the aerostat may be so designed, but not the ends, which would then be too thin and fragile for practical purposes.

X. A SURVEY OF THE PRINCIPAL FORCES ACTING ON THE ENVELOPE
OF THE AEROSTAT; THEIR INTERRELATIONSHIPS

Longitudinal Forces

471. In view of the corrugated design of the envelope and the variation in its volume and shape, the tensile force in the longitudinal direction will evidently be highly variable, so that there will be some doubt as to the safety factor.

The longitudinal forces tending to destroy the aerostat must be resisted by the longitudinal girders alone. Thus, in studying the longitudinal forces I shall neglect the role of the envelope and, for the time being, consider only the four longitudinal girders (Fig. 1 and Fig. 6).

Any cross section, for example, AB (Fig. 31), will be acted upon by the following principal longitudinal forces:

- a) the weight of the envelope, which will produce the moment of the envelope;
- b) the weight of the longitudinal girders, hoops (which may be regarded as integral with the envelope), gondola, machinery, passengers, and cargo; the action of these forces will also be expressed as moments about the cross section under consideration;
- c) the lift force of the gas acting in the opposite direction, a factor which we have already discussed in some detail;
- d) the gas pressure at any cross section; this force depends on the degree of inflation of the envelope.

472. The first of these forces (gravity) places the upper pair of girders in tension and the bottom pair in an equal state of compression; the second (lift force) has the opposite effect, i.e., it produces a compressive stress in the upper girders and a tensile stress in the lower ones; finally, the gas pressure tends to place all the girders in tension.

Designating the moments of these three forces as M_T , M_G , and M_B , respectively, we find that the upper girders are acted upon by

the resultant

$$\frac{M_T}{2y} - \frac{M_g}{2y} + \frac{M_B}{2y} = \frac{M_T - M_g + M_B}{2y},$$

where y is the radius of the cross section, and M_B is the moment of the gas pressure relative to a horizontal plane passing through the point A.

473. Likewise, the force acting on the bottom girders will be expressed by the formula

$$-\frac{M_T}{2y} + \frac{M_g}{2y} + \frac{M_A}{2y} = \frac{-M_T + M_g + M_A}{2y},$$

where M_A is the moment of the gas pressure relative to B.

474. For the middle parts of the envelope at some distance from the ends, the moment of the envelope may equal to the moment of the lift force of the gas, i.e.,

$$M_T = M_g,$$

so that we shall then have to deal only with the tensile force produced by the gas pressure. But this does not apply nearer the ends of the envelope; there the moment of the lift force will be

negligible compared to the moment of the envelope (Chapter IX). Actually, the weight of the conical surface which terminates the envelope is proportional to the square of its linear dimensions, while the volume of the gas it encloses is proportional to the cube of the same dimensions. As a consequence, a decrease in the lift force will be realized much faster by reducing the surface area than by reducing the weight of the cone.

475. Neglecting the lift force of the end sections of the envelope, we find that the upper girders will be acted upon by a force

$$-\frac{M_T - M_B}{2y},$$

and the lower girders by a force

$$-\frac{M_T - M_A}{2y}.$$

The first of these forces is always positive, so that it can only place the girders in tension; the second, on the other hand, may be either positive or negative, depending on the circumstances.

If the moment of the gas pressure is greater than the moment of the envelope, it will produce a tensile stress in the girders; otherwise the soft or thin and flexible envelope will sag, and the ends will droop downward forming irregular folds.

476. The resultant for the conical ends of the envelope may be derived from the above complicated formulas, but it is simpler to take an independent approach (Fig. 31, left).

The gas pressure on the cone [cf. formula (462)]

$$P = \pi a \left(\frac{y}{3} + y \right) y^2 ;$$

the moment of this pressure about A or B:

$$M_g = \pi a \left(\frac{y}{3} + y \right) y^3 ,$$

which, by the way, is directly evident from formula (464), where the quantity $1/4y$, being relatively small, may be neglected.

477. The weight of the conical part of the envelope

$$q\pi y l_g ,$$

where l_g is the generatrix, and y is the radius of the base.

Its moment about points B or A will be:

$$M_T = q\pi y l_g \cdot \frac{h}{3} ;$$

but

$$h = l_g \cos \alpha$$

and

$$y = l \sin \alpha,$$

where α is the angle formed by the axis of the cone and its generatrix. Accordingly,

$$M_g = \pi a (y_3 + y_1) l^3 \sin^3 \alpha,$$

$$M_T = \frac{\pi}{3} \cdot q l^3 \sin \alpha \cos \alpha;$$

the ratio of the moments is expressed by the formula

$$\frac{M_g}{M_T} = \frac{3a(y_3 + y_1)}{q \cos \alpha} \cdot \sin^2 \alpha.$$

478. Clearly, this ratio will increase with the pressure at the lowest point y_3 of the envelope, and vary inversely with the

weight of the conical surface q . When $y_3 = y_1$,

$$\frac{M_g}{M_T} = \frac{6ay_1}{q \cdot \cos \alpha} \cdot \sin^2 \alpha.$$

Here the angle α may be found from the derivative dy/dx , since

$$\alpha = \arctan \left(\frac{dy}{dx} \right),$$

where $x = x_1$.

Under ordinary conditions, and even when the aspect ratio of the envelope is considerable, the ratio of the moments will be greater than unity, and therefore even the ends of a soft envelope will not sag.

479. Formula (477) may be recast in the form:

$$\frac{M_g}{M_T} = \frac{3a(y_3 + y_1) \left(\frac{dy}{dx} \right)^2}{q \sqrt{1 + \left(\frac{dy}{dx} \right)^2}} .$$

If the elongation is considerable, we may assume approximately that

$$\frac{M_g}{M_T} = \frac{3a}{q} \cdot (y_3 + y_1) \left(\frac{dy}{dx} \right)^2 .$$

480. So far, we have not considered the weight of the framework of the gondola and the live loads or their moments.

These loads are proportional to the length; thus the moments are approximately proportional to the square, while the moment of the gas pressure is proportional to the cube of the linear dimensions of the cone; consequently, if the cone is sufficiently small the mass moment will exceed the moment of the gas pressure, and then the envelope would sag, were it not for its rigidity and the rigidity of the longitudinal girders and other possible framing in the conical ends of the envelope. Accordingly, we may even neglect the gas pressure, and base the calculations exclusively on the strength of the rigid parts of the envelope.

481. Moreover, if we consider that the shape of the aerostat not only departs from that of a surface of revolution (Figures 1, 2, 3), but has an intermediate section in the form of an elongated cylinder (Fig. 1, Fig. 2), then the moment of the gas pressure at the ends will be approximately proportional to the square of the linear dimensions of the cross section, just like the moment of the girders, and so forth. Consequently, the gas pressure may even cancel out the dead weight of the framing, if the members are reasonably light and the central cylinder (Fig. 2) is sufficiently wide.

482. Referring, for the time being, to my early scheme for an airship carrying 200 passengers (Fig. 1), I shall present a few figures to illustrate the relations between the forces acting on the envelope of the aerostat.

For the sake of simplicity, let us assume that the load at any cross section corresponds to the lift force; then the effect of the gas pressure will be most apparent. But what force will it exert on the four longitudinal girders?

To solve this problem, we can make use of the simple formula (456), putting $y_3 = y_1$. We obtain

$$P = 2\pi a y_1^2 y_2,$$

or, taking into account the equation of the generatrix

$$y = y_1 \left(1 - \frac{x^2}{x_1^2} \right),$$

we have

$$P = 2\pi a y_1^3 \left(1 - \frac{x^2}{x_1^2} \right)^2.$$

You may remember that y_1 , the radius of the principal cross section, is 15 meters and that the length of the aerostat is $2x_1 = 210$ meters; I shall use the round figure of 200 meters and assume that $a = 0.001$ ton per cubic meter (where a is the specific lift force of the gas, in tons per cubic meter).

483. We now calculate P , the pressure acting on the four longitudinal girders, in terms of x and y (Table 3).

TABLE 3

x , meters	0	20	40	50	60	70	80	90	100
y , meters	15	14.40	12.60	11.25	9.60	7.65	5.40	2.85	0.00
P , tons	21.07	19.38	14.95	11.80	8.64	5.48	2.74	0.76	0.00

It turns out that at the center the pressure exceeds 21 tons. Even 10 meters from the end of the envelope, where the radius y is less than 3 meters, the pressure is 760 kg.

484. In computing this pressure, I assumed a circular cross section and paid no attention to the width of the center longitudinal strip (Fig. 2). But this last factor cannot be ignored, particularly at the ends of the envelope.

The area of the additional rectangular section (Fig. 1 and Fig. 2) is $2y_3b$, where b is the width of the section; on multiplying this area by the average gas pressure at the longitudinal axis, $a(y_3 + y_1)$, we arrive at the total supplementary pressure on the four longitudinal girders: $2ab(y_3 + y_1)y_1$ or, taking into account the equation of the generatrix:

$$2aby_1(y_3 + y_1)\left(1 - \frac{x_1^2}{x_1^2}\right).$$

Putting $y_3 = y_1$, we have

$$4aby_1^2\left(1 - \frac{x_1^2}{x_1^2}\right) = 4aby_1y_1.$$

485. Thus, for $x = 10$ meters we have $y = 2.85$ meters, and the supplementary pressure will be 171 kg for a width $b = 1$ meter.

As we approach the ends of the envelope, the relative intensity of this supplementary pressure will increase to the point where it completely predominates.

Nevertheless, if a gallery is designed to run the full length of the envelope or machinery is located near the ends, it would be impossible to rely exclusively on the gas pressure, since in this case, the moment could not balance the moment due to the dead load. We must then consider seriously whether the ends of the envelope and

their framing can withstand the resulting compression. Detailed calculations would be somewhat premature at this point; accordingly, I shall first turn to the transverse circumferential tension in a direction at right angles to the longitudinal axis of the aerostat.

Transverse Forces

486. If the aerostat is elongated and the longitudinal tension is weak, a narrow strip between two adjacent cross sections may legitimately be treated in isolation (Fig. 15).

We have found (159) that the gas pressure on unit surface area of the envelope is $a(y + y)$. If, for instance, we wish to know the pressure at the highest point of the center cross section, we insert in that formula, $a = 0.001$, $y = y = 15$ meters, $y = 2y = 30$ meters; we then find $3ay = 45$ kg per square meter of envelope surface.

487. Assuming a circular cross section (Fig. 31, 32), we obtain the following expression for the transverse horizontal pressure:

$$\int a(y + y) dy = \frac{a}{2} (y + y)^2 - \frac{a}{2} \cdot y^2 = \frac{a}{2} (2y y + y^2) = ay (y + \frac{y}{2}),$$

where, according to formula (455):

$$y = y + y - y.$$

Thus,

$$ay \left(y + \frac{y_z}{2} \right) = ay \left(y_3 + y_1 - y + \frac{y_z}{2} \right);$$

where y is the radius.

488. For the total pressure $y = 2y$, so that we get $2 ay_z$
 $(y_3 + y_1)$.
 For the center cross section $y = y_1$, so that we end up with
 $2ay_1(y_3 + y_1)$. When $y_3 = y_1$, the pressure will be $4 ay_1^2$. The width
 of the cross section is taken as unity.

489. The total pressure on the principal longitudinal section through the envelope may be expressed as the average pressure along the axis $a(y_3 + y_1)$ multiplied by the area of that section (378).

490. The moment of the transverse gas pressure about the low point is given by the formula

$$a \int (y_2 + y_z) y_z \cdot dy_z = a \left(\frac{y_2}{2} y_z^2 + \frac{y_z^3}{3} \right).$$

491. For the total moment of the pressure, putting $y = y$, we find:

$$2ay^2 \left(y^2 + \frac{4}{3}y \right),$$

but since

$$y^2 = y^2 + y^2 - y^2,$$

then

$$M = 2ay \left(y^2 + y^2 + \frac{1}{3}y \right).$$

492. Dividing this last expression by the pressure (488), we obtain the distance of the center of pressure from the low point of the section:

$$l = \frac{y \cdot (y^2 + y^2 + \frac{1}{3}y)}{(y^2 + y^2)}.$$

Clearly, the center of pressure lies slightly above the longitudinal axis of the envelope, but the closer to that axis the smaller the value of y relative to y_1 , or the closer the section to the end of the envelope.

493. For the center section $y = y_1$; again putting $y^2 = y_1^2$

we find that the distance to the center of pressure will be $7/6y_1$;

consequently, the ratio of the upper component of the pressure to the lower component will be as $7/6$ to $5/6$, or as 7 to 5.

Under the same conditions, the distance to the center of the longitudinal forces will be $9/8y_1$, i.e., slightly less (by $1/24y_1$).

494. If in the last formula we put $y = y_1$ and $y_3 = 0$, i.e., at the center section, we shall find that the center lies at a distance $4/3y_1$ above the lowest point, that is, again above the center of the longitudinal forces ($5/4y_1$), this time by $1/12y_1$.

495. There is a possibility of carrying out a more exact investigation of the transverse forces acting on a strip of the envelope (Fig. 15).

Imagine that the strip slides (or is positioned) over frictionless pulley blocks. It is clear that the tension would be the same over the entire length if the strip were weightless. Because of gravity, the tension in the direction of an element of the curve will be equal to some constant plus a function of the weight of the underlying portion of the envelope. Clearly, then, the minimum tension will exist at the low point of the envelope. This tension will increase continuously with the length of the element of the curve, and will attain a maximum at the high point of the envelope, at the height h .

Clearly each element ds of the envelope, weighing qds , adds an amount qdy to the tension. The tension on the envelope at any point may therefore be expressed by the integral

$$\int qdy + C = qy + C,$$

where C is the constant stress when $y = 0$.

Clearly, the tension on two elements of the envelope located at the same height y will be identical.

If the tension C_1 at the high point or, in general, at any

point, is known, the height of the point being h , then the tension at any other lower point will be $C_1 - q(h - y)$.

496. We can get an idea of the tension in the depression at the top of the envelope (Fig. 1), where it forms an angle 2α , from the magnitude of this angle and the corresponding load, assuming that the parts of the gondola are unconnected, or sufficiently flexible, or hinged. The greater the load and the larger the angle 2α the greater the tension. It is not difficult to derive a formula for the tension C in the depression. Thus,

$$C = \frac{P}{2 \cos \alpha},$$

where P is the part of the load acting on a given strip of the envelope.

Thus, the tension at any point will be given by the formula

$$\frac{P}{2 \cos \alpha} - q(h - y),$$

where h is the height or ordinate of the apex of the angle formed by the depression. For example, at the low point $y = 0$, and the tension will then be

$$\frac{P}{2 \cos \alpha} - qh.$$

Since the curve at any cross section can easily be drawn (see Chapter VI), there will be no difficulty in determining h and a , so

that the value of the tensile force can always be found.

497*. We have seen (Chapter VI) that the tension on an element is composed of two forces, one horizontal and the other vertical. The first is independent of the weight of the envelope (162) and is expressed by the integral

$$t_z = \int aydy = \frac{a}{2} \cdot y^2 + C.$$

If we apply this last equation to a vertical element of the curve whose ordinate is $(h_1 = y_3)$ (Fig. 15), the horizontal component t_z will vanish, so that we have

$$t_z = \frac{a}{2} (h_1 + y_3)^2 + C = 0.$$

Eliminating C from this equation we find

$$t_z = - \frac{a}{2} [(h_1 + y_3)^2 - y^2].$$

498. This formula renders possible an exact determination of the tension at the low point of the envelope. Thus, putting $y = b$, we find

$$t_{\min} = - ah_1 \left(\frac{h_1}{2} + y_3 \right).$$

The tension on the highest element of the curve is found by putting $y = h + y_3$ (Fig. 15):

$$t_{\max} = + \frac{a}{2} (h - h_1) (h + h_1 + 2y_3).$$

The different signs indicate that the tensile forces act in opposite directions.

499. The ratio of the maximum tension to the minimum tension:

$$\frac{t_{\max}}{t_{\min}} = - \frac{(h - h_1) (h + h_1 + 2y_3)}{h_1 (h_1 + 2y_3)}.$$

This ratio must always be greater than unity, according to formula (495) above, so that, when $y_3 = 0$:

$$\frac{h_2 - h_1^2}{h_1^2} < 1$$

and when $y_3 = \infty$

$$\frac{h - h_1}{h_1} < 1;$$

whence

$$\frac{h}{h_1} < 2 \quad \text{or} \quad \frac{h_1}{h} > \frac{1}{2}.$$

500. Equation (163) shows that once the derivative dy/dz and the tension t_z in the z -direction are known, we can always find the tension t_y in the y -direction. Once both components are known, it is easy to find the resultant, or the tension in the direction of the element ds of the curve. This will be:

$$\sqrt{t_z^2 + t_y^2} = t_z \sqrt{1 + \left(\frac{dy}{dz}\right)^2} = t_z \cdot \frac{ds}{dz}.$$

501*. The derivative in this equation is determined using formula (173), but an even simpler approach would be to eliminate ds/dz directly with the aid of formula (191).

Constants C_1 and C_2 are expressed in equations (181) and (182).

Finally, we find t_z using equation (497).

After all this, we get

$$\frac{ds}{dz} = \frac{2q(h - 2y) - ah(h + 2y_3) + 4qy_3}{2a(y^2 - y_3^2) - ah(h + 2y_3) + 2qh}$$

and

$$t_z \cdot \frac{ds}{dz} = \frac{a[2q(h - 2y) - ah(h + 2y_3) + 4qy_3] [(y^2 - y_3^2) - h_1(h_1 + 2y_3)]}{4(y^2 - y_3^2) - 2h(h + 2y_3)}.$$

502. If the curve is weightless, $q = 0$, and we have

$$t_z \cdot \frac{ds}{dz} = \frac{-ah(h + 2y_3) \cdot [(y^2 - y_3^2) - h_1(h_1 + 2y_3)]}{4(y^2 - y_3^2) - 2h(h + 2y_3)}.$$

In view of the weightlessness of the curve the value of this expression must be independent of the ordinate. This is confirmed by formula (189) relating h_1 and h .

503. These formulas may be verified in a simpler fashion. Let us put $y_3 = 0$ in the last equation; this means that the pressure at the low point of the envelope is zero. We then have

$$t_z \cdot \frac{ds}{dz} = - \frac{ah^2(y^2 - h_1^2)}{2(2y^2 - h^2)}.$$

Recalling the relation between h and h_1 , when both q and y_3 are equal to zero (189), and eliminating h , we find

$$t_z \cdot \frac{ds}{dz} = \frac{-ah_1^2}{2},$$

which is also clear from formula (498), when we put $y_3 = 0$.

504. In fact, if we verify (502) by eliminating h by means of (189), we obtain

$$t_z \cdot \frac{ds}{dz} = - ah_1 \left(\frac{h_1}{2} + y_3 \right),$$

i.e., formula (498). Hence we see that in this instance, i.e., when the curve is weightless ($q = 0$), the tension is in fact independent of y , or constant over the entire curve.

XI. MODIFICATION OF THE COMPONENTS OF A METAL AIRSHIP

The general character of a metal aerostat will be clear from my earlier writings (cf. "A Simple Study of the Airship" [Prostoye ucheniye o vozdushnom korable]) and from a reading of Chapter V of this book. But significant modifications may also be made in the general design of a gas-filled airship. These craft are capable of surprising variety. In this chapter I shall attempt to evaluate the advantages and disadvantages of various types of components.

Various Aerostat Systems

505. This is a very elegant system (Fig. 33). One could not possibly discern its quality simply from the diagram, however, since this drawing, like all the others in Chapter XI, is only schematic, i.e., the scale varies in different directions and for different components. The advantages of this system over those described earlier are as follows.

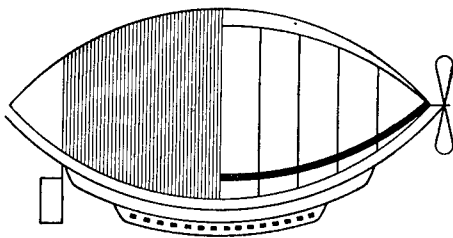

Fig. 33

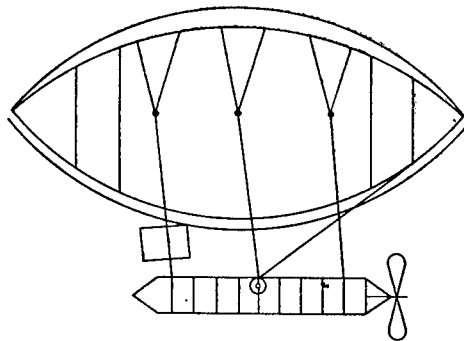

Fig. 34

a) Simple design of the gondola without exterior chains of complex design.

b) Reduction of drag, since all the chains are enclosed within the envelope.

c) Reduction in the total height of the airship.

d) Elimination of certain vibrations of the gondola.

e) Greater accessibility of the aerostat, particularly the joints.

f) Short distance between gondola and envelope.

g) Elimination of movable parts of black heating tube, and in general of parts transmitting vapors and gases.

h) Considerable stability of longitudinal axis of the aerostat, as a result of placing the propeller at the end of the envelope, thereby reducing the work of the regulator designed to preserve the horizontality of the longitudinal axis (horizontal control surface and longitudinal displacement of the gondola).

506. Calculations show that such a system is entirely realizable, but the opposite side of the coin must also be displayed, i.e., the reader must be acquainted with its shortcomings. These are:

a) Lower efficiency of the propeller, since the reverse air flow generated by the propeller will exert pressure on the envelope in a direction opposed to its motion; this unfavorable pressure will be relatively greater than in the case of a steamship, since in the latter instance it is possible to taper the stern of the ship and carry the propeller out beyond it.

b) Extra load on the ends of the longitudinal girders, making it impossible to use very powerful engines or a heavy propeller. If steam engines were used as a means of propulsion, the steam would have to be supplied from a considerable distance, viz., from the middle of the gondola.

c) The center of gravity of the gondola is too high.

d) The need for artificial tensioning of the envelope by means of interior chains strung between the longitudinal girders, which in turn requires heavy and complicated construction and con-

siderable work.

507. Thus, even though this system is quite attractive and presents some definite advantages, it still has certain shortcomings. One of these, for instance, is the problem of tightening the chains, without which it would be difficult to achieve stability of the longitudinal axis. It is true, of course, that even when exterior chains are used and the envelope is tightened by the weight of the gondola, there are still quite a few complications to contend with.

I shall return to the tensioning system in due course.

508. The system described here can be modified in such a way that one of the more serious flaws is eliminated, and another partially offset, but at the expense of making the airship more complicated and impairing the elegance of the design.

See Fig. 34. Here the design is a mixture of two extremes (Figs. 1 and 33). The tops of the center chains have a fixed support on the longitudinal axis of the envelope. The center chains, by which the gondola is suspended, are shown slightly out of the vertical owing to the action of the propeller. They must be free to slide freely up and down through slots in the envelope base and to deviate from the vertical position in response to the propeller action. Each chain has its own special slot. These slots are hermetically sealed by means of sliding plates (Fig. 35a).

In this design, the pressure on the propeller is applied more or less to the nose of the envelope, or to some other point on the longitudinal axis. Thus, an important advantage of the previous system (Fig. 33) is retained, while three crucial disadvantages are eliminated (viz., a, b, d): the propeller is placed where it really belongs, so that it does not generate a backflow of air that could add to the drag; the other disadvantages eliminated are the overloading of the ends of the longitudinal girders and the impossibility of utilizing powerful engines.

509. Moreover, the work done in tightening the chains would be halved, since the middle of the envelope is tightened naturally -- by the weight of the gondola and the loads it carries. Some of the passengers could be housed there, and others higher up, in a gondola directly adjacent to the envelope and suspended from the two bottom girders, as in the previous system (Fig. 33).

The horizontal trim of the aerostat could be regulated either manually or automatically, by displacing the center of gravity of the bottom gondola with the aid of an inclined cable (Fig. 34). The motion of the propeller and the variations in propeller speed will have almost no effect on the horizontal stability of the longitudinal axis, provided the chains are not allowed to reach the edges of the

slots.

510. There can be no longitudinal bending of the chains, because they ride freely in the slots, but transverse bending due to transverse oscillations of the gondola out of step with the oscillations of the envelope will be unavoidable.

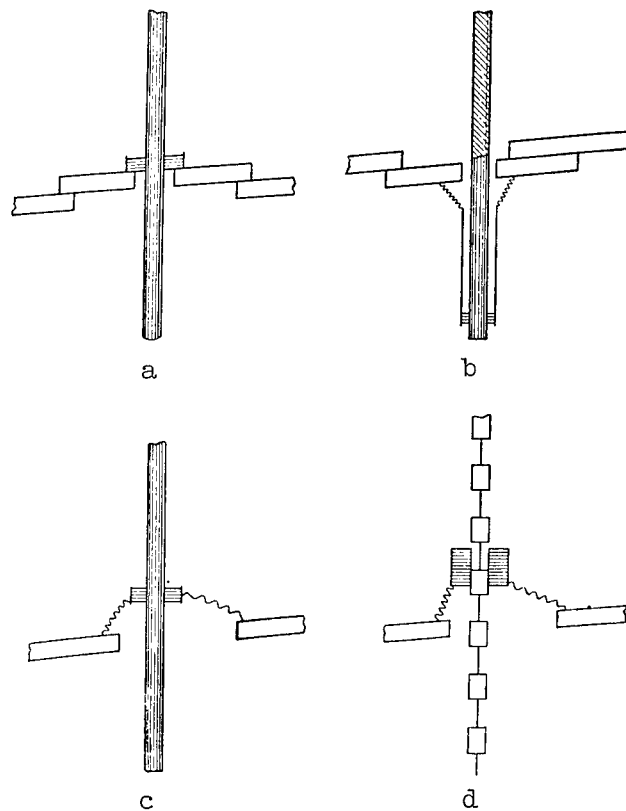

Fig. 35

This is a further disadvantage as compared with the preceding

system: the center of gravity lies high, so that the distance between it and the metacenter will be small*. Another disadvantage is the additional complexity of the design. Fig. 35a, for instance, shows the design of the longitudinal slots and their cover plates.

The chains need not be cylindrical, but may be irregular in shape, or may even consist of elliptical links like ordinary chains; but then special sleeves would be required, such as shown in Fig. 35b. In any case, the top of the chain would still have to be smooth and cylindrical.

511. This design has one further considerable advantage over the previous one. Small changes in the volume of the envelope are possible even without paying out the end chains, since the chains in the middle of the envelope are not connected to the bottom longitudinal girder, so that at this point the volume of the gas bag can vary within a certain range.

512. The mechanism depicted in Fig. 35a and Fig. 35b can be simplified as indicated in Fig. 35c and 35d.

The last of these drawings shows a chain made up of irregular links. The chain passes through a short sleeve, whose length exceeds that of the link itself; finally, a gastight apron extends between the edges of the sleeve and the edges of the slot. The sleeve and apron are held in place by a device, not shown in the diagram, which always remains inside the envelope.

513. Were it not for the difficulty of artificially tensioning the envelope by means of chains, I could recommend a system simpler than the preceding one. The new system, as is clear from an inspection of Figs. 1 and 36, is reminiscent of our basic design (Fig. 1), but differs in that all the chains can be placed in tension artificially, when the need arises.

Here, as in the basic system (Fig. 1), the propeller develops a couple, which tends to rotate the aerostat in the vertical plane, raising the nose; but, as I pointed out, this couple is readily balanced, on the basis of my calculations, by a small displacement of the center of gravity of the gondola using the diagonal tie.

514. A strong feature of this system is the fact that the

*As the bottom gondola is placed, as it were, on the longitudinal axis of the envelope.

length of the exterior chains remains unchanged, despite changes in the volume of the gas, so that each chain can consist of a single link with hinges at the ends. Another advantage of the system is the resulting stability of the lower gondola. Some inconvenience again results, however, from the artificial tensioning of the envelope and the location of the passengers high up in the top gondola.

Were it not for the tensioning problem, this design would be one of the best. Accordingly, in view of the crucial importance of methods of artificially tensioning the aerostat envelope and the associated difficulties, I shall proceed to describe and evaluate certain approaches to this problem.

Tensioning by Pulleys

515. Let us begin with the most practical approach: tensioning of the chains by means of pulley systems. These are indicated in Fig. 37. The force required to place any chain in tension is inversely proportional to the number of pulleys in the pulley system used to provide the tension. It is advisable to keep the number of wheels in each pulley system down to about ten, in order to avoid exerting heavy longitudinal forces on the bottom girder. If these forces are moderate, they could even contribute to the stability of the girder. Actually, as may readily be seen from the drawing, the two groups of longitudinal forces act in opposition to each other, toward the middle of the girder. These forces counteract the pressure exerted by the light gas, which tends to stretch the girders.

516. The pulley wheels will have the smallest diameter when ropes of some flexible but strong natural fiber are used as tackle. The pure, dry hydrogen inside the envelope of the aerostat would never harm these fibers. If ordinary chains are employed, the diameters of the pulley wheels will have to be larger. As for using wire cables, their flexibility increases as the strands become thinner, so that in this case the size of the pulleys will depend on the cable structure.

To turn the drum on which all the ropes are wound (Fig. 37), a machine giving a mechanical advantage of ten will be required. At any lower value the tensioning process would be irritatingly slow.

517. The advantages of this system of tightening the envelope are as follows:

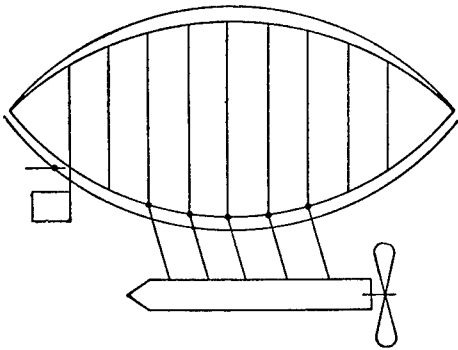

Fig. 36

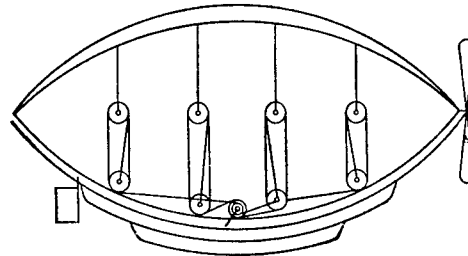

Fig. 37

a) The tension applied at the different cross sections of the envelope may be subject to some specific law; for example, the force may be made to decrease in proportion to the cross-sectional area of the envelope toward the ends.

b) The longitudinal girders, can be brought arbitrarily close to one another -- even almost to the point where the upper girders meet the lower ones.

c) Increased stability of the lower girders, as mentioned earlier.

d) Arbitrarily small force required to apply the necessary tension, since the force will depend on the number of pulleys used.

The disadvantages consist in a certain added complexity and the increased cost of the system. It is clear that the tensioning could just as well be achieved by some other block and tackle system, e.g., differential pulleys.

There is another tensioning system which is highly attractive for its simplicity, but advantageous only where the maximum necessary change in gas volume is extremely small (Fig. 38). The tensioning action is concentrated at one end of the envelope. When a considerable change occurs in the volume of the aerostat, which is sometimes necessary in practice, the pressure on the longitudinal girders will be so enormous as virtually to eliminate all prospects of utilizing

this simple design. Moreover, this method of tensioning or, more accurately, bringing the parts of the envelope closer together, does not produce a contraction proportional to the size of the cross section; on the contrary, tightening will be a minimum at the middle of the envelope and increase toward the ends.

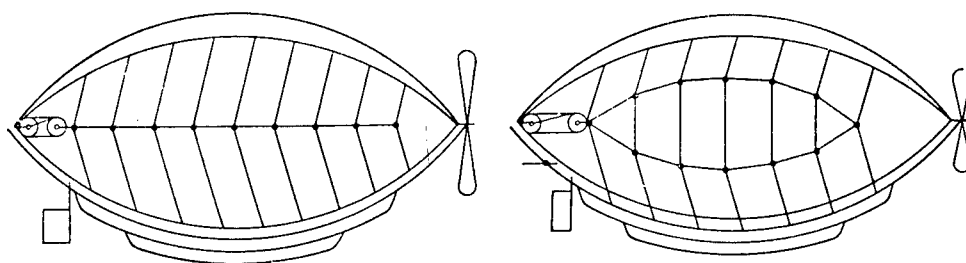

Fig. 38

Fig. 39

518. This last shortcoming can be eliminated by making a slight change in the original design. Thus, in Fig. 39 the tensioning reaches a maximum at the center cross section of the envelope. In general, by varying the length of the links (or rods), we can regulate the tensioning at will.

519. This method could be utilized more readily as a supplement to the system shown in Fig. 34. In this case the tensioning is applied simultaneously at both ends of the envelope (Fig. 40). Here most of the work is done naturally: by the weight of the suspended gondola; the fraction accounted for by artificial tensioning is less than half, and it is distributed between both ends of the aerostat. Consequently, the pressure on the girders is reduced to no more than one-fourth that obtained in the previous design (Fig. 39). Yet even with this airship system (Fig. 40), we find that preference should perhaps be given to a pulley tensioning system (Fig. 37) which can only add to the strength of the longitudinal girders.

520. In fact, the principal inconvenience encountered in applying the tension in the last three systems mentioned (Figs. 38,

39, 40) consists in the enormous longitudinal compression experienced by the girders, which, even though opposite in direction to the tensile stress developed by the gas, may exceed the latter, which is unconditionally and always true at the ends of the envelope. Actually, as the distance to the ends of the envelopes diminishes, the smaller the gas pressure tending to put the girders in tension, whereas the compressive stress due to the envelope tensioning forces will increase, in the first two systems, from the right end of the envelope to the left, where it reaches a maximum and inevitably crushes the girders. In the last system (Fig. 40), a compressive stress will develop at both ends and only the middle of the girders will be unaffected by the tensioning forces.

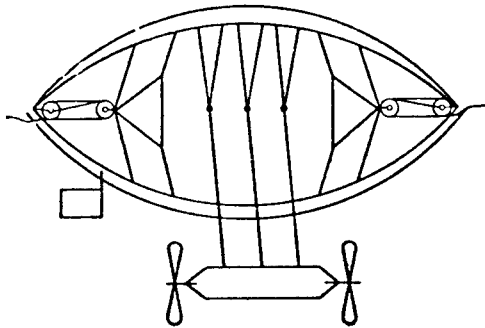

Fig. 40

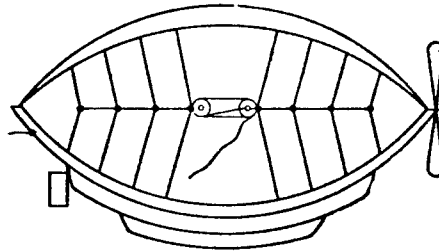

Fig. 41

521. Fig. 41 shows how we can arrange things so that both ends of the envelope are free of the longitudinal compressive stresses and so that these stresses increase from the ends toward the middle, like the tensile stresses exerted by the gas pressure. This is a highly advantageous design, as our calculations indicate, but it also has its Achilles heel.

The application of tension by means of a multi-block pulley system (Fig. 41) is very convenient: it can be done from either end of the envelope or from any point on the side or bottom (Fig. 41). The force required to apply this tension is negligible, because of the large number of pulleys employed, and therefore will not endanger

the shape of the envelope, even if the pulley rope runs vertically. The real difficulty is that this system will not stabilize the longitudinal axis of the aerostat. In fact, any deviation of the axis from the horizontal will tend to inflate one half of the envelope and deflate the other, the second half losing volume to match the increase in volume of the first half (if the aerostat is not severely tilted); the center of the lift force of the aerostat will be displaced horizontally, and the inclination of the axis may grow even worse. In order to achieve stable equilibrium both ends of the horizontal connecting chain (Fig. 41) will have to be lengthened, run out through the ends of the envelope, and fastened there; then there will be no horizontal displacement of the connecting chain and pulleys, and no displacement of the center of the lift force.

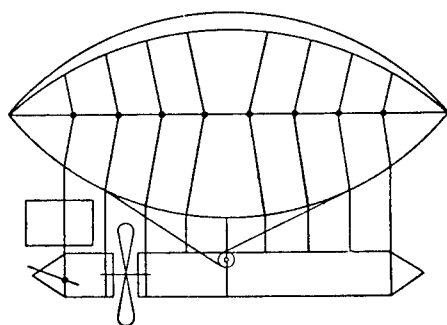

Fig. 42

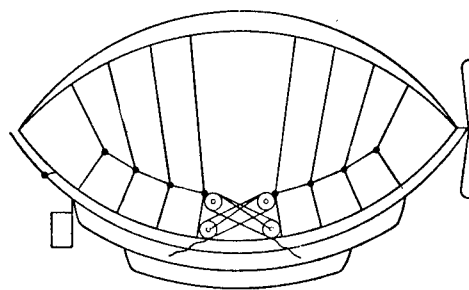

Fig. 43

Here the tensioning and relaxation of the ends of the longitudinal chain (Fig. 42) must be carried out simultaneously and according to calculations. In general, this system is by no means as simple as it appears at first glance.

522. Nevertheless, it is worthwhile considering this system seriously, for it makes possible the displacement of the center of the lift force in the horizontal direction. The gas volume undergoes almost no change, because ordinary pulley tensioning is not used and the distance between the blocks remains the same as before,

while the horizontal chain is displaced to the right or left, with the result that the center of the lift force is displaced likewise. The displacement of this center is a powerful means of dealing with any tendency of the longitudinal axis of the aerostat to deviate from the horizontal.

523. The center of the lift force can be displaced in the design of Fig. 40 also, provided the distance between the blocks is shortened on the right, and increased by the same amount on the left, or vice versa.

524. Fig. 42 shows an arrangement of the chains for displacing the center of the lift force in a system where the envelope is placed in tension by natural means, i.e., by using the weight of the gondola (Fig. 1).

525. Fig. 43 illustrates another notion on applying tension, where there is no need to fasten the connecting chain at the ends of the envelope; this system does not stand up to criticism, however. Actually, it is not bilateral, with the righthand chains reacting against those on the left; here each half of the chain system reacts against the lower girder. The vertical component of this force tends to lift part of the girder. This force is tremendous and variable, so that it cannot be balanced by the constant gravity force.

Screw Tensioning

526. The envelope could also be placed in tension by means of screws, as shown in Fig. 44. The drawbacks of this approach are:

- a) high friction;
- b) heavy weight of screws;
- c) twisting of screws;
- d) difficulty of turning screws simultaneously;
- e) prevention of twisting of upper pairs of chains or braces.

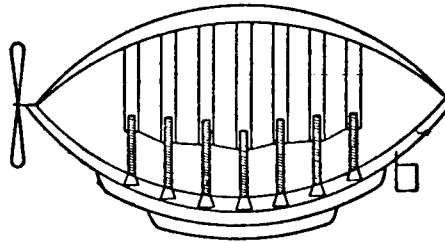

Fig. 44

Devices Used in Gravity Tensioning

527. As we saw from Fig. 1, this natural method of applying tension requires special devices to keep the longitudinal axis of the aerostat horizontally stable. Some of these devices have already been described in my earlier writings (cf. "Simple Study of the Airship" and "The Metal Dirigible").

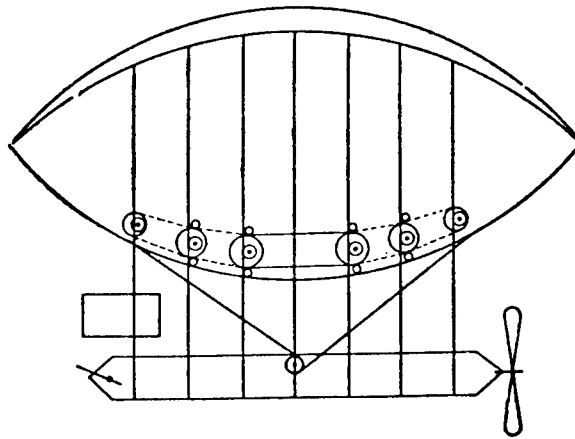

Fig. 45

Figs. 45 or 46 illustrate in schematic form the most elegant of these devices.

As the volume occupied by the gas increases, the chains are drawn into the envelope simultaneously and symmetrically about the plane of the center cross section. There is no need to worry about the irregular expansion or integrity of the envelope, so long as the volume does not approach the maximum, where the aerostat assumes the shape of a surface of revolution (neither the supports of the wheels nor their teeth are shown in the drawings; the chains are shown smooth).

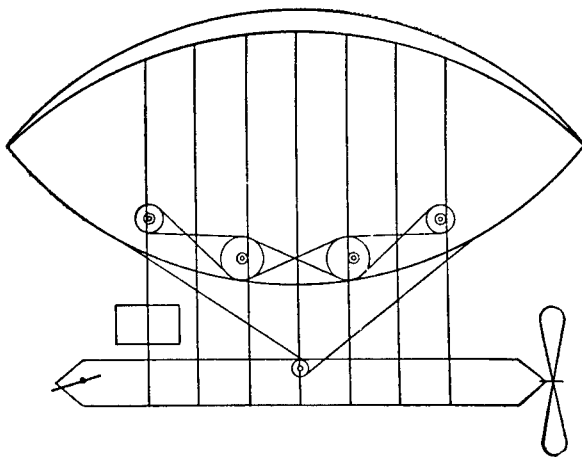

Fig. 46

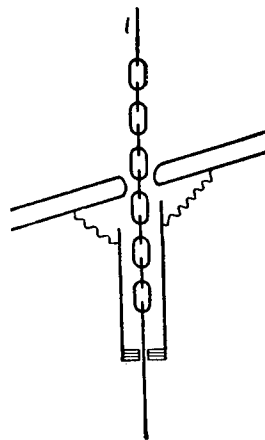

Fig. 47

The chains running over the toothed wheels and the chain portions of the vertical rods may take the ordinary form, i.e., they may consist of an alternating series of mutually perpendicular elliptical links (Fig. 47).

Any gas leakage through the chain openings can be prevented by means of the device depicted in Fig. 35b, except that the sleeve will point downwards, i.e., lie outside the aerostat envelope (Fig. 47).

The chains must be prevented from slipping off the wheels by means of special rollers or grooves.

It is clear from the foregoing that the mechanism is far from being as simple as the apparent elegance of the basic design led us to believe. However, the chain system in Fig. 46 is simpler; simpler still is the method used to seal in the gas when smooth rod-chains are employed (Fig. 9). In any case, it would be foolish to trust to this device before it has been tested in actual practice.

528. Something more elementary is depicted in Fig. 48, which shows the envelope from below, or a plan view of the parts of interest. Here on emerging from the envelope each series of smooth chains (Fig. 9) is gripped on both sides by a simple locking device. The action of this device makes the vertical chains integral with the lower longitudinal girders (Fig. 48 top).

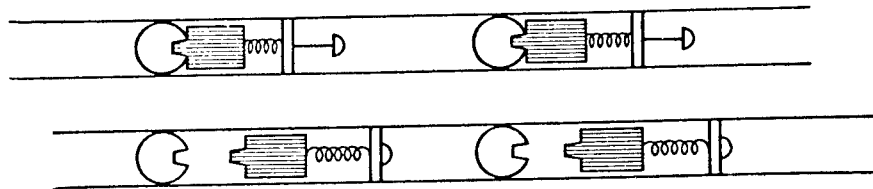

Fig. 48

Reversing the locking movement disengages the chains which are then free to travel into and out of the envelope (Fig. 48 bottom).

529. The chains are usually locked in this way to the lower longitudinal portion of the envelope. But if the gas is under high pressure and tends to expand the envelope, which will always be apparent from the visible bulge near the lower girders, the locking devices (Fig. 48) are briefly operated to free the envelope from the vertical chains. When the envelope has expanded to take on its natural shape, which will be apparent from the absence of convexity or concavity at the lower girders, the chains are locked again (Fig.

48 top), so that the horizontal stability of the longitudinal axis is secured.

During disengagement (Fig. 48 bottom), an irregular expansion of the envelope may occur, i.e., there may be an unbalanced (asymmetrical) movement of the chains resulting in horizontal displacement of the center of the lift force, so that the airship tilts. To avoid this, the maneuver must be executed quickly and immediately, while the longitudinal axis is horizontal; this can always be checked against the readings of a sensitive level.

531. For even greater security, one group of vertical chains (Fig. 1) may be disengaged or freed first and, once that group has been secured, we can proceed to the other, then back to the first, and so on, until the envelope has sufficiently expanded. In this case, the two parallel series of vertical chains used to suspend the gondola could be particularly useful.

When the gas pressure is low and the airship again is in danger of losing horizontal stability, the chains are likewise disengaged from the envelope as described, either successively or, if possible, all together, so that the envelope rides up the chains and assumes its normal shape.

If some or even all of the locking devices should fail to engage in the recesses in the links of the vertical chains, a slight vibration of the aerostat or the general expansion or contraction of the envelope will correct the situation. As a last resort, the aerostat could safely be brought down on a flat surface in order to eliminate any excess or lack of gas pressure and restore the normal shape of the envelope. However, even if the surface is not flat, the gondola could still be correctly adjusted by means of a level and anchor chains of different length. It should not be forgotten that the recesses lie in the intermediate, very short and sturdy links, so that the chains can swing without being damaged after they have been secured [cf. (131)].

532. Another type of mechanism for fastening the chains inside the envelope, where the tension is applied by gravity, is shown in Fig. 49. This is a familiar arrangement, but it must be remembered that in gravity tensioning with the longitudinal axis horizontal, the stress in the oblique secondary chains serving to secure the principal chains is very small, in fact virtually zero, if we ignore such factors as friction, the weight of the chains, and other comparatively minor forces. In the case of artificial tensioning (Figs. 37 to 43) by means of a similar device the picture is entirely different. The purpose of the proposed mechanism is not to apply tension but to secure the chains to resist the forces associated with tilting

of the longitudinal axis of the envelope. Therefore, this auxiliary system can be extremely light and cannot even be compared with the otherwise similar system employed for artificial tensioning of the envelope.

533. A natural tensioning system could also be secured in accordance with Figs. 37 to 43. The pulley systems shown in Fig. 37 and Fig. 43 are to be preferred. The pulley system is preferable because the securing of the tensioning cables can easily be adapted to the degree of tension applied.

Does a Gravity Tensioning System Have to be Secured?

534. We have discussed certain more or less realizable techniques of securing gravity tensioning systems in order to achieve horizontal stability of the longitudinal axis of the airship; but all these devices are excessively complicated and, consequently, the question arises: would it not be possible to dispense with securing the gravity tensioning system altogether?

Figs. 49, 50, 51 indicate that this problem is amenable to solution.

The tensioning and compression of the envelope occur predominantly near the center; but the further we go from the middle, the less they become, and the shape of the cross section of the envelope increasingly approaches a circle.

535. When the aerostat is tilted, the gas no longer is able to expand those parts of the envelope remote from the center, so that the center of the lift force is slightly displaced toward the raised end of the aerostat. When the aspect ratio of the aerostat is small, stability of the longitudinal axis may be achieved. Ultimately, this question can only be solved by experience with small aerostats or with bags of the same shape immersed in water. Experimentation will also determine the largest possible aspect ratio of an envelope using this simple system under these or other conditions.

The deficiency in the design lies in the fact that the volume change is less, since only the center portion of the envelope is drawn in, while its shape is less regular; moreover, the aspect ratio too could hardly be considerable. The advantage of the system lies in its simplicity and in the use of a shortened gondola.

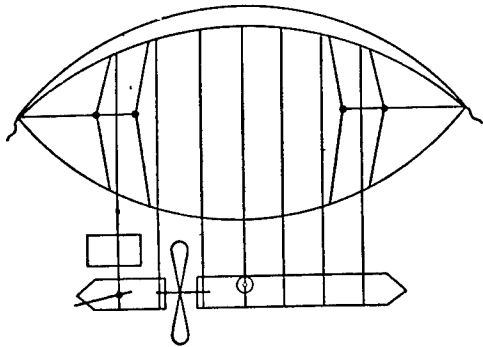

Fig. 49

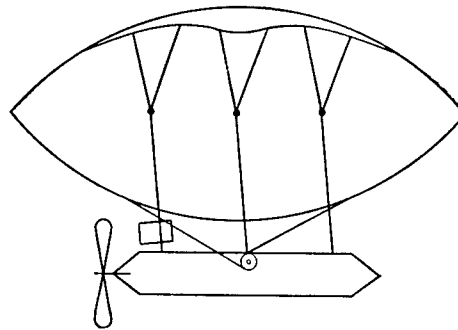

Fig. 50

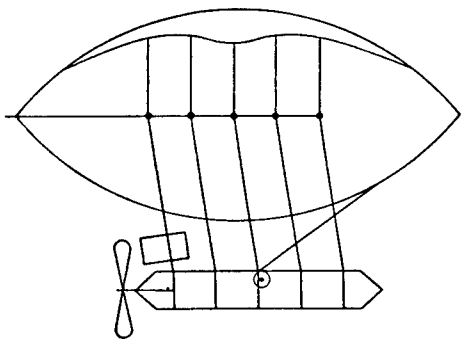

Fig. 51

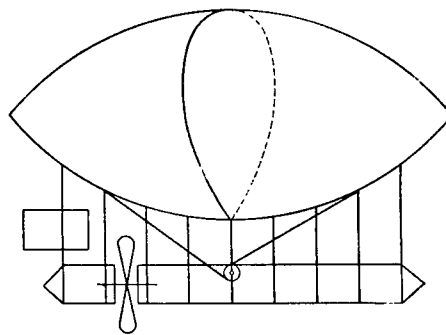

Fig. 52

Complete Absence of Tensioning

536. If the aspect ratio of the envelope is small, we can dispense with tension applied from the top altogether, i.e., we can do without the interior chains (Fig. 52).

The design will be even simpler if the gondola is secured directly to the bottom girders (Fig. 53).

The weak point in these systems (Figs. 52 and 53) is the extremely low stability of the longitudinal axis. To eliminate this drawback, we must:

a) either inflate the envelope hard, but then the volume of the envelope will no longer be free to vary, and that is inadmissible;

b) or reduce the aspect ratio, which complicates the design; furthermore such an airship would lack the proper speed because of the increased drag;

c) or else let the gondola hang low; but this would again increase the drag and create a couple, which would be difficult to counterbalance, unless we put a propeller at one end of the envelope; but this last proposal is also not very practical, as we have seen.

537. The drawbacks of this system may be eliminated at the cost of complicating the design. We can resort to the familiar solution of an air ballonet variably inflated inside the envelope (Fig. 54), a device which seems to work excellently, since it not only gives horizontal stability but also the opportunity of avoiding folds in the outer envelope.

Actually, by inflating the ballonet with air, we can keep the volume of the outer envelope unchanged no matter what changes occur in the density of the atmosphere surrounding the airship (or even in the density of the gas), and at the same time the shape of the envelope will also remain approximately the same. Maintaining the shape of the envelope would also mean the elimination of corrugated metal as a structural material. A shadow lies over these encouraging inferences for the following reasons:

a) the shape of the envelope is kept only approximately constant;

b) it is also difficult to keep the shape constant in that the volume of the outer envelope cannot be kept exactly the same;

c) the shape of the aerostat must change in response to unavoidable tilting of the longitudinal axis of the aerostat, because in a smooth envelope furrows or folds will inevitably appear;

d) Furthermore, a smooth envelope is very difficult to build, since the aerostat must then be constructed in either a convex

or inflated form;

e) inflating the envelope will also be difficult in this state. On completion of this operation and certain other necessary steps, it is certain that folds and furrows will have formed in the surface of the envelope.

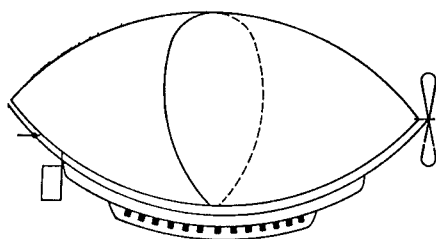

Fig. 53

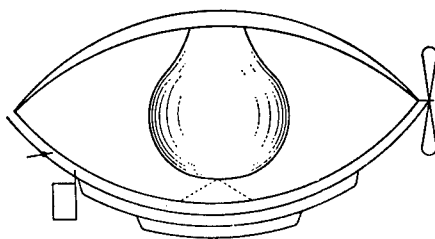

Fig. 54

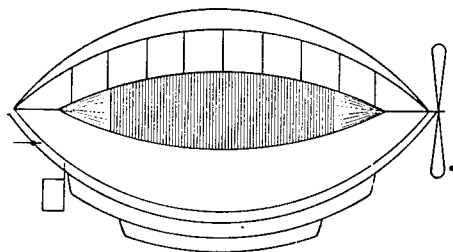

Fig. 55

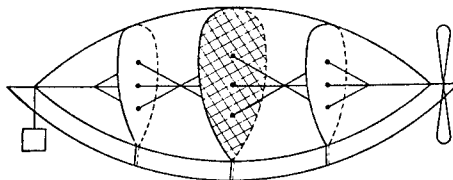

Fig. 56

538. But there is more to it than this. We still must ask ourselves what the inner gas bag will be made of. If it is made

of some organic material, then it will not matter that the aerostat itself is made of the same thing, since the ballonnet cannot be small, and consequently diffusion will be enormous; accordingly, some time after the airship has been inflated, we shall be carrying a load of explosives, a veritable mine, at the very heart of the aerostat, not to speak of the loss of gas and loss of lift force, all of which I pointed out some time ago.

539. If we make the bag of metal, it will necessarily have to be given an elongated shape, because its volume must vary over a wide range, and folds must not develop in the process. In this case the bag will have to be suspended from the upper girder (Fig. 55).

All this is not at all simple and gives rise to various complications. For instance, if the aerostat is tilted the heavy gas in the internal gas bag will be forced downward, thereby adding to the weight of the drooping part of the airship and simultaneously contributing to the further departure of the longitudinal axis of the ship from the horizontal; in order to forestall this possibility, therefore, some extra device will be required to put the envelope of the ballonnet in artificial tension. A soft bag, i.e., a bag made of some organic material, has the same disadvantage of contributing to the tilting of the longitudinal axis of the ship. I shall not dwell upon the need for a pump to inflate the ballonnet or a motor to drive the pump, since these are things that can be realized without much difficulty.

540. Enough has been said to enable us to reject completely any idea of using ballonnets in metal aerostats. Their use is ill-advised for the further reason that an airship keeping its volume consistently the same must develop a great deal of power to force its way through a denser medium; whereas an aerostat with no interior gas bag will contract in a denser medium, and therefore pass more easily.

However, there is one other means of providing for the stability of the longitudinal axis and at the same time dispensing with an interior ballonnet and the difficulties associated with it. This is by means of transverse bulkheads of very light and flexible material (Fig. 56).

The advantages of this system are as follows:

a) The aerostat can be made highly elongated, which will make the metal envelope much easier to design, since it reduces the folds or waves in its surface. The sharp taper will also contribute, to a certain extent, to the speed of the aerostat.

b) Diffusion is eliminated; the bulkheads may also be

mechanically permeable to a certain extent. Only then it will be necessary to provide communication between the compartments while the airship is at its moorings, in order to restore the normal quantities of gas.

c) By making the bulkheads convex in a given direction by means of ropes, we can increase the lift force of either end of the aerostat and thereby exert constant control over the horizontal trim.

d) The sum of the surface areas of the bulkheads will be only slightly different from the surface area of the ballonnet, whereas their quality can be greatly inferior.

e) The aerostat will contract and shrink in a dense medium, thus creating less drag than an aerostat with a ballonnet inside. In general, the shape of the aerostat in the vertical direction is elongated and reminiscent of the shape of most fish, which facilitates vertical motion, in particular climbing.

f) For the same reason, the transverse stress on the envelope will be reduced, the envelope will be stronger, or given the same strength the aerostat may be larger and have a greater load-carrying capacity.

The extreme simplicity of the design of this airship obliges us to consider it even more attentively. This is the system, I might add, which proved to be the most practical in my first experiments on the design of a metal envelope. Even at that early time it was possible to fabricate a smooth envelope with soft folds covered by metal covers. Thus, we can minimize the size of the metal bag while retaining a large aspect ratio, and consequently a high speed (cf. 342 to 346).

Nor should we not forget that an aerostat with interior bulkheads would be far safer, since in the event of damage to the envelope leakage of gas will be restricted to one compartment.

The disadvantages of the system are as follows:

a) The weight of the bulkheads and their connecting network (for rhombic network, see Fig. 56) acts on the girders and stiffening hoops, thereby complicating the shape of the envelope and requiring special modifications of the design of the framing. But the larger the bulkheads the less noticeable this particular drawback will be; only when the number of bulkheads is large do we encounter another serious difficulty: the complexity and size of their surface area.

b) Another disadvantage resides in the fact that soft envelopes readily yield under the pressure exerted by the gas, and consequently contribute to a constant, though slight oscillation of the longitudinal axis and harmful deformations of the metal envelope.

In order to ensure safety in the event of damage to the metal envelope, it would be wise to make the interior of the envelope consist entirely of cells each, say, 1 or 8 cubic meters in volume. These partitions, both longitudinal and transverse, must, of course, also be made of soft material. This system would more or less nullify all the above shortcomings, not to mention the fact that it also offers maximum safety.

But unfortunately, this is not the case. In fact, stability is only achieved if the longitudinal partitions are stretched (and even that is not enough). But they cannot be stretched, since the general shape of the envelope varies constantly and for that reason the longitudinal partitions would either tear or shrivel up in response to volume changes; neither prospect is tolerable, so that the entire system is a dubious one at best*.

Conclusions Concerning the Above Designs

541*. Only extensive and detailed calculations, and even more important, experience can definitively decide which of the systems described is best and most practical, and under what circumstances.

Nevertheless, turning to the metal airship in its pure form (i.e., with no bulkheads made of organic material), we cannot refrain from suggesting to the reader one more airship design deriving from those already described (Figs. 34, 35, 37, 50). Our intention is to choose the best design. It is preferable that the envelope be tensioned naturally -- by the weight of the gondola, and that the pressure on the propeller be transmitted to the longitudinal axis of the aerostat; but this must not involve moving the propeller to the end of the envelope. I accept all of these points (Fig. 34) in my new design. I shall also rely on the best method available for securing the chains by means of pulleys (Fig. 37). I should also remind the reader of the system shown in Fig. 50, part of which I shall introduce into the new design, since the ends of the envelope will not be subjected to tension to any great extent, so that they will

be close to circular in cross section. I shall minimize the number of vertical chains in order to achieve maximum simplicity of design. Because of the small number of chains and slots, I shall adopt the most refined method of closing the slots (Fig. 35). In order to reduce gondola weight and further simplify the design, I shall concentrate the principal loads on the vertical chains: these loads are the motors, fuel supplies and provisions, equipment carried on board, etc. The cabins or staterooms must be close to the principal chains. The chains may be replaced by solid cylindrical rods or, at least, the part of the chain that slides through the envelope may be rigid if desired. For safety reasons, this part may consist of a cylindrical tube with a metal cable running inside. The metal cable will save the day if the tube should snap. The chain connections, controls, etc., will all be concentrated in the gondola. The catwalk under the lower part of the envelope will be open, light, and designed merely to facilitate inspection of the joints in the envelope, and the chains, rods, and tubes. In case of need, the propeller could be raised so that the blades do not extend beyond the gondola floor as they rotate.

XII. DESIGN OF CERTAIN COMPONENTS OF A PARABOLIC
AEROSTAT, AND THEIR WEIGHT*

Center of Wind Pressure on Envelope

542. In general, the top and bottom longitudinal girders are unequal. I shall assume that the longitudinal axis is a straight line passing through the ends of the envelope or the ends of the girders (Fig. 57).

When the aerostat is in independent flight, the air stream will exert a certain pressure on the envelope, the location of the center of pressure varying with the circumstances. The exact location will depend on the ratio of the lengths of the longitudinal girders or on the ratio of their rises h_1 and h_2 . For instance, in

Fig. 11 the bottom diagram depicts an envelope in which the center of pressure lies close to the center of the lift force developed by the gas, whereas in the middle diagram the center of pressure lies lower, and in the top diagram higher than this point.

543. When the aerostat is in independent uniform motion, the thrust of the rotating propeller will be equal to the pressure of the air stream or the wind pressure on the surface of the airship. If the propeller is mounted on a relatively stable gondola, then the center of pressure will coincide with the geometrical center of the propeller or its axis. Such a system is, in fact, depicted in Fig. 1. But if we take a better system (Fig. 33, Fig. 34), the center of thrust will lie close to the longitudinal axis of the envelope. It should actually coincide with the center of wind pressure on the envelope. Equilibrium requires the coincidence of these two centers,

*To simplify the calculations, in this chapter I assume the shape of the aerostat to be parabolic, even though a different shape would be more suitable in relation to the corrugation of the surface. In any event, the latter would be fairly close to a parabola, and the calculations in this chapter are also approximately applicable to the shape optimizing the mode of extension of a corrugated surface.

but, in general, they will form a couple, which will tend to tilt the aerostat, the more strongly the greater the distance between them.

544. This couple can always be balanced by displacing the center of gravity of the aerostat (for instance, by moving the gondola to the right or left) or the center of the lift force (Fig. 42), but even so it is better that the couple be as close to zero as possible. Actually, when the center of thrust lies above the center of pressure of the air stream, the envelope should be made more convex on top (Fig. 11, bottom diagram). Note that even when the center of thrust and the center of wind pressure coincide, equilibrium is established only when the aerostat is in uniform horizontal motion or when the acceleration, whether positive or negative, is small.

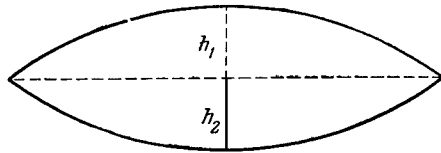

Fig. 57

Now if the propeller were suddenly to spin rapidly, in the absence of special countermeasures, the airship would start to "peck" [pitch] owing to the fact that the center of inertia of the ship does not normally coincide with the center of wind pressure. Another drawback of this approach to the problem of bringing the centers of pressure into coincidence is that, as the shape of the envelope undergoes distortion, the resistance to its motion increases, and it becomes more difficult to design a suitable envelope. In a good aerostat system, where the center of pressure on the propeller is transmitted to the longitudinal axis, there is no need for such distortion (Fig. 34).

Mean Position of Center of Pressure of Air Stream
on Envelope. Length of the Girders

545. When the envelope is inflated to half capacity, the length of the longitudinal girders must be such that the longitudinal axis cuts the envelope, or the vertical distance between the highest and lowest points of the envelope, exactly in two. Then the center of pressure of the air stream will lie close to the axis.

546. For a parabolic aerostat (414), we have, approximately:

$$2s_1 = 2x_1 \left(1 + \frac{2}{3} \cdot \frac{h_1^2}{x_1^2} \right),$$

where $2s_1$ is the length of the upper arc, and $2x_1$ is the length of the axis. For the lower arc we have:

$$2s_2 = 2x_1 \left(1 + \frac{2}{3} \cdot \frac{h_2^2}{x_1^2} \right).$$

From a drawing of the principal cross section of the envelope inflated to half capacity (see, e.g., Fig. 16), we can find the maximum height of the envelope. Dividing this by two, we find h_2 .

Now subtracting the depth of the furrow (or longitudinal depression in the top of the envelope), we find h_1 . Now, once the length of the aerostat, or the length $2x_1$ of the axis, is known, we have all the

information we need in order to determine the arc lengths $2s_1$ and $2s_2$ from the available formulas.

Equation of the Longitudinal Girders of a
Deflated Metal Aerostat

547. If the parabolic bag is deflated and flat, then, on the basis of the last two formulas, we will have:

$$s_1 = x_2 \left(1 + \frac{2}{3} \cdot \frac{h_3^2}{x_2^2} \right)$$

and

$$s_2 = x_2 \left(1 + \frac{2}{3} \cdot \frac{h_4^2}{x_2^2} \right),$$

since the lengths s_1 and s_2 suffer no change in the deflation process; only the rises h_3 and h_4 and the axis $2x_2$ change. These three quantities are unknown and have to be determined. However, we have available a third equation:

548. $p = 2 (h_3 + h_4),$

since the perimeter p of the center cross section through the envelope will be the same before and after deflation.

549. From equations (547), we find on subtracting:

$$x_2 = \frac{2}{3} \cdot \frac{h_4^2 - h_3^2}{s_2 - s_1},$$

550. Now, eliminating x_2 from the first formula in (547), we have

$$s_1 = \frac{2}{3} \cdot \frac{p}{2} \cdot \frac{h_4 - h_3}{s_2 - s_1} + \frac{2}{p} \cdot \frac{h_3^2 (s_3 - s_1)}{h_4 - h_3},$$

since, on the basis of (548):

$$h_4^2 - h_3^2 = (h_4 + h_3) (h_4 - h_3) = \frac{p}{2} (h_4 - h_3).$$

551. With the aid of formula (548), we now eliminate h_4 from this equation; we then find

$$s_1 = \frac{p}{6} \cdot \frac{(p - 4h_3)}{(s_2 - s_1)} + \frac{4}{p} \cdot \frac{h_3^2 (s_2 - s_1)}{(p - 4h_3)}.$$

Hence, for h_3 or the upper rise of the deflated bag, we get

$$h_3 = \frac{p[p^2 - 3s_1(s_2 - s_1)]}{2[2p^2 + (s_2 - s_1)^2]} \cdot \left\{ \pm \sqrt{1 - \frac{[p^2 - 6s_1(s_2 - s_1)][2p^2 + (s_2 - s_1)^2]}{2[p^2 - 3s_1(s_2 - s_1)]^2}} \right\};$$

we obtain h_4 , i.e., the lower rise, by substituting s_2 for s_1 , and vice versa.

552. Since $(s_2 - s_1)^2$ is a quantity of the second order of smallness, on discarding it we get

$$h_3 = \frac{p}{4} \left[1 - 3 \frac{s_1}{p} \left(\frac{s_2 - s_1}{p} \right) \right] \cdot \left\{ 1 \pm \sqrt{1 - \frac{\left[1 - 6 \cdot \frac{s_1}{p} \left(\frac{s_2 - s_1}{p} \right) \right]}{\left[1 - 3 \cdot \frac{s_1}{p} \left(\frac{s_2 - s_1}{p} \right) \right]^2}} \right\}$$

in place of the last formula.

553. Now, denoting $\frac{3s_1}{p} \left(\frac{s_2 - s_1}{p} \right)$ by k , we find

$$h_3 = \frac{p}{4} (1 - k) \left[1 \pm \sqrt{1 - \frac{1 - 2k}{(1 - k)^2}} \right];$$

but since $(1 - k)^2 = 1 - 2k + k^2$ and since (k^2) is a small quantity of second order, we discard it and obtain

$$h_3 = \frac{p}{4} (1 - k) = \frac{p}{4} \left\{ 1 - 3 \cdot \frac{s_1}{p} \left(\frac{s_2 - s_1}{p} \right) \right\}.$$

554. Replacing s_1 by s_2 , and vice versa, we find

$$h_4 = \frac{p}{4} \left\{ 1 + 3 \cdot \frac{s_2}{p} \left(\frac{s_2 - s_1}{p} \right) \right\}.$$

555. In the last two equations, we find the value of $s_2 - s_1$ from (549) as:

$$s_2 - s_1 = \frac{2}{3} \cdot \frac{h_2^2 - h_1^2}{x_1}.$$

The arcs s_2 and s_1 are known from equations (546); the perimeter p may be determined from Fig. 16 or from the corresponding table. The rest is known (Fig. 57).

556. Once the rises h_3 and h_4 are known, we can also write the equation of the deflated envelope or, more accurately, the equation of the top and bottom girders, viz.:

$$y = h_3 \left(1 - \frac{x^2}{x_1^2}\right) \quad \text{and} \quad y = h_4 \left(1 - \frac{x^2}{x_2^2}\right),$$

where x and y are coordinates, and $2x_2$ is a new axis only slightly shorter than the previous $2x_1$. It can be determined readily from equation (547), from which we find

$$557. \quad x_2 = \sqrt{s_1^2 - \frac{2}{3} \cdot h_3^2}.$$

Length of Stiffening Hoops and Inclination of
Girders to Longitudinal Axis

558. Once we have equation (556) for the girders, we also have the length of the stiffening hoops. In the first equation, y denotes the length of a hoop of the deflated envelope from the axis to the upper girder, and in the second equation it has the same significance in relation to the bottom girder; x is the distance from the center of the envelope to the hoop. The length from one edge of the envelope to the other, or the length of half a hoop, will be [cf. (556)]

$$(h_3 + h_4) \left(1 - \frac{x^2}{x_2^2}\right) = \pi y_1 \left(1 - \frac{x^2}{x_2^2}\right) = \pi y = \frac{p}{2} \left(1 - \frac{x^2}{x_2^2}\right),$$

where y and y_1 are the radii of the envelopes inflated to form a

surface of revolution; p is the perimeter of the center cross section; x_2 is the length of the semi-axis of the deflated envelope, close to x_1 and defined by formula (557).

559. The inclination of the longitudinal girders to the axis may be checked from the value of the derivatives (556):

$$\frac{dy}{dx} = -\frac{2h_3 x}{x_2^2} \quad \text{and} \quad \frac{dy}{dx} = -\frac{2h_4 x}{x_2^2}.$$

Cross-Sectional Area of Longitudinal Girders and
Their Weight in the Case of a Variable Cross
Section (Strength of Envelope Neglected;
Gravity and Lift Force Moments Equal)

560. Chapters IX and X contain all the data needed to solve the problem of the cross-sectional area of the longitudinal girders for a given material, with the strength of the envelope neglected. We shall now consider the simplest case (469), where the gravity moment and the moment of the lift force are equal at every cross section through the aerostat, so that, being opposed, they cancel each other out. Then only the gas pressure will act on the girders.

On the basis of formulas (456) and (468), we find that the top girders will be acted upon by a force

$$\pi a y^2 \left(y_3 + y_1 + \frac{1}{4} y \right),$$

and the bottom girders by a force

$$\pi a y^2 \left(y_3 + y_1 - \frac{1}{4} y \right).$$

561. Do not forget that the longitudinal tension acting on the corrugated surface will have an important effect on the stresses in the girders since it acts in the opposite direction and will therefore tend to reduce the girder stresses. The greater this longitudinal tension, the smaller the force tending to stretch the girders. In these calculations we shall neglect the elasticity of the corrugated surface of the envelope, and assume the force exerted by the gases acts exclusively on the longitudinal girders.

562. The ultimate strength of the material will be denoted by K , and the permissible stress by K_d . The factor of safety will then be $\frac{K}{K_d} = n$. Now, for the purpose of determining the cross-sectional area of the top and bottom girders we have the formulas

$$\pi a y^2 \left(y_3 + y_1 + \frac{1}{4} y \right) \cdot \frac{n}{K}$$

and

$$\pi a y^2 \left(y_3 + y_1 - \frac{1}{4} y \right) \cdot \frac{n}{K}.$$

563. If we put $y = y_1$, we obtain the maximum areas of the center cross section through the girders; to be precise:

$$\pi a y_1^2 \left(y_3 + \frac{5}{4} y_1 \right) \cdot \frac{n}{K} \quad \text{and} \quad \pi a y_1^2 \left(y_3 + \frac{3}{4} y_1 \right) \cdot \frac{n}{K}.$$

564. The weight of top girders of variable cross section will be expressed by the integral

$$\pi \gamma_g a \cdot \frac{n}{K} \int y^2 (y_3 + y_1 + \frac{1}{4} y) ds.$$

And the weight of the bottom girders by

$$\pi \gamma_g a \cdot \frac{n}{K} \int y^2 (y_3 + y_1 - \frac{1}{4} y) ds,$$

where γ_g is the density of the material constituting the girder.

565. It is even simpler to determine the weight of the upper and lower girders at the same time. The sum of the areas of the top and bottom cross sections will be [cf. (562)]

$$2\pi a y^2 (y_2 + y_1) \cdot \frac{n}{K}.$$

Clearly, the thickness and width of the girders will be proportional, on the average, to y or to the diameter $2y$ of the cross section for the same airship.

566. The weight of all the longitudinal girders is approximately*

*The error due to the fact that dx is taken instead of ds will reduce

$$2\pi\gamma_g a (y_3 + y_1) \cdot \frac{n}{K} \int y^2 dx.$$

Since $y = y_1 \left(1 - \frac{x^2}{x_1^2}\right)$, we have, on integrating,

$$\int y^2 dx = y_1^2 x \left(1 - \frac{2}{3} \cdot \frac{x^2}{x_1^2} + \frac{x^4}{5x_1^4}\right).$$

But if $x = x_1$, then

$$\int y^2 dx = \frac{8}{15} y_1^2 \cdot x_1,$$

and the total weight of the girders will be

$$\frac{32}{15} \cdot \frac{n}{K} \pi\gamma_g a (y_3 + y_1) y_1^2 x_1.$$

567. This means that the weight of the girders increases with the pressure y_3 at the lowest point of the envelope. The pressure y_3

the weight of the girders by less than $\frac{1}{3} \frac{y_1^2}{x_1^2}$, i.e., by a quite small fraction of the determined value.

varies constantly as the filling gas expands or contracts. The safety valve may be set in such a way, for instance, that the pressure y_3 at the lowest point can not exceed y_1 . At that pressure, even the center cross section will expand almost to a full circle, as we shall see later on from tables. But the valve may be set to an even lower pressure, say $1/2 y_1$, so that the cross section is still not very full.

If we put $y_3 = y_1$, the cross-sectional area will be (cf. the above formulas):

for the top girders

$$\pi a y^2 (2y_1 + 1/4 y) \cdot \frac{n}{K},$$

and for the bottom girders

$$\pi a y^2 (2y_1 - 1/4 y) \cdot \frac{n}{K}.$$

568. The maximum center section will be

$$9/4 \pi a y_1^3 \cdot \frac{n}{K} \quad \text{and} \quad 7/4 \pi a y_1^3 \cdot \frac{n}{K}.$$

569. In general, the sum of the top and bottom cross sections will be

$$4\pi a y_1 \cdot \frac{n}{K} \cdot y^2,$$

and the maximum of this sum will be

$$570. \quad 4\pi a \cdot \frac{n}{K} \cdot y_1^3.$$

571. The total weight of the girders is found as [cf. (566)]:

$$\frac{64}{15} \cdot \frac{n}{K} \cdot \gamma_g \text{ap} y_1^3 x_1.$$

572. Putting $\frac{x_1}{y_1} = \lambda$, we now find

$$\frac{64}{15} \cdot \frac{n}{K} \cdot \gamma_g \text{ap} \lambda y_1^4,$$

i.e., for a constant aspect ratio λ of the envelope, the weight of the girders will be proportional to the fourth power of the dimension y_1 of the airship, while the lift force will increase in proportion to the third power. This clearly indicates that the size of the aerostat is limited.

Weight of Longitudinal Girders in the Case
of a Constant Cross Section

573. In view of the fact that in certain circumstances the aerostat may tilt, so that the pressure at the higher end increases drastically, while a catwalk, the weight of which cannot be balanced by the gas pressure, is slung beneath the bottom girders, we would do well to assume that the girder cross section is constant, irrespective of how close parts of the girder may be to the ends of the envelope and the corresponding maximum gas pressure. Then, on the basis of formulas (563), we arrive at the following expression for the total weight of all the girders:

$$\pi \gamma_g a y_1^2 \frac{n}{K} \left\{ (y_3 + \frac{5}{4} y_1) \cdot 2s_1 + (y_3 + \frac{3}{4} y_1) \cdot 2s_2 \right\},$$

where $(2s_1 + 2s_2)$ is the perimeter of the principal longitudinal section through the envelope.

574. We may assume approximately, cf. (414):

$$s_1 = s_2 = x_1 \left(1 + \frac{2}{3} \cdot \frac{y_1^2}{x_1^2} \right);$$

in which case the weight of the girders will be

$$4\pi\gamma_g a y_1^2 \frac{n}{K} (y_3 + y_1) \cdot x_1 \left(1 + \frac{2}{3} \cdot \frac{y_1^2}{x_1^2}\right).$$

575. Still less accurately:

$$4\pi\gamma_g a \cdot \frac{n}{K} \cdot x_1 y_1^2 (y_3 + y_1).$$

576. Putting $y_3 = y_1$, we have

$$8\pi \cdot \gamma_g a \cdot \frac{n}{K} \cdot x_1 y_1^3.$$

577. Formulas (575) and (566) provide us with an opportunity to find out by how many times the weight of girders of constant cross section will exceed the weight of girders of variable thickness. By dividing the first formula by the second, we obtain then $1\frac{5}{8}$ or $1\frac{7}{8}$. Clearly, then, the weight of the girders of variable cross section is almost half that of the girders of constant cross section.

Weight of Stiffening Hoops of Constant Cross Section
(Strength of Envelope Neglected)

578. If we assume that the corrugated aerostat envelope is very thin and that its stiffness can be neglected in our calculations, the longitudinal gas pressure must be resisted exclusively by the hoops. We shall proceed to determine the weight of hoops of constant thickness for this case.

From Chapter X [(486) ff.], we draw the following conclusions concerning the transverse stresses on the envelope.

- a) The maximum stress at any cross section occurs at the highest point of that cross section.
- b) In the principal cross section, the stresses are greater than in any other section.
- c) We may conclude from the first two points that the maximum transverse stresses in a given envelope occur at the highest point of the center cross section.

This stress is expressed exactly by the formula

$$t_z = \frac{a}{2} (h - h_1) (h + h_1 + 2y_3)$$

[cf. Fig. 15 and formulas (498)].

579. Here the letter h denotes the height of the envelope, or the vertical distance between the highest and lowest points of the envelope (Fig. 15).

580. Assuming that this is the maximum stress for all the hoops, we must also assume that their cross-sectional area is the same, namely:

$$\frac{a}{2} (h - h_1) (h + h_1 + 2y_3) \cdot \frac{n}{K}.$$

Here the stress is calculated per unit width of a strip of the cross section. The formula therefore expresses the cross-sectional area of hoops spaced unit distance apart. Clearly, the total weight

of the hoops will be independent of how closely they are spaced over the length of the envelope, since the cross-sectional area of each hoop will diminish proportionately as the number of hoops stiffening the envelope increases.

581. If we take a transverse strip of the envelope of unit width and unit length, then the weight of the hoop per unit area of the envelope may be expressed [cf. (580)] as:

$$\gamma_0 \cdot \frac{a}{2} (h - h_1) (h + h_1 + 2y_3) \cdot \frac{n}{K},$$

where γ_0 is the density of the material constituting the hoops.

582. Obviously, the weight of all the hoops may be expressed as the product of this quantity and the total surface area $2F_1$ of the envelope [cf. (386)]; thus, we have

$$\frac{4}{3} \pi \gamma_0 a (h - h_1) (h + h_1 + 2y_3) y_1 x_1 \left(1 + \frac{2}{5} \cdot \frac{y_1^2}{x_1^2} \right) \cdot \frac{n}{K}.$$

583. This formula expresses with a high degree of accuracy the weight of hoops of constant cross section. But the weight of the hoops may be expressed in still another way, though less exactly.

The average pressure per unit area of any cross section is $(y_3 + y_1) a$ [cf. (486)]. The pressure on the hoop per unit width at the center cross section of the envelope is $(y_3 + y_1) y_1$. The cross-sectional area is

$$a y_1 (y_3 + y_1) \cdot \frac{n}{K}.$$

584. Accordingly, the weight of the complete set of hoops (582) will be:

$$\frac{8}{2} \pi \gamma_0 a x_1 y_1^2 (y_3 + y_1) \left(1 + \frac{2}{5} \cdot \frac{y_1^2}{x_1^2}\right) \cdot \frac{n}{K}.$$

585. Putting $y_3 = y_1$ and $\frac{x_1}{y_1} = \lambda$, we find

$$\frac{16}{3} \pi \gamma_0 a \lambda y_1^4 \left(1 + \frac{2}{5\lambda^2}\right) \cdot \frac{n}{K}.$$

Hence we see that the weight of the hoops increases in proportion to the fourth power of the dimension y_1 of the airship (if its shape varies in the same way).

The Weight of Stiffening Hoops of Variable Cross Section (Strength of Envelope Neglected)

586. In view of the fact that the envelope offers excellent resistance to the pressure exerted by the gas in the transverse direction -- in the direction of the hoops, we may also assume that the cross section of the hoops varies in accordance with the true gas pressure.

The average pressure [cf. (486) and later] per unit surface area of any cross section is a $(y_3 + y_1)$; the pressure acting on a hoop per unit width will be a $(y_3 + y_1) 2y$; the average tension on

this hoop at top or bottom will be $a (y_3 + y_1) y$. The cross-sectional area will be

$$a (y_3 + y_1) y \cdot \frac{n}{K}.$$

587. The differential of the total weight of the hoops will be approximately:

$$a (y_3 + y_1) y \cdot \frac{n}{K} \cdot 2\pi\gamma_0 dx.$$

Consequently, the weight of the hoops will be

$$2\pi\gamma_0 a \cdot \frac{n}{K} (y_3 + y_1) \cdot \int y^2 dx.$$

588. We have arrived at a formula identical with that (566) for the weight of the girders. Clearly, the total weight of the hoops may be expressed by exactly the same formula as used for the weight of the girders (566), i.e.,

$$\frac{32}{15} \cdot \frac{n}{K} \pi\gamma_0 a (y_3 + y_1) y_1^2 x_1.$$

If $y_3 = y_1$ and $\frac{x_1}{y_1} = \lambda$, we have

$$\frac{64}{15} \cdot \frac{n}{K} \cdot \pi \gamma_0 a \lambda y_1^4.$$

589. I have assumed here that the stress on a given hoop is constant and equal to the average stress, but in fact the maximum stress is only slightly different from the minimum stress. From formula (468), we find this stress ratio for $y_3 = y_1$:

$$\left(1 + \frac{y}{8y_1}\right) \cdot \left(1 - \frac{y}{8y_1}\right).$$

Clearly, the smaller the radius y of the cross section, the closer this ratio will be to unity. For the principal cross section, the ratio will be greatest, but even here it only amounts to $9/7$. Accordingly, the maximum stress will be only $1/7$ greater than the average stress, and the minimum stress will be smaller by the same factor. Accordingly, the top of each hoop may be made $1/7$ thicker than the bottom.

590. However, in view of the use of simplified formulas for the gas pressure in calculating the hoop stresses, the true stress will be at least $5/4$ times greater than indicated here, so that there will be no particular need to make each hoop of variable thickness.

Formulas (488) and (498) serve as a means of checking this.

591. Formulas (584) and (588) enable us to determine by how many times the weight of hoops of constant cross section will exceed the weight of hoops of variable thickness. Neglecting the factor

$\left(1 + \frac{2}{3} \cdot \frac{y_1^2}{x_1^2}\right)$ in the first formula, since it is close to unity, and

dividing through by the second formula, we arrive at a figure of $5/4$. Consequently, using a constant cross section increases the weight of the hoops by only $1/4$ the weight of the hoops of variable cross section.

Strength of Envelope: Transverse and Longitudinal
Strength. Weight of Envelope

592. The ultimate transverse strength of the envelope over an interval dx is approximately equal to $K \cdot \delta_{env} \cdot dx$; the average tension on the envelope due to the gas pressure may be expressed (586) as:

$$a (y_3 + y_1) y dx.$$

The ratio of the resistance of the material to the applied force will be

$$\frac{\delta_{env} K}{a (y_3 + y_1) y} = n.$$

Clearly, then, the factor n is inversely proportional to the diameter y of the cross section. Hence, when the factor n is adequate at the center cross section, it will a fortiori be adequate at smaller cross sections (given, of course, an envelope of constant thickness δ_{env}).

593. From this last formula, we have

$$\delta_{env} = a (y_3 + y_1) y \cdot \frac{n}{K},$$

i.e., in the case of a variable envelope cross section the envelope thickness will be directly proportional to the diameter $2y$ of the cross section of a given airship.

594. If we assume the envelope thickness to be constant, then we must put $y = y_1$ in the formula: we then find:

$$\delta_{\text{env}} = a (y_3 + y_1) y_1 \cdot \frac{n}{K}.$$

595. Making the further assumption that $y_3 = y_1$, we have:

$$\delta_{\text{env}} = 2ay_1^2 \cdot \frac{n}{K},$$

i.e., the thickness of the aerostat envelope increases in proportion to the square of its vertical dimension y_1 .

596. The weight of an envelope of constant thickness, with an adequate safety factor n in the transverse direction, is obtained when the surface area of the envelope is multiplied by the thickness δ_{env} and the density γ_{env} .

Assuming the envelope to have the shape of a surface of revolution, we find the total surface area from the formula (386):

$$2F_1 = \frac{8}{3} \pi y_1 x_1 \left(1 + \frac{2}{5} \cdot \frac{y_1^2}{x_1^2} \right).$$

But the inflated envelope is covered with corrugations, so that we must introduce a correction factor into formula (386); moreover, part of the envelope surface overlaps at the seams, while, on the other hand, part is replaced by the fairly broad stiffening hoops. We can take all these corrections into account by means of a single multiplier η , which is only slightly greater than unity and may even be equal to unity.

In fact, on the basis of the preceding formula and formula (594), the weight of the envelope will be found to be:

$$\frac{8}{3} \pi \eta \gamma_{\text{env}} a x_1 y_1^2 \cdot (y_3 + y_1) \left(1 + \frac{2}{5} \cdot \frac{y_1^2}{x_1^2} \right) \frac{n}{K} .$$

597. Putting $y_3 = y_1$ and $\frac{x_1}{y_1} = \lambda$, we find

$$\frac{16}{3} \pi \eta \gamma_{\text{env}} a \lambda y_1^4 \left(1 + \frac{2}{5 \cdot \lambda^2} \right) \cdot \frac{n}{K} .$$

Accordingly, the weight of an envelope of constant thickness, like that of the hoops, is proportional to the fourth power of the dimensions of an airship, assuming the shape varies in a similar manner.

Moreover, on comparing formulas (596) and (584), we see that the weight of the hoops and the weight of the envelope are almost the same, since the ratio η is very close to unity.

598. From the standpoint of adequate transverse strength, the weight of an envelope of variable thickness is clearly expressed by the same formula as the weight of hoops of variable cross section (588) or the weight of girders of variable thickness (584).

We must now consider the question: will an envelope designed

for adequate transverse resistance be sufficiently strong in the longitudinal direction as well?

599. If no folds of any kind were formed and if the envelope were smooth in the longitudinal direction, its strength in that direction would not be difficult to calculate. In fact, in that case the ultimate strength of any given cross section in longitudinal tension would be

$$2\pi y \delta_{env} K.$$

The gas pressure on that cross section would be:

$$a (y_3 + y_1) (\pi y^2).$$

The average safety factor for the cross section would therefore be:

$$n = \frac{2\delta_{env} K}{a (y_3 + y_1) y},$$

i.e., twice as great in the longitudinal as in the transverse direction [cf. (592)].

However, because of folds in the longitudinal direction, the strength in that direction will depend not only on the envelope thickness and the strength of the material constituting the envelope, but also on the shape of the corrugations, their amplitude, slope, and in general on the degree of tension, which will in turn depend on the extent to which the shape of the cross section departs from the mathematical curve defined in Chapter VI under the assumption of

near-zero longitudinal tension. This is a highly involved question and the formulas (332) to (341) in Chapter VII will prove very useful in clarifying it.

Nevertheless it seems to me that this tension will not be less than half that for a smooth envelope, under favorable conditions, so that the strength in the longitudinal direction will not be less than the strength in the transverse direction.

600. We can now summarize our calculations on the weight of the structural components of the aerostat and the envelope.

a) The weight of an envelope of constant thickness is expressed by the same formula as used for the weight of hoops of constant cross section (584) and (596).

b) The same applies to the weight of an envelope and hoops of variable cross section (606) with adequate strength.

c) These weights ("b," above) are likewise severally equal to the weight of girders of variable thickness (583).

d) The weight of hoops or the weight of an envelope of constant thickness is $1\frac{1}{4}$ times greater than the corresponding weight for variable thickness.

e) The weight of girders with a constant cross-sectional area is $1\frac{7}{8}$ times greater than the corresponding weight when the thickness diminishes toward the ends of the envelope.

f) An envelope whose strength is satisfactory in the transverse direction will also, under favorable conditions, be sufficiently strong in the longitudinal direction as well.

g) The weight of the envelope and of the structural components of an aerostat whose shape varies in a similar manner will increase in proportion to the fourth power of the linear dimensions of the aerostat. But if the height of the envelope and its length increase disproportionately, the increase in weight will be proportional to the length $2x_1$ and the cube of the height $(2y_1)^3$, and will, in general, be proportional to $x_1 y_1^3$.

h) Denoting the weight of hoops of variable thickness by G and neglecting the strength of the metal envelope, we find that the

weight of the hoops of variable cross section plus the weight of girders of variable cross section is $2G$.

i) The weight of hoops of constant cross section and girders of constant cross section will be:

$$\frac{5}{4} G + \frac{15}{8} G = \frac{25}{8} G,$$

(i.e., $1\frac{9}{16}$ times greater than before "h").

j) The weight of hoops of constant cross section and girders of variable cross section will be:

$$\frac{5}{4} G + G = \frac{9}{4} G,$$

(i.e., only $\frac{9}{8}$ times greater than in case "h").

k) By eliminating the massive parts or reducing their weight to the point where it can be safely neglected, we find that the weight of an envelope of variable thickness satisfying the requirement of adequate strength will be G , and the weight of an envelope of constant thickness will be $\frac{5}{4} G$.

l) The weight of an envelope of cross section and girders of variable cross section (without hoops) will be

$$\frac{5}{4} G + G = \frac{9}{4} G = 2\frac{1}{4} G.$$

m) The weight of an envelope of constant cross section with hoops of constant cross section and girders of variable cross section will be:

$$5/4 G + 5/4 G + G = 3 1/2 G.$$

Of course, the strength of an envelope of this type will be twice that of an envelope corresponding to case "h"; moreover, this type of aerostat will be safe to operate even if heavily tilted. Therefore, reducing the weight of the envelope and the structural components by half, we obtain as the sum of the weights only

$$7/4 G = 1 3/4 G.$$

n) Thus, dropping G , we obtain the following sequence of coefficients expressing the weight of the components and the envelope:

$$1; 2; 3 1/8; 2 1/4; 1 1/4; 2 1/4; 3 1/2; 1 3/4.$$

Weight of Envelope of Constant Thickness
when its Strength is Neglected

601. In this case, the weight of the envelope may be expressed by the formula

$$2F\eta_{env} \cdot \delta_{env},$$

where $2F$ is the surface area of the inflated envelope determined from formula (386):

$$2F = 8/3 \pi y_1 x_1 \left(1 + \frac{2}{5} \cdot \frac{y_1^2}{x_1^2} \right).$$

The remaining quantities are, respectively: the area coefficient η , slightly greater than unity, the density γ_{env} of the material, and the thickness δ_{env} of the material.

Weight of Cylindrical Longitudinal Strips Forming the
Top and Bottom of the Envelope for the
Case of Constant Width

602. The sum of the weights of two almost identical smooth rectangular longitudinal strips will be:

$$[Q_s =] \gamma_s (2s_1 + 2s_2) b_s \delta_s,$$

where γ_s is the density of the material constituting the strip; s_1 and s_2 are the lengths of the strips; b_s is the width of the strip; δ_s its thickness.

603. We may assume that approximately $2s_1 + 2s_2 = 4x_1$, so that the weight of the strip will be $4\gamma_s x_1 b_s \delta_s$.

If the width of the strip is assumed equal to the width of the gondola and proportional to the vertical dimensions of the aerostat $2y_1$, i.e., $b_s = y_1/m$, then the weight of the strips may be expressed by the formula

$$\frac{4}{m} \cdot \frac{x_1}{y_1} \cdot y_1^2 \gamma_s \delta_s = \frac{4}{m} \cdot x_1 y_1 \gamma_s \delta_s,$$

where $m = \text{const.}$

We may also assume the weight of the strips to be equal to a certain fraction of the weight of the envelope plus the hoops.

Weight of Main Vertical Rod-Chains

604. The weight of the gondola and its entire contents usually comprises only half the total lift force of the aerostat. Therefore, assuming that the chains and rods are vertical and that the tension on these members is half the total lift force, we can construct the equation:

$$\frac{1}{2} \cdot aU = \frac{K}{n} F_{\text{rod}}.$$

Here a is the difference between the densities of the external and internal gases; U is the gas volume or the volume of the gas cell; K is the ultimate strength of the chain material; n is the safety factor assigned to the chains; F_{rod} is the sum of the areas

of normal cross sections through the rods, chains, or cables.

605. Using γ_{rod} to denote the density of the material, and l_{rod} to denote the greatest vertical distance between the highest point of the envelope and the floor of the gondola, we find that the weight of these rods and supports cannot exceed $\gamma_{\text{rod}} F_{\text{rod}} l_{\text{rod}}$. Including the parabolic chains in the category of vertical chains, we

may assume, on the basis of this and previous formulas, that the total weight will be roughly:

$$[Q_{\text{rod}} =] \frac{n}{2K} aU \gamma_{\text{rod}} t_{\text{rod}}.$$

Weight of Passengers and Motors

606. Let the weight of the passengers be a certain fraction k_p of the lift force aU ; then their weight may be expressed by the formula

$$[Q_p =] k_p aU.$$

Now let the weight of the motors also be a certain fraction k_m of the lift force; their weight will then be

$$[Q_m =] k_m aU.$$

Weight of Gondola, Control Surfaces, and Propellers

607. Since the weight of the gondola is proportional to the weight of the passengers, motors, etc., i.e., proportional to the lift force, we may assume the weight of the gondola to be

$$[Q_g =] k_g aU,$$

where k_g is a certain fraction of the lift force assigned to the gondola.

608. Assuming the aerostat to have a constant shape, we may make the further assumption, as in naval architecture, that the surface of the control surfaces and propellers separately will constitute a certain fraction of the envelope cross section or, in other words, that their surface area will be proportional to the surface area of the ship.

If the speed of an aerostat varying in this manner must be constant, then the pressure on the control surfaces and propeller will also be proportional to the surface area of the ship. The moment of this pressure will then be proportional to the volume. If the average thickness of the control surfaces, etc., is proportional to the size of the ship, then the moment of resistance of these parts, just like the moment of the pressure exerted on them by the air stream, will be proportional to the cube of the linear dimensions of the ship or its volume. Thus, the moment of resistance will correspond to the moment of pressure, so that the weight of the control surfaces, propellers, etc., will be proportional to the volume and may be expressed by the formula

$$[Q_y =] k_y aU,$$

where k_y is a certain fraction of the lift force assigned to the control surfaces.

609. We have assumed that the thrust developed by the motors is proportional to the lift force of the ship, i.e., proportional to the cube of the ship's dimensions. Clearly, then, the pressure on the control surfaces and propellers will increase more rapidly than the square of the ship's dimensions or its surface area. Consequently, under conditions such that the speed increases with the size of the ship, the weight of the control surfaces must increase faster than the

cube of its dimensions. In order to avoid this, it will be necessary for the control surfaces to be made of stronger and lighter material, of aluminum or steel tubes for instance; finally, several propellers may be required. In general, by exercising a certain amount of ingenuity it should be possible to preserve the situation in which the weight of the control surfaces and propellers is proportional to the lift force.

Black Inner Tube for Heating the Light Gas

610. A black metal tube placed inside the envelope (Fig. 1) for the purpose of heating the hydrogen should be made of such material and so designed as not to burn through and to sustain a temperature difference between the external air and the internal gas, which is the greater the larger the ship. The average thickness of the sheet metal of which the tube is made may be assumed to be constant or to increase only slightly with the size of the ship; the surface area of the tube may be assumed to be proportional to the surface area or, at least, to the volume of the aerostat. Clearly, then, the weight of the tubes can not increase faster than the lift force of the ship, so that we may generously assume for the weight of the heating tubes:

$$[Q_{\text{tube}} =] k_{\text{tube}} aU.$$

Of course, the thickness of the material forming a given tube must correspond with the temperature of its parts.

At the point where the hot combustion products are first admitted, the tube can be made heavier, but further along the thickness can be reduced.

611. We still have the problem of determining the weight of the couplings, valves, sheathing for the gondola, regulators, pulleys, anchors, catwalk, passengers seats, and of a host of fittings, mechanisms, and miscellaneous items of comfort and necessity. The weight

of the fuel has still to be taken into account in the calculations, bearing in mind the gas motors that require a supply of gas from the aerostat envelope.

Suppose that the weight of all the items not yet taken into account in the calculations is proportional to the total lift force; then this weight will be

$$Q_{\text{misc}} = k_{\text{misc}} aU,$$

where k_{misc} is some fraction of the lift force corresponding to the miscellaneous equipment and supplies.

612. The term U , i.e., the volume of the light gas, appears in the preceding formulas. From (389), we know that

$$2U_1 = 16/15 \pi r_1^2 x_1.$$

But, on the one hand, this is the volume of an aerostat inflated to the shape of a body of revolution, i.e., it is extremely large; while, on the other hand, it is small, since it must be increased by the intermediate elongated cylinder (Figs. 1 and 3).

In general, in view of the fact that the volume of the additional cylinder is proportional to the volume of the aerostat, we may assume for the total volume

$$U = 2U_1 k_v = 16/15 k_v \pi r_1^2 x_1,$$

where k_v is close to unity.

XIII. CALCULATION OF THE HEIGHT OF THE SHELL OF A BALLOON

A few preliminary words on the significance of the dimensions of a balloon (aerostat) are not out of place here.

The larger the dimensions, the more solid the construction of the metal shell and the more under control it is. A dirigible needs to be of large size for the gain from air support to exceed that from sea support. Even Giffard (1825-1882) understood very well the importance of large dimensions. Although he was a practical worker who spent millions on his steam engines, pumps, and balloons, he

planned to build a balloon of displacement $220\,000\text{ m}^3$.

He is not to be considered ignorant or a dreamer in this matter;

it was not by luck he made an anchored balloon of $25\,000\text{ m}^3$. He was interested in air flight from his youth; his guided balloons are known to all and constituted an epoch in aeronautics. Blindness and death have taken this ingenious man from us; he left all his estate to the poor of Paris and to learned societies to continue his work on guided balloons. What might have been if this genius had arisen and had used for his plans the present-day power of technology, our present Levasseur engines, which give something like a horsepower per kilogram weight! His planned balloon had a volume over twice that of my metal one designed for 200 passengers.

So we should not be surprised at the large dimensions of the metal shells of aircraft; they will be even larger than he thought.

Small balloons are unsuitable not only in respect of material; they would have metal shells of inadequate strength.

However, they can act as a means of studying ways of making such shells; they will also serve as an intermediate step to the vast aircraft, just as a small and weak child grows into a useful worker.

613. We have available data for calculating the largest dimensions of the shell with respect to height. The principal basis for this is the weight of the shell and of its massive parts.

From (600) we see that this weight can vary greatly. The following are some cases of practical or theoretical significance. These will be used in deriving the equations defining the height.

a) A shell of variable thickness, but so designed as to sustain the lengthwise and transverse pressures of the gases and other

disruptive forces. We neglect the weight and resistance of the spars and struts.

We take the weight of the shell as G [see (600), which is also needed later].

b) The same, but of constant thickness, which is governed only by the size of the vessel. The weight is $5G/4$.

c) The same (shell of constant thickness for a given balloon); we neglect the resistance of the spars and struts, but the weight of these is proportional to the lift of the vessel, which means that their thickness in all directions is proportional to the dimensions of the vessel. The weight of the shell is then

$$5/4 G + aUk_{s,0}'$$

in which $k_{s,0}$ is the part of the lift all taken up by the spars and struts.

d) Longitudinal spars of variable thickness and shell of variable thickness share equally the resistance to lengthwise forces. There are no struts, which are replaced by the shell. The spars have half weight ($G/2$), the weight of the shell being normal ($5G/4$). Then the weight of shell and spars is

$$5/4 G + 1/2 G = 7/4 G.$$

e) The same, but the weight of the shell halved; but also struts of constant thickness and constant weight ($5G/8$). The weight of the shell with struts and spars is then

$$1/2 G + 5/8 G + 5/8 G = 7/4 G,$$

which is as before.

614. All these cases are applicable only to very large balloons, for which the shell is of adequate thickness. Small sizes of vessel cause the shell to be too thin and so are not practical.

Then we can assume a shell of constant thickness generally, for all sizes of vessel, large and small.

f) For small sizes it is sufficient to take the weight of spars and struts as proportional to the lift, from (613); this is

$$[Q_{s,0} =] aUk_{s,0}.$$

The weight of a shell is known from (601).

g) On the other hand, we can neglect the resistance of the shell for vessels of large size, the spars and struts providing the resistance to the disruptive forces. We take the cross-section of the spars as variable (as usual) and that of the struts as constant, so the weight is given by (600) as

$$G + \frac{5}{4} G = \frac{9}{4} G.$$

To this we must add the weight of the shell in accordance with (601). This formula also contains the weight of the length-wise mounting band, which may or may not be present (Figs. 1-7). Where the shell acts as a supporting material, we may put the weight

of this band as

$$[Q_t =] Gk_b,$$

in which k_b is the part (of course less than one) assigned to the band.

615. The weight A of the shell with struts, spars, and band b in cases a-g will be

$$a) A = G (1 + k_b),$$

$$b) A = G (5/4 + k_b),$$

$$c) A = G (5/4 + k_b) + aUk_{0,s}$$

$$d) A = G (7/4 + k_b),$$

$$e) A = G (7/4 + k_b),$$

$$f) A = aUk_{s,0} + \frac{8}{3} \pi y_1 x_1 \left(1 + \frac{2}{5} \cdot \frac{y_1^2}{x_1^2} \right) \eta_{\gamma_s} \delta_s$$

$$g) A = \frac{9}{4} G + \frac{8}{3} \pi y_1 x_1 \left(1 + \frac{2}{5} \cdot \frac{y_1^2}{x_1^2} \right) \eta_{\gamma_s} \delta_s.$$

616. The basis for deriving the equation defining the height of the shell is that the weight of all parts and loads is equal to the upthrust aU . This weight without the shell is given by (602-612) as

$$aU(k_{bp} + k_k + k_M + k_c + k_p + k_r + G \cdot k_{ch}).$$

Here the coefficients with subscripts represent the following: k_{bp} black pipe, k_k keel plus hold, k_M motors, k_c controls, k_p passengers, and k_r reserve.

617. Also, k_{ch} is the weight of the vertical principal rods or chains; this is known from (605), and if we put $t_{ch} = k_{t_1} y_1$, we have the weight as

$$Gk_{ch} = \frac{n}{K} \cdot aU y_1^k t_1 y_1,$$

which is proportional to the fourth power of the height y_1 of the balloon, because U is proportional to the cube of y_1 . This means that it is proportional to G , so k_{ch} is a constant coefficient representing a certain fraction of the weight G of a shell of variable thickness.

618. The general equation for the height of the shell on the above basis is

$$A + Gk_{ch} + aU(k_{bp} + k_k + k_M + K_c + k_p + k_k) = aU.$$

This states that the weight of the shell A with the principal rods Gk_{ch} and the balanced keel plus hold is equal to half the upthrust of the vessel after subtracting the weight of the light gas.

619. We do not propose to determine the weight of the keel and other parts of the vessel:

$$aU(k_{bp} + k_k + k_M + k_c + k_p + k_r).$$

My earlier work (e.g., "A simple study of an air vessel") shows that this weight is about half of the total upthrust of the vessel; on this basis we can simplify (618) to

$$A + Gk_{ch} = 1/2aU.$$

620. A is known from (613), and k_{ch} can be found from (617) as:

$$k_{ch} = \frac{n}{2KG} aUy_{ch} k_{t_1} y_1.$$

621. From this we must eliminate U and G ; G we find from (588) and (566) as

$$G = \frac{32}{15} \cdot \frac{n}{K} \cdot \pi \gamma_{ch} a \left(1 + \frac{y_3}{y_1}\right) \frac{y_3^3}{1} \frac{x}{1};$$

U is known from (612).
Then we have that

$$k_{ch} = \frac{k_t \cdot k_U}{4 \left(1 + \frac{y_3}{y_1}\right)}.$$

For instance, if

$$k_t = 3; \quad k_U = 1; \quad y_3 = y_1,$$

then

$$k_{ch} = \frac{3}{8},$$

i.e., the weight of the chains is about $1/3$ of the weight of a shell of variable thickness.

622. In cases a, b, d, and e we can put (619) as

$$G(k + k_{ch} + k_b) = \frac{1}{2} aU,$$

in which k is the constant coefficient in parentheses in (615); for instance, in case a

$$A = G(1 + k_b)$$

and so on.

We eliminate U and G , simplify, and determine y_1 or the over-all height $2y_1$ of the shell to get

$$y_1 = \frac{k \frac{K}{U n}}{4\gamma_s (k + k_{ch} + k_b) \left(1 + \frac{y_3}{y_1}\right)} .$$

623. This shows that the over-all height $2y_1$ of the shell is proportional to the strength K of the material and is inversely proportional to the safety factor n . It is also inversely pro-

portional to the density γ_s of the material, to the sum $(k_u + k_b + k_{cg})$ dependent [see (613)] on the design of shell, and to $(1 + y_1/y_3)$, which is dependent on the excess pressure y_1/y_3 of the gas at the lowest point in the shell.

624. Case a of (615), when the massive parts of the shell are so small as to have negligible weight, is of little practical importance. Then the dimensions are largest, other things being equal, so A or K is least.

Then putting $K = 60 \text{ kg/mm}^2$ in (621) and (622), with $n = 6$, $k_u = 1$, $k_b = 0$, $\gamma_s = 7.5$, $k = 1$, and $y_1/y_3 = 1$, we have $k_{ch} = 3/8$ and $y_1 = 121.2 \text{ m}$, so the shell has a height of 242.4 m, or somewhat less than the Eifel tower. But such dimensions are far from obligatory; for instance, the size is reduced by a factor 10 if the strength is increased by a factor 10, so the $2y_1$ of (622) will be 24 m.

625. In case b, which is very similar to the previous but has a shell of constant thickness (for a given vessel), we find for the same conditions that $y_1 = 102.6 \text{ m}$ or $2y_1 = 205.2 \text{ m}$.

626. Turning now to the more practical cases d and e of (613), we have

$$k = \frac{7}{4}; \quad y_1 = 78.4 \text{ m} \quad \text{and} \quad 2y_1 = 156.8 \text{ m}.$$

This is about half the height of the Eifel tower.

627. It is of interest to deduce the upthrust of such a giant, as well as the thickness of the lengthwise spars and that of the shell.

To do this, we use the upthrust given by (612):

$$aU = \frac{16}{15} \cdot k_U \pi y_1^2 x_1 a.$$

628. We put $k_U = 1.2$, $y_1 = 150$ m, $\pi = 22/7$, $x_1 = 7y_1$, and $a = 0.001$ to get $aU = 9900$ t. Not less than a tenth of this force may be devoted to passengers; allowing 100 kg for each, we obtain 9900 passengers.

629. Formula (562) expresses the sum of the cross-sectional areas of the spars in the midsection of the shell.

This cross-section will be half that of (613) for cases d and e, and for one spar half this. The area is X^2 , so the size of the spar is

$$X = \sqrt{\frac{\pi}{2} \cdot a y_1^2 (y_3 + y_1) \cdot \frac{n}{K}}.$$

630. The shell thickness providing a safety factor $n = 6$ in the transverse direction is on average given by (594) as

$$\delta_s = a (y_3 + y_1) y_1 \cdot \frac{n}{K}.$$

For case d, under the usual conditions and with $2y_1 = 150$ m, we have $\delta_s = 1.125$ mm, which is rather thicker than roofing iron (about three times).

631. Struts are assumed in e; their cross-sectional area

equals that of the shell, since this area (of shell or struts) is δl in the lengthwise section of a shell of length l . Assuming one strut per meter of lengthwise section and taking the struts as square, we have the side X of the square as

$$X = \sqrt{\delta_s} l.$$

With $\delta_s = 0.562$ mm and $l = 1000$ mm we have $X = 23.7$ mm.

The struts will be thicker if more widely spaced. The struts may be streamlined in cross-section, in which case they can increase the surface area and lift of the shell. For instance, an elongation of nine increases the lift by 7%, or nearly doubles the number of passengers.

632. From (604) we have

$$F_{ch} = \frac{aUn}{2K}.$$

This enables us to calculate the cross-section of the principal chains, which support the hold, namely $F_{ch} = 4950$ cm²

for cases d and e. If we assume that the chains take up half the length of the airship and are 5 m apart, we find for double rows

that there are about 200 chains each of cross-section 25 cm².

633. Equation (622) can be put in more general form if we assume that the shell and its massive parts take up some fraction other than half of the upthrust aU , this part being e :

$$e = 1 - (k_{bp} + k_k + k_M + k_c + k_p + k_r).$$

Then (622) is replaced by

$$G(k_{ch} + k_b) = eaU$$

and

$$y_1 = \frac{ek_U K}{2y_n(k_s + k_{ch} + k_b) \left(1 + \frac{y_3}{y_1}\right)}.$$

This last reveals the relation of $2y_1$ to weight e of the shell: the latter increases with y_1 .

634. An approximation to replace (621) is

$$k_{ch} = \frac{(1 - e)k_k k_U}{2 \left(1 + \frac{y_3}{y_1}\right)}.$$

This shows that the chain-weight coefficient decreases as

the relative weight e (shell plus massive parts) increases.

635. We start with the smallest sizes for our first construction of airship, of course. From (633) we see that y_1 decreases as the safety factor n increases, so we can construct not only giants but also small airships while gaining in safety factor. Assuming a given n , we deduce y_1 from (633), and then from (594) we calculate the thickness of the shell.

For cases a, b, and d we take the full calculated thickness δ ; for case e, half of it as given by (613).

636. We deduce n from (630) and then eliminate y_1 from the resulting formula by means of (633) to get

$$n = \frac{k_{jae}^2}{8\gamma_s \delta_s (k + k_{ch} + k_b)^2 \left(1 + \frac{y_1}{y}\right)} \cdot \frac{K}{\gamma_s}$$

If we assume that the breaking strength K is proportional to γ_s , as is true for some materials, we have K/γ_s constant, in which case the safety factor increases as γ_s and δ_s decrease.

637. For instance, if we were to replace iron by aluminum in any of the cases a-e and reduce the thickness of the shell by a factor 6, the safety factor would increase by a factor 18 (aluminum is 3 times lighter than iron).

The safety factor should, naturally, be increased, in view of the small thickness of the shell, but we should hardly increase the safety factor of the massive parts (struts, longitudinal spars, principal chains), for this is quite unproductive. For what reason should we increase, for example, the safety factor of the longitudinal spars 18 times sixfold, i.e., to 108?

These equations for the height of the shell are thus unsuitable for cases d and e if we wish to make an airship of the least size.

They are applicable, though, to cases a and b.

638. For example, for cases b (shell of constant thickness, weight of massive parts negligible) we have from (630) subject to the conditions of (625) that $\delta_s = 2$ mm; we have taken $2y_1$ as 200 m.

If now we replace iron by aluminum and reduce the thickness by a factor 10, the height is reduced by a factor 30 and so will be $2y_1 = 6.67$ m. The aluminum shell will be 0.2 mm thick, or 2-1/2 times less than the thickness of roofing iron.

639. If we leave the material as iron but reduce the thickness by a factor of slightly more than 13, we have $2y_1 = 15$ m and $\delta_s = 0.15$ mm.

This thickness of tinplate is used commercially; I have such material in sheets about 50 cm long and about 30 cm wide.

These sheets are very rigid, and I consider them to be a material suitable for constructing airships that are not playthings, although case b may mostly be of significance as an experiment, in which case the size could even be reduced to 2-3 m.

640. We eliminate n from (630) and (636) to find $\gamma \delta_s$, which we eliminate in turn from (636) and find n as

$$n = \frac{1}{2} \cdot \frac{K}{\gamma_s} \cdot \frac{ek_1}{y_1 \left(k + k_{ch} + k_b \right) \left(1 + \frac{\gamma_3}{\gamma_1} \right)}$$

Taking K/γ as roughly constant for constructional materials, we see that the safety factor increases as y_1 decreases; but excessive safety in the massive parts is unnecessary and unfavorable.

641. The k_{ch} of (634) is not dependent on n , γ , or δ_s , if we assume a single material and the same n for all parts of the shell.

642. Now we consider an aluminum airship of type e, i.e., with struts and lengthwise spars as in (613), and put $k_u = 1$, $a = 0.001$ (ton/m³), $k_{2b} = 0$, $\gamma_s = 2.5$, $A = 7/4$, $\delta_s = 0.2$ mm, $e = 0.5$, $K = 20$ kg/mm, $k_{1s} = 3$, and $y_3/y_1 = 1$; then from (633), (634), and (640)

$$k_{ch} = \frac{3}{8}; \quad y_1 = 8.5; \quad n = 55.4.$$

In spite of the thin shell and light material, $2y_1 = 17$ m, so the airship is hardly of small height; but the safety factor is enormous, and, although this may be desirable for the shell (in view of its thinness), it is in no way desirable for the massive parts, because weight economy is of particular value for a balloon.

643. Case c is one in which the shell is designed to sustain lengthwise and transverse forces but still has massive parts, whose resistance we neglect and whose weight we take as proportional to the upthrust.

The thickness of the spars and struts is, from (613), proportional to the dimensions of the balloon.

The equation defining y_1 is found, as in other cases, from (615), (617), (621), and (627).
We have

$$y_1 = \frac{(e - k_s)k_u K}{2\gamma_s \cdot n \left(\frac{5}{4} + k_{ch} + k_b \right) \left(1 + \frac{y_3}{y_1} \right)} ;$$

and k_{ch} we know from (621).

This equation is the most applicable to giant airships, for which the shell is reasonably thick and the massive parts are not of excessive weight or strength.

644. We put $k = 1$, $k_s = 0.05$, $K = 60 \text{ kg/mm}^2$, $k_b = 0$,
 $n = 6$, $c = 7.5$, $y_{ch} = \frac{y_s}{3}$, $t = 0.5$, and $k_t = 3$; then

$$k_{ch} = \frac{3}{8}; \quad y_s = 92.3 \text{ m}; \quad \delta_s = 1.9 \text{ mm}.$$

This k_s indicates that the spars and struts take up only $\frac{1}{20}$ of the upthrust aU of the vessel, or $\frac{1}{10}$ of the weight of the shell with its massive attachments and chains.

645. Clearly, larger k_s imply smaller y_s ; but then the shell will be thinner [see (594) or (630)]. Let $k_s = 0.25$, the rest being as in (644). Then $y_{ch} = 51.4 \text{ m}$, $k_{ch} = \frac{3}{8}$, and $\delta_s = 0.53 \text{ mm}$.

646. If we increase k_s further (make the spars and struts more massive), we reduce the size of the vessel; the thickness of the shell is reduced.

In case c we may also increase n by a factor 3; then (641) and (643) show that y_{ch} is reduced by a factor 3, which requires from (658) a shell 3 times thinner. Then $2y_{ch} = 34.36 \text{ m}$,
 $n = 18$, and $\delta_s = 0.177 \text{ mm}$.

The shell is of inadequate thickness, and the size of the airship is enormous.

647. Case e of (615) has a shell of such small size that the

safety factor of the shell and the other parts may be taken as more than sufficient. In fact, formula (592), for a shell of constant thickness, shows that the safety factor is inversely proportional to y . Therefore the safety factor of a shell of small size made of

ordinary commercial tinplate needs no attention at all.

From (615) and (618) we have

$$aUk_s + \frac{8}{3} \pi y_{11} x \left(1 + \frac{2}{5} \cdot \frac{y_1^2}{x^2} \right) \eta_{\gamma} \delta_{ss} + Gk_{ch} = aU(1 - e).$$

We put

$$aUk_s + Gk_{ch} = aUk_{s,ch}$$

in which $k_{s,ch}$ is the sum of the coefficients for spars, struts, and chains, the weight of the last being taken as proportional to the upthrust aU . Then eliminating U by means of (627) or (612), we have

$$y_1 = \frac{\eta_{\gamma} \delta_{ss} \left(1 + \frac{2}{5} \cdot \frac{y_1^2}{x_1^2} \right)}{0.4ak_U (1 - e - k_{s,ch})}.$$

648. Here we put, for example: $\eta = 1$, $\gamma = 2.5$ (aluminum),

$\delta = 0.2$ mm (thinner than ordinary tinplate by a factor $1-1/2$), $a =$
 $\delta_s = 0.001$, $k_u = 1$, $e = 0.4$, $k_{s, ch} = 0.2$; we neglect $2y_1^2 / 5x_1^2$ to get
 that $y_1 = 25/8$ m and $2y_1 = 25/4$ m.

Such airships may be made for instruction in design rather than for practical use.

The over-all height will be only $25/8$ m if δ_s is made smaller by a factor two. Aluminum sheet $1/12$ mm thick feels more rigid than the material of a visiting card. This design may be used for practical construction.

It is very difficult to construct the shell of a small airship from corrugated metal, but there is no difficulty in using flat sheets [see (342-346)].

649. Case f is applicable only to relatively small airships, whereas case g is applicable mainly to vast ones.

In these the spars, struts, and chains are designed to sustain the action of disruptive forces; the resistance of the shell is neglected, and its thickness is determined by considerations of practicality.

The equation for 27_1 is, from (615), (618), and (633):

$$G \left(\frac{9}{4} + k_{ch} + b \right) + \frac{8}{3} \pi y_1 x_1 \left(1 + \frac{y_1^2}{x_1^2} \right) \eta_{y_s} \delta_s = aU (1 - e).$$

We use (621) and (612) to eliminate G and U ; simplifying and deriving y_1 , we have

$$y_1 = \frac{A}{2} + \sqrt{\frac{A^2}{4} - B},$$

in which

$$\frac{A}{2} = \frac{k_U \cdot (1 - e) \cdot K}{4\gamma_s \left(1 + \frac{y_3}{y_1}\right) \left(\frac{9}{4} + k_{ch} + k_b\right) n}$$

and

$$B = \frac{5\eta\delta_s \left(1 + \frac{2}{5} \cdot \frac{y_1^2}{x_1^2}\right) \cdot K}{4a \left(1 + \frac{y_3}{y_1}\right) \cdot \left(\frac{9}{4} + k_{ch} + k_b\right) n} .$$

650. We put $k_u = 1$, $e = 0.5$, $K = 60 \text{ kg/mm}^2$, $\gamma = 7.5$ (iron or steel), $y_3 = y_1$, $k_{ch} = 3/8$ [see (634)], $k_b = 0$, $\delta_s = 0.2 \text{ mm}$, $n = 6$, $\eta = 1$, and $a = 0.001$; $2y_1^2/5x_1^2$ is neglected, as before.

Then $y_1 = 54.8 \text{ m}$ or $y_1 = 8.7 \text{ m}$, so the shell can be 109.6 or 17.4 m in diameter.

651. The tinplate assumed is 1-1/2 times thinner than the ordinary commercial plate used for cheap pans and so on. The shell together with its massive parts may be considered practicable even for iron 0.15 mm thick, which is also much used and which I have tested.

Putting $\delta_s = 0.15 \text{ mm}$ and using the conditions of (650), we have $y_1 = 57.26 \text{ m}$ and $y_1 = 6.26 \text{ m}$.

The lesser diameter is then about 12-1/2 m, which is only

slightly more than that of recent (1907) airships, e.g., Lebody's.

652. A further calculation with $\delta = 0.3$ (ordinary tinplate) gives $y_1 = 48.89$ m and $y_1 = 14.61$ m.

These dimensions are vast for the shell of the first airship ($2y_1 = 29.22$ m).

653. We put $\gamma = 2.5$ and $K = 20 \text{ kg/mm}^2$ in (649) for an aluminum shell; then with the conditions of (650), but with $\delta = 0.15$ mm and 0.30 mm, we have $y_1 = 1.93$ and 61.57 m (0.15 mm) and $y_1 = 4.00$ and 59.50 m (0.3 mm).

The least diameter of an aluminum airship with a shell 0.15 mm thick is then about 4 m.

654. We see from (649) that $A^2/4 > B$; if this is not so, the shell will be too heavy, so the airship will not rise. From this we have

$$\delta_s < \frac{Ka(1 - e)^2 k_1}{20ny_s \left(1 + \frac{y_1^2}{y_1}\right) \left(1 + \frac{2}{5} \cdot \frac{y_1^2}{x_1^2}\right) \eta}$$

Then the conditions of (650) give that $\delta_s < 1.11$.

The greatest thickness for the shell under these conditions in case f is thus 1.11 mm.

Then $y_1 = A/2$, so we get the half-height of the thickest shell as $y_1 = 63.5$. The other limit, $\delta_s = 0$, gives $y_1 = A$ and $y_1 = 0$.

The thickest shell will thus have $2y_1 = 127$ m and the thinnest

$2y_1 = 0$.

655. The formulas of (649) give two solutions for the height of the shell, but this does not mean that only these two sizes are possible under given conditions, e.g., those of (650). In fact, we can put (649) as

$$y_1 = \frac{C}{n} \pm \sqrt{\frac{C^2}{n^2} - \frac{D}{n}},$$

in which C and D are taken as constants. For a given n we find only two values for y_1 ; e.g., 57.26 and 6.26 m, as in (651).

But if n is increased, and this (increased safety) is permissible, then the C^2/n^2 term will decrease more rapidly than D/n , so the limits of y_1 will come closer together. The two roots for y_1 become the same when $C^2/n^2 = D/n$.

From this formula we see that this occurs when

$$n = \frac{C^2}{D}.$$

For instance, for the case of (651) we have $n = 12.6$, or an increase by a factor 2.1 in the safety relative to the previous case, in which n was 6 [see (650)]; y_1 will be $C/n = 15.12$ m.

We can therefore make shells of heights not only 114.5 and 12.5 m, as in (651), but of all intermediate sizes, which will be of higher safety factor.

656. There are ways of reducing y_1 in cases a-e (633, 643, and 649) other than increasing n, such as the following:

1) reduction in e (relative weight of shell), which in part is favorable, because more upthrust will be available for the passengers, cargo, and so on; if the proportion going to the shell is halved ($e = 0.25$ instead of 0.5), the height is reduced by a factor 2, but the weight of all the other parts may be increased by 0.25 of the upthrust.

2) a less strong material may be used (K can be reduced);

3) the pressure y in the lower part of the shell can be increased, which gives a gain in stability;

4) the density γ may be increased for a fixed K ; and finally

5) $k_{ch} + k_b + k$ may be increased (in accordance with the design of vessel), which also reduces y . The height $2y$ is not dependent on a (except in case f), namely is not dependent on the density difference between the light gas and air.

The dimensions of course increase if the quantities are altered in the reverse way. For instance, doubling of the strength of the material involves a doubling of the dimensions and an 8-fold increase in the upthrust.

To conclude this section we may note that metal airships are the more rigid the larger they are.

The least size for an iron shell is 12.5 m in height, or 4 m for an aluminum one.

An aluminum shell 12.5 m high is very rigid (in view of its massive parts, the shell also being nearly as thick as roofing iron).

Schwarz's and Dupluie de Loma's airships were larger; the above size is close to that of the current (1907) French airships.

Schwarz used aluminum 0.2 mm thick in his airship, which is less than half the thickness (0.45 mm) I now propose.

Zeppelin's and Schwarz's airships had internal lattice structures, which provided rigidity but consumed much of the upthrust.

This rigidity and lack of flexibility in the shell make it extremely sensitive to the slightest shocks, which in part may be why the Zeppelin trials were carried out over water.

XIV. MOTION OF AN AIRSHIP*

A. Independent Uniform Horizontal Motion

By independent motion I mean movement of the dirigible in a stagnant atmosphere (in the absence of wind). Such motion may be horizontal, vertical, or inclined and may be performed by the use of engines or the upthrust of the vessel (positive or negative) when this is not balanced by ballast.

In this chapter I consider only horizontal motion produced by the power of the motors.

The force on a plane moving along a straight line perpendicular to itself is given by Poncelet's theoretical formula as

$$\frac{d_a}{2g} \cdot Sv^2, \quad (1)$$

in which d_a is the density of the fluid, g is the acceleration due to gravity, and S is the surface area of the plate, which is of small length or not elongated.

Some have used far from accurate experimental results to assume that the resistance of a medium is proportional to S^n , with $n > 1$; if this were so, calculations on the speeds of water craft would be incorrect, but this is not found to be so. The resistances offered by air and water are, in fact, found to show an unusual and unexpected similarity.

Calieter and Colardo found that the forces in their experiments were only slightly greater than those predicted by Poncelet's theory (by a factor of about 1.2); the lengthwise force on the bird-shaped surface of an airship will be much less. Let it be less than that given by (1) by a factor u_f ; then the force exerted on the

vessel in the direction of its longitudinal motion is

$$P = \frac{\gamma_a F_p v^2}{2g u_f}, \quad (2)$$

in which γ_a is the density of air; u_f is the mean form factor of the body, rudders, gondola, supports, and so on; F_p is the sum of the projections of these parts on a plane normal to the direction of the flow; and v is the flow speed.

P consists of two principal resistances: that of the body P_1 and that of the other parts P_2 . We have

$$P_1 = \frac{\gamma_a F_1 v^2}{2g u_1} \quad (3)$$

and

$$P_2 = \frac{\gamma_a F_2 v^2}{2g u_2}, \quad (4)$$

in which u_1 and F_1 are the form factor and cross-section (projection) of the body, u_2 and F_2 being the same for the other parts.

Comparison of (2) with (3) and (4) gives

$$\frac{F_p}{u_f} = \frac{F_1}{u_1} + \frac{F_2}{u_2}. \quad (5)$$

Of course, u_1 is dependent on the elongation x_1/y_1 of the airship, on the absolute dimensions, on the shape, and on the speed; it is thus a function of four variables: $u_1 = F(x_1/y_1, x_1, v, \text{shape})$.

My experiments indicate the same as regards u_2 (for the other parts of the vessel). The useful or minimal work required per unit time to maintain the uniform motion is P_v ; but the work produced by the vessel's engines is very much greater, because the propeller sets the surrounding air in motion, so part of the work from the motor produces a useless perturbation in the medium around the screw.

The work produced by the engines must therefore be greater by a factor k_h (in fact, two) and so is

$$N = Pvk_h, \quad (6)$$

in which k_h is dependent on the diameter and performance of the screw (with respect to the total resistance of the airship) as well as on the position relative to the body; k_h approaches unity as the design is improved, the diameter is adapted best, and the position is improved.

F_p is the sum of the projected areas of the parts of the airship on a plane normal to the direction of motion, so

$$F_p = \pi y_1^2 k_F, \quad (7)$$

in which y_1 is half the height (radius of the largest cross-section of the expanded shell) and k_F is a dimensionless factor; this should,

on the one hand, be less than unity, on account of the deviation from circular form in the cross-section, while on the other hand it should be larger than unity, on account of the projection of the chains, ties, controls, keel, and other parts.

My large metal airships have k_F close to unity, because the chains are not numerous (or are completely covered) and are of good cross-section as regards resistance; the gondola and the control surfaces may be considered as almost flat.

We eliminate P from (6) by means of (2) and then S by means of (7) to get

$$v = \sqrt[3]{\frac{2gu_F N}{\pi \gamma_a k_F k_h y^2 l}} \quad (8)$$

Here

$$N = E_n \cdot k_M \cdot Q, \quad (9)$$

in which E_n is the energy (work) produced by the vessel's engines per unit weight (kg) in unit time (second); Q is the upthrust; and k_M is the motor factor (part of the upthrust taken by the motors).

The upthrust for a parabolic airship is

$$Q = U (\gamma_a - \gamma_g) = \frac{16}{15} k_u \pi \gamma_1^2 x_1 (\gamma_a - \gamma_g), \quad (10)$$

in which k_u is the factor for the volume U filled with gas (because

the shell is not fully inflated), x_1 is half the length of the vessel (rather, shell), and γ_g is the density of the gas in the shell.

We eliminate N and then Q from (8) by means of (9) and (10) to get

$$v = \sqrt[3]{\frac{32}{15} g \left(1 - \frac{\gamma_g}{\gamma_a}\right) \cdot \frac{k_U}{k_F} \frac{E_n k_m}{k_k} u_F x_1}. \quad (11)$$

It must be pointed out that this parabolic volume is very sharp-ended, imperfect, and (as regards upthrust) unsuitable.

Actual airships have much greater completeness of water displacement (the naval term), but the present shape has the advantage as regards resistance.

In speaking of a parabolic shape, I have in mind mainly the cubic displacement; the shape of the body can be different, and the midsection (area of greatest cross-section) can be brought somewhat forward towards the nose.

The following conclusions are drawn from (11):

A. The independent forward speed of the vessel is not dependent on γ_a ; it is governed solely by the ratio γ_g/γ_a of the density of the material filling the vessel to the density of the surrounding medium*.

This ratio is that of the light gas to that of air in this case; it remains the same if the shell expands and contracts freely**. This means that the speed of the independent motion does not alter

*This is based on the assumption that E_n remains unaltered in spite of variation in γ_a .

**Even in spite of changes in gas temperature and pressure, if these are the same inside and outside the shell.

when the balloon rises or falls, if we neglect any change in E_n and in the form factor arising from volume changes in the gas or from variation in k_u/k_F , which variation is slight.

If we use (11) to compare vessels of the same x_1 floating in any medium (rarefied or very dense air, or even water), we find that a water craft (steamship) has a very small advantage over an air one (airship). The factor $(1 - \gamma_g/\gamma_a)$ for the latter filled (say) with hydrogen is $13/14$, whereas for a steamship it is almost one, for a sea-going vessel is filled with air, whose density is minute relative to that of water.

Extraction of the cube root in (11) gives us that the speed of the water vessel will be larger by $\gamma_g/\sqrt[3]{3\gamma_a}$, or $1/42$, than that of the air one containing hydrogen. In deducing this we assume that the other quantities appearing in (11) are the same, which can scarcely be said to be the case for u_F (form factor), for example.

If our atmosphere were 10, 100, or 1000 times denser or more rarefied, airships of the same size and of the same construction would move neither more slowly or more rapidly as a result.

This involves the assumption that E_n remains unaltered, of course. This can be insured if the change in density is slight by adjustment of the shaft speed, alteration of valve sizes, increasing the draft in furnaces of steam boilers, and so on.

But there is a limit to this. We may assume that E_n increases in proportion to the density of the air (oxygen content) for internal-combustion engines generally but tends to decrease also on account of the lower speed of escape from valves and pipes, on account of the higher density; the result is that the shaft speed is inversely proportional to the square root of the air density.

The final result is that E_n probably increases roughly in proportion to the square root of the density of the medium supporting the combustion, so in (11) we put

$$\sqrt[3]{E_n} = \sqrt[3]{E_{n1} \sqrt{\frac{\gamma_a}{\beta_{a1}}}} = \sqrt[3]{E_{n2} \cdot \frac{\gamma_a}{\gamma_{a1}}} \quad (11_1)$$

For instance, the density at a height of 12 versts is 4 times lower ($\gamma / \gamma_{al} = 1/4$), so E_n is reduced by a factor 2 and the speed v of the airship by a factor

$$\sqrt[6]{\frac{\gamma_{al}}{\gamma_a}} = \sqrt[6]{4} = 1.26,$$

or by 20%.

In these formulas E_n denotes the energy of the motor corresponding to the density γ_a of the medium.

Thus we see that the variation in E_n for dirigibles of identical size and similar design at various heights results in a speed proportional to the sixth root of the density of the medium that supports the combustion. The table following expresses this.

B. The speed of the vessel is dependent on the x_1 dimension [see (11)].

The form factor u_f alters little in response to change of size if the dimensions increase in proportion, i.e., if the vessel remains geometrically similar as it enlarges or shrinks. In this case

$$x_1 = y_1 \lambda, \tag{12}$$

in which λ is the constant ratio of the length of the shell to the height. This shows that the independent horizontal speed of the airship increases with the size; conversely, models of airships cannot reach high speeds, and their reduction u_f accentuates this.

f

TABLE 14-1

Height (of flight) of dirigible, km	0	1	2	3	4	5	10
rarefaction, γ_a / γ_{al}	1	0.9	0.8	0.715	0.636	0.564	0.39
relative speed	1	0.98	0.96	0.94	0.92	0.91	0.85
% reduction in speed	0	2.0	4.2	6.4	8.7	9.9	10.78

A set of similar dirigibles varying greatly in size will move with different speeds, which are proportional to the cube roots of their linear dimensions [see (11)].

The speed is also increased if the length $2x_1$ is increased while keeping the height $2y_1$ unchanged provided that u_f increases or remains unchanged.

This is applicable to very short (not elongated) airships; a highly elongated shell gives the same speed when $2x_1$ is increased, because u_f is reduced almost exactly in proportion to the increase in $2x_1$.

In general, any change in speed is governed by the change in u_x .

f l

If a destroyer could attain a speed of 70 km/hr, an airship of the same size under the same conditions could reach the same speed; if it were larger, its speed would be correspondingly greater, provided that the motor increases correspondingly.

For instance, the destroyer might be 30 m long and the airship 240 m (8 times larger), so the speed of the latter would be at least 2 times greater, or 140 km/hr. The dimensions of the largest possible metal airships are larger by a further factor 8, so their independent speed under identical conditions would be larger by a further factor 2, or 280 km/hr, leaving aside any improvement in u_f and consequent increase in speed from this cause.

C. Formula (11) further shows that the speed v is proportional to the cube roots of the motor energy E_n , of $1/k_h$ (representing screw perfection), of the form factor u_f , and of the relative weight k_m of the motors. For instance, an increase in $E_n u_f k_m$ by a factor 8 increases v by a factor 2.

D. The speed of the vessel remains unchanged if the product $E_n u_f k_m$ is unaltered; so, if we assign a decreasing fraction k_m of the upthrust to the motors, we must either increase the size of the vessel in the same ratio or increase the energy of the motors leaving the size unchanged, if we are not to lose speed. Conversely, if we wish to reduce the dimensions of the vessel by some factor, we must either devote a larger fraction k_m of the upthrust to the motors or increase the energy E_n of these by the same factor in order to leave the speed v unchanged.

For instance, $k_m E_n$ must be increased by a factor 4 if we wish to reduce the size by a factor 4 without affecting the speed; this can be done in various ways, e.g., by increasing the energy by a factor 2 and devoting twice the proportion of the upthrust to the motors.

E. (11) shows that the speed is also dependent on the density of the gas in the airship, being proportional to

$$\sqrt[3]{1 - \frac{\gamma_g}{\gamma_a}}$$

This relation is represented by the following table, in which the density of the light gas varies from zero to unity (i.e., up to the density of air):

TABLE 14-2

γ_g / γ_a	0	0.1	0.2	0.3	0.4	0.5	0.6	0.7	0.8	0.9	1.0
v	1.00	0.97	0.93	0.89	0.84	0.79	0.74	0.67	0.58	0.46	0

The second line shows that the forward speed decreases extremely slowly as the density increases (this speed has been taken as unity for an impossibly light ideal gas, namely one of zero density). A gas density of 0.1 (nearly 1.5 times that of hydrogen) reduces the speed by only 3%; a density of 0.4 (near that of heavy illuminating gas) reduces the speed by 16%, or by about 1/6 of the ideal value. Even for the density of air heated to 100° the speed is reduced by only 33%, or 1/3.

On the other hand, increase in gas density is accompanied by other very important defects: the upthrust decreases in proportion to $\gamma_g - \gamma_a$ and hence is represented by the sequence 1, 0.9, 0.8, 0.7, 0.6, 0.5, 0.4, 0.3, 0.2, 0.1, and 0.

This fall in upthrust requires corresponding reductions in the weight of shell and so forth, which makes construction very difficult. The useful (free) upthrust (e.g., the number of passengers and so on) is also reduced in the same ratio.

Equation (11) enables us to find the absolute value of v.

First we take fairly ideal conditions: $g = 9.8 \text{ m/sec}^2$, $E_n = 25 \text{ kg-m per kg weight}$ (which implies a weight of 3 kg per horsepower, or 75 kg-m/sec), $k_m = 1/8$, $u_f = 50$, $x_l = 105 \text{ m}$ (my iron airship for 200 passengers, of size equal to a large steamship), $k_u/k_F = 1$, $k_h = 2$, and $\gamma/g = 0.1$; then (11) gives $v = 53.7 \text{ m/sec}$ or 193 km/hr^* .

The dimensions of the largest possible metal airships are 10 times larger, so these would have speeds of 116 m/sec or 417 km/hr under identical conditions.

Of course, such speeds and airships can only be dreamt of at present. Now we come down to earth to ordinary dirigibles and impose for them strict conditions, which from my point of view it is difficult to doubt as to their applicability. E_n (motor power)

varies greatly; it ranges up to 75 kg-m/sec per kg for gas or benzine motors at present. Airships presently use benzine motors of power 3 or 4 times lower ($20\text{-}25 \text{ kg-m}$). The specific weight of the engine may be put as $75/E_n$, which is the weight of the motor per horsepower.

For our calculations we may reasonably assume a specific weight of 4 kg per hp (E_n of 20 kg-m/sec per kg weight); k_m (relative weight of the motors) may be about $1/8$ of the total upthrust of the vessel. We assume an airship of displacement $10\,000 \text{ m}^3$ (upthrust 10 tons).

*My metal shells for dirigibles are protected in nine countries (Russia, Germany, Austria, Great Britain, the United States, and so on); the patents were taken out in 1910-1911. Improved all-metal shells without soft folds cannot be protected, because the laws of all countries forbid the grant of patents to inventors who have already published their inventions in the press, as I did in 1892 and even earlier (in the 1890s), when I gave a report of my invention in Division 7 of the Imperial Russian Technical Society.

The volumes of current dirigibles* range up to $20\,000\text{ m}^3$, and the displacement is still tending to rise, so this 10 tons is not an overestimate of the lift. We assign $1/8$ to the motors, which gives them 1250 kg and hence a power of $25\,000^{**}$ kg-m/sec or 333 hp, which does not exceed real values.

Experiments (mine and others') indicate that u_f (form factor) increases with the size and speed of the airship.

Even a model 33 cm long and 10 cm wide moving at 4 m/sec had a form factor of 14. No lesser value should be assumed. In my view, good shapes should give values up to 50, as for ships.

The length $2x_1$ for moderate volumes is about 100 m in practice, so the average half-length x_1 is about 50, which I take as basic value. One has already heard talk of planned airships of displacement $50\,000$ to $100\,000\text{ m}^3$, which correspond to a large ocean-going steamship of length about 200 m.

My calculations indicate that the strength of metals is such as to allow dirigibles up to 2000 m in length; I do not know whether these are possible in other respects, but my calculations show that they are as regards strength of shell.

Here k_u (the part filled with light gas as a ratio to the volume of the fully inflated airship) is taken as 0.7, so 0.3 of the maximum volume (nearly $1/3$) is taken by airbags or is left for expansion during ascent. This reserve for expansion allows the airship to rise to heights of at least 2 km.

We put k_F as 1.4, which means that the resistance of the stays, gondola, rudders, and so on is taken as equal to the resistance of the shell filled with hydrogen; this is excessively generous as regards my metal airships and is quite adequate for ordinary dirigibles.

The values are therefore: $u_f = 14$, $\gamma_a = 0.0012\text{ (t/m}^3\text{)}$,

*The British Naval Airship 1; construction has begun afresh.

**The mss had 201 250 (Editor).

$\gamma = 0.0002 \text{ (t/m}^3\text{)}$ (a gas 6 times lighter than air and slightly more than 2 times as heavy as hydrogen), $k_u = 0.7$, $k_F = 1.4$, $E_n = 20$ (specific weight of motor 3.75 kg/hp), $k_m = 1/8$, $k_h = 2$ (k_h is even less for aeroplanes and ranges down to 1.3, because the efficiency $1/k_h$ of the screw ranges up to 0.75; but for an airship I assume only 0.5 at present), $x_1 = 50 \text{ m}$ ($2x_1$ ranges up to 156 m in current dirigibles, as in the Naval Airship 1 in Britain). Then from (11) we have $v = 19.68 \text{ m/sec}$ or 70.8 km/hr .

I have made some other calculations on this airship. The length of the shell or dirigible is $2x_1 = 100 \text{ m}$; the height when fully inflated, $2y_1$, is given by (12) with the fineness ratio put as seven, so $2y_1 = 14.3 \text{ m}$.

The volume U is given by (10) as

$$U = \frac{16}{15} \pi k_U y_1^2 x_1^2 = 5986 \text{ m}^3. \quad (13)$$

This equation also gives us that A (upthrust of the dirigible) is 5986 kg; of this we assign $1/8$ to reserve and the same to lifting H men, whose number (taking each as 75 kg) is then

$$H = \frac{Q}{75} \cdot k_M = 10 \text{ men}. \quad (13)_1$$

The weight of the motors and the spare lift is

$$Q_k = 748 \text{ kg.} \quad (14)$$

The power (horsepower) is

$$p = \frac{Q_k E_n}{75} = 199.5 \text{ hp} \quad (15)$$

The power per passenger is thus about 20 steam horsepower.

The force P of the opposing airstream on the entire vessel is given by (2) and (7) as

$$P = \frac{\pi k_F \gamma a}{2g \cdot u_f} y_1^2 v_1^2 = 381 \text{ kg.} \quad (16)$$

The numbers have been rounded off a little to give the following table containing corresponding values for other sizes of airship (100 to 2000 m long and 14 to 286 m high). In all cases $k = 1/8$, with about 20 hp per passenger.

The columns give $2x$ (length of shell of gasholder), $2y$ (height), U or Q (volume of gas in m^3 and lift in kg), Q_k ($1/8$ of this lift, or weight of motors, the same going to passengers and to reserve lift, total $3Q/8$)*, p (power of motors, in steam horsepower), H (number of passengers), v (speed in m/sec), v_1 (speed in km/hr),

*Leaving $5/8$ of the upthrust for shell, gondola, and so on.

TABLE 14-3

Length, m	height, m	volume (lift), m^3 or kg	weight of motors, also re- serve lift	power, hp	No. of people on vessel	speed, m/sec	speed, km/hr	air resistance, kg
$2x_1$	$2y_1$	U	Qk_M	P	H	v	v_1	P
100	14.3	6 000	750	200	10	19.7	70	380
120	17.1	10 368	1 296	345.6	17	20.9	74	547
150	21.4	20 250	2 531	675	34	22.5	80	855
200	28.6	48 000	6 000	1 600	80	24.9	88	1 520
300	42.9	162 000	20 250	5 400	270	28.4	101	3 420
400	57.1	384 000	48 000	12 800	640	31.3	111	6 080
600	85.7	$1\ 296 \cdot 10^3$	162 000	43 200	2 160	35.9	127	13 680
1000	142.9	$6 \cdot 10^6$	750 000	200 000	10 000	42.4	150	38 000
2000	285.7	$48 \cdot 10^6$	6 000 000	1 600 000	80 000	53.4	190	152 000

and P (lengthwise force of opposing airstream on whole airship in kg).

The preceding table shows that the speed increases continuously with the size of the airship; (11) shows that the speed remains unchanged if $k x$ is constant, which occurs when k varies

in inverse proportion to x .

If 70 km/hr is taken as sufficient for practical purposes, then k (part of upthrust assigned to motors) can be reduced in accordance with the increase in x (size). This then gives an economy in horsepower per passenger, as the following table shows.

TABLE 14-4

Height $2y$ ₁	14.3	17.1	21.4	28.6	42.9	57.1	85.7	142.9	285.7
relative weight of motors, k _m	0.125	0.104	0.833	0.062	0.042	0.031	0.021	0.012	0.006
power per passenger, p/H	20	16.7	13.3	10.0	6.7	5.0	3.3	2.0	1.0
power p	200	288	450	800	1800	3200	7200	20000	80000

The first line gives the height of the middle part of the shell (m); the second, k (part of upthrust assigned to motors); and the third, p/H (horsepower per passenger). This last is one for an airship

having the height of the Eifel tower. The force from the airstream will also be much less than the P given in the previous table. We should not forget that the speeds of these vessels are constant (70 km/hr) only when there is no very strong opposing wind to be overcome.

Such speeds are hardly reached by present dirigibles, but there are reasons for this: the vast resistance of the stays and bubble-shaped stabilizers, the poor shape* of the body, which often takes the form of a sausage or pointed cylinder (it would be of interest to trace the evolution of the shape in steamships). Further, there are the inevitable folds in the soft shell, the airscrew (of size insufficient to correspond to the vast resistance of the shell), the stays, stabilizers, and so on.

I believe that the speeds listed in the above two tables will not merely be reached when all these defects are removed but will also be greatly exceeded.

Formula (11) shows that E_k must be increased if we wish to reduce $2x$ (which has advantages and can be done if organic materials are used for the shell) while retaining the speed of 70 km/hr.

If, for example, we wish to reduce the 100 m of the shell to 50 m, we can do this either by assigning twice as much lift to the motors ($1/4$ instead of $1/8$) or by doubling the energy of the latter (use a specific weight of 2 kg/hp instead of 4). Alternatively,

both could be increased by a factor $\sqrt{2}$, the speed of 70 km/hr being retained with a consumption of light gas reduced by a factor of 8 (750 m^3 instead of 600 m^3). Airships smaller than this are not generally made.

The formulas enable us to show that an airship of payload equal to that of a steamship has the higher speed. We eliminate x_1 from (11)

on the basis that

$$x_1 = y_1 \lambda, \quad (12)$$

*Usually deviating from the underwater shape of a steamship.

in which λ is the ratio of the length of the fully expanded shell to the greatest diameter. We then put that the lift Q of (10) corresponds to an unaltered value of A :

$$A = \frac{16}{15} \pi k_U (\gamma_a - \gamma_g) y_l x_l^2.$$

We eliminate x_l and y_l from (11) by means of these two equations to get that

$$v = \sqrt[3]{\frac{32g}{15} \frac{k_M}{k_h} \frac{k_U}{k_F} \frac{E u \lambda}{P f}} \sqrt[9]{\frac{15A \left(1 - \frac{y_g}{y_a}\right)^2}{16\pi k_U \lambda \gamma_a}}. \quad (17)$$

This shows that the speed for a fixed upthrust A falls as we increase the density of the air (γ_a) or of the supporting medium generally. For instance, consider three vessels of the same payload (e.g., ten passengers) one floating in the air near the ground, another in water, and the third at a height such that the air is 729 times less dense; the last has a speed $\sqrt[9]{729}$ (about 2) times greater than that of the first, while the second has a speed about 2 times less than the first. In other words, the speed of a water craft for a given payload A is about half of that of an airship floating at ocean level, while airships designed for constant payload but various heights will have speeds inversely proportional to $\gamma_a^{1/9}$ and hence higher speeds in the higher layers of the atmosphere.

We should not forget the conclusion of (11₁) on the effects of the density of the medium on the energy of the motors.

Formula (17) shows that the speed v is proportional to $\frac{\sqrt[3]{E_n}}{\sqrt[6]{\gamma_a}}$;
 (11₁) gives that

$$\sqrt[3]{E_n} = \sqrt[3]{E_{n1}} \sqrt[6]{\frac{\gamma_a}{\gamma_{a1}}} .$$

Then the speed v is proportional to

$$\sqrt[3]{E_{n1}} \cdot \sqrt[18]{\frac{\gamma_a}{\gamma_{a1}}} ,$$

or to $\sqrt[18]{\gamma_a}$.

This means that v even falls as the density decreases (for a given A), but only very slowly. For instance, the density of the air is reduced by a factor 4 at a height of 12 versts, so the speed of an airship is reduced by a factor $\sqrt[18]{4}$ or 1.08, namely by 7.4%.

The table following expresses this.

(17) also shows that the speed is proportional to the ninth root of A or of the displacement (tonnage). This shows that any advantage in this respect from increasing the volume of the airship is slight; but large dirigibles have some very important advantages: it is possible to provide a thick metal shell (which is cheap, in-

combustible, impermeable to gases, and unvarying), a gondola filled with passengers, cheap transportation, solid and reliable motors together with stability of all kinds (e.g., a closed incombustible gondola), lift adjustable by heating the light gas (hence ready control of vertical motion), and so on.

TABLE 14-5

Height, km	0	1	2	3	4	5	10
speed reduction, %	0	0.7	1.4	2.1	2.9	3.3	5.9

The above table shows that the fixed speed (70 km/hr) leads to reduction in k (proportion devoted to motor) as the size increases.

This also has advantages, for it increases the net upthrust, which can be utilized to increase the reliability of the motors (which are already reasonably solid at 4 kg specific weight, though) and of the other parts or to increase the payload.

For instance, $1/8$ of the upthrust goes to the motors when the height is 14 m, but only $1/160$ (20 times less) when the height is a little less than that of the Eifel tower, and this without loss of independent horizontal speed.

The vast sizes of airship in these tables are, of course, merely speculations, although they are based on strictly scientific calculations not given here; but we have seen that life has often made scientific dreams into realities. For instance, the phonograph unexpectedly and simply solved the problem of the talking machine thereby surpassing Helmholtz's detailed theories. Spectral analysis solved the problem of the composition of heavenly bodies, although the possibility of solving this problem even in the future had been denied by the most learned thinkers. Much might be said on this. I am not the only one to have thought of large airships; Giffard drew

up plans for one of volume $220\,000\text{ m}^3$. Although an idealist, he was also an experienced practical engineer who had personally tested out his ideas and spent a fortune on it. Blindness and suicide ended his life and work; but now engineers are planning dirigibles of volume

$50\,000\text{ m}^3$. The tendency to increase the volume of airships is not declining, but difficulties arise over lack of strength, combustibility, and cost for the current organic shells, quite apart from doubts over the need for such vast expense. The general public knows little about airships, and for this reason the powers that be do not support the work.

B. Inertia of a Vessel

(Inertial Range)

It is said that an airship is a bubble and does not have high inertia; give such a bubble a push, and it will travel only a short way before coming to rest on account of the resistance of the air and its low kinetic energy. On the other hand, give a push to a massive body sufficient to give it the same speed, and it will travel far (e.g., on wheels or on ice skates), covering a considerable distance before it stops because it has lost its kinetic energy in overcoming resistance.

This is the kind of inertia I have in mind.

But the matter is not so simple as it might seem at first sight; we must know the effects of shape, size, and so on.

Let us compare the kinetic energy (vis viva) of our rapidly moving airship with the resistance the air puts up; this will give us an idea of the massiveness (inertia relative to that of the medium).

We take the general case, in which the weight of the vessel is not equal to that of the medium it displaces, which makes it applicable to living and dead aeroplanes (i.e., to insects, birds, and artificial flying machines).

The kinetic energy is $mv^2/2g$, in which m/g is the mass of the vessel. If the shell has the smooth parabolic form of (13), we have

$$m \frac{v^2}{2g} = \frac{16}{15} \frac{\pi y^2}{1} \times \frac{k_U}{1} \gamma_v \frac{v^2}{2g} \quad (18)$$

Here γ is the mean density of the vessel (total weight divided by the volume).
From (2) and (7) we have the resistance of the medium as

$$P = \frac{\pi k_F}{2g u_f} y^2 v^2 \quad (19)$$

The inertness (inertial range) of the vessel is expressed by dividing the kinetic energy by the resistance of the medium at that speed.

Dividing and simplifying the last two equations, we have this as

$$\frac{mv^2}{2g} : P = \frac{16}{15} \cdot \frac{k_U}{k_F} \cdot \frac{\gamma_v}{\gamma_a} u_f \quad (20)$$

The result expresses the distance traveled by the initially moving vessel if the resistance P does not fall; the engine is, of course, not operating.

The formula shows that this inertial range (relative kinetic energy of the moving vehicle) is directly proportional to:

- 1) the dimensions (x_l);
- 2) the form factor u_f ; and
- 3) the relative density γ_v/γ_a (ratio of the mean density γ_v to the density γ_a of the surrounding medium)*.

For other shapes (sphere or still worse) the relative energy will be small compared with bodies of good shape (relative to the resistance of the medium, that is).

It will also be small for small vessels (x_l small) because the form factor is low for small x_l , no matter how good the shape may be, on account of the need to overcome friction. We may say that this formula indicates that the inertial range of a large flying machine (other things being equal) increases with the size.

We now compare an aeroplane (with a closed body, such as Newport's) with an airship. On the one hand, the aeroplane has the advantage, because γ_v/γ_a is large; but u_f is much less, especially since x_l is much smaller than for a gas-filled vessel, so the problem is rather complicated.

If we assume the same inertial range for all vessels, the above equation shows that u_f , x_l , and γ_v/γ_a are inversely proportional one to another. For example, in order to match as regards inertial range a bird ($2x_l = 10$ cm and $\gamma_v/\gamma_a = 500$) to an airship (relative density one) it is necessary for the latter to have $u_f x_l$ 500 times larger than for the bird. We assume that the form factor is 5 times that for the bird; then $2x_l$ must be 100 times larger, so the length is

* The formula also applies to artillery shells, vessels, and water animals.

1000 cm, or 10 m. The bird is small, so the resistance of the wings, as assumed in (5), is not far from the true value.

The little bird and the small model airship are thus of the same inertial range.

If now we replace the bird by an aeroplane of the same form factor but with a length of 10 m and a $\frac{\gamma}{\gamma_a}$ not less than 80, the

inertia (inertial range) becomes that of an airship 160 m long.

This is the maximum size for existing airships; their gas displacement (tonnage for ships) is 20 000 m³. It could be that highly pointed airships could now equal the aeroplane in this respect but the airship has other major advantages, since it requires no energy to support it in the air.

I therefore assume that the form factor of an aeroplane is so low relative to that of an airship that it is obliged to have wings, whose shape is such as to imply a large additional resistance. In addition, the small size and far from perfect present shape of the body also reduce the mean form factor. The relative energy of motion for the largest (in size) metal airships is not only undoubtedly larger than that for insects and other flying things; it is also larger than that for even the best aeroplanes.

The $\frac{\gamma}{\gamma_a}$ of the above formula becomes one if we wish to compare water craft one with another or with submarines or aquatic life, because the mean density of the balanced vessel is equal to that of the surrounding medium. The same applies to airships in vertical equilibrium at different heights, so in place of (20) we have

$$\frac{mv^2}{2g} : P = \frac{16}{15} \cdot \frac{k_U}{k_F} \cdot u_{F1}^x \quad (21)$$

This shows that the inertial range is independent of the medium ($\gamma = \gamma_a$), so this quantity does not appear; this means that the in-

ertial range of a water craft is equal to that of an airship provided that x and the form factor are the same, in spite of the vast dif-

ference in densities as between the media in which they float.

The relative inertia of a steamship is in no way greater than that of an airship under the same conditions.

But the inertial range of any vessel is proportional to its size x and form factor u ; the values for large fish and large

dirigibles are greater than those for small ones or those of less perfect shape, other things being equal.

The mean density γ of a steamship is to be taken as the mass divided by the volume of the underwater pater.

The inertial range of (20) indicates the capacity of a vessel, missile, or living being to coast a certain distance by virtue of its speed v on account of its inertia. We now examine this more closely. We have seen that the inertial range would express the distance the body could travel if the resistance were to remain unchanged in spite of the loss of speed. This is approximately true for a body moving in accordance with its inertia on a plane in a vacuum, being subject only to frictional resistance and gravity.

The work done by a vessel in rectilinear motion over a distance dx is Pdx , in which P is the resistance of the medium, or the force on the vehicle in the direction of motion. On the other hand, the loss of kinetic energy $mv^2/2g$ consequent on a fall in speed dv caused by the resistance is found by differentiation as

$$- m \cdot \frac{v}{g} \cdot dv.$$

The law of conservation of energy now gives

$$- m \frac{v}{g} dv = P \cdot dx . \quad (22)$$

We eliminate m and P by means of (18) and (19), simplify,

separate the variables, integrate, and determine the constant to get

$$x = \frac{32}{15} \cdot \frac{k_U}{k_F} \cdot \frac{\gamma_v}{\gamma_a} \cdot u_{f1} \ln \left(\frac{v_1}{v} \right). \quad (23)$$

Here v_1 is the initial velocity and v the final one, the logarithm being the natural one.

Consider motion to rest, namely $v = 0$, then $x = \infty$, so the body travels an infinite distance and hence never stops.

The formula shows that the distance traveled is constant for a given v_1/v , no matter what the absolute values of the speeds; but

it is directly proportional to the relative inertia (inertial range) of the vessel [see (201)].

In other words, the vehicle travels the same distance while losing a given fraction of its initial (large or small) speed; but this is directly proportional to the size of the body, to γ / γ_a , and

to the form factor.

This distance is also independent of the absolute density of the medium, being governed solely by the ratio of this to the mean density of the vessel. For instance, a water craft and an airship travel equal distances while losing (say) half their inertial speed, if conditions are the same for both. We have $\gamma = \gamma_a$ for steamships, fish,

and airships, because the mean density is that of the medium. Then we have from (23) for these that

$$x = \frac{32}{15} \frac{k_U}{k_F} u_{f1} \ln \left(\frac{v_1}{v} \right). \quad (24)$$

For instance, $k/k_u = 1$, $u_f = 50$, $x_l = 100$ m, and $v/v_l = 2$; the last denotes loss of half of the initial (arbitrary) speed v_l .

This gives $x = 7392$ m, or about 7 versts.

The calculations relate to an airship carrying 200 passengers or to a seagoing steamship of the same size. The conditions of the above are fairly ideal; the above are the worst conditions: $k_u = 0.7$, $k_F = 1.4$, $u_f = 14$, and $x_l = 50$ (airship for 10 men, displacement 6000 m^3); for $v/v_l = 2$ we have $x = 517$ m (range of $1/2$ a verst).

The vessel retains $1/2$ its initial speed (say, 10 m/sec) after covering this distance; then it can cover the same distance (500 m) while retaining half again (5 m/sec), as (23) and (24) show.

But the motion becomes ever slower and ultimately inappreciable. In (22)

$$dx = v \cdot dt, \quad (25)$$

in which t is time in seconds reckoned from the instance when the vehicle had a speed v_l .

We use (22) to eliminate dx and integrate to get

$$t = \frac{32}{15} \cdot \frac{k_u}{k_F} \cdot \frac{\gamma_v}{\gamma_a} \cdot \frac{u_f}{v_l} \cdot x \left(\frac{v_l}{v} - 1 \right). \quad (26)$$

The time taken to reach a given v/v_l is thus proportional

to $u \times \gamma / \gamma$ (inertial range, whether it be a vessel, airship, steam-
 $f \quad l \quad v \quad a$
 ship, glider, bird, fish, insect, artillery missile, and so on) and
 is inversely proportional to v ; no matter what v may be, the time
 $1 \quad 1$
 increases as v (or the final speed) decreases, becoming infinite
 when v is zero (total loss of speed).

Total stoppage thus takes theoretically an infinite time.

This treatment is true only in so far as the law of resistance
 used is correct (resistance proportional to the square of the speed),
 which cannot be taken as rigorously so; hence the conclusion is only
 a rough picture of the actual effects.

But the picture is the more nearly correct the closer the
 final speed v is to the initial speed v .

1

C. Relative Resistance, Specific Surface, and Specific Volume

Some calculations to elucidate the controllability of an air-
 ship appear in order here.

First we find the area of the largest cross-section of the
 shell per passenger.

The total area of the projection of the vessel on the plane of
 the cross-section is denoted by F , as before. This is
 p

$$F_p = \pi y_l^2 k_F.$$

But the good shape of the vessel means that this expression
 does not give us the resistance; F must be divided by the form
 p

factor u , which gives us the area equivalent to the resistance (at
 f
 the same speed, of course):

$$\frac{F_p}{u_f} = \frac{\pi k_F}{u_f} y_1^2. \quad (27)$$

The weight of the passengers is a fraction k of the up-thrust [see (10)]; let q_p be the weight of a passenger, so the number is

$$[H =] \frac{Q k_p}{q_p} \quad (28)$$

and the resistance area per passenger is, from (7) and (10),

$$\left[\frac{F_p}{H u_f} = \right] \frac{F_p q_p}{u_f Q k_p} = \frac{15 k_F}{16 k_U} \frac{q_p}{(\gamma_a - \gamma_g) x_1 \cdot u_f \cdot k_p}. \quad (30)$$

This shows that the equivalent specific resistance area varies in inverse proportion to x_1 , to u_f , and to the difference between

γ_a and γ_g .

The latter would appear to show that rarefaction of the medium is unfavorable, but this is not so. It is true that this specific area increases as the air becomes more rarefied, but the absolute resistance (the actual force) remains unchanged, because the rarefied medium has a lower resistance.

First I take ideal conditions for use in (30): $k_F/k_U = 1$,

$q_p = 100 \text{ kg}$, $k_p = 0.1$, $\gamma_a - \gamma_g = 0.001 \text{ t/m}^3$, $x_l = 100 \text{ m}$, and $u_f = 50$.

Then the relative resistance area (in the form of a plane) is 0.19 m^2 . This appears to be a paradox; how can the force on a part of the airship and on the whole man be less than that on the surface

area of his body, which is several times larger than 0.19 m^2 ? The fact is that the passengers are enclosed in a gondola, whose shape is such that its resistance is quite small and in no case equal to the resistance of the human bodies it encloses. This shows why the surface area of the men is not involved.

The resistance area is even less for my largest metal airships, being about 0.019 m^2 per man, which is the area of a square plate of side less than 14 cm. This is a plate not larger than the palms of the hands.

Now I take a very unfavorable basis for determining the specific resistance from (30): $k_F = 1.4$, $k_u = 0.7$, $q_p = 100$, $\gamma_a - \gamma_g = 0.001$, $x_l = 50 \text{ m}$, $u_f = 14$, and $k_p = 0.1$. This gives 2.68 m^2 for the resistance area, which is fairly substantial. The result for the

largest airship is 0.134 m^2 , or about $1/8 \text{ m}^2$. In any case, given a vessel of sufficient size and perfection, the specific resistance area represents less resistance than does the human body not enclosed in a gondola.

This means that, if the passengers were obliged to produce all the power needed to produce the forward motion of the vessel they are flying in, they would have to produce much less energy than that needed to move with the same speed in the same medium independently ("by themselves, on their two legs").

In this motion of the man I neglect any resistance other than that of the air.

This can also be put as follows: if a man were to lose his weight, then on moving in air as does a bird (or as does a fish in water) he would have to produce far more energy to overcome the air resistance than is needed while moving at the same speed under normal conditions in the closed gondola of a properly constructed airship.

We also need the resistance area per hp (per 75 kg-m).

From (7), (10), and (15) we have

$$\frac{F_p}{u_f} : p = \left(\frac{1125}{16} \cdot \frac{k_F}{k_U} \right) : \{ u_f k_F E_n \cdot x_1 (\gamma_a - \gamma_g) \}. \quad (31)$$

Then we can also say that the resistance area as a ratio to the motor power is inversely proportional to the motor energy E_n or to the number of kg-m per sec they produce per kg of their weight.

We put $k_F/k_U = 1$, $\gamma_a - \gamma_g = 0.001 \text{ t/m}^3$, $x_1 = 100 \text{ m}$, $u_f = 50$, $k_m = 0.1$, and $E_n = 25$.

Then an airship equal in length to an ocean-going steamship gives, for ideal shape, $(F/u) : p = 0.005625 \text{ m}^2$, or about 56.2 cm^{2*} , which is the area of a square of side [less than 8 cm, or less than the area of the palm of the hand]. The horsepower equivalent to this small area may give it the high speed calculated above, of course.

The specific area comes out 10 times smaller for the largest metal airships, being 5.6 cm^{2*} , which is the area of a square of side less than 2.4 cm^* .

For the unfavorable circumstances of an airship of displacement 6000 m^3 we put

$$k_F = 1.4; k_U = 0.7; u_f = 14; k_M = 0.1;$$

$$E_n = 25; x_1 = 50; \gamma_a - \gamma_g = 0.001 \text{ [t/m}^3\text{]}.$$

*Slips of the author's have been corrected; these overestimated the air resistance by a factor 10.

Then the formula gives 0.08 m^2 for the specific resistance area, while for the largest metal dirigibles it is 0.004 m^2 , which is equivalent to a square of side 0.063 m , or 6.3 cm .

It would seem that the specific resistance area per horsepower for an average airship under ordinary conditions is slightly more* than the resistance of a clothed man.

Now consider the resistance of the surface of the gasholder per passenger or per unit work of the engines. The friction on the shell in a properly designed airship will be about half the total resistance of the shell (or about $1/4$ of the total resistance of the vessel).

The specific surface area thus expresses the resistance of the airship. The surface area of the shell is

$$\frac{8}{3} \pi y_1 x_1 k \left(1 + \frac{2}{5} \cdot \frac{y_1^2}{x_1^2} \right), \quad (32)$$

in which k is a correction coefficient close to one. Dividing this area by the number of passengers as given by (13) and (10), we have

$$\frac{5}{2} \cdot \frac{k_a}{k_U} \cdot \frac{75}{k_M} \left(1 + \frac{2}{5} \frac{y_1^2}{x_1^2} \right) \cdot \frac{1}{(\gamma_a - \gamma_g) y_1}. \quad (33)$$

*Much less.

This shows that the relative area is inversely proportional to the size (y_1) and to the density of the medium.

$$\text{We put: } \frac{k_a}{k_u} = 1, k_m = 1/8, y_1/x_1 = 1/7, \gamma_a - \gamma_g = 0.001 \text{ t/m}^3,$$

and $y_1 = 7 \text{ m}$ to get the specific surface area as 216 m^2 (the area of a square of side 14.7 m , or about 7 sajene).

This surface experiences friction on one side only. If we picture this area as that of a plane moving along its length and subject to friction on both sides, we get roughly the total resistance of the shell (because this is twice the friction alone); but we should not forget that such a surface taken alone has more resistance than it does when it forms part of the whole shell.

This surface area is 20 times smaller for the largest airships and so is about 10.8 m^2 , the area of a square of side 3.3 m , which is not very great.

Alternatively, we can represent this area as that of a cube, whose side is given by (33) as of length about

$$\sqrt{\frac{5k_a \cdot 75}{12k_U (\gamma_a - \gamma_g) y_1}}. \quad (34)$$

This gives us 6 m for an ordinary airship and 1.34 m for the largest. The area is thus comparable with that of a high room in the first case, while in the second it is not sufficient for the surface of a closed carriage. This shows that the specific surface of the shell is small, as well as the resistance being low.

We divide the surface area of (32) by the power of the engines as given by (10) and (15) to get

$$\frac{5}{2} \cdot \frac{k_a}{k_U} \left(1 + \frac{2}{5} \frac{y_1^2}{x_1^2} \right) : \left\{ \frac{k E y_1 (\gamma_a - \gamma_g)}{M n l} \right\}. \quad (35)$$

Taking $E_n = 20$, and otherwise the same conditions, we have for an airship of displacement 6000 m^3 that per km-m of work* there is $1/7 \text{ m}^2$ of surface area, or 10.8 m^2 per steam horsepower (75 kg-m). The friction on such an area is very slight, so it is clear why an airship can move with a high independent speed. The area falls to 0.33 m^2 per steam horsepower for the largest size of airship. The volume of light gas per passenger is found from the above as

$$\frac{75}{(\gamma_a - \gamma_g)k_M} \quad (36)$$

This shows that the specific volume is not dependent on the size of the airship, being governed solely by the weight (75 kg) of a passenger, by the density difference $\gamma_a - \gamma_g$, and by the passenger coefficient k ($= k$).

We put $k = 1/8$ and $\gamma_a - \gamma_g = 0.001 \text{ t/m}^3$ to find the specific volume as 600 m^3 (volume of a cube of side 8.43 m). The giant airship has no advantage over midget dirigibles in this respect.

*Power.

XV. HEATING OF LIGHT GAS AND ADJUSTMENT OF LIFT*

1. This question of heating the light gas is very complicated; no exact theoretical solution is really possible in the present state of the art.

The combustion products from the motors are sent through a black pipe located within the shell and surrounded by the light gas (the heating pipe is now supposed to lie at the bottom, but this hardly alters the results).

The gaseous combustion products may be very hot (up to 500°C) if they are not mixed with air. This heat they give up to the black pipe, but its temperature is far from being the same at all points.

At the inlet it reaches nearly the temperature of the combustion products (500°C), but the temperature steadily falls towards the outlet. It is very difficult to account for the heat transferred to the gas by the various parts of the pipe.

The pipe must be made of a suitable material, of course (e.g., copper), and the wall thickness should be appropriate to the temperature. The pipe is best made to be of maximal radiative power; the state of the surface has a marked effect on this. For instance, it is good for the surface to be matt and black. Part of the heat from the combustion products is transferred to the light gas, and this part is the larger the higher the initial temperature of the combustion products; but the light gas will not have the same temperature in all parts of the shell.

The shell's temperature will also vary from part to part and will not be equal to the mean gas temperature. The composition of the gas is important, as are any contaminants such as dust, smoke, water vapor, or water mist. Of course, these contaminants may not be present, and this might even be better; but I believe that the mist and smoke in the Mongolfier balloons tended to retard the loss of heat from them and so tended to extend their time of flight, although they damaged the spheres.

Radiative cooling of the Earth is retarded by the clouds, so smoke and mist within the shell should tend to retain the heat in the airship.

The heat of the shell is transferred to the air; here the surface state of the shell is important, as is the opposing airstream

*Power.

when the airship is in motion.

The wind affects the cooling when the airship is at rest; the air temperature, sunshine, cloud cover, atmospheric transparency, height of the locality, and so on, all affect the heat loss.

The conditions are clearly complicated, but I shall make an attempt to derive an approximate solution for the heating of the airship by the combustion products.

The power of the engines is given by the usual formula; the equivalent quantity of heat is

$$aU \cdot k_m \frac{E_n}{M_e},$$

in which the factor M_e is the mechanical equivalent of heat, a is the density difference (between air and gas), U is the volume of the gas, k_m is the part of the upthrust assigned to the motors, and E_n is the energy produced per unit mass per second.

Let u_m be the fraction of the heat from the fuel that is converted into mechanical work by the motors; the total heat from the fuel is

$$\frac{aU k_m E_n}{M_e u_m}.$$

The amount of heat entering the black pipe is

$$aU k_m \cdot \frac{E_n}{M_e} \cdot \left(\frac{1}{u_m} - 1 \right).$$

Not all of this heat is taken up by the light gas; only a part u_t is, because the gases escape from the pipe into the atmosphere at a temperature above that of the surrounding air.

The heat reaching the contents of the airship is thus

$$aU k_{m n} \cdot \frac{u_t}{M_e} \left(\frac{1}{u_m} - 1 \right).$$

2. The amount of heat escaping with the gas into the atmosphere is dependent on the surface area S of the black pipe, on the temperature t_1 of the combustion products, on the flow speed and amount of

these, on the state of the surface of the pipe, and on the surrounding gas.

The heat lost by a hot body (temperature t_1) in unit time to a surrounding medium at temperature t_2 can be deduced from various formu-

las and studies. A very small temperature difference (10-20°) allows us to use Newton's formula (rate of loss of heat proportional to temperature difference).

This law can be applied to the cooling of the shell in the air, because the shell will only be slightly heated relative to the air.

In all cases it is assumed that the heat loss is roughly proportional to the surface area S , although the shape of the body also has an effect, strictly speaking.

Newton's law then gives us for the loss of heat per unit time

$$KS (t_1 - t_2),$$

in which K is dependent on the state of the surface and on the properties of the surrounding medium. This K itself has two parts: one arising from radiation (this is more dependent on the state of the

surface) and the other from loss by conduction and convection (this is more dependent on the properties and motion of the surrounding medium).

The first (according to Péclet) is $K_1 = 0.000000588$ for a tinned surface; it is very small for polished metal surfaces generally, but is 15 times larger for rusty iron, for example (0.0000089; second, dm^2).

Walerius gives the other as $K_2 = 0.000009$, not more (for a body placed with an atmosphere outside it). This shows that the first is 10 times less than the second for polished surfaces, but the two become comparable for black surfaces.

K is thus not more than 0.00001 for unpolished surfaces.

The cooling rate of the shell is thus

$$0.001S (t_1 - t_2),$$

in large calories per sec if S is in m^2 .

3. This formula is in no case applicable to the black pipe, because K increases rapidly with temperature.

Dulong and Petit's law can be applied for temperature differences up to 300° ; this expresses the heat lost by unit surface as

$$a (b^{t_1} - b^{t_2}) + c (t_1 - t_2)^{1.233}.$$

The first term relates to radiative loss, with $b = 1.0077$ always but a dependent on the state of the surface. The second term relates to heat lost by contact with the medium and has no factor affected by the state of the surface.

4. The first term can be neglected for highly polished metal

surfaces and not very large temperature differences; the heat loss is then that of a body in the open air:

$$0.001 (t_1 - t_2)^{1.233}.$$

This formula is more accurate than Newton's; some (Lorentz, Tereschin) have even used

$$0.001 (t_1 - t_2)^{1.25},$$

which is not very different.

5. These simplified formulas cannot be applied to black surfaces, or at high temperatures (above 300°C), especially when the two occur together, because the radiative loss becomes large and even exceeds the loss from other causes.

The ratio of the radiative loss to the other losses is given by (3) as

$$\frac{a (b^{t_1} - b^{t_2})}{c (t_1 - t_2)^{1.233}}.$$

Here $a = 0.1445$, $b = 1.0077$, $c = 0.0009$. For a black surface (e.g., scaled iron) with $t_1 = 300^\circ\text{C}$ and $t_2 = 0^\circ\text{C}$ we have the ratio (using the Péclet and Walerius coefficients) as 1.4, so the radiative

loss is rather more than the other losses.

Here we may replace the previous formula by the following one for convenience in comparing the two forms of loss:

$$\frac{161}{t_1^{1.233}} (b^{t_1} - 1).$$

Temperature t_2 has been taken as zero; then $t_1 = 1$ gives the ratio as 1.24 (losses nearly equal).

Other values are as follows: 100°C 0.635, 10°C 0.76, 50°C 0.61, and 600°C 6.1.

This shows that the radiative loss from a black surface is the dominant loss for small temperature differences; it then becomes relatively smaller but later rises: to 1.4 at 300°C, and subsequently indefinitely. Draper found that Dulong and Petit's formula is quite incorrect at high temperatures (above 800°C), and it is good only for temperatures up to 300°C.

6. I propose a formula that is not only simple but that appears also to be most probable.

This is Stefan's law for radiative heat loss:

$$a (T_1^4 - T_2^4),$$

in which T is absolute temperature.

This formula was supplemented by Lorentz [see (4) and (5)]:

$$a (T_1^4 - T_2^4) + c (T_1 - T_2)^{1.25},$$

in which the second term represents loss by conduction and convection. Stefan's formula gives a very likely temperature for the surface of the Sun and for the mean temperature of the Earth.

Boltzmann has given a theoretical derivation of Stefan's law.

Stefan and Christiansen found that $a = 12 \times 10^{-12}$ (sec, m², kcal).

7. The ratio of radiative loss to other losses is

$$\frac{a (T_1^4 - T_2^4)}{c (T_1 - T_2)^{1.25}}$$

8. $a/c = 1.22 \times 10^{-8}$; the ratio is 0.532 for $T_1 = 273 + 100^\circ$ and $T_2 = 273^\circ$, which is almost as from (5) (Dulong and Petit's formula). The result for a temperature difference of 300° is 1.00, which is also close to the result from Dulong and Petit's formula. For $T_1 = 873^\circ$ and $T_2 = 273^\circ$ (600° difference) the ratio is 2.35, which is much less than the 6.1 given by their formula.

9. The above ratio may be put as follows for temperature differences exceeding 500° :

$$\frac{a}{c} \cdot \frac{T_1^4}{(T_1 - T_2)^{1.25}}$$

Comparison of Dulong and Petit's formula with Stefan and Lorentz's

formula shows that the latter formula indicates less loss than the first for high temperatures; this agrees with Draper's measurements. The Stefan-Lorentz formula is therefore preferable for high temperatures.

10. The heat lost per second in kcal may be taken as $0.0025(t_1 - t_2)^{1.25}$ or $K_h S(t_1 - t_2)^{1.25}$ if the pipe has a temperature between 0 and 400 to 450°C, in which K_h is the heat-transfer factor, S is surface area in m^2 , and t_1 is in °C (first formula). In fact, I have taken the two forms of loss as being equal at some temperatures, which is true for 0 and 300°C.

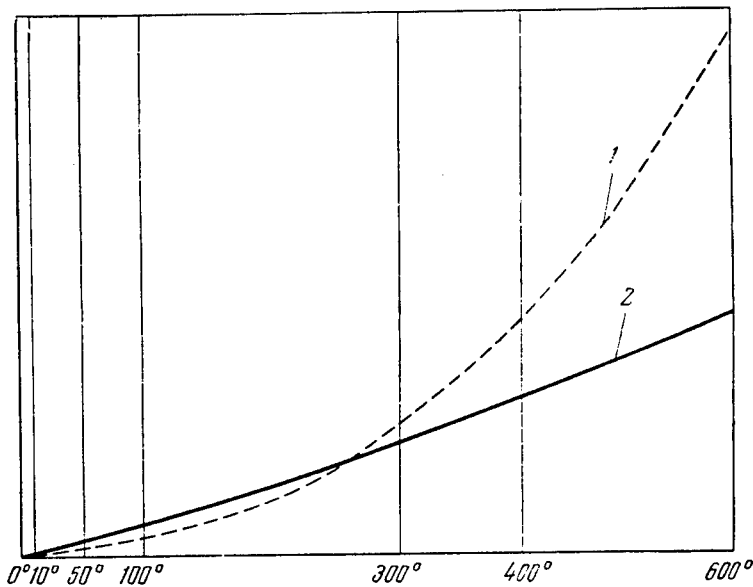

Fig. 1

Radiation by a black surface: 1) true (Lorentz);
2) assumed here and in accordance with loss by
conduction and convection.

The radiative loss is the smaller between these two temperatures, so the simplified formula gives a larger number of heat units; but above 300°C this formula gives a value lower than the true one, so the errors in part balance out.

Fig. 1 shows that the areas under the curves are nearly equal if the maximum temperature of the combustion products is 400°C.

11. Then for the polished surface of the shell, neglecting radiation, we have $0.001S(t_1 - t_2)^{1.25}$, with twice this for the black pipe. This gives the heat lost (kcal) in time τ (sec) from a surface S (m²).

12. Fig. 2 indicates the symbols used in the deduction of the fall in temperature along the black pipe.

The differential for the loss in a length dL for a pipe of radius r is

$$\pi r^2 \cdot dLc\gamma dt = 2\pi r \cdot dLK_h (t - t_3)^{1.25} a\tau,$$

in which c is the mean thermal capacity of the combustion products, whose density is d ; t is the temperature at a point on the pipe, t_3

is the temperature of the light gas, and τ is the time from the start of the motion of the combustion products in the pipe [see (11)]. The variables are separated and the equation is integrated to give

$$\frac{2cd\tau}{K_h \sqrt{t - t_3}} + \text{const} = \tau.$$

We have $t = t_1$ for $\tau = 0$, so this gives us the constant; then

$$\tau = \frac{2}{K_h} \cdot c\gamma r \left(\frac{1}{\sqrt[4]{t - t_3}} - \frac{1}{\sqrt[4]{t_1 - t_3}} \right).$$

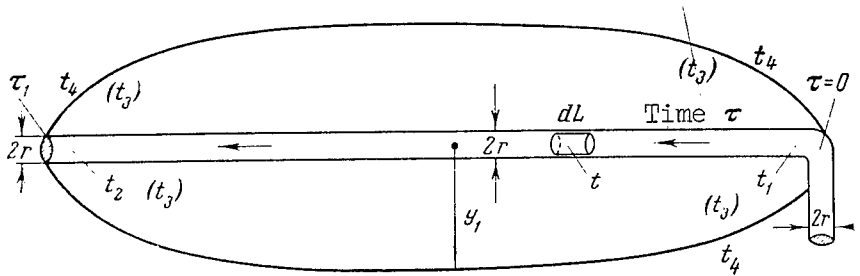

Fig. 2

13. With $\tau = \tau_1$ we have $t = t_2$, in which τ_1 is the time at which the gases escape from the end of the pipe and t_2 is the temperature at which they leave.

Now

$$\tau_1 = \frac{2}{K_h} \cdot c\gamma r \left(\frac{1}{\sqrt[4]{t_2 - t_3}} - \frac{1}{\sqrt[4]{t_1 - t_3}} \right),$$

so

$$t_2 = \left\{ 1 : \left(\frac{\tau_1 K_h}{2c\gamma r} + \frac{1}{\sqrt[4]{t_1 - t_3}} \right)^4 \right\} + t_3.$$

This gives us t_2 (temperature of escaping combustion products) if we know the initial temperature t_1 , the temperature t_3 of the light gas, and the transit time τ_1 of the products.

This time is now considered.

14*. We have seen in (1) that the amount of heat brought into the black pipe per second is

$$(aU) k_m E_n \left(\frac{1}{u_m} - 1 \right) : M_e,$$

or, from (13) of Chapter XIV,

$$\frac{16\pi}{15M_e} \left(\frac{1}{u_m} - 1 \right) k_u k_m a E_n v_1^2 x_1 = q.$$

15. On the other hand, this quantity q is equal to the volume U_p of the products leaving the motors per unit time multiplied by the specific heat c of these, and also by the density γ and temperature difference $t_1 - t_4$, in which t_4 is the air temperature; then

$$q = U_p c \gamma (t_1 - t_4).$$

These last two equations readily give the volume of products per second; the time of transit through the pipe is

$$\tau_1 = \frac{\pi r^2 L}{U_p},$$

namely the volume of the pipe divided by the volume of the products. We put $L = 2x_1$ to get from these equations that

$$\tau_1 = \frac{15}{8} \cdot \frac{M_e c \gamma (t_1 - t_4)}{k_u k_m a \left(\frac{1}{u_m} - 1\right) E_n} \cdot \left(\frac{r}{y_1}\right)^2.$$

16. We eliminate τ_1 from (3) to get

$$t_2 = \left\{ 1 : \left[\frac{15 M_e r (t_1 - t_4) K_h}{16 k_u k_m a E_n \left(\frac{1}{u_m} - 1\right) y_1^2} + \frac{1}{\sqrt[4]{t_1 - t_3}} \right]^4 \right\} + t_3.$$

17. The temperature t_3 of the light gas is essentially unknown, but it can be deduced. Our formula is applicable to the case in which t_3 differs little from t_4 (temperature of outside air), and we can put that $t_3 = t_4$.

It is also applicable when the black pipe is in the open air. The basis for the equation for t_3 is that the heat loss from the black pipe in the steady state is equal to the heat loss from the surface of the shell. The latter can be found if we know the surface temperature, but this is far from being t_3 , being much less. For example,

my experiments of about 1890 (on the cooling of a polished vessel in a room, with heat supplied at the center, as in an airship) gave a coefficient of $1/3000$ for 1 m^2 in a second.

On the other hand, the formulas given here imply (a denominator) about half this ($1/1500$ for closed buildings, or 0.001 for an open space).

This implies that the temperature difference between shell and air even in my experiments with the small model (20-30 cm; I cannot remember exactly) was half the mean temperature difference between the internal gas and the air.

Of course, the parts of the gas near the hot tube in a large airship will be at a much higher temperature than parts near the cold shell, and the temperature of these latter will be much less than the mean temperature t_3 of the gas.

I therefore take the heat-loss coefficient for the shell as K_h/n , in which n is a fairly large number available only from experiment. For example, my calculations on the old-fashioned Montgolfier balloons show that even here the heat loss from the dark surface was only half that in my experiments with a polished surface. Therefore $n > 8$, at least.

18. The heat lost by the polished surface of the shell is then

$$(2A_1 k_a) \left(\frac{K_h}{2n} \right) (t_3 - t_4)^{1.25},$$

in which K_h is the normal heat-loss coefficient for a polished surface, as in (10); t_3 is the mean temperature of the light gas, and $2A_1 k_a$ is the surface area of the shell.

19. Now I turn to the heat lost by the black pipe. The amount of heat given by the pipe is known from (1) and (4), in which u_t is the proportion transferred to the interior of the balloon,

which is

$$u_t = \frac{t_1 - t_2}{t_1 - t_4},$$

in which the numerator is the change in temperature of the combustion products escaping from the pipe and the denominator is the excess temperature (above the air temperature) of the gases entering the black pipe.

20. This means that the equation we need is

$$2A_1 k_a \frac{K_h}{n} (t_3 - t_4)^{1.25} = aU \frac{E_n}{M_e} \left(\frac{1}{u_t} - 1 \right) \left(\frac{t_1 - t_2}{t_1 - t_4} \right) k_m.$$

We eliminate $2A_1$, aU , and t_2 to find that

$$(t_3 - t_4)^{1.25} = B \left\{ t_1 - t_3 \frac{1}{\left(A + \frac{1}{\sqrt[4]{t_1 - t_3}} \right)^4} \right\},$$

in which

$$B = \frac{1}{\left(1 + \frac{2}{5} \frac{y_1^2}{x_1^2} \right)} \frac{0.4n}{t_1 - t_4} \left(\frac{1}{u_m} - 1 \right) \frac{k_u}{k_a} \cdot \frac{k_m}{M_e} \cdot \frac{E_n}{K_h} \cdot a \cdot y_1$$

and

$$A = \frac{15 \cdot K_h M_e r (t_1 - t_4)}{16 \cdot k_u k_m a E_n \left(\frac{1}{u_m} - 1\right) y_1^2}$$

21. It is now simple to deduce t_3 if the sizes of shell and black pipe are known; and with t_3 we can deduce t_2 from section 16 (this is the temperature of the products leaving the black pipe).

22. We calculate A and B for $n = 10$ (because the present airships are larger than the Montgolfier balloons); $t_4 = 0$, $t_1 = 400$, $u_t = 0.1$, $k_u/k_a = 1$, $k_m = 0.01$ (which means that the motors account for only a hundredth part of the upthrust aU), $a = 0.001 \text{ kg/dm}^3$, $K_h = 0.001$ (per m^2 per sec, half that for the black pipe), $E_n = 25 \text{ kg-m/kg}$, $y_1 = 15 \text{ m}$, $(1 + 2y_1^2/5x_1^2) = 1$, $M_e = 424$, $k_u = 1$, $r = 25 \text{ cm}$, and $K_h = 0.002$ (for a black surface, as in section 10).

Then $A = 0.157$ and $B = 0.7960$.

23. From (21) we have

$$t_3 = \frac{B \left[t - \frac{1}{\left(A + \frac{1}{\sqrt[4]{t_1 - t_3}} \right)^4} \right] + t_4 \sqrt[4]{t_3 - t_4}}{B + \sqrt[4]{t_3 - t_4}}$$

24. To determine t_3 roughly I assume that the heat lost by the shell is proportional to $t_3 - t_4$; then from (16)-(21), discarding the power 1.25, we have

$$t_3 = \frac{B \left[t_1 - \frac{1}{A + \frac{1}{\frac{4}{\sqrt{t_1 - t_3}}}}} \right] + t_4}{1 + B}.$$

The quantity under the root sign is only very slightly dependent on t_3 , so we can put $t_3 = t_4$, provided, of course, that t_1 is large relative to t_3 .

For example, if we assume that t_4 (air temperature) is zero, we have $t_3 = 160^\circ\text{C}$; inserting this in the exact formula of (23), we get $t_3 = 62^\circ\text{C}$. Proceeding in the same way with 62°C , we get $t_3 = 78.27^\circ\text{C}$. The fourth approximation gives $t_3 = 75.86^\circ\text{C}$, so the mean temperature of the light gas is about 76°C .

25. We halve the radius of the pipe to give $r = 12.5$ cm ($2r = 25$ cm), so $A = 0.0785$ and $B = 0.796$, from (22). A rough estimate of t_3 may be made by using the exact formula with $t_3 = 76^\circ\text{C}$ in

the second part, because the surface area of the pipe does not have a very great effect on the gas temperature if this area is not changed too greatly. This gives $t_3 = 62^\circ\text{C}$.

The third approximation is $t_3 = 64.5^\circ\text{C}$, so we can take 63 - 64°C

as being quite adequate for practical purposes.

26. We have used $t_4 = 0^\circ$ in the above calculations, in which case (23) is replaced by

$$t_3 = \frac{B \left[t_1 - \frac{1}{\left(A + \frac{1}{\sqrt[4]{t_1 - t_3}} \right)^4} \right]}{B + \sqrt[4]{t_3}}$$

27. Formula (16) provided us with t_2 , the temperature of the gases leaving the pipe. Using (20), we put (16) as

$$t_2 = \left\{ 1 : \left(A + \frac{1}{\sqrt[4]{t_1 - t_3}} \right)^4 \right\} + t_3.$$

The conditions of (24) give us roughly that $t_2 = 39 + t_3 = 115^\circ\text{C}$, while for the pipe 2 times narrower we have $t_2 = 106 + t_3 = 170^\circ\text{C}$.

28. We have from (23) with $t_4 = 0$ that

$$t_3 = \left(\frac{B}{1+B} \right) \cdot \left\{ t_1 - \frac{4}{\left(A + \frac{1}{\sqrt[4]{t_1 - t_3}} \right)^4} \right\},$$

which shows that t_3 increases with A (i.e., as n , K_h , and r increase) and with B (as K_h decreases), as in (20).

The relation of t_3 to the other independent variables is not explicit. A will be large if $k \frac{E}{m n}$ is small and t_1 is large, so the factor within the braces can be neglected.

Then we have in place of the above that

$$t_3 = \frac{B (t_1 + t_4)}{1+B},$$

which shows that t_3 increases in proportion to t_1 and also with B (i.e., as $k \frac{E}{m n}$ and y_1 increase); the increase in t_3 with y_1 (height of shell) is particularly worthy of attention.

29*. The temperature regulator provides adjustment of the temperature of the light gas between t_3 and t_4 ; t_3 can be much higher than the values calculated above, because we assigned only 1% of the over-all upthrust to the motors. The gas temperature can readily reach 100°C or more [see (28)] if this proportion is increased; as regards the temperature of the combustion products, the pipe can be made narrower as this temperature rises, and so the limits of temperature variation for a given motor power are made wider.

The principal reason for heating the gas is to alter the upthrust of the airship.

The relative change in this is the ratio of the volumes of a fixed mass of gas at temperatures t_3 and t_4 , namely

$$\frac{273 + t_4}{273 + t_3} = \frac{T_4}{T_3}.$$

For instance, if $t_4 = 27^\circ\text{C}$ and $t_3 = 127^\circ\text{C}$, we have $T_4:T_3 = 0.75$, which means that the lift of the cooled airship is only $3/4$ of that of the airship with the gas heated (reduction by a quarter of the initial value).

These calculations seem to me to show that a difference $t_3 - t_4$ of 100°C across the shell could be readily maintained. This has the very important practical consequence that the airship can set down a load equal to $1/4$ of the total upthrust $U\gamma_a$ while retaining its equilibrium and even descending if necessary.

One quarter of the total upthrust $U\gamma_a$ is about 3 times the total weight of all the passengers.

More precisely, it is larger by a factor $1/4k_p(1 - \gamma_g/\gamma_a)$, because

$$Uak_p = U(\gamma_a - \gamma_g)k_p.$$

Putting

$$k_p = 0.1 \frac{\gamma_g}{\gamma_a} = \frac{1}{12},$$

we have $2 + 8/11$. The airship can descend to the ground, discharge all the passengers plus a cargo twice their weight, and go on its way empty. Then it arrives in some city, takes on a full complement of passengers and a vast cargo, and then continues on its way without need to top up with gas.

30. Another reason for adjusting the upthrust is to provide means of rapid or slow ascent or descent without loss of gas or ballast, and also to avoid meteorological disturbances that could upset the vertical equilibrium.

For instance, the heating of a black shell by the Sun's rays could (under favorable conditions) increase the upthrust by $1/10$ of the initial value. This mighty effect of the sun can be avoided only by altering the upthrust via an opposing change in the temperature of the light gas, namely reduction by means of the regulator.

I neglect here the methods of releasing gas or ballast, for these cannot long serve the purpose.

31. The change in upthrust is governed by the temperature change of the light gas. For a fixed air temperature,

$$dQ = Q_i \frac{dT_g}{T_g}.$$

For instance, consider a gas temperature $T_g = 300^\circ$ and $dT_g = 1^\circ$;

then the change dQ will be $1/300$ of the initial upthrust Q_i . This

means a change of 1 ton in response to 1°C change if the upthrust is 300 tons, so each degree rise enables the vessel to take on 10-15 more passengers, and conversely.

32. Further advantages are that the heated gas is drier and less dense (less mass for the same volume), and so is cheaper.

33. Of course, the upthrust will be larger, since the gas is also more readily heated.

34. The heating of the gas and shell warm up the whole airship, which tends to keep dry and not to rust; for the same reason, snow falling on it will melt and trickle away, and so will not reduce the upthrust appreciably, even in cold polar countries.

35. Also, the slow motion of snow in conjunction with the fast forward motion of the airship will mean that the relative motion of the snow is nearly horizontal, so in the limit the amount of snow striking the shell will be reduced (relative to that with the ship at rest) in the ratio of the transverse cross-sectional area to the lengthwise one (namely, by about a factor seven for a given elongation of the shell).

Alteration of the upthrust can also provide forward motion with the airship in an inclined position.

36. Now I consider the time needed to cool or heat the airship sufficiently; if this is too large, the method (of heating the gas to adjust the upthrust) cannot be considered satisfactory.

Section 1 gives the heat received by the gas from the black pipe when the inflow and outflow of heat have come to equilibrium:

$$aUk \frac{E}{m} \frac{u}{n} \left(\frac{1}{u_t} - 1 \right) : M_e.$$

The airship loses this amount of heat through its shell in the same time.

To heat the entire mass of gas through 1°C requires

$$U \gamma_g c_p,$$

in which γ_g is the density and c_p is the specific heat at constant

pressure. We can take $\frac{\gamma c}{g p}$ as roughly constant for any gas that may fill the shell, so we may say that the result will be the same whether it is filled with air or pure hydrogen.

In one second the gas is heated or cooled by

$$\frac{a k E_n}{M \gamma c e g p} \cdot u_t \left(\frac{1}{u_m - 1} \right).$$

We assume that the loss or gain of heat is proportional to time during this unit time.

We know u_t (proportion of heat taken from black pipe) is known from (19) as

$$u_t = \frac{t_1 - t_2}{t_1 - t_4}.$$

37. Here we put $a = 0.001$, $k_m = 0.01$, $E_n = 25$ kg-m/sec, $M_e = 424$ kg-m/kcal, $\gamma_a = 0.0012$, $c = 0.24$, $u_m = 0.1$, $t_1 = 400^\circ\text{C}$, $t_4 = 0$, and $t_2 = 170^\circ\text{C}$ (black pipe 25 cm in diameter; see sections 25 and 27); then

$$u_t = \frac{23}{40}.$$

The change in a second is thus 0.01057°C , or in a minute 0.6342°C . Heat loss from the shell has the same effect.

38. The rise in unit time will be greater than that calculated if the airship is still cold, because the loss of heat from the shell will be negligible, since its temperature is close to that of the air. We may therefore take t_3 (gas temperature) as 64°C , since the heating to about $t_3/2$ will be roughly proportional to time, and the rise in τ minutes will thus be $0.6\tau^{\circ}\text{C}$.

This formula may also be used to express the cooling of the shell. More exact calculations could be performed, but the work involves numerous formulas, and it is sufficient here merely to have a general conception of the rates of heating and cooling.

39. The above sections indicate how long is needed to heat the light gas through 27°C ; $0.6\tau = 27$, so $\tau = 45$ min.

This means that not less than 45 min would be needed for the heated airship to cool by 27°C after the hot gas has ceased to pass through the black pipe. This cooling will be accompanied by loss of 0.1 of the initial upthrust, in accordance with (31).

It needs $3/4$ hr to cool the shell after the temperature regulator has shut off in order to set down all the passengers and cargo; also, to take on a full complement of passengers after this needs not less than 45 min in order to heat the light gas via the black pipe.

40. But these times are not to be reckoned as unalterable; they can be greatly reduced, for (36) shows that the heat loss or heating per unit time is governed by $k_m E_n$, i.e., by the power of the airship's engines.

If, for example, the motors are assigned (for the same energy) not 1% of the total upthrust but 10% ($k_m = 0.1$), we have a heating

coefficient 10 times larger, which means that the rise in temperature in a minute can be 6°C . The takeoff thus requires not 45 min but $4-1/2$ min, which is almost instantaneous. Heating of quite adequate rate would be provided by increasing the power of the motors by only a factor three, for then the heating time for 27°C change would be only $1/4$ hr.

The heating coefficient of (36) is not dependent on the size of the airship; no matter how large the airship may be, the heating (heating rate) is not thereby reduced.

2. ELEMENTARY DESIGN OF A METAL DIRIGIBLE *

I. Description of the drawings

The drawings are schematic, i.e., the scale may vary even in the same drawing.

Fig. 1. This figure depicts the metal envelope of the dirigible in the flattened state. It has not yet been filled with gas and is suspended by chains in a special dock. It has the shape of a flat-bottomed boat stood on edge, with the deck covered over. The sides of the dirigible, consisting of corrugated iron sheet, are fitted with vertical, flexible, but comparatively massive bands, which also serve as a means of connecting the lateral corrugated-metal trapezoids. The top and bottom of the envelope consist of long, narrow curved surfaces reinforced by massive cross members and flexible longitudinal beams. The ends of the envelope, i.e., the stern and the bow, are square.

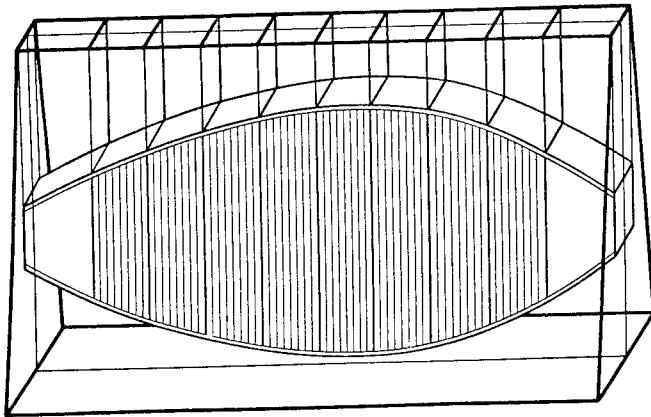

Fig. 1.

*1914.

From a distance it is only possible to distinguish the two corrugated side walls of a large natural-size dirigible; the other parts are comparatively so small that they can scarcely be seen; in general appearance the dirigible resembles a willow leaf.

The curved lines running fore and aft indicate the half-cylinders that cover the articulated joints.

Fig. 2. The same envelope, but in the inflated state. In its natural form it is the same shape as a giant spindle. The blunting of the ends is discernible only at close range.

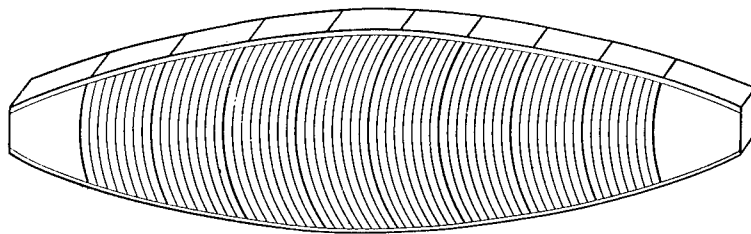

Fig. 2.

Fig. 3. Transverse vertical section through the uninflated envelope.

Fig. 4. Same, through inflated envelope.



Fig. 3.

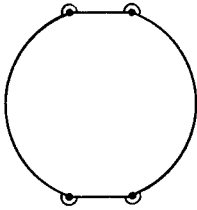

Fig. 4.



Fig. 5.

Fig. 5. Same, but with air inside envelope evacuated. It is in this form that the envelope is filled with gas.

In all of these drawings (Figures 3, 4, 5), the black dots indicate an articulated joint between the sides and the top and bottom of the envelope; the incomplete circles, on the other hand, represent sections through the tubes that cover these joints and thus prevent the gas from leaking out.

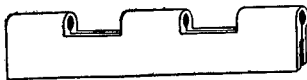

Fig. 6.

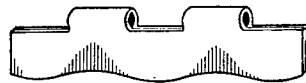

Fig. 7.

In the case of real envelopes, these tubes will not be visible at a distance.

Figures 3 and 5 then assume the form of two vertical panels with an almost imperceptible gap between them, while Figure 4 appears like a smooth circle.

Fig. 9 shows the articulated joint between the corrugated

side panels and the top or bottom.

Figures 6, 7, and 8 show the principal elements of the metal envelope of the dirigible.

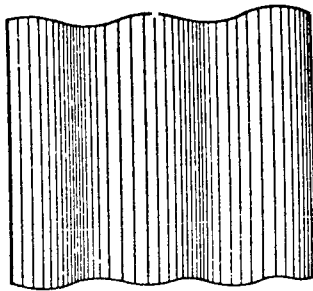

Fig. 8.

The leaves of the hinge (Figures 6 and 7) are made by factory methods, in unlimited lengths and in standard form. Their thickness depends on the size of the envelope.

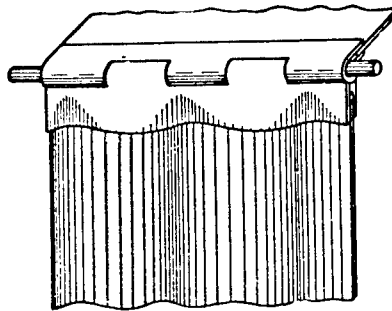

Fig. 9.

The part shown in Fig. 6 is in contact with the narrow strip at top or bottom, and the part shown in Fig. 7 is in contact with the corrugated side wall; for this reason it has a corrugated cross section into which the corrugated side wall (Fig. 8) or a part of it -- a trapezoidal panel -- fits.

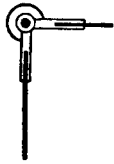

Fig. 10.

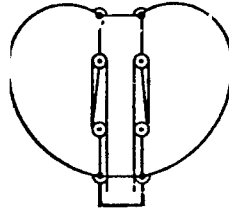

Fig. 11.

Fig. 10. Cross section through an articulated joint covered by a gastight flexible tube.

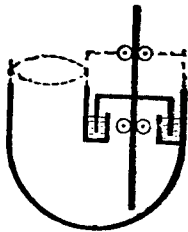

Fig. 12.

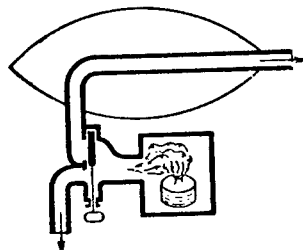

Fig. 13.

Fig. 11. Transverse vertical section through an elementary

type of dirigible. The gondola is attached at the bottom.

The envelope is held under tension by a block and tackle system to stabilize the longitudinal axis in a horizontal position.

Fig. 12. Safety valve in the bottom of the envelope -- in the gondola. Gas from the envelope fills the broad tube on the left.

If the pressure exceeds the norm, then the gas will lift the slide valve, like a stove damper, and the valve flange will rise out of the liquid filling the annular channel so that the gas can escape freely, thus reducing the excess pressure inside the envelope. The action of the valve is facilitated by rollers.

Fig. 13. This drawing is a graphic illustration of how the gas temperature inside the envelope is changed. It shows the temperature regulator.

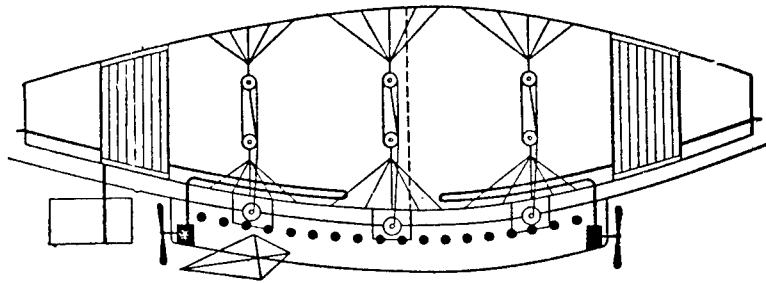

Fig. 14.

The combustion products from the dirigible's engines are directed into a pipe, whence one fraction is conveyed through the interior of the envelope in a black metal tube, heating the light-weight gas inside the envelope, and the envelope itself, in the process, and is then vented to the outside. The remaining fraction is directed into an exhaust pipe and vented directly into the atmosphere.

The manually operated slide valve controls the amount of gas flowing in either direction by covering and uncovering the openings

leading to the black tube and the exhaust pipe, respectively.

The two openings are usually partially covered, so that a certain average temperature, say 30°C , is constantly maintained inside the envelope; by moving the valve one way or the other, this temperature can be reduced to zero (the temperature of the air) or raised to 60°C .

Fig. 14*. The metal dirigible and its principal components. Only a portion of the corrugated metal surface is shown. Most of it has been cut away.

Inside the envelope we see the pulley tensioning system designed to insure the stability of the longitudinal axis of the dirigible.

Beneath this, in the bottom of the envelope, we note the two black tubes leading from the gondola engine, through the temperature regulator (Fig. 13), and forming a duct for the hot combustion products.

The tubes begin at either end of the gondola, where the engines are located; the propellers are also found here. The outlets of the black tubes are at either extremity of the envelope. The two tubes make it possible to control the buoyancy of the two halves of the envelope independently. This is a highly efficient means of restoring the horizontality of the longitudinal axis of the dirigible. The temperature difference between the front and rear sections of the envelope is also due to the presence of a light, but strong and flexible transverse diaphragm (with a rhombic mesh) indicated by the broken line. It need not necessarily be rubberized and may allow the gas to pass, but only very slowly. This is the only inflammable part of the dirigible; it can not burn in hydrogen, of course; in any case it is not an absolute necessity.

On the left-hand side of the gondola we find the control surfaces: a horizontal control surface (a distorted rhomb) and a vertical one. The total area of the control surfaces must be large enough to include the stabilizers.

A non-reacting passive stabilizer, such as a rudder or a bird's tail, for changing the direction of the dirigible would be a burden; it would be 10 times less efficient in restoring the trim or proper direction of the dirigible than rapid-acting automatic control surfaces of the same area.

This is why I am against fixed stabilizers*.

What are the advantages of this design?

Block-and-tackle tensioning at various points along the gondola will compress the gas and insure a stable longitudinal axis. Tensioning at one end combined with relaxation at the other will tilt the longitudinal axis, or make it possible to restore a tilted axis to the horizontal. The same effect can be achieved much more easily by

means of the two temperature regulators (Fig. 13).

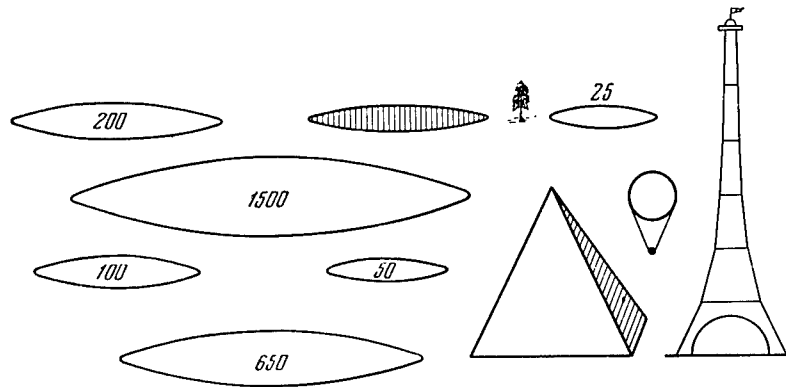

Fig. 15.

Pulling the middle of the diaphragm in one direction or the other may serve the same purpose.

The temperature regulators operating simultaneously and in combination enable the dirigible to rise, sink, and vary its buoyancy without loss of gas or ballast.

The normal pressure level inside the envelope is restored by tightening or loosening the envelope, as the gas volume and pressure change in response to a rise in altitude or other factors.

If this were not done, the intensified gas pressure could be relieved by means of the various safety valves (Fig. 12) installed to valve off excess gas. This, of course, could only happen in the event of negligence, which there is no reason to anticipate.

A catwalk makes it possible to inspect not only the bottom but also the top of the envelope, even while aloft.

Fig. 15. The relative size of various dirigibles as compared with the Eiffel Tower, the Pyramid of Khufu (Cheops), the deck of an ocean-going steamship (shown hatched), a pine tree, and Giffard's captive balloon.

The figures indicate the number of passengers carried.

Fig. 16*. All-metal models of the dirigible made exclusively of iron. This, so to speak, is the first embodiment of the idea.

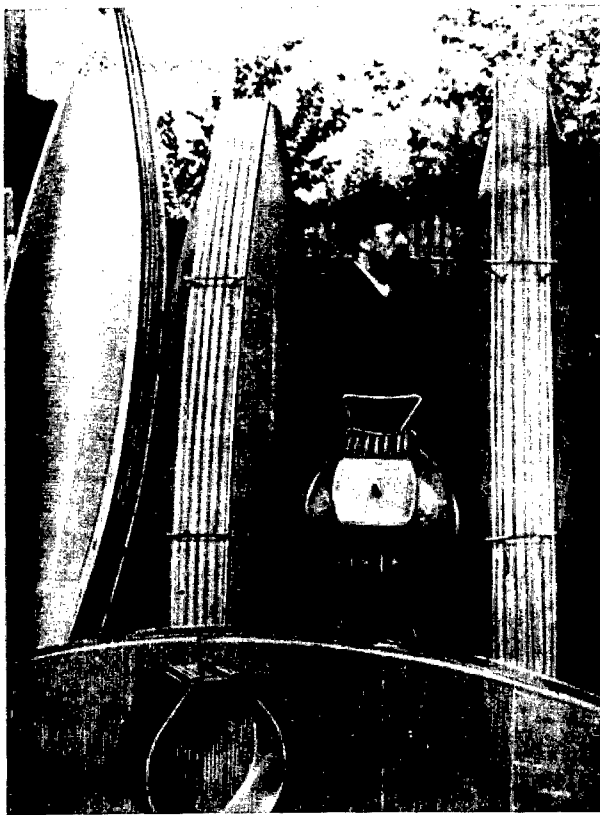

Fig. 16.

In the middle we see a flat dirigible, at the bottom a slightly convex, and at the top the fully inflated form. The half-tubes used to cover the articulated joints at the edges of the envelope show up clearly.

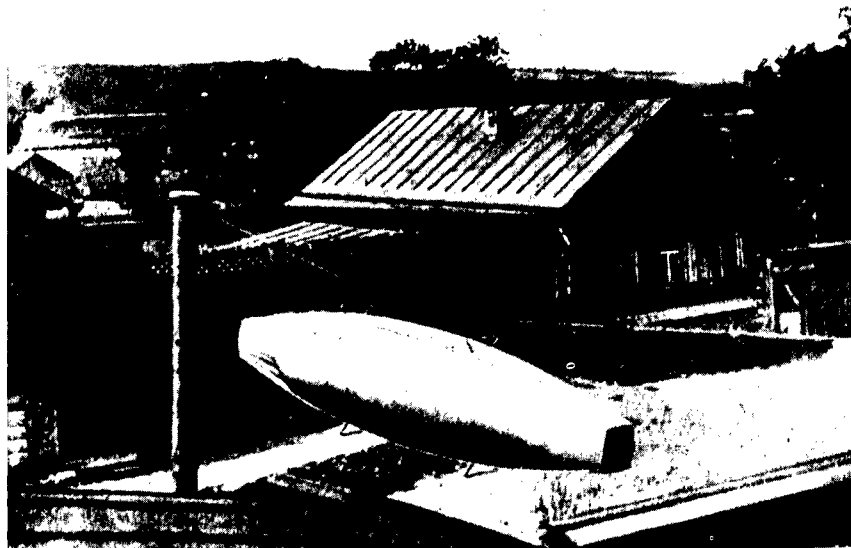

Fig. 17.

The envelope personally constructed by
K. E. Tsiolkovskiy during the years 1912
and 1913.

Fig. 17. The inflated dirigible in its most distinctive form.
The bottom, not visible, is exactly the same as the top.
The length of each model is about 2 meters.

II. ADVANTAGES

1. Incombustibility. There is nothing inflammable --
neither in the envelope nor in the gondola, except for certain furnish-
ings. The gas will not explode by itself, though it will burn. If a

multiplicity of small openings were made in the envelope and the escaping gas were to catch fire accidentally, we would get a series of steady flames burning outward, since the internal pressure would not permit air to penetrate into the envelope; this means that there would be no mixing and hence no explosion. Of course, the envelope itself will not catch fire, but at worst may melt, the most serious mishap being the loss of gas. The envelope will slowly collapse, losing some of its buoyancy in the process. On board ordinary dirigibles, the passengers, and in particular the pilots and crew, being more responsible, are continually anxious about the possibility of fire breaking out. Smoking and lighting fire is strictly prohibited. Actually, a minute is all that is required to bring complete disaster and reduce the ship to ashes. Terror and panic paralyze the hand and mind. The gas could ignite unexpectedly due to a spark caused by friction or atmospheric electricity. It is very difficult to foresee and forestall such mishaps. The slightest confusion on board, some misunderstanding, and the crew may lose their heads and contribute to a serious accident.

2. Impermeability of the envelope, absence of osmosis. There is no danger of losing buoyancy. Storms, hurricanes, whirlwinds, foul weather and no opportunity to land are not such terrible threats. All of this can be overcome by rising higher into a quieter layer of the atmosphere, where there is always good weather and the sun shines imperturbably, and where at night the course is indicated by the stars, the moon, compass, barometer, and other instruments.

The ship can stay aloft as long as desired at these altitudes, and, of course, it is perfectly safe to descend under more favorable weather conditions and at some place more favorable for landing. Let the stormy weather rage on below, we can spend our time leisurely in the kingdom of bright light and pure air. There will be no harm even in stopping the engines.

3. Nonhygroscopicity of metal. Thanks to this property, the dirigible will not become heavy and weighted down by absorbing moisture from the air or rain.

4. Life of dirigible. Aluminum, nickel, and many other metals will last a century without being replaced; the same holds for an iron envelope periodically coated with varnish or paint. A lead-plated envelope is also tough. The envelope may be made twice as thick as sheet iron in large dirigibles, or 6 times as thick (3 mm thick) when aluminum is used. The properly constructed metal envelopes of large dirigibles would be virtually indestructible.

5. Cheapness of iron. Fabric rubberized on one side is not only 50 times more expensive but, what is more important, ruptures easily under the action of sun, weather, and fire. Because of the short life of this material, it turns out to be at least 1000 times more expensive than iron. And how attractive is the prospect of cutting the costs of a dirigible by 1000 times!

6. The strength of the material makes it possible to build dirigibles 300 meters high, each capable of carrying as many as 200,000 passengers. Such dirigibles could travel faster than railroad trains. Travel on board these vessels would be cheaper than transportation on board a steamship, since (cf. my "Simple study of an airship") everyday all-weather travel by airship would be accessible to one and all.

7. The bright surface of the metal envelope will absorb little heat from the sun and will not be cooled so readily by radiation at night, or in the daytime when heavy clouds cast their shadow over the dirigible.

A consequent change in the temperature of the light gas inside would necessitate both valving off gas and releasing ballast. This loss will in general be greater than that due to osmosis of the gas. It will be minimized, of course, if a metal envelope is used.

8. Heating of the light gas. Actually, a metal dirigible should never have to lose gas and ballast at all thanks to the artificial increase and change in the temperature of the gas inside the envelope. It would be dangerous to heat the gas unless the envelope were noncombustible. The combustion products from the engines are led through a special black metal tube located inside the envelope. The cooled products are expelled from this pipe into the atmosphere. Accordingly, the light gas is always heated above the temperature of the surrounding air. If a fraction of the combustion products is vented directly to the outside air, then the temperature inside the envelope will be lower. In other words, the temperature of the light gas can be varied within certain limits, which brings a host of advantages following from the use of a metal envelope, viz.:

- a) high temperatures to increase the buoyancy;
- b) no risk of water or snow freezing and sticking to the envelope in wintertime or in polar regions;
- c) varying the temperature also makes it possible to regulate the buoyancy of the dirigible over an enormous range; for

example, all the passengers or all the cargo could be discharged, yet the dirigible, thanks to artificial lowering of the temperature of the gas, would not tend to shoot upwards into the clouds like a rocket;

d) varying the buoyancy makes it possible for the dirigible to ascend and descend with no loss of gas or ballast;

e) for the same reason, the dirigible will find it easier to cope with natural fluctuations in the gas temperature due to sunlight and other factors; for instance, when the gas is heated by the sun, the temperature can be artificially lowered, and the tendency of the dirigible to float upwards counteracted.

9. No need for ballonet. In order to preserve its external shape with change in altitude, position, etc., the ordinary dirigible carries inside a gas bag (ballonet), partially inflated with air. As a result, the soft surface of the dirigible remains smooth, and deep folds, that might interfere with control of the dirigible in flight, do not develop. But a metal dirigible cannot develop folds, its shape is consistently true and well adapted to cutting through the air, and thus it has no need to carry a ballonet inside. The ballonet might still prove useful for maintaining longitudinal stability; but this can be achieved just as well by tensioning the corrugated envelope.

Should this tensioning prove inadequate for the needs of large metal dirigibles, recourse could be had to other means of maintaining stability (Fig. 11 and Fig. 14). I have written extensively on these means, and they are now being used in the latest designs (Crocco and Torres-Quevedo).

10. The model I have constructed demonstrates that a completely elastic dirigible can be obtained even when the height is no more than 2 meters. Theory shows, however, that even a dirigible as tall as the Eifel tower (300 meters) could be built. In view of the feasibility of small dimensions, we can begin by constructing a tiny dirigible. We then risk very little, and in the process we can learn how to build dirigibles of more generous dimensions. Thus, we shall be in a position to take our second step with virtual certainty of success.

11, 12. Huge envelopes are made possible by the strength and low cost of iron and steel. Their size will render metal dirigibles the cheapest means of transportation for passengers and cargo, as I have proved many times over in my writings. The speed

of the zeppelin is now 75 km/hr; the speed of large metal dirigibles will be twice as great, i.e., in no way inferior to the speed of airplanes.

13. Ease of inflation. With the envelope suspended in the dock in its flattened-out form, the air is evacuated. The envelope will contract, the walls will draw closer together to the point of contact, and only at top and bottom will a small amount of air remain. Then light gas is admitted at the top while air is still being exhausted from the bottom, until the air is completely replaced by hydrogen. More hydrogen is then pumped in, all the other openings in the envelope being sealed (Figures 1, 2, 3, 4, 5).

14. The volume of the envelope will vary elastically from almost zero to some specific value. The smoothness of the shape will not be impaired in the process. If the dirigible were filled to half its maximum capacity at sea level, then, assuming it contains no internal ballonet, it would be capable of ascending to a height of 5 km with no trouble. Because of the state of tension of the corrugated envelope, the stability of the longitudinal axis will always be secure. Its ability to move through the air will not suffer either. A metal dirigible could thus make its way over mountainous areas, over any plateau. There would be no barriers to its progress.

15. Gondola, propellers, rudders, and stabilizers remain to be added to our design for a metal dirigible. The two heavy longitudinal bands at top and bottom are convenient for this purpose. The cabins could be both underneath and on the roof, and the same holds for the propellers, so that the protection and maneuverability of the dirigible would be greatly increased. The dead and live loads of the lower gondola would have to be much greater than those on top, for reasons of stability.

16. There would be no need to use expensive and dangerous gasoline as fuel. The engines could burn the envelope gas. If this were ordinary illuminating gas, the fuel would be 10 times cheaper than gasoline; but if pure hydrogen were used, it would still not be more expensive than gasoline. As the gas inside the envelope was used up, the interior of the envelope would have to be heated by the method described. When the temperature of the gas could no longer be raised any higher, the dirigible would have to be lowered to the ground, the gas cooled, and the envelope refilled. Then the dirigible would be ready for another thousand kilometers of nonstop flight.

17. Simplicity of construction. An assembly dock is needed, i.e., a huge barn with the upper longitudinal strip suspended from the ceiling. Then the side walls are hung from the roof strip. These side walls are similar and consist of trapezoidal panels. Each panel is installed separately in the same hangar, from below, on a horizontal or inclined platform. The trapezoids are made of corrugated iron sheet (Fig. 8). The corrugations are uniform for each and every trapezoid. The non-parallel sides of the trapezoids have hinges at top and bottom (Figures 6, 7, 9, 11), matching those of the upper and lower beams. The parallel sides of the trapezoids are designed to form leaktight joints; these joints are closed after the wall panels have been joined to the roof strip. The bottom of the envelope is joined to the wall panels later on. Finally, all the hinged joints are covered with cylindrical half-tubes (Figures 3, 4, 5, 6, 10) to prevent leaks. The attachment of the gondola, propellers, etc., presents no problems. I may add that everything will definitely be made of metal (Fig. 14). Note that all the parts are first joined geometrically, and only later are the joints sealed.

18. Risk to life and limb. The zeppelin-type dirigible may be considered a very safe means of transportation, except for its inflammability. It would be even safer than my proposed vessel, if it were made entirely of metal, but this would be impossible without a radical change in design.

Actually, if all the light gas were to be let out of a zeppelin, it would still retain its external shape, the hydrogen being replaced by air. This shape, having a considerable surface area, would prevent it from falling too quickly; the partially deflated dirigible would act somewhat like a parachute.

My dirigible lacks this advantage, unless air were blown into the ripped envelope by means of a large emergency fan.

But the inflammability of the material cancels out all the advantages of existing dirigibles.

3. THE DESIGN OF A METAL DIRIGIBLE TO CARRY FORTY PASSENGERS

In this chapter I shall give a far from perfect and quite incomplete account of the design of a dirigible 20 meters high and 120 meters in length, capable of carrying 40 persons, and having a volume not exceeding 23,600 cubic meters.

It is still premature to think of actually carrying out this project. Much preliminary work will be required, as shown in my article "Sequence of Practical Operations in the Construction of Dirigibles" (see Chapter V). Once these preliminary steps have been taken, the project could be carried through to completion in line with the results obtained.

Moreover, a project involving a dirigible of this size could not be very successful in any case: the larger the dimensions (up to a height of roughly 50-100 meters), the better the prospects of realizing the project.

I. Design Fundamentals

The design of this dirigible is based on four principles that are not applicable to other systems.

1. It is made entirely of metal (a cheap, durable, and strong material). There are no gas losses. It has a long life.
2. Variability of volume without detriment to the smoothness of the shape, strength, or durability of the envelope. Simple design.
3. Construction of the envelope on a horizontal surface in flat form.
4. Inflation with hydrogen in the same position, without first having to raise the envelope.
5. No construction dock or hangar.
6. No need for a mooring tower, since the dirigible, lacking

a rigid framework, is elastic like a ball. A small mooring mast will do.

7. No need for ballonets or bulkheads. These are replaced by a cable tensioning system.

8. Heating of the interior of the envelope by means of combustion products and natural cooling eliminate ballast and gas losses.

Thanks to the above advantages, the lift force can be varied at will. Meteorological effects can be dealt with successfully. Option of changing altitude, at no cost, in order to escape from rainstorms, thunderstorms, pitching and rolling, and to take advantage of favorable winds.

9. Simplicity in design and ease of construction.

10. All the loads are suspended. All the forces place the envelope, and other parts of the dirigible, in tension, the condition of minimum weight.

11. The gondola, motors, cargo, etc., are all suspended and have their support (thanks to an ingenious system of cables) in the vast upper surface of the envelope.

12. The rigid part of the dirigible, the floor of the gondola, serves as a firm foundation for mounting essential equipment.

13. The elastic limit of the material should not be exceeded at any point.

14. On the whole, the dirigible is flexible, and the less flexible parts are relatively small.

15. The rest of the design is the same as for other dirigibles. This applies to the motors, propellers, and control surfaces.

Most of the calculations are approximate, but on the conservative side. For example, the forces and the weight of the equipment are exaggerated, while the lift force is underestimated.

II. Some Theoretical Remarks

Some previous acquaintance on the part of the reader with my writings on the metal dirigible is assumed. Accordingly, I shall not go into too great detail. Much will be taken for granted. My aim is a practical one: to point out the best design and best way to build it. I shall present the simplest and most practical formulas, without going into detailed explanations.

Shape of Longitudinal Section of Dirigible Envelope

16. From my "Theory of the Aerostat" (I shall refer only to formulas from that work), it is clear that the principal longitudinal section through an envelope filled with hydrogen may be expressed by the equation (259):

$$y = y_1 \cdot \left(1 - \frac{x^2}{x_1^2}\right)^{3/4}.$$

This is a very smooth curve, as may readily be seen from the drawings. The corresponding surface of revolution is not quite so full (blunt or convex) as an ellipsoid, but is fuller than the surface formed by rotating a parabolic curve (taken at the vertex).

17. On inflation, a flat envelope of this shape will require corrugations of constant curvature (in the middle section), which simplifies the construction of a corrugated metal dirigible. Only the ends of the envelope will require steeper corrugations.

In order to avoid this, the ends of the envelope are replaced

with conical surfaces.

Nevertheless, these should still be corrugated, though the corrugations may be shallower, because smooth (even conical) surfaces will form irregular folds on inflation. And this would jeopardize the stability of the envelope.

The Role of the Envelope Bases

18. These bases are necessary, for in large dirigibles it is the bases that resist most of the gas pressure. But since they cannot be very broad, they must be made three times as thick and of equally strong material. Moreover, thanks to the bases the bending of the side walls of the envelope will be the less the closer we come to the ends, which is precisely what is called for, since the depth of the corrugations is almost constant, and the radii of curvature of the side panels diminish toward the ends of the envelope.

19. Note that even these thick bases, by enlarging the volume of the envelope, increase the lift force by as much as the weight of the envelope is increased as a result of adding to the bases themselves.

The bases, therefore, must not be made narrower toward the ends in order to save weight; they should rather be made thinner toward the ends and thicker toward the middle. The middle could also be enlarged without being made thicker. This would not only increase the strength, but improve the buoyancy of the dirigible and is therefore more advantageous than thickening.

Slope of the Envelope Corrugations

20. A rough idea of the stretching of the corrugations may be had from formula (294). Using the notation of Fig. 1, we find

$$\frac{S - S_1}{X_2} = 0.5 \cdot \frac{Y_2^2}{X_2^2}$$

21. Here Y_2/X_2 is the slope of the corrugations, $(S - X_2)/X_2$ is the ratio of the total extension to the unstretched sheet. The total depth of the corrugations will be $2Y_1$, and the total length $4X_2$. The ratio will be $0.5 Y_2/X_2$, i.e., one half the slope of the corrugations.

22. The curve of the corrugations may be an arc of a circle, a truncated sinusoid; or even a straight line. I recommend a smooth curve, as for example an arc of a circle. Of course, the stretching will also depend on the shape of the cross section, but only very slightly: the error will not be large, and we may assume that our formula is valid for all curves provided the slope X_2/Y_2 is not greater than 0.5.

23. The corrugations must not be flattened out completely. After the envelope has been inflated and the corrugated sheet subjected to a certain amount of stretching, shallow or gently sloping corrugations must still remain. Otherwise, the rigidity of the envelope will be impaired, and failure may even occur. If the corrugations remain, failure will be impossible (the longitudinal bases will prevent it).

24. For this case, using the notation of Fig. 1, we find from the formula derived above, cf. (20), that

$$\frac{S - S_1}{X_2} = 0.5 \left(\frac{Y_2}{X_2} \right)^2 \cdot \left[1 - \left(\frac{Y_3}{Y_2} \right)^2 \right]$$

Here Y_3/Y_2 is the relative residual slope of the corrugations after the corrugated sheet has been stretched*; $(S - S_1)/X_2$ is the maximum, but not the total relative extension of the corrugated sheet. When the corrugations are completely flattened, we get the limiting extension of the corrugated sheet.

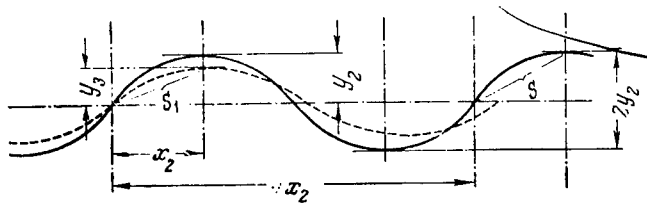

Fig. 1

25. I shall now turn to the inflation of the dirigible envelope, i.e., the transition from the plane condition to a surface of revolution.

Using the notation of Fig. 2 for the dimensions of the dirigible, we have (259):

$$\frac{A_1}{dx} = \frac{3\pi^2}{32} \cdot \left(\frac{y_1}{x_2}\right)^2 \cdot \frac{\left(2 - \frac{x^2}{x_1^2}\right)}{\sqrt{1 - \frac{x^2}{x_1^2}}},$$

*I.e., the ratio of the residual slope (or, more precisely, depth) of the corrugations to the initial slope.

where A_1 is the increment in the arc of the horizontal meridian over an interval dx as the envelope passes from the flat to the inflated shape, and vice versa. In the latter case, the increment will be negative.

This applies to the section described above under 17.

26. I have shown that the extension will be about the same for different points on the center-line of the envelope (except at the ends), i.e., for different x/x_1 . In order to find this extension,

we put $x/x_1 = 0$ in the last formula. We then calculate

$$\frac{A_1}{dx} = 1.85 \left(\frac{y_1}{x_1} \right)^2.$$

Here x_1/y_1 is the aspect ratio of the fully inflated envelope.

27. This extension (25) must be equal to the extension of the corrugated sheet, see (24), i.e., from (26) and (24) we obtain

$$1.85 \left(\frac{y_1}{x_1} \right)^2 = 0.5 \left(\frac{Y_2}{X_2} \right)^2 \left[1 - \left(\frac{Y_3}{Y_2} \right)^2 \right].$$

Remember that y_1/x_1 is the aspect ratio of the inflated envelope, and Y_2/X_2 is the slope of the unstretched sheet, while Y_3/Y_2 is the residual slope of the corrugations after the dirigible has been inflated.

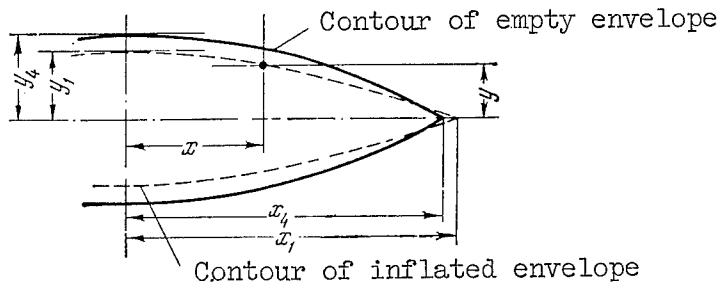

Fig. 2

28. From (27) we have

$$\frac{x_2}{y_2} = 0.52 \left(\frac{x_1}{y_1} \right) \sqrt{1 - \left(\frac{y_2}{y_1} \right)^2}.$$

This shape determines the slope of the corrugations of the unstretched corrugated sheet as a function of the envelope aspect ratio and the residual slope of the corrugations in the inflated envelope.

We design the envelope in the flattened form. It is assigned a certain aspect ratio. What will be the greatest slope of the corrugations? Neglecting the bases, we have:

$$29. \quad 2\pi y_1 = 4y_4,$$

where y_1 is the radius of the inflated envelope, and y_4 is the radius

of the flattened envelope. Eliminating y_1 with the aid of this formula, we have from formula (28):

$$30. \quad \frac{x_2}{y_2} = 0.817 \left(\frac{x_1}{y_4} \right) \cdot \sqrt{1 - \left(\frac{y_3}{y_2} \right)^2}.$$

31. Suppose, for instance, that the aspect ratio of the flat side walls of the envelope is four, and that the convexity of the stretched material is 0.5, i.e.,

$$\frac{x_1}{y_4} = 4 \text{ and } \frac{y_3}{y_2} = 0.5.$$

Then

$$\frac{x_2}{y_2} = 2.827.$$

In general, we can compile a table, such as Table 1 below, for different aspect ratios of the flat envelope, giving the slope of the corrugations for a residual slope of 0.5 and 0.3.

The last two rows of the table give the relative value of the total extension (straightening) of the corrugated sheet, or the degree of shortening of the flat metal surface upon corrugation. This shortening may amount to 11%, which is uneconomical. But there is no need to make dirigibles with an aspect ratio in the flattened form of less than 4 (or less than 6.3 when inflated). Then the shortening

TABLE 1

1. Aspect ratio of uninflated envelope	x_1/y_4	3	3.5	4	4.5	5	5.5	6
2. Aspect ratio of inflated envelope [cf. (29)]	x_1/y_1	4.7	5.5	6.3	7.1	7.9	8.6	9.4
3. Slope of corrugations for a residual slope of 0.5 (for uninflated envelope)	y_2/x_2	0.48	0.40	0.36	0.31	0.28	0.26	0.24
4. Reciprocal of slope for a residual slope of 0.5 (for uninflated envelope)	x_2/y_2	2.1	2.5	2.8	3.2	3.6	3.9	4.2
5. Same, but for a residual slope of 0.3	x_2/y_2	2.34	2.73	3.12	3.51	3.90	4.28	4.67
6. Extension of corrugated sheet when envelope inflated, %	$100 A_1/dx$	8.4	6.1	4.7	3.7	3.0	2.5	2.1
7. Limiting extension of corrugated sheet for a residual slope of 0.5	-	11.4	8.1	6.4	4.9	3.9	3.3	2.8
8. Same, but for a residual slope of 0.3	-	9.4	6.9	5.2	4.1	3.3	2.7	2.3

will not be greater than 6.4%. When the sheet is corrugated, it is possible to judge whether the slope is satisfactory from the shortening.

According to formulas (245), the extension of the envelope will be far less near the bases and will tend to zero. But some degree of corrugation must still be retained, even at the bases themselves, otherwise the side walls would not have the required rigidity. The corrugations may, however, grow shallower as the bases are approached. In view of the concavity of the upper portion of the envelope, the upper parts will stretch somewhat more than the lower parts. Therefore, it is even preferable to keep the depth of the corrugations at the top of the envelope almost the same.

32. From (245) we conclude that the shortening A as a function of the distance \bar{y} from the edges of the envelope may be expressed by the formula

$$A = A_1 \left(\frac{\bar{y}}{y_1} \right) \cdot \left(2 - \frac{\bar{y}}{y_1} \right),$$

where y_1 is the distance from the center to the edge of the flat envelope along its transverse diameter.

This formula can be used to compile a table of approximate values of the ratio A/A_1 for various relative distances to the edges of the envelope.

TABLE 2

\bar{y}/y_1	0.1	0.2	0.3	0.4	0.5	0.6	0.7	0.8	0.9	1
A/A_1	0.19	0.36	0.51	0.64	0.75	0.84	0.91	0.96	0.99	1

This table will be of greater value for very large dirigibles, whose fabrication must be more precise.

33. Elongated envelopes are more economical. Thus, we see clearly from Table 1 that in the case of a flat envelope with an aspect ratio of 5 (or almost 8 when fully inflated), the maximum shortening would be less than 4% (the true figure will be even less, since the envelope stretches).

34. The elastic extension of the corrugated sheet is given in row 6 of Table 1. For example, in the case of flat envelopes with aspect ratios of 4 and 5, the percentage extension must be 4.7 and 3. In the case of envelopes 2 meters or more tall with an aspect ratio of 5 when flat, this is perfectly feasible, as demonstrated not only by the many calculations I have made but also by my experience in building a model*.

The transverse elastic bending of the envelope during inflation is also feasible on the same basis (cf. "Theory of the Aerostat").

The practical conclusions that may be drawn from this discussion of the slope of the envelope corrugations are illustrated in Fig. 1.

III. Notes on Use of Table¹

35-40. The tabulated data relate to one half of the envelope. The purpose of the table is to elucidate the forces acting on the envelope. From these data we can also obtain some hints on improving the design of the dirigible. The table is also necessary for its construction.

Initially I have confined my remarks to the more important rows of the table.

Row 8. Needed in actual construction.

¹Table 3 at the end of this chapter.

Row 12. Dimensions of inflated envelope, vertical.

Row 15. Volumes of compartments, and total volume.

Row 16. Lift force for each compartment and dirigible as a whole (not counting weight of hydrogen).

Rows 17 and 18. Same, inflated to 75% capacity.

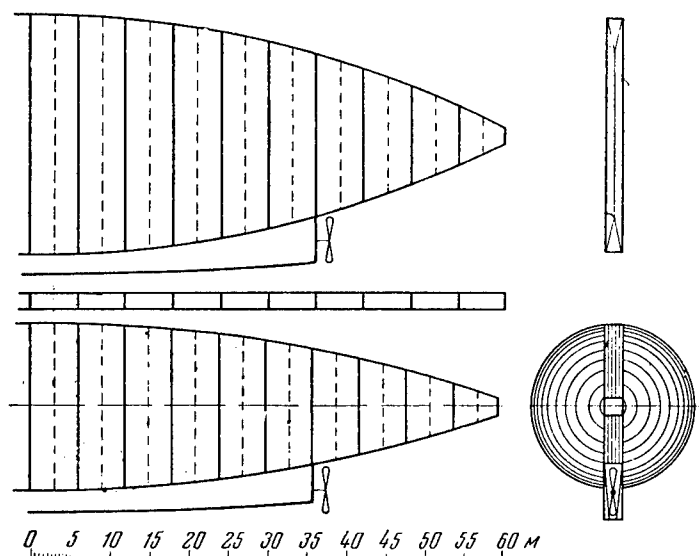

Fig. 3

Rows 34 and 35. Free lift force for compartments and dirigible as a whole (inflated to 100% and to 75% capacity), available to lift motors, control surfaces, fuel, passengers and crew, and other necessary loads.

Rows 36 and 37. Same, but not for a whole compartment, i.e., referred not to 6 meters but to 1 meter of length of compartment (or gondola).

Row 38. Overpressure of gas inside envelope, per square meter.

Rows 66 and 67. These figures must serve as a guide in determining the thickness, width, and strength of the bases at different cross sections.

41. Fig. 3 is also intended as an aid to understanding the table.

The upper part of Fig. 3 relates to the flat, and the lower part to the fully inflated dirigible. The upper diagram shows the dirigible in the vertical position (even though it may be constructed in the horizontal position).

The solid lines running across the diagram indicate planes normal to the longitudinal axis, which divide the envelope into imaginary compartments of equal width. There are ten of these, each 6 meters wide. The relative distance of the parallel sections from the center is not indicated in the drawing. The broken lines enclose imaginary trapezoids, of which the solid vertical lines form the axes. When the envelope is inflated, these trapezoids become conical surfaces.

The length of the longitudinal semiaxis of the envelope is denoted as x_1 , while x simply denotes the distance of the transverse plane from the center cross section. There follows a row by row description of the tables.

42. Row 1. This gives the ratio x/x_1 defining the position of the cross section.

Rows 2-4. These give the following quantities, which will be found useful in the calculations:

$$1 - \left(\frac{x}{x_1}\right)^2; \quad \sqrt{1 - \left(\frac{x}{x_1}\right)^2}; \quad \sqrt[4]{1 - \left(\frac{x}{x_1}\right)^2}.$$

Row 5. The relative ordinates of the flattened side walls of the envelope or

$$\frac{y}{y_1} = [1 - (\frac{x}{x_1})^2]^{3/4}.$$

Rows 1-5 are essentially only ratios.

Row 6. Tangents of angles for flat envelope.

Row 7. True distances of cross sections from the center cross section.

Row 8. Ordinates y of flat side wall, assuming the center ordinate y_1 to be 15 meters. This and subsequent values are computed

from the formula of row 5 only up to the tenth column (i.e., to the section 0.9). Actually, the design of the envelope calls for conical ends*. To obtain these, tangents to the surface of the envelope must be drawn from the point where $x/x_1 = 0.9$ (row 6).

Row 9. Double ordinates ($2y$) of the flat envelope (under construction), or lengths of cross sections.

Row 10. Same, with the addition of the width of the base, which I assume to be 2 meters (about 10% of the height of the inflated envelope).

Row 11. Ordinates of the completely inflated envelope, or radii of the cross sections. Divide the half-perimeter of the cross section of the flat envelope by π .

Row 12. Diameters of cross sections through inflated envelope. The ordinates and diameters differ from the values for a flat envelope in row 9 because of the bases, but only slightly.

Row 13. Cross-sectional areas of fully inflated envelope.

Note that rows 8-13 do not depend on the length along the longitudinal axis of the envelope. They relate to any aspect ratio (for a flat envelope 30 m wide).

Row 14. Suppose that the side walls of the flat envelope consist of trapezoids whose centerlines coincide with our cross sections. The figures in this row indicate the heights (widths) of these trape-

zoids when the length of the flat envelope is 120 meters (semiaxis 60 meters), or when the aspect ratio of the flat envelope is 4. The first and last figures relate to half-trapezoids. The heights are therefore also halved.

When the envelope is inflated, the trapezoids form, with the bases of the envelope, a series of truncated cones, whose heights will be nearly the same as those of the trapezoids. We obtain 11 new conical compartments. Only the end compartments will be halved.

Row 15. Here the figures indicate the volumes of the compartments when the envelope is fully inflated. We saw that the ends of the envelope must be conical. The last column is computed accordingly. Note that more exact formulas yield larger volumes for the cones and for the dirigible as a whole*. The volume of all 11 cones will be 11,795 cubic meters, double this value being 23,590 cubic meters. This is a comparatively small volume. Dirigibles are now being built with a volume 4 to 6 times larger and more.

Row 16. The lift force for each compartment fully inflated with hydrogen. The lift force per cubic meter is assumed to be 1.2 kg. The combined lift force for all 11 compartments is 14,149 kg, and the lifting capacity of both halves of the envelope together is 28,298 kg, i.e., more than 28 tons.

Row 17. Our dirigible is, in general, not filled to full capacity (100%) but rather to approximately 75% of capacity. This enables the dirigible to rise to almost 2 km, which is often advantageous, and sometimes necessary.

The figures in this row give the volume of the compartments assuming 75% inflation. The half-volume of the envelope is then 8,844 cubic meters, and the total volume 17,688 cubic meters*.

Row 18. But at this degree of inflation the lift force for each compartment will be reduced. Thus the lift force developed by all 11 compartments will be 10,612 kg, and the lift force developed by the entire dirigible will be 21,224 kg.

Row 19. Twice the area of the lateral trapezoids of the flat envelope. The area of the terminal rectangle (2.46×2) square meters is added to the end. The half area is 2,604 square meters, and the total area 5,208 square meters (Fig. 3).

Row 20. The weight of each pair of lateral trapezoids. We assume the density of the metal to be 7.8, and its thickness to be

0.15 mm, with 10% allowed for welding, corrugations, etc. Under these conditions, one square centimeter of sheet metal will weigh 1.3 kg. The half-weight will be 3,398 kg, and the total weight 6,796 kg.

Row 21. The weight of the bases of each pair of trapezoids. We assume the density to be 7.8; thickness 0.45 mm; the weight per square meter 3.51 kg. Adding 20% for the hinged joint, longitudinal (very shallow) corrugations, the inclination, etc., we find that one square meter of the base weighs about 4.2 kg. Note that the inclination of the bases, even at the ends, will increase their length by only 13%, while at this point they may be at least half as thick.

The area of the bases for each compartment, assuming a width of 2 meters, is computed in row 14. Multiplying this by the weight of one square meter, 4.2 kg, we obtain the figures in row 21. The weight of the bases for half the envelope will be 1000 kg, that for the entire envelope 2000 kg.

Row 22. The weight of each conical compartment with the bases and hinged joints. The weight of half the envelope is 4,386 kg, that of the entire envelope 8,772 kg.

Row 23. Surplus lift force for each compartment and 100% inflation (row 15). The combined surplus is 9,751 kg, that for the entire envelope 19,502 kg.

Row 24. Same, for 75% inflation (row 16). The combined surplus is 6,211 kg, that for the entire envelope 12,422 kg.

Row 25. The difference in the lift force for each compartment when inflated to 100% and when inflated to 75%, i.e., one fourth the total lift force or one third the partial lift force. We can obtain the total surplus more simply and more reliably by dividing the combined lift force (row 16) by 4. We thus find 3,532 kg, and 7,064 kg for the entire envelope.

In order to find the net lift force for each compartment, we have still to subtract the weight of the gondola, the cable tensioning system, the heating tube, etc. We shall now deal with these points.

Row 26. Here we determine the weight of the cable tensioning system: the total weight and the weight per running meter of the gondola.

The load on the cable system is not greater than the maximum lift force, i.e., 28 tons (row 16). The cross section needed to resist this load will not be more than 28 cm^2 , if we assume an ultimate strength of 60 kg/mm^2 and a factor of safety of 6; if the density is 7.8, one meter of cable will weigh 22 kg. On the average its length will be not more than 20 meters. This means that the entire cable system will not weigh more than 440 kg. Doubling this figure to allow for pulley blocks and miscellaneous parts, we arrive at 880 kg. This means about 12 kg per meter of the gondola (the length of the gondola being 72 meters).

Row 27. We now consider the total weight of the heating system per meter, assuming the heating tube to run the length of the gondola. We shall assume a semicircular cross section, diameter 0.5 meter, and a wall thickness of 0.13 mm. The surface area of the tube will be 57 square meters. It will weigh 57 kg. We double this figure and round off the result to allow for the temperature regulator and other accessories. We arrive at a figure of 120 kg, or 1.7 kg per meter.

Row 28. We now find the weight of the gondola hangers. The load on these members can not be greater than the maximum lift force (row 14). Therefore the cross-sectional area can not be greater than 28 cm^2 (row 26), and the weight per meter can not be greater than 22 kg. Assuming the average height of the gondola to be 4 meters, we obtain 88 kg. But in view of the need for transverse bracing and various other secondary members, we shall double this figure and round it off to 180 kg, or 2.5 kg per meter.

Row 29. We now deal with the sheathing of the gondola. The lateral surface area will be 57 square meters. Assuming steel or some other metal, one square meter of which weighs 1 kg, and rounding off, we obtain a figure of 600 kg for the side walls of the gondola. This includes the light windows and doors. Thus, we have about 9 kg per running meter of gondola.

Row 30. We now find the total and the relative weight of the gondola floor. We shall take the width of the gondola as 2 meters, the average thickness of the floor as 4 cm, and assume the structural material to be wood with a density of 0.6. Then the weight of the gondola floor per meter will be 45 kg. The total weight of the floor will be 3240 kg. How this load and the other loads are dis-

tributed will be clear from the drawings.

Row 31. Weight of suspended seating, bunks, etc. We may assume a weight of 10 kg per person or a total of 400 kg for all 40. This amounts to less than 6 kg per running meter of gondola.

Row 32. Thus, one running meter of gondola with seats, cable tensioning system, and heating tube, will weigh $12 + 2 + 9 + 3 + 45 + 6 \approx 75$ kg. The total weight over a length of 72 meters will be 5,544 kg*.

Row 33 gives the weight of the gondola compartments.

Row 34. From rows 33 and 23, we find the lift force for each compartment of the gondola and each section free of the gondola for 100% inflation.

Row 35. Same, but for 70% inflation (row 24). The last half-length compartment of the gondola is supported by a double (6 meters) envelope compartment, and for that reason the free lift force is comparatively high.

Row 36. Same, but per meter instead of for the entire compartment.

Row 37. Same, but for 75% inflation.

Row 38. If the gondola extended the full length of the envelope and the load were distributed according to the lift force for each compartment, there would be no forces tending to bend the dirigible, i.e., there would be no moment of the envelope and no moment of the lift force. More precisely, they would cancel each other out.

In this case the envelope would be subjected solely to the vertical tension due to the weight of the envelope and the pressure exerted by the gas. In row 38 we have the total gas pressure (difference) over each cross section. It is theoretically assumed that a tube open at the bottom (appendix), filled with hydrogen and one half the height of the envelope (10 meters) in length, is connected to the bottom point of the envelope. This tube will double the average gas pressure. Note, by the way, that the average pressure per meter will be 24 kg, maximum 36 kg, minimum 12 kg. Without the added pressure (i.e., without the tube), the minimum pressure would be zero, the average pressure 12 kg, and the maximum 24 kg. In general,

we have

$$p = (\gamma_{\text{air}} - \gamma_{\text{gas}}) (b + h),$$

where the difference between the density of the air and the density of the hydrogen (filling gas) is multiplied by the sum of the length of the tube and the distance from the low point of the envelope to the section in question.

Row 39. The relative value of the ordinates of the fully inflated envelope.

Row 40. Formula (468) gives us the ratio of the two components of this (gas) pressure which place the bases in tension. We shall neglect the stresses in the side walls.

Rows 41 and 42 present these components, i.e., the tension on the upper and lower bases.

In the case of large dirigibles, for example, dirigibles designed to carry 100 to 1,000 persons, the gondola will extend the entire length of the envelope, and the moments of the free lift force and the force of gravity will balance out. We shall be dealing principally with the gas pressure. Then, as is evident from the last two rows of the table, near the middle the tension on the upper base will be almost 1.3 times greater than that on the lower base. In giant dirigibles, therefore, the middle portion of the upper base must be made thicker and broader. The latter will be more economical, since it will increase both the volume and the lift force of the envelope.

In general, however, and particularly for the case of small dirigibles, it will be quite difficult to balance the gondola load against the free lift force of each compartment. Actually, the ends of the envelope, since they carry neither the gondola nor any other load, create a moment of the lift force acting to compress the upper base and stretch the lower one. Likewise, the appreciable weight of the motor creates a moment with the opposite effect on the bases. The heavy objects sometimes transported on board dirigibles may also have a harmful effect on the bases. Thus we may have to deal with envelope and lift force moments that are not balanced with respect to any of the compartments of the dirigible.

Suppose, for instance, that at the beginning of its trip the dirigible is filled with hydrogen, and that the surplus lift force is one fourth the maximum. This surplus is utilized by some load placed at the midpoint of the dirigible. Consider the consequences of this set of circumstances. First, we must determine the separate lift force moments for each compartment, then the total moment, and, finally, the effect of this moment on the envelope. Row 25 gives the surplus lift force for each compartment.

Row 43. Distance of the compartments from the center cross section of the envelope.

Row 44. Multiplying the surplus lift force (row 25) of each compartment by the distance (row 43), we find the individual moments about the center cross section. These are given in row 44. The sum of the moments about the center cross section is 74,182 kg-meter.

Row 45. In the same manner, we can find the moment of the lift force about the second cross section and about the remaining cross sections, and the sum of these moments about any individual cross section. But there is an even simpler way of determining this. Each moment about the second cross section is reduced by the sum of the remaining lift forces multiplied by its distance from the center cross section (3 meters).

Row 46. In this way we can find the sum of the moments about any cross section. To do this, we first add to each figure in row 25 the sum of all the succeeding figures. We thus obtain row 46.

Row 47. We now find the product of these figures and the distances (row 43).

Row 48. Finally, by subtracting the figures in row 47 from their counterparts in row 45, we obtain the total moments about each cross section. In the first box, we have two moments: one about the center cross section, and the other about the cross section nearest to the center cross section, at a distance of about 3 meters (see: "Theory of the Aerostat"); the moment formulas are (394), (395), (396). Then formulas (397) - (399) and (442), (449), and (450).

Rows 49-52. What moments acting on the bases will balance these lift force moments at each cross section? We can determine the unknown additional (equal and opposite) forces on the bases at each cross section from the equation $zy + zy = M$, or $z = M/2y$, where z is the unknown force on the base, y is the radius of the cross section

of the inflated envelope, given in row 11; M is the sum of the lift force moments from row 45. From these data (rows 49 and 44), we compute the additional forces acting on the bases (row 50). Comparing these figures (row 50) with the forces on the bases due to the gas pressure (rows 41 and 42), we see that the tension on the lower base must increase drastically, while the tension on the upper base will be reduced, since the latter is placed under compression (rows 51 and 52).

This is how matters stand when the load is concentrated at the center of the dirigible. Then the strength of the upper base will be wasted, while the lower base will have to be made twice as thick. This is all disadvantageous. In particular, it is uneconomical from the standpoint of minimizing weight, which is a basic concern in designing flying machines.

We shall now assume that the permissible load of 7,064 kg (row 25) is located at the ends of the envelope. We have 3,532 kg at each end.

The surplus lift force will tend to raise the ends of the envelope; the end loads, on the other hand, will tend to force the ends down. To what extent the two moments balance each other out may be seen from the calculations.

Row 53. This gives the distance of the end of the envelope (or load) from each cross section.

Row 54. In this row, we compute the moment of the half-load (3,532 kg) about each cross section, i.e., we multiply 3,532 kg by the distance from the load to the cross section, making use of row 53.

Row 55. We determine the additional force z acting on the bases from the equation $2zy = M$, or $z = M/2y$. We find the values of z with the aid of rows 54 and 49.

On comparing the figures thus obtained with the forces (row 50) due to the surplus lift force, we see that the latter is far from smoothed out by the end loads; the serious imbalance remains.

Clearly, the gondola loads must be as evenly distributed as possible, according to the lift force for each individual compartment. Nevertheless, the force acting on the upper base (closer to the center cross section) will be slightly greater than that acting on the lower base, which is not only uneconomical, but also dangerous in large dirigibles where the safety factor is small. Failure of the upper base would be more hazardous than failure of the lower one.

Row 56. The result of the combined action of the end loads

(row 55) and the lift force (row 50) is expressed by a positive change in the forces acting on the bases of the envelope, as indicated in this row.

Rows 57 and 58. On comparison with the tension due to the gas pressure (row 51), we see that there is a marked increase in the tensile force acting on the upper base, whereas the tensile force acting on the lower base is even more sharply reduced and may actually become negative at the center and at the ends, i.e., these parts are placed under compression, which is absolutely inadmissible. Rows 57 and 58 show this clearly.

We shall now consider the effect on the bases of the weight of the motor and the insignificant lift force moment of the ends of the envelope (under which there is no gondola). The large supplies of fuel required for refilling the middle of the envelope (above the gondola) with gas must be distributed over the entire gondola in accordance with the lift forces of the compartments. We shall therefore deal with the weight of the motor and the end lift force moments.

For a speed of 78 km/h the engine power will be 198 metric units or 264 hp. Each motor contributes 132 units and a weight of 132 kg. If the speed of the dirigible is doubled, i.e., increased to 156 km/h, the weight of each motor will increase to 1,050 kg.

Note that doubling the speed cuts the maximum range to one fourth, but it is advantageous in relation to the heating of the hydrogen, since it broadens its range and rapidity.

The lift force of the end compartment of the gondola is 629 kg (row 34). With two or three mechanics accounting for 200 kg, 429 kg will remain. The additional load will be $1054 - 429 = 625$ kg. How will this load behave and to what extent will it balance the lift force moment developed by the end of the envelope?

Rows 59 and 60. We calculate the moments (row 60) for a load of 625 kg at each cross section, using the distance between the load and that cross section (row 59).

Row 61. The additional positive forces exerted on the bases are determined by dividing by the diameters of the cross section (row 49).

Rows 62 and 63. The lift force moment of the end of the envelope projecting beyond the gondola can be found, at different cross sections, by multiplying the moment about the center cross section (cf. row 45, here we find 20,618 kg-meter) by the ratio $\frac{x_1 - x}{x_1}$. This

ratio is given in row 62, and the (approximate) moment in row 63.

Row 64. This row contains the corresponding negative contribution to the force on the bases.

Row 65. Comparing this with the positive contribution due to the weight of the motor (row 60), we see that they at first almost balance each other out, but then the negative component due to the lift force at the ends begins to predominate. This is clearly evident from row 65.

Rows 66 and 67. Taking as a starting point the tensile force due to the gas pressure (row 51) and modifying it, we find from row 65 the true forces acting on the upper (row 66) and lower (row 67) bases.

IV. Design Features of a Metal Dirigible

In this chapter I shall not only describe the drawings but also present additional information on the design of a dirigible built to carry 40 persons.

43. Only half the dirigible is shown in the drawings, since the two halves are almost identical. The drawing of the propellers, control surfaces, and various other parts is schematic: only the approximate dimensions and areas are shown. Only the direction of the corrugations is represented, since they are too small to be distinguishable.

44. Fig. 4 shows a side elevation of the dirigible and plan views from above and below. The direction of the corrugations is indicated.

45. Fig. 5 gives some idea of the suspension system. The pulley blocks are small enough to be represented as points. The tensioning drum and the gastight housing enclosing it are barely distinguishable in the diagram.

46. Fig. 6 shows cross sections through the same envelope at various distances from the center (0.2; 0.4; 0.6). The relative distance of these sections from the center section is indicated on the drawings. The tensioning system is shown in the first three drawings, but not in the remainder.

TABLE 3

	0	0.1	0.2	0.3	0.4
1 Relative distance to center cross section (x/x_1)	0	0.1	0.2	0.3	0.4
2 Auxiliary variable $1 - (x/x_1)^2$	1	0.99	0.96	0.91	0.84
3 Auxiliary variable $\sqrt{1 - (x/x_1)^2}$	1	0.995	0.980	0.954	0.9165
4 Auxiliary variable $\sqrt[4]{1 - (x/x_1)^2}$	1	0.9975	0.990	0.977	0.957
5 Relative ordinates of flat envelope	1	0.9925	0.9698	0.9317	0.8774
6 Tangents of angles of flat envelope	0	0.0379	0.0763	0.1138	0.1584
7 True distances to center cross section	0	6	12	18	24

[Table 3 cont'd. on next page]

TABLE 3

	0.5	0.6	0.7	0.8	0.9	1.0
1 Relative distance to center cross section (x/x_1)						
2 Auxiliary variable $1 - (x/x_1)^2$	0.75	0.64	0.51	0.36	0.19	0
3 Auxiliary variable $\sqrt{1 - (x/x_1)^2}$	0.866	0.800	0.714	0.600	0.436	0
4 Auxiliary variable $\sqrt[4]{1 - (x/x_1)^2}$	0.931	0.894	0.845	0.775	0.660	0
5 Relative ordinates of flat envelope	0.8059	0.7155	0.6035	0.4648	0.2728	0.082
6 Tangents of angles of flat envelope	0.2032	0.2539	0.3136	0.3902	0.5151	0.5151
7 True distances to center cross section	30	36	42	48	54	60

[Table 3 cont'd. on next page]

[Table 3 cont'd.]

	Relative distance to center cross section (x/x_1)	0	0.1	0.2	0.3	0.4
1	Relative distance to center cross section (x/x_1)	0	0.1	0.2	0.3	0.4
8	Ordinates of flat envelope	15	14.887	14.547	13.975	13.161
9	Double ordinates of flat envelope	30	29.774	29.094	27.950	26.322
10	Same, plus width of base	32	31.774	31.094	29.950	28.322
11	Radii of cross sections of fully inflated envelope	10.191	10.120	9.836	9.504	9.019
12	Diameters of cross sections of fully inflated envelope	20.38	20.24	19.67	19.01	18.04
13	Cross-sectional areas of in- flated envelope	326	320	304	283	254
14	Width of compartments of fully inflated envelope	3	6	6	6	6
15	Volumes of these compartments or cones of fully (100%) in- flated envelope	973	1920	1824	1698	1524
16	Lift force for each compart- ment (1.2 kg per cubic meter)	1173	2304	2188	2037	1828

[Table 3 cont'd. on next page]

[Table 3 cont'd.]

	0.5	0.6	0.7	0.8	0.9	1.0
1	Relative distance to center cross section (x/x_1)					
8	12.088	10.732	9.052	6.972	4.317	1.23
9	24.176	21.464	18.104	13.944	8.634	2.46
10	26.176	23.464	20.104	15.944	10.634	4.46
11	8.336	7.473	6.403	5.078	3.387	1.23
12	16.67	14.95	12.81	10.16	6.77	2.46
13	219	174	128	80	35	4.92
14	6	6	6	6	6	3
15	1314	1044	768	480	210	35
16	1576	1252	921	576	252	42

[Table 3 cont'd. on next page]

[Table 3 cont'd.]

	0	0.1	0.2	0.3	0.4	
1	Relative distance to center cross section (x/x_1)					
17	Compartment volume for 75% inflation	733	1440	1368	1273	1143
18	Lift force for 75% inflation	880	1728	1641	1527	1372
19	Double area of lateral trapezoids of flat envelope	180	356	347	335	316
20	Weight of each pair of lateral trapezoids	234	463	451	436	411
21	Weight of two base segments of each cone	50	100	100	100	100
22	Total weight of conical compartment	284	563	551	536	511
23	Lift force for each compartment after subtracting weight for 100% inflation	890	1741	1637	1501	1317
24	Same, for 75% inflation	595	1165	1090	991	860
25	Difference in lift force for 100% and 75% inflation	293	575	547	509	455

[Table 3 cont'd. on next page]

[Table 3 cont'd.]

	0.5	0.6	0.7	0.8	0.9	1.0
1	Relative distance to center cross section (x/x_1)					
17	Compartment volume for 75% inflation	985	783	576	360	157
18	Lift force for 75% inflation	1182	940	690	432	189
19	Double area of lateral trapezoids of flat envelope	290	270	217	167	104
20	Weight of each pair of lateral trapezoids	377	351	282	217	135
21	Weight of two base segments of each cone	100	100	100	100	100
22	Total weight of conical compartment	477	451	382	317	235
23	Lift force for each compartment after subtracting weight for 100% inflation	1099	801	539	259	17
24	Same, for 75% inflation	705	488	308	115	-46
25	Difference in lift force for 100% and 75% inflation	392	313	230	144	63

[Table 3 cont'd. on next page]

[Table 3 cont'd.]

	0.5	0.6	0.7	0.8	0.9	1.0
1	Relative distance to center cross section (x/x_1)					
26	Weight of cable tensioning system					
27	Weight of heating system					
28	Weight of gondola hangers					
29	Weight of gondola roof					
30	Weight of gondola floor					
31	Weight of interior contents of gondola					
32	Total weight of gondola					
33	Weight of gondola compartments under envelope cones					
34	Useful load capacity of each compartment for 100% inflation					
35	Same, for 75% inflation					
36	Useful load capacity per meter of gondola for 100% inflation					
	444	222		no gondola		
	655	579	539	259	17	-49
	261	266	308	115	-46	-60
	109	193	90	43	3	-16

[Table 3 cont'd. on next page]

[Table 3 cont'd.]

		0	0.1	0.2	0.3	0.4
1	Relative distance to center cross section (x/x_1)					
37	Same, for 75% inflation	125	120	108	91	69
38	Longitudinal gas pressure on different cross sections	7824	7680	7296	6792	6096
39	Relative ordinates of inflated envelope (from row 11)	1.000	0.993	0.970	0.932	0.885
40	Ratio of gas pressures on upper and lower bases	1.286	1.284	1.272	1.264	1.248
41	Longitudinal gas pressure on upper base	4407	4310	4.082	3788	3387
42	Longitudinal gas pressure on lower base	3417	3370	3214	3004	2709
43	Distance of center of each compartment from center cross section	1.5	6	12	18	24
44	Lift force moments of compartments about center cross section (rows 25 and 43)	440	3450	6564	9162	10,920

[Table 3 cont'd. on next page]

[Table 3 cont'd.]

		0.5	0.6	0.7	0.8	0.9	1.0
1	Relative distance to center cross section (x/x_1)						
37	Same, for 75% inflation	44	89	51	19	-8	-20
38	Longitudinal gas pressure on different cross sections	5256	4176	3072	1920	840	118
39	Relative ordinates of inflated envelope (from row 11)	0.817	0.732	0.628	0.498	0.332	0.120
40	Ratio of gas pressures on upper and lower bases	1.228	1.201	1.171	1.133	1.086	1.030
41	Longitudinal gas pressure on upper base	2797	2278	1656	1020	437	60
42	Longitudinal gas pressure on lower base	2459	1898	1416	900	403	58
43	Distance of center of each compartment from center cross section	30	36	42	48	54	58.5
44	Lift force moments of compartments about center cross section (rows 25 and 43)	11,760	11,268	9660	6912	3402	644

[Table 3 cont'd. on next page]

[Table 3 cont'd.]

1	Relative distance to center cross section (x/x_1)	0	0.1	0.2	0.3	0.4
45	Sum of moments of ends about center cross section (from row 44)	74,182	73,742	70,292	63,728	54,566
46	Sum of lift forces of entire end of envelope (from row 25)	3532	3239	2664	2117	1608
47	Product of rows 46 and 43	5298	19,434	31,968	28,106	38,592
48	Moment of part of envelope about its own cross section (from rows 45 and 47)	68,884	54,308	3824	25,622	15,974
49	Diameter of cross section	20.4	20.2	19.7	19.0	18.0
50	Resulting tensile or compressive force on bases (from rows 48 and 12, or 49)	3636	2688	1955	1348	870.7
51	Tensile force on upper base due to combined action of vertical forces and gas pressure	771	1622	2127	2440	2516
52	Tensile force on lower base due to combined action of vertical forces and gas pressure	7053	6058	5169	4352	3580

[Table 3 cont'd. on next page]

[Table 3 cont'd.]

		0.5	0.6	0.7	0.8	0.9	1.0
1	Relative distance to center cross section (x/x_1)						
45	Sum of moments of ends about center cross section (from row 44)	43,646	31,886	20,618	10,958	4046	644
46	Sum of lift forces of entire end of envelope (from row 25)	1153	761	448	218	74	11
47	Product of rows 46 and 43	34,590	27,396	18,816	10,464	3996	643.5
48	Moment of part of envelope about its own cross section (from rows 45 and 47)	9056	4490	1802	494	50	0
49	Diameter of cross section	16.7	15.0	12.8	10.2	6.8	2.5
50	Resulting tensile or compressive force on bases (from rows 48 and 12, or 49)	542.3	299.3	140.8	48.4	7.4	0
51	Tensile force on upper base due to combined action of vertical forces and gas pressure	2248	1979	1515	972	430	60
52	Tensile force on lower base due to combined action of vertical forces and gas pressure	3008	2197	1557	948	410	58

[Table 3 cont'd. on next page]

[Table 3 cont'd.]

1	Relative distance to center cross section (x/x_1)	0	0.1	0.2	0.3	0.4
53	Distance of load (1716 kg) from cross section. Load placed at extreme ends of dirigible.	60	54	48	42	36
54	Moments of load (1716 kg) placed at extreme ends of dirigible about each cross section	10,290	92,610	82,320	72,030	61,740
55	Force acting on bases due to loads at ends of dirigible (from rows 49 and 54)	5044	4585	4200	3791	3430
56	Combined effect of end loads and lift forces on bases	1408	1897	2245	2443	2559
57	Forces acting on upper base due to action of gas, load, and lift force	5815	6207	6327	6231	5946
58	Same, for lower base	2009	1473	969	561	150
59	Distance of motor from cross section	36	30	24	18	12
60	Moments of weight of motor about cross section	22,500	18,750	15,000	11,250	7500

[Table 3 cont'd. on next page]

[Table 3 cont'd.]

	0.5	0.6	0.7	0.8	0.9	1.0
1	Relative distance to center cross section (x/x_1)					
53	30	24	18	12	6	0
54	51,450	41,160	30,870	20,580	10,290	0
55	3081	2744	2415	2018	1513	0
56	2539	2445	2274	1970	1506	0
57	5336	4723	3930	2990	1943	60
58	-80	-547	-858	-1070	-1103	-58
59	6	0	-	-	-	-
60	3750	0	-	-	-	-

[Table 3 cont'd. on next page]

[Table 3 cont'd.]

	Relative distance to center cross section (x/x_1)	0	0.1	0.2	0.3	0.4
61	Additional forces acting on bases (rows 49 and 60) due to weight of motor	1103	929	761	592	417
62	$\frac{x_1 - x}{x_1} = 1 - \frac{x}{x_1}$	1	0.9	0.8	0.7	0.6
63	Moments of lift force of end of envelope projecting beyond gondola	20,600	18,540	16,560	14,490	12,420
64	Negative contribution to force acting on bases due to lift force at end of envelope (rows 49 and 63)	1010	918	841	771	90
65	Combined action of lift force at end and weight of motor (rows 61 and 63)	93	11	-80	-179	-273
66	Force acting on upper base (rows 41 and 65), final value with all corrections made	4410	4321	4002	3609	3114
67	Force acting on lower base (rows 42 and 65), final value with all corrections made	3324	3359	3294	3183	3082

[Table 3 cont'd. on next page]

[Table 3 cont'd.]

	0.5	0.6	0.7	0.8	0.9	1.0
1	Relative distance to center cross section (x/x_1)					
61	225	0	-	-	-	-
62	0.5	0.4	-	-	-	-
63	10,350	8280	-	-	-	-
64	620	-	-	-	-	-
65	-395	-	-	-	-	-
66	2402	1979	1515	972	430	-
67	2854	2197	1557	948	410	-

46. Fig. 7 shows the shape of the center cross section through the envelope at various stages of inflation. This shape will depend upon: the aspect ratio of the envelope, the tensile forces acting on the corrugations (in the side walls), the relative weight of the envelope, the gas pressure, and other factors. The corrugated envelope will withstand any conditions without forming irregular folds.

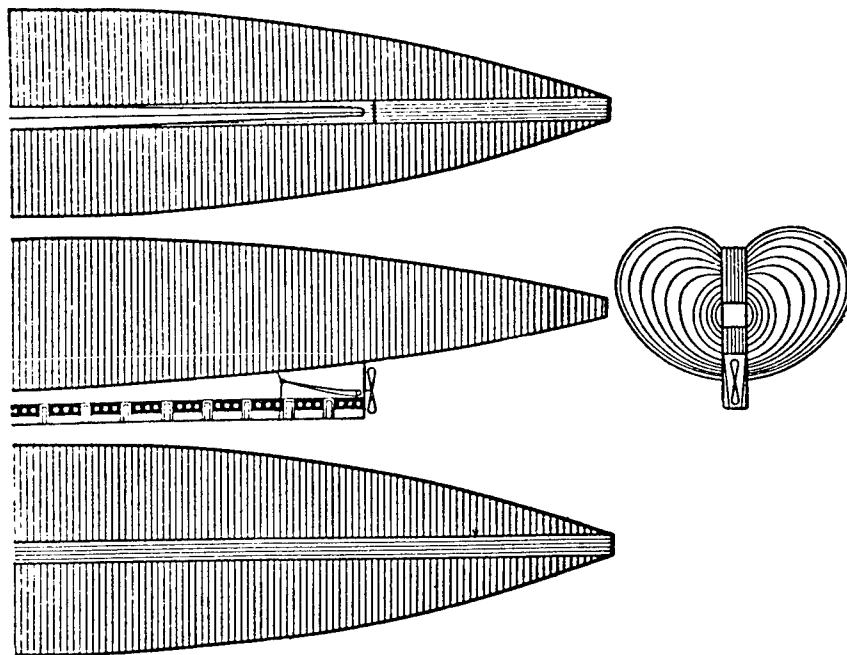

Fig. 4

47. Fig. 8 shows a full-scale cross section through the side walls or corrugations*. Starting from the top, we have:

*In the author's manuscript; the scale is actually about 1:4, however.

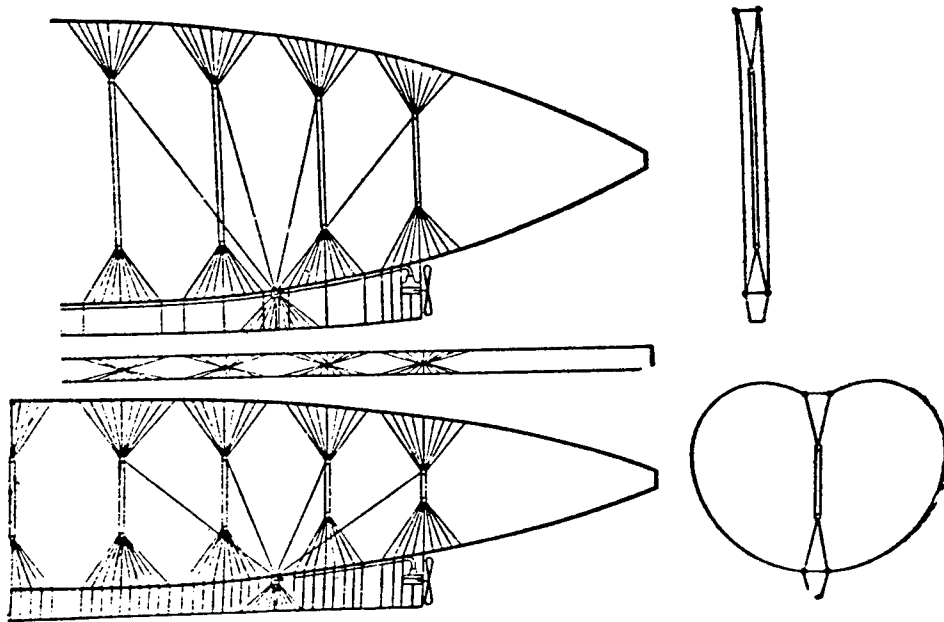

Fig. 5

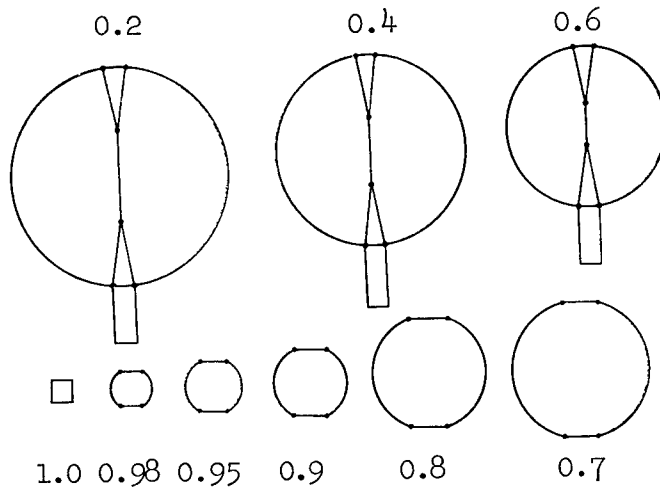

Fig. 6

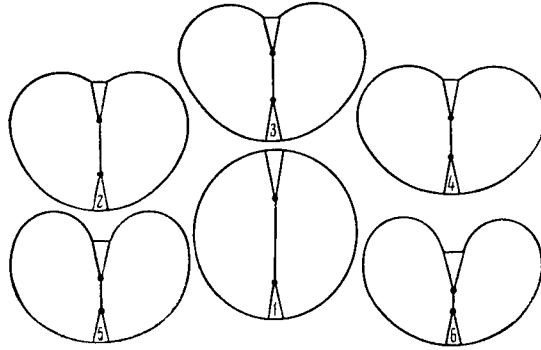

Fig. 7

1) the theoretical size of the corrugations (for a steel envelope 0.2 mm thick);

2) the smallest possible corrugations (lacks elasticity under tension; this is permissible if there is no need to let out all the gas at frequent intervals, so that the envelope collapses);

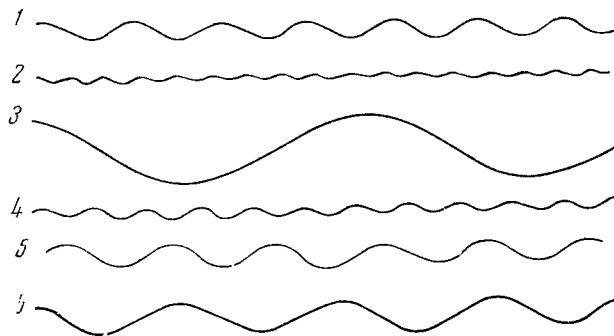

Fig. 8

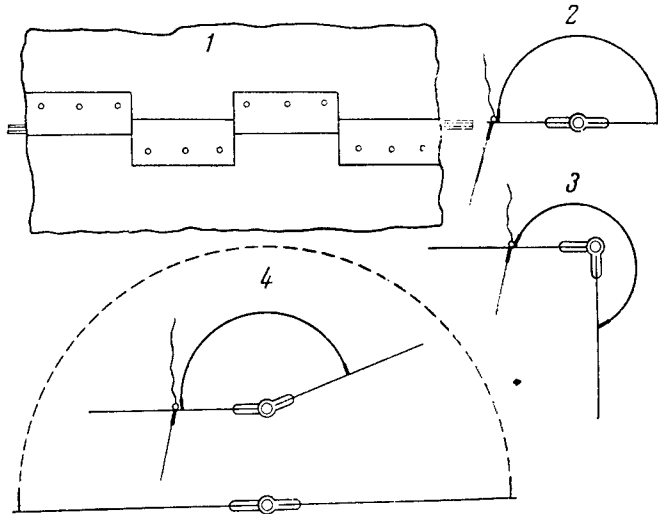

Fig. 9

3) the largest possible corrugations (lacks rigidity resulting in the formation of irregular folds and cracks; if the corrugations are too large, shallow second-order corrugations superimposed on the large ones must be introduced);

4) also my recommended corrugations;

5) mean dimensions of the corrugations, close to the theoretical.

48. The same drawing shows the corrugations of the base to full scale*. They run longitudinally and are three times as large as the corrugations in the side panels. But they may also be much shallower and even have a different slope. The purpose of these corrugations is to lend a certain rigidity to the base. They alternate with flat surfaces. The corrugations of the side panels and bases run [approximately] at right angles.

Flat surfaces are left wherever any inelastic element is in contact with the bases.

49. Fig. 9 shows the hinged connection between the side panel and the bases to full scale*. The first drawing shows a plan view of the hinges and rod from above; the second, third, and fourth drawings show the same hinges in cross section, and the channels shielding the hinged joints are also indicated. The large broken semicircle gives the largest dimensions of the channel. The thickness of the material of which the connections are made is the same as that of the bases (0.45 mm). The thickness of the channels is the same as that of the side panels (0.15 mm). The number of hinge leafs and the thickness of the rod are such that the transverse resistance of the rod is equal to the transverse resistance of the corresponding portion of the side panels. The transverse strength of the hinge leafs, edge plates, and bases is not merely adequate, but three times that of the side panels.

50. The strength P_r of the rod per unit length of the side walls will be:

$$P_r = \pi r^2 \frac{K}{n} \cdot \frac{1}{l},$$

where r is the radius of the rod cross section; K is the ultimate strength; n is the safety factor; and l is the length of the hinge (its width is undetermined; the shorter the better).

On the other hand, the strength of unit length of the side panels P_s will be

$$P_s = \delta, \frac{K}{n},$$

*In the author's manuscript; the scale is actually about 1:4, however.

where δ is the thickness of the side panels.

Equating these quantities, we find

$$t = \frac{\pi r^2}{\delta} \text{ and } r = \sqrt{\frac{t\delta}{\pi}} .$$

Assuming $\delta = 0.15$ mm and assigning the hinge length t successive values of 10, 20, 30 mm, etc., we can compile the following table.

TABLE 4

Length of hinge, mm	10	20	30	40	50	60	70	80	90	100
Rod thickness, mm	1.4	1.96	2.40	2.76	3.10	3.42	3.68	3.90	4.16	4.38

This means that the longer the hinges or, in other words, the fewer the hinges required over the total length of the envelope, the thicker the rod. Some economy (negligible, to be sure) will be achieved by using very short hinges.

In Fig. 9, the hinges are 5 cm long, corresponding to a rod thickness of 3.1 mm (cf. Table 4).

One group is fastened to the base, while the other "intermediate" group is fastened to a special edge plate of the same thickness as the base, which in turn is welded to the side panels.

Fig. 9 also shows the connections for the tensioning system and for docking the dirigible to permit deflation and overhaul.

In the case of large dirigibles, the connections can be slipped over the rods between hinges. I have built many models based on this principle.

The channels to prevent gas leakage may also be located inside the envelope. An outside cover to keep out rain and moisture will then be required. This cover should also be leakproof, i.e., we can use double channels, inside and out. They could be made of some flexible fabric.

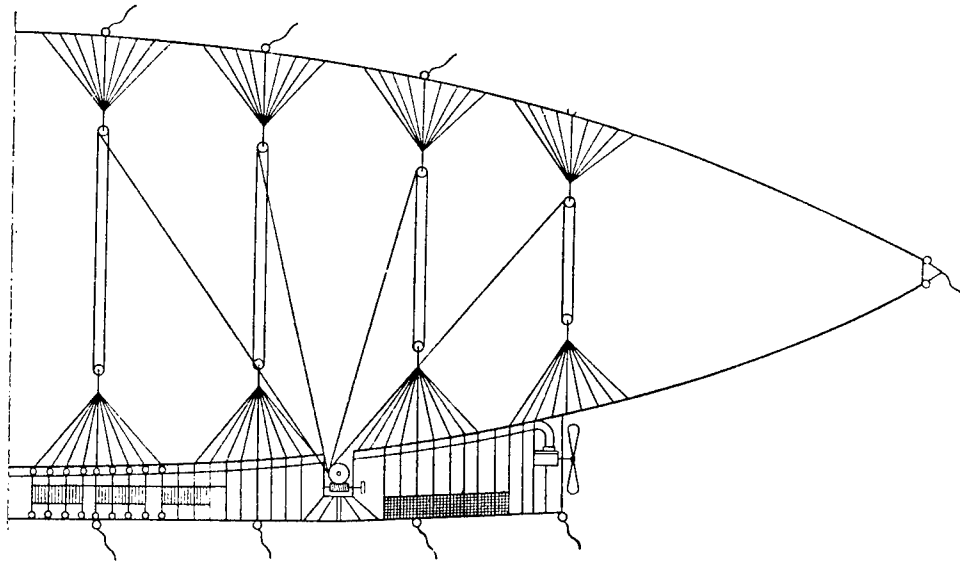

Fig. 10

The openings of the hinge leafs must be made larger than the rod, to provide at least a measure of rolling friction.

51. Fig. 10 depicts a flat dirigible with hooks and rings for the suspension of the envelope itself and for the attachment of the cables of the tensioning system and the gondola. The details of

the tensioning system have been deliberately exaggerated, otherwise they would not be visible at all in a drawing to this scale. Blocks and pulleys, cables, the tensioning drum in its gastight housing, motor, propeller, and heating tube are also shown to a larger scale.

Not all the cable connections are indicated, only a few typical ones and their positions. On top they may be paired to conform with the base.

They are used to suspend the envelope during deflation and also when the dirigible is being inflated after fabrication on a horizontal platform in the flat configuration. The lower base must also have connections, and all must be integral with the interior tension members. The latter may be welded directly to the base (without rings), since they do not experience bending or changes in inclination at the point of attachment.

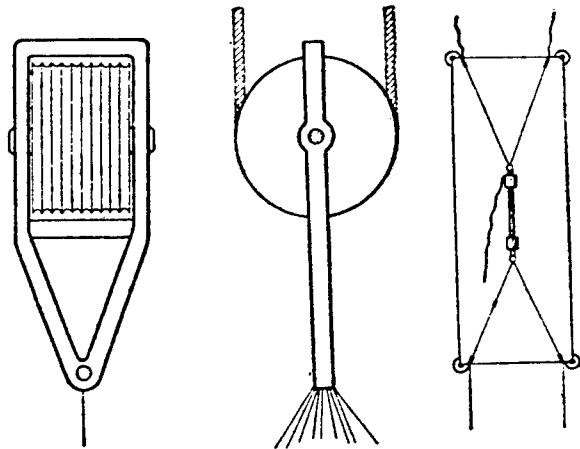

Fig. 11

The vertical hangers supporting the gondola should have loose connections at top and bottom, so that the gondola is capable of small displacements. But these may be dispensed without any great risk (or cables may be used instead). The lower connections are

attached to the bottom framing of the gondola (Fig. 10). Cables are lowered from them when the dirigible lands or is moored to its mooring mast. Mooring can also be accomplished with the aid of cables attached to the bases, since the latter are very strong in tension.

52. The blocks of the tensioning system (Fig. 11) must be made of the lightest and strongest material, e.g., of choice timber in a metal casing. The number of pulley wheels in each yoke will be not less than 5 and not more than 10. In the first case, the average tension on a single cable will not exceed 350 kg. In fact, the average tension on all the cables will not exceed the total lift force of the dirigible, i.e., 28 tons (cf. table above). In our case the number of pulley systems will be 8 with 10 wheels in each. Thus there will be 80 cables. The tension on each will be 350 kg. With 10 wheels on one axis (in a pulley system of 20 wheels), the tension will be 175 kg.

We shall assume this number of wheels in our pulley system. The steel wire supporting this load will need a cross-sectional area

$$f = \frac{P}{K/n}.$$

Assuming $K/n = 10 \text{ kg/mm}^2$ for steel and a load of 175 kg, we find $f = 17.5 \text{ mm}^2$. The wire will be 4.72 mm thick, and one meter of the wire will weigh 0.14 kg. A very heavy and large pulley wheel would be required to bend this wire elastically. Clearly, the wire must consist of a large number of fine strands, i.e., it must be a cable. Formula (272) gave us

$$h = y \frac{\sigma}{E},$$

where σ is the elastic strength of the material; E is the modulus of elasticity; h is the thickness of the wire; y is the radius of the

wheel (or bending radius of the wire). For the best-quality tempered steel $\frac{\sigma}{E} = 0.004$ (cf. (307)). This enables us to compile the following table.

TABLE 5

Pulley diameter, cm		4	6	8	10	12	14	16	18	20	30	40	50
Wire thickness, mm	if $\frac{\sigma}{E} = 0.004$	0.08	0.12	0.16	0.20	0.24	0.28	0.32	0.36	0.4	0.6	0.8	1.0
	if $\frac{\sigma}{E} = 0.002$	0.04	0.06	0.08	0.10	0.12	0.14	0.16	0.18	0.2	0.3	0.4	0.5

If the diameter of the pulley wheel is 10 cm, the thickness of an elementary strand of the cable will be 0.1 to 0.2 mm.

As is known, the relative strength of such wires is the greater the finer the wire. This is the second advantage of using cables (the first advantage being flexibility and the small size of the pulleys). Thus, the cable thickness will not be more than 5 to 8 mm. Clearly, then, the thickness of the wheel will not be more than 1 cm, and the thickness of 10 wheels on a single axis will not be more than 10 cm. The projection of each block will be square.

The pulley system must be so constructed that the cable cannot slip free.

A typical compound block is shown in Fig. 11. In this case the diameter of the wheels is 16 cm.

In view of the dimensions and the lightness of the material used, the total weight of each block will not be more than 2 to 3 kg.

Then the set of eight pulley systems (16 compound blocks) will not weigh more than 32 or 48 kg.

We found the weight of the tensioning system to be 440 kg (cf. table, p. 26). We shall assign the same weight to the pulley systems and their various accessories. It is clear that the diameter of the pulleys could even be twice as great without creating difficulties.

The combined length of all the cables is found from the drawings to be approximately 1010 meters. The weight of one meter of cable is about 0.14 kg. The total weight of all the cables will therefore be 141 kg.

I repeat: the figure 880 kg includes the entire tensioning system. The pulley blocks account for not more than 50 kg, the cables for 141 kg. The fixed ties account for not more than 440 kg. This leaves not less than 249 kg for the tensioning drum, its housing and motor.

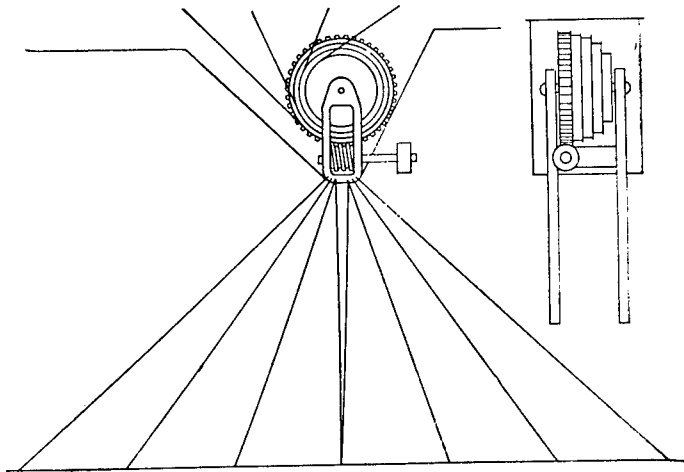

Fig. 12

But we have assigned much too large a portion to the fixed ties (440 kg), assuming that they average 20 meters in length. Actually, the length of the pulley system should be deducted from

this figure. We see clearly from the drawings that 300 kg would be quite enough, so that there will still be 140 kg left, to make a total of 389 kg.

In Fig. 5, top right, we see a schematical cross section through an uninflated envelope. The arrangement of the hinges, tensioning system, protective channels, pulleys, and connections (for the tensioning system and for suspending the gondola and the dirigible itself) is clearly shown.

There is no particular need for a large safety factor for the members of the tensioning system. Failure of these members would cause inconvenience, but would not imperil the safety of those on board. The gondola hangers are the members that must be made particularly strong.

53. It is clear from Fig. 5 that the envelope is tensioned at two points in the gondola 21 meters from the center, i.e., 42 meters apart, 15 meters from the ends of the gondola (the motors), and 39 meters from the ends of the envelope.

Fig. 12 indicates the method used in tensioning the envelope. The tension in one cable may amount to 175 kg, that in all four cables may reach 700 kg. Clearly, the tensioning equipment must be built very sturdily.

The tensioning drum toothed wheel and worm drive are mounted in a common metal frame. The frame is connected by means of braces to the floor of the gondola and its heavy longitudinal framing. A lightweight housing covers the machine, thereby preventing leakage of gas. The shaft of the worm drive operated by a special motor at one end is the only part projecting outside this gastight housing.

The mechanism and braces are located on one side or in the middle of the gondola. At that point, the gondola floor will have to be reinforced. It would also prove useful to prestress the gondola floor to balance the tension on the cables.

It is clear from Fig. 12 that the braces take up about 6 meters of the gondola length. The corresponding lift force (according to the table) is 100 to 180 kg per meter or 600 to 1080 kg over 6 meters. Therefore no increased load is required. But with five wheels in each block, an increased load will be necessary, since the tension will be doubled (7002 kg). Passengers' baggage or other cargo could be stored here.

The amount of tension on different parts of the envelope will lessen as the cross section narrows. The tensioning drum should therefore be stepped, i.e., it should consist of a sequence of discs of different diameters. The ratios will be 1.00; 0.95; 0.86; 0.72 (according to the relative diameter of the cross sections of the

envelope where the tension is applied). The cables may remain cables over their entire length, provided their ends are fastened to the tensioning drum and wound around it to correspond with the tension applied to the envelope at that point. It is not advisable to make the drum a small one, since more space is then required to wind the cables.

It would be desirable to tighten the envelope by 1 to 2 meters. Given a set of ten wheels in each pulley block, 20 to 40 meters of cable would have to pass through the pulleys. If the average drum diameter is 1 meter, 3 meters of cable would be wound around the drum in one turn. For 20 to 40 meters this means 7 to 14 turns. The thickness of the cable will not exceed 1 cm. Consequently, if the winding is uniform, the width and height of the grooves in the pulley wheels need not exceed 3 to 4 cm.

As we see, the diameter of the drum could be halved. We would then get 13 to 26 turns. The cross section of the groove would not be greater than 4-5 cm, which is not much for a 50-cm wheel. We shall use this diameter.

This means that each step of the stepped drum measures 5 cm, or 20 cm in all for a set of four discs. Allowing for the rims or walls of the grooves and the toothed wheel, the entire drum will not be longer than 30 cm (for a diameter of 50 cm). In Fig. 6 the drum diameter is assumed to be 1 meter.

Each tooth meshing with the worm drive, assuming a square section, must be about 1 cm in cross section, since it will have to withstand a load of as much as 1000 kg. Clearly then, the entire drum together with its frame and braces need not weigh so very much, if it is made of good material: the weight will be not more than about 200 to 300 kg.

The higher the dirigible rises, the more the cables are paid out. The purpose of the worm drive is to allow the cables to pay out independently with the envelope tension, i.e., without the motor or a special brake mechanism playing a part. The worm itself will act as a brake.

There are two such tensioning drums in the dirigible. In general, they apply the same tension to the envelope.

The two drums rotate in opposite directions to enable the dirigible to recover its horizontality when tilted.

But one drum can be left inactive, while the other is in operation, thereby placing only half the envelope under tension, or relaxing half the envelope, depending on the extent to which the longitudinal axis of the ship is tilted.

If the envelope is well balanced, the weather is calm, and the dirigible is flying at a certain altitude, the horizontal control surface alone will serve to stabilize the craft.

Then there will be no need to apply tension in order to create normal hydrogen pressure in the envelope: a safe pressure will be most simply obtained by means of the temperature regulator. If the pressure is high, the temperature is reduced, the dirigible loses altitude, and the pressure returns to normal. The reverse process is adopted if the pressure is too low.

As a result, the average work done per hour in applying tension is modest, but occasionally, when it is necessary to tighten the envelope, the work rate will be higher. To lose 1 km of altitude, the envelope will have to be drawn in by 2 meters, i.e., the gondola will have to be raised by the same amount. However, the gondola together with all its contents will not weigh more than 20 tons. This means that the work done will amount to 40 meter-tons. If the dirigible descends 1 km in 100 sec, the work done in tightening the envelope will be 400 kg-meters per sec, or 4 metric work units. The rate of descent will be 10 meters a second. At a rate of 5 meters a second, the work would amount to 2 units.

In ascending the work done would be equal and opposite, were it not for the friction of the worm drive which absorbs it.

Thus, 2 to 4 metric work units must be applied to each drum by the motor. It would be more economical to operate the tensioning system by using the main engines. These are 15 meters away. Pneumatic or electric power transmission would be most economical from the standpoint of weight. Then the tensioning drum could be supplied with 100 hp, or even more, directly, and could thus operate at an unusually fast rate.

But it would be advisable for the tensioning drum to be operated independently of the main engines. Gasoline or gas motors, which start up rapidly, would be needed. But this, of course, will not mean any savings in weight.

The horizontal trim of the dirigible cannot be maintained by two methods at once (the horizontal control surface and the tensioning system, for example). An attempt must first be made to restore horizontal trim by means of the tensioning system alone, and if possible, to do without the horizontal control surface.

A fortiori, it will not be possible to make use of three or more stabilization methods simultaneously, for example, by adding to the first two methods uneven heating of the hydrogen inside the envelope by means of the temperature regulator.

But the last method may be used alone to stabilize the longitudinal axis of the dirigible.

54. Fig. 13 depicts a plan view of the floor of the two halves of the gondola almost from the middle to the ends, i.e., over a length of 34 meters (top two diagrams).

The bottom diagrams are cross sections through the gondola and its floor.

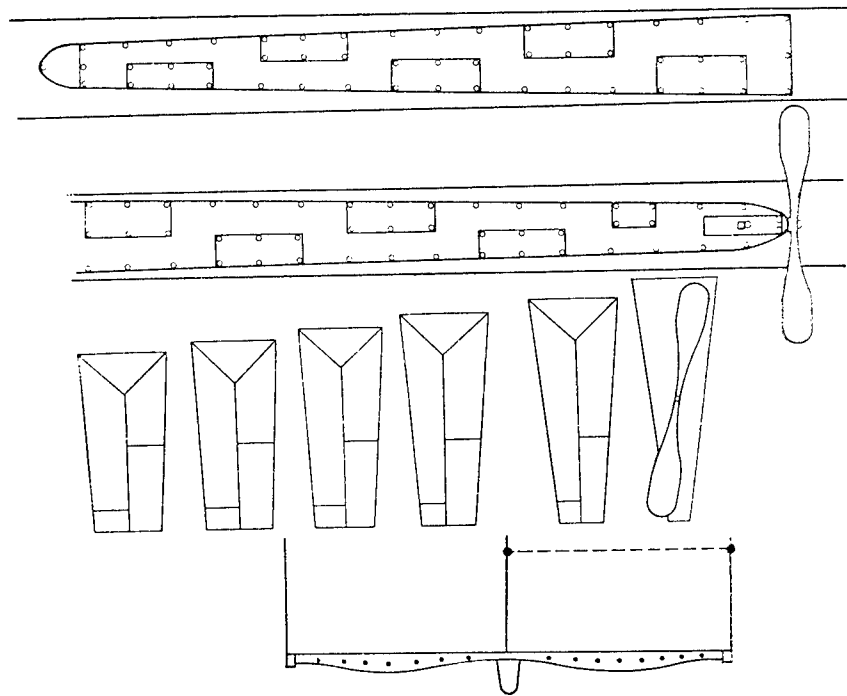

Fig. 13

It is clear from the layout that each square meter of the floor will have four hangers at the corners, by which it will be suspended (only at the ends of the gondola are the hangers spaced more closely). These constitute an extension of the ties forming the tensioning system (cf. the third drawing) and are supported at the top of the envelope where the gas pressures may be up to 5 tons. The hangers are marked with circles in the drawing. There will be 219 of them distributed over the gondola. They will present no obstacle to the movements of the passengers and crew, since there

will be one meter clearance in between except at the ends of the gondola.

Not only the floor, but also the bunks, tables, cabinets, seats, and access ladders or stairways will be supported by these members. This will reduce their weight. They may even be made of light fabric or mesh. The double bunks are spaced one meter apart; the lower one is half a meter above the floor, the upper one 2 meters. Only the lower berths are shown in the first two drawings. The upper berths are not indicated, but they occupy the empty spaces in the drawing at a height of 2 meters. Thus they will not hinder the free passage of those on board either. Passengers and crew will have to twist and turn a little, but their movements will not be seriously impeded. Only at the ends of the gondola is the free space reduced to half a meter.

The bunks are designed for sleeping, but the lower ones will serve as seats during the day. There will be a total of 40 bunks, corresponding to the number of people on board. The 20 lower berths will provide enough seating space for the passengers and crew. A seat needs to be 50 cm square, so that a single bunk (2 meters long and one meter wide) will accommodate 6 people, and still leave some room.

The best procedure would be to make the lower bunks so that in the daytime they could be converted into two suspended armchairs. People could then sit sideways and stretch their legs along the length of the gondola; then they would not get in the way. This is clear from the third drawing, where the bunks are shown.

The fourth drawing shows a cross section through the floor of the gondola to a scale of 1:10.

Initially, my plan is to make the floor of separate pieces of the strongest lumber available. The boards would be arranged with the grain running across the gondola. They would have to be glued and screwed together and faced with a thin layer of metal or coated with a waterproof metal paint to prevent leaks and reduce the fire hazard. The variable thickness (clearly indicated in the drawing) is intended to save weight.

Longitudinal members would run along the edges and through the center of the floor, to provide greater strength. The center beam would be very heavy (and also provisionally of wood). It would also serve as a support for the cables (guide ropes) used in handling the dirigible and in mooring the craft to the tower or mast.

In order not to make the floor too heavy and at the same time as a safety precaution, the underside would have to be reinforced with a layer of tough steel wire mesh. This mesh would form a sort of safety net if the floor were damaged.

Naturally, in due course the floor would be made of metal, but

for the time being a compromise is in order.

Cables attached to one or both bases (Fig. 1 and Fig. 11) could also be used for mooring.

But a more convenient method would be to couple the gondola to the mast directly, since this would mean that the mast need not be so high; the task of maintaining the horizontal trim can be assigned to the tensioning system. The embarkation of passengers will also be easier. The stopping of the motors when the ship is moored to the mast must be accompanied by the simultaneous disembarkation of the passengers, and, in general, by an equalization of the lift force.

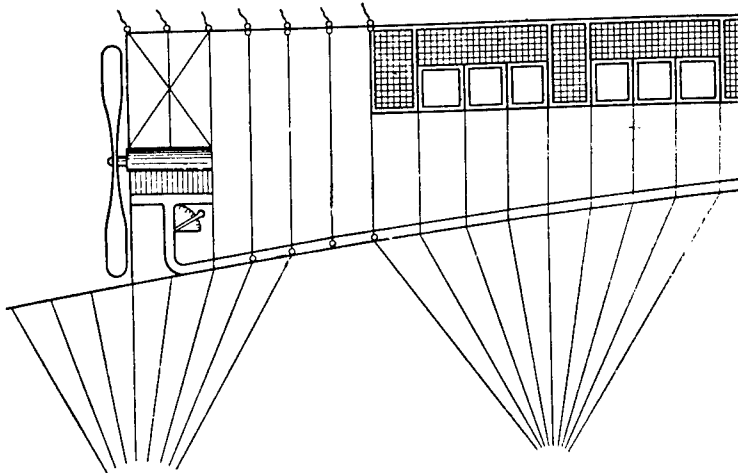

Fig. 14

55. Fig. 14 shows the positions of the motor, temperature regulator, and heating tube. We also see the windows and doors and gondola connections (to an exaggerated scale).

56. Details of the design of the temperature regulator are given in Fig. 15. The motor is schematically represented. The upper drawing gives a longitudinal section, and the lower drawing a plan view.

The outlets for the cylinder gases must be surrounded by a special gasproof housing, through which the gases are brought to the temperature regulator, consisting of a square duct. A rectangular baffle is free to rotate in the duct; this either seals off the duct, preventing the further upward passage of hot gases (when the baffle plate is raised), or flaps against the large opening in the duct, permitting the gases to flow freely into the dirigible heating tube (vertical position of the plate). In the first case, all the hot gases will be ejected, and the hydrogen in the dirigible envelope will receive almost no heat. In the second case, on the other hand, all the gas will be deflected into the heating tube, and almost all its heat will be transmitted to the dirigible. In the intermediate case, part of the combustion products will be ejected, while the remainder will be allowed to enter the heating tube. It is clear that the degree to which the hydrogen is heated will depend on the inclination of the baffle plate.

This plate is rotated by a special handle coupled to a graduated dial. The dial indicates the angle of inclination of the plate or the average temperature obtained as a result of heating the dirigible.

To improve the distribution of the heat of the exhaust gases in the dirigible and minimize losses, the temperature regulator and the heating tube must be brightly polished, inside and out. But the interior will soon be dulled, so that for the most part we shall be concerned with the shine on the outer surface, which may even be covered with a very thin sheathing material shiny on both sides. The base of the dirigible must also be shiny on the outside, and only the part covered by the heating tube should be black; in fact, the lower base itself should also be black on the inside. But the envelope of the dirigible could profitably be made shiny both inside and out.

Naturally, the parts of the bases lying closest to the temperature regulator will be subject to the most intense heating. They should be made thicker (over a short length), or, to achieve greater economy, they might be covered by a layer of some substance which will not be corroded by the combustion products.

57. The gondola has two motors, two temperature regulators, and two heating tubes. One heating tube is usually fully utilized, i.e., run at the highest temperature by closing the opening in the side of the duct. The other is used to regulate the temperature, i.e., it will sometimes be throttled down, thereby lowering the temperature, and at other times be opened up, thereby raising the temperature (depending on the requirements).

In other cases, both regulators may have to be adjusted at the

same time. On cooling, the combustion products will form water, among other things. At the lowest point of the heating tube there will be a sump to collect this water. The weight of the water (when all the combustion products undergo cooling) will be close to the weight of the hydrocarbon fuel consumed, and will be useful for maintaining the time of the dirigible, as will the variable temperature of the envelope gas.

It would be most convenient to open the forward regulator fully (i.e., to let all the combustion products flow into the heating tube). Then all the heat of the forward motor would be available for heating the dirigible, and there would be no need to exhaust combustion products in the nose section of the envelope, where their ejection might disturb the passengers and foul the dirigible. On the other hand, combustion products exhausted astern (in the tail section of the envelope by means of the other temperature regulator) would be entrained by the slip stream without affecting the gondola and its passengers.

Our dirigible will be unable to ascend unless at least one motor is working. Similarly, if both motors were to stop in flight, the dirigible would begin to sink slowly. But it is difficult to conceive of a case where both motors would stall at the same time. One of them (the one still operating) would prevent the dirigible from sinking. If both the motors were to stop, the dirigible would glide down in an inclined position, like an airplane. Its enormous surface would do the duty of wings. However, descent over a wooded area, at sea, or in unfamiliar terrain would be risky.

Ballast might be released in order to stop the descent, but our dirigible would carry no ballast (cargo which is useless in any other respect). Moreover, this ballast would have to be carried in amounts of about a ton to be useful, and it is uneconomical to store it on board. To jettison gondola equipment and fuel would be even more senseless.

But many ways could be found to avoid an emergency landing. For example, a stand-by auxiliary motor could be started up.

This seems to be the most practical approach, since it would simultaneously provide the translational motion also necessary to insure a safe descent.

While the stand-by motor drives the same propeller, the main motor could be repaired. It will occasionally be necessary to use the heat of the motors and at the same time reduce the work done by the propellers. This combination of circumstances can be successfully realized if the pitch of the propeller blades can be varied.

58. The working cylinders must also be covered with a special housing. A powerful stream of air blown through various openings, is

used to cool the cylinders evenly. The exhaust air, warmed by the cylinders, contains a comparatively small amount of heat, but may serve to heat the gondola in cold weather or at high altitudes.

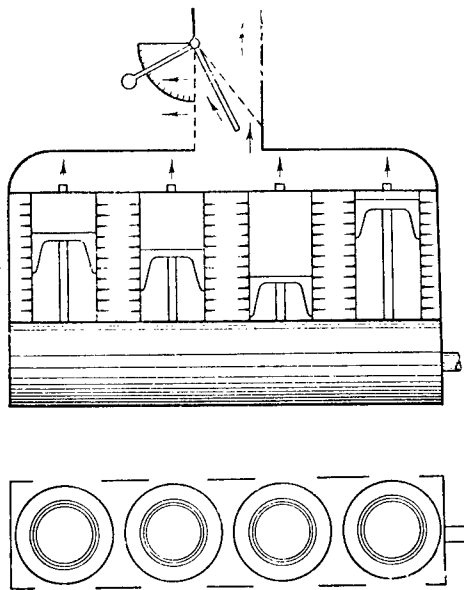

Fig. 15

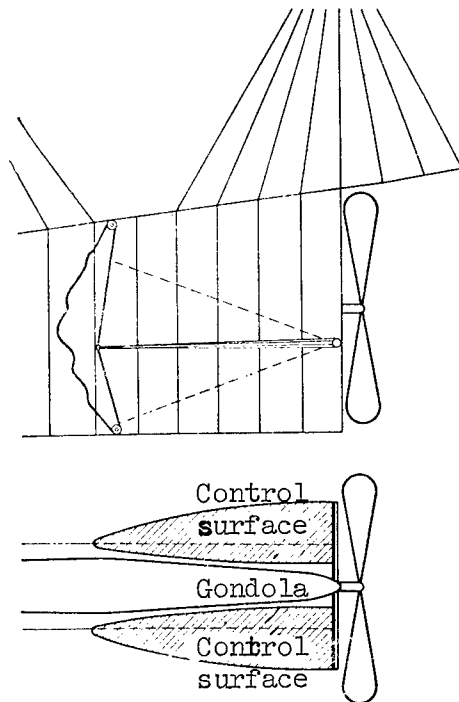

Fig. 16

59. The use of vertical control surfaces (functioning like fish tails) or horizontal control surfaces (functioning like bird tails) will be unavoidable, since they are very effective and sensitive at higher forward speeds, although it may perhaps be possible to dispense with the horizontal control surface.

As indicated in my article "Air Resistance" (printed in the journal "Nauchnoye obozreniye" [Scientific Review] in 1903), the normal

pressure on a square control surface is expressed approximately by

the formula $P = 0.021 i S v^2$, where P is the wind load in kg; i is the angle of inclination of the wind with respect to the control surface in degrees, not exceeding 10 to 15° ; S is the area of the control surface, in square meters, and v is the flow velocity or the speed of the dirigible in meters per second. The density of the medium is assumed to be 0.0012 times the density of water. Assuming $S = 6 \times 6 = 36$ square meters and $v = 22$ m/sec for our dirigible, we find $P = 366i$. This means that when the control surface is inclined at 1° to the direction of flow, the pressure on the control surface (normal to the surface) will be 366 kg. When the inclination is 10° , the pressure will be greater than 3 tons. This will constitute about one eighth of the entire maximum lift force acting on the dirigible. A comparable inclination of the propeller axis could never yield a vertical component of this magnitude. For instance, according to the tables published in my article "28th year of the dirigible" (unpublished), we find that at the same speed (22 meters per second) the pressure on all the propellers of our dirigible is 509 kg. For a 1 -degree inclination of the propeller axis, the perpendicular component will be about 9 kg, whereas at 10° it will be about 90 kg. This is 40 times less than 3660 kg.

Nor will other methods be able to compete with control surfaces in rapidity of response.

The action of a control surface is especially advantageous not only if the surface is inclined, but also if it is curved. Such a control surface is shown in Fig. 16 in plan and elevation. This type of surface is hardly more complicated or heavier than a flat surface. It is, of course, more advantageous to place it aft of the forward propeller.

The control surface consists of a framework of flexible steel rods with some lightweight material (or corrugated metal) stretched between them. In operation the tip of the surface is raised or lowered by means of special cables. Since it is located close to the gondola, such a mechanism can be constructed without much trouble. A control surface of this type can dispense with hinged joints of any kind. Its flexibility is the important factor.

Wherever possible the control surfaces should be positioned aft of the propellers. Then their effectiveness will be enhanced by the air stream generated by the propellers. Such a control surface will be particularly useful at the start of the dirigible's translational flight, before it reaches a speed high enough to take advantage of the normal airstream. The propeller, on the other hand, immediately develops its greatest efficiency (i.e., sets air in motion).

A forward control surface would be less effective than one positioned aft of the propeller, and only the proximity of the propeller and ease of construction could somewhat offset this disadvantage.

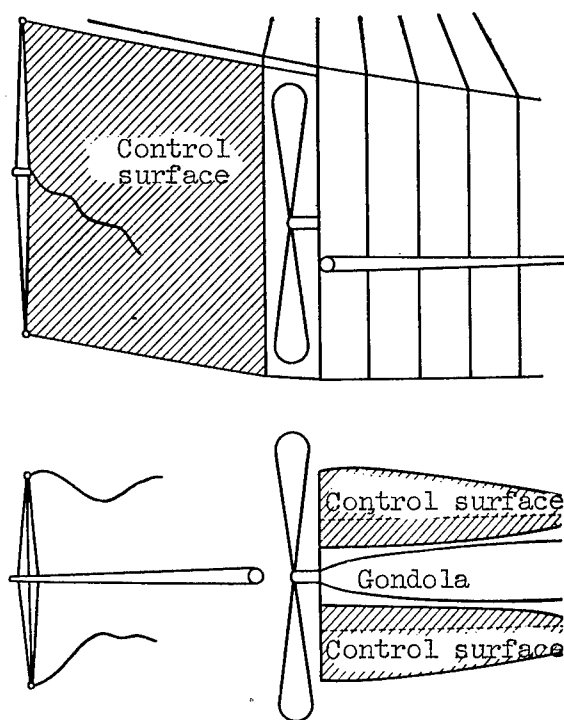

Fig. 17

We could also position the horizontal control surface aft of the stern propeller; but this is not as convenient or economical with regard to weight. By putting it in front it might be possible to increase the surface area.

In large dirigibles with a gondola extending the length of the envelope, entirely different arrangements would be required. At the beginning of forward flight, when the speed is still low and the horizontal control surface is operating at low efficiency, non-uniform tensioning of the envelope would be required to maintain horizontal stability.

If it proved impossible to do without a horizontal control surface, it would be advisable to mount it at the stern, as indicated in Fig. 17.

60. Fig. 17 gives an idea of the possible design of a flexible vertical control surface of the same size as the horizontal control surface. It features two slender rods mounted perpendicular to the surface at one end. Lightweight cables, whose function is to apply tension, thus bending the flexible surface so that pressure is exerted on it and the course of the airship corrected, are attached to the rods near the ends. In general, the construction of the two types of control surface is the same, except that the after system is somewhat heavier. On the other hand, this system will work more efficiently because it is located aft of the propeller. A horizontal control surface mounted on the other side of the rear propeller is shown in the same drawing. This will operate at a slightly lower level of efficiency than the control surface situated abaft the propeller. But the difference will be slight, and, moreover, it can easily be designed to fit alongside the gondola.

The total maximum weight of all the control surfaces has already been mentioned (in describing the table). Every effort must be made to remain within these limits in designing the dirigible.

Of course, the control surfaces may be made in the ordinary form, i.e., flat with no capability for flexing. For a variety of reasons flexible control surfaces are not suitable for waterborne vessels. They are far more practical in the case of airships.

61. Figs. 11, 13, 14, and 15 illustrate the general construction of the side walls of the gondola, its windows, doors, the mounting of the tensioning drum, the motor, and other loads.

We see how the floor of the gondola is supported by vertical hangers over 3 meters in length. Even a heavy concentrated load will not cause any distortion of the envelope shape, except for a slight compression. The point is that these gondola hangers constitute a direct extension of the members of the tensioning system. Thus, the load on the floor is transferred to two or three of the hangers supporting the gondola. These in turn transmit the load to two or three of the lower members of the tensioning system. This same load is transmitted to the lower pulley, then to the upper

pulley, and finally distributed over a considerable length of the envelope (8 meters). The corresponding lift force is not less than 800 kg. The gas pressure on this portion of the envelope will be much greater, however (about 5 tons). Thus, the compression of the envelope will be almost imperceptible.

The motors are mounted in the same manner (at the ends of the gondola). They are suspended, as it were, from the upper parts of the envelope. The braces between the frame and the floor do no more than prevent the motor from swaying from side to side.

Coarse wire netting lines the sides of the gondola to a level of one meter from the floor. It serves to prevent the passengers from falling out, should the gondola wall panels fail for any reason. Above this netting is a line of windows, each of which is one square meter in area. Still higher lies the roof, to keep out the wind and eliminate excessive drag. Doors, also protected by netting and covered with windproof material, are inserted between the windows.

62. Fig. 18 also shows two safety valves in the top of the envelope. One is closed, the other is open allowing gas to escape in the direction of the arrows. The drawing is schematic. The valve is reminiscent of a stove damper and is located at the surface of the dirigible, at the end of the upper base. Only the rod controlling the movement of the damper projects outside. Its action is facilitated by rollers. The edges of the damper enter an annular groove filled with a seal of nonfreezing liquid (high-grade rubber could be used instead). The effect of the weight of the valve and the action of a spiral spring (around the central rod), not shown in the drawing, keep the valve closed. The use of a weight instead of a spring would be effective, but uneconomical. Actually, for safety's sake the valve is positioned near the stern of the dirigible, at a point where the gas pressure is about 24 kg/m^2 . If the complete set of valves presents a total surface area of one square meter, then a load of far more than 24 kg , say 50 kg , will be required. This amount of dead weight is uneconomical. Springs would provide great savings.

How the valve operates is perfectly clear. When the overpressure inside the dirigible is much higher than the preset valve and there is danger of the envelope bursting, it will overcome the weight of the valve and the resistance of the springs and raise the valve, thereby permitting gas to escape. But the dirigible should never come to this pass in the first place. In response to the slightest increase in pressure above normal the dirigible should be made to lose height by means of the temperature regulator, or the pressure should be reduced by means of the tensioning system. The same procedure is used, moreover, whenever the overpressure falls below the proper range, i.e., the overpressure can be restored immediately by the same methods.

63. The fuel, weighing several tons, must not be concentrated at a single point, since this would impose serious stresses on the bases. It must be distributed over the entire length of the gondola in a single long tank slung underneath the gondola and divided up by partitions.

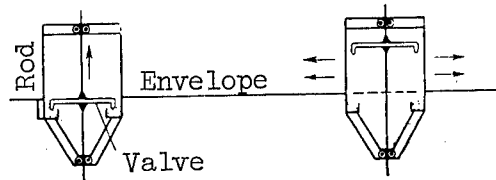

Fig. 18

This fuel tank might even replace the heavy beam under the gondola floor and would prove highly economical in that respect.

The gondola is 72 meters in length. If the fuel supply is assumed to be 5000 liters, the cross-sectional area of the fuel tank will be less than 7 square decimeters, and the diameter of the cross section less than 30 cm. Because of the low gondola bending stresses, elastic flexure of the tank will be completely assured, even if there are no transverse corrugations (so-called flexible tubes). Moreover, the tank could also have an oval or rectangular cross section.

Longitudinal corrugations would provide enormous rigidity for both the fuel tank and the gondola, together with considerable savings in weight.

The weight of the tank, if 1-mm steel plate of density 8 is used, will be 7 kg per meter. The weight of the light fuel will be about 50 kg per meter.

Thus, the weight of the tank will comprise about 1/7 of the fuel weight. This is not much, if we remember that the tank replaces a beam weighing not less than 5 kg per meter.

64. The power developed by the motor cannot be transmitted directly to the propeller because of the large diameter of the latter.

This is an inconvenience. A chain drive or gear system will be required. The propeller circle is actually about 18 meters.

The dirigible travels at a speed of roughly 30 meters a second. This means that the tip speed of the propeller will be approximately 45 meters a second. Thus the propeller has to make only 2.5 revolutions a second. But it is important that the engine turns at from 50 to 100 revolutions a second. This means that a gear system with a transmission ratio of from 1:20 to 1:40 will be required. No such gearing would be needed if old diesel engines were used, but this would involve heavy weight penalties.

Modifications and Simplifications

65. In my proposals I have taken the liberty of making various simplifying assumptions. Thus, both halves of the envelope have been assumed identical, i.e., the nose and the tail are identical in size and shape. This means that the envelope will be symmetrical about the center section.

No such symmetry will be possible for larger and more sophisticated dirigibles: the front of the envelope will be blunter than the stern. The drag will not be greatly reduced thereby, but the stability and ease of maneuverability will be much enhanced.

66. Moreover, the lower base, or the bottom strip of the flat envelope, must be made more convex; otherwise the top part of the envelope will be more convex than the bottom when the envelope is inflated and stretched. This depends on the two long shoulders (on either side of the furrow running the length of the top of the envelope). But we shall neglect this for the time being.

This irregularity (asymmetry) will cause the nose of the dirigible to drop, which will offset the action of the propeller, the effect of which is to raise the nose. Thus, the asymmetry may prove quite useful. To what degree it will be useful can only be determined by experiment. But we can always achieve correct horizontality by tightening the envelope.

67. Let us take a fairly blunt-nosed dirigible as an example: its aspect ratio is 4 in the flat form, and about 6 in the inflated

form. Our object is to enhance the horizontal stability and simplify the tensioning system.

68. The end of the dirigible cannot be designed in accordance with the formula: it must be conical to at least 0.1 of the semiaxis from the end*. The table gives the derivative for a flat envelope, or the tangent of the angle formed by the curve with the horizontal. Clearly, from Fig. 3, the ordinate of the end must be (cf. rows 6 and 8 of the table) $4.317 - (0.515 \cdot 6) = 1.23$ meter.

From the ordinate corresponding to the abscissa $(0.9 x_1)$, we subtract the product of the segment $0.1 x_1$ or 6 meters and the tangent of the angle. This means that the terminal rectangle will be 2.46 meters high. If the ends of the envelope are extended by a fraction, they will become 2 meters high, i.e., equal in height and breadth or square. But there is no need to do this.

69. In the more sophisticated large dirigibles the gondola will extend the entire length of the envelope. The upper base of the envelope will also be fully accessible. The propellers and motors, however, will be differently arranged. In large dirigibles the number of both motors and propellers will be increased.

V. SEQUENCE OF PRACTICAL OPERATIONS IN THE CONSTRUCTION OF A METAL DIRIGIBLE

I assume the sequence of operations in the construction of a metal airship to be as follows.

1. The construction of scale models of a dirigible which do not fly and cannot vary their shape or volume. The dimensions are 5 to 30 cm in height and 30 to 180 cm in length. Apart from the corrugations and the other comparatively fine details, the scale is constant, and the design similar (the last of several such models so constructed [a dirigible with a volume of 3,000 cubic meters] is shown in the photograph in Fig. 19 [see also the 8,000 cubic meter models, Figures 20 and 21]).

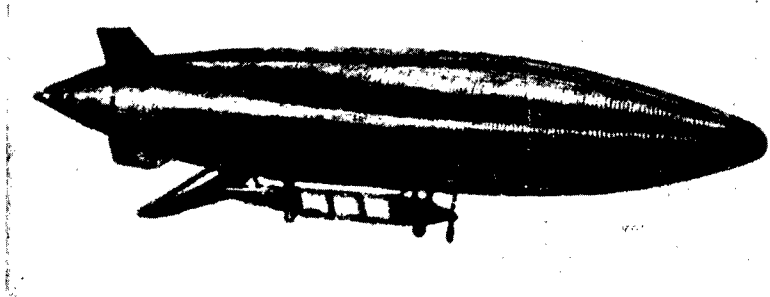

Fig. 19.

2. The construction of partially elastic nonflying models, i.e., models capable of varying their volume and shape slightly without being deformed. The dimensions are 30 to 100 cm in height and 180 to 600 cm in length. The scale is variable. Exact similarity

is not observed (caricature). The envelope alone is built. One of these models (in brass) [1924] was only 30 cm in height and almost completely elastic.

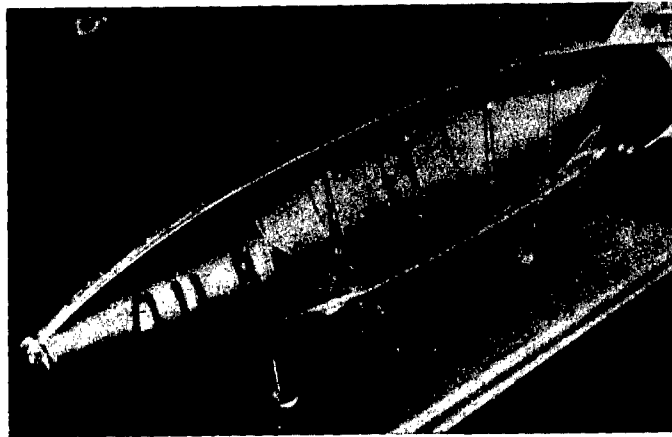

Fig. 20.

3. Models of nonflying envelopes which are capable of varying their volume and folding flat without suffering any deformation. Such envelopes may be completely deflated and then reinflated an infinite number of times with no deterioration. The proportionality or similarity to a real envelope is more faithfully observed. The dimensions are 1 to 4 meters in height and 4 to 16 meters in length.

Fig. 22 is a picture of a brass model (in the flat form) one meter high and 4 meters long, fabricated by the author in 1925; the picture is taken in the author's garret. The side wall is 0.1 m thick. A second elastic bronze model measuring 10.2 by 0.3 meters in the flat form with side walls 0.15 mm thick was constructed in 1926 on the basis of my drawings. It was assembled for the first time without raising the envelope, by a method which is a simplified version of that described below (cf. section 6 and Figures 31 and 32).

In 1931, the first electric-welded elastic envelope, one meter high and 6 meters in length, was built. Its side walls and

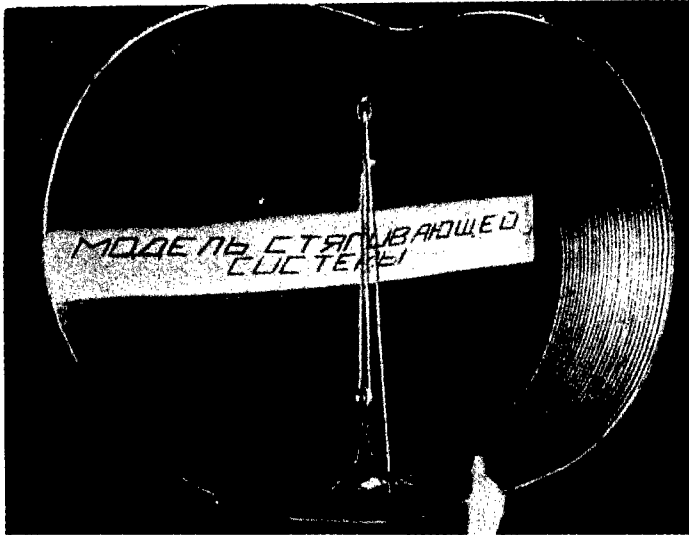

Fig. 21

[sign reads: Model of Tensioning System]

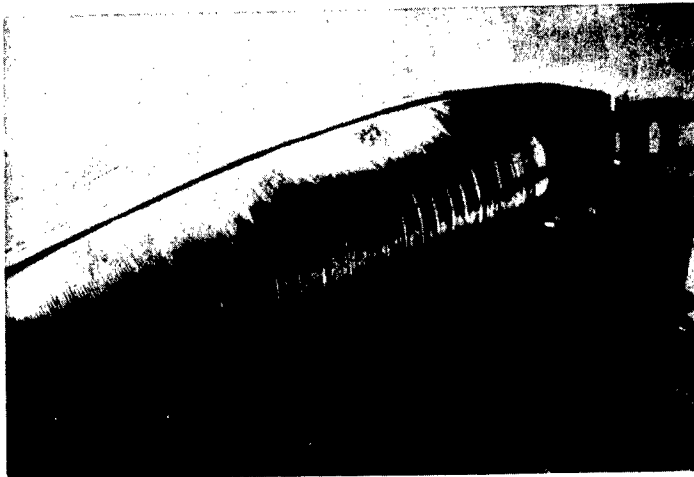

Fig. 22.

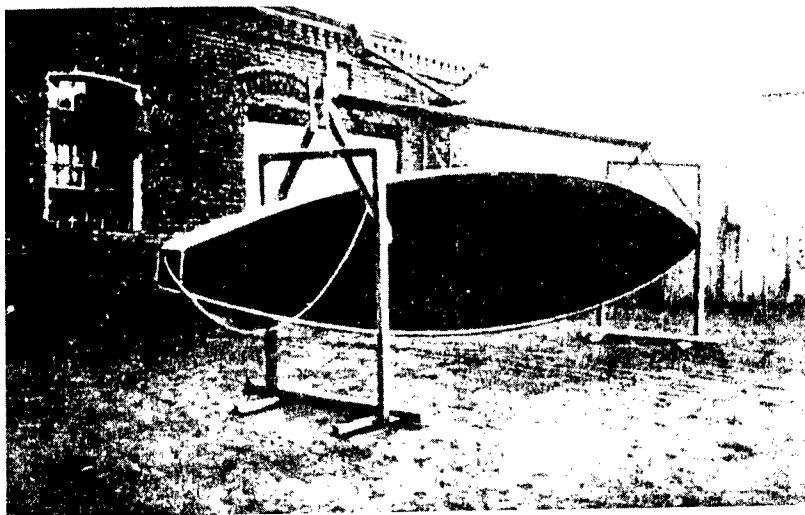

Fig. 23.

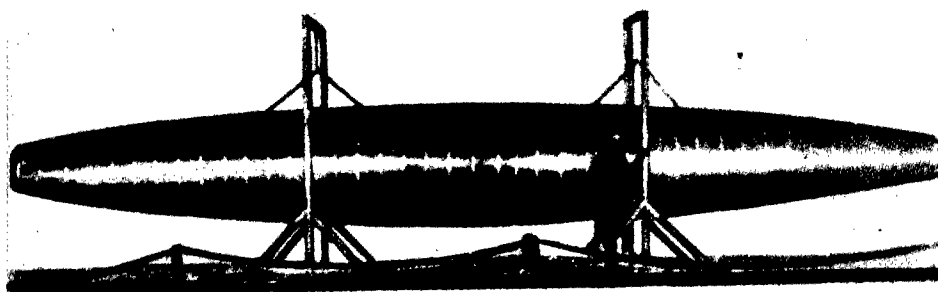

Fig. 24.

half-tubes were made of carbon steel 0.1 mm thick, while the remaining parts were made of stainless steel 0.2 mm thick (Fig. 23). The lack of mobile welding machines forced us for the time being to resort to reversing the envelope during assembly, something which could not be done in assembling an airship envelope.

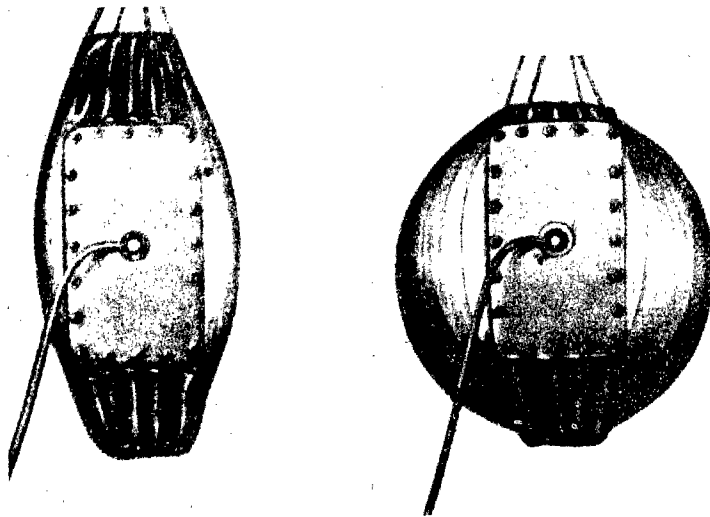

Fig. 25.

The first all-welded stainless steel envelope was built in 1933; it measured 11.3 meters in length, but in other respects had the same dimensions and order of assembly as the 1926 model.

A general view of this envelope is shown in Figures 24 and 25. We see the envelope in two stages of inflation, 10 and at 200 mm Hg respectively.

4. All the components are full size, including: the corrugated surface of the envelope side walls, the hinged joints, the pulleys,



Fig. 26.



Fig. 27.

cables, gondola components, control surfaces, temperature regulators, tensioning drums, safety valves, etc.

5. Machinery for the rapid, high-precision, and inexpensive fabrication of full-size components. Here, among others, I have in mind welding, corrugating, pressing, and rolling machines of different sizes, function, and design.

Figure 26 shows a compressor used in checking the tightness of the seams, against a background of an assembled envelope, and Fig. 27 shows the process of checking the seams of an inflated envelope.

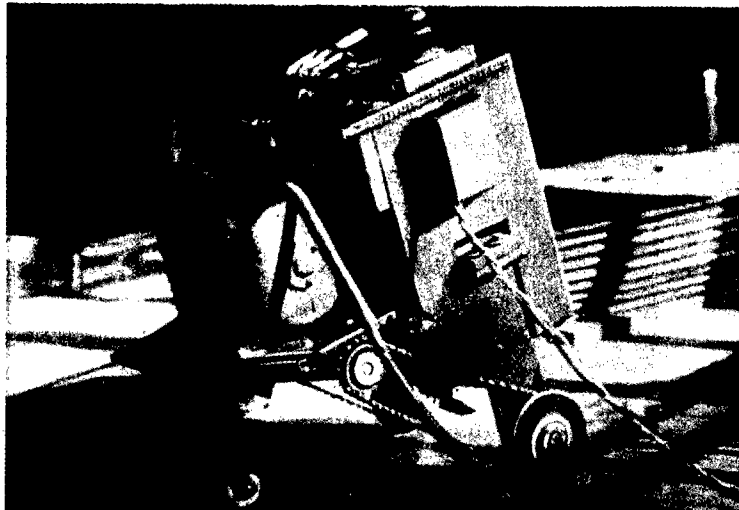

Fig. 28.

Figure 28 shows a model of a mobile "two-wheeler" welder for the electric welding of panels of any size. In the rear we see an envelope 11.3 meters in length, fabricated solely with the aid of this model. The subsequent "velocipede" type welding machine for welding locked envelope seams is shown in Fig. 29.

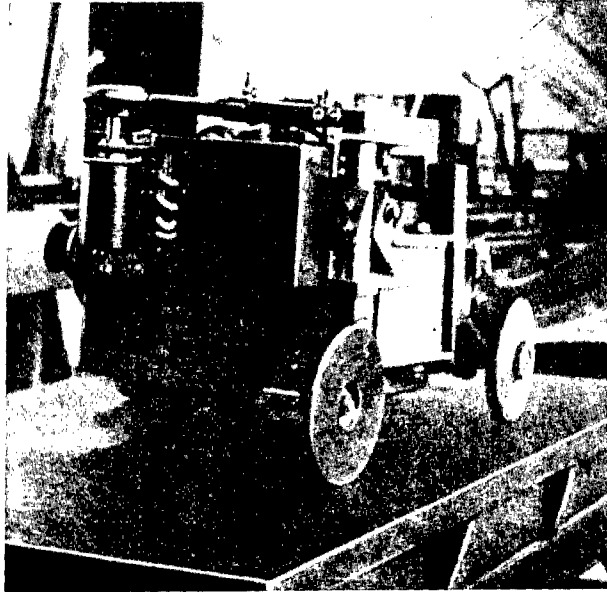

Fig. 29.

Fig. 30 shows the arrangement of lever-type strain gauges for studying the stressed state of the bases (longitudinal strips or bands) in corresponding various levels of the gas pressure in the envelope.

6. Docks for the construction of gondolas and metal envelopes. A gondola drydock consists of stands of moderate height from which the gondola is suspended and which provide scaffolding for its construction. The dock for the envelope is a more or less flat and horizontal platform, or even a smoothed and cemented dirt surface.

Figure 31 shows the layout of an envelope drydock in plan form. The thick lines across the envelope indicate the outlines of individual sections of the side walls.

The bases (longitudinal strips) are assembled on long tables at each side, and the squares at the ends of the envelope show where the nose and tail pieces are preassembled.

The dots around the envelope represent short columns for

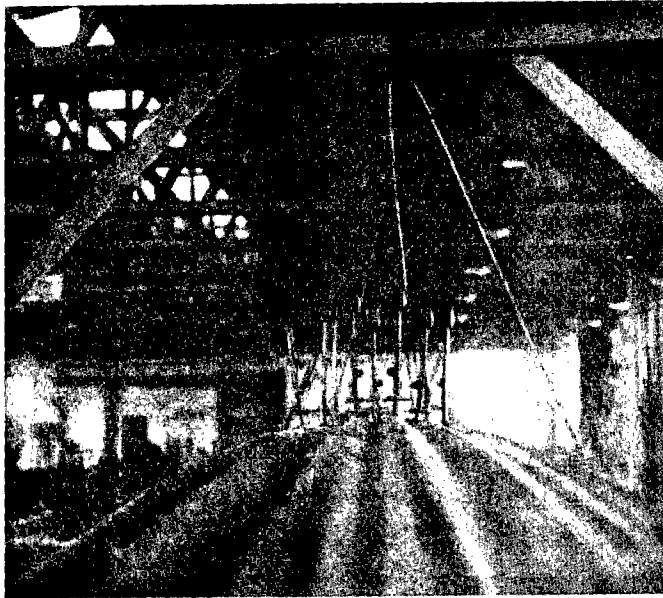

Fig. 30.

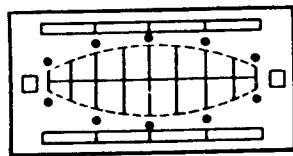

Fig. 31.

raising the envelope during inflation and hoisting operations.

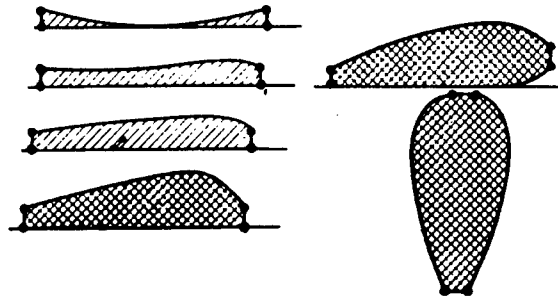

Fig. 32.

Figure 32 shows, in cross section, successive stages in inflating the envelope on a flat, slightly inclined platform, based on studies of air-filled models immersed in a tank of water.

The dead space in the deflated envelope with collapsed side walls (top figure) is flushed out with hydrogen, after which the inflation operation commences. When the amount of gas is almost sufficient to lift the envelope, the envelope rises automatically into the vertical position. Then the envelope is filled up and checked out, after which the gondola is suspended from it.

7. Flying envelopes of simplified design, with no gondola attached. 2 to 6 meters in height, 8 to 18 meters in length.

Figure 33 shows an all-welded flying envelope 1,080 cubic meters in volume and 7 meters in diameter, made of steel 0.1 mm thick and measuring 0.36 to 11.44 meters when assembled, undergoing static tests. The building of the envelope was completed on September 15, 1935, 4 days before K. E. Tsiolkovskiy died.

8. Models of flying dirigibles carrying a gondola plus a small load in the form of simplified control elements, but no crew or passengers, slightly larger in size than the previous

models.

9. Dirigibles capable of carrying 1 to 5 people. These are simplified, very flimsy in construction, impractical, and offer no significant advantage. They are built solely to gain experience in construction. They measure 7 to 10 meters in height and 28 to 30 meters in length.

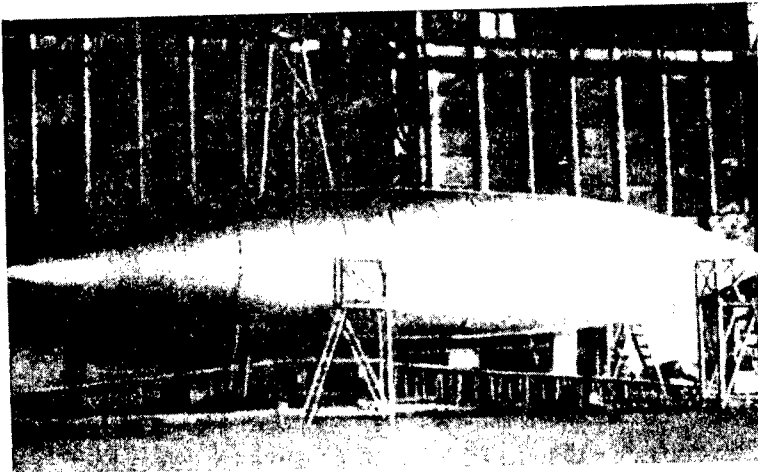

Fig. 33.

10. Dirigibles of less flimsy construction, easily controlled and maneuverable, but even less practical and less economical. They measure 10 to 15 meters in height and 40 to 75 meters in length. They are capable of carrying 5 to 15 people. The construction is almost complete, with a few minor simplifications.

11. Practical dirigibles. The larger these are the more effective and economical they will be. Completely equipped. 15 to 50 meters in height and 90 to 300 meters in length, reaching the proportions of an ocean liner. Capable of carrying anywhere from 17 to 1,000 persons.

The theoretical limits of dirigibles, given the present state of the art, extend to 300 meters in height and to a passenger and crew capacity of 200,000 persons.

The air leviathans would be comparable in height with the Eifel Tower.

The first three steps have been taken already. If this has not been done in an entirely satisfactory manner, the reason lies in the inadequacy of the materials, lack of experience, and defects in the equipment. Equipment for welding envelope components is now being fabricated (the completed models have been scattered over various sites, in some cases damaged during transportation or while on display at expositions; in general, it would be advisable to rebuild them from scratch).

The fourth operation has already been begun and should not be delayed as the material conditions are favorable. This involves pattern work based on working drawings and tables.

The fifth step is a highly important one, since on it depend the speed, costs, and quality of construction. It would be desirable to complete this stage before beginning the construction of practical airships (even though such airships could be constructed without the aid of specially devised machines).

Using known means of improving dirigible parts, we could use these data to fabricate the corresponding machinery. Foreign designers might be of some help here, but the problem is so simple that, it seems to me, we could get along perfectly well with our own.

The construction of flat docks and small gondola docks (sixth step) presents no problems.

The next or seventh step -- the construction of flying models -- is a rather delicate matter, but is entirely realizable given the availability of sufficiently thin materials and the appropriate technical means.

The next steps (eighth through eleventh) could be taken quite rapidly after the fifth, since everything depends on the machinery available (i.e., speed and quality). The aerostat components are neither intricate nor irregular, so that the production of the proper machine tools would present no great difficulties.

The gradual nature of the steps in question not only frees us of exorbitant expenses and unproductive effort, but also goes a long way to simplifying the construction of large practical dirigibles. This preparation, which costs practically nothing as far as materials are concerned, frees us of the burden of costly errors and failures.

The completion of the first step gives us a general idea of the shape and layout of metal dirigibles made of corrugated

metal, as well as some idea of the relative dimensions of the dirigible and its constituent parts. This is primarily an artist's concept of the airship.

The second stage demonstrates the possibility of constructing a metal envelope capable of varying its volume and shape without detriment to the integrity of the dirigible. The third step illustrates the same possibility, but more thoroughly. The fourth step constitutes a preparatory step toward the construction of the necessary machine tools. It will also provide some idea of the natural size and strength of the principal parts of the airship. The gondola and controls will be almost complete in form and built to full scale.

In the fifth stage, we strive to simplify the parts and the machine tools required to produce them. This could save quite a bit of time.

In the seventh step the aim is to construct a simplified flying model. This stage must be gone through, since it gives us a clear picture of the relationship between the strength of the envelope materials, the gas pressure and the gravity loads. It may also give the first practical hint as to the true stability of the dirigible.

The remaining step serve as preparatory stages for the accumulation of experience and the avoiding of unnecessary effort, expense, and loss of life.

A dirigible is an enormous undertaking and its usefulness is in no way limited to military purposes. It deserves attention and serious work. This is beyond the powers of a single individual or a single specialty.

The work of building dirigibles must be distributed among experienced, knowledgeable, dispassionate, young and vigorous workers roughly as follows.

1. Materials selection and testing.
2. Rolling of sheet, rods, etc.
3. Punching and stamping of sheet metal.
4. Wires and cables.
5. Electric welding.
6. Oxyacetylene welding.

7. Flat drydock for constructing dirigible envelope.
8. Hinged joints.
9. Tensioning system with special motor.
10. Safety valves.
11. Low dock for gondola.
12. Gondola flooring.
13. Main gondola rods, safety netting, sheathing, windows, doors, and passenger accommodation (heating, armchairs, bunks, provisions, etc.).
14. Propeller-motor unit with temperature regulator and heating tube.
15. Vertical and, if required, horizontal control surfaces.
16. General assembly of dirigible envelope.
17. Supply of hydrogen.
18. Inflating envelope with gas and coupling envelope to gondola.
19. Mooring masts and mooring towers.
20. Control of dirigible in flight.
21. My general supervision through the intermediary of Comrade Rapoport.

All participants in the project should be familiar with the overall plan.

Model makers must make models of the complete dirigible and its parts for the visual training of their co-workers.

4. COMPENDIUM OF THE CORRUGATED STEEL DIRIGIBLE*

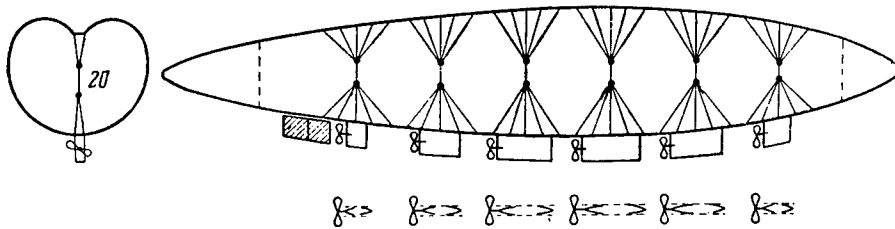

Fig. 1.

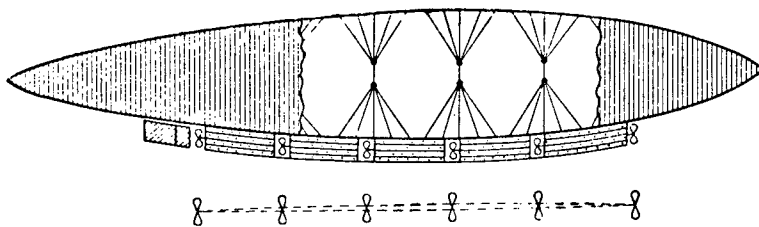

Fig. 2.

*1931. In order to minimize repetition we have reproduced, with new numbers, only Figures 18-27 from Tsiolkovskiy's previous works. Cf. editor's notes at end of book.

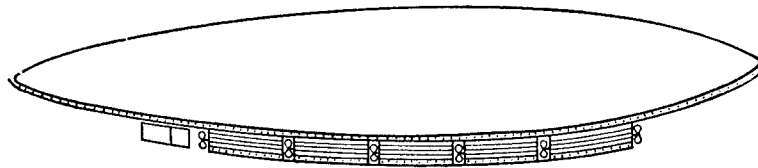

Fig. 3.

Fig. 1 - Fig. 3. Old projects. Longitudinal and transverse sections and view of gondolas from below.

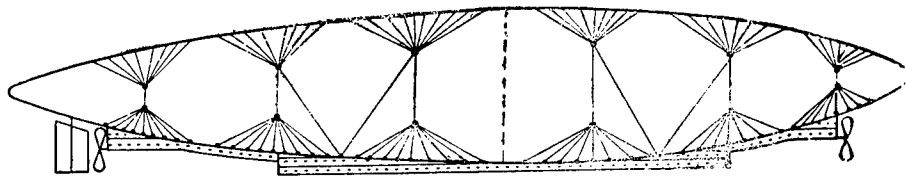

Fig. 4.

Longitudinal section through a 200-man dirigible.

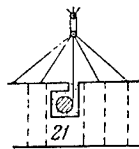

Fig. 5.

Housing for tensioning drum.



Fig. 6.

Floor of gondola.

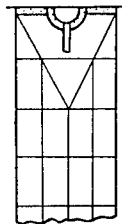

Fig. 7.

Transverse section through
multistory gondola.

I. GENERAL TABLE FOR DIRIGIBLES 60-300 METERS IN LENGTH

	10	15	20	25	30	40	50
1. Height of fully inflated envelope, not counting bases							
2. Maximum width of flat envelope during construction.	15.7 60	23.55	31.4	39.25	47.1	62.8	78.5
3. Length of envelope or dirigible.		90	120	150	180	240	300
4. Width of envelope bases or longitudinal strips.	1 1400	1.5	2	2.5	3	4	5
5. Surface area of corrugated envelope		3150	5600	8750	12 600	22 400	35 000
6. Surface area of the two bases.	122 1522	274	488	762	1098	1952	3050
7. Total surface area of gas bag.	2150	3424	6088	9512	13 698	24 352	38 050
8. 3/4 of total volume of gas bag.		7240	17 190	33 500	58 000	137 400	268 000
9. Lift force of dirigible with weight of gas subtracted.	2570 5	8690	20 600	40 220	69 530	164 600	321 800

[Table continued next page]

[Table continued]

10. Number of persons carried by dirigible.	17	39	76	131	312	610
11. Surface area of gas bag per person carried.	304	201	125	104	78	63
12. Area of maximum cross section through envelope, neglecting bases and depression in top.	78.5	314.2	490.9	706.9	1257	1964
13. Same area reduced 25 times.	3.14	176.7	19.64	28.28	50.3	78.5
14. Same but divided by the number of persons carried.	0.63	7.08	0.26	0.22	0.16	0.13
15. Total power developed by motors.	24	82	381	659	1560	3050
16. Weight of two motors, assuming one metric work unit per 10 kg.	240	820	3810	6590	15 600	30 500

[Table continued next page]

[Table continued]

17.	Weight of two motors, assuming one metric work unit per 1 kg.	24	82	195	381	659	1560	3050
18.	Pressure of air stream on dirigible, or pressure on all propellers.	80	236	509	921	1488	3218	5849
19.	Speed of dirigible, per second.	17.2	19.7	21.7	23.3	25.0	27.5	29.5
20.	Horizontal speed of dirigible in km/hr.	62	71	78	84	90	99	106
21.	low point	6	9	12	15	18	24	30
22.	Pressure of gases inside envelope per square meter	12	18	24	30	36	48	60
23.	High point	18	27	36	45	54	72	90
24.	Total longitudinal pressure of gas on maximum cross section through envelope	942	3179	7536	14 719	25 434	60 288	11 775

[Table continued next page]

[Table continued]

25.	Total longitudinal tension of corrugated envelope at the maximum cross section.	319	717	1276	1994	2871	5104	7975
26.	Longitudinal tension of bases at maximum cross section*	530	1785	4240	8275	14 310	33 900*	66 350
27.	Bottom	410	1395	3300	6450	11 130	26 400	51 500
28.	Transverse tension of envelope at maximum cross section per linear meter of longitudinal section	53	119	211	330	475	845	1320
29.	Middle	60	135	240	375	540	960	1500
30.	High Point	67	151	269	420	605	1075	1680
31.	Thickness of corrugated envelope and of material of half-tubes, mm.	0.1	0.15	0.2	0.25	0.3	0.4	0.5

* A misprint [42,400] appeared in the original.

[Table continued next page]

[Table continued]

32. Thickness of longitudinal bases and hinge material, mm.	0.3	0.45	0.6	0.75	0.9	1.2	1.5
33. Minimum longitudinal strength of dirigible envelope.	46	30	23	18	15	11	9
34. Minimum transverse strength of dirigible envelope.	99	66	50	40	33	25	20
35a. Total depth of envelope corrugations, cm.	0.5	0.75	1	1.25	1.5	2	2.5
35b. Length of corrugations, cm.	1.35	2.025	2.7	3.375	4.05	5.4	6.75
36. Width of strip for fabricating hinge leafs of hinged joint, cm.	5	7.5	10	12.5	15	20	25
37. Width of strip for half-tubes, cm.	4	6	8	10	12	16	20

[Table continued next page]

[Table continued]

38. Weight of one square meter of envelope with 10% added for weld metal and corrugations, kg.**	0.825	1.238	1.650	2.062	2.48	3.30	4.12*
39. Width of gondola floor.	1	1	1	1	1.5	2	2
40. (Minimum) height of gondola.	3	3	3	4	4	5	6
41. Number of floors in gondola.	1	1	1	1	1	1	2
42. Diameter of each propeller.	3	4	6	8	10	12	14
43. Length of gondola.	60	90	120	150	180	240	600
44. Floor area of gondola.	60	90	120	150	270	480	1200
45. Floor area divided by number of persons carried.	12	5.3	3.1	1.98	2.06	1.54	1.97

**A misprint [4.18] appeared in the 1931 edition.

[Table continued next page]

[Table continued]

482

46. Average thickness of one of 120 wires of tensioning system, mm.	1.5	2.7	4.1	5.6	7.4	11	16
47. Average tension in a single 10-pulley system.	20	68	160	310	540	1300	2500
48. Maximum height of longitudinal girders, corrugations, half-tubes, heating tubes, etc., cm.	6	9	12	15	18	24	30
49. Average cost of dirigible, Russian gold rubles.	3300	11 100	26 300	51 300	88 700	210 000	411 000
50. Useful work done by dirigible in one-year period, assuming 5,000 hours of flight time only per year; as the unit we assume a 100 kg load (see section 6) hauled over 1,000 km.	0	2840	11 310	26 800	52 200	144 540	310 050
51. Cost of this work, assuming each payment per km, in gold rubles.	0	28 400	113 000	269 000	522 000	1 445 000	3 100 000

II. NOTES ON USE OF TABLE

1. Height of inflated envelope, without bases, in meters. The bases will increase this height, but since the dirigible is filled to only $\frac{3}{4}$ of its maximum volume, the true height of a dirigible on the ground will be even less than the figure given. The greatest height given in the table is 6 times less than the height of the Eifel Tower and twice the height of a full-grown pine tree. Note that the figures in the table represent meters and kilograms where other units are not specified.

The height of the dirigibles is astounding; but to begin with we shall construct small ones, proceeding gradually to the larger sizes; secondly, the construction work is done on a horizontal surface; this is not only convenient, but the reader will also note that a dirigible on the ground will not frighten anyone with its size. When completely inflated with hydrogen the dirigible will hang suspended. In general, one should remember that all parts of the dirigible are suspended, i.e., they are in tension and not in compression, as would be the case with a ship, for example. This is a tremendous strength-enhancing factor, minimizing the weight and greatly simplifying construction.

2. The maximum width of a flat envelope under construction before inflation; it is 1.57 times greater than the first row of figures. The construction platform must be 30 % broader, to accommodate the bases.

3. Length of dirigible. The platform is slightly longer. The length of the largest dirigible is comparable with the length of an ocean liner, and the height is slightly greater than the width of such a vessel. The length of the dirigible is six times its height. Zeppelins of this size are already being built.

4. The width of the envelope bases. This comprises 10 % of the envelope height, and ranges from 1 to 5 meters. It is more advantageous to make the bases wider in the middle than at the ends. The longitudinal strength increases one and a half times and the lift force shows a three percent gain. The bases are assumed rectangular and of uniform width. They are the same length as the envelope.

5. Surface area of corrugated envelope. This surface area

is three times that of the center longitudinal section.

6. Surface area of the two bases. This comprises 11.5 % of the area of the corrugated side walls.

7. Total surface area of gas bag.

8. $3/4$ of total volume of gas bag. Inflation to 75 % will enable the dirigible to rise an altitude of 2 km and to hover, if necessary, at that altitude, with no loss of gas in the ascent. The volume of the largest dirigible listed here is twice that of the planned giant zeppelin. The average metal dirigible is comparable in volume to a zeppelin of 50,000 cubic meters.

9. Lift force of dirigible. The air density is assumed to be 0.00129, gas density 0.00009, i.e., 14 times less. This is for the case of hydrogen. The lift force per cubic meter is 1.2 kg. It is, of course, less at high altitudes and at above-zero temperatures, and greater below sea level and in below-zero weather. It also increases as the atmospheric pressure increases. The lift force is equal to the weight of the dirigible and all its contents exclusive of the gas.

10. Number of persons carried on board the dirigible. This ranges from 5 to 610 persons. 100 kg allows for one person and baggage. The weight of all the passengers and baggage is assumed to be one-fifth the lift force, i.e., 20 %. The crew will not number less than nine; the aerostat, consequently, may carry only eight passengers in the case of an envelope 15 meters high, and some profit may be expected. The crew will be relatively less numerous on large dirigibles, so that these will yield greater profits.

11. The surface area of the dirigible per person carried. This varies from 304 to 63 square meters and expresses the relative friction or resistance encountered by the envelope in its motion per passenger or crew member. The surface area of both sides of the wings of an airplane is not less than 30 square meters, while the fuselage presents no less than 20 square meters of external surface. This means that the friction alone on an airplane is close to the friction on the surface of a dirigible 50 meters high. But the aeroplane creates an enormous drag due to the struts and other projecting parts almost completely absent from a dirigible. Moreover, the airplane expends a great deal of energy in keeping itself aloft, i.e., in counteracting gravity, which is no problem for a

dirigible. On a large dirigible, 63 square meters of metal sheet enclosing hydrogen will carry a passenger or crewman and the corresponding part of the gondola together with all the controls. These 63 square meters are equivalent to the surface of a cubical carriage with sides about 3 meters long.

The surface area per passenger or crewman will always enclose 400 cubic meters of hydrogen. This will do the job of carrying one man with all his requirements, his baggage, and the motors, 400 kg of inexpensive metal, and the same 400 cubic meters of gas will support and carry the man and his baggage indefinitely. The 400 kg mentioned include the envelope, the gondola, the controls, the power plane, and everything else required.

12. The area of the maximum cross section through the envelope, ignoring the bases and the depression in the top. The true area is slightly less. It also expresses the drag opposing the motion of the dirigible. But the envelope tapers, so that the true resistance will be at least 25 times lower. This area is 19.4 times less than the surface area of the dirigible, or 5.6 % of the latter. The area of the principal longitudinal horizontal section is less than the surface area of the envelope by a factor of three, if we ignore the bases. This section expresses the resistance to the vertical motion of the envelope.

13. The previous figures reduced 25 times. They express the drag experienced by the dirigible in its translational motion.

14. The same areas divided by the number of persons carried on board, i.e., the drag per passenger or crewman. This factor is very small and decreases as the size of the dirigible increase. In the case of a large dirigible it will be less than the resistance experienced by a man skating on ice, or in general by a man moving through still air at the same speed as the dirigible. But since the speed of a dirigible is considerable, we assume about 7 hp per passenger to overcome the atmospheric drag. At first glance it seems strange that the relative drag on a large dirigible should be less than the resistance offered to a human body. But the latter need not be considered at all when the passengers are actually on board, for they will be shielded from the wind by the gondola with its extremely low drag.

15. The total power of all the airship's motors, taking $\frac{4}{3}$ hp or 100 kg/sec as the unit. It amounts to 3 thousand metric units or 4 thousand ordinary units, whereas an airplane carrying two passengers requires 150 units, and a one-seater airplane re-

quires 75 units. Our large dirigible will carry about 600 passengers. This means only 7 hp per passenger, or one-tenth that amount.

The determination of the power is based on a long series of calculations and experiments on drag. The power is modest, since the hull and the gondola of the dirigible are smoothly shaped with no folds or irregularities. The high and slender gondola serves excellently as a keel, while horizontal control surfaces will prove to be almost superfluous, as we shall see. The resistance offered by the medium is consequently minimal.

16 and 17*. The weight of the motors. We assign a much larger weight to dirigible motors than to airplane motors, in fact, almost ten times as much. On the other hand, good performance and long service life are to be expected from these motors. Moreover, this can be achieved even if the motors weigh 5 kg each per metric unit. The figures listed here can then be halved. In practice, though, following the example of airplanes, we may reduce the weight of the motors on the largest dirigible to 3 tons.

We assigned 10 % of the total lift force to the motors, but if light-weight motors are used only 5 % or even a figure as low as 1 % of the lift force need be made available for them. These last motors will, of course, be less reliable than airplane motors. However, the failure of airplane engines threatens worse consequences than the failure of dirigible motors, since the former would mean a crash or a dangerous glide. Engine failure on board a dirigible would also require a landing; but, firstly, the landing would not be absolutely inevitable, and, secondly, it is difficult to conceive of a situation where both motors failed simultaneously. Stalling of one motor would hardly be noticed, so that lightweight motors would be of far greater value to a dirigible than to an airplane.

18. The pressure exerted on the dirigible by the air stream; it is equal to the pressure on all the rotating propellers and comprises only 3.3 % of the total lift force; it is therefore 30 times less than the lift force, or 6 times less than the weight of passengers and crew, since these account for one fifth of the lift force.

The pressure acting on the propellers as a result of their rotation and the pressure exerted by the air stream on the hull and gondola constitute two equal and opposite parallel forces, i.e., a couple. This couple must be balanced or the nose of the dirigible will rise.

19. The speed, per second, of the dirigible.

20. The speed of the dirigible in kilometers per hour. This figure varies from 62 to 106 km. There is a possibility of increasing the engine power of small dirigibles by 8 times. The speed would then be doubled and be almost twice that of an airplane. This is also possible in the case of large dirigibles.

21-23. The gas pressure, or, more accurately, the pressure difference of the gases inside and outside the envelope, per square meter; the range is 6 to 90 kg. This pressure is given for the low, middle and high points of the envelope. The pressure is the same for any horizontal plane cross section or at any height. It is proportional, in general, to the height of the gas above the low point of the envelope plus a constant pressure. This constant pressure depends on us, i.e., on the tensioning forces to which the envelope is subjected. In our case the low, middle, and high pressures bear the ratio 1 : 2 : 3 to each other. But if the tensioning is intense, a different ratio may result, for example 2 : 3 : 4 or 11 : 12 : 13. For the largest of the dirigibles listed in the table, the average pressure will be 60 kg/m². The figures given also express the gas pressure in millimeters of water column.

24. The total longitudinal gas pressure on the maximum cross section through the envelope. It constitutes 38.6 % of the lift force and is therefore quite large. Of course, it falls off rapidly toward the ends. It must be balanced by the tension in the longitudinal base strips and the corrugated side walls of the dirigible. The tension in the latter is variable, for it depends on the extent to which the envelope is inflated with gas and on the force applying tension to the envelope. Therefore the longitudinal bases are likewise subjected to a nonuniform tension. In calculating the strength of the envelope, the best procedure is to ignore the resistance of the corrugated envelope surface.

25. The longitudinal tension in the corrugated envelope. On the basis of formula (339) given in my article "Theory of the Aerostat," we can compute the tension from the data of the table and text concerning the corrugated surface. Comparing this tension with the total pressure exerted by the gas on the transverse section, we find that the elasticity of the corrugated surface accounts for at most an insignificant gas pressure in large airships: viz., 60 % for a 10-meter envelope, 30 % for a 20-meter envelope, and 15 % for a 40-meter envelope, and so forth.

Accordingly, the resistance of the corrugations may be left out of the calculations, and attention centered on the bases. However, by reducing the size and shape of the corrugations, we can increase their strength; only this reduces the elastic limit; but in our case the strength is in general excessive and may even be halved, since in practice the envelope is not folded flat. If the size of the corrugations is halved, the tension in the envelope will now constitute as much as 120 % of the gas pressure, i.e., it will greatly enhance the strength of the dirigible, especially near the ends.

26 and 27. The tension in the bases due to the gas pressure, when the strength of the envelope is neglected. The sum of both forces must equal the gas pressure. The two forces are in the ratio of 9 : 7. However, the tension also depends on the tensioning force applied to the envelope; the greater this force the closer to unity the ratio of the two tensions. The tension at other points in the bases will be the lower the closer these points lie to the ends or the smaller the corresponding cross-sectional area of the envelope. It would seem uneconomical, then, to make the strength of the bases equal throughout their length. The strength could be gradually reduced toward the ends, but not too much, since the gas pressure will increase at the ends in response to random tilting of the dirigible.

28 to 30. The transverse tension in the envelope per linear meter varies as a function of the size of the dirigible and the level of the horizontal section for the same envelope. Tension is given for the low, middle and high points. The values are in the ratio of 7 : 8 : 9.

31. Envelope thickness and material of the half-tubes. The thickness is expressed in millimeters. If the envelope is x meters high, it will be x hundredths of a millimeter thick. It is made of either iron or steel. If made of duralumin, it will be three times thicker.

32. The thickness of the bases and of hinge material will be tripled.

33. The longitudinal strength of the envelope decreases several-fold with size, if the width of the bases also increases, so that the lift force of the dirigible increases by almost the same amount, making the dirigible capable of lifting anything it could lift before.

34. Transverse strength. It is twice as great.

35a. Total depth of envelope corrugations, in centimeters.
Length of corrugations 2.7 times as much.

35b. Length of corrugations, in centimeters.

36. Width of strip from which hinges are formed. This width is 10 times the corrugation depth. The thickness of the hinges is the same as that of the bases. The strip is made double width and drilled in this form, after which it is cut in two. The two halves form a pair that is slipped over the hinge rod. The weight of the hinges accounts for 2.2 % of the total lift force. Their strength is appreciable. They account for about 20 % of the strength of the bases.

37. The width of the strip forming the half-tubes. This is 8 times the depth of the corrugations. The weight of the half-tubes is estimated at 0.26 % of the total lift force.

38. The weight of one square meter of the envelope side wall, with 10 % added to take care of weld metal and corrugations. The thickness of any type of dirigible envelope is more or less proportional to the linear dimensions of the dirigible. Thus we see that in the case of the largest 300-meter dirigible the corrugated envelope is made of material of the same thickness as roofing metal. The corrugations and welds add 10 % to the transverse strength of the envelope.

39. The width of the gondola, or the width of its floor. In the case of dirigibles 15 meters tall, the gondola will broaden out upwards in order to match the wider base of the envelope. The width must be adequate to accommodate the upper berths and suspended seats. There will be enough room for free circulation.

40. Minimum height of gondola; because of the curvature of the dirigible in the direction of both bow and stern, the gondola will be taller at the ends, allowing for the possibility of installing large-diameter propellers at these points. This will make it possible to increase the efficiency of the propeller-engine unit.

41. Number of floors in gondola. Only two floors in the largest gondola.

Great height helps to make space for the overhead bunks

and heating tubes.

42. Propeller diameter.

43 and 44. Length and floor area of gondolas.

45. Floor area per passenger. This will be extremely large for the smallest dirigible, but will fall to about 2 square meters for the largest. If overhead bunks are used, this is entirely adequate to provide each passenger with a spacious berth and plenty of floor space for chairs, tables, and free passage.

46. Wire thickness, in millimeters. 10 wires will run upward and 10 downward to the right and left of each pulley; in all there will be 20 wires. The six systems will account for 120 fairly thick wires. The cables may be lighter. Near the bases the thick wires may branch out into thinner and more numerous wires.

47. Tension in cables, in kilograms. This tension will be reduced by half when there are 20 pulley blocks in each tensioning system. The range is from 20 to 2,500 kg. The cables are wound on drums to provide tensioning by means of an auxiliary motor. In small dirigibles not much tension will be required; the figure will be only 160 kg even in the case of a dirigible carrying 39 persons. However, the design of large dirigibles might involve changes.

48. Depth of longitudinal girders, in centimeters. When the dirigible envelope is inflated, all the longitudinal members of the dirigible undergo flexure. Cracking and deformation will not occur if adequate tube stiffness, longitudinal corrugations, etc., are provided.

In practice, this depth could be much greater, since appreciable bending will occur only on the one occasion that the dirigible is filled with hydrogen, when a certain deformation is permissible. Subsequently, the bending will be quite insignificant. For the first practicable dirigible the diameter of the tubes should be 10 cm.

49*. Cost of dirigible. The bulk of the dirigible's

*See editor's note at the end of the book.

mass will consist of the simple metal envelope and gondola. This mass should not exceed 70 % of the lift force (cf. column 9); 1 kg of mass-produced iron should cost hardly a kopeck.

70 % of the lift force, in the case of a dirigible 300 meters in length, will mean about 220,000 kg or 2,200 rubles. There remain the motors and the hydrogen, but these will not be as expensive as they are now, after production techniques have undergone enormous improvement. This means that the cost of dirigibles may fall to one-tenth the figures cited as the state of the art advances. On the other hand, however, for the first attempts at dirigible construction the costs will probably be 10 times those estimated, particularly in the case of the small dirigibles, with which we shall inevitably have to start.

50 and 51*. The useful work done by the dirigible annually, and the cost of that work. Carrying 100 kg over 1,000 km is taken as the unit of work. Compare the cost (51) of the work done to the cost (49) of the dirigible. The reader will readily see that the latter is negligible for a dirigible 10 meters tall, but becomes 2-1/2 times greater than the cost of the dirigible for the next craft listed. Subsequently, it becomes 4, 5, 6, 7, and 8 times greater.

*See editor's note at the end of the book.

EDITORS' NOTES ON THE WRITINGS OF

K. E. TSIOLKOVSKIY

CONCERNING DIRIGIBLES

I. THEORY OF THE AEROSTAT

The bulk of this work is contained in an unpublished manuscript written in 1886 (and preserved in the author's personal archives). The gradual publication of this manuscript over a period of years was accompanied by revisions, replanning and re-ordering of the material, and partial changes in the text. A portion of the manuscript, bearing the general title "Theory of the Aerostat," was included in the book "The Metal Dirigible," published in 1892 (first edition) and 1893 (second edition); another portion was published in the article "Independent Horizontal Motion of a Dirigible" in the journal Vestnik opytnoy fiziki i elementarnoy matematiki [Bulletin of Experimental Physics and Elementary Mathematics], Nos. 258-259 (1898), Odessa, but the largest portion of the entire manuscript was published in the journal Vozdukhoplavatel' [Aeronaut] during the years 1905 to 1908, under the heading "The Aerostat and the Airplane." The chapter in the manuscript relating to the horizontal motion of a dirigible was re-edited by the author in 1912 and given the title "Motion of a Dirigible" [Dvizheniye aeronata]. In this last version it is now reprinted here as Chapter XIV, "Motion of an Airship." A portion of the article dealing with the heating of the envelope gas was prepared for the press as the concluding chapter in the series "The Aerostat and the Airplane." In the present edition, it is included in the "Theory of the Aerostat" section as the concluding chapter (XV) of this far-ranging work (cf. notes on Chapter XV).

The text of Chapters I to XIII, "Theory of the Aerostat," was taken from the book "Selected Works of K. E. Tsiolkovskiy,"

[Izbrannyye trudy K. E. Tsiolkovskogo], prepared for the press in 1932-1934, edited by Ya. A. Rapoport under the direct supervision of the author (ONTI [Scientific-Technical Press], Gosmashmetizdat [State Machinery and Metallurgy Press] 1934). The editors' notes on Chapters II-XI in that edition have not lost their appropriateness and are reproduced below in almost complete form.

II. VARIATION IN AEROSTAT VOLUME

Section 56. In accordance with the international standard atmosphere, this gradient is 6.5°C per 1,000 meters.

IV. CERTAIN CONDITIONS WHICH MUST BE SATISFIED BY ANY DIRIGIBLE

Section 118a. Today the bows of airships do not taper to a point, but are rounded (slightly blunted, thickened) in accordance with the requirements of aerodynamics. Cf. section 350.

V. BRIEF DESCRIPTION OF A METAL AIRSHIP

Sections 125, 126. Subsequently, as will be clear from the material that follows, the author arrived at a slightly different solution of these problems.

Section 135. Subsequently, the author gave up displacing the gondola longitudinally, and proposed nonuniform tensioning of the envelope as a means of controlling the static moment. K. E. [Tsiolkovskiy] also suggested placing the control surfaces in the propeller wake.

VI. THE SHAPE OF A DIRIGIBLE

Section 138. This type of internal suspension suggested by Tsiolkovskiy has now won widespread favor among designers of non-rigid and semi-rigid dirigibles, but without Tsiolkovskiy's receiving due credit and acknowledgement.

Sections 144-147. Description of an experimental investigation of airship cross sections, published earlier in Tsiolkovskiy's book "The Metal Dirigible," 2nd Ed., Kaluga, 1893.

Section 171. The same integration may be carried out in the usual manner.

VII. THE CORRUGATED METAL SKIN OF THE AEROSTAT STRETCHING AND BENDING OF THE SURFACE

Section 277. The same formula may be derived by utilizing the concept of the section modulus

$$w = \frac{b \cdot \delta^2}{6} .$$

Section 298. Formulas (299) and (300) are approximate.

Sections 301-304. Here the very cautious assumption is made that the elastic limit K of the material is simultaneously the stability limit of the corrugated envelope in bending.

IX. PRESSURE OF GAS ON CROSS SECTION OF AEROSTAT.
CENTER OF PRESSURE

Section 455. Above, y was used to denote not the radius, but the ordinate of the cross section.

X. A SURVEY OF THE PRINCIPAL FORCES ACTING ON THE
ENVELOPE OF THE AEROSTAT; THEIR RELATIONSHIPS

Section 501. Here, in equations (181) and (182), in place of y_{\max} and y_{\min} we introduce the expressions $y_{\max} = h + y_3$ and $y_{\min} = y_3$.

XI. MODIFICATIONS OF THE COMPONENTS OF
A METAL AIRSHIP

Section 541. This problem was solved by the author elsewhere, in his "A Proposed 40-Man Metal Dirigible," which appeared in print in 1930.

XIV. MOTION OF AN AIRSHIP

Here, and occasionally in other works, the author uses the term "aeronat" or "air boat" for a controllable airship or dirigible.

Our current knowledge of the motion of an airship is rather broader (it should be noted that the content of the chapter "Motion of a Dirigible" corresponds to the text of the corresponding chapter in the 1886 manuscript, "Theory of the Aerostat," and was corrected by the author in 1912). However, the theory postulated here is of great value even now; we need only introduce certain improvements in line with the data of modern theoretical and experimental aerodynamics (for example, in the investigation of flight velocities).

The first part of Chapter XIV in "The Aerostat and the Airplane" (in the journal Vozdukhoplavatel', No. 8, 17 (1908)), entitled "Air Resistance," was devoted to a study of the airplane wing. Vol. I of this edition does not contain that article.

The article "Motion of a Dirigible" is printed first, and the numbering of the equations, as in the case of Chapter XV, begins with No. 1. The author did not submit this article for publication, since it required checking.

For the convenience of the reader, the notation for the variables has been brought into agreement with that of the earlier chapters.

XV. HEATING OF LIGHT GAS AND AN ADJUSTMENT OF LIFT

As subsequently established by Eng. B. N. Vorob'yev, who was entrusted with the study of the manuscripts of K. E. Tsiolkovskiy, Konstantin Eduardovich [Tsiolkovskiy] made a note in 1932 on this manuscript to the effect that it was not to be printed, since he had not corrected it, even though it was of importance.

The contents of this chapter were first published after the author's death, in "Compendium of Scientific and Engineering Works on Dirigible Construction and Aerial Navigation" (No. 6, 1938).

The same compendium includes an article by B. N. Vorob'yev, "On the Article by K. E. Tsiolkovskiy entitled 'Heating of a Light Gas,' in which the author offered the following information based on his own research.

"The article by K. E. Tsiolkovskiy entitled 'Heating of a Light Gas and the Resulting Change in the Lift Force of an Aerostat,' was written in 1908 and reviewed by the author shortly before his death. It appears now for the first time in print. This article originally constituted Chapter XVI of the first portion of one of his most outstanding articles, "The Aerostat and the Airplane," which appeared in print in the periodical "Vozdukhoplavatel'" in the years 1905 to 1908. In this long article Tsiolkovskiy apparently had the intention of expounding his basic positions on the design of both the dirigible (primarily a system he himself devised) and the airplane. However, he was not successful in getting even the first portion of his work, the part devoted to the dirigible, completely into print in that periodical. By the end of 1908, when separate articles covering over two thirds of the first portion had been printed in the journal, the board of directors of the newly

founded All-Russian Aero-Club signed a contract with the editors of Vozdukhoplavatel' under the terms of which the periodical was obliged to print the proceedings of meetings of the Aero-Club, and other materials of that organization, in return for a certain fee. K. E. Tsiolkovskiy was duly informed that lack of space prevented the editors from continuing publication of his article "The Aerostat and the Airplane."

In the same article, B. N. Vorob'yev writes: "K. E. Tsiolkovskiy attributed great significance precisely to Chapter XVI of his work "The Aerostat and the Airplane," referring to it as the thermal calculations for his dirigible. In this connection he wrote: "the thermal calculations have been ready in manuscript form for some time and are being submitted for publication by Vozdukhoplavatel' as a continuation of my major contribution "The Aerostat and the Airplane." But the journal became the organ of the Aero-Club, so that the publication of my articles ceased" (K. E. Tsiolkovskiy. History of My Dirigible. Publ. by ASSNAT, p. 13, 1924)."

In connection with the remark by K. E. Tsiolkovskiy in his earlier work "A Simple Study of the Airship and its Construction" (section 308, No. 2, 1904) to the effect that the "method of heating the gas in the interior of the aerostat was suggested comparatively recently by Partridge," B. N. Vorob'yev asserts in this same article: "Only in 1908 was this important question investigated thoroughly for the first time -- by none other than K. E. Tsiolkovskiy, who carried out several such experiments. Neither prior to him, nor after him, neither in our own nor in the foreign literature, has there been such a consistent analysis of the interesting and serious problem of the artificial heating of the gas."

This assertion of B. N. Vorob'yev's must be accepted as fully justified. Priority in the scientific investigation of the problem of heating the lifting gas in a dirigible certainly belongs to K. E. Tsiolkovskiy.

Since the system of numbering the sections was not maintained in the final chapters, because of the impossibility of publishing the entire contents of "The Aerostat and the Airplane," at that time (1905-1908), we decided to change the section numbers 841-878 in Chapter XV, replacing them by 1-40, respectively, particularly since sections 858 and 859 turned out to be accidentally duplicated in the manuscript.

Section 1. Here, as well as elsewhere in Chapter XV, the author denotes the volume of gas in the envelope by V ; but in Chapter XIV the same volume is denoted by W . We have designated the volume U in accordance with the usage of Chapters I-VIII.

Section 29. Cf. formula (27) in Chapter XIV.
 One quarter of the total (Archimedean) lift force is

$$\frac{1}{4} U \gamma_a ;$$

the total weight of all the passengers is

$$u(\gamma_a - \gamma_g) k_b ;$$

the ratio of these variables is

$$\frac{1}{4} \cdot \frac{1}{k_b} \cdot \frac{\gamma_a}{\gamma_a - \gamma_g} = \frac{1}{4K_b \left(1 - \frac{\gamma_g}{\gamma_a}\right)}$$

Section 36. This holds good for all diatomic gases, e.g., hydrogen, nitrogen, etc. The specific heat of helium, a monatomic gas, is slightly lower.

2. ELEMENTARY DESIGN FOR A METAL DIRIGIBLE

This is a 1914 article. In it, Tsiolkovskiy develops (and to a certain extent repeats) thoughts expounded in earlier writings.

Note on the description of Fig. 14. The author takes a firm stand "against the use of fixed stabilizers." Modern theory on the stability of airships in flight demonstrates the expediency of utilizing such stabilizers independently of the presence of movable control surfaces.

Figure 16, blank in a 1914 brochure and distorted in the 1934 "Selected Works," has been replaced by another plate.

3. THE DESIGN OF A METAL DIRIGIBLE TO CARRY FORTY PASSENGERS

A 1930 article. The present edition reproduces the entire text of this 1930 article, but with some rearrangement. The article was reprinted in its present form in the compendium "Selected Works of K. E. Tsiolkovskiy," 1934, from which the text for the present edition was taken.

In Chapter III, "Notes on the Use of Table," the author's misprints are corrected: 8844 m^3 instead of 8944 , and $17,688$ instead of $17,888$ (p. 17), 9751 and $19,502$ instead of 9857 and $19,714$ (p. 23); the author's corrections are introduced: $12 + 2 + 9 + 3 + 45 + 6 = 77$, and 5472 becomes 5544 (p. 32).

A misprint in the author's edition is corrected in the same table: 1746 instead of 1741 (p. 23), and some minor corrections are made: 193 instead of 201 and -16 instead of -12 (p. 36); -20 instead of -13 (p. 37).

At the end of Chapter V: "Sequence of Practical Operations" section 21, which was omitted by the editor in the 1934 edition, is restored.

4. COMPENDIUM OF THE CORRUGATED STEEL DIRIGIBLE

The 1931 article, with drawings and descriptions reproduced almost in their entirety; accordingly, only the drawings omitted in the previous two articles are included in the current edition.

The table gives a description of a number of geometrically similar dirigibles; the envelope thickness varies from one dirigible to another in proportion to the linear dimensions.

This table is a partial repetition of the contents of "Table of Corrugated-Iron Dirigibles" published in 1915, and compiled for dirigibles ranging from 10 to 300 meters in diameter and 60 to 1800 meters in length with volumes of up to 58 million cubic meters.

Modern high-strength materials render much lighter hulls possible.

Section 17. In contrast to "aeronat" (air boat or lighter-than-air craft), the author uses the term "aeronef" for airplanes (cf. section 17, "Notes on Use of Table.").

Sections 49-51. Naturally, the author's discussion of operating costs and the costs of materials is only of historical interest.

5. Note

In the selection and arrangement of material from the previously published works of K. E. Tsiolkovskiy the editors of this volume have striven to avoid repetition wherever possible. At the same time, the present volume includes all the hitherto unpublished early investigations and reflections which Tsiolkovskiy felt were important in connection with dirigibles.

The editors realize that a similar compendium (albeit a less complete one) was prepared and published during the author's lifetime (ONTI, Gosmashmetizdat, Moscow, 1934). All the material in this compendium is included in the present edition.

A LIST OF THE WORKS OF K. E. TSIOLKOVSKIY
ON DIRIGIBLES AND THE THEORY OF AERONAUTICS

1886

1. Teoriya aerostata. Teoriya i opyt aerostata, imeyushchego v gorizontaI'nom napravlenii udlinennuyu formu (Theory and Practice for an Aerostat With an Elongated Elevation).

Manuscript.

1890

2. O vozmozhnosti postroyeniya metallicheskogo aerostata (On the Possibility of Constructing a Metal Aerostat).

Manuscript.

1892

3. Aerostat metallicheskiy, upravlyayemyy (The Metal Dirigible).

1st Ed., publ. by Chertkov, Moscow.

1893

4. Aerostat metallicheskiy, upravlyayemyy.

2nd Ed., publ. by the author, Kaluga.

5. Vozmozhen li metallicheskiy aerostat (Is the Metal Aerostat Feasible).

Nauka i zhizhn' (Science and Life), No. 51-52, Moscow.

1896

6. Zheleznyy upravlyayemyy aerostat na 200 chelovek (A 200-Man Maneuverable Iron Aerostat).

Publ. by the author, Kaluga.

1897

7. Samostoyatel'noye gorizontal'noye dvizheniye upravlyayemogo aerostata (Independent Horizontal Motion of a Maneuverable Aerostat).

Vestnik opytной fiziki (Herald of Experimental Physics), No. 258-259, Odessa.
Separate brochure, Moscow, 1898.

1898

8. Prostoye izucheniye o vozdushnom korable i yego postroyenii (A Simple Study of the Airship and Its Construction).

Publ. by "Obshchedostupnaya tekhnika" (Popular Engineering), Moscow.

1900

9. Voprosy vozdukhoplavaniya (Problems of Aeronautics).

Publ. by "Nauchnoye obozreniye" (Science Review), No. 10, St. Petersburg. Separate Publication, 1901.

10. Uspekhi vozdukhoplavaniya v XIX v. (Advances in Aeronautics During the 19th Century).

Publ. by "Nauchnoye obozreniye," No. 12, St. Petersburg. Separate publication, 1901.

1904

11. Prostoye ucheniye o vozdushnom korable i yego postroyenii.

2nd Ed., supplemented. Publ. by the author, Kaluga.

1905

12. Metallicheskiy vozdushnyy korabl' (The Metal Airship).

"Znaniye i iskusstvo" (Knowledge and the Arts),

No. 9, St. Petersburg.

1905-1908

13. Aerostat i aeroplan (The Aerostat and the Airplane).

"Vozdukhoplavatel'" (Aeronaut), 1905-1908. Chapter XVI of this work, which the author wrote in 1908 and entitled "Heating of a Light Gas and the Resulting Change in the Lift Force of an Aerostat," remained in MS form until 1938 when it was first published in "Nauchno-tehnicheskiy sbornik rabot po dirizhablestroyeniyu" (Scientific and Technical Collection of Works on Dirigible Construction), No. 6, 1938, publ. by "Aviatsionnaya gazeta" (Aviation Gazette).

1910

14. Metallicheskiy meshok, izmenyayushchiy ob'yem i formu (A Metal Envelope of Variable Volume and Shape).

"Vsemirnoye tekhnicheskoye obozreniye"

(World Technical Review), No. 3,

St. Petersburg.

Separate publication by the author, Kaluga.

15. Metallicheskiy aerostat. Yego vygody i preimushchestva (The Metal Aerostat. Its Merits and Advantages).

"Vozdukhoplavatel'", No. 11, St. Petersburg.

"Aero," St. Petersburg.

1911

16. Zashchita aeronata (Protection of the Dirigible).

Publ. by the author, Kaluga.

1913

17. Pervaya model' chistometallicheskiego aeronata iz volnistogo zheleza (First Model of an All-Metal Dirigible Made of Corrugated Iron).

Publ. by the author, Kaluga.

1914

18. Prosteyshiy proyekt metallicheskiego aeronata (A Simple Plan for a Metal Dirigible).

Publ. by the author, Kaluga.

1915

19. Tablitsa dirizhabley iz volnistogo zheleza (Table of Corrugated-Iron Dirigibles).

Publ. by the author, Kaluga.

20. Dopolnitel'nyye tekhnicheskiye dannyye k postroyeniyu metallicheskoy obolochki (Additional Technical Data on the Construction of a Metal Envelope).

Publ. by the author, Kaluga.

21. Otzyv Ledentsovskogo obshchestva o moyem dirizhable (The Attitude of the Ledentsovskiy Society toward My Dirigible).

Publ. by the author, Kaluga.

1918

22. Vozdushnyy transport (Air Transport).

Publ. by the author, Kaluga.

23. Gondola metallicheskogo dirizhablya i organy yego upravleniya (The Gondola of the Metal Dirigible and Its Controls).

Publ. by the author, Kaluga.

1924

24. Istoriya moyego dirizhablya (History of My Dirigible).
"Izvestiya assotsiatsii naturalistov" (Bulletin of the Association of Naturalists).

Supplement to No. 3, Moscow.

25. Chetyre sposoba nosit'sya nad sushey i vodoy (Four Methods of Traveling Over Land and Sea).

"Vozdukhoplavaniye" (Aeronautics), No. 6-7.

1925

26. Poryadok prakticheskikh rabot pri postroyke metallicheskogo dirizhablya (Sequence of Operations in Building a Metal Dirigible).

"Vozdukhoplavaniye," No. 4-5.

27. Dirizhabl' iz volnistoy stali (A Corrugated-Steel Dirigible).

"Tekhnika i zhizn'" (Engineering and Life), No. 29.

28. Istoriya moyego dirizhablya.

"Ogonyok," No. 14.

1928

29. Novoye o moyem dirizhable i posledniye o nem otzvyvy (New Information and Recent Views on My Dirigible).

Publ. by the author, Kaluga.

30. Dirizhabl' iz volnistoy stali.

Publ. by the author, Kaluga.

1930

31. Stal'noy dirizhabl' (The Steel Dirigible).
"Aviatsiya i khimiya" (Aviation and Chemistry), No. 4.
32. Proyekt metallicheskogo dirizhablya na 40 chelovek
(A Proposed 40-Man Metal Dirigible).
Publ. by the author, Kaluga.
33. Epokha dirizhablestroyeniya (The Era of Dirigible
Building).

MS

1931

34. Dirizhabli (Dirigibles).
Publ. by the author, Kaluga.
35. Atlas dirizhablya iz volnistoy stali (Atlas of a
Corrugated-Steel Dirigible).
Publ. by the author, Kaluga.
36. Metallicheskiy dirizhabl' s izmenyayushchimsya ob'-
yemom (A Variable-Volume Metal Dirigible).
"Nauka i tekhnika," No. 61-62.
37. Kakim dolzhen byt' dirizhabl' (What A Dirigible Should
Be Like).
"Rabocheye izobretatel'stvo"
(Workers' Inventions), No. 1.
38. Dirizhabl' -- osnova vozdušnogo transporta (The Dirigible
as the Basis of Air Transport).
"Rabocheye izobretatel'stvo," No. 5.

39. Gazy dlya dirizhabley (Gases for Dirigibles).

"Rabocheye izobretatel'stvo," No. 17.

40. Gazovyye vozdushnyye //korabli ili aeronaty (Gas-Filled Airships or Dirigibles).

"Vestnik inzhenerov i tekhnikov"

(Herald of Engineers and Technicians), No. 5.

1932

41. Novyy tip dirizhablya (A New Type of Dirigible).

"V boy za tekhniku"

(The Militant Engineer).

No. 17-18.

42. Znachenkiye velichiny dirizhablya (The Significance of the Size of Dirigibles).

"Vestnik inzhenerov i tekhnikov," No. 3.

43. Nekotoryye poyasneniya k osobennostyam konstruksii tsel'nometallicheskogo dirizhablya (Some Notes on the Design of an All-Metal Dirigible).

"Vestnik inzhenerov i tekhnikov," No. 4.

44. Moy dirizhabl' i stratoplan (My Dirigible and Stratoplane).

"Izvestiya VTsIK" (Bulletin of the

All-Union Central Executive Committee), 288.

45. Dirizhabl' i raketa protiv katastrof (The Emergency Use of Dirigibles and Rockets).

MS

1933

46. Dirizhabl', stratoplan i zvezdolet kak tri stupeni

velichayshikh dostizheniy SSSR (The Dirigible, the Strato-
plane and the Astroplane as Three Stages in the Magnifi-
cent Achievements of the USSR).

"Grazhdanskaya aviatsiya" (Civil
Aviation), No. 9.

47. Programma rabot po stal'nomu dirizhablyu (A Program of
Work on the Steel Dirigible).

Tekhnicheskiy byulleten' Dirizhablestroya
(Technical Bulletin of Dirigible Construction),
No. 4.

1934

48. Dostizheniye vysot stratostatom (High-Altitude Flights
by Stratostat).

"Grazhdanskaya aviatsiya," No. 9.

49. Izbrannyye trudy K. E. Tsiolkovskogo (Selected Works of
K. E. Tsiolkovskiy).

Book 1. "Tsel'nometallicheskiy dirizhabl'"
(The All-Metal Dirigible).

Book 2. "Reaktivnyye dvizheniye"
(Reaction Propulsion)

1935

50. Pobeda geroicheskikh lyudey (The Victory of Heroic People).

"Nauka i zhizn'," No. 8 (10).

Tsiolkovskiy's last manuscripts published posthumously:

51. Poyezd dirizhabley (A Dirigible Train).

"Na strazhe" (Sentinel), 20 Sep 1936.

Coll.: "K. Tsiolkovskiy," Publ. by

Aeroflot, 1939.

52. Aviatsiya, vozdukhoplavaniye i raketoplavaniye v XX veke
(Aviation, Aeronautics and Rocket Flight in the
20th Century).

Same collection, 1939.

53. Dirizhabli (Dirigibles).

Same collection, 1939.

FARADAY TRANSLATIONS
15 PARK ROW
NEW YORK 38, N. Y.

"The aeronautical and space activities of the United States shall be conducted so as to contribute . . . to the expansion of human knowledge of phenomena in the atmosphere and space. The Administration shall provide for the widest practicable and appropriate dissemination of information concerning its activities and the results thereof."

—NATIONAL AERONAUTICS AND SPACE ACT OF 1958

NASA SCIENTIFIC AND TECHNICAL PUBLICATIONS

TECHNICAL REPORTS: Scientific and technical information considered important, complete, and a lasting contribution to existing knowledge.

TECHNICAL NOTES: Information less broad in scope but nevertheless of importance as a contribution to existing knowledge.

TECHNICAL MEMORANDUMS: Information receiving limited distribution because of preliminary data, security classification, or other reasons.

CONTRACTOR REPORTS: Technical information generated in connection with a NASA contract or grant and released under NASA auspices.

TECHNICAL TRANSLATIONS: Information published in a foreign language considered to merit NASA distribution in English.

TECHNICAL REPRINTS: Information derived from NASA activities and initially published in the form of journal articles.

SPECIAL PUBLICATIONS: Information derived from or of value to NASA activities but not necessarily reporting the results of individual NASA-programmed scientific efforts. Publications include conference proceedings, monographs, data compilations, handbooks, sourcebooks, and special bibliographies.

Details on the availability of these publications may be obtained from:

SCIENTIFIC AND TECHNICAL INFORMATION DIVISION
NATIONAL AERONAUTICS AND SPACE ADMINISTRATION
Washington, D.C. 20546