

AD _____

Award Number: DAMD17-00-1-0125

TITLE: Regulation of I Transport in Breast Cancer Cell Lines

PRINCIPAL INVESTIGATOR: Ms. Claudia Riedel
Nancy Carrasco, M.D.

CONTRACTING ORGANIZATION: Albert Einstein College of Medicine
Bronx, New York 10461

REPORT DATE: June 2001

TYPE OF REPORT: Annual Summary

PREPARED FOR: U.S. Army Medical Research and Materiel Command
Fort Detrick, Maryland 21702-5012

DISTRIBUTION STATEMENT: Approved for Public Release;
Distribution Unlimited

The views, opinions and/or findings contained in this report are those of the author(s) and should not be construed as an official Department of the Army position, policy or decision unless so designated by other documentation.

20020416 113

REPORT DOCUMENTATION PAGEForm Approved
OMB No. 074-0188

Public reporting burden for this collection of information is estimated to average 1 hour per response, including the time for reviewing instructions, searching existing data sources, gathering and maintaining the data needed, and completing and reviewing this collection of information. Send comments regarding this burden estimate or any other aspect of this collection of information, including suggestions for reducing this burden to Washington Headquarters Services, Directorate for Information Operations and Reports, 1215 Jefferson Davis Highway, Suite 1204, Arlington, VA 22202-4302, and to the Office of Management and Budget, Paperwork Reduction Project (0704-0188), Washington, DC 20503

1. AGENCY USE ONLY (Leave blank)		2. REPORT DATE June 2001	3. REPORT TYPE AND DATES COVERED Annual Summary (1 Jun 00 - 30 May 01)	
4. TITLE AND SUBTITLE Regulation of I Transport in Breast Cancer Cell Lines			5. FUNDING NUMBERS DAMD17-00-1-0125	
6. AUTHOR(S) Ms. Claudia Riedel Nancy Carrasco, M.D.				
7. PERFORMING ORGANIZATION NAME(S) AND ADDRESS(ES) Albert Einstein College of Medicine Bronx, New York 10461 E-Mail: riedel@aecom.yu.edu			8. PERFORMING ORGANIZATION REPORT NUMBER	
9. SPONSORING / MONITORING AGENCY NAME(S) AND ADDRESS(ES) U.S. Army Medical Research and Materiel Command Fort Detrick, Maryland 21702-5012			10. SPONSORING / MONITORING AGENCY REPORT NUMBER	
11. SUPPLEMENTARY NOTES Report contains color				
12a. DISTRIBUTION / AVAILABILITY STATEMENT Approved for Public Release; Distribution Unlimited			12b. DISTRIBUTION CODE	
13. ABSTRACT (Maximum 200 Words) Like thyroid tissue, breast tissue and some breast cancers are able to accumulate iodide. Iodide accumulated by the lactating breast is secreted into the milk. Iodide is then used by the nursing newborn for the biosynthesis of thyroid hormones, which are essential for the newborn's development. The capacity to accumulate iodide has been used successfully for over 50 years in the treatment of thyroid cancer by administration of radioiodide to patients. It is possible that iodide accumulation may also be used as a potential aid for diagnosis and treatment of breast cancer. The Na ⁺ /I ⁻ symporter (NIS) mediates active iodide accumulation in breast and thyroid. Based on my preliminary studies in thyroid NIS, we are currently studying the regulatory mechanisms of NIS in breast cell lines. We are studying NIS regulation at both the transcriptional and post-transcriptional levels, including the role of phosphorylation in the regulation of NIS activity and its targeting to the cell surface in breast cell lines.				
14. SUBJECT TERMS Cancer, breast cells, hormonal regulation, iodide transport, phosphorylation, transcriptional regulation			15. NUMBER OF PAGES 36	
			16. PRICE CODE	
17. SECURITY CLASSIFICATION OF REPORT Unclassified	18. SECURITY CLASSIFICATION OF THIS PAGE Unclassified	19. SECURITY CLASSIFICATION OF ABSTRACT Unclassified	20. LIMITATION OF ABSTRACT Unlimited	

Table of Contents

Cover.....1

SF 298.....2

Table of Contents.....4

Introduction.....5

Body.....7

Key Research Accomplishments.....10

Reportable Outcomes.....11

Conclusions.....12

References.....15

Figure Legends.....16

Figures.....20

Appendix 1.....24

Appendix 2.....26

Introduction

Breast cancer remains the leading cause of cancer death in women ages 15-54. It was estimated that in 2001 about 192,200 women would be diagnosed with breast cancer in the U.S and nearly 40,800 would die from the disease (1). Unquestionably, current available therapies for breast cancer, including surgery, chemotherapy, and radiotherapy, are not satisfactory. Therefore, improvement of detection and treatment requires exploration of alternative diagnostic and therapeutic strategies. The lactating mammary gland is one of very few tissues which, like the thyroid, has the ability to actively accumulate iodide (I^-) (2). In the thyroid, this ability is used as a centerpiece to diagnose and often treat thyroid ailments, including thyroid cancer. In contrast, I^- transport by mammary tissue has yet to be thoroughly examined for its potential as a diagnostic and therapeutic tool in breast cancer.

Thyroidal I^- transport has been an area of intense research (3 [appendix 2]; 4). Yet it was not until 1996 that, after a decades-long search by numerous groups, our laboratory isolated the cDNA that encodes the rat thyroid Na^+/I^- symporter (NIS), a 618 amino acid plasma membrane glycoprotein that mediates active I^- uptake in the thyroid (5). We have subsequently generated high-affinity anti-NIS antibodies (Abs) (6). Significantly, using our anti-NIS Abs we have demonstrated extrathyroidal NIS expression in mammary gland (mgNIS) during lactation, and have shown that mgNIS catalyzes I^- transport in mammary tissue (7). It is clear that thyroid NIS and mgNIS respond to distinct regulatory mechanisms. Physiologically, I^- transport in the mammary gland occurs in late pregnancy and during the course of lactation. *In vivo* studies have shown that NIS expression is regulated in a reversible manner by suckling during lactation (7). Studies in

ovariectomized mice showed that the combination of β -estradiol, oxytocin and prolactin in the absence of progesterone (i.e. the relative hormonal levels prevalent in mice during lactation) leads to the highest level of NIS expression (7). An adequate supply of I^- for sufficient thyroid hormone production is essential for proper development of the newborn's nervous system, skeletal muscle and lungs. Moreover, we have also shown that healthy lactating mammary tissue is not the only breast tissue expressing mgNIS. Human breast carcinomas and experimental mammary carcinomas in transgenic mice bearing constitutively activated oncogenes (*neu*, *ras* or polyoma T antigen) also express mgNIS (7). These observations suggest that mgNIS expression can be regulated by transcription factors that are activated by the *neu*, *ras* or polyoma T antigen signal pathways. Therefore, it would be highly informative to study and compare the mechanisms by which mgNIS is expressed during lactation and in breast cancer. It is our hypothesis that regulatory factors that lead to expression and activation of mgNIS in lactating mammary tissue are also operational in some breast cancers. Our purpose is to identify the regulatory mechanisms of NIS expression in mammary cells at the transcriptional and post-transcriptional levels. At the transcriptional level we are studying the sequences within the NIS promoter and the transcription factors required for NIS gene transcription. At the post-transcriptional level we are examining the role of phosphorylation in the targeting of mgNIS to the plasma membrane and/or in mgNIS activity.

Body

1) Regulation of mgNIS expression in tumoral and non-tumoral breast cell lines.

Several mammary cell lines were analyzed for NIS expression by several experimental approaches (Table. I). Physiological expression of mgNIS occurs at the end of pregnancy and during lactation (7). We treated cells with different hormones and with charcoal-treated serum for different periods of time. NIS expression was initially identified in two tumoral breast cell lines, AC826 and NAFA cells, by Western Blot (both cell lines were kindly provided by Dr. Pestell, Albert Einstein College of Medicine) (Fig. 1A and 1B). However, after several passages both cell lines lost NIS expression.

NIS expression was tested in HC11, a non-tumoral cell line, by Western blot analysis. A broad band at 95 kDa was observed in HC11 cells that were kept in media with charcoal-treated serum (Fig. 2A, *lane 1*). The treatment of serum with charcoal is broadly used to eliminate molecules such as insulin and steroids from serum. We observed that the addition of prolactin to the culture media increased the level of expression of the 95 kDa polypeptide. The electrophoretic mobility of the band (molecular weight and shape) and its induction after hormonal treatment (charcoal-treated serum and prolactin) led us to think that this protein was NIS. Na⁺-dependent perchlorate inhibitable I⁻ uptake activity was not detected in HC11 regardless of the hormonal treatment (Fig. 2B). To ensure that the 95 kDa band corresponded to NIS, we performed a Western blot incubating only with the second antibody. To our surprise, the same 95 kDa band detected with anti-NIS Ab was detected with the second Ab only in HC11 cells (Fig. 2C), indicating that the second antibody interacted nonspecifically with a protein that has the same electrophoretic mobility as NIS and which is also regulated by hormonal-treatment and charcoal-treated serum. To analyze whether a fraction of the 95 kDa band could correspond to NIS and not only to the

non-specific protein, membrane vesicles from HC11 cells were subjected to Western Blot analysis. In this case, the nitrocellulose was treated with goat-serum to block all non-specific binding before incubation with the first and second antibodies (Fig. 2D). Western blot analysis revealed that the 95 kDa band completely disappeared when the nitrocellulose was treated with goat serum, regardless of whether the first and/or second Ab were used. To assess whether HC11 cells express NIS mRNA, Northern blot experiments were performed. Northern blot analysis revealed that no NIS mRNA was detected in HC11 cells with or without hormonal-treatment. Our positive control was total RNA from FRTL-5 cells (Fig. 2E). In conclusion, these results confirmed that there is no NIS protein expression and that there is no NIS mRNA or that the message is not-abundant in HC11 cells.

The 5'-flanking regions of the NIS gene that activate or repress NIS transcription in FRTL-5 cells have been described (8). Taking advantage of the fact that HC11 cells do not seem to express NIS mRNA (Fig. 2E) in conditions under which other lactogenic markers such as β -casein are expressed, we analyzed whether there are sequences in the NIS DNA 5'-flanking region that repress its transcriptional activity in HC11 cells. We transiently transfected these cells with chimeric constructs of the NIS promoter region (8) fused to the luciferase (LUC) reporter gene (8). These chimeric constructs contain either the entire upstream region or deletion derivatives of the NIS 5'-flanking region (Fig. 3A). Luc activity was assayed in HC11 cells transiently transfected with these chimeric constructs. Analysis of LUC activity revealed that the entire NIS 5'-flanking region was not able to induce the transcription of luciferase (Fig. 3B). This result is consistent with our observation that there was no NIS mRNA expression in HC11 cells. Constructs that contained deletions in the upstream region did not elicit luciferase activity, with the exception of one containing sequences from -564 to +1 (Fig. 3B). Interestingly, addition of upstream sequences to -564 (Fig. 3A) resulted in the inhibition of luciferase activity. These

results suggest that there are factors in HC11 that bind upstream regions of 564 and have a negative effect on NIS transcription.

2) Phosphorylation studies of mgNIS in tumoral NAFA cells.

To evaluate whether mgNIS is phosphorylated, NAFA cells (a cell line derived from mouse mammary tumor cells, which expressed an activated *ras* oncogene) were metabolically labeled with ^{32}P -ortho-phosphoric acid, followed by immunoprecipitation with anti-NIS Ab. The immunoprecipitate was electrophoresed, electrotransferred to nitrocellulose and autoradiographed. The autoradiogram showed that mgNIS was phosphorylated (Fig. 4A). To determine the identity of mgNIS amino acid residues that are phosphorylated, a phosphoamino acid map of NIS from NAFA cells was obtained. NAFA cells were metabolically labeled with ^{32}P -ortho-phosphoric acid, followed by immunoprecipitation with anti-NIS Ab. The immunoprecipitate was electrophoresed, and electrotransferred to nitrocellulose. The NIS band detected by autoradiogram was excised from the nitrocellulose, digested with trypsin and hydrolyzed with 6N HCl as described (Appendix 1). The phosphoamino acid map indicated that mgNIS in NAFA cells is phosphorylated in serine (Ser) and threonine (Thr) residues (Fig. 4B). In contrast, in thyroid cells, NIS is phosphorylated exclusively at Ser residues (Fig. 4B). To analyze the phosphorylation pattern of mgNIS in NAFA cells, a phosphopeptide map of mgNIS was obtained (See appendix 1 under "Experimental Procedures"). Analysis of the autoradiogram resolved seven phosphopeptides (Fig. 4C). Interestingly, two of the phosphopeptides seemed to be common to mgNIS and thyroid NIS (phosphopeptides 10 and 11 from NAFA cells and 4 and 2 from FRTL-5 cells) as calculated by the migration coefficient, whereas the others were not. We are presently studying the mechanism by which NIS phosphorylation occurs in breast cell lines under different hormonal treatments.

Key research accomplishments

- 1. NIS expression was detected in two tumoral breast cell lines, AC826 and NAFA cells. We found that these cells lost NIS expression after five passages.
- 2. Transcription of NIS was inhibited in HC11 cells. We found that the sequence –564 to +1 nucleotide elicited transcription activity in HC11 cells. However, further sequences to -564 inhibited transcriptional activity. These observations suggest that there are factors in HC11 cells that bind sequences upstream to –564 that inhibit NIS transcription.
- 3. mgNIS from NAFA cells was phosphorylated *in vivo* at Ser and Thr residues. The phosphorylation pattern of mgNIS was different from thyroid NIS. These results suggest that phosphorylation may be a regulatory mechanism of NIS in breast tissue.

Reportable outcomes

1. **Riedel C, Levy O. and Carrasco N.** (2001) “Post-transcriptional regulation of the Sodium/Iodide symporter by Thyrotropin” *J. Biol. Chem.* Vol 276, 21458-21463. **(Appendix 1)**
2. **Riedel C, Dohán O, De la Vieja A, Ginter CS and Carrasco N.** (2001) “Journey of the iodide transporter NIS: from its molecular identification to its clinical role in cancer”. *Trend Biochem. Sci.* Vol 26, (459-517). **(Appendix 2)**
3. **Riedel C, Ginter CS and Carrasco N** (2002) “Identification of the phosphorylation sites of the sodium/iodide symporter (NIS)” (*in preparation*).

Conclusions

We found NIS expression in AC826 and NAFA cells, two tumoral breast cell lines (Table I and Figs. 1A and 1B). AC826 cells are derived from transgenic mice overexpressing *ras* under an MMTV promoter. NAFA cells are derived from mammary cells of transgenic mice that express an activated *ras* oncogene. No I⁻ transport was detected in these cell lines (data not shown), suggesting that NIS may be recruited to intracellular compartments as was observed in FRTL-5 cells kept in the absence of TSH (Appendix 1). We found that mgNIS was phosphorylated *in vivo* in NAFA cells (Fig. 4A). Analysis of the phosphoamino acid map revealed that Ser and Thr residues were phosphorylated in mgNIS (Fig. 4B). NIS phosphorylation at Thr residues was detected only in NAFA cells, but not in FRTL-5 or COS cells, suggesting that different kinases and/or phosphatases modify the phosphorylation pattern of NIS in mammary cells. The phosphorylation pattern of mgNIS was different from thyroid NIS (Fig. 4C). These results strongly suggest that phosphorylation may play a role as a mechanism for NIS regulation in breast cells. Therefore, current studies are addressing the significance of mgNIS phosphorylation for NIS function and recruitment to the plasma membrane. We also found that AC826 and NAFA cells lost their expression of mgNIS after several passages in culture. We think that several passages alter gene stability in these cells affecting NIS expression. Therefore, we need to work with early passage cells.

HC11 is a mammary cell line originally derived from the mouse mammary epithelial cell line COMMA-1D. HC11 cells are unique in that they produce the major mouse milk protein β -casein under the control of lactogenic hormones. NIS expression was analyzed in this cell by several approaches (Fig. 2). We found that a broad band at 95 kDa was detected when cells were incubated in charcoal-treated serum and its level of expression increased with the addition of

prolactin (Fig. 2A). These observations led us to think that this band was NIS protein. However, this notion was discarded after several experiments (Figs. 2B-2D) and after trying different second antibodies. Northern blot analysis of total RNA from HC11 cells indicated that there is no NIS mRNA or it is not-abundant in these cells (Fig. 2E). Our experiments demonstrate that there was no NIS expression at the mRNA or protein level in HC11 cells. We demonstrated that the 95 kDa band represents a non-specific interaction generated by the second Ab (Figs. 2B and 2C). We found that the NIS promoter sequence -564 to +1 was capable of eliciting transcription in HC11 cells (Fig. 3B). Upstream regions of 564, or the entire upstream sequence, did not elicit transcriptional activity (Fig. 3B). These results are consistent with the lack of NIS expression in HC11 cells. Considering these results together we propose that there are factors in HC11 that bind to sequences upstream to 564 (Fig. 3A) and have an inhibitory effect on NIS transcription in HC11 cells. Current studies directed to identify these factors and their regulatory mechanisms will provide insights into NIS regulation in mammary cells at the molecular level.

The ability of cancerous thyroid cells to actively transport I^- via NIS provides a unique and effective delivery system to detect and target these cells for destruction with therapeutic doses of radioiodide without harming other tissues. Therefore, it seems feasible that radioiodide could be a diagnostic and therapeutic tool for the detection and destruction of other cancers in which NIS is functionally expressed. NIS expression was found in 87 % of human breast carcinomas and NIS functional expression was detected in experimental adenocarcinomas in mice, either carrying an activated *ras* oncogene or overexpressing *neu* oncogene or polyoma T antigen (7). These results suggest that radioiodide could represent a potentially novel alternative for the diagnosis and treatment of breast cancer. The understanding of NIS regulation at the molecular level in tumoral and non-tumoral cell lines will provide useful knowledge for the manipulation of NIS expression

in these cells and it could have an important role in the treatment of breast cancer with radioiodide therapy.

References

1. **Esteva, F.J., V. Valero, L. Pusztai, L. Boehnke-Michaud, A.U. Buzdar, and G.N. Hortobagyi.** (2001). Chemotherapy of metastatic breast cancer: what to expect in 2001 and beyond. *Oncologist* 6:133-146.
2. **Brown-Grant K.** (1961). Extra thyroidal iodide concentrating mechanisms. *Physiol Rev* 41:189-213.
3. **Riedel, C., O. Dohan, A. De la Vieja, C.S. Ginter, and N. Carrasco.** (2001). Journey of the iodide transporter NIS: from its molecular identification to its clinical role in cancer. *Trends Biochem Sci* 26:490-496.
4. **Schmutzler, C.** (1991). Regulation of the sodium/iodide symporter by retinoids - a review. *Exp Clin Endocrinol Diabetes* 109:41-44.
5. **Dai, G., O. Levy, and N. Carrasco.** (1996). Cloning and characterization of the thyroid iodide transporter. *Nature* 379:458-460.
6. **Levy, O., G. Dai, C. Riedel, C.S. Ginter, E.M. Paul, A.N. Lebowitz, and N. Carrasco.** (1997). Characterization of the thyroid Na⁺/I⁻ symporter with an anti-COOH terminus antibody. *Proc Natl Acad Sci U S A* 94:5568-5573.
7. **Tazebay, U.H., I.L. Wapnir, O. Levy, O. Dohan, L.S. Zuckier, Q.H. Zhao, H.F. Deng, P.S. Amenta, S. Fineberg, R.G. Pestell, and N. Carrasco.** (2000). The mammary gland iodide transporter is expressed during lactation and in breast cancer [see comments]. *Nat Med* 6:871-878.
8. **Ohno, M., M. Zannini, O. Levy, N. Carrasco, and R. di Lauro.** (1999). The paired-domain transcription factor Pax8 binds to the upstream enhancer of the rat sodium/iodide symporter gene and participates in both thyroid-specific and cyclic-AMP-dependent transcription. *Mol Cell Biol* 19:2051-2060.

Figure Legends

Table I: Analysis of NIS expression in tumoral breast cell lines. Several tumoral breast cell lines were tested for NIS expression by immunoblot (imm) and I⁻ transport activity (I⁻ uptake). These cell lines were subjected to the indicated treatments. Results are expressed as positive (+), negative (-) and non-tested (/).

Table II: Analysis of NIS expression in non-tumoral breast cell lines. Several breast cell lines were tested for NIS expression by immunoblot (imm) and I⁻ transport activity (I⁻ uptake). These cell lines were subjected to the indicated treatments. Results are expressed as positive (+), negative and (-) non-tested (/).

Figure 1. NIS expression in tumoral breast cell lines. AC826, NAFA and FRTL-5 cells grown to 90% confluence in 100-mm culture plates were harvested, washed and homogenized in sucrose buffer to prepare membrane fractions (appendix 1). **(A)** Immunoblot of membrane fractions from 50 µg of AC826 (*lane 1*) and 30 µg of FRTL-5 (*lane 2*) cells using anti-NIS Ab. **(B)** Immunoblot of membrane fractions from 30 µg of FRTL-5 (*lane 1*), 40 (*lane 2*) and 80 µg (*lane 3*) of NAFA cells using anti-NIS Ab. NIS corresponds to the 85 kDa band. FRTL-5 cells were used as a positive control.

Figure 2. Analysis of NIS expression in HC11 cells. **(A)** HC11 cells grown to confluence in 100-mm tissue culture plates were kept in growth media (*lane 2*); charcoal-treated serum was added alone for 24 (*lane 3*) or 48 hrs (*lane 4*) or charcoal-treated serum was first added alone for

24 hrs and then followed by charcoal-treated serum plus 5 µg/ml prolactin for additional 24 hrs (*lane 5*). Cells were harvested and MV were prepared, electrophoresed, electrotransferred to nitrocellulose and analyzed by immunoblot with anti-NIS Ab. **(B)** I⁻ transport was measured in FRTL-5 cells and HC11 cells grown to confluence in 12-well tissue culture plates. HC11 cells were treated as described in (A). Values represent the means ± SE of four independent experiments performed in triplicate. **(C)** Immunoblot analysis of HC11 cells performed as described in (A) except using only the second anti-rabbit Ab. **(D)** Membrane fractions from hormone-treated HC11 cells were prepared, electrophoresed, electrotransferred to nitrocellulose. The nitrocellulose was blocked with goat serum in milk for 1 hr and the immunoblot was performed as described in (A). Anti-NIS Ab was used as first Ab and anti-rabbit as second Ab (*lanes 1 and 2*). In *lanes 3 and 4* only the second anti-rabbit Ab was used. **(E)** Northern blot analysis of NIS expression in HC11 cells and FRTL-5 cells. HC11 were hormonized-treated as described in (A). Total RNA was extracted, resolved using a 1.2% formaldehyde agarose gel and transferred onto nitrocellulose membranes. Northern blot analysis was performed using biotinylated NIS primer cDNA as a probe for hybridization. Total RNA from FRTL-5 cells was used as positive control (F) and total RNA from Relle II 55-106 rat hepatocyte cell line was used as negative control (Kindly donated by Dr. Czaja Albert Einstein College of Medicine) (L). Growth (G), charcoal-treated serum (C-S), prolactin 24h (P-24), prolactin 72h (P-72).

Figure 3. NIS Promoter activity is negatively regulated in HC11 cells. **(A)** Schematic representation of various chimeric LUC plasmids containing different fragments from the rNIS 5'-flanking region in front of its own promoter. **(B)** HC11 cells were seeded in 12-well tissue culture plates 24 h prior to transfection with lipofectamine plus (Gibco). Each well was

transfected with 0.5 μg of the luciferase reporter containing the NIS promoter construct and 0.13 μg of renilla luciferase plasmid. The renilla luciferase plasmid was used as a control for transfection efficiency. At 24 h after transfection, cells were treated with 0.5 μg prolactin and charcoal-serum. Cells were lysed with 250 μl of lysis solution (Promega) of which 10 μl was used to measure Luciferase activity. The activity of each construct is expressed relative to that of PGL3-basic. Results are the mean of three separate experiments, with each experiment done in duplicate. In all experiments, a Renal Luciferase activity was introduced to normalize for transfection efficiency. Hela cells were used as negative control for NIS promoter activity.

Figure 4. Analysis of mgNIS phosphorylation in NAFA cells. NAFA and FRTL-5 cells were grown to 70% confluence in 100-mm tissue culture plates. Cells were labeled *in vivo* with 100 $\mu\text{Ci/ml}$ ^{32}P for 5 h at 37°C. Cells were lysed, and NIS was immunoprecipitated with anti-NIS Ab, electrophoresed, electrotransferred to nitrocellulose and analyzed by autoradiography. **(A)** Autoradiography of phosphoNIS from NAFA and FRTL-5 cells. **(B)** NIS bands from S551-552A were excised from the nitrocellulose and digested with trypsin. 1/10 of the ^{32}P -labeled tryptic phosphopeptides was hydrolyzed in 6N HCl at 110°C for 1 hour. ^{32}P -Phosphoamino acids were resuspended in a mixture of standard phosphoamino acids (containing phosphoserine [pS], phosphothreonine [pT], phosphotyrosine [pY] and inorganic phosphate [P_i]) and separated by two-dimensional electrophoresis. ^{32}P -phosphoamino acids were visualized by autoradiography and the phosphoamino acid standards were detected after ninhydrin reaction. The position of each phosphoamino acid standard is indicated with a circle in the autoradiogram. **(C)** 9/10 of the tryptic phosphopeptides from NAFA and FRTL-5 cells was separated in two dimensions on

cellulose thin layer plates by electrophoresis (pH 1.9) for 50 min at 650 V, followed by thin layer chromatography. Phosphopeptides were visualized by autoradiography.

Table I:

Cell line	non-treatment		oxytocin		cAMP		prolactin/hydrocortisone		H89		A23187		β -estadiol	
	imm	I-uptake	imm	I-uptake	imm	I-uptake	imm	I-uptake	imm	I-uptake	imm	I-uptake	imm	I-uptake
NEU	-	-	-	-	-	-	-	-	-	-	-	-	-	-
MYC	-	-	-	-	-	-	-	-	-	-	-	-	-	-
AC816	+	-	-	-	-	-	-	-	-	-	-	+	-	-
AC236	-	-	-	-	-	-	-	-	-	-	-	-	-	-
5H1.15.11	-	-	-	-	-	-	-	-	-	-	-	-	-	-
AC711	-	-	-	-	-	-	-	-	-	-	-	-	-	-
MCF-7	-	-	-	-	-	-	-	-	-	-	-	-	-	-
NAFA	+	-	/	/	/	/	/	/	/	/	/	/	/	/

Table II:

Cell line	non-treatment		oxytocin		charcoal-treated serum		prolactin/hydrocortisone		extracellular matrix		β -estradiol	
	imm	I-uptake	imm	I-uptake	imm	I-uptake	imm	I-uptake	imm	I-uptake	imm	I-uptake
COMMA-1D	-	-	-	-	-	-	-	-	-	-	-	-
HC11	-	-	-	-	-	-	-	-	/	/	-	-
CDRN-4	-	-	-	-	-	-	-	-	/	/	-	-
CID-9	-	-	-	-	-	-	-	-	/	/	-	-

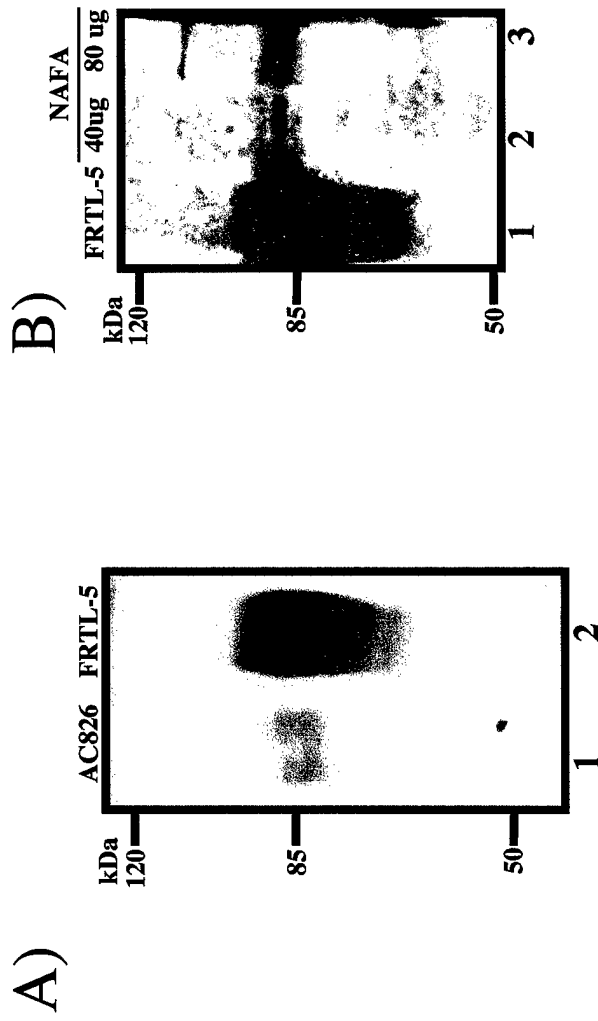

Fig. 1

Fig.2

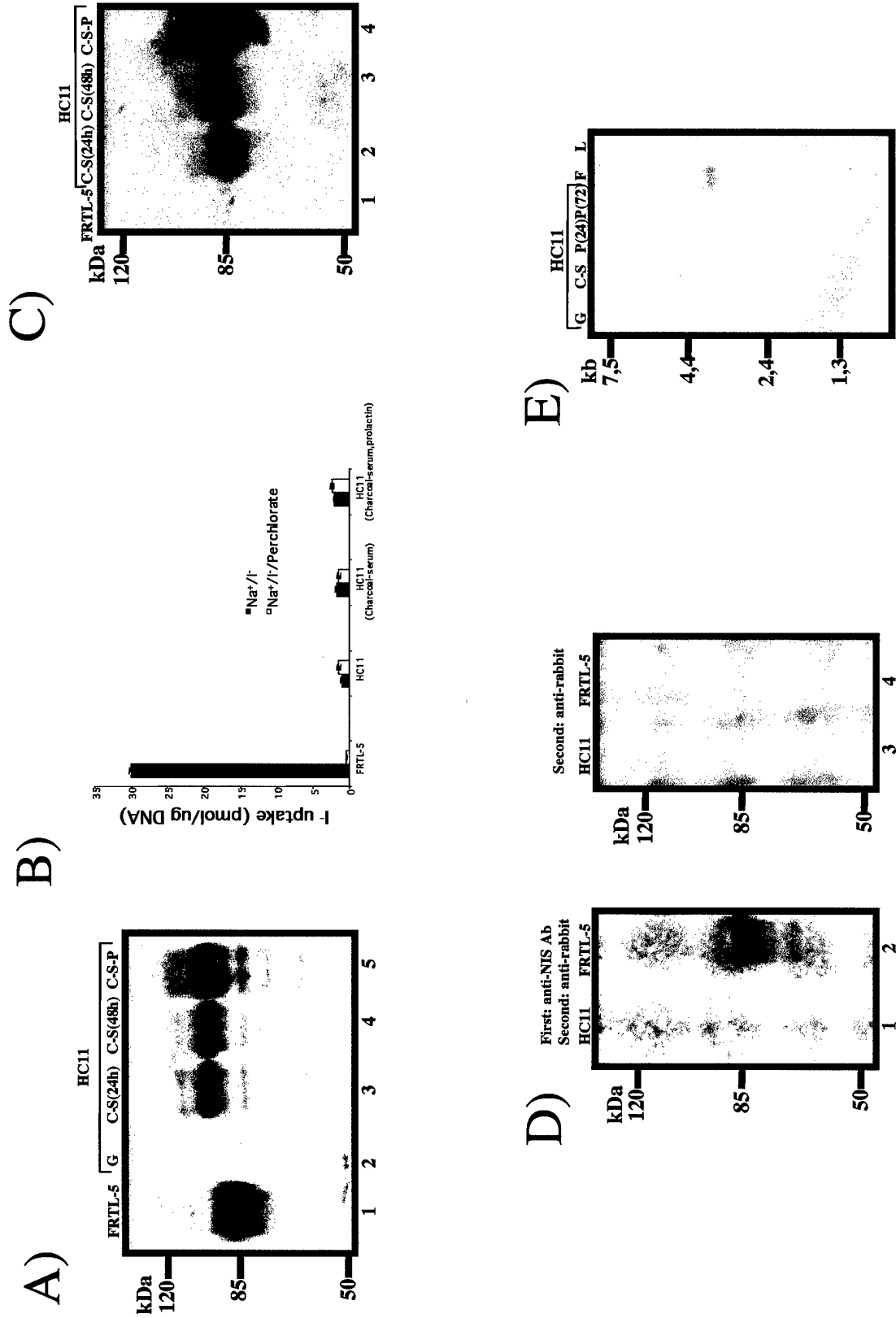

Fig. 3

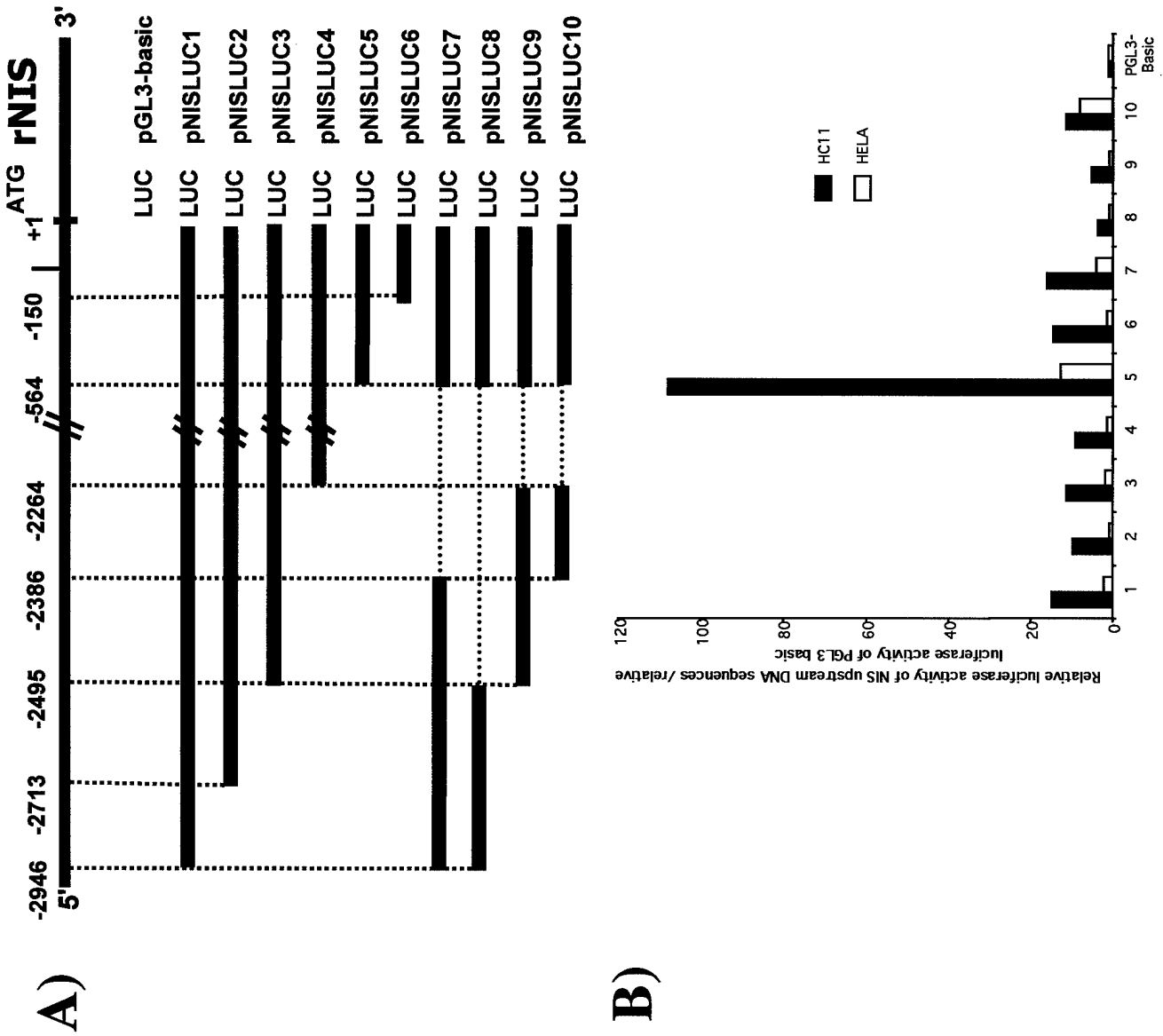
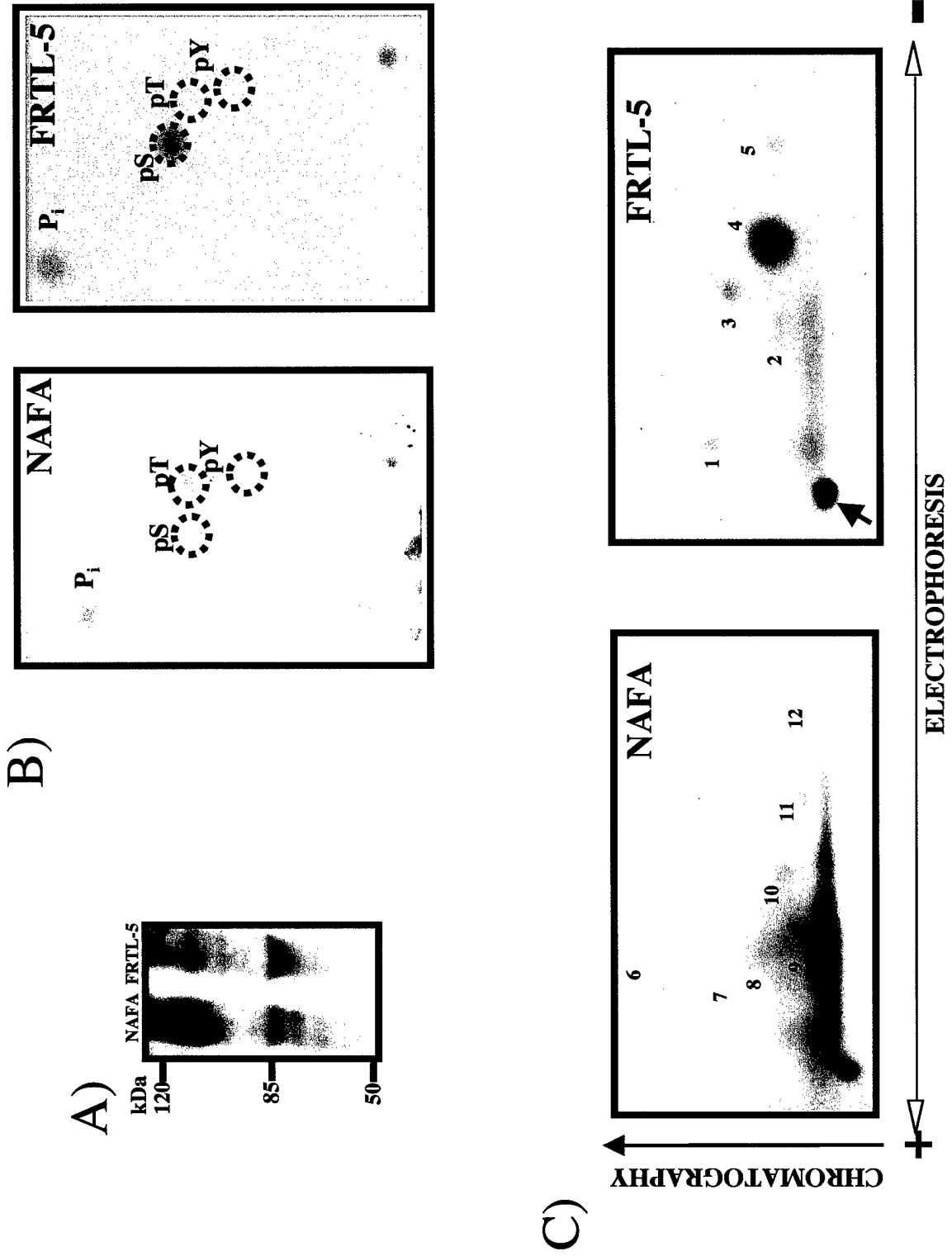

Fig. 4



Post-transcriptional Regulation of the Sodium/Iodide Symporter by Thyrotropin*

Received for publication, January 22, 2001, and in revised form, March 21, 2001
Published, JBC Papers in Press, April 4, 2001, DOI 10.1074/jbc.M100561200

Claudia Riedel[‡]§, Orlie Levy[¶], and Nancy Carrasco[‡]||

From the [‡]Department of Molecular Pharmacology, Albert Einstein College of Medicine, Bronx, New York 10461

The Na⁺/I⁻ symporter (NIS) is a key plasma membrane glycoprotein that mediates active I⁻ transport in the thyroid gland (Dai, G., Levy, O., and Carrasco, N. (1996) *Nature* 379, 458–460), the first step in thyroid hormone biogenesis. Whereas relatively little is known about the mechanisms by which thyrotropin (TSH), the main hormonal regulator of thyroid function, regulates NIS activity, post-transcriptional events have been suggested to play a role (Kaminsky, S. M., Levy, O., Salvador, C., Dai, G., and Carrasco, N. (1994) *Proc. Natl. Acad. Sci. U. S. A.* 91, 3789–3793). Here we show that TSH induces *de novo* NIS biosynthesis and modulates the long NIS half-life (~5 days). In addition, we demonstrate that TSH is required for NIS targeting to or retention in the plasma membrane. We further show that NIS is a phosphoprotein and that TSH modulates its phosphorylation pattern. These results provide strong evidence of the major role played by post-transcriptional events in the regulation of NIS by TSH. Beyond their inherent interest, it is also of medical significance that these TSH-dependent regulatory mechanisms may be altered in the large proportion of thyroid cancers in which NIS is predominantly expressed in intracellular compartments, instead of being properly targeted to the plasma membrane.

The Na⁺/I⁻ symporter (NIS)¹ is an intrinsic plasma membrane protein that mediates the active transport of I⁻ in the thyroid and other tissues such as salivary glands, gastric mucosa, and lactating mammary gland (1, 2). NIS is of central significance in thyroid pathophysiology as the route by which I⁻ reaches the gland for thyroid hormone biosynthesis and as a means for diagnostic scintigraphic imaging and for radioiodide therapy in thyroid cancer (3). NIS couples the inward translocation of Na⁺ down its electrochemical gradient to the simul-

taneous inward translocation of I⁻ against its electrochemical gradient (4–6) with a 2:1 Na⁺/I⁻ stoichiometry (6). Cloning and sequencing of the rat NIS cDNA revealed a protein of 618 amino acids (7), which is highly homologous (87% identity) to the subsequently cloned human NIS (8). The current secondary structure model depicts NIS as a protein with 13 transmembrane segments, the amino terminus facing the extracellular side and the carboxyl terminus facing the cytosol, both of which we have demonstrated experimentally (9).

The iodine-containing thyroid hormones triiodothyronine and thyroxine play essential roles in promoting the development and maturation of the nervous system, skeletal muscle, and lungs and in regulating intermediary metabolism in virtually all tissues. Thyroid-stimulating hormone (TSH) is the primary hormonal regulator of thyroid function overall and has long been known to stimulate I⁻ uptake activity in the thyroid (10). No thyroidal I⁻ uptake is detected in humans whose serum TSH levels are suppressed (11). In addition, up-regulation of NIS thyroid expression and I⁻ uptake activity by TSH has been demonstrated in rats *in vivo* (12), in the rat thyroid-derived FRTL-5 cell line (13), and in human thyroid primary cultures (14, 15). TSH up-regulates I⁻ uptake activity by a cAMP-mediated increase in NIS transcription (13, 16–18). After TSH withdrawal a reduction of both intracellular cAMP levels and I⁻ uptake activity is observed in FRTL-5 cells. This is a reversible process, as I⁻ uptake activity can be restored either by TSH or agents that increase cAMP (13, 18). I⁻ uptake activity surprisingly persists in membrane vesicles (MV) prepared from FRTL-5 cells that, when intact, have completely lost I⁻ uptake activity due to prolonged TSH deprivation (19). This suggests that mechanisms other than transcriptional might also operate to regulate NIS activity in response to TSH.

Here we provide evidence for post-transcriptional regulation of NIS function by TSH. Our results show for the first time that NIS is a phosphoprotein and that the NIS phosphorylation pattern is regulated by TSH. Furthermore, our data indicate that in the absence of TSH, NIS is redistributed from the plasma membrane to intracellular compartments. This suggests that under TSH deprivation, the loss of I⁻ transport activity in FRTL-5 cells is due to NIS intracellular distribution. Interestingly and contrary to expectations, NIS is overexpressed in some thyroid cancers, notwithstanding their decreased I⁻ uptake activity (20, 21).² Moreover, overexpressed NIS in these cells is predominantly retained intracellularly.² The intracellular NIS redistribution pattern that we observed in FRTL-5 cells maintained in the absence of TSH resembles that reported in thyroid tumors, underscoring the importance of elucidating the mechanisms that govern the subcellular localization of NIS.

* This work was supported in part by the National Institutes of Health Grant DK-41544 (to N. C.). The costs of publication of this article were defrayed in part by the payment of page charges. This article must therefore be hereby marked "advertisement" in accordance with 18 U.S.C. Section 1734 solely to indicate this fact.

§ Supported by the United States Army Medical Research and Materiel Command Office Award BC990754.

¶ Supported by the National Institutes of Health Hepatology Research Training Grant DK-07218. Current address: Wyeth-Lederle Vaccines, 401 North Middletown Rd. 180/216-17, Pearl River, NY 10965.

|| To whom correspondence should be addressed: Dept. of Molecular Pharmacology, Albert Einstein College of Medicine, 1300 Morris Park Ave., Bronx, New York 10461. Tel.: 718-430-3523; Fax: 718-430-8922; E-mail: carrasco@aecom.yu.edu.

¹ The abbreviations used are: NIS, Na⁺/I⁻ symporter; TSH, thyroid-stimulating hormone; MV, membrane vesicles; PMSF, phenylmethanesulfonyl fluoride; HBSS, Hanks' balanced salt solution; Ab, antibody; PBS, phosphate-buffered saline; RT, room temperature; Sulfo-NHS-SS-biotin, sulfosuccinimidyl-2-(biotinamido)ethyl-1,3-dithiopropionate.

² Dohán, O., Baloch, Z., Banrevi, Z., Livolsi, V., and Carrasco, N. (2001) *JCEM* 86, in press.

EXPERIMENTAL PROCEDURES

Cell Culture—FRTL-5 rat thyroid cells, kindly provided by Dr. L. D. Kohn (National Institutes of Health, Bethesda, MD), were grown in Ham's F-12 media (Life Technologies, Inc.) supplemented with 5% calf serum, 1 mM non-essential amino acids (Life Technologies, Inc.), 10 mM glutamine, 100 units/ml penicillin, 100 μ g/ml streptomycin, and a six-hormone mixture (6H) containing insulin (1.3 μ M), hydrocortisone (1 μ M), transferrin (60 pM), L-glycyl-histidyl-lysine (2.5 μ M), somatostatin (6.1 nM), and TSH (1 milliunits/ml) as reported previously (23). Cells were grown in a humidified atmosphere with 5% CO₂ at 37 °C. To study the effect of TSH deprivation, FRTL-5 cells were kept in the same medium without TSH (5H). FRTL-5 cells are viable in this medium for at least 15 days (23). TSH was obtained from the National Hormone Pituitary Program, and all other reagents were purchased from Sigma.

Preparation of Membrane Vesicles (MV)—MV for I⁻ transport were prepared as described previously (19). Briefly, FRTL-5 cells kept in TSH(+) or TSH(-) medium were washed, harvested, and resuspended in ice-cold 250 mM sucrose, 1 mM EGTA, 10 mM Hepes-KOH (pH 7.5), containing aprotinin (90 μ g/ml) (Roche Molecular Biochemicals), leupeptin (4 μ g/ml) (Roche Molecular Biochemicals), and phenylmethanesulfonyl fluoride (PMSF) (0.8 mM) (Sigma). Cells were disrupted with a motor-driven Teflon pestle homogenizer. The homogenate was centrifuged twice at 500 \times g for 15 min at 4 °C, and the supernatant was centrifuged at 100,000 \times g for 1 h at 4 °C. The pellet was resuspended in ice-cold 250 mM sucrose, 1 mM MgCl₂, 10 mM Hepes-KOH (pH 7.5), aliquoted, and stored in liquid nitrogen.

MV for immunoblot analysis were prepared as described above except that the final pellet was resuspended in 250 mM sucrose, 1 mM EGTA, 10 mM Hepes-KOH (pH 7.5).

I⁻ Transport in Intact Cells and MV—I⁻ transport assays in intact cells were performed with 90% confluent FRTL-5 cells in 12-well plates that were kept either in 6H or 5H medium (23). Briefly, after aspirating the culture medium, cells were washed two times with 0.5 ml of modified Hanks' balanced salt solution (HBSS). Cells were incubated with HBSS buffer containing 20 μ M Na¹²⁵I (specific activity 50 Ci/mol) for 45 min at 37 °C in a humidified atmosphere with 5% CO₂. Reactions were terminated by aspirating the radioactive solution and washing three times with cold HBSS. Intracellular ¹²⁵I⁻ was released by permeabilizing the cells with 500 μ l of 95% cold ethanol and was quantitated in a γ -counter. DNA in each well was determined by the diphenylamine method (19). I⁻ uptake was expressed as picomoles of I⁻ per μ g of DNA in each well.

FRTL-5 MV were assayed as described (19). MV were thawed at 37 °C and placed on ice. Aliquots containing 50 μ g of protein (10 μ l) were assayed for ¹²⁵I⁻ uptake by incubating at room temperature (RT) with an equal volume (10 μ l) of a solution containing 20 μ M Na¹²⁵I (specific activity 1.1 Ci/mmol), 1 mM MgCl₂, 10 mM Hepes-KOH (pH 7.5), 2 mM methimazole, 200 mM NaCl, 30 μ M NaClO₄. Reactions were terminated at the 30-s time point by the addition of 3 ml of ice-cold quenching solution: 250 mM KCl, 1 mM methimazole, and 1 mM Tris-HCl (pH 7.5), followed by rapid filtration through wet nitrocellulose filters (0.45- μ m pore diameter). Radioactivity retained by MV was determined by quantitating filters in γ -counter. Data were standardized per mg of protein.

Immunoblot Analysis—SDS-9% polyacrylamide gel electrophoresis and electroblotting to nitrocellulose were performed as described previously (12). Samples were diluted 1:2 with loading buffer and heated at 37 °C for 30 min prior to electrophoresis. Immunoblot analyses were also carried out as described (12) with 930 pM of affinity-purified anti-NIS polyclonal antibody (Ab) and 1:1500 of a horseradish peroxidase-linked goat anti-rabbit IgG (Amersham Pharmacia Biotech). Proteins were visualized by an enhanced chemiluminescence Western blot detection system (Amersham Pharmacia Biotech).

Metabolic Labeling and Immunoprecipitation—Metabolic labeling and immunoprecipitation were performed as described previously (12). Briefly, FRTL-5 cells in 60-mm plates kept in the presence or absence of TSH were washed and incubated for 30 min with cysteine- and methionine-free RPMI 1640 medium supplemented with dialyzed 5% calf serum. Cells were labeled with 480 μ Ci/ml [³⁵S]methionine/cysteine (Promix, DuPont) for the indicated times, followed by washes and incubation with regular media supplemented with 10 \times methionine/cysteine for the indicated times. Cells were lysed with 1% SDS in PBS containing aprotinin (90 μ g/ml), leupeptin (4 μ g/ml), and PMSF (0.8 mM), followed by a 16-fold dilution with 1% Triton X-100, 1% deoxycholate, 200 mM NaCl, 1% BSA, 50 mM Tris-HCl (pH 7.5). Preimmune serum and protein G fast flow Sepharose beads (Amersham Pharmacia

Biotech) were added and incubated at 4 °C for 60 min. Lysate was centrifuged at 100,000 \times g for 30 min. Supernatants were incubated with 1:40 dilution of anti-NIS antisera for 60 min at 4 °C, followed by the addition 30% of a slurry of protein G fast flow Sepharose beads incubated at 4 °C for 60 min. Beads were centrifuged at 14,000 \times g for 5 min and alternately washed with low ionic strength buffer (150 mM NaCl, 1% Triton X-100, 1% deoxycholate, 1 mM EDTA, 10 mM Tris-HCl (pH 7.5)), with high ionic strength buffer (150 mM NaCl, 1% Triton X-100, 1% deoxycholate, 1 mM EDTA, 0.5 M LiCl, 10 mM Tris-HCl (pH 7.5)), and with 10 mM Tris-HCl (pH 7.5). Samples were heated at 37 °C for 30 min in loading buffer prior to SDS electrophoresis. Gels were fixed and soaked in Fluoro-Hance (Research Products International). Gels were vacuum-dried and exposed for autoradiography at -70 °C.

Cell Surface Biotinylation—Cell surface biotinylation was performed in FRTL-5 cells kept in 6H or 5H medium as a modification of a method described previously (24). Cells were grown in 12-well plates to 80% confluence. Cells were washed with PBS/CM (PBS with 0.1 mM CaCl₂ and 1 mM MgCl₂) and incubated twice for 20 min at 4 °C with 1.5 mg/ml sulfo-succinimidyl-2-(biotinamido)ethyl-1,3-dithiopropionate (Sulfo-NHS-SS-biotin) (Pierce) in 20 mM Hepes (pH 8.5), 2 mM CaCl₂, and 150 mM NaCl. Cells were washed twice for 20 min with PBS/CM-containing 100 mM glycine at 4 °C and lysed with 1% SDS in 150 mM NaCl, 5 mM EDTA, 1% of Triton X-100, 50 mM Tris (pH 7.5) containing aprotinin (90 μ g/ml), leupeptin (4 μ g/ml), and PMSF (0.8 mM), referred to as buffer A. Samples were diluted 10 \times with buffer A without SDS. Streptavidin-agarose beads (Pierce) were added to the lysate and incubated overnight at 4 °C. The next day the lysate was centrifuged at 14,000 \times g for 5 min to separate beads from the supernatant. Beads were washed 3 \times with buffer A without SDS and 2 \times with high ionic strength buffer (500 mM NaCl, 0.1% Triton X-100, 5 mM EDTA, and 50 mM Tris-HCl (pH 7.5)). The final wash was done with 50 mM Tris-HCl (pH 7.5). Beads were resuspended in sample buffer and heated for 5 min at 75 °C.

Immunofluorescence—FRTL-5 cells in the presence of TSH were seeded onto poly-(lysine)-coated coverslips. Forty eight hours after seeding, cells were changed to 6H or 5H for the indicated times. Cells were washed 3 \times with PBS/CM, fixed with 2% paraformaldehyde in PBS for 20 min at RT, and rinsed with PBS/CM. Cells were permeabilized with 0.1% Triton in PBS/CM plus 0.2% BSA (PBS/CM/TB) for 10 min at RT. Cells were quenched with 50 mM NH₄Cl in PBS/CM for 10 min at RT and rinsed with PBS/CM/TB. Cells were incubated with 8 nM anti-NIS Ab in PBS/CM/TB for 1 h at RT, washed, and incubated with 1:700 dilution of fluorescein-labeled goat anti-rabbit Ab (Vector Laboratories). After washing, cells on the coverslips were mounted onto microscope slides using an antifade kit from Molecular Probes. Coverslips were sealed with quick-dry nail polish and allowed to dry in the dark for 2 h at RT and stored at 4 °C. NIS immunofluorescence was analyzed with a Bio-Rad Radianc 2000 Laser Scanning Confocal MRC 600, equipped with a Nikon Eclipse epifluorescent microscope.

³²P in Vivo Labeling—³²P in vivo labeling was performed as described previously (25). Cells were grown to 70–80% confluency in 100-mm tissue culture plates and incubated for 30 min in 4 ml of phosphate-free Dulbecco's modified Eagle's medium (Sigma) supplemented with 5% calf serum. Then 100 μ Ci/ml ortho[³²P]phosphoric acid (P_i) (DuPont) was added to the culture medium and incubated for 5 h at 37 °C. Cells were lysed with 1% SDS in PBS containing phosphate inhibitors (50 nM calyculin (Sigma), 10 mM NaF, 2 mM EDTA, 4 μ M cantharidin (Sigma), 2 mM vanadate, and 100 μ M phenylarsyn oxide (Calbiochem)) and protease inhibitors (3 μ g/ml leupeptin, 2 μ g/ml aprotinin, and 0.8 mM PMSF). After lysis, NIS was immunoprecipitated, subjected to electrophoresis, and electrotransferred to nitrocellulose. NIS was visualized by autoradiography after 3 h at -70 °C. The NIS band was excised from the nitrocellulose and digested with trypsin as described (26). Briefly, nitrocellulose strips were treated with 0.5% polyvinylpyrrolidone-30 in 100 mM acetic acid for 30 min, washed with water, and digested with L-1-tosylamido-2-phenylethyl chloromethyl ketone-treated trypsin (10 μ g) (Worthington) in 100 mM NH₄HCO₃ (pH 8.2), 1 mM CaCl₂ for 24 h at 37 °C. Under these conditions, ~60% of the ³²P was released from the nitrocellulose.

Two-dimensional Tryptic Phosphopeptide Mapping of in Vivo Labeled NIS—The phosphopeptide map was performed as described previously (25). Tryptic phosphopeptides were separated in two dimensions on cellulose thin layer plates by electrophoresis at pH 1.9 for 50 min at 650 V, followed by chromatography (1-butanol/pyridine/acetic acid/H₂O, 50:33:1:40, v/v). Approximately 1000 and 500 cpm were loaded onto each plate from TSH(+) and TSH(-) cells, respectively. Plates were visualized by autoradiography after 3 days at -70 °C.

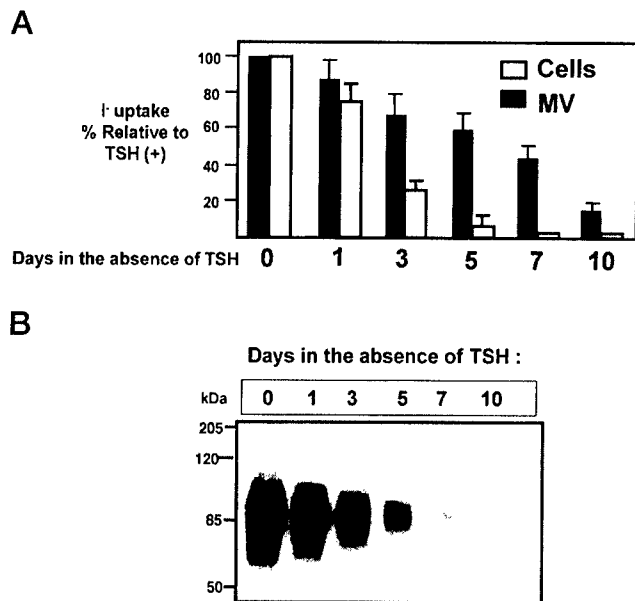

FIG. 1. TSH regulates I^- transport and NIS expression in FRTL-5 cells. *A*, I^- transport activity. FRTL-5 cells were kept in the presence or absence of TSH for the indicated number of days. I^- transport was measured in intact cells (*empty bars*) and in membrane vesicles (MV) prepared from these cells (*filled bars*). I^- transport measured in cells maintained in the presence of TSH and in their MV was defined as 100%. I^- transport corresponding to days 1, 3, 5, 7, and 10 after TSH removal was expressed as the percentage of I^- transport relative to day 0. The values represent the means \pm S.E. of at least four independent experiments performed in triplicate. *B*, NIS expression in FRTL-5 cells. MV from FRTL-5 cells were prepared, electrophoresed, and analyzed by Western blot using a high affinity anti-NIS Ab as described under "Experimental Procedures." The NIS protein corresponds to the \sim 85-kDa broad band.

RESULTS

TSH Differentially Regulates NIS Expression and I^- Uptake Activity in FRTL-5 Cells—We measured Na^+ -dependent, perchlorate-inhibitable (*i.e.* NIS-mediated) I^- uptake activity in intact FRTL-5 cells over the course of 10 days after TSH was removed from the culture medium and in MV prepared from these cells (Fig. 1A). MV are a pool of sealed vesicles from all subcellular compartments except the nuclear membrane. As reported previously (19), while I^- transport activity decreased by 75% in intact cells 3 days after removal of TSH (Fig. 1A, *empty bars*), I^- transport activity only decreased by 25% in MV (Fig. 1A, *filled bars*). By 5 days after TSH withdrawal, I^- uptake was completely abolished in intact cells, whereas in MV it was still as high as 60% of the initial activity. To determine whether the reduction of I^- uptake in intact cells was due to a decrease in NIS expression, we subjected MV from these cells to immunoblot analysis with anti-NIS Ab (Fig. 1B), and we monitored the \sim 85-kDa broad band corresponding to fully glycosylated NIS (12). Although NIS expression decreased to \sim 50% of its initial level after 3 days of TSH deprivation, NIS expression in MV remained detectable after 7–10 days (Fig. 1B), *i.e.* even after I^- uptake in intact cells was completely abolished (Fig. 1A). That I^- transport activity in MV from TSH-deprived cells persists during the entire time course is consistent with NIS expression in these cells.

TSH Is Required for *de Novo* NIS Biosynthesis—To test whether NIS is synthesized in the absence of TSH, cells that had been deprived of TSH for 5 days were metabolically labeled for 10 min with [^{35}S]methionine/cysteine and chased for 8 h. NIS immunoprecipitation and SDS-polyacrylamide gel electro-

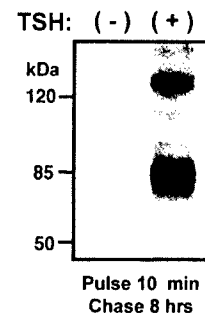

FIG. 2. *De novo* synthesis of NIS requires TSH. FRTL-5 cells maintained in the presence or absence of TSH for 5 days were metabolically labeled with 480 μ Ci/ml [^{35}S]methionine/cysteine for 10 min. Cells were chased for 8 h and lysed. NIS was immunoprecipitated with anti-NIS Ab and electrophoresed. The \sim 85-kDa broad band corresponds to the NIS monomer and the \sim 160-kDa to the dimer.

phoresis analysis showed that *de novo* biosynthesis of NIS occurred only when cells were maintained in the presence of TSH (Fig. 2). NIS remained detectable for up to 10 days following TSH deprivation (Fig. 1B), *i.e.* in the absence of *de novo* NIS biosynthesis (Fig. 2), demonstrating that I^- uptake observed in MV from TSH-deprived cells is mediated by NIS molecules synthesized prior to TSH removal.

NIS Half-life Is Modulated by TSH—The observation that NIS remains detectable after prolonged TSH deprivation in the absence of *de novo* NIS biosynthesis suggests that NIS has a long half-life. To determine the precise half-life of NIS and whether it is modulated by TSH, cells maintained in the presence of TSH were pulse-labeled with [^{35}S]methionine/cysteine for 5 min and chased for different times in the presence (Fig. 3A) or absence of TSH (Fig. 3B). As indicated above, NIS migrates as an \sim 85-kDa broad band. The \sim 70-kDa band corresponds to a nonspecific unrelated polypeptide that, unlike NIS, was also immunoprecipitated by preimmune serum (not shown). The half-life of NIS was determined to be \sim 5 days in the presence and \sim 3 days in the absence of TSH (Fig. 3C). This indicates that TSH modulates the long half-life of NIS, increasing it by 40%.

TSH Regulates the Subcellular Distribution of NIS—To assess the effect of TSH on NIS content at the plasma membrane, we performed cell surface biotinylation experiments in the presence of TSH and then over the course of 10 days after TSH was removed from the culture medium. To ensure that only polypeptides facing the extracellular milieu would be biotinylated, we utilized the NH_2 -specific and plasma membrane-impermeable biotinylating reagent Sulfo-NHS-SS-biotin. The entire biotinylated fraction was isolated with streptavidin-coated beads and was immunoblotted with anti-NIS Ab, whereas only 1:50 of the non-biotinylated fraction was loaded onto the gel (Fig. 4, A and B, respectively). Densitometric quantitation of the bands showed that NIS content at the plasma membrane decreased over time after TSH withdrawal in a fashion that correlated very closely with the corresponding decrease in NIS activity in intact cells (Fig. 4C). While 1 day of TSH deprivation causes a similar decrease in both intracellular and cell surface NIS, by 3 days after TSH withdrawal a more pronounced decrease in NIS content was detected at the plasma membrane than in intracellular compartments (Fig. 4C). This indicates that TSH regulates the subcellular distribution of NIS.

The possible regulatory role played by TSH in the subcellular distribution of NIS was further investigated by confocal immunofluorescence analysis of NIS subcellular localization in response to TSH withdrawal over a 10-day period (Fig. 5). As anti-NIS Ab recognizes a cytosol-facing epitope of NIS (*i.e.* the

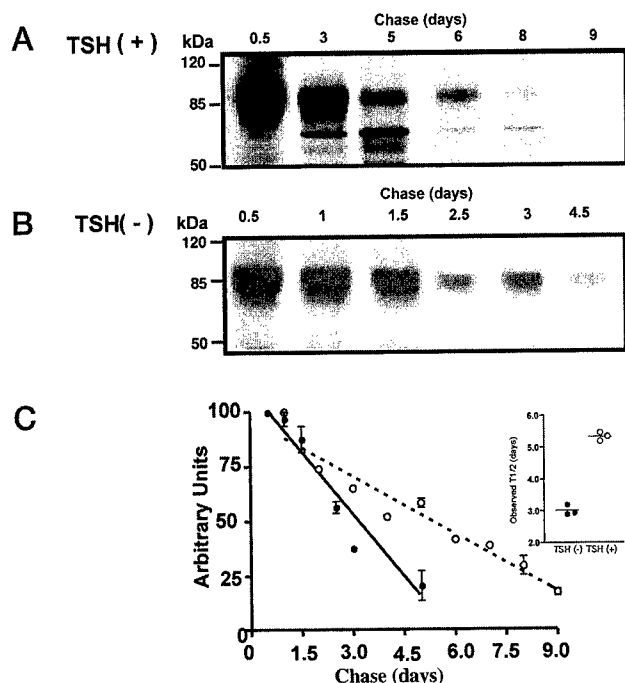

FIG. 3. NIS has a long half-life, which is modulated by TSH. To determine the half-life of NIS, FRTL-5 cells were pulsed for 5 min with $480 \mu\text{Ci/ml}$ of [^{35}S]methionine/cysteine in the presence of TSH. During the chase period an aliquot of cells was maintained in the presence of TSH (A) and a second aliquot kept in the absence of TSH (B). Chase periods are indicated in the horizontal axis. Samples were processed as described in Fig. 2. NIS bands were subjected to densitometric analysis (NIH program) for quantitation (TSH(-), circles and continuous line, TSH(+), squares and dotted line). C, inset, scatter plot of NIS half-life from three independent experiments in the presence (+) and absence (-) of TSH. Student's *t* test (unpaired) yielded $p < 0.0001$. Data fitting, S.D., and Student's *t* test calculations were done with the PrismTM 2.0 software (GraphPad, San Diego, CA).

carboxyl terminus), cells were fixed and permeabilized prior to incubation with the Ab. Given that NIS expression decreases after TSH deprivation, images were taken with different exposure times. In the presence of TSH, FRTL-5 cells predominantly displayed a stark immunofluorescent staining delineating the periphery of the cells, strongly indicative of plasma membrane localization for NIS (Fig. 5, 0 days). Some intracellular staining was also observed. The cell surface staining pattern decreased slowly after removal of TSH, disappearing completely by day 3, at which point only an intracellular pattern remained. The intracellular NIS pattern observed on day 3 was punctate and spread throughout the cytoplasm. In contrast, by days 5–10 the NIS punctate distribution decreased noticeably and was localized further from the perinuclear region. Immunofluorescence was abolished by preincubation of the Ab with antigen peptide or when the second but not the first Ab was added, indicating that the observed staining is specific for NIS (12). These observations are consistent with the biotinylation findings described above (Fig. 4), suggesting that TSH is required for NIS localization at the cell surface. Therefore, the absence of TSH over time causes NIS to mainly redistribute to and/or remain in intracellular compartments. These data support the notion that in addition to regulating NIS expression, TSH also regulates the subcellular distribution of NIS. In the absence of TSH, not only is *de novo* NIS biosynthesis nonexistent (Fig. 2) but NIS is increasingly re-distributed from the plasma membrane to intracellular compartments over time (within the 3–7-day range).

TSH Modulates NIS Phosphorylation—The mechanism by which TSH regulates the subcellular distribution of NIS is unknown. Phosphorylation has been shown to be implicated in

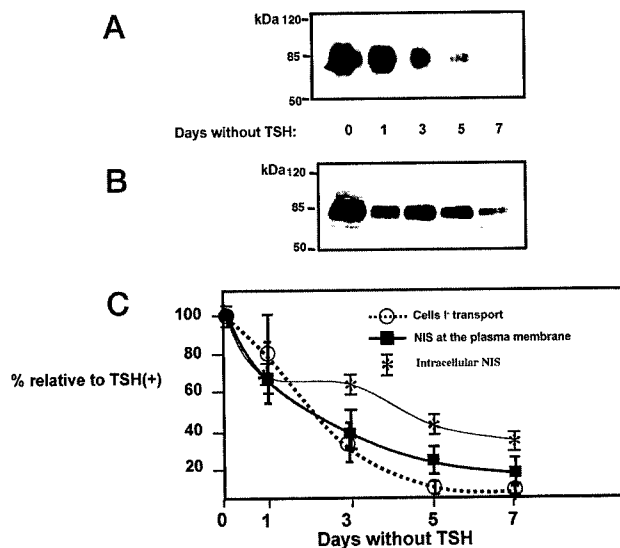

FIG. 4. NIS at the cell surface decreases in close correlation with I^- transport after TSH withdrawal. Cell surface biotinylation experiments were performed in FRTL-5 cells that were kept in the presence or absence of TSH. Cells were biotinylated with Sulfo-NHS-SS-biotin, a membrane-impermeable reagent, and lysed, and biotinylated proteins were separated from non-biotinylated proteins by precipitation with streptavidin. The membrane impermeability of Sulfo-NHS-SS-biotin was verified by demonstrating that the intracellular protein actin was not biotinylated (not shown). All biotinylated proteins (A) and 1:50 of the supernatant containing the non-biotinylated intracellular proteins (B) were electrophoresed, electrotransferred to nitrocellulose, and immunoblotted with anti-NIS Ab. Equivalent protein amounts were loaded on each lane, as assessed by immunoblot analysis with anti-actin Ab (data not shown). Hence, A shows NIS content at the plasma membrane, and B shows 1:50 of NIS content in intracellular compartments. C, NIS bands from both immunoblots were subjected to densitometric analysis (NIH program) for quantitation (squares, biotinylated NIS; asterisks, non-biotinylated NIS), and the results were plotted along with the corresponding I^- transport activity values from intact cells (circles). All values were expressed as percentage relative to day 0. Values represent the means \pm S.E. of at least three independent experiments.

activation and subcellular distribution of several transporters (27–32). NIS has several consensus sites for kinases, including those for cAMP-dependent protein kinase, protein kinase C, and CK-2. Furthermore, TSH actions in the thyroid are mainly mediated by cAMP, raising the possibility that phosphorylation might be involved in the regulation of NIS distribution. FRTL-5 cells were labeled with $^{32}\text{P}_i$ for 5 h and lysed. NIS was immunoprecipitated with anti-NIS Ab, and the immunoprecipitate was subjected to electrophoresis. The autoradiogram revealed that NIS was phosphorylated, independently of the presence of TSH in the culture medium (Fig. 6A). Given the decreased expression of NIS in TSH-deprived cells, the amount of ^{32}P -NIS was considerably lower in these cells than in those grown in the presence of the hormone. To assess whether NIS phosphorylation is modulated by TSH, we performed $^{32}\text{P}_i$ labeling in the presence or absence of TSH, and immunoprecipitated ^{32}P -labeled NIS was subjected to digestion with trypsin as described under “Experimental Procedures.” The phosphopeptide map obtained when TSH was present was markedly different from that when TSH was absent (Fig. 6B). Five phosphopeptides were resolved in the presence and three in the absence of TSH. Only one among these eight phosphopeptides seemed to be common to both conditions (number two for TSH(+)) and number eight for TSH(-)) as calculated by the migration coefficient. These results indicate that NIS is a phosphoprotein and that the NIS phosphorylation pattern is modulated by TSH.

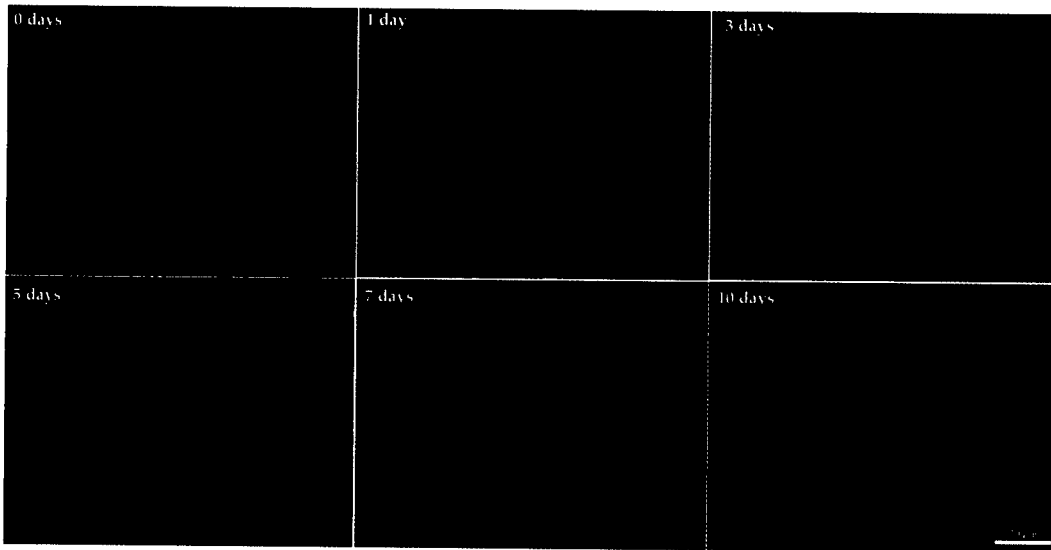

FIG. 5. NIS is redistributed to intracellular compartments during TSH deprivation. NIS staining was performed in FRTL-5 cells with anti-NIS Ab. Cells were maintained in the presence or absence of TSH for the indicated number of days. NIS immunofluorescence in these cells was analyzed by confocal microscopy as described under "Experimental Procedures." Magnification was $\times 60$.

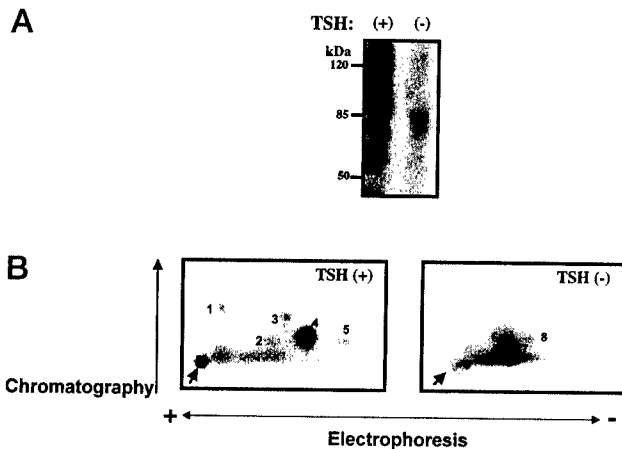

FIG. 6. NIS is a phosphoprotein, and its phosphorylation pattern is modulated by TSH. FRTL-5 cells were grown to 70% confluence in 100-mm tissue culture plates in the presence or absence of TSH for 5 days. Cells were labeled *in vivo* with $100 \mu\text{Ci/ml}$ ^{32}P for 5 h at 37°C . Cells were lysed, and NIS was immunoprecipitated with anti-NIS Ab, electrophoresed, and electrotransferred to nitrocellulose. ^{32}P -labeled NIS was visualized after autoradiography at -70°C for 3 h (A). NIS bands were excised from the nitrocellulose and digested with trypsin. Tryptic phosphopeptides were separated in two dimensions on cellulose thin layer plates by electrophoresis (pH 1.9) for 50 min at 650 V, followed by thin layer chromatography. Phosphopeptides were visualized by autoradiography (B).

DISCUSSION

The regulation of membrane transport proteins is a highly complex process that takes place at various levels (33–35). Here we show that this is the case for NIS regulation. NIS, being the transporter that mediates the first step (*i.e.* active I^- uptake) in thyroid hormone biosynthesis, provides a suitable regulatory target for TSH, which is the primary hormonal regulatory factor of thyroid function overall. It has long been clear that TSH stimulates thyroidal I^- uptake by up-regulating NIS transcription via cAMP (13, 17, 18). Our findings provide convincing experimental evidence that TSH also regulates NIS by post-transcriptional mechanisms.

With our high affinity anti-NIS Ab we demonstrated conclusively by immunoblot analysis that NIS is present in FRTL-5 cells as late as 10 days after TSH withdrawal (Fig. 1B) and that

de novo NIS biosynthesis requires TSH (Fig. 2). Therefore, it is clear that any NIS molecules detected in TSH(-) FRTL-5 cells had to be synthesized prior to TSH withdrawal. This is consistent with NIS being a protein with an exceptionally long half-life, as suggested previously (17, 36). Indeed, by pulse-chase analysis we determined that NIS half-life is ~ 5 days in the presence and ~ 3 days in the absence of TSH (Fig. 3). Even though the NIS half-life in the absence of TSH is 40% shorter than in the presence of the hormone, it is still sufficiently long to account for the persistence of significant I^- uptake activity in MV from cells deprived of TSH (Fig. 1). It was the detection of this vesicular activity that first led to the suggestion that NIS might be regulated post-transcriptionally (19), a notion further supported by several subsequent reports (17, 36). In addition, it has recently been shown (14) that TSH markedly stimulates NIS mRNA and protein levels in both monolayer and follicle-forming human primary culture thyrocytes, whereas significant stimulation of I^- uptake is observed only in follicles, suggesting that NIS may be regulated by such post-transcriptional events as subcellular distribution.

Several transporters are modulated by post-transcriptional regulation of their trafficking to the plasma membrane and/or by internalization from the plasma membrane to intracellular compartments (37, 38). For example, the glucose transporter 4 (GLUT4) (35) is targeted to the plasma membrane in response to insulin, whereas the serotonin transporter is internalized in the presence of its antagonist cocaine (27). Therefore, it seems feasible that regulation of the subcellular distribution of NIS might also be a mechanism involved in modulating I^- uptake. We have shown a remarkably close correlation between NIS plasma membrane content and NIS activity (Fig. 4C), demonstrating that the progressive loss of NIS activity after TSH withdrawal is due to a decrease in the amount of NIS present at the cell surface. Furthermore, we observed that 3 days after TSH deprivation, intracellular NIS decreases at a slower rate than plasma membrane NIS (compare Fig. 4, A and B). These data support the notion that active NIS molecules, initially located in the plasma membrane while TSH is present, are redistributed to intracellular compartments in response to TSH withdrawal despite the lack of *de novo* NIS synthesis and the 40% reduction of the NIS half-life. This model explains the presence of NIS activity in MV from cells deprived of TSH that, when intact, exhibit no NIS activity. Clearly, TSH regulates I^-

uptake by modulating the subcellular distribution of NIS, without apparently influencing the intrinsic functional status of the NIS molecules, as proposed previously (19). In conclusion, TSH not only stimulates NIS transcription and biosynthesis, it is also required for targeting NIS to and/or retaining it at the plasma membrane. Future experiments might distinguish between these two possibilities.

The precise mechanism by which TSH regulates NIS distribution remains to be fully explored. NIS exhibits several consensus sites for the cAMP-dependent protein kinase, protein kinase C, and CK-2 kinases. We have observed that NIS is phosphorylated (Fig. 6A) and that the NIS phosphorylation pattern differs when cells are in the presence as compared to the absence of TSH (Fig. 6B). This demonstrates that TSH modulates NIS phosphorylation. Therefore, given that phosphorylation has been reported to play a role in regulating targeting of other transporters, such as the serotonin (27), vesicular monoamine (29), vesicular acetylcholine (30), γ -aminobutyric acid (28), organic cation (OCT1) (31), and hepatocyte organic anion transporters (32), it will be of considerable interest to investigate whether NIS phosphorylation plays a role in NIS targeting as well.

The multifaceted TSH-NIS regulatory interaction shown here represents a key link in the negative feedback loop involving TSH and the thyroid hormones. First, the mentioned TSH actions on NIS lead, by different but mutually reinforcing mechanisms (*i.e.* transcriptional and post-transcriptional), to stimulation of I^- uptake resulting in higher thyroid hormone production and release. Then, a rise in thyroid hormone circulating levels ultimately inhibits TSH release in the pituitary gland, and this decreases I^- uptake in the thyroid.

The results presented here are highly relevant to thyroid cancer. It is of major diagnostic importance that most thyroid cancers exhibit decreased I^- uptake relative to the surrounding tissue on scintigraphy (11). Conversely, the ability of thyroid cancer cells to sufficiently transport I^- is the basis for radioiodide therapy to be effective against remnant thyroid malignant cells or metastasis after thyroidectomy. Because of the decrease in I^- uptake observed in thyroid cancer, it had long been expected that NIS expression would be decreased in thyroid cancer cells. However, NIS has surprisingly been shown in numerous thyroid cancers to be actually overexpressed but retained intracellularly.² This suggests that malignant transformation of thyroid cells interferes with the distribution of NIS to the plasma membrane. Interestingly, we have also observed both plasma membrane and intracellular NIS expression in breast cancer (1). The research presented here provides insight into the post-transcriptional mechanisms involved in the regulation of NIS by TSH. These are some of the very mechanisms that may be affected in thyroid cancer. Whereas several researchers have focused on finding ways to induce NIS transcription in thyroid cancer (22, 39), our findings indicate that an understanding of the regulatory processes of NIS biosynthesis, targeting, and trafficking is necessary for the development of complementary strategies to enhance the I^- transport ability of thyroid cancers and increase the effectiveness of radioiodide therapy in these cases.

Acknowledgments—We are grateful Drs. A. De la Vieja, O. Dohan, M. Amzel, and A. Kalergis for their valuable contributions, insightful discussions, and critical reading of the manuscript. We thank Drs. J. Glavy and G. Orr for help and advice with phosphorylation experiments. We also thank Drs. M. Charron, P. Arvan, E. B. Katz, C. Harley, and A. Dasgupta for critical reading of the manuscript.

REFERENCES

1. Tazebay, U. H., Wapnir, I. L., Levy, O., Dohan, O., Zuckier, L. S., Zhao, Q. H., Deng, H. F., Amenta, P. S., Fineberg, S., Pestell, R. G., and Carrasco, N. (2000) *Nat. Med.* **6**, 871–878
2. De la Vieja, A., Dohan, O., Levy, O., and Carrasco, N. (2000) *Physiol. Rev.* **80**, 1083–1105
3. Mazzaferri, E. L. (2000) in *The Thyroid: A Fundamental and Clinical Text*, (Braverman, L. E., and Utiger, R. D.) 8th Ed, pp. 904–930, J. B. Lippincott, Philadelphia
4. Bagchi, N., and Fawcett, D. M. (1973) *Biochim. Biophys. Acta* **318**, 235–251
5. Weiss, S. J., Philp, N. J., and Grollman, E. F. (1984) *Endocrinology* **114**, 1108–1113
6. Eskandari, S., Loo, D. D., Dai, G., Levy, O., Wright, E. M., and Carrasco, N. (1997) *J. Biol. Chem.* **272**, 27230–27238
7. Dai, G., Levy, O., and Carrasco, N. (1996) *Nature* **379**, 458–460
8. Smanik, P. A., Liu, Q., Furminger, T. L., Ryu, K., Xing, S., Mazzaferri, E. L., and Jhiang, S. M. (1996) *Biochem. Biophys. Res. Commun.* **226**, 339–345
9. Levy, O., De la Vieja, A., Ginter, C. S., Riedel, C., Dai, G., and Carrasco, N. (1998) *J. Biol. Chem.* **273**, 22657–22663
10. Vassart, G., and Dumont, J. E. (1992) *Endocr. Rev.* **13**, 596–611
11. Martino E., Bartalena L., and Pinchera, A. (2000) in *The Thyroid: A Fundamental and Clinical Text*, (Braverman, L. E., and Utiger, R. D.) 8th Ed, pp. 762–773, J. B. Lippincott, Philadelphia
12. Levy, O., Dai, G., Riedel, C., Ginter, C. S., Paul, E. M., Lebowitz, A. N., and Carrasco, N. (1997) *Proc. Natl. Acad. Sci. U. S. A.* **94**, 5568–5573
13. Weiss, S. J., Philp, N. J., Ambesi-Impiombato, F. S., and Grollman, E. F. (1984) *Endocrinology* **114**, 1099–1107
14. Kogai, T., Curcio, F., Hyman, S., Cornford, E. M., Brent, G. A., and Hershman, J. M. (2000) *J. Endocrinol.* **167**, 125–135
15. Saito, T., Endo, T., Kawaguchi, A., Ikeda, M., Nakazato, M., Kogai, T., and Onaya, T. (1997) *J. Clin. Endocrinol. & Metab.* **82**, 3331–3336
16. Marocconi, C., Cohen, J. L., and Grollman, E. F. (1984) *Endocrinology* **115**, 2123–2132
17. Kogai, T., Endo, T., Saito, T., Miyazaki, A., Kawaguchi, A., and Onaya, T. (1997) *Endocrinology* **138**, 2227–2232
18. Ohno, M., Zannini, M., Levy, O., Carrasco, N., and Di Lauro, R. (1999) *Mol. Cell. Biol.* **19**, 2051–2060
19. Kaminsky, S. M., Levy, O., Salvador, C., Dai, G., and Carrasco, N. (1994) *Proc. Natl. Acad. Sci. U. S. A.* **91**, 3789–3793
20. Arturi, F., Russo, D., Giuffrida, D., and Schlumberger, M. (2000) *Eur. J. Endocrinol.* **143**, 623–627
21. Saito, T., Endo, T., Kawaguchi, A., Ikeda, M., Katoh, R., Kawaio, A., Muramatsu, A., and Onaya, T. (1997) *J. Clin. Invest.* **101**, 1296–1300
22. Schmutzler, C., and Kohrle, J. (2000) *Thyroid* **10**, 393–406
23. Weiss, S. J., Philp, N. J., and Grollman, E. F. (1984) *Endocrinology* **114**, 1090–1098
24. Chen, J. G., Liu-Chen, S., and Rudnick, G. (1997) *Biochemistry* **36**, 1479–1486
25. Orr, G. A., Han, E. K., Browne, P. C., Nieves, E., O'Connor, B. M., Yang, C. P., and Horwitz, S. B. (1993) *J. Biol. Chem.* **268**, 25054–25062
26. Luo, K. X., Hurley, T. R., and Sefton, B. M. (1991) *Methods Enzymol.* **201**, 149–152
27. Ramamoorthy, S., and Blakely, R. D. (1999) *Science* **285**, 763–766
28. Law, R. M., Stafford, A., and Quick, M. W. (2000) *J. Biol. Chem.* **275**, 23986–23991
29. Krantz, D. E., Peter, D., Liu, Y., and Edwards, R. H. (1997) *J. Biol. Chem.* **272**, 6752–6759
30. Krantz, D. E., Waites, C., Oorschot, V., Liu, Y., Wilson, R. I., Tan, P. K., Klumperman, J., and Edwards, R. H. (2000) *J. Cell Biol.* **149**, 379–396
31. Mehrens, T., Lelleck, S., Cetinkaya, I., Knollmann, M., Hohage, H., Gorboulev, V., Boknik, P., Koepsell, H., and Schlatter, E. (2000) *J. Am. Soc. Nephrol.* **11**, 1216–1224
32. Glavy, J. S., Wu, S. M., Wang, P. J., Orr, G. A., and Wolkoff, A. W. (2000) *J. Biol. Chem.* **275**, 1479–1484
33. Bradbury, N. A. (1999) *Physiol. Rev.* **79**, 175–191
34. Kopito, R. R. (1999) *Physiol. Rev.* **79**, 167–173
35. Pessin, J. E., Thurmond, D. C., Elmendorf, J. S., Coker, K. J., and Okada, S. (1999) *J. Biol. Chem.* **274**, 2593–2596
36. Paire, A., Bernier-Valentin, F., Selmi-Ruby, S., and Rousset, B. (1997) *J. Biol. Chem.* **272**, 18245–18249
37. Brown, D. (2000) *Am. J. Physiol.* **278**, F192–F201
38. Blakely, R. D., and Bauman, A. L. (2000) *Curr. Opin. Neurobiol.* **10**, 328–336
39. Venkataraman, G. M., Yatin, M., Marcinek, R., and Ain, K. B. (1999) *J. Clin. Endocrinol. & Metab.* **84**, 2449–2457

Journey of the iodide transporter NIS: from its molecular identification to its clinical role in cancer

Claudia Riedel, Orsolya Dohán, Antonio De la Vieja, Christopher S. Ginter and Nancy Carrasco

The Na⁺/I⁻ symporter (NIS) is an intrinsic plasma membrane protein that mediates the active transport of I⁻ in the thyroid, lactating mammary gland, stomach and salivary glands. The presence of NIS in the thyroid is exploited in diagnostic scintigraphic imaging and radioiodide therapy in thyroid cancer. The continued rapid progress in NIS research (aimed at the elucidation of the Na⁺-dependent I⁻ transport mechanism, the analysis of NIS structure- function relations and the study of the tissue-specific regulation of NIS at all levels), holds potentially far-reaching medical applications beyond thyroid disease, in breast cancer and malignancies in other tissues.

Iodide (I⁻) is an essential constituent of the thyroid hormones T₃ and T₄ [tri-iodothyronine and thyroxine (or tetra-iodothyronine), respectively], the only iodine-containing hormones in vertebrates. These hormones are the main regulators of intermediary metabolism in nearly all tissues, and are of fundamental importance for the development of the central nervous system in the fetus and the newborn. However, I⁻ is scarce in the environment. Hence, a remarkably efficient thyroid I⁻ transport system has evolved, ensuring that most of the ingested dietary I⁻ is accumulated in this gland. In addition, comparable I⁻-accumulating systems exist in other tissues, including the lactating mammary gland, the gastric mucosa and the salivary glands¹. Whereas the functional roles of the I⁻ transport systems in the gastric mucosa and the salivary glands are unknown, the I⁻ transport system of the lactating mammary gland is of clear physiological significance: it translocates I⁻ into the milk, making the anion available to the nursing newborn who can then biosynthesize his or her own thyroid hormones.

Notwithstanding the existence of the I⁻ transport system in the thyroid, iodide deficiency disorders (IDDs) remain a major health crisis around the world as a direct result of insufficient dietary intake of I⁻ (Refs 2,3). The clinical manifestations of IDD include hypothyroidism, goiter (enlargement of the thyroid), dwarfism, impaired neurological development and cretinism (the most severe form of IDD). It has been estimated that 30% of the world population is at risk of IDD, that 750 million people suffer from goiter, that 43 million have IDD-related brain damage and mental retardation, and that 5.7 million are afflicted

by cretinism (Ref. 2). These enormous public health problems could be solved by ensuring that all table salt consumed in the affected areas is iodized, as has been done in many countries. However, the sociopolitical realities of the affected regions have often prevented the implementation of such solutions, at great human cost.

Active I⁻ transport in the thyroid, salivary glands, stomach and lactating mammary gland is mediated by the Na⁺/I⁻ symporter (NIS), an intrinsic plasma membrane glycoprotein⁴⁻⁶. A cDNA clone encoding rat NIS (rNIS) has been isolated and encodes a protein of 618 amino acids that is highly homologous to the subsequently cloned human NIS (hNIS, 643 amino acids)⁷. In all tissues where it is functionally expressed, NIS mediates active I⁻ transport by coupling the inward 'downhill' translocation of Na⁺ to the inward 'uphill' translocation of I⁻. Therefore, NIS is a symporter as it translocates both of its substrates (Na⁺ and I⁻) simultaneously and in the same direction. The driving force for NIS-mediated I⁻ transport is the inwardly directed Na⁺ concentration gradient generated by the Na⁺-K⁺ ATPase (Refs 8-11). NIS-mediated I⁻ accumulation is blocked by the specific competitive inhibitors thiocyanate and perchlorate¹¹⁻¹³. In the thyroid, I⁻ accumulation is stimulated by thyroid stimulating hormone (TSH)^{14,15}. In addition, as part of the thyroid hormone biosynthetic pathway, accumulated I⁻ is incorporated into tyrosyl residues on the large thyroglobulin (Tg) molecule in a process known as I⁻ organification¹⁶; iodinated Tg gives rise to T₃ and T₄ (for a detailed description of thyroid hormone biosynthesis see Ref. 16). By contrast, I⁻ accumulation in extrathyroidal tissues is not regulated by TSH (Ref. 9).

The degree of radiiodide accumulation, as detected by thyroid scintigraphy, has been used for over 50 years in the diagnosis and treatment of thyroid pathologies¹⁷. It is clear that the study of NIS, beyond its inherent biochemical and physiological interest, could also have major implications for the development of novel cancer treatments in a wide variety of tissues.

Claudia Riedel
Orsolya Dohán
Antonio De la Vieja
Christopher S. Ginter
Nancy Carrasco*
Albert Einstein College of
Medicine, Dept of
Molecular Pharmacology,
1300 Morris Park Ave.,
Bronx, NY 10461, USA.
*e-mail: carrasco@
aecom.yu.edu

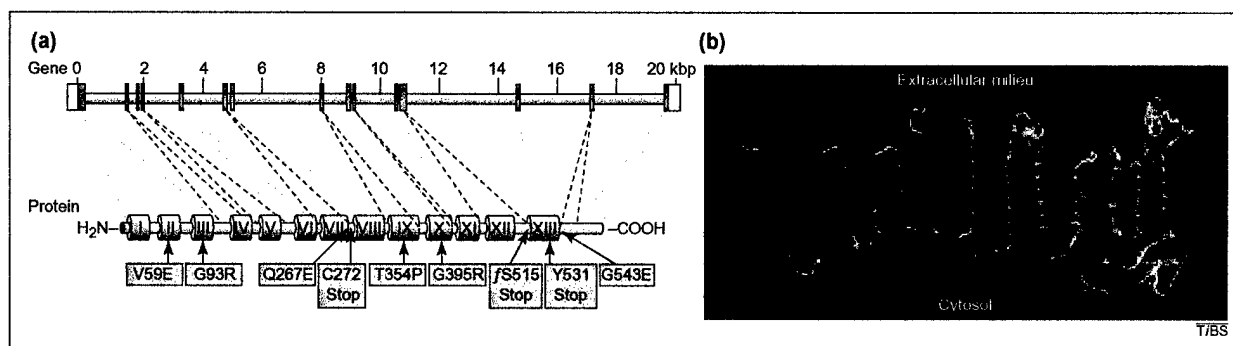

Fig. 1. The human *NIS* (*hNIS*) gene and its correlation with the NIS secondary structure model. (a) The *hNIS* gene is localized on chromosome 19p13 and consists of 15 exons (blue squares) and 14 introns. Exons are shown connected to the corresponding protein regions by dotted lines. Transmembrane segments are represented by cylinders (figure is adapted, with permission, from Ref. 20). Localization of mutations resulting in iodide transport defect (ITD) are indicated by green rectangles. (b) Current NIS secondary structure model. The NH_2 terminus faces the extracellular milieu and the COOH terminus faces the cytosol. Coordinates for the model were obtained with the program QUANTA (Molecular Simulations, Burlington, MA, USA). Regularization of the model was carried out with the program O. Graphics were generated with the program SECTOR.

Molecular characterization of NIS

Dai *et al.*⁴ isolated a single cDNA clone encoding NIS by expression cloning in *Xenopus laevis* oocytes using cDNA libraries derived from FRTL-5 cells (a highly functional rat thyroid-derived cell line¹⁰). The hydrophobic profile and initial secondary structure predictions of the protein suggested an intrinsic membrane protein with 12 putative transmembrane segments in which both the NH_2 and COOH termini were facing intracellularly⁴. This 12-transmembrane segment model has since been experimentally tested and revised. Several phosphorylation sites have been identified in the molecule. Only three charged residues were predicted to lie within transmembrane segments, namely Asp16, Glu79 and Arg208. Four Leu residues (positions 199, 206, 213, 220) appeared to form a putative leucine zipper motif, which could play a role in the potential oligomerization of subunits in the membrane. Freeze-fracture electron microscopy studies of *X. laevis* oocytes expressing NIS revealed the presence of intramembrane particles, 9 nm in size, corresponding to NIS (Ref. 13). The size of these particles suggests that NIS might be an oligomeric protein. NIS is glycosylated at Asn residues 225, 485 and 497. However, glycosylation is not essential for NIS stability, targeting or function¹⁸. The current secondary structure model for NIS proposes 13 transmembrane segments. In addition, immunofluorescence experiments have confirmed the extracellular and cytosolic orientations of the NH_2 and COOH termini, respectively (Fig. 1b)¹⁸. To date, five NIS hydrophilic segments (the NH_2 terminus and loops between transmembrane segments II and III, VI and VII, VIII and IX, and XII and XIII) out of a total of seven, have been experimentally confirmed as having an

external orientation, as predicted in the model (Fig. 1b)¹⁹.

The cDNA encoding hNIS was identified on the expectation that this protein would be highly homologous to the rNIS protein. Using primers to the *rNIS* cDNA sequence, Smanik *et al.*⁷ identified a cDNA clone encoding hNIS. The nucleotide sequence of *hNIS* revealed an open reading frame of 1929 nucleotides, encoding a protein of 643 amino acids. hNIS exhibits 84% identity and 93% similarity to rNIS. hNIS differs from rNIS mostly on account of a five amino acid insertion between the last two hydrophobic domains and a 20 amino acid insertion in the COOH terminus. Subsequently, Smanik *et al.*²⁰ examined the expression, exon-intron organization and chromosome mapping of *hNIS*. Fifteen exons encoding hNIS were found to be interrupted by 14 introns, and the *hNIS* gene was mapped to chromosome 19p13 (Fig. 1a).

NIS belongs to the solute carrier family 5A (OMIM reference for NIS is SLC5A5; <http://www.ncbi.nlm.nih.gov/OMIM>). The SLC5A family includes the high affinity Na^+ -glucose co-transporter family (SLC5A1), the low affinity Na^+ -glucose co-transporter (SLC5A2), the Na^+ -myo-inositol transporter (SLC5A3), the Na^+ -dependent proline symporter (SLC5A4) and the Na^+ -dependent multivitamin transporter (SLC5A6) (Ref. 21). SLC5A6 has the highest homology (42%, Ref. 21) with NIS.

Congenital iodide transport defect (ITD) [OMIM 274400] is an autosomal recessive condition caused by mutations in NIS. In the absence of a functional NIS molecule, there is a sharp decrease in thyroid hormone biosynthesis resulting in hypothyroidism and higher circulating levels of TSH, which in turn cause goiter²². To date, 27 cases of ITD caused by mutations in NIS have been reported and diagnosed at the molecular level⁹. Three different mutations resulting in truncated proteins [C272X, 515X (which is a six amino acid frame shift preceding a stop codon) and Y531X], and six different point mutations resulting in amino acid substitutions (V59E, G93R, Q267E, T354P, G395R and G543E), have been identified (Fig. 1a)⁹. Shortly after isolation of the cDNA that encodes NIS, two groups reported a homozygous missense mutation in patients that had

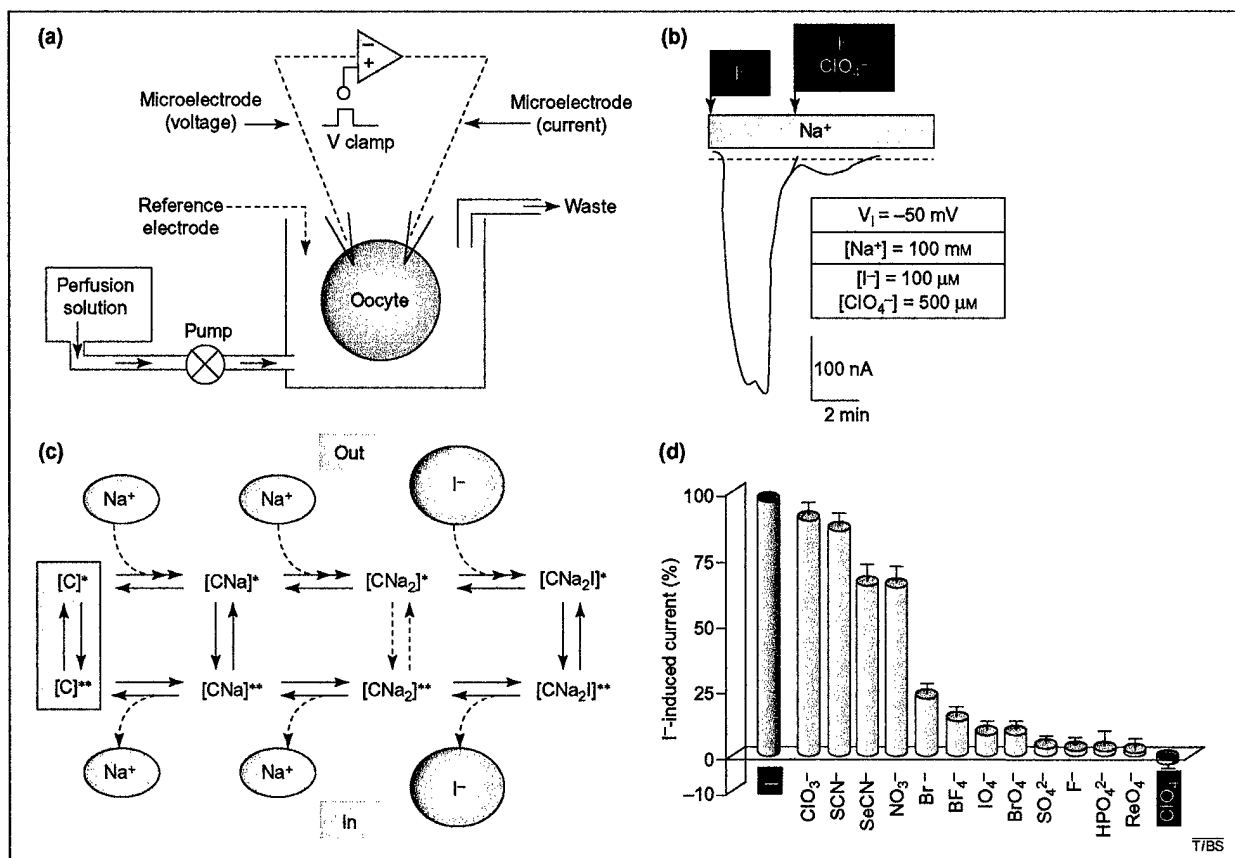

Fig. 2. Electrophysiological characterization of NIS. (a) Two-microelectrode voltage clamp setup for electrophysiological recordings of NIS-expressing *X. laevis* oocytes. *X. laevis* oocytes expressing NIS are placed in a chamber and continuously perfused. Oocytes are pierced with two microelectrodes, one to maintain a constant voltage, the other to register changes in current. (b) Electrogenicity of NIS. Positive inward current generated by Na^+/I^- cotransport. The stoichiometry is $2 \text{ Na}^+ : 1 \text{ I}^-$. Perchlorate (ClO_4^-) completely inhibited the I^- -elicited inward current. (c) The eight-state NIS mechanistic model. Na^+ ions bind NIS before I^- . The Na^+/I^- -NIS complex then undergoes a conformational change to expose bound Na^+ and I^- to the cytosol (in). These substrates are released and the carrier undergoes another conformational change to expose the empty substrate-binding sites to the external milieu (out). In the absence of an anionic substrate, there is a Na^+ -dependent inward current via NIS (Ref. 13). (d) Substrate selectivity of NIS. Inward currents induced by various anions ($500 \mu\text{M}$) were normalized with respect to the current generated by I^- (dark-blue cylinder). ClO_4^- did not generate a current, suggesting that it is not translocated. (c) and (d) are adapted, with permission, from Ref. 13.

the amino acid residue at position 354 is essential for NIS function.

Significantly, transmembrane segment IX is the helix with the highest incidence of hydroxyl-containing amino acids. De la Vieja *et al.*²⁶ assessed the role of these other hydroxyl groups on NIS function by replacing the corresponding amino acid residues with Ala and Pro. They observed that the hydroxyl groups of Ser353, Thr354, Ser356 and Thr357 seem to be essential for NIS activity, as NIS only functioned to a significant extent when these positions were occupied by Ser or Thr.

Eskandari *et al.*¹³ examined the mechanism, stoichiometry and specificity of NIS by means of electrophysiological, tracer uptake and electron microscopic methods in *X. laevis* oocytes expressing rNIS. Using the two microelectrode voltage clamp technique (Fig. 2a) and obtaining electrophysiological recordings, NIS activity was shown to be electrogenic; that is, an inward steady-state positive charge current was generated upon addition of I^- to the bathing medium (Fig. 2b). Simultaneous measurements of tracer fluxes and currents revealed that two Na^+ ions were transported with one anion, demonstrating unequivocally a $2\text{Na}^+ : 1\text{I}^-$ stoichiometry. In addition, on the basis of the obtained kinetic results, an ordered simultaneous transport mechanism was

previously been diagnosed with hypothyroidism caused by congenital ITD (Refs 23,24). Both groups found a nucleotide substitution in exon 9, resulting in a Pro instead of Thr at position 354 (T354P) in NIS. The T354P mutation is located in the putative transmembrane segment IX of the NIS protein (Fig. 1a). Levy *et al.*²⁵ studied the T354P mutation by site-directed mutagenesis and transfection of COS cells. This group determined that T354P NIS was not active but, as observed by immunofluorescence analysis, was properly targeted to the plasma membrane. Various other amino acid substitutions (Ala, Pro, Cys, Tyr, Ser) at position 354 were assessed to determine the structural requirements in putative transmembrane segment IX. This led to the conclusion that the hydroxyl group at the β -carbon of

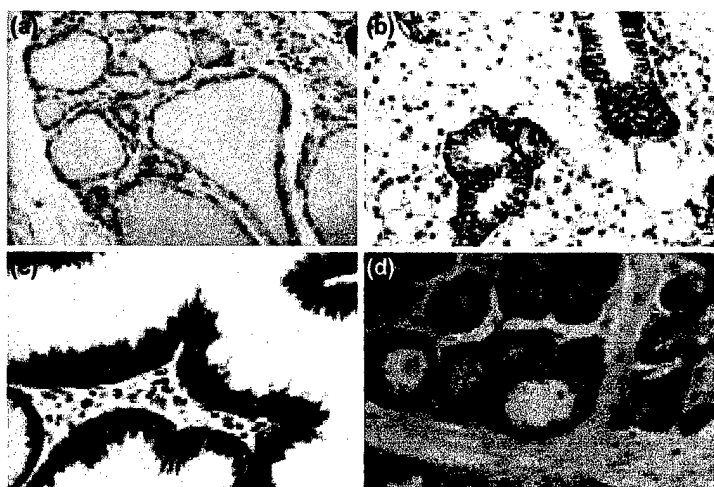

Fig. 3. Immunohistochemical analysis of NIS protein expression in tissues that exhibit active I^- transport: (a) thyroid, (b) salivary gland, (c) stomach and (d) lactating mammary gland. Panels (a), (b) and (d) are reproduced, with permission, from Ref. 6. The image shown in (c) was obtained using techniques described in Ref. 6.

proposed in which the two Na^+ ions bind to NIS before I^- binds to NIS (Fig. 2c)¹³.

Similar steady-state inward currents were generated by a wide variety of anions in addition to I^- (Fig. 2d), indicating that these anions are also transported by NIS. However, perchlorate (ClO_4^-), the most widely characterized inhibitor of thyroidal I^- uptake and an ion previously reported to be transported by NIS, did not generate a current, strongly suggesting that it is not transported¹³. Similarly, Yoshida *et al.*²⁷ have reported that perchlorate did not induce an inward current in Chinese hamster ovary (CHO) cells stably expressing NIS. The most likely interpretation of these observations is that perchlorate is not transported by NIS.

Physiological expression and regulation of NIS in different tissues

NIS was once believed to be a thyroid-specific protein. However, it is now clear that NIS is expressed in a variety of tissues (Fig. 3), in which NIS is regulated differently. Under physiological conditions, the thyroid, salivary glands and stomach exhibit constitutive I^- accumulation mediated by NIS. By contrast, NIS in the mammary gland is functionally expressed only during late pregnancy and lactation⁶.

The *hNIS*cDNAs cloned from gastric mucosa, parotid (salivary) and mammary glands⁵ are identical to that from thyroid tissue. Immunohistochemical analyses revealed positive NIS staining in the basolateral membrane of salivary ductal cells²⁸, mucin-secreting epithelial cells of the gastric mucosa^{6,29} and epithelial cells of the lactating breast⁶. The polarized basolateral localization of NIS in all these cells strongly resembled the

immunohistochemical NIS pattern observed in thyroid follicular cells³⁰. The *NIS* mRNA transcript has been detected using the reverse transcriptase–polymerase chain reaction (RT–PCR) in salivary glands, gastric mucosa, prostate, ovary, testis, pancreas, placenta, pituitary gland and thymus⁵. However, of these, only salivary glands and gastric mucosa have been found to exhibit Na^+ -dependent, perchlorate-sensitive, active I^- accumulation¹. Therefore, detection of the *NIS* mRNA by RT–PCR cannot be regarded as sufficient evidence of functional expression of NIS in the absence of a correlation with NIS activity.

Regulation of NIS protein expression in the thyroid

Thyroid I^- accumulation is stimulated by TSH, the primary hormonal regulator of all thyroid function. TSH is synthesized by the adenohypophysis and its release is stimulated by thyrotropin-releasing hormone (TRH) (derived from the hypothalamus) and inhibited through a negative-feedback mechanism by the thyroid hormones¹⁴. TSH stimulation of I^- accumulation results, at least in part, from the cAMP-mediated increased biosynthesis of NIS (Refs 15,31–33). NIS protein expression is upregulated by TSH *in vivo*³¹. The expression of *NIS* mRNA in dog thyroid is dramatically upregulated by blocking I^- organification with propyl-thiouracil (PTU) (Ref. 34), which mainly inhibits thyroid peroxidase. Although relatively little is known about the mechanisms by which TSH regulates NIS activity, posttranscriptional events have also been suggested to play a role^{35,36}. Interestingly, it has been observed that TSH induces *de novo* NIS biosynthesis and modulates the long NIS half-life, and that TSH is required for NIS targeting to, or retention in, the plasma membrane³⁷. It has also been shown that NIS is a phosphoprotein and that TSH modulates its phosphorylation pattern³⁷. The phosphopeptide map obtained when TSH was present was markedly different from that when TSH was absent: five phosphopeptides were resolved in the presence and three in the absence of TSH (Ref. 37).

Other than TSH, the main factor regulating NIS activity in the thyroid is I^- itself. Wolff and Chaikoff reported in 1948 that organic binding of I^- in rat thyroid was blocked when thyroid I^- reached a critical high threshold, a phenomenon known as the acute Wolff–Chaikoff effect³⁸. Approximately two days later, in the presence of continued high plasma I^- concentrations, an 'escape' (or adaptation) from the acute effect is observed, so that the level of I^- organification is restored and normal hormone biosynthesis resumes³⁹. The mechanism of the acute Wolff–Chaikoff effect has been suggested to be the result of organic iodocompounds acting as mediators⁴⁰. The less well-studied mechanism for the 'escape' was proposed to result from a decrease in I^- transport leading to sufficiently low intracellular

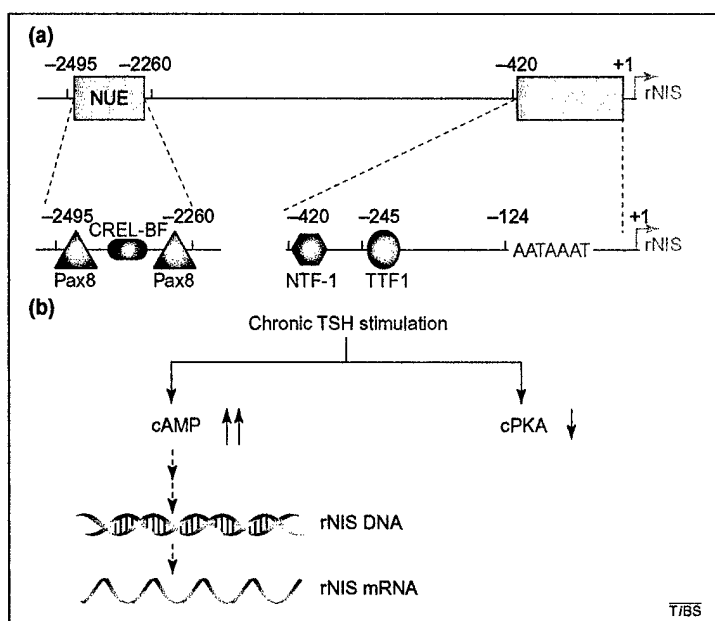

Fig. 4. NIS transcriptional regulation in rat thyroid cells. (a) Diagram of the *NIS* promoter indicating the major transcription start site (+1), the TATA box (AATAAAT) and the *NIS* upstream enhancer (NUE). The NUE contains two Pax8-binding sites and a degenerate CRE (cAMP responsive element) sequence, which are important for full thyroid stimulating hormone (TSH)-cAMP-dependent transcription. (b) Transcriptional regulation of the *NIS* gene in thyroid cells. During chronic TSH stimulation, cAMP activates *NIS* transcription³³ even when the catalytic subunit of PKA is downregulated⁴⁹.

I⁻ concentrations that removed the feedback inhibition of I⁻ organification⁴¹. *In vivo* studies have shown that low doses of I⁻ inhibit the expression of mRNAs encoding both TPO and NIS in dog thyroid³⁴. More recently, Eng *et al.*⁴² measured the levels of *NIS* mRNA and NIS protein in response to both chronic and acute I⁻ excess in rats *in vivo*. The results showed that the decrease of I⁻ transport observed during the 'escape' is a consequence of a decrease in NIS expression which, in turn, is mediated, at least in part, by a transcriptional mechanism.

Recent evidence strongly supports the notion that NIS activity depends on the state of polarization of the cell⁴³. TSH markedly stimulated *NIS* mRNA and protein levels in both monolayer and follicle-forming human primary culture thyrocytes, but significant stimulation of I⁻ uptake was observed only in follicles⁴³. These interesting observations indicate that, in addition to TSH stimulation, cell polarization and spatial organization are crucial for proper thyroid function. Among other factors that have been reported to modulate NIS expression are cytokines⁴⁴, estrogen⁴⁵ and Tg (Ref. 46).

Three different transcription factors have been implicated in thyroid-specific gene transcription: thyroid transcription factor (TTF) 1, TTF-2 and Pax8 (Ref. 47). As for rat *NIS*, Endo *et al.*⁴⁸ localized a TTF-1 binding site that confers thyroid-specific transcription but only exerts a modest effect. The

same group subsequently identified a novel TSH-responsive element (TRE) in the promoter region of *NIS* that modestly upregulates *NIS* expression⁴⁹. The TSH effect is cAMP-mediated and thyroid-specific. The protein that binds this site is not TTF-1, TTF-2, Pax8 or any other known transcription factor; this protein was named NTF-1 (NIS TSH-responsive factor 1)⁴⁹.

A thorough characterization of the upstream enhancer of the *rNIS* gene has been reported by Ohno *et al.*³³ The *rNIS* regulatory region contains a non thyroid-specific promoter and an enhancer that recapitulates the most relevant aspects of *NIS* regulation. The *NIS* upstream enhancer (NUE) stimulates transcription in a thyroid-specific and cAMP-dependent manner. NUE contains two Pax8 binding sites, two TTF-1 binding sites that have no effect on *rNIS* transcription and a degenerate CRE (cAMP responsive element) sequence, which is important for NUE transcriptional activity. In NUE, both Pax8 and the unidentified CRE-like binding factor (CRE-LBF) act synergistically to obtain full TSH-cAMP-dependent transcription. However, this enhancer is also able to mediate cAMP-dependent transcription by a novel PKA-independent mechanism³³ (Fig. 4). The transcriptional regulation of the *NIS* gene differs from that of true thyroid-restricted genes such as those encoding Tg and TPO.

Regulation of NIS protein expression in the mammary gland

Physiologically, I⁻ transport in the mammary gland occurs during late pregnancy and during the course of lactation. An adequate supply of I⁻ for sufficient thyroid hormone production is essential for proper development of the newborn's nervous system, skeletal muscle and lungs. Tazebay *et al.*⁶ demonstrated that I⁻ transport in the mammary gland is mediated by NIS. They showed that NIS was absent in nubile mammary glands from rats, but that NIS expression was increasingly detectable towards the end of gestation, and intensely apparent in lactating mammary gland. Interestingly, NIS expression was regulated in a reversible manner by suckling during lactation. *In vivo* studies in ovariectomized mice showed that the combination of β -estradiol, oxytocin and prolactin, in the absence of progesterone (i.e. the relative hormonal levels prevalent in mice during lactation), lead to the highest level of NIS expression⁶.

Pathophysiological impact of NIS

Impact of NIS on thyroid cancer

NIS activity plays a major diagnostic and therapeutic role in the management of differentiated thyroid carcinoma. On scintigraphy, most thyroid cancers exhibit decreased I⁻ uptake relative to the surrounding tissue. Conversely, sufficient I⁻ transport activity in thyroid cancer cells is required for ¹³¹I

radioablation therapy to be effective against remnant thyroid malignant cells or metastases after thyroidectomy¹⁷. Radioiodide ablation destroys occult microscopic carcinomas and also any remaining normal thyroid tissue, permitting postablative ¹³¹I total body scanning search for possible persistent carcinoma. Given the decrease in I⁻ uptake observed in most thyroid cancers, it had long been expected that NIS expression would be decreased in thyroid cancer cells. Moreover, several researchers have focused on finding ways to induce *NIS* transcription in thyroid cancer, thus seeking to improve the I⁻ transport ability of thyroid cancer cells and thereby the effectiveness of radioiodide therapy^{50,51}. However, several recent reports, using a variety of approaches, reveal a more complex picture. Surprisingly, some thyroid cancers overexpress NIS (Refs 52–54). The latest data suggest that the decrease observed in I⁻ uptake in differentiated thyroid cancer might result either from decreased expression of the *NIS* gene or from faulty targeting and/or insufficient retention of NIS in the plasma membrane. A more complete understanding of NIS regulation in healthy and cancerous thyroid could provide insights into possible improvements of radioiodide treatment strategies for thyroid carcinoma.

Impact of NIS on breast cancer

The ability of cancerous thyroid cells to actively transport I⁻ via NIS provides a unique and effective delivery system to detect and target these cells for destruction with therapeutic doses of radioiodide, largely without harming other tissues. Therefore, it seems feasible that radioiodide could be a diagnostic and therapeutic tool for the detection and destruction of other cancers in which NIS is functionally expressed. Pointing in this direction, a recent report by Tazebay *et al.*⁶ showed that both human breast carcinomas and experimental mammary carcinomas in transgenic mice express NIS. *In vivo* scintigraphic imaging of experimental mammary adenocarcinomas in non-gestational and non-lactating female transgenic mice, either carrying an activated *ras* oncogene or overexpressing the *neu* oncogene, demonstrated pronounced, active, specific and perchlorate-inhibitable NIS activity⁶. Hence, the authors concluded that transgenic mice bearing experimental mammary tumors provide an excellent model to study the potential role of NIS in mammary cancer, particularly with respect to the effectiveness of radioiodide therapy in combating this disease. Using immunohistochemistry, Tazebay *et al.*⁶ further showed that 87% of 23 human invasive breast cancers and 83% of six ductal carcinomas *in situ* expressed NIS, as compared to only 23% of

13 extratumoral samples from the vicinity of the tumors. Even more significantly, none of the eight normal samples from reductive mammoplasties they studied expressed NIS. These results suggest that radioiodide could represent a novel, potential alternative therapeutic modality in breast cancer.

NIS-based gene therapy

Several *in vitro* experiments concerning NIS-based gene therapy for both diagnostic and therapeutic purposes have been reported, in which NIS-mediated radioiodide uptake was used to visualize and destroy malignant tumor cells. *rNIS*-transduced tumor cells (melanoma, and ovarian, liver and colon carcinoma) exhibited I⁻ uptake activity⁵⁵. *In vitro* experiments showed that these transduced cells could be destroyed by accumulation of ¹³¹I. Tissue-specific, androgen-dependent I⁻ uptake activity has also been induced in prostate cancer cells *in vitro* by PSA (prostate specific antigen) promoter-directed *NIS* expression⁵⁶. In a different study, xenografts from a NIS-expressing human prostate cancer cell line established in nude mice were reported to actively accumulate as much as 25–30% of administered I⁻ *in vivo* (Ref. 57). Strikingly, the size of the xenograft tumors in these mice was significantly reduced after a single intraperitoneal injection of a therapeutic dose (3 mCi) of ¹³¹I (Ref. 57).

The gene therapy approach is undoubtedly one of the most promising developments concerning the possible uses of the molecular characterization of NIS in the diagnosis and treatment of cancer in a wide variety of tissues; however, a specific and efficient gene-delivery system has yet to be developed.

Concluding remarks

In just a few years, our conception of NIS has changed from a thyroid-specific protein, highly significant in the diagnosis and treatment of thyroid disease but unknown at the molecular level, to an extensively characterized transporter expressed beyond the thyroid. NIS has potentially far-reaching medical applications in breast cancer and cancer in other tissues. These applications, as well as additional valuable insights into the biochemistry of membrane transporters, might be achieved in the near future as progress continues in efforts to purify and functionally reconstitute NIS, elucidate NIS structure–function relations, and uncover the mechanisms involved in the differential regulation of NIS expression in various tissues*.

*After this review was submitted, an interesting article about the effects of thyroglobulin and pendrin on iodide flux was published⁵⁸.

Acknowledgements

C.R. was supported by the United States ARMY Medical Research and Materiel Command Office Award BC990754. This work was supported by the National Institutes of Health DK-41544 (N.C.).

References

- 1 Brown-Grant, K. (1961) Extra thyroidal iodide concentrating mechanisms. *Physiol. Rev.* 41, 189–213
- 2 www.ICCID.org
- 3 Delange, F. (1994) The disorders induced by iodine deficiency. *Thyroid* 4, 107–128
- 4 Dai, G. *et al.* (1996) Cloning and characterization of the thyroid iodide transporter. *Nature* 379, 458–460
- 5 Spitzweg, C. *et al.* (1998) Analysis of human sodium iodide symporter gene expression in extrathyroidal tissues and cloning of its complementary deoxyribonucleic acids from salivary gland, mammary gland, and gastric

- mucosa. *J. Clin. Endocrinol. Metab.* 83, 1746–1751
- 6 Tazebay, U.H. *et al.* (2000) The mammary gland iodide transporter is expressed during lactation and in breast cancer. *Nat. Med.* 6, 871–878
 - 7 Smanik, P.A. *et al.* (1996) Cloning of the human sodium iodide symporter. *Biochem. Biophys. Res. Commun.* 226, 339–345
 - 8 Bagchi, N. and Fawcett, D.M. (1973) Role of sodium ion in active transport of iodide by cultured thyroid cells. *Biochim. Biophys. Acta* 318, 235–251
 - 9 De la Vieja, A. *et al.* (2000) Molecular analysis of the sodium/iodide symporter: impact on thyroid and extrathyroid pathophysiology. *Physiol. Rev.* 80, 1083–1105
 - 10 Weiss, S.J. *et al.* (1984) Iodide transport in a continuous line of cultured cells from rat thyroid. *Endocrinology* 114, 1090–1098
 - 11 Carrasco, N. (1993) Iodide transport in the thyroid gland. *Biochim. Biophys. Acta* 1154, 65–82
 - 12 Nagataki, S. and Yokohyama, N. (1996) Other factors regulating thyroid function. Autoregulation: effects of iodide. In *The Thyroid* (Braverman, L.E. and Utiger, R.D., eds), pp. 241–247, Lippincott–Raven
 - 13 Eskandari, S. *et al.* (1997) Thyroid Na⁺/I⁻ symporter. Mechanism, stoichiometry, and specificity. *J. Biol. Chem.* 272, 27230–27238
 - 14 Vassart, C. and Dumont, J.E. (1992) The thyrotropin receptor and the regulation of thyrocyte function and growth. *Endocr. Rev.* 13, 596–611
 - 15 Weiss, S.J. *et al.* (1984) Thyrotropin-stimulated iodide transport mediated by adenosine 3',5'-monophosphate and dependent on protein synthesis. *Endocrinology* 114, 1099–1107
 - 16 Taurog, A.M. (2000) Thyroid hormone synthesis. In *The Thyroid: a Fundamental and Clinical Text* (Braverman, L.E. and Utiger, R.D., eds), pp. 75–79, Lippincott–Raven
 - 17 Mazzaferri, E.L. (2000) Carcinoma of the follicular epithelium. In *The Thyroid: a Fundamental and Clinical Text* (Braverman, L.E. and Utiger, R.D., eds), pp. 904–930, Lippincott–Raven
 - 18 Levy, O. *et al.* (1998) N-linked glycosylation of the thyroid Na⁺/I⁻ symporter (NIS). Implications for its secondary structure model. *J. Biol. Chem.* 273, 22657–22663
 - 19 De la Vieja, A. *et al.* (2000) Topology of the sodium/iodide symporter. *Endocr. J.* 47 (Suppl.), 162
 - 20 Smanik, P.A. *et al.* (1997) Expression, exon–intron organization, and chromosome mapping of the human sodium iodide symporter. *Endocrinology* 138, 3555–3558
 - 21 Turk, E. and Wright, E.M. (1997) Membrane topology motifs in the SGLT cotransporter family. *J. Membr. Biol.* 159, 1–20
 - 22 Wolff, J. (1983) Congenital goiter with defective iodide transport. *Endocr. Rev.* 4, 240–254
 - 23 Fujiwara, H. *et al.* (1997) Congenital hypothyroidism caused by a mutation in the Na⁺/I⁻ symporter. *Nat. Genet.* 17, 122
 - 24 Matsuda, A. and Kosugi, S. (1997) A homozygous missense mutation of the sodium/iodide symporter gene causing iodide transport defect. *J. Clin. Endocrinol. Metab.* 82, 3966–3971
 - 25 Levy, O. *et al.* (1998) Identification of a structural requirement for thyroid Na⁺/I⁻ symporter (NIS) function from analysis of a mutation that causes human congenital hypothyroidism. *FEBS Lett.* 429, 36–40
 - 26 De la Vieja, A. *et al.* (2000) Several hydroxyl-containing amino acid residues in transmembrane segment IX are important for sodium/iodide symport activity. *Endocr. J.* 47 (Suppl.), 162
 - 27 Yoshida, A. *et al.* (1997) Different electrophysiological character of I⁻, ClO₄⁻, and SCN⁻ in the transport by Na⁺/I⁻ symporter. *Biochem. Biophys. Res. Commun.* 231, 731–734
 - 28 Jhiang, S.M. *et al.* (1998) An immunohistochemical study of Na⁺/I⁻ symporter in human thyroid tissues and salivary gland tissues. *Endocrinology* 139, 4416–4419
 - 29 Vayre, L. *et al.* (1999) Immunohistochemical analysis of Na⁺/I⁻ symporter distribution in human extra-thyroidal tissues. *Eur. J. Endocrinol.* 141, 382–386
 - 30 Caillou, B. *et al.* (1998) Na⁺/I⁻ symporter distribution in human thyroid tissues: an immunohistochemical study. *J. Clin. Endocrinol. Metab.* 83, 4102–4106
 - 31 Levy, O. *et al.* (1997) Characterization of the thyroid Na⁺/I⁻ symporter with an anti-COOH terminus antibody. *Proc. Natl. Acad. Sci. U. S. A.* 94, 5568–5573
 - 32 Kogai, T. *et al.* (1997) Regulation by thyroid-stimulating hormone of sodium/iodide symporter gene expression and protein levels in FRTL-5 cells. *Endocrinology* 138, 2227–2232
 - 33 Ohno, M. *et al.* (1999) The paired-domain transcription factor Pax8 binds to the upstream enhancer of the rat sodium/iodide symporter gene and participates in both thyroid-specific and cyclic-AMP-dependent transcription. *Mol. Cell. Biol.* 19, 2051–2060
 - 34 Uyttersprot, N. *et al.* (1997) Moderate doses of iodide *in vivo* inhibit cell proliferation and the expression of thyroperoxidase and Na⁺/I⁻ symporter mRNAs in dog thyroid. *Mol. Cell. Endocrinol.* 131, 195–203
 - 35 Kaminsky, S.M. *et al.* (1994) Na⁺-I⁻ symport activity is present in membrane vesicles from thyrotropin-deprived non-I⁻ transporting cultured thyroid cells. *Proc. Natl. Acad. Sci. U. S. A.* 91, 3789–3793
 - 36 Paire, A. *et al.* (1997) Characterization of the rat thyroid iodide transporter using anti-peptide antibodies. Relationship between its expression and activity. *J. Biol. Chem.* 272, 18245–18249
 - 37 Riedel, C. *et al.* (2001) Post-transcriptional regulation of the sodium/iodide symporter (NIS) by thyrotropin. *J. Biol. Chem.* 276, 21458–21463
 - 38 Wolff, J. and Chaikoff, I.L. (1948) Plasma inorganic iodide as a homeostatic regulator of thyroid function. *J. Biol. Chem.* 174, 555–560
 - 39 Wolff, J. *et al.* (1949) The temporary nature of the inhibitory action of excess iodide on organic synthesis in the normal thyroid. *Endocrinology* 45, 504–513
 - 40 Dugrillon, A. (1996) Iodolactones and iodoaldehydes: mediators of iodine in thyroid autoregulation. *Exp. Clin. Endocrinol. Diabetes* 104 (Suppl. 4), 41–45
 - 41 Braverman, L.E. and Ingbar, S.H. (1963) Changes in thyroidal function during adaptation to large doses of iodide. *J. Clin. Invest.* 42, 1216–1231
 - 42 Eng, P.H. *et al.* (1999) Escape from the acute Wolff-Chaikoff effect is associated with a decrease in thyroid sodium/iodide symporter messenger ribonucleic acid and protein. *Endocrinology* 140, 3404–3410
 - 43 Kogai, T. *et al.* (2000) Induction of follicle formation in long-term cultured normal human thyroid cells treated with thyrotropin stimulates iodide uptake but not sodium/iodide symporter messenger RNA and protein expression. *J. Endocrinol.* 167, 125–135
 - 44 Ajjan, R.A. *et al.* (1998) The sodium iodide symporter gene and its regulation by cytokines found in autoimmunity. *J. Endocrinol.* 158, 351–358
 - 45 Furlanetto, T.W. *et al.* (1999) Estradiol increases proliferation and down-regulates the sodium/iodide symporter gene in FRTL-5 cells. *Endocrinology* 140, 5705–5711
 - 46 Suzuki, K. *et al.* (1999) Follicular thyroglobulin suppresses iodide uptake by suppressing expression of the sodium/iodide symporter gene. *Endocrinology* 140, 5422–5430
 - 47 Missero, C. *et al.* (1998) Molecular events involved in differentiation of thyroid follicular cells. *Mol. Cell. Endocrinol.* 140, 37–43
 - 48 Endo, T. *et al.* (1997) Thyroid transcription factor-1 activates the promoter activity of rat thyroid Na⁺/I⁻ symporter gene. *Mol. Endocrinol.* 11, 1747–1755
 - 49 Ohmori, M. *et al.* (1998) A novel thyroid transcription factor is essential for thyrotropin-induced up-regulation of Na⁺/I⁻ symporter gene expression. *Mol. Endocrinol.* 12, 727–736
 - 50 Venkataraman, G.M. *et al.* (1999) Restoration of iodide uptake in dedifferentiated thyroid carcinoma: relationship to human Na⁺/I⁻ symporter gene methylation status. *J. Clin. Endocrinol. Metab.* 84, 2449–2457
 - 51 Schmutzler, C. and Kohrle, J. (2000) Retinoic acid redifferentiation therapy for thyroid cancer. *Thyroid* 10, 393–406
 - 52 Saito, T. *et al.* (1998) Increased expression of the sodium/iodide symporter in papillary thyroid carcinomas. *J. Clin. Invest.* 101, 1296–1300
 - 53 Arturi, F. *et al.* Sodium–iodide symporter (NIS) gene expression in lymph-node metastases of papillary thyroid carcinomas. *Eur. J. Endocrinol.* 143, 623–627
 - 54 Dohán, O. *et al.* (2001) Predominant intracellular overexpression of the Na⁺/I⁻ symporter (NIS) in a large sampling of thyroid cancer cases. *J. Clin. Endocrinol. Metab.* 86, 2697–2700
 - 55 Mandell, R.B. *et al.* (1999) Radioisotope concentrator gene therapy using the sodium/iodide symporter gene. *Cancer Res.* 59, 661–668
 - 56 Spitzweg, C. *et al.* (1999) Prostate-specific antigen (PSA) promoter-driven androgen-inducible expression of sodium iodide symporter in prostate cancer cell lines. *Cancer Res.* 59, 2136–2141
 - 57 Spitzweg, C. *et al.* (2000) Treatment of prostate cancer by radioiodine therapy after tissue-specific expression of the sodium iodide symporter. *Cancer Res.* 60, 6526–6530
 - 58 Kohn, L.D. *et al.* (2001) Effects on thyroglobulin and pendrin on iodide flux through the thyrocyte. *Trends Endocrinol. Metab.* 12, 10–16
 - 59 Armstrong, R. *et al.* (1995) A refractory phase in cyclic AMP-responsive transcription requires down regulation of protein kinase A. *Mol. Cell. Biol.* 15, 1826–1832