

DMIC

NASA (TECHNICAL NOTE)

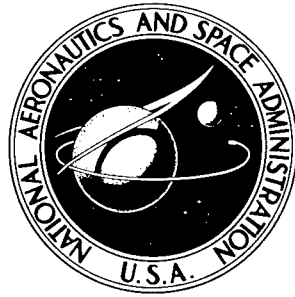

(NASA TN D-1917)

NASA TN D-1917

AMPTIAC

DISTRIBUTION STATEMENT A  
Approved for Public Release  
Distribution Unlimited

*Microfilm  
26 APR 62*

PROBLEMS IN THE CONSTRUCTION  
OF A SPACE ENVIRONMENT SIMULATOR

by Dana<sup>①</sup> S. Cope

Goddard Space Flight Center  
Greenbelt, Maryland

20020328 124

PROBLEMS IN THE CONSTRUCTION OF  
A SPACE ENVIRONMENT SIMULATOR

By Dana S. Cope

Goddard Space Flight Center  
Greenbelt, Maryland

NATIONAL AERONAUTICS AND SPACE ADMINISTRATION

---

For sale by the Office of Technical Services, Department of Commerce,  
Washington, D.C. 20230 -- Price \$0.50

# PROBLEMS IN THE CONSTRUCTION OF A SPACE ENVIRONMENT SIMULATOR

by

Dana S. Cope

*Goddard Space Flight Center*

## SUMMARY

Goddard Space Flight Center is constructing a space environment simulator which has advanced the state of the art of environment simulation. Problems concerning the material and construction of reflectors are presented in some detail. At present this facility provides oil-diffusion, cryogenic pumping, and controlled wall temperatures. Solar hardware fabrication is in the process of completion.

## CONTENTS

Summary . . . . .	i
INTRODUCTION . . . . .	1
REQUIREMENTS . . . . .	1
THE CHAMBER . . . . .	1
The Vacuum System . . . . .	4
Wall Temperature Control . . . . .	5
Cryogenics . . . . .	6
The Solar Simulator . . . . .	7
Mechanical Tolerances . . . . .	8
REFLECTORS AND LENSES . . . . .	9
The Ellipse . . . . .	9
The Hyperbola and Parabola . . . . .	10
The Lenses . . . . .	10
ASSEMBLY OF PROTOTYPE COMPONENTS . . . . .	10
Alignment . . . . .	10
Mounting Hardware . . . . .	10
Internal Reflector Cooling . . . . .	11
Vacuum Seals . . . . .	11
Relay Lens Protection . . . . .	11

# PROBLEMS IN THE CONSTRUCTION OF A SPACE ENVIRONMENT SIMULATOR

by

Dana S. Cope

*Goddard Space Flight Center*

## INTRODUCTION

When it is determined to build a new facility extending the state-of-the-art, many decisions must be made on the basis of the best information available tempered with human judgement. As the design and construction develop, many problems arise which are more difficult to solve than was first anticipated, as well as some thought to be important which solve themselves. When this occurs the facility has often progressed to the point where it is difficult or impossible to back up or start over. Therefore compromises must be made as best seen from the new position.

This presentation is a discussion of how some of these problems were met in the construction of a space environment simulator recently put in operation at Goddard Space Flight Center (Figures 1 and 2). At present the facility provides oil diffusion and cryogenic pumping and controlled wall temperatures but not solar simulation. Solar hardware fabrication has not yet been completed.

## REQUIREMENTS

1. Size—a work space 27-1/2 ft. in diameter × 40 ft. in height
2. Pressure—an ultimate pressure with full solar simulation of  $1 \times 10^{-8}$  torr in 24 hr
3. Shroud temperatures— $100^{\circ}\text{K}$  and  $-65^{\circ}$  to  $+100^{\circ}\text{C}$
4. Solar simulation—an intensity of 50 to 275 watts/ft.<sup>2</sup> and a uniformity of  $\pm 10$  percent over any square foot
5. Collimation—a  $\pm 4$  degree half angle
6. Spectral Distribution—equivalent to zero air mass solar radiation from 0.3 to 4.0 microns
7. Area covered—a 20 ft. diameter circle.

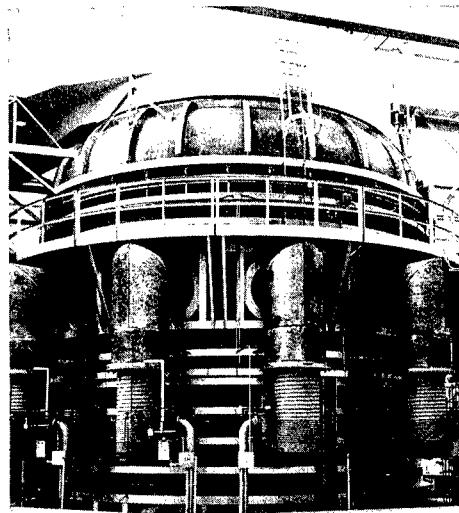

Figure 1—Space environment simulator.

## THE CHAMBER

The chamber walls are constructed of 304 stainless steel with No. 4 mill finish to keep outgassing to a minimum. Stainless steel was chosen rather than stainless clad steel to avoid

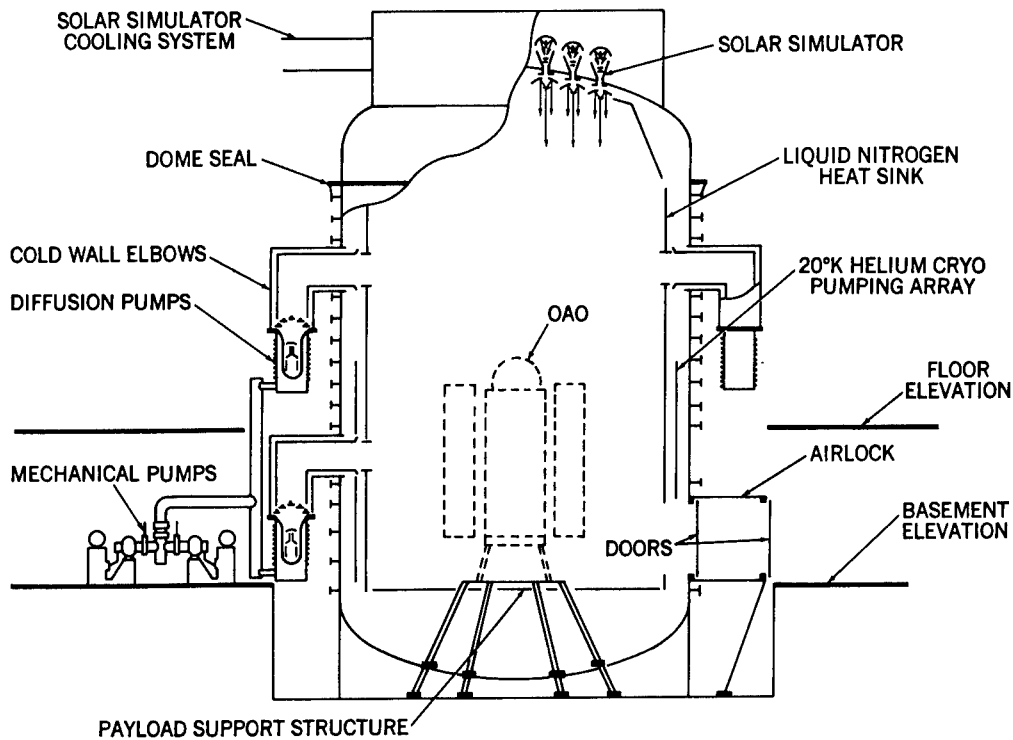

Figure 2—Cross-section of the simulator.

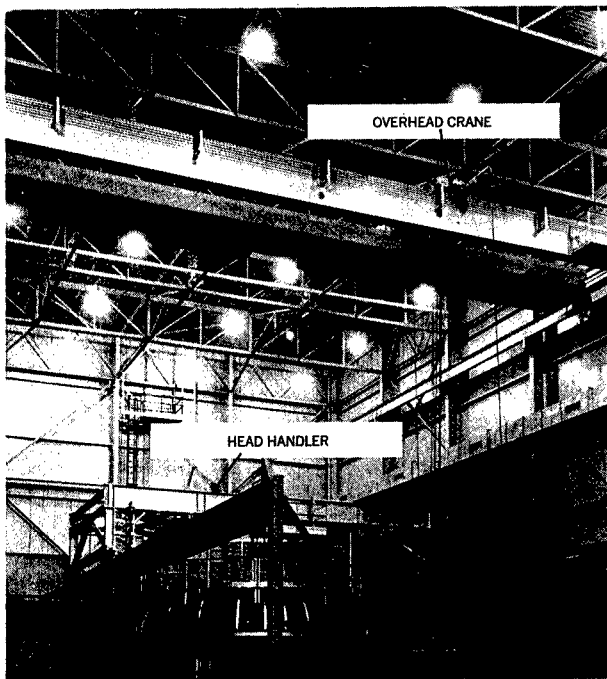

Figure 3—Head handler and overhead crane.

(both the possible welding problems and the effect of  $LN_2$  spillage and still maintain the desired interior finish. The chamber is externally reinforced with carbon steel. All welds except penetrations are full penetration welds and have been radiographed to insure against porosity within the weld. We now believe that all welds should be full penetration multi-pass welds.) *end*

The head is removable to provide access to the tank for placement of the test loads (Figure 3). This is accomplished by means of a specially designed head handler (Figure 4) that lifts the head 12 in. and then moves it horizontally on its own rails a distance of 40 ft. The spacecraft to be tested is placed in the vessel by means of a 15 ton overhead bridge crane. An air lock (Figure 5) installed at the payload table level provides access to the

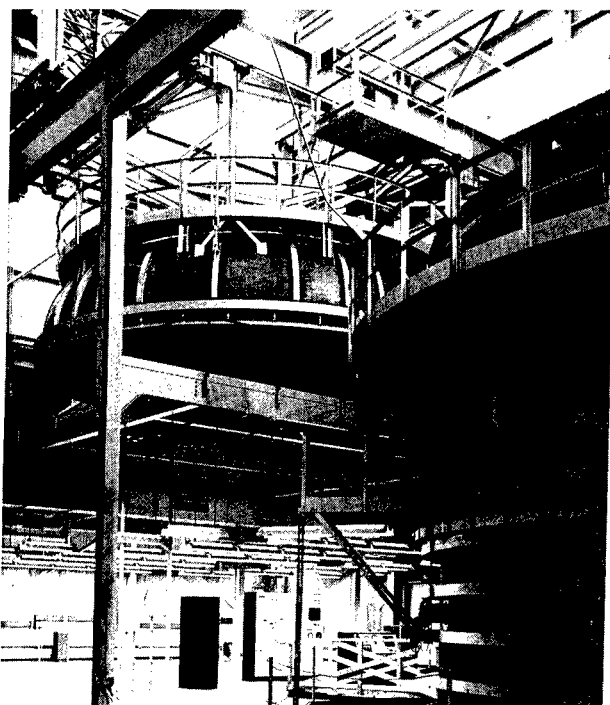

Figure 4—Head handler removed from the chamber.

normal working level so that a man in a space suit can enter to make repairs to a satellite and save an expensive test. The chamber has not as yet been man-rated.

The head is supported on flanges welded to the shell and head (Figure 6). Thin plates of stainless steel are welded to these flanges and to the seal flanges to give flexibility for sealing. This avoids all the problems of main vessel distortion with temperature or time. The lower seal flange is rigidly supported at 36 equally spaced points and the upper flange is adjusted in relation to it by means of jacks placed at the corresponding 36 points. The seal between these flanges consists of pumped double 3/8 in. Buna N "o" rings. The head seal has worked out very well and has caused no leak problem. All penetrations over 12 in. also have pumped double "o" rings. The seals for the solar penetrations will be discussed later.

A removable floor is used for protection of the bottom heat sink when personnel are working

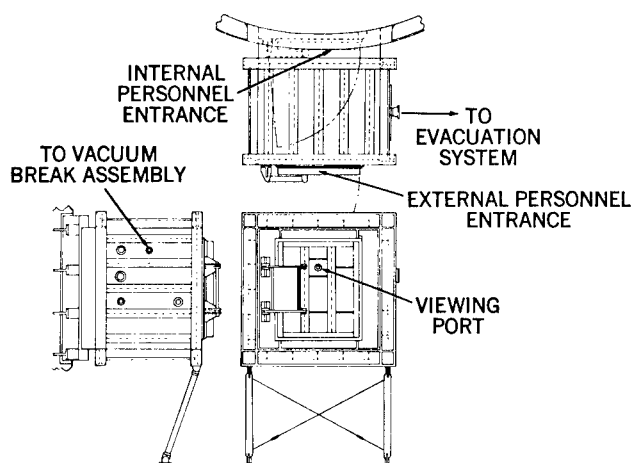

Figure 5—Details of the air lock.

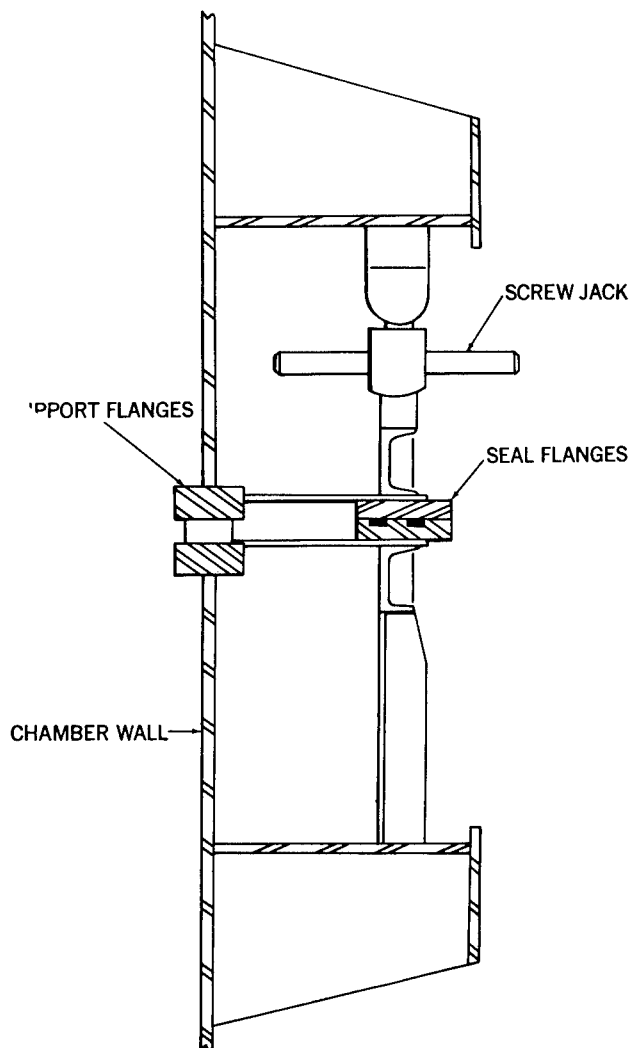

Figure 6—Head seal section.

inside the chamber. This consists of pie-shaped lightweight aluminum sections covered with checkered plate. Hard points have been located around the walls and in the dome to support any expected test load.

Leak testing of the chamber took approximately 6 weeks rather than the 2 weeks originally scheduled. The most important lesson learned was that on a tank this large it is impractical to try on the first attempt to pump to a low enough pressure to use the mass spectrometer. A complete and thorough subsystem and component leak check should be made. The final leak rate was  $2.5 \times 10^{-5}$  atm.-cc/sec.

Only one major change in design would be suggested for another chamber of comparable size. The inner door seal is not dependable when the air lock is evacuated (which leaves essentially the same pressure on both sides). This is true even though this door (Figure 7) is secured with ten clamping bolts. Since this clamping arrangement also makes the operation of the door slow, a better design should be found.

It is interesting to note that there were very few leaks in the field welds but most of the shop welds had to be redone.

## The Vacuum System

The design of the vacuum system, as originally designed is based on the following equipment, installed as shown schematically in Figure 8:

1. Twenty-five  $LN_2$  cooled elbows. These will eliminate any possibility of a heat load on the test object because of their optical density.
2. Twenty-five 32 in. diffusion pumps rated at 50,000 liters/sec each. These pumps are so designed that heating elements and pump oil can be changed while the system is under vacuum.
3. Twenty-five concentric disc water-cooled baffles between the  $LN_2$  cooled elbows and the diffusion pumps to prevent gross backstreaming.

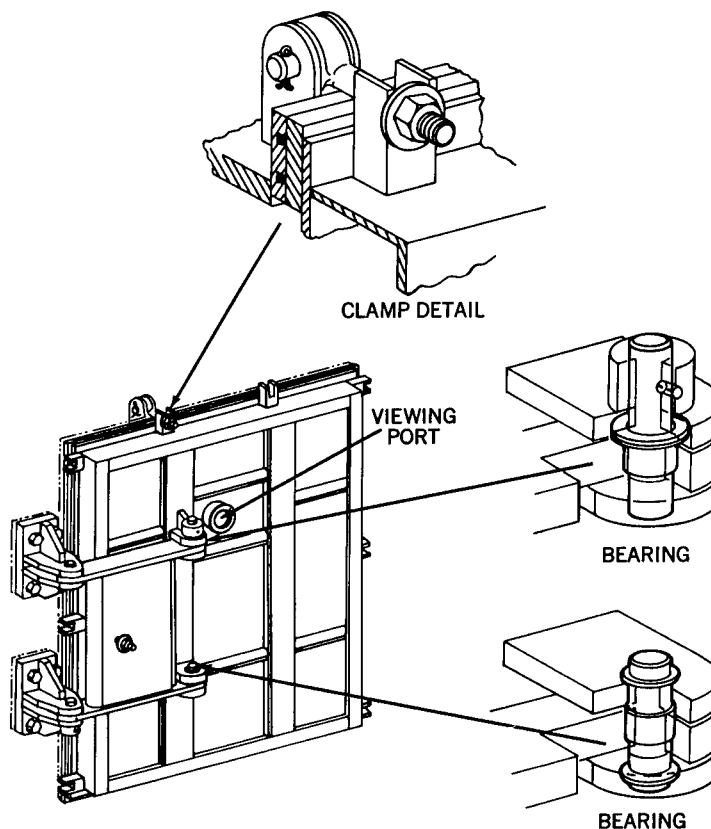

Figure 7—Air lock door.

4. Twenty-five 6 in. pneumatically operated poppet valves in the forearms of the diffusion pumps.
5. Six 10 in. water-cooled optically dense baffles installed between the diffusion and roughing pumps.
6. Twelve roughing vacuum pump units each consisting of a blower and mechanical high-vacuum pump.
7. Twelve 8 in. pneumatically operated gate valves to isolate each of the twelve roughing vacuum pump units.

In the early design phase it became necessary to economize and this was done by eliminating eight diffusion pumps and four vacuum pump units and the associated  $\text{LN}_2$  elbows, water baffles, and valves. Provision was made for adding this equipment at a later date.

The original design was based on reaching  $1 \times 10^{-8}$  torr in 24 hr. when used with the  $\text{LN}_2$  heat sinks and the GHe cold wall. With the elimination of these pumps, the design specification was changed to  $5 \times 10^{-8}$  in 48 hours.

This system has been installed with no troubles other than those normally found on jobs of this size. However, a complete leak check of all components is considered extremely valuable in the performance of the overall leak check of the chamber.

Since placing the chamber in operation several pump down tests have been run and much lower pressures have been reached in much less time than specified. As the pump down curve (Figure 9) shows a pressure of  $9.6 \times 10^{-10}$  torr was reached in 14 hr. This compares with the requirements of  $5 \times 10^{-8}$  torr in 48 hr. as called for in the specifications.

### Wall Temperature Control

To simulate outer space it is necessary to cover all walls, floor, and top with a cold wall at  $<100^\circ\text{K}$ . This temperature will give the equivalent of a 1 percent return of energy radiated by the satellite

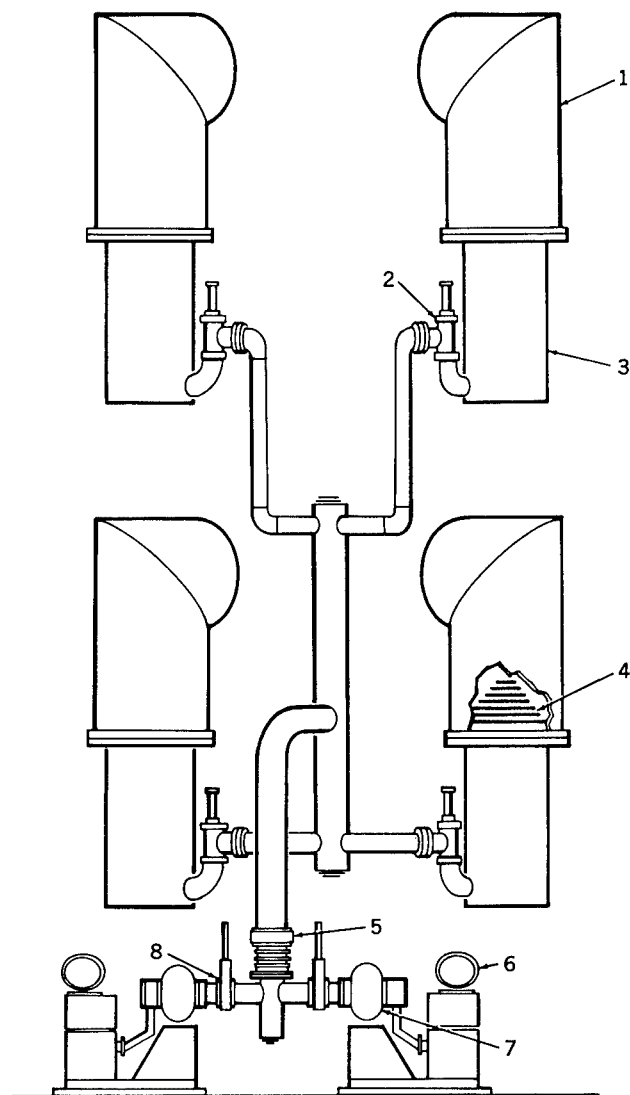

Figure 8—Vacuum pumping system schematic: (1)  $\text{LN}_2$  cooled elbow; (2) 6 in. air operated poppet valve; (3) Model PMC 50,000 diffusion pump; (4) Concentric disc water cooled baffle; (5) 10 in. water cooled baffle; (6) Model 412H vacuum pump; (7) Model 615 roots blower; (8) 8 in. air-operated gate valve.

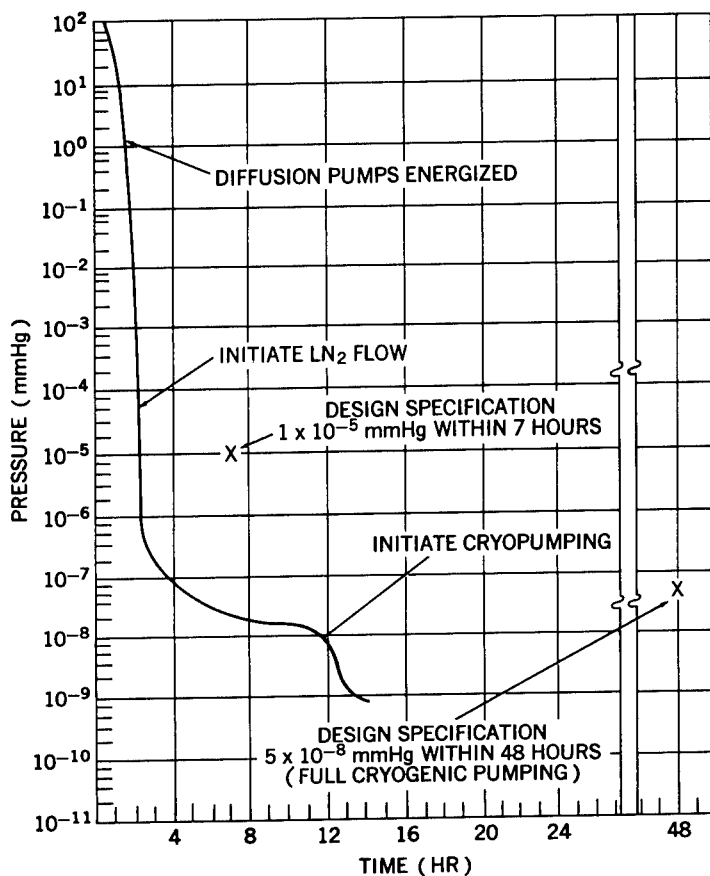

Figure 9—Pump down curve.

When the temperature is to be controlled between  $-65^{\circ}$  and  $+100^{\circ}\text{C}$ , gaseous nitrogen is circulated through the system and either cooled with a 3 stage Freon 22 system or heated with steam, as conditions require.

LN<sub>2</sub> for the operation of the cold wall is stored adjacent to the building in a vacuum insulated ball holding 64,000 gallons.

These cold walls have been installed with very few leaks and the entire system commenced operation without excessive trouble.

### Cryogenics

The cryopumping is accomplished with a 1 kilowatt capacity gaseous helium refrigeration unit circulating through helium panels. These are placed in the lower half of the chamber behind baffles projecting from the LN<sub>2</sub> cold wall at 45 degrees (frequently called Santeller array). This protects the helium panels from any heat load while utilizing their capacity to condense those vapors that will not condense the LN<sub>2</sub> cold wall but will at 20°K. The helium panels are supplied with gaseous helium at 15°K to maintain a maximum temperature of 20°K.

The upper half of the LN<sub>2</sub> cold wall is provided with shields so that helium panels can be installed in this portion of the chamber at a later date.

under test. The cold wall was constructed using tube-in-sheet aluminum panels assembled to cover as completely as possible side walls, bottom, and top, except for the area used for the solar simulator which has a separate LN<sub>2</sub> cooling system. The LN<sub>2</sub> panels were mounted 30 in. inside the chamber, at the sacrifice of working space, to make it possible for a man to get behind them for repair of leaks. This has proved very beneficial. The aluminum panels are painted with black epoxy paint on the inner surface for maximum absorptivity and are bright on the back side for maximum reflectivity to minimize heat absorption from the external vessel wall.

Cooling to  $<100^{\circ}\text{K}$  is accomplished by means of LN<sub>2</sub> pumped under sufficient pressure to remain liquid at all times. It is cooled outside the chamber in a subcooler using evaporating LN<sub>2</sub> at atmospheric pressure for refrigeration. The panels are manifolded in a way which assures a uniform pressure drop in each circuit.

## The Solar Simulator

The problems in building the solar simulator were more severe than those in any other part of this project. This is because the state-of-the-art was extended further than in the other portions of the job and also because of production problems.

After much consideration of the state of the art of solar simulation, it was decided to set the following specifications:

1. Intensity—50 \ watts/ft.<sup>2</sup> to 275 watts/ft.<sup>2</sup>
2. Uniformity—±10 percent over any square foot.
3. Collimation—±4 degree half angle.
4. Spectral Distribution—Equivalent to zero air mass solar radiation from 0.3 to 4.0 microns.
5. Area Covered—20 ft. diameter circle.

After a review of all available information, an on-axis system proposed by Minneapolis-Honeywell consisting of multiple-modules, each self-contained, was selected. The design selected is based on using 127 modules placed in a hexagon of 20 in. centers (Figure 10). Together these will cover a circle 20 ft. in diameter. Because of the collimation angle there is some overlap between modules. Therefore, the intensity will drop somewhat at the edges, starting to fall off outside a 17 ft. diameter circle. This decision was based on these considerations:

### *Advantages*

1. Lower initial cost.
2. Smaller optics.
3. Smaller penetrations.
4. Uses 2 1/2 kw lamps for earth orbit intensity.
5. Possible to use partial system for limited area.
6. Can be proven by building and testing one module.
7. Better efficiency.

### *Disadvantages*

1. Burned out lamp causes dark area.
2. Many penetrations.
3. Does not preclude re-reflection (re-reflection will not exceed 2 to 3 percent with the multiple modules).

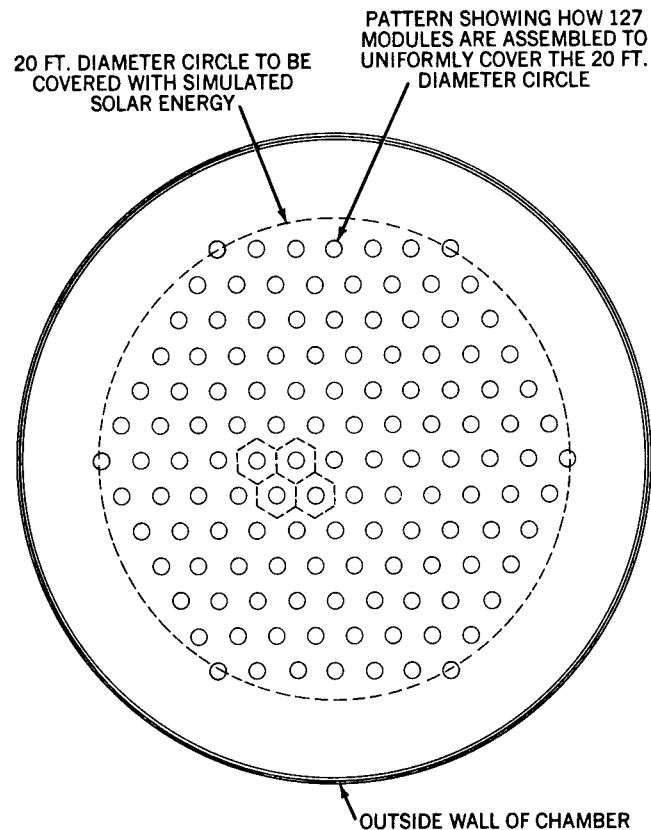

Figure 10—Solar module arrangement.

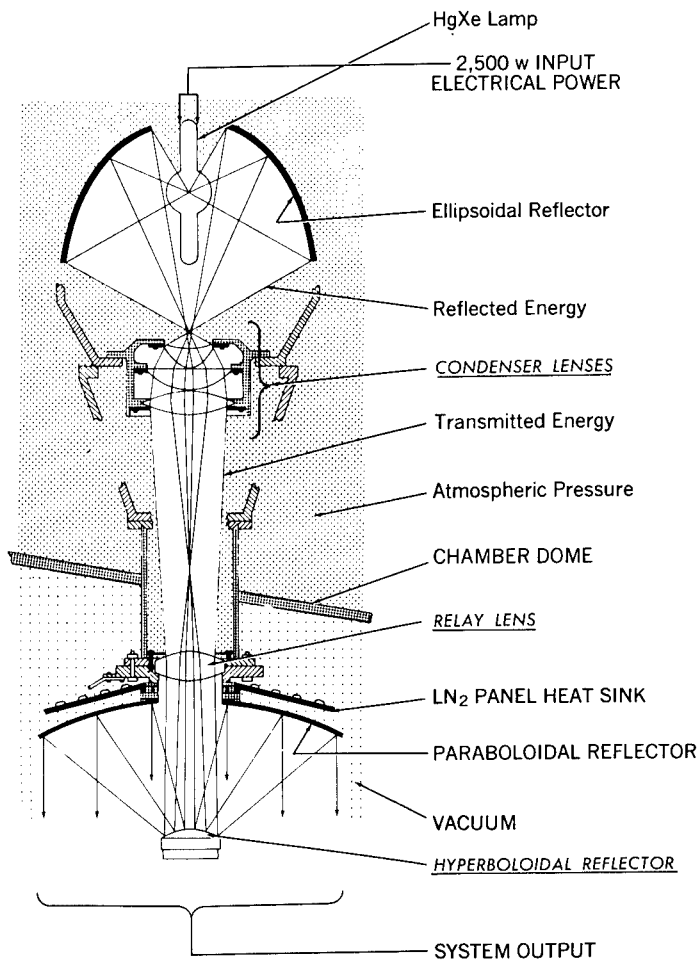

Figure 11—Solar Simulator Module Schematic.

Each module is identical to all the others and consists of (Figure 11):

1. The light source (presently planned as a 2500 watt mercury-xenon short arc lamp, with power supplies and holding fixtures designed so that later a 5000 watt lamp can be used).
2. Elliptical reflector to collect the energy.
3. Three condenser lenses.
4. Relay lens.
5. Hyperboloidal reflector.
6. Paraboloidal reflector.

An overall efficiency from lamp input to energy delivered on the test floor of approximately 12-1/2 percent is required to make the system produce the desired intensity of 130 w/ft.<sup>2</sup> using the 2-1/2 kw lamp. The requirement for this degree of energy transfer efficiency in the system is the basic cause of the extreme fabrication accuracies required, as discussed below. The basic design of the system has changed very little since the original conception, but there has been much detail refinement and many concurrent troubles.

It was necessary to settle on detailed design of the lenses early because of the urgency to complete the facility. Once this lens grinding was started, it limited design conditions on other elements of the system.

## Mechanical Tolerances

While the lenses were being ground, it became apparent that a detailed tolerance analysis was essential for firm mechanical design and alignment requirements. Therefore a study was instituted and 150 hrs of IBM 7090 computer time were utilized to determine the effect on the system of movements of each of the elements relative to others and of incremental inaccuracies of each. As a result it was determined that the lamp and ellipsoidal reflector must be located within  $\pm 0.010$  inches with

reference to each other and that the parabolic reflector with reference to the hyperbolic reflector must be held within 0.010 inches of the hyperbolic reflector. The other elements did not have critical tolerances and would be satisfactory if held within 0.050 inches. The surface of the elliptical reflector must have a slope accuracy of 5 minutes.

It also became apparent that a new process would have to be developed for making elliptical reflectors in a manner suitable for quantity (127) production. Therefore it was decided to halt all hardware production until a module could be built and tested using all final design optical elements. These would all be made by the proposed production techniques. This would also verify the computer study and give much more assurance of final success.

## REFLECTORS AND LENSES

### The Ellipse

The elliptical reflector was unusually deep. So far as could be determined a reflector of this contour had never been produced with the required accuracy. Since 127 of them were required, it was decided that a process which reproduced reflectors from a very accurate master would have to be employed.

First, difficulty was encountered in obtaining a glass master made to acceptable accuracies. Even getting a glass blank of the right shape proved difficult. An attempt was made to get pyrex type glass slumped to the approximate contour and then annealed. This proved to be a very slow process and in order to save several weeks annealing time, we agreed to only a rough anneal before grinding the master. This later proved to be a mistake as several masters were lost by a very gentle thermal shock at temperatures no higher than 140 °F.

Later several optical shops were contacted for a second try at grinding the master. None would commit themselves to less than three months time for production. This turned out to be optimistic since delivery took more than five months.

In the meantime, we investigated other methods, one of which was making the master in metal on a tape controlled machine. This process is fast and apparently accurate. However, since this is not done in an optical shop, there is the added problem that mechanical tolerances are not easily translatable into optical tolerances. A master produced by this process does meet (according to initial tests) the optical tolerance requirements. Recently we learned of an optical shop with a new method of grinding glass rapidly and accurately using a diamond grinding process and have procured a master by this process and delivery was less than two months with accuracy much better than those previously produced.

After getting a master it was necessary to replicate the reflector. The first attempt was an ellipse made of cast epoxy which failed to hold its shape. Electroforming has shown considerable promise of success. To date we have been most successful with a thin film epoxy replication. For this an aluminum casting is machined approximately 0.030" oversize and a thin film of epoxy is

forced between the aluminum and the master. It is hoped that the thin epoxy film will hold its accurate contour under the severe heating and cooling of the operational cycle: however, tests of up to 200 hours reveal no deterioration.

### **The Hyperbola and Parabola**

The hyperboloidal reflector being made from quartz has presented no manufacturing problems: however, there have been temperature difficulties. The first design was for rigid contact with the LN<sub>2</sub> cooling coil and this created too much shock for quartz which fractured on each test. A new design using flexible copper leads to carry the heat to the LN<sub>2</sub> was used. This does not cause fracturing: however, heat destroyed the reflective coating. Latest tests indicate that this can be overcome by applying the proper emissive coatings on the back side of the reflector to assist in removing the heat by radiation to the cannister. As insurance an electroform hyperbola is being made and will be tested for heat transfer and satisfactory optical properties throughout the temperature range.

Electroforming has been used satisfactorily to make the paraboloidal reflector, although there was some early experience with lack of accuracy at the edges.

### **The Lenses**

The lenses have presented no major problem once the allowable tolerances were determined. They are now being produced by Goddard Space Flight Center.

## **ASSEMBLY OF PROTOTYPE MODEL**

### **Alignment**

Fixtures have been designed to check and align each of the elements of the module within the tolerances required. It is believed that these will give satisfactory results when carefully used. To facilitate lamp replacement, one fixture will align the lamp to a predetermined surface. Thus the assembly can be replaced so that the arc of the new lamp will be in the same location as the replaced lamp.

### **Mounting Hardware**

When the manufactured prototype components were completed, a module was assembled and properly aligned for test. The first tests indicated the temperature rise in the mounting hardware was causing excessive growth and not allowing the optical elements to hold their position within allowable tolerances. This was corrected by increasing the reflectivity of the hardware with aluminum paint; and thereby decreasing the heat being absorbed and in turn its thermal growth.

## Internal Reflector Cooling

LN<sub>2</sub> heat sinks have been designed behind each of the paraboloidal, as well as the hyperboloidal, reflectors to remove the heat absorbed by these elements.

## Vacuum Seals

The vacuum seals from the relay lens to its flange and from the flange to the vessel have caused difficulties. The former is of viton and the latter was to be crushed aluminum. Temperature readings on these surfaces indicated probable trouble because of the broad temperature range (from maximum heat with the continuously-running solar simulator to the cold experienced with the LN<sub>2</sub> cooling when the solar simulator is not operating). Latest tests indicate that relocation of the LN<sub>2</sub> cooling unit and the use of viton seals throughout will probably correct this.

## Relay Lens Protection

The temperature of the relay lens becomes low enough while the parabola is being cooled with LN<sub>2</sub> (the solar simulator not operating) to cause condensation if atmospheric air is in the area. To eliminate this, gaseous nitrogen which has evaporated from the operation of the cold wall is heated, pumped up to, and distributed to each of the relay lenses and thereby prevents any condensation on them.

In addition to the prototype module mentioned above a test fixture has been made in which each element of the system may be individually adjusted. With this fixture (containing all production hardware except for the ellipse) intensities of 160 w/ft.<sup>2</sup> have been achieved. We feel that this performance gives great confidence in the basic capabilities of the system. The problem is how to make 127 equivalent modules.

The prototype system has shown performance as high as 142 w/ft.<sup>2</sup> and when reassembled with changes in lamp, ellipse, parabola, and hyperbola, has consistently shown results of more than 130 w/ft.<sup>2</sup>

Table 1  
Original and Present Specifications

Quantity	Specifications	
	Original	Present
Intensity	50 to 275 w/ft. <sup>2</sup>	50-130 w/ft. <sup>2</sup>
Uniformity	±10% over 1 ft. <sup>2</sup>	±10% over 1 ft. <sup>2</sup>
Collimation	±4° half angle	±4° half angle
Spectral Distribution	Johnson Curve	Fair Match
Area Covered	20 ft. diameter circle	17 ft. diameter uniform fall off to 50% at 20 ft.

As a result of testing the module and its components, we are confident of reaching our goal and are proceeding with the manufacture of all components. At present, expectations—as compared with the original specifications—are given in Table 1.

In explanation of "fair match", this is a subjective opinion based on the use of wide-band filters corresponding to the manner in which the desired spectrum was specified, i. e. equivalent energy absorption for typical materials. These tests, carried out by Dr. Drummond of Eppley Laboratories, indicated that the ultraviolet had been filtered out by the system and that the infrared came through the system with a minimum loss. We chose HgXe lamps as a source because of the much lower maintenance requirements as compared with carbon arcs. Also, the HgXe lamps provided ultraviolet in excess of that found in the solar spectrum, which overcame the normal losses found in an optical system. This has been done with 2 1/2 kw HgXe lamps and the system is designed to accept 5 kw HgXe lamps. As soon as the system is operational, we shall start work on the use of larger lamps which will be used to obtain Venus orbit intensity.

The construction of this simulator has been underway for two years and appears to be approximately one year from completion.

NASA TN D-1917  
National Aeronautics and Space Administration.  
PROBLEMS IN THE CONSTRUCTION OF A SPACE  
ENVIRONMENT SIMULATOR. Dana S. Cope.  
March 1964. iii, 12p. OTS price, \$0.50.  
(NASA TECHNICAL NOTE D-1917)

Goddard Space Flight Center recently constructed a space environment simulator which has advanced the state of the art of environment simulation. Problems concerning the material and construction of reflectors are presented in some detail. At present this facility provides oil-diffusion, cryogenic pumping, and controlled wall temperatures. Solar hardware fabrication is in the process of completion.

- I. Cope, Dana S.
- II. NASA TN D-1917

NASA

- I. Cope, Dana S.
- II. NASA TN D-1917

NASA

NASA TN D-1917  
National Aeronautics and Space Administration.  
PROBLEMS IN THE CONSTRUCTION OF A SPACE  
ENVIRONMENT SIMULATOR. Dana S. Cope.  
March 1964. iii, 12p. OTS price, \$0.50.  
(NASA TECHNICAL NOTE D-1917)

Goddard Space Flight Center recently constructed a space environment simulator which has advanced the state of the art of environment simulation. Problems concerning the material and construction of reflectors are presented in some detail. At present this facility provides oil-diffusion, cryogenic pumping, and controlled wall temperatures. Solar hardware fabrication is in the process of completion.

- I. Cope, Dana S.
- II. NASA TN D-1917

NASA

- I. Cope, Dana S.
- II. NASA TN D-1917

NASA

NASA TN D-1917  
National Aeronautics and Space Administration.  
PROBLEMS IN THE CONSTRUCTION OF A SPACE  
ENVIRONMENT SIMULATOR. Dana S. Cope.  
March 1964. iii, 12p. OTS price, \$0.50.  
(NASA TECHNICAL NOTE D-1917)

Goddard Space Flight Center recently constructed a space environment simulator which has advanced the state of the art of environment simulation. Problems concerning the material and construction of reflectors are presented in some detail. At present this facility provides oil-diffusion, cryogenic pumping, and controlled wall temperatures. Solar hardware fabrication is in the process of completion.

- I. Cope, Dana S.
- II. NASA TN D-1917

NASA

- I. Cope, Dana S.
- II. NASA TN D-1917

NASA

NASA TN D-1917  
National Aeronautics and Space Administration.  
PROBLEMS IN THE CONSTRUCTION OF A SPACE  
ENVIRONMENT SIMULATOR. Dana S. Cope.  
March 1964. iii, 12p. OTS price, \$0.50.  
(NASA TECHNICAL NOTE D-1917)

Goddard Space Flight Center recently constructed a space environment simulator which has advanced the state of the art of environment simulation. Problems concerning the material and construction of reflectors are presented in some detail. At present this facility provides oil-diffusion, cryogenic pumping, and controlled wall temperatures. Solar hardware fabrication is in the process of completion.

- I. Cope, Dana S.
- II. NASA TN D-1917

NASA

- I. Cope, Dana S.
- II. NASA TN D-1917

NASA