

NASA (7) TECHNICAL NOTE

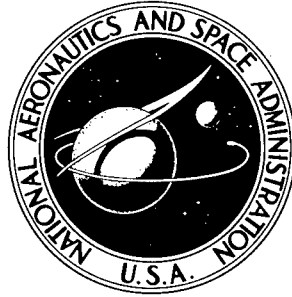

8 NASA TN D-3454

NASA TN D-3454

AMPTIAC

B064837

DISTRIBUTION STATEMENT A  
Approved for Public Release  
Distribution Unlimited

# EFFECT OF FACE-SHEET STIFFNESS ON BUCKLING OF CYLINDRICAL SHELLS OF SANDWICH CONSTRUCTION

by Robert E. Fulton and Nancy P. Sykes

Langley Research Center  
Langley Station, Hampton, Va.

20020329 098

4  
EFFECT OF FACE-SHEET STIFFNESS ON BUCKLING OF  
CYLINDRICAL SHELLS OF SANDWICH CONSTRUCTION

By Robert E. Fulton<sup>1</sup> and Nancy P. Sykes<sup>2</sup>

<sup>5</sup> Langley Research Center  
<sup>6</sup> Langley Station, Hampton, Va.

NATIONAL AERONAUTICS AND SPACE ADMINISTRATION 12

---

For sale by the Clearinghouse for Federal Scientific and Technical Information  
Springfield, Virginia 22151 - Price \$1.00

# EFFECT OF FACE-SHEET STIFFNESS ON BUCKLING OF CYLINDRICAL SHELLS OF SANDWICH CONSTRUCTION

By Robert E. Fulton and Nancy P. Sykes  
Langley Research Center

## SUMMARY

Results are presented for the effect of flexural stiffness of face sheets on the buckling of elastic cylindrical shells of sandwich construction subjected to axial and lateral loading. This study shows that when the core is very weak in shear the flexural stiffness of the face sheets can significantly increase the buckling load. This increase is shown to be much larger for axially loaded shells than for laterally loaded ones. Graphical results are given for a wide range of the significant parameters. The results are based on a linear buckling theory for sandwich shells of the Donnell type, which takes into account the asymmetry of the sandwich faces. *end*

## INTRODUCTION

A number of studies have been made over the past few years of the buckling characteristics of cylindrical shells of sandwich construction. In most of these studies, the contribution of the flexural stiffness of the face sheets has been neglected when considering the buckling characteristics of the sandwich. In certain ranges of the significant parameters this assumption is reasonable; however, in the range where large shearing deformations occur in the core at buckling, it may not be reasonable for certain loading conditions. Reference 1 is a detailed parametric study of the contribution of face-sheet bending stiffness to the buckling load of curved sandwich plates in axial compression. The purpose of this paper is to carry out a similar detailed investigation of this contribution for complete cylinders subjected to either axial or lateral loading. The effect of face-sheet stiffness is shown to be an important factor in certain ranges of the parameters and is greater for axial loading than for lateral loading.

## SYMBOLS

a, b length and circumference of cylinder, respectively ( $b = 2\pi r$ )

B extensional stiffness of a face sheet,  $\frac{Et}{1 - \mu^2}$

c	thickness of core
D	flexural stiffness of a face sheet, $\frac{Et^3}{12(1 - \mu^2)}$
E	Young's modulus for a face sheet
F	Airy stress function
G <sub>c</sub>	shear modulus for core
h	distance between middle surfaces of face sheets
k <sub>x</sub>	buckling-load coefficient for cylinder in axial compression, $\frac{N_x^* a^2 (B_1 + B_2)}{\pi^2 h^2 B_1 B_2}$
k <sub>y</sub>	buckling-load coefficient for cylinder subjected to lateral load, $\frac{N_y^* a^2 (B_1 B_2)}{\pi^2 h^2 B_1 B_2}$
M <sub>x</sub> , M <sub>y</sub>	sum of the individual moments in the two face sheets in x and y directions, respectively
m, n	integers
N <sub>x</sub> <sup>*</sup> , N <sub>y</sub> <sup>*</sup> , N <sub>xy</sub> <sup>*</sup>	stress resultants causing buckling
r	radius to neutral axis of sandwich shell (fig. 1)
S	face-sheet stiffness parameter, $\frac{(B_1 + B_2)(D_1 + D_2)}{h^2 B_1 B_2}$
t	thickness of face sheet
u, v, w	buckling displacements of the shell in the x, y, z directions (fig. 1)
x, y, z	coordinates of the neutral surface of shell (fig. 1)
Z <sub>a</sub> <sup>2</sup>	curvature parameter for cylinder, $\frac{a^4 (B_1 + B_2)^2 (1 - \mu^2)}{r^2 h^2 B_1 B_2}$
α	buckling rotation in x direction, $\frac{1}{h}(u_1 - u_2)$

$\beta$	buckling rotation in $y$ direction, $\frac{1}{h}(v_1 - v_2)$
$\mu$	Poisson's ratio
$\varphi$	coupled rotation variable, $\alpha_{,x} + \beta_{,y}$
$\psi_a$	sandwich core parameter for cylinder, $\frac{\pi^2 c B_1 B_2}{a^2 G_c (B_1 + B_2)}$
$\lambda$	wave-length ratio, $\frac{an}{bm}$
$\nabla^2$	two-dimensional Laplacian operator

Subscripts:

1,2	refer to upper and lower face sheets, respectively
x,y	after commas indicate partial differentiation with respect to the longitudinal and circumferential directions, respectively

### BUCKLING EQUATIONS

The configuration to be considered is a circular cylinder of nonsymmetrical sandwich section subjected to a constant lateral force  $N_y^*$  or a constant axial force  $N_x^*$  (fig. 1). The equations governing the buckling of such a cylinder, taken from references 1 and 2, are

$$\nabla^4 F = -(B_1 + B_2) \left(1 - \mu^2\right) \frac{w_{,xx}}{r} \quad (1a)$$

$$\left[1 - \frac{c B_1 B_2}{G_c (B_1 + B_2)} \nabla^2\right] \varphi = \nabla^2 w \quad (1b)$$

$$(D_1 + D_2) \nabla^4 w - N_x^* w_{,xx} - N_y^* w_{,yy} - \frac{1}{r} F_{,xx} + \frac{h^2 B_1 B_2}{B_1 + B_2} \nabla^2 \varphi = 0 \quad (1c)$$

In these equations the concept of a sandwich is retained, in that the core undergoes only transverse shear deformations so that a line through the undeformed core remains straight when deformed but does not necessarily remain perpendicular to the neutral surface of the sandwich shell. The core is assumed to be elastic, isotropic, and homogeneous; to carry no inplane loads; and to have no deformation in the direction normal to the

neutral surface of the shell. The total thickness of the shell element is assumed to be small compared with the radius of curvature. The face sheets are assumed to be elastic, isotropic, and homogeneous and to conform to the classical shell theory; that is, to satisfy the Kirchhoff-Love condition. Poisson's ratio is taken to be the same for the two face sheets and the core; however, the thicknesses and Young's modulus can be different.

The simply supported boundary conditions at buckling are defined herein as follows along  $x = 0$  and  $x = a$ :

(1) Displacement normal to the surface of the shell vanishes; that is,

$$w = 0 \quad (2a)$$

(2) Moment couple normal to the edge caused by differential inplane forces in the face sheet vanishes; that is,

$$\alpha_{,x} + \mu\beta_{,y} = 0 \quad (2b)$$

(3) The sum of the moment in each of the individual face sheets vanishes; that is,

$$M_x = -(D_1 + D_2)(w_{,xx} + \mu w_{,yy}) = 0 \quad (2c)$$

(4) Displacements parallel to each edge are prevented; that is,

$$v = \frac{B_1 v_1 + B_2 v_2}{B_1 + B_2} = 0 \quad (2d)$$

$$\beta = 0 \quad (2e)$$

(5) Displacements normal to each edge in the neutral surface of the shell occur freely; that is,

$$F_{,yy} = 0 \quad (2f)$$

The solution to equations (1) satisfying the simple-support boundary conditions for  $N_x^*$  and  $N_y^*$  independent of  $x$  and  $y$  is (ref. 1):

$$w = w_0 \sin \frac{m\pi x}{a} \sin \frac{n\pi y}{b} \quad (3)$$

$$F = (B_1 + B_2) \left(1 - \mu^2\right) \frac{w_0}{r} \frac{m^2}{\pi^2 a^2 \left(\frac{m^2}{a^2} + \frac{n^2}{b^2}\right)^2} \sin \frac{m\pi x}{a} \sin \frac{n\pi y}{b} \quad (4)$$

$$\varphi = - \frac{w_0 \pi^2 \left( \frac{m^2}{a^2} + \frac{n^2}{b^2} \right)}{1 + \pi^2 \frac{cB_1 B_2}{G_c (B_1 + B_2)} \left( \frac{m^2}{a^2} + \frac{n^2}{b^2} \right)} \sin \frac{m\pi x}{a} \sin \frac{n\pi y}{b} \quad (5)$$

where  $w_0$  is a constant and  $m$  and  $n$  are integers. Substitution of equations (3), (4), and (5) into equation (1c) yields the buckling condition:

$$\begin{aligned} -N_x^* \pi^2 \frac{m^2}{a^2} - N_y^* \pi^2 \frac{n^2}{b^2} + (D_1 + D_2) \pi^4 \frac{\left( m^2 + \frac{a^2}{b^2} n^2 \right)^2}{a^4} + \frac{(B_1 + B_2)(1 - \mu^2) m^4}{r^2 \left( m^2 + \frac{a^2}{b^2} n^2 \right)^2} \\ + \frac{\frac{h^2 B_1 B_2}{B_1 + B_2} \pi^4 \left( m^2 + \frac{a^2}{b^2} n^2 \right)^2}{a^4 \left[ 1 + \psi_a \left( m^2 + \frac{a^2}{b^2} n^2 \right) \right]} = 0 \end{aligned} \quad (6)$$

where

$$\psi_a = \frac{\pi^2 c B_1 B_2}{a^2 G_c (B_1 + B_2)}$$

It should be noted that equation (6) holds for all ranges of the parameters and is applicable to both curved plates and cylinders. If  $c = 0$ , equation (6) reduces to a Donnell type result for a bilayered shell. With  $c = 0$  and the face sheets symmetrical, it reduces to that given for an isotropic shell in reference 3.

#### Axial Compression

Equation (6) has been specialized to apply to the case of constant axial compression and is

$$k_x = S m^2 (1 + \lambda^2)^2 + \frac{Z_a^2 / \pi^4}{m^2 (1 + \lambda^2)^2} + \frac{m^2 (1 + \lambda^2)^2}{1 + \psi_a m^2 (1 + \lambda^2)} \quad (7)$$

Equation (7) is minimized with respect to  $\lambda$  and  $n$ , where  $\lambda$  is regarded as a continuous variable and  $n$  is an even integer.

The results of these calculations are presented in figure 2. Note that the results for  $S = 0$  (i.e., face-sheet flexural stiffness neglected) shown in figure 2 agree with those given in reference 4, and the results in figure 2(a) for  $S = 0.3333$  and  $c = 0$  ( $t_1 = t_2 = h$ ) agree with those for a homogeneous cylinder given by Batdorf in reference 3.

### Lateral Loading

Equation (6) has been specialized to apply to the case of constant lateral loading and takes the form

$$k_y = \frac{S(1 + \lambda^2)^2}{\lambda^2} + \frac{Z_a^2}{\pi^4 \lambda^2 (1 + \lambda^2)^2} + \frac{(1 + \lambda^2)^2}{\lambda^2 [1 + \psi_a (1 + \lambda^2)]} \quad (8)$$

In equation (8)  $m$  is set equal to 1 and the minimization is carried out with respect to  $\lambda$  (i.e.,  $an/b$ ). The results are given for certain ranges of the parameters in figure 3. For  $S = 0.3333$  and  $c = 0$ , the results given in figure 3(a) again agree with those given by Batdorf (ref. 3) for the homogeneous cylinder.

### DISCUSSION OF RESULTS

A significant result to be noted from figures 2 and 3 is the effect of the face-sheet stiffness on the buckling strength of cylinders under the two different loading conditions. One important range of practical interest for a sandwich is the range  $S < 0.01$ , which corresponds to  $t/h$  less than about 1/6 for a symmetrical sandwich. Under both axial and lateral loading, the effect of face-sheet stiffness for  $S < 0.01$  is not significant for small values of  $Z_a$ . On the other hand, for large values of  $Z_a$  the face-sheet flexural stiffness significantly increases the buckling load of the shell.

For large values of  $Z_a$ , simple approximate buckling formulas which account for face-sheet stiffness may be derived for both axial loading and lateral loading. The results in reference 1 show that for large  $Z_a$  the curves for axial loading approach the curve

$$k_x = \frac{1}{\psi_a} + \frac{2Z_a}{\pi^2} \sqrt{S}$$

A similar analysis indicates that the curves for lateral loading for large  $Z_a$  approach

$$k_y = \frac{1}{\psi_a} + \sqrt{\frac{2Z_a}{\pi^2} \left(\frac{4}{3} S\right)^{3/4}}$$

These two equations show that for large  $Z_a$  the increase in buckling load when  $S$  is not zero is proportional to  $Z_a$  and  $\sqrt{S}$  for axial loading and is proportional to  $\sqrt{Z_a}$  and  $(S)^{3/4}$  for lateral loading. Because  $Z_a$  is large and  $S$  is less than 1, the effect of the face-sheet bending stiffness is more pronounced for axial loading than for lateral loading.

#### CONCLUDING REMARKS

A study has been made of the effect of flexural stiffness of the face sheets on the buckling of elastic cylindrical shells of sandwich construction subjected to axial and lateral loading. Results are given for a wide range of the significant parameters. The results agree at one extreme with classical sandwich theory and at the other extreme with isotropic shell theory. Any face-sheet flexural stiffness is seen to increase the buckling strength of the shell significantly in certain ranges of the shell parameters where the core is weak in shear. Simple buckling formulas are given for these ranges and this increase in buckling strength is much larger for axially loaded cylindrical shells than for laterally loaded ones. *J. E. Lay*

Langley Research Center,  
National Aeronautics and Space Administration,  
Langley Station, Hampton, Va., February 23, 1966.

#### REFERENCES

1. Fulton, Robert E.: Effect of Face-Sheet Stiffness on Buckling of Curved Plates and Cylindrical Shells of Sandwich Construction in Axial Compression. NASA TN D-2783, 1965.
2. Fulton, Robert E.: Nonlinear Equations for a Shallow Unsymmetrical Sandwich Shell of Double Curvature. Developments in Mechanics, Vol. 1, J. E. Lay and L. E. Malvern, eds., Plenum Press, 1961, pp. 365-380.
3. Batdorf, S. B.: A Simplified Method of Elastic-Stability Analysis for Thin Cylindrical Shells. NACA Rept. 874, 1947. (Formerly included in NACA TN's 1341 and 1342.)
4. Stein, Manuel; and Mayers, J.: Compressive Buckling of Simply Supported Curved Plates and Cylinders of Sandwich Construction. NACA TN 2601, 1952.



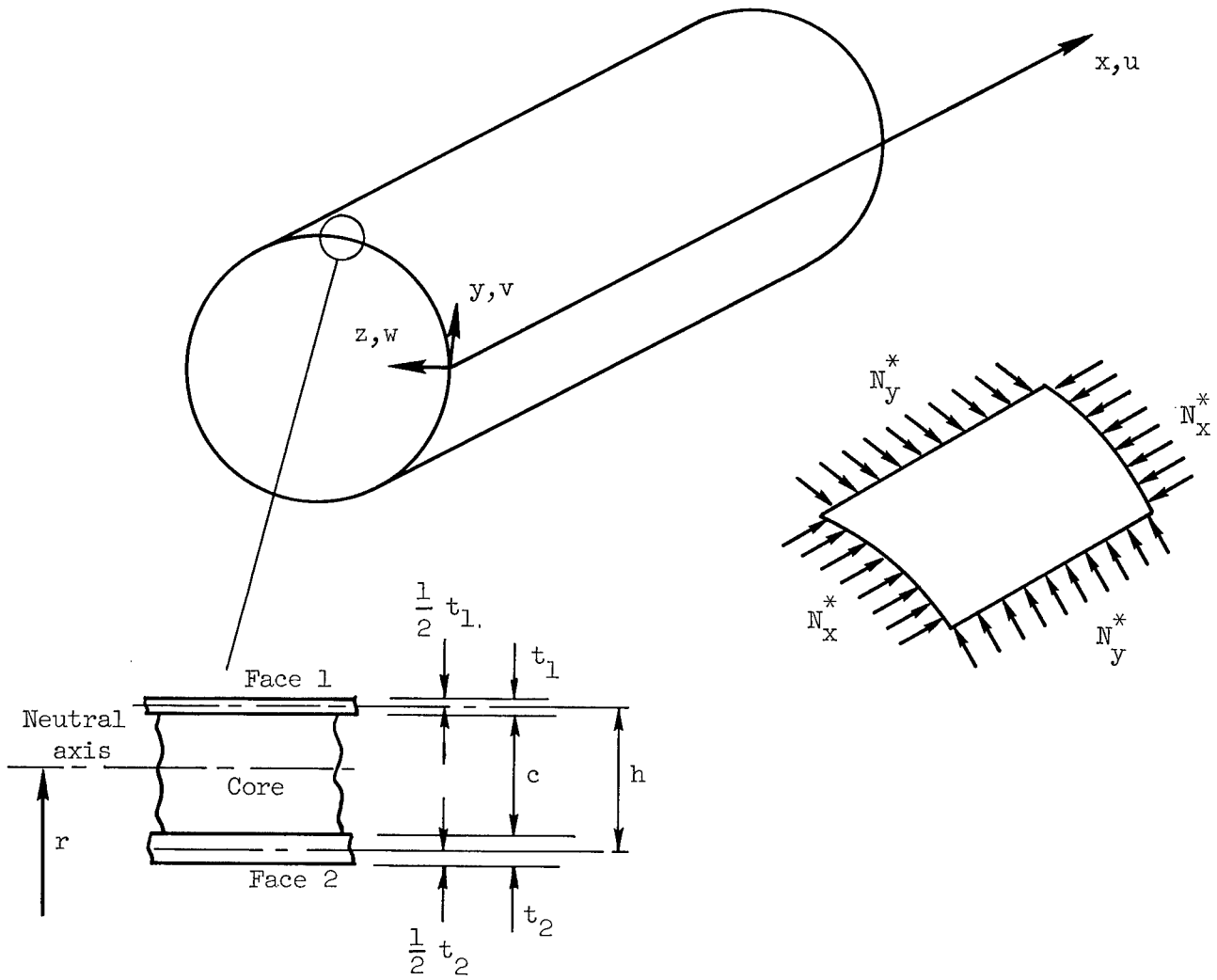

Figure 1.- Cylindrical sandwich shell subjected to axial and lateral loading.

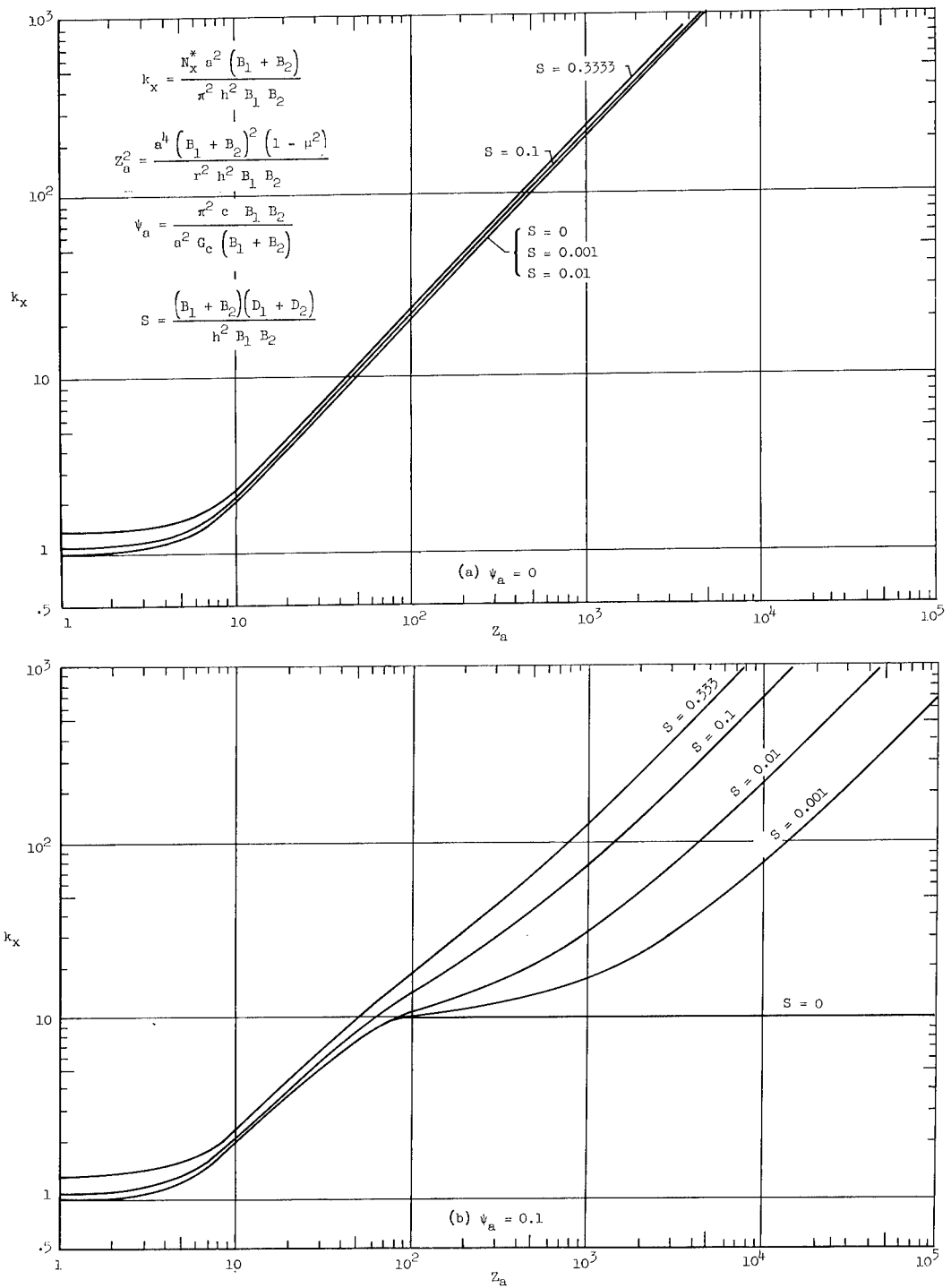

Figure 2.- Buckling coefficients for simply supported cylindrical sandwich shell in axial compression.

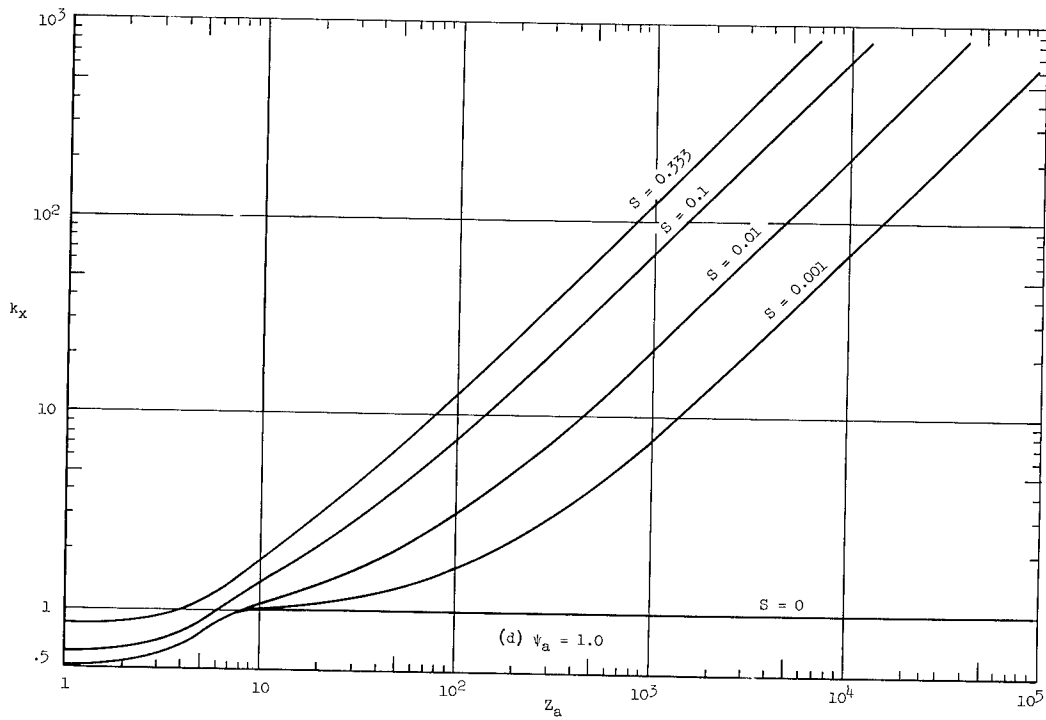
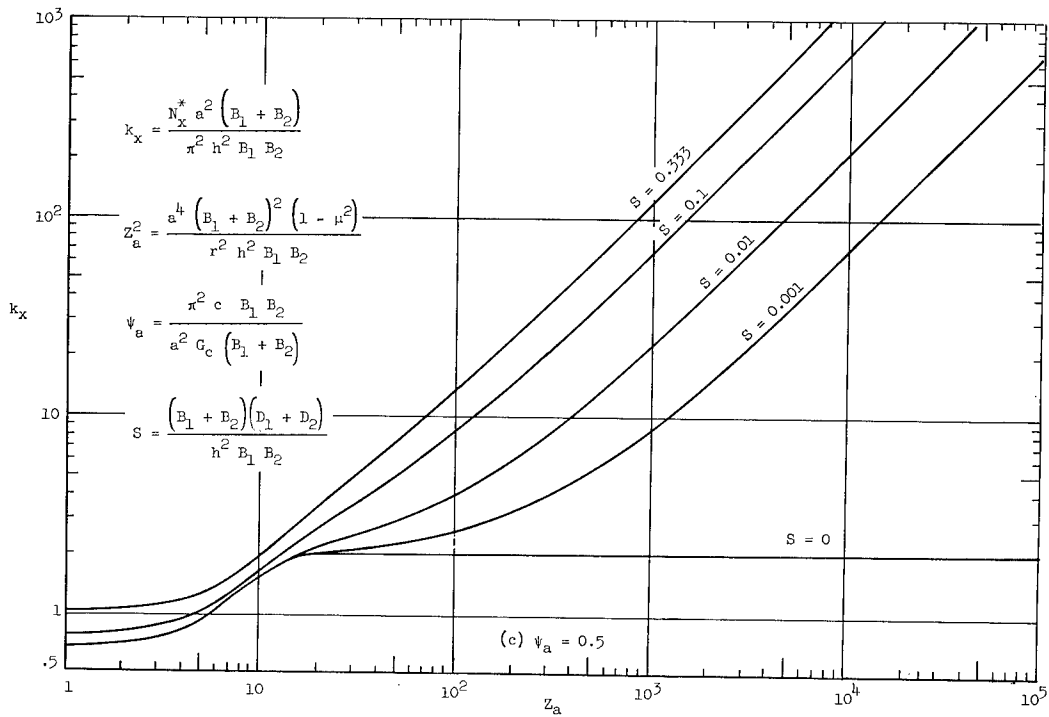

Figure 2.- Concluded.

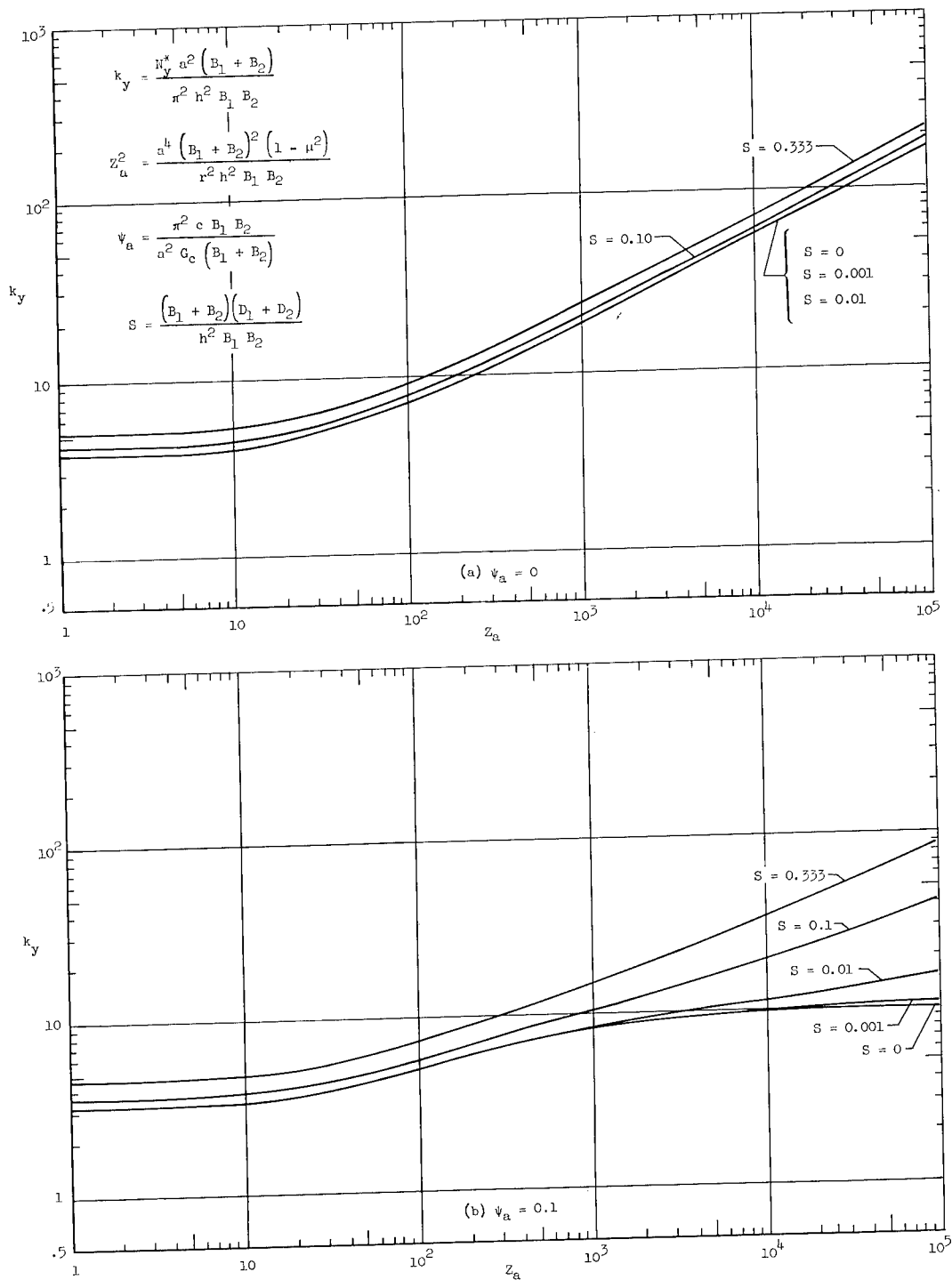

Figure 3.- Buckling coefficients for simply supported cylindrical sandwich shell under lateral loading.

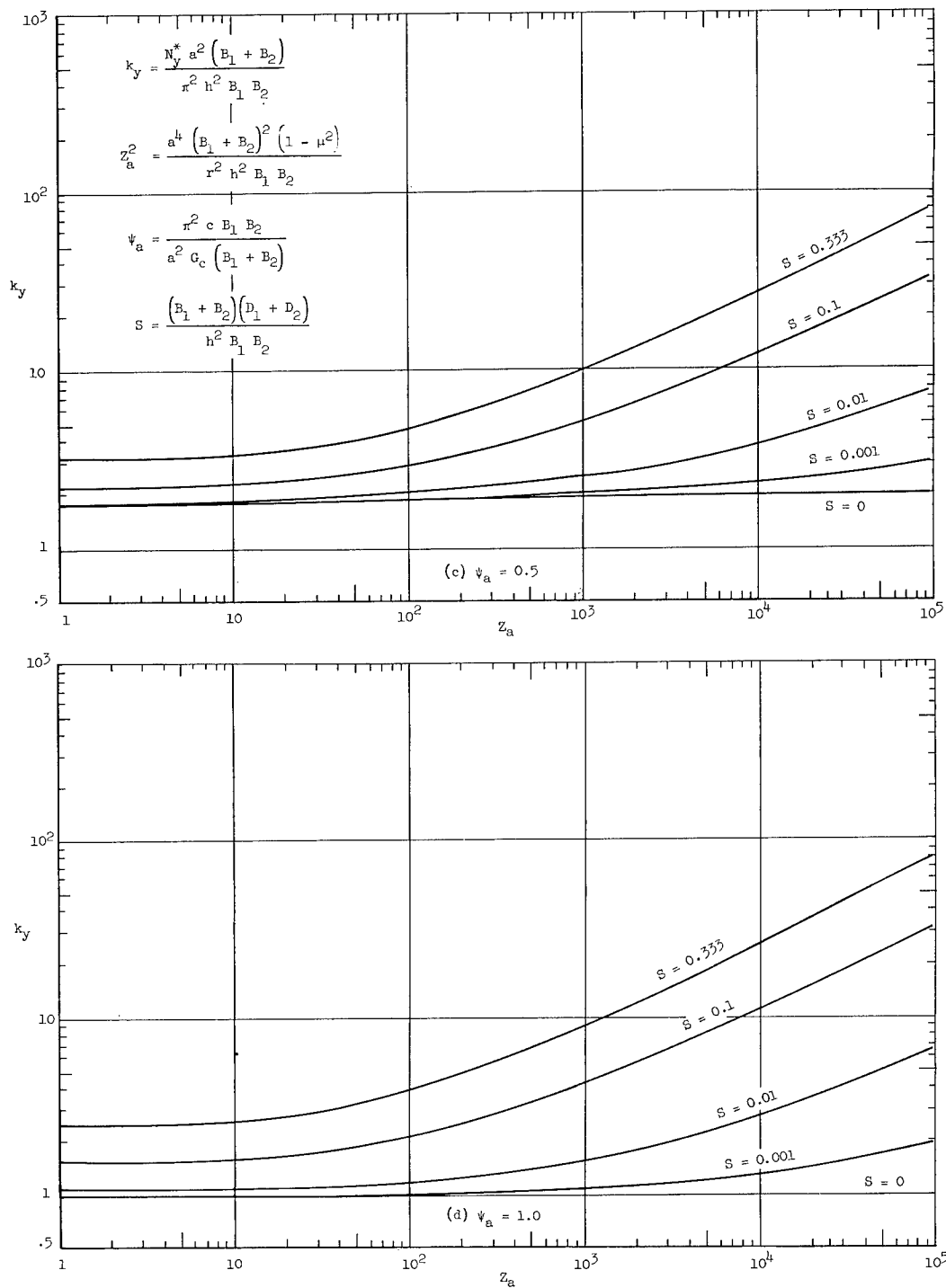

Figure 3.- Concluded.

*"The aeronautical and space activities of the United States shall be conducted so as to contribute . . . to the expansion of human knowledge of phenomena in the atmosphere and space. The Administration shall provide for the widest practicable and appropriate dissemination of information concerning its activities and the results thereof."*

—NATIONAL AERONAUTICS AND SPACE ACT OF 1958

## NASA SCIENTIFIC AND TECHNICAL PUBLICATIONS

**TECHNICAL REPORTS:** Scientific and technical information considered important, complete, and a lasting contribution to existing knowledge.

**TECHNICAL NOTES:** Information less broad in scope but nevertheless of importance as a contribution to existing knowledge.

**TECHNICAL MEMORANDUMS:** Information receiving limited distribution because of preliminary data, security classification, or other reasons.

**CONTRACTOR REPORTS:** Technical information generated in connection with a NASA contract or grant and released under NASA auspices.

**TECHNICAL TRANSLATIONS:** Information published in a foreign language considered to merit NASA distribution in English.

**TECHNICAL REPRINTS:** Information derived from NASA activities and initially published in the form of journal articles.

**SPECIAL PUBLICATIONS:** Information derived from or of value to NASA activities but not necessarily reporting the results of individual NASA-programmed scientific efforts. Publications include conference proceedings, monographs, data compilations, handbooks, sourcebooks, and special bibliographies.

*Details on the availability of these publications may be obtained from:*

SCIENTIFIC AND TECHNICAL INFORMATION DIVISION  
NATIONAL AERONAUTICS AND SPACE ADMINISTRATION

Washington, D.C. 20546