

Right **PRICE** Fair **CREDIT**

Criteria to Improve Financial Incentives
for Army Logistics Decisions



Ellen M. **PINT** Marygail K. **BRAUNER**

John R. **BONDANELLA** Daniel A. **RELLES** Paul **STEINBERG**

RAND
ARROYO CENTER

DISTRIBUTION STATEMENT A:
Approved for Public Release -
Distribution Unlimited

Right **PRICE** Fair **CREDIT**

Criteria to Improve Financial Incentives
for Army Logistics Decisions

Ellen M. **PINT** Marygail K. **BRAUNER**

John R. **BONDANELLA** Daniel A. **RELLES** Paul **STEINBERG**

20020423 196

Prepared for the United States Army

RAND
ARROYO CENTER

Approved for public release; distribution unlimited

The research described in this report was sponsored by the United States Army under Contract No. DASW01-96-C-0004.

Library of Congress Cataloging-in-Publication Data

Pint, Ellen M. (Ellen Marie), 1960-

Right price, fair credit : criteria to improve financial incentives for Army logistics decisions / Ellen M. Pint, Marygail K. Brauner, John R. Bondanella.
p. cm.

"MR-1150."

Includes bibliographical references.

ISBN 0-8330-2952-5

1. United States. Army—Supplies and stores—Prices. 2. Spare parts—Prices—United States. I. Brauner, Marygail K., 1947– II. Bondanella, J. (John), 1944– III. Title.

UC263 .P56 2002
355.6'212'0973—dc21

2001020484

RAND is a nonprofit institution that helps improve policy and decisionmaking through research and analysis. RAND® is a registered trademark. RAND's publications do not necessarily reflect the opinions or policies of its research sponsors.

© Copyright 2002 RAND

All rights reserved. No part of this book may be reproduced in any form by any electronic or mechanical means (including photocopying, recording, or information storage and retrieval) without permission in writing from RAND.

Published 2002 by RAND

1700 Main Street, P.O. Box 2138, Santa Monica, CA 90407-2138

1200 South Hayes Street, Arlington, VA 22202-5050

201 North Craig Street, Suite 102, Pittsburgh, PA 15213

RAND URL: <http://www.rand.org/>

To order RAND documents or to obtain additional information,
contact Distribution Services: Telephone: (310) 451-7002;

Fax: (310) 451-6915; Internet: order@rand.org

PREFACE

This report discusses how prices and credits for spare parts affect the behavior of logistics customers and suppliers and the performance of the Army logistics system as a whole. It describes a set of systemwide criteria for evaluating price and credit policies and applies them to current and proposed policies. It then uses the criteria as a basis to develop the characteristics of an optimal price and credit policy that would support the needs of logistics customers at a lower total cost to the Army.

This analysis is an outgrowth of previous research that evaluated the Army's Integrated Sustainment Maintenance program and proposed price and credit policies for Single Stock Fund (SSF), and that applied Velocity Management's (VM's) "Define-Measure-Improve" (D-M-I) methodology to the Army's logistics financial management system. It should be of interest to financial managers and logistics customers and suppliers in the Army and the Department of Defense (DoD), as well as to business organizations that use transfer pricing mechanisms to promote efficient internal allocation of resources.

The research documented here was sponsored by the Army's Deputy Chief of Staff for Logistics and conducted in the Military Logistics Program of RAND Arroyo Center. The Arroyo Center is a federally funded research and development center sponsored by the United States Army.

For more information on RAND Arroyo Center, contact the Director of Operations (tel 310-393-0411, extension 6500; FAX 310-451-6952; e-mail donnab@rand.org), or visit the Arroyo Center's Web site at <http://www.rand.org/organization/ard/>

CONTENTS

Preface	iii
Figures	vii
Tables	ix
Summary	xi
Abbreviations	xix
Chapter One	
INTRODUCTION	1
Background	1
Objective	3
Organization of this Report	3
Chapter Two	
CRITERIA FOR EVALUATING PRICE AND CREDIT POLICIES	5
Mapping the Army's Financial Management System for Spare Parts	5
Customer and Supplier Decisionmaking in the AWCF System	14
Identifying Criteria to Assess Impacts of Policy Changes ..	19
Chapter Three	
APPLYING CRITERIA TO EVALUATE PAST, CURRENT, AND PROPOSED POLICIES	23
Evaluating Pre-SSF Price and Credit Policy	23
Credit Averaging	24
Basing Credit on Installation Net Asset Position	28

Surcharges	32
Applying the Criteria to the Pre-SSF Policy	36
SSF Price and Credit Policy	37
Credit Averaging	39
Basing Credits on Army Asset Position	41
Surcharges	45
Applying the Criteria to the SSF Policy	46
“Future” Price and Credit Policy	47
Assumption 1: All DLR and FLR Transactions Are Exchanges	48
Assumption 2: Eliminating Credits Would Eliminate “Entrepreneurial” Behavior	50
Applying the Criteria to the “Future” Price and Credit Policy	54
Chapter Four	
CHARACTERISTICS OF AN OPTIMAL PRICE AND CREDIT POLICY	57
Prices	58
Exchange Pricing	59
Credits	61
Assets Not Surplus to National Need	61
Assets Surplus to National Need	63
Applying the Criteria to an “Optimal” Policy	66
Appendix	
HISTORY OF THE REDUCED PRICE INITIATIVE (RPI)	69
Bibliography	71

FIGURES

2.1. The Army's Pre-SSF Financial Management System for Spare Parts	6
2.2. Pre-SSF Supply Management and Depot Maintenance Activity Groups	8
2.3. Describing Customer and Supplier Decisionmaking Helps to Identify Potential Impacts of Policy Alternatives	15
2.4. Criteria to Assess the Impacts of Policy Changes	19
3.1. Credit Averaging May Cause Installations to Target the Wrong Items for Repair	25
3.2. Credit Flow Chart	28
3.3. Credit Variability on a Single Item	30
3.4. Average Credit Rates for Serviceable and Unserviceable Items at Fort Hood	31
3.5. Components of the Supply Management Surcharge	33
3.6. Components of Depot Maintenance Hourly Rates	35
3.7. Application of Criteria to Pre-SSF Policy	36
3.8. SSF Unserviceable Credit Rates as a Percentage of Purchase Price	40
3.9. Application of Criteria to SSF Policy	46
3.10. Army Supply Data Show Significant Numbers of Unmatched Purchases and Returns	50
3.11. OMA-Funded Customers Depend on Credit Flows to Continue Purchasing DLRs	52
3.12. Without Credits, There Are Fewer Sales from the AWCF to the OMA Customer	53
3.13. Application of Criteria to "Future" Policy	54
4.1. Application of Criteria to "Optimal" Policy	67

TABLES

2.1. Fiscal Year 2000 RSF to OMA Credit Rates	12
3.1. Averaging Retail Credits for DLRs Obscures the True Cost of Depot Repair	26
3.2. Item-by-Item Credit Gives Installations the Right Incentives for Local Repair	27
3.3. Zero Credit for Items in Surplus Can Increase Repair Costs	43

SUMMARY

INTRODUCTION

Under the Army's financial management system for spare parts, logistics customers receive Operations and Maintenance, Army (OMA) budgets to buy spare parts from the supply system, and they receive credits when they return parts to the supply system, either for repair or because they are no longer needed in local inventories. The Army's wholesale inventories of spare parts are financed by a "stock fund," which uses its income from the sale of parts, net of credits issued to customers, to pay for repairs and procurement of replacement parts. Thus, the wholesale supply system acts as a "middleman" for logistics customers, buying repairs or procuring replacement parts to replenish inventories to meet customer demands. Some installation-level, or retail, inventories are also financed by stock funds.

During fiscal year (FY) 2001, the Army's stock funds are in a period of transition from separate wholesale and retail components to a Single Stock Fund (SSF). As a result of this change, the Army is implementing new price and credit policies for spare parts. In this document, we compare and evaluate pre-SSF, SSF, and proposed future price and credit policies, and we define the characteristics of an optimal Army price and credit policy.

Prices and credits for spare parts affect logistics customers, who must achieve their mission within a given budget, and Army and DoD logistics suppliers, who must replenish inventories using sales revenues from logistics customers. In some cases, financial policy changes that benefit one group of decisionmakers can have unde-

sired, detrimental consequences for other groups of decisionmakers. For example, if logistics suppliers reduce credit for items with surplus inventories because they no longer need returns to meet demands, they may create a financial incentive for customers to repair these items instead of buying replacements from the supply system, thus increasing total costs to the Army. Therefore, it is important to evaluate policy changes from a systemwide perspective, so that undesired consequences can be anticipated and avoided.

CRITERIA FOR EVALUATING FINANCIAL POLICIES FROM AN ARMY-WIDE PERSPECTIVE

We developed a set of criteria to evaluate price and credit policies from an Army-wide perspective based on the types of decisions that must be made by logistics customers and suppliers, and the effects of these decisions on inventories, cash flows, and the ability of logistics customers in operating units to perform their missions. The Army's overall objective is to maintain the logistics customer's ability to meet mission requirements while keeping weapon systems in operating condition at the lowest total cost. Thus, price and credit policies should be designed so that customers' and suppliers' decisions are appropriate and cost-effective from an Army-wide perspective as well as a local perspective. These criteria are defined as follows.

1. Logistics customers should be able to maintain planned operating tempo (OPTEMPO) within their OMA budgets.
2. Logistics customers should be able to make appropriate, cost-effective changes in local inventory levels to reflect changes in demands for spare parts.
3. Logistics customers should have financial incentives to make appropriate, cost-effective use of local purchase, redistribution, and local versus depot repair.
4. Price and credit policies should not create financial uncertainty for logistics customers.
5. Logistics suppliers should be able to recover their costs so that the stock fund breaks even.

6. Logistics suppliers should be able to reduce surplus inventories that have arisen as a result of downsizing and process improvement.
7. Logistics suppliers should have financial incentives to make appropriate, cost-effective use of depot, contractor, and local repair sources.

EVALUATION OF CURRENT AND PROPOSED PRICE AND CREDIT POLICIES

Applying the criteria described above to the Army's pre-SSF, SSF, and proposed future price and credit policies helps identify areas where financial incentives may motivate logistics customers or suppliers to take actions that are not cost-effective from an Army perspective.

Pre-SSF Price and Credit Policy

The pre-SSF price and credit policy had three major features that did not fit well with these criteria. First, averaging credit rates across a broad range of items created incorrect financial incentives for logistics customers to choose local versus depot repair. Second, basing credits on the installation's net asset position (NAP) created financial uncertainty for customers and created incentives to set up alternative redistribution channels for items that might receive low credit. Third, using the supply management surcharge to recover costs that were fixed or unrelated to supply and repair created financial incentives for customers to go outside the wholesale supply system when they could find alternative sources at lower costs. When logistics customers divert transactions into alternative supply, repair, and redistribution channels, they reduce both cash and materiel flows to the wholesale logistics system, potentially harming its financial health. Furthermore, they may increase total costs to the Army, because local OMA cost savings do not reflect savings to the Army when prices and credits diverge from the Army's costs of replenishing inventories through returns, repairs, and procurement.

SSF Price and Credit Policy

The Army's initial SSF price and credit policies correct some of the shortcomings of the pre-SSF policies, but they leave some problems unresolved. First, credits are based on item-by-item repair costs instead of averages, so customers should have better information about the true costs of depot repair. However, supply system data indicate that repair costs for many items are set at a "default value" based on a percentage of the acquisition cost. Actual repair costs must be updated in automated logistics systems to set more accurate credit rates.

Second, credits are set yearly based on SSF inventory positions instead of local inventory positions; thus, financial uncertainty should be reduced. However, the SSF gives no credit for Army-managed items that are surplus to desired inventory levels, and only 3 percent credit for most non-Army-managed items. These policies are likely to create financial incentives for logistics customers to set up alternative repair and redistribution systems for these items, potentially increasing total costs to the Army. In many cases, it may be more cost-effective from an Army-wide perspective for the SSF to continue to give more credit for these items so that inventories of serviceables and unserviceables can be centrally managed, or to reduce prices to sell off excess inventory.

Third, under SSF, surcharges might potentially be spread over larger bases of sales and depot repairs, but the same cost elements are still included. Thus, although the distortions in financial incentives caused by surcharges may be reduced under the initial SSF price and credit policy, they are not entirely eliminated.

Proposed Future Price and Credit Policy Changes

Recently there has been discussion in the Army financial management community of further price and credit policy changes to become effective in the second phase of SSF, when the inventories currently held by OMA-funded Supply Support Activities will be incorporated into the stock fund. One proposal is to redefine the price of an item as a weighted combination of its acquisition cost and its repair cost, with the weights depending on unserviceable return rates

and washout rates. Credits would be set at approximately 10 percent of the proposed price (including surcharge).

This proposal suffers from two mistaken assumptions. First, the Army's Training Resource Model (TRM), which is used to develop OMA budgets for operating units, assumes that all supply transactions for reparables are exchanges (i.e., every requisition is accompanied by the return of an unserviceable) and that all supply transactions for consumables are purchases of new items. The proposed policy change addresses only those two types of transactions, when in reality, data from automated logistics systems indicate that there are many purchases without matching unserviceable returns, unserviceable returns without matching purchases, serviceable returns of reparables, and returns of consumables. To be complete, the proposed price and credit policy must address all types of transactions.

Second, many Army financial managers believe that eliminating credits will eliminate incentives for logistics customers to behave "entrepreneurially," i.e., to divert transactions from the wholesale supply system to other sources of supply and repair. As a result, they propose that credits be eliminated or minimized, as is the case in the proposed policy. However, the OMA customer's budget is predicated on the receipt of expected flows of credit, so eliminating—or reducing—credit would require an increased OMA budget, unless prices were also reduced. Furthermore, if credits are reduced or eliminated, customers would be given increased financial incentives to repair and redistribute unmatched returns, and total returns to the supply system could be reduced, resulting in higher total repair and replacement costs to the Army.

CHARACTERISTICS OF AN OPTIMAL PRICE AND CREDIT POLICY

The purpose of the Army's price and credit system is to maintain readiness at lower total cost by creating financial incentives for logistics providers to reduce costs and for logistics customers to use resources cost-effectively. In general, these objectives are best achieved when prices and credits reflect the variable costs of each type of transaction as accurately as possible. Fixed costs should be recovered through lump-sum payments or direct appropriations

rather than surcharges. Logistics suppliers will then receive the funds they need to cover their costs, and logistics customers will receive correct information about the costs of the Army's wholesale logistics services for comparison with their own costs or with the costs of local vendors.

Prices could be set more accurately if the variable costs in the supply management surcharge (such as storage, distribution, and transportation costs) were allocated on an item-by-item basis, and fixed costs were funded either through direct appropriations or a lump-sum payment, perhaps assessed at the Major Command level. When variable costs are allocated on an item-by-item basis to the items that generate them, local OMA savings from diverting transactions will also be savings from a global Army perspective. Logistics suppliers will have an incentive to reduce these costs, or they may lose business to other suppliers. Fixed costs should not be included in surcharges, but they should remain visible to customers so that suppliers have an incentive to reduce them when possible.

The Army could reduce financial uncertainty and the number of financial transactions by using an exchange price system, under which logistics customers pay the difference between the price and the credit when a purchase is accompanied by an unserviceable return. Customers would be penalized by the amount of the credit if they failed to return the carcass within a fixed time.

Credits can be thought of as reflecting either the value of a serviceable or unserviceable asset to the Army, or the cost of returning an asset to a serviceable condition and making it available to another customer. Assuming that prices are based on acquisition cost and a surcharge that reflects the variable costs of managing, storing, distributing, and transporting the item, the credit for a serviceable item that is not in surplus at the national level should be set at the acquisition cost. For unserviceable items not in surplus, credit should be based on acquisition cost minus item-by-item repair costs.

Credit for items in surplus at the national level should depend on whether the excess assets are serviceable or unserviceable. When serviceable assets are in surplus in the wholesale system, the Army can delay both repair and procurement. It is important to avoid giving logistics customers incentives to repair unserviceable assets

locally, since these repairs are likely to be inefficient from an Army perspective. Prices and credits should be the same as for items not in surplus, or if inefficient local repairs continue, the Army could either reduce the price or increase the credit for unserviceable items. When unserviceable assets are in surplus, the Army can delay procurement, but it must make repairs to meet demands. It should continue to give credit for serviceable returns, since they can be redistributed to other customers at little cost. In most cases, the Army should also give credit for unserviceable returns, so that inventories can be centrally managed to repair assets in the best condition and to disassemble or dispose of assets in the worst condition. Only in cases where the Army will never need more assets over the lifetime of the weapon system and centralized management of carcasses is not cost-effective should prices be lowered and credit for unserviceable assets be eliminated.

When designing an optimal price and credit policy, it is important to keep in mind that the Army is trying to minimize the real costs of supporting weapon systems, such as repair, procurement, and overhead costs. Prices and credits are simply accounting transactions whose purpose is to create financial incentives for logistics customers and suppliers to reduce real costs to the Army.

ABBREVIATIONS

AAO	Authorized Acquisition Objective
ACALA	Armament and Chemical Acquisition and Logistics Activity
AFWCF	Air Force Working Capital Fund
ALWCRPCT	Allowable Credit Percent
AMC	U.S. Army Materiel Command
AMC-ID	U.S. Army Materiel Command—Installation Division
AMCOM	Aviation and Missile Command
AMDF	Army Master Data File
ANAD	Anniston Army Depot
ASL	Authorized Stockage List
AWCF	Army Working Capital Fund
CASCOM	Combined Arms Support Command
CCAD	Corpus Christi Army Depot
CECOM	Communications-Electronics Command
COE	Center of Excellence
COMSEC	Communications Security

CTASC	Corps/Theater ADP [Automated Data Processing] Service Center
DAASC	Defense Automated Addressing System Center
DALO-RMI	Secondary Items Division, Resource Management Directorate, Office of the Deputy Chief of Staff for Logistics, Headquarters, Department of the Army
DFAS	Defense Finance and Accounting Service
DISA	Defense Information Systems Agency
DLA	Defense Logistics Agency
DLR	Depot-Level Repairable
DLSC	Defense Logistics Services Center
D-M-I	Define-Measure-Improve
DOL	Directorate of Logistics
DRM	Directorate of Resource Management
DRMO	Defense Reutilization and Marketing Office
DRMS	Defense Reutilization and Marketing Service
DS	Direct Support
DSS-W	Defense Supply Service—Washington
EUSA	Eighth U.S. Army (Korea)
FEDLOG	Federal Logistics Catalog
FLR	Field-Level Repairable
FMMC	FORSCOM Materiel Management Center
FORSCOM	U.S. Army Forces Command
FY	Fiscal Year
GS	General Support
GSA	General Services Administration
HQDA	Headquarters Department of the Army
ILAP	Integrated Logistics Analysis Program

ISM	Integrated Sustainment Maintenance
ISM-X	Integrated Sustainment Maintenance Expanded Demonstration
JLSC	Joint Logistics Systems Center
LAC	Latest Acquisition Cost
LEAD	Letterkenny Army Depot
MACOM	Major Command
MATCAT	Materiel Category
MDMS	Maintenance Data Management System
MRL	Maximum Retention Level
NAP	Net Asset Position
NEOF	No Evidence of Failure
NIIN	National Item Identification Number
NMM	National Maintenance Management
NRTS	Not Repairable [at] This Station
NSN	National Stock Number
NSNMDR	National Stock Number Master Data Record
OPTEMPO	Operating Tempo
O&M	Operations and Maintenance
OMA	Operations and Maintenance, Army
OSD	Office of the Secretary of Defense
REP	Reparable
REQ	Required
RIC-GEO	Routing Identifier Code—Geographical Area
RL	Retention Limit
RO	Requirements Objective
ROP	Reorder Point

RPI	Reduced Price Initiative
RRAD	Red River Army Depot
RSF	Retail Stock Fund
RX	Reparable Exchange
SARSS	Standard Army Retail Supply System
SBCCOM	Soldier and Biological Chemical Command
SERV	Serviceable
SMA	Supply Management Army
SSA	Supply Support Activity
SSF	Single Stock Fund
STAMIS	Standard Army Management Information System
STANFINS	Standard Financial System
STARFIARS	Standard Army Financial Inventory Accounting and Reporting System
TACOM	Tank-Automotive and Armaments Command
TRADOC	U.S. Army Training and Doctrine Command
TRM	Training Resource Model
TYAD	Tobyhanna Army Depot
ULLS	Unit-Level Logistics System
USAREUR	U.S. Army Europe
USARPAC	U.S. Army Pacific Command
USARSO	U.S. Army Southern Command
VM	Velocity Management
WSF	Wholesale Stock Fund

BACKGROUND

In April 1992, the Army introduced stock-funding of depot-level reparable (DLRs), a new method of financing spare parts that gave budgets to logistics customers to buy supplies and repairs from Army or DoD logistics suppliers.¹ Under this market-like mechanism, customers pay for items they order and receive credits for items they return. Installation- and wholesale-level inventories are financed by “stock funds,” and suppliers must replenish these inventories with income from sales net of credits so that the stock fund breaks even.² This financing system was intended to provide incentives to both logistics suppliers and customers to maintain the Army’s weapon systems cost-effectively: for the former to reduce costs, and for the latter to use resources wisely.

During fiscal year (FY) 2001, the Army’s supply management stock fund is in a period of transition from separate wholesale and retail components to a Single Stock Fund (SSF). Prior to this change, the stock fund was split into two parts, a Wholesale Stock Fund (WSF),

¹Prior to that time, the Army Materiel Command (AMC) had received appropriated funds to procure and repair DLRs, which were issued to logistics customers based on their stated needs. Other types of spare parts (field-level reparable (FLRs) and consumables) had previously been stock-funded; thus, stock-funding of DLRs brought all types of spare parts under the same type of financial system.

²The wholesale supply system acts as a “middleman” for logistics customers. It maintains inventories of spare parts to meet demands from customers by buying repairs from Army maintenance facilities or private-sector contractors and replacement parts from manufacturers.

which financed the Army's wholesale inventories of spare parts, and a Retail Stock Fund (RSF) with branches at each installation, which financed some local inventories and repair programs. Thus, most sales and returns involved two transactions, between the RSF and the logistics customer, and between the WSF or other source of supply and the RSF. Under SSF, the WSF and RSF are merged, so there is a single point of sales and returns between the stock fund and logistics customers.³

Under the pre-SSF price and credit system, prices were the same for both WSF-RSF and RSF-customer transactions (based on latest acquisition cost (LAC)⁴ plus a surcharge to cover wholesale supply management operating costs), but credit policies differed. WSF-to-RSF credits depended on the condition of the item (serviceable or unserviceable), item-by-item repair costs, and wholesale inventory position, whereas RSF-to-customer credits depended on the condition of the item in some cases, averaged repair costs by materiel category (MATCAT),⁵ and local inventory position. Under SSF, both prices and credits are similar to the previous WSF-RSF policies.

Prices and credits for spare parts affect logistics customers, who must achieve their mission within a given budget, as well as logistics suppliers, who must replenish inventories using sales revenues from logistics customers. As a result of the price and credit policies put in place, logistics customers have, over the time since stock funding was introduced in 1992, developed additional capabilities to repair and redistribute parts and turned to local vendors to buy some supplies and repairs, thus reducing some of their purchases from the wholesale supply system. Although these alternative sources of supply and repair are less expensive from logistics customers' perspective, it is not clear that they are less expensive from an Army-wide perspective, because customers may be duplicating facilities and capabilities that already exist in the wholesale supply system.

³The SSF is also taking possession of some inventories currently held on installations for local redistribution in Operations and Maintenance, Army (OMA) accounts. The changes involved with SSF will be described in greater detail in Chapter Three.

⁴"Latest acquisition cost" is defined as the price paid by the supply system to the manufacturer for the item under the most recent representative contract.

⁵MATCATs are broad categories of parts, such as electronic, aircraft, or tank and automotive.

Price and credit policies may need to be adjusted to ensure that both customers and suppliers have financial incentives to reduce total Army support costs.

Financial policy changes that benefit one group of decisionmakers can have undesired, detrimental consequences on other groups of decisionmakers. For example, if the supply system reduces credit for an item with surplus inventories because it no longer needs returns, it creates a financial incentive for customers to repair the item, even though the supply system may have serviceable items available, thus increasing total costs to the Army. Therefore, it is important to evaluate policy changes from a systemwide perspective, so that undesired consequences can be anticipated and avoided.

OBJECTIVE

The purpose of this report is to develop a set of criteria with which to evaluate Army price and credit policies from a systemwide perspective, and to apply these criteria to the Army's pre-SSF, SSF, and proposed future price and credit policies for spare parts to identify areas for improvement.

ORGANIZATION OF THIS REPORT

In Chapter Two we develop a set of criteria that can be used to evaluate price and credit policies from an Army-wide perspective. In Chapter Three we use the criteria developed in Chapter Two to compare and evaluate pre-SSF and SSF price and credit policies, as well as some proposed future policy changes. The criteria are then used to formulate the characteristics of an optimal price and credit policy for Army logistics in Chapter Four. Appendix A describes the Reduced Price Initiative (RPI), a policy used to reduce wholesale inventories of items in surplus.

**CRITERIA FOR EVALUATING
PRICE AND CREDIT POLICIES**

Changes in the Army's OMA budgeting, price, and credit policies have a particularly strong influence on the behavior of logistics customers, because the customers make purchasing, stockage, repair, and turn-in decisions based on the budgets they receive and the prices and credits they face. In turn, customer behavior has a strong influence on the cash and materiel inflows and outflows of the Army's stock funds and, thus, on their solvency.

The Army has put into place many logistics initiatives intended to maintain readiness at a lower total cost to the Army. The behavior of logistics customers can also influence the success of these initiatives. Therefore, it is important to ensure that financial policies and logistics initiatives are aligned to achieve the desired cost savings for the Army. In this chapter we develop a series of criteria for evaluating financial policies and logistics initiatives to ensure such alignment. We first briefly map the financial management system for spare parts, and discuss changes resulting from SSF. Then we describe the types of decisions made by logistics customers and suppliers in response to that system to identify the potential impacts of policy alternatives. Finally, we identify a series of criteria to assess the impact of policy changes.

**MAPPING THE ARMY'S FINANCIAL MANAGEMENT SYSTEM
FOR SPARE PARTS**

Under the Army's financial management system for logistics, shown in Figure 2.1, customers in operating units receive OMA budgets to buy spare parts from various wholesale logistics supply managers,

RAND MR1150-2.1

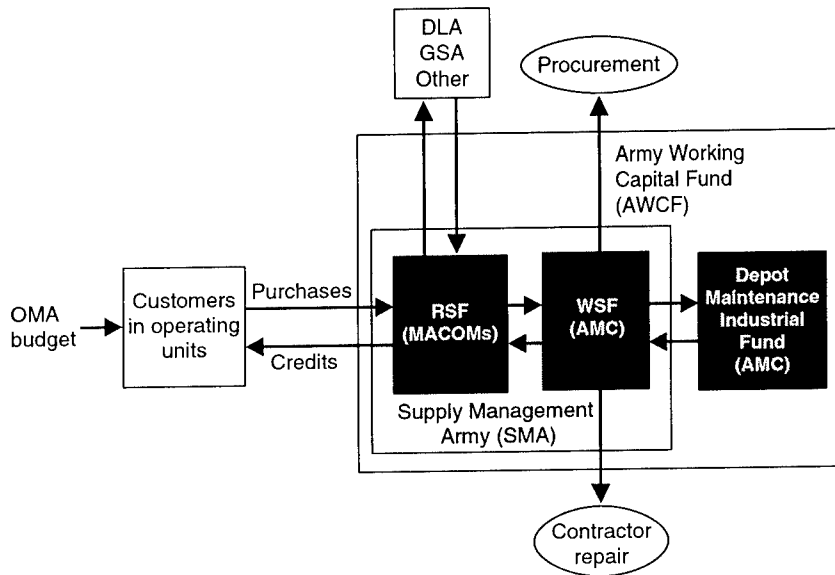

Figure 2.1—The Army’s Pre-SSF Financial Management System for Spare Parts

including the U.S. Army Materiel Command (AMC), the Defense Logistics Agency (DLA), the General Services Administration (GSA), and the other services.¹ These funds may be used for other purposes as well, if the customers can acquire needed parts and repairs for less than the budgeted cost. Customers may also receive credits for returning parts that can be repaired or that are in working condition but no longer needed for local inventories. Prior to SSF, these

¹Generally speaking, AMC manages DLRs, FLRs, and Army-unique consumables; DLA manages all military consumable items that are not service-unique; and GSA manages nonmilitary items, such as office supplies. When a weapon system is used by more than one service, the primary user is designated as the item manager, so the Army also occasionally buys parts from the other services. (Under DoD policy, each item is managed exclusively by one source of supply, i.e., there is no internal price competition.)

purchase and credit transactions passed through the RSF.² Under SSF, the RSF and WSF are being merged, so transactions for Army-owned items go directly to the SSF; transactions for non-Army items pass through the SSF to the source of supply.

Both pre-SSF and SSF wholesale logistics supply managers in AMC use revenues from sales of parts to issue credits, to pay for procurement and repair by AMC maintenance depots or contractors, and to cover operating costs associated with supply management. Prior to SSF, their parts inventories were financed through the WSF. Under SSF, they manage the combined inventories of the former RSF and WSF, now financed by the SSF. These working capital funds are required by DoD financial management regulations to break even over the two-year budget period.³ Repair of spare parts by AMC maintenance depots is financed by the Depot Maintenance Industrial Fund. The maintenance depots must also set their prices to recover parts, labor, and overhead costs so that they break even over the budget cycle. Prior to SSF, the RSF and WSF were both components of the Supply Management Army (SMA) activity group. Under SSF, there is only one stock fund in the SMA activity group. The SMA and Depot Maintenance activity groups are part of the Army Working Capital Fund (AWCF).⁴

²The RSF holds relatively small inventories, so most requisitions are sent to wholesale sources of supply. Some returns are held in the RSF for local repair or redistribution; others are sent to the wholesale source of supply depending on disposition instructions.

³Working capital funds were created on a DoD-wide basis by the National Security Act Amendments of 1949. They can be classified as stock funds or industrial funds. Stock funds finance and hold inventories of parts, subsistence, fuel, and other supplies for sale to military units. Industrial funds finance the operating costs of industrial and commercial-type manufacturing and service activities, such as maintenance depots. Under working capital funding, assets are initially capitalized into the funds, and prices and credits are set to recover operating costs through customer reimbursement. Although surpluses or deficits may develop in the funds from year to year, they must balance out over time. They are budgeted to break even and to eliminate any outstanding operating surplus or deficit over each two-year budget cycle. See Office of the Under Secretary of Defense (Comptroller), *A Plan to Improve the Management and Performance of the Department of Defense Working Capital Funds*, September 1997.

⁴The AWCF also includes the Ordnance activity group, which finances the Army's arsenals, ammunition plants, and ammunition storage depots; and the Information Services activity group, which finances the development and sustainment of automated information and communications systems and coordinates purchases of commercial computer hardware, software, and support services. The SMA also manages

The pre-SSF supply management and depot maintenance activity groups are shown in greater detail in Figure 2.2. As discussed above, the SMA activity group was split into two levels, the RSF and the WSF, which are combined and managed by AMC under SSF. Each of the Army's Major Commands (MACOMs), such as U.S. Army Forces Command (FORSCOM), U.S. Army Training and Doctrine Command (TRADOC), and U.S. Army Europe (USAREUR), controlled its own division of the RSF. Each installation had a RSF office that handled all transactions between OMA-funded logistics customers on that

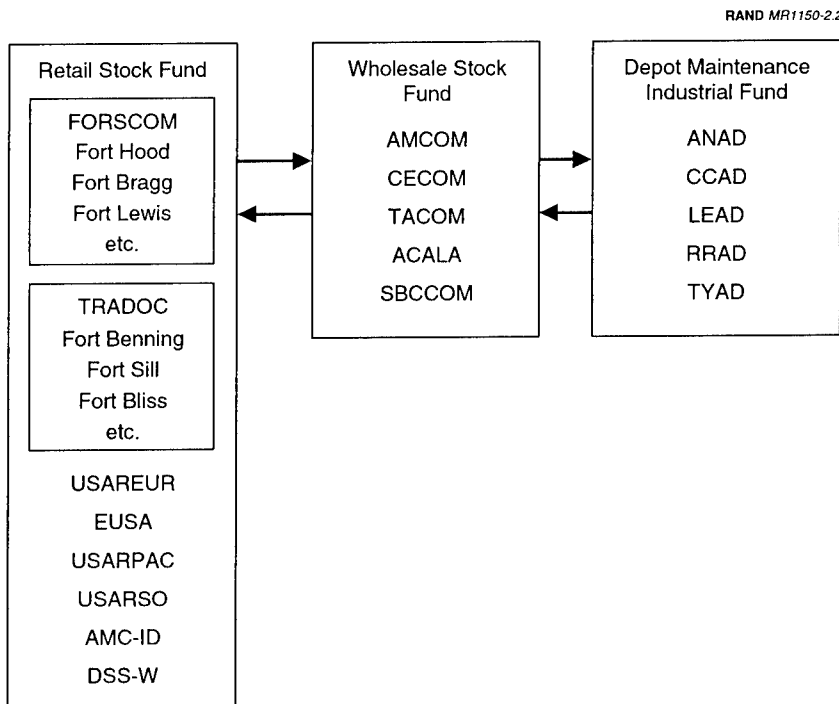

Figure 2.2—Pre-SSF Supply Management and Depot Maintenance Activity Groups

the prepositioned war reserves under Army control. See U.S. Army, Army Working Capital Fund, *FY 2000/2001 Biennial Budget Estimates*, undated.

installation and the wholesale supply system. The installation also held a relatively small amount of inventory in the RSF to support repair activities and Directorate of Logistics (DOL) customers. Installation-level Repairable Exchange (RX) repair programs and the Integrated Sustainment Maintenance (ISM) program⁵ were partially funded by the RSF. The price (net of the credit for an unserviceable return) of an RX or ISM item covered the replacement costs of items that could not be repaired locally (i.e., washouts), and some parts and labor costs, depending on local policy. The remaining parts and labor costs were OMA-funded.⁶ Under SSF, AMC owns and manages the former RSF inventories. It also controls the RX and ISM repair programs under the National Maintenance Management (NMM) program and reimburses installations for items they repair.

Prior to SSF, AMC used the WSF to finance its wholesale inventories of Army-managed parts. These inventories are managed by AMC's Major Subordinate Commands, such as Aviation and Missile Command (AMCOM) and Communications-Electronics Command (CECOM). AMC handled a subset of the transactions passing through the RSF; the remainder went to DLA, GSA, and other sources of supply. AMC financed the bulk of the Army's spare parts inventories through the WSF and used the WSF to pay for procurement and repair programs to maintain the inventories needed to support Army operations. WSF inventories are part of the SSF and remain under AMC management. AMC now uses the SSF to finance the former RSF and WSF inventories and to pay for procurement and repair programs. Component repair programs at AMC's organic maintenance

⁵The RX program is installation-specific; repairs are performed in the installation's General Support (GS) maintenance facilities. The ISM program pools regional GS repair capabilities across installations. Installations become Centers of Excellence (COEs) for the repair of specific items based on a bidding system. Installations within the region send items in the ISM program to the COE for repair.

⁶Although some RSF policies were set at the HQDA level, others, such as the RX credit rate, were controlled by the MACOMs, which could delegate this authority to installations. For example, TRADOC installations cover the costs of washouts, repair parts, and some labor costs through the RSF, but FORSCOM installations only covered the cost of washouts. See Marygail K. Brauner et al., *ISM-X Evaluation and Policy Implications*, Santa Monica, CA: RAND, MR-829-A, 1997. The FORSCOM Allowable Credit Percent (ALWCRPCT) memo for September 1999 stated, "The RX rate of 80 percent is based on a command average of washouts plus NRTS [Not Repairable This Station] for past four quarters. Installations should adjust RX rate based on actual experience of washout rate plus NRTS, using a four quarter average."

depots, such as Anniston Army Depot (ANAD) and Corpus Christi Army Depot (CCAD), are financed by the Depot Maintenance Industrial Fund, which is not affected by the consolidation of the RSF and WSF into the SSF.

The Army's working capital fund system (both pre-SSF and SSF) is intended to create financial incentives for both customers and suppliers of logistics services. Prices and credits should give customers information about the suppliers' costs of repairing and replacing spare parts and financial incentives to use the most cost-effective sources of supply and repair, given the quality and the reliability of each source. Under DoD policy, working-capital-funded logistics suppliers are required to charge prices that cover their full costs, so they have financial incentives to reduce support costs to maintain their customer base (i.e., to remain competitive with other potential sources of supply and repair).

Under the pre-SSF price and credit policy, an item's price was based on its LAC, plus a supply management surcharge to cover operating costs and overheads.⁷ Each wholesale source of supply (AMC, DLA, GSA, etc.) computed its own surcharge based on its own costs, but the RSF did not add a markup to the prices charged by the wholesale suppliers.⁸ Thus, the price an OMA customer paid to the RSF to purchase an item was the same price the RSF paid to the WSF (i.e., AMC) or other source of supply.⁹ When a procurement occurred for an item already in inventory, previously purchased items were revalued and sold at the new LAC plus surcharge. This could potentially create a "profit" or "loss" when the older items are sold, but the

⁷Prices are published monthly in the Army Master Data File (AMDF) and are frequently referred to as AMDF prices. The supply management surcharge is discussed in greater detail in Chapter Three. It includes the costs of item management, transportation, services purchased from DLA, DFAS, and DISA, depreciation, and an adjustment for prior-year gains or losses.

⁸Installations and MACOMs paid for personnel and other RSF operating costs using OMA funds.

⁹Although this is true in general, the prices paid by the customer to the RSF and by the RSF to the wholesale source of supply could differ if the price in the catalog changed between the time the customer paid for the item and the RSF received the interfund bill from the wholesale source of supply. See Marygail K. Brauner et al., *Dollars and Sense: A Process Improvement Approach to Logistics Financial Management*, Santa Monica, CA: RAND, MR-1131-A, 2000.

rationale was that sales revenue should cover the cost of procuring a replacement.

Under SSF, pricing policy will remain the same, but there will be a single point of sale from the SSF to OMA customers for Army-managed items. The SSF surcharge will apply to Army-managed items; there will be no markup on items managed by other sources of supply.

Unlike prices, the pre-SSF credits given by the RSF to OMA customers differed from the credits that the RSF received from wholesale suppliers. The credit given by the RSF to the OMA customer for the return of an item depended on the condition of the item, the average repair and replacement costs by MATCAT, and the installation's Net Asset Position (NAP).¹⁰ If the installation's NAP (the number it held of that type of item) was below its retention limit (RL)¹¹ for the item, (i.e., it was "needed" elsewhere on the installation), the OMA customer generally received a much higher credit than if the NAP was above the retention limit (i.e., the item was "not needed" locally).

Table 2.1 shows the FY00 RSF to OMA credit rates by MATCAT and local need. In general, OMA customers got 100 percent credit for an item that was serviceable (in good working order) and needed locally. If an item was unserviceable (in need of repair), needed locally, and there was an ISM or RX program for the item, OMA customers got 80–85 percent credit for the item. OMA customers got credits of 45–55 percent of the purchase price for DLRs that were not needed locally, whether they were serviceable or unserviceable. Serviceable and unserviceable FLRs and consumables that were not needed locally only got 5 percent credit.

¹⁰Technically, the NAP was determined based on the Standard Army Retail Supply System (SARSS) Routing Identifier Code-Geographical Area (RIC-GEO), but most installations have only one RIC-GEO.

¹¹Each item stocked in a Supply Support Activity (SSA) has a Requirements Objective (RO), a Reorder Point (ROP), and a Retention Limit. When inventories of the item fall to the ROP, the SSA orders enough of the item to reach the RO. Based on HQDA policy, the SSA can set an RL above the RO so that it can retain some returned items for redistribution to its customers. If a customer return puts the SSA's inventory of the item above its RL, it must be returned to the next-highest source of supply. The NAP of an item for the RIC-GEO is compared to the sum of the RLs of that item for all SSAs in the RIC-GEO to determine whether it is "needed."

Table 2.1
Fiscal Year 2000 RSF to OMA Credit Rates

Materiel Category	Credit as Percentage of Purchase Price			
	Serviceable		Unserviceable	
	Needed*	Not Needed	Repairable Locally & Needed	Not Needed
DLRs				
B (Ground Forces Support)	100	63.5	80	63.5
G (Electronics)	100	53.3	80	53.3
H (Air Materiel)	100	53.3	80	53.3
K (Tank and Automotive)	100	52.9	80	52.9
L (Missile Materiel)	100	55.8	80	55.8
M (Weapons, Chemical, and Fire Control)	100	49.9	80	49.9
U (COMSEC Materiel)	100	53.3	80	53.3
FLRs and consumables (FLRs only)				
C (Medical/Dental)	100	5	80	5
E (General Supplies)	100	5	80	5
F (Clothing and Textiles)	100	5	80	5
J (Ground Forces Support)	100	5	80	5
Q (Electronics)	100	5	80	5
R (Petroleum Products)	100	5	80	5
S (Subsistence)	100	100	—	—
T (Industrial Supplies)	100	5	80	5

*The item was "needed" if the installation's net asset position for the item was below its Retention Limit.

SOURCE: FORSCOM ALWCRPCT table, September 1999.

NOTE: There were some exceptions to the above rates; for example, obsolete and condemned items got no credit, and unserviceable consumables may have received 5 percent credit if they contained recoverable materials.

Under pre-SSF policy, credits given by the WSF to the RSF for Army-managed items depended on the condition of the item and the wholesale asset position. If the item was serviceable and within the Maximum Retention Level (MRL), the RSF got a credit equal to LAC (AMDF price minus the surcharge). If the item was an unserviceable

DLR and within the MRL, the RSF got a credit of LAC minus the repair cost of the item, adjusted for washouts.¹² The RSF got no credit for items not needed at the wholesale level (over the MRL). The SSF credit policy is similar to the pre-SSF WSF-to-RSF policy for Army-managed items, with a 3 percent credit for serviceable non-Army-managed items and no credit for unserviceable non-Army-managed items.

Among the other wholesale suppliers, the other services have similar wholesale credit policies, except that they charge “exchange prices” for a purchase accompanied by the return of an unserviceable carcass. Under exchange pricing, the customer pays only the difference between the price and the credit. For unmatched returns, the other services give credits based on LAC and national need for serviceables or item-by-item repair cost and national need for unserviceables. DLA and GSA give credit for serviceable returns only if the item is needed in their inventory.¹³

Price and credit policies from the RSF or SSF to OMA customers create financial incentives for OMA customers. For example, prior to SSF, when installations decided which items to repair in RX and ISM programs, they first determined which items they had the capability and capacity to repair. Of these items, they then selected those whose local OMA repair costs were lower than the AMDF price minus the RSF unserviceable credit.¹⁴ OMA customers may look for local vendors that charge a lower price for an item (or whose repair prices are less than the AMDF price minus the unserviceable credit) when the item has a commercial equivalent. Credits for serviceable returns influence the ability of local customers to adjust their OMA-funded inventories as demands change. If credits are low relative to the purchase price, it is expensive to adjust inventories. Prior to SSF, installations set up OMA retention warehouses to hold serviceable items

¹²The formula for the unserviceable credit rate was $LAC - (1 - \text{washout rate}) \times (\text{repair cost}) - (\text{washout rate}) \times (LAC)$.

¹³We discuss the wholesale suppliers' definition of “need” in Chapter Three.

¹⁴See Marygail K. Brauner et al., *ISM-X Evaluation and Policy Implications*, Santa Monica, CA: RAND, MR-829-A, 1997.

no longer needed by the original purchaser to try to resell them to other OMA customers before returning them to the RSF.¹⁵

Under SSF, AMC is taking control of RX and ISM repair programs and OMA retention stocks, reducing the capability of OMA customers to divert transactions out of the AWCF system. However, customers may still turn to local vendors or develop new workarounds (such as retaining items in OMA-funded SSAs or increasing OMA-funded Direct Support (DS) repairs) if the financial incentives are great enough under SSF price and credit policies.

One of the purposes of establishing a set of criteria to evaluate price and credit policies is to determine whether these types of behavior are cost-effective from an Army-wide point of view.

CUSTOMER AND SUPPLIER DECISIONMAKING IN THE AWCF SYSTEM

Having mapped the financial management system, the next step in developing criteria is to describe the customer and supplier decisions that are influenced by logistics financial policies. Figure 2.3—which is based on Figure 2.1—is intended to be a simplified version of reality, but one that captures the essential elements of the system. It is intended to apply to either the pre-SSF or SSF environment, since similar decisions must be made by customers and suppliers in both environments. As Figure 2.3 indicates, the RSF and the WSF are combined under SSF.¹⁶ We begin from the perspective of the logistics customer's decision problem and trace the effects of price and credit changes on customer decisions and on the rest of the logistics system.

¹⁵Such practices typically increase the time a customer must wait for a part. See Mark Wang, *Accelerated Logistics: Streamlining the Army's Supply Chain*, Santa Monica, CA: RAND, MR-1140-A, 2000.

¹⁶As discussed above, SSF also removes some options from customers, such as OMA retention facilities and ISM/RX repairs. In addition, it introduces new options for suppliers, since ISM/RX will become a more readily available source of repair for AMC item managers. AMC can reposition items among former RSF sites and wholesale inventories, or redistribute AWCF-owned items across installations.

RAND MR1150-2.3

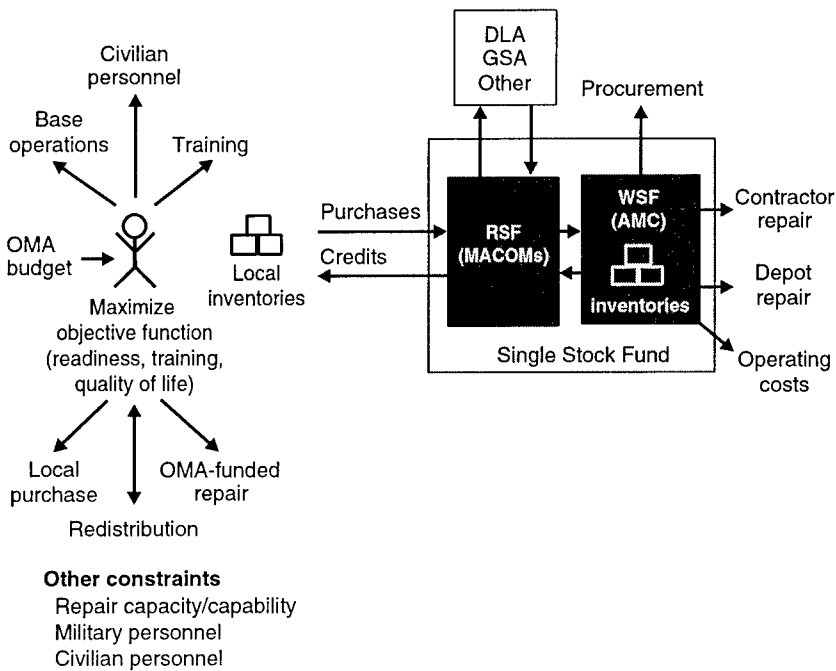

Figure 2.3—Describing Customer and Supplier Decisionmaking Helps to Identify Potential Impacts of Policy Alternatives

Starting on the left side of the figure, the logistics customer (who can be thought of as an installation or division commander) receives an OMA budget. He or she has a set of objectives to achieve within that budget, such as maintaining readiness, meeting a training schedule, and maintaining the quality of life for soldiers and their families. To achieve these objectives, he can spend his OMA budget on training exercises, base operations, civilian personnel, or logistics transactions, including purchases from and turn-ins to the wholesale logistics system, OMA-funded repair, lateral redistribution of items within or across installations, and local purchase.¹⁷ The OMA cus-

¹⁷Army Regulation 710-2, paragraph 4.20, states that a local purchase decision can be made (1) in an emergency; (2) when the wholesale item manager has granted

customer also makes stockage decisions on items held in local inventories. In addition to the OMA budget, other constraints on the OMA customer's choices include the installation's OMA-funded repair capabilities and capacity, and limits on the number of authorizations for military and civilian personnel.

A change in a price or credit can affect many of the OMA customer's decisions. For example, if the purchase price (i.e., the AMDF price) of an item increases, or the net price of a purchase with a return (the AMDF price minus the credit) increases, we would expect the purchases of that item to fall to the extent that the OMA customer (at the SSA or division level) can delay replacing the item or can use less-expensive alternative sources of supply or repair.¹⁸ We would also expect demand for complements, such as training, to fall.¹⁹ Conversely, demand for substitutes, such as local purchase, redistribution, or OMA-funded repair, is likely to rise. To the extent that items or repair capability are available on the local market, local purchase can be a substitute for purchases or repairs from the wholesale logistics system. Lateral redistribution can be a substitute for returning

authority; (3) when the item is not in the AMDF; or (4) "when it is judged to be in the best interest of the Government in terms of the combination of quality, timeliness, and cost," subject to justifications for items costing more than \$2,500. Local purchase may not be used without the approval of the wholesale item manager for items costing more than \$100,000, items that are critical to the safe operation of a weapon system, items with special security characteristics, explosives and munitions, aviation time change components, or small arms. Similar conditions are listed in the Defense Federal Acquisition Regulation Supplement, Subpart 208.7003-1.

Surcharges that include fixed costs could cause customers to choose local purchase under condition (4) above when it is not cost-effective from an Army-wide or DoD-wide perspective. For example, due to volume discounts, the Army or DLA could have a lower acquisition cost and variable costs of stocking and handling an item than a local vendor, but the surcharge could cause the AMDF price to exceed the local vendor's price.

¹⁸OMA customers' budgets are adjusted annually to account for price and credit changes in each fiscal year, based on the Army's Training Resource Model (TRM). Thus, the OMA customer's budget should be adequate to buy the same items bought in previous years, on average. However, if relative prices change, the mix of items purchased is likely to change, to the extent that customers have alternative options for supply and repair or can adjust local inventories up and down.

¹⁹Complements are defined as items that are bought or consumed in combination, such as peanut butter and jelly, or computer hardware and software. Training is a complement to purchases from the wholesale logistics system in the sense that vehicles break down, components need to be replaced, or faults are discovered during training, resulting in logistics transactions.

excess serviceables (which could result from adjusting inventory levels, equipment changes, or incorrect ordering) to the wholesale logistics system. OMA-funded repair can be a substitute for returning an unserviceable item and purchasing a serviceable replacement from the wholesale system.

We might also expect to see changes in OMA expenditures on base operations or civilian personnel, but it is more difficult to predict the direction of these changes, since elements of these expenditures could be substitutes for, complements of, or uncorrelated with logistics transactions.

Specifically, the types of customer decisions that could be affected by price and credit policies include the following:

- **Return or redistribute.** When demand rates change, logistics customers may need to adjust local inventory levels, i.e., return some serviceable items and buy others. Serviceable items may also be in excess because of errors in ordering or in diagnosis of faults during repair. Customers must decide whether to return these serviceable items to the supply system or to redistribute them among themselves.
- **Exchange or repair.** When an item is broken, customers may have up to three options depending on local repair capabilities and capacity: purchase a replacement and return the unserviceable carcass to the supply system, repair the item in installation repair facilities, or purchase a repair from local vendors.
- **Purchase from supply system or local vendor.** When consumable items must be replaced, customers may have the option to buy them from the supply system or from local vendors if the items have a commercial equivalent.
- **Increase or decrease operating tempo (OPTEMPO).** Customers must monitor their OMA spending relative to their budget throughout the fiscal year. If they are spending at a lower or higher rate than expected, they may increase or decrease the rate at which they operate their equipment. Large fluctuations in the prices they pay or the credits they receive for an item (such as those caused by the policy of basing credit on local need)

increase financial uncertainty and make it more difficult for customers to plan their spending relative to their budget.

Financial considerations are only one factor affecting the decisions of logistics customers. Customers may also care about the speed with which an item is delivered or repaired and the quality of the service, for example. Taking all these factors into account, customers make decisions that are cost-effective from the local perspective. Ideally, prices and credits should provide accurate information to logistics customers about the costs of the wholesale supply system for comparison with the costs of local purchase, local repairs, and redistribution, so that when a customer makes a decision that reduces his costs, he also saves money for the Army as a whole.

Price and credit policies also affect the decisions of logistics suppliers and their ability to meet supply system goals:

- **Depot, contractor, or local repair.** Item managers can use organic maintenance depots, contractors, or installations (through the pre-SSF ISM national workload program or the SSF National Maintenance Management program) to repair unserviceable items returned by customers, depending on capability, capacity, and constraints on the total amount of depot maintenance that can be contracted out.²⁰
- **Keep stock funds in balance.** Price and credit policies affect the ability of logistics suppliers to recover their costs and keep the Army's stock funds in balance.
- **Reduce surplus inventories.** In part as a result of the post-Cold War drawdown, the Army has surplus inventories of many items. When serviceable items are in surplus, supply managers can delay both repair and procurement. When unserviceable items are in surplus, supply managers can repair them to meet demands and delay procurement.

²⁰Under 10 U.S. Code 2466, not more than 50 percent of the funds made available in a fiscal year to a military department or defense agency for depot-level maintenance and repair can be used by the private sector. Another provision, 10 U.S. Code 2460, defines which types of repairs are considered to be depot-level maintenance.

Price and credit policies should also be set to give logistics suppliers the financial incentives to make decisions that are cost-effective from an Army-wide perspective.

IDENTIFYING CRITERIA TO ASSESS IMPACTS OF POLICY CHANGES

The cash flow map and the analysis of the potential effects of price and credit policies on customer and supplier behavior lead us to some proposed criteria (see Figure 2.4) for assessing the Army-wide impacts of financial policy changes. These criteria are based on the overall objective of maintaining the logistics customer’s ability to meet mission requirements while keeping weapon systems in operating condition at the lowest total cost to the Army. Thus,

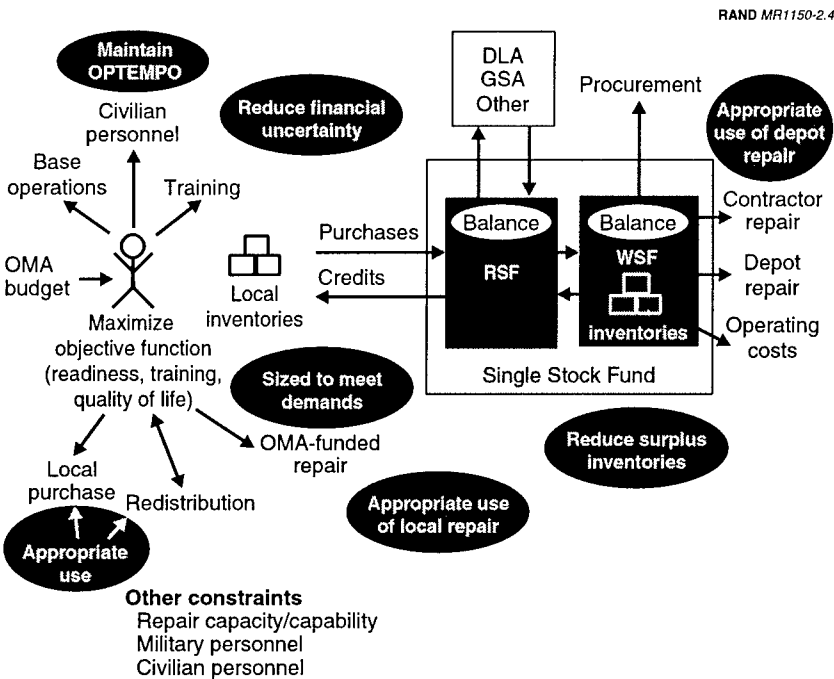

Figure 2.4—Criteria to Assess the Impacts of Policy Changes

customers' and suppliers' decisions should be appropriate and cost-effective from an Army-wide perspective as well as a local perspective. The first four criteria are for logistics customers, while the last three are for logistics suppliers.

1. Logistics customers should be able to maintain planned OPTEMPO within their OMA budgets.²¹
2. Logistics customers should be able to make appropriate, cost-effective changes in local inventory levels to reflect changes in demands for spare parts.
3. Logistics customers should have financial incentives to make appropriate, cost-effective use of local purchase, redistribution, and local versus depot repair.
4. Price and credit policies should not create financial uncertainty for logistics customers.²²
5. Logistics suppliers should be able to recover their costs and keep the stock funds in balance.²³
6. Logistics suppliers should be able to reduce surplus inventories that have arisen as a result of downsizing and process improvement.
7. Logistics suppliers should have financial incentives to make appropriate, cost-effective use of depot, contractor, and local repair sources.

To meet the Army's mission requirements, customers should be able to maintain planned OPTEMPO within their OMA logistics budget, and to make cost-effective adjustments to local inventory levels to reflect changes in demand patterns for spare parts. Prices and cred-

²¹In an *ex ante* sense, budgets should be adequate to maintain planned OPTEMPO, given price and credit policies. If missions or the costs of inputs change during the year of execution, customers may not be able to meet planned OPTEMPO without supplemental funds.

²²Some financial uncertainty is inevitable, such as the cost of unforeseen deployments or changes in the costs of inputs used by the Army. Price and credit policies should not create additional uncertainty, e.g., by basing credits on installation need.

²³In some cases, stock fund revenues might need to recover more than their current costs, for example, to maintain surge capacity or increase inventory levels.

its should give them the correct financial information about supply system costs so that they can make decisions about when to use local purchase, redistribution, or local repair versus depot repair that are cost-effective from an Army-wide perspective. In addition, large and abrupt changes in prices and credits that do not reflect changes in costs to the Army (such as those caused by basing credits on the installation's NAP) should be avoided, because they compromise the ability of commanders to manage logistics budgets and plan future spending.

On the supply side, price and credit policy (including any lump-sum payments or direct appropriations) should allow logistics suppliers to recover their costs and thus keep the AWCF in balance. It should also enable logistics suppliers to reduce surplus inventories and to make repair decisions that are cost-effective from an Army-wide perspective.

Conflicts could potentially arise between these criteria. For example, the Army may need to give credit for items in surplus so that logistics customers do not inefficiently expend resources on local repair (criterion 3), but if logistics suppliers cannot resell these items, the stock fund will not break even (criterion 5). When conflicts arise, one must appeal to the overall objective of logistics financial management policy: to meet mission requirements while maintaining equipment readiness at the lowest total cost to the Army. Surplus inventories are a sunk cost, so stock fund losses do not represent a current cost to the Army, whereas inefficient repairs increase the Army's current cost of maintaining readiness. Thus, criterion 3 should outweigh criterion 5 in this example.

The Army may also need to take deployment considerations into account. Logistics and financial policies that minimize the cost of weapon system support in peacetime may involve activities that are not feasible in deployed environments. For example, when logistics customers are deployed, local vendors may not be available for repairs or spare parts. In these types of cases, the Army may want to adjust price and credit policies to discourage behavior that is not feasible in deployment. Alternatively, it may be possible to overcome potential problems by changing other logistics policies. In this example, if the Army (or DLA) could monitor demands on local ven-

dors, it could maintain sufficient inventories to meet expected additional demands during deployments.

**APPLYING CRITERIA TO EVALUATE PAST,
CURRENT, AND PROPOSED POLICIES**

In this chapter we apply the criteria developed in Chapter Two to the Army's pre-SSF price and credit policy, the SSF policy, and an Army proposal for a future price and credit policy. As we will discuss, the initial SSF policy corrects several of the shortcomings of the pre-SSF price and credit policies, but it leaves some problems unresolved. In contrast, the proposed future policy could have the unintended consequences of increasing customers' incentives to develop alternative supply and repair channels outside the wholesale supply system, and increasing total support costs.

EVALUATING PRE-SSF PRICE AND CREDIT POLICY

The pre-SSF price and credit policy had three major features that did not fit well with the systemwide criteria developed in Chapter Two. First, averaging credit rates across a broad range of items created incorrect financial incentives for logistics customers to choose local versus depot repair. Second, basing credits on the installation's NAP created financial uncertainty for customers, created incentives to set up alternative redistribution channels for items that could receive low credit, and could label an item "not needed" that was critically needed elsewhere in the Army. Third, using the supply management surcharge to recover costs that are fixed or unrelated to supply and repair created financial incentives for customers to go outside the wholesale supply system when they could find lower-cost alternative sources. When logistics customers divert transactions into alternative supply, repair, and redistribution channels, they reduce both cash and materiel flows to the wholesale logistics system, potentially harming its financial health. We discuss each of these issues in turn.

Credit Averaging

One aspect of the pre-SSF price and credit policy that could affect the repair decisions of OMA customers was the practice—discussed in Chapter Two—of averaging the credit rates given by the RSF to OMA customers within MATCATs. (In contrast, credits given from the WSF to the RSF were set item by item, based on depot overhaul cost. A similar policy has been adopted under SSF.)

Figure 3.1 compares the depot repair cost with the ISM (local) repair cost for a selection of items from the ISM-X evaluation.^{1, 2, 3} The x-axis shows depot repair costs as a percentage of AMDF price, and the y-axis shows the ISM repair cost as a percentage of the AMDF price. (For example, the depot repair cost is 25 percent of AMDF price and the ISM repair cost is 41 percent of AMDF price for the circled item in the light gray region.) The items shown in the figure are managed by Aviation and Missile Command (black squares), Communications-Electronics Command (white triangles), or Tank-Automotive and Armaments Command (gray diamonds). From a systemwide or global Army perspective, items below the diagonal line are less expensive to repair in ISM than in the depot.

However, the pre-SSF policy of credit averaging created a financial incentive for customers to repair items below the horizontal line instead of the diagonal line. (For simplicity, we set the horizontal line at 50 percent of AMDF price. Actual credit rates were in the range of 45–55 percent.) As a result, in the light gray region, installations had a financial incentive to repair items in ISM even though depot repair was less expensive from a global Army perspective. In the dark gray region, installations had a financial incentive to send items back to the depot even though ISM repair was less expensive from a global Army perspective.

¹The items shown in Figure 3.1 are not a representative sample of items that could be repaired either locally or in depots, since ISM items were selected to achieve OMA savings under pre-SSF price and credit policies or to improve responsiveness. However, data on local repair costs are not typically available for randomly selected items.

²For further information on the ISM-X evaluation, see Marygail K. Brauner et al., *ISM-X Evaluation and Policy Implications*, Santa Monica, CA: RAND, MR-829-A, 1997.

³Under SSF, GS RX and ISM inventories are owned by the AWCF, so all ISM repair is done in the NMM program.

RAND MR1150-3.1

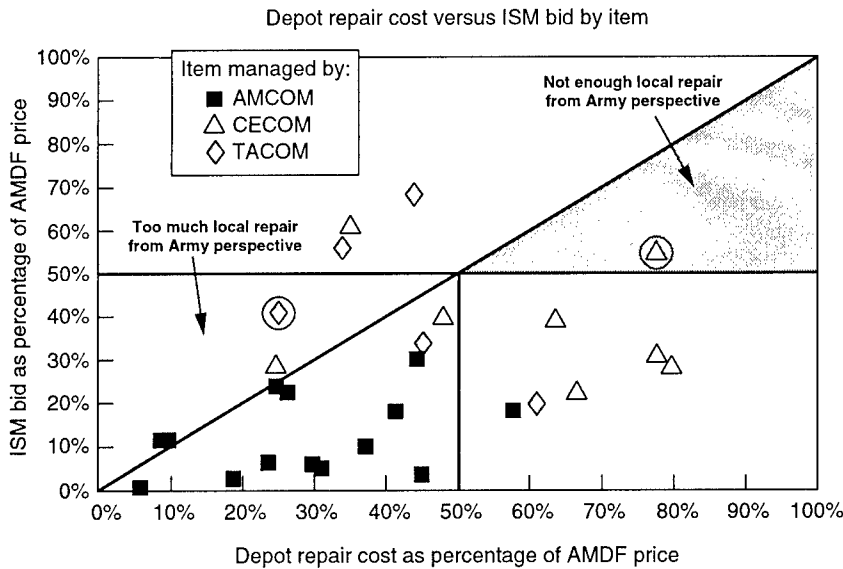

SOURCE: Selection of items from ISM-X evaluation.

Figure 3.1—Credit Averaging May Cause Installations to Target the Wrong Items for Repair

Table 3.1 examines one item from the light gray region and one item from the dark gray region in greater detail (the circled items on the figure). The circled item from the light gray region is an Avionics Display Unit with an AMDF price of \$20,461. The pre-SSF credit for this item was 45.2 percent of AMDF price, or \$9,248. Thus, OMA customers faced a net price of \$11,213 if they sent the item back to the depot and bought a replacement. Since the ISM repair cost was \$8,356, customers retained an OMA savings of \$2,857 when repairing the item in ISM instead of sending it to the depot. But from a global Army perspective, the depot repair cost was actually \$5,137, so repairing the item in ISM actually cost the Army \$3,219 more than sending it back to the depot.

Table 3.1

Averaging Retail Credits for DLRs Obscures the True Cost of Depot Repair

	Avionics Display Unit		M109 Vaneaxial Fan	
	Local Viewpoint	Army Viewpoint	Local Viewpoint	Army Viewpoint
Price	20,461		1,211	
Credit (averaged)	9,248		601	
Net price (price – credit)	11,213		610	
Actual depot repair cost		5,137		938
ISM repair cost	8,356	8,356	664	664
Local OMA savings	2,857		-53	
Army savings		-3,219		274

The item from the dark gray region is the M109 Vaneaxial Fan, which had an AMDF price of \$1,211. The pre-SSF credit for this item was \$601, or 49.6 percent of AMDF price. Therefore, OMA customers faced a net price of \$610 if they sent the item back to the depot and bought a replacement. The ISM repair cost for this item was \$664, so OMA customers incurred a \$53 loss in OMA funds from repairing the item in ISM instead of sending it to the depot. But from a global Army perspective, the depot repair cost was \$938, so the Army gained a \$274 savings when the item was repaired in ISM instead of the depot.⁴

Thus, the policy of credit averaging could send the wrong financial signals about which items to repair locally and which to send back to the depot for repair. Item-by-item credit policy based on Army costs could help motivate OMA customers to choose local repair when it is cost-effective from an Army perspective and to send items back to the wholesale system otherwise. Going back to Figure 3.1, items below the diagonal line were less expensive to repair in ISM than in the depot. To give OMA customers a financial incentive to repair items in the shaded region, credit should be set on an item-by-item basis so that the net price reflects the depot repair cost. When credits

⁴The M109 Vaneaxial Fan was repaired in ISM because the participating installations were willing to incur a small financial loss per repair in order to improve responsiveness.

are set item by item to reflect Army costs, there is a local OMA savings from local repair only if there is a cost savings to the Army as a whole.

To illustrate this point, we examine the same two circled items. Detailed information is shown in Table 3.2. In both cases, when credit is set on an item-by-item basis so that net price equals the actual depot repair cost, OMA customers have a financial incentive to choose local repair only if it is cost-effective from a global Army perspective. The OMA customers' loss of \$3,219 would be the same as the Army's loss if they repaired the Avionics Display Unit in ISM; their gain of \$274 would be the same as the Army's gain if they repaired the M109 Vaneaxial Fan in ISM. Thus, the locally optimal decision would also be the globally optimal decision, and customers would be likely to send the Avionics Display Unit back to the wholesale system for repair and to repair the M109 Vaneaxial Fan in ISM. When OMA customers have correct information about costs, they can make decisions that are best for them and best for the Army.⁵

Table 3.2
Item-by-Item Credit Gives Installations the Right Incentives for Local Repair

	Avionics Display Unit		M109 Vaneaxial Fan	
	Local Viewpoint	Army Viewpoint	Local Viewpoint	Army Viewpoint
Price	20,461		1,211	
Credit (item by item)	15,324		273	
Net price (price – credit)	5,137		938	
Actual depot repair cost		5,137		938
ISM repair cost	8,356	8,356	664	664
Local OMA savings	-3,219		274	
Army savings		-3,219		274

⁵Under SSF, ISM and RX repairs are funded by the AWCF, but DS repairs will continue to be OMA-funded, at least in the short term. In general, as long as some repairs are OMA-funded, OMA customers at the division level will be able to make some decisions about which items to repair.

Basing Credit on Installation Net Asset Position

As Table 2.1 indicated, the pre-SSF credit given by the RSF to OMA customers depended on whether the item was needed elsewhere on the installation. The uncertainty generated by this policy can best be illustrated from the point of view of the customer. Figure 3.2 shows a flow chart drawn from the perspective of a customer in an operating unit. Beginning at the arrow at the bottom of the figure, when customers had an item to return, they knew whether the item was reparable (REP in the figure) or not, whether it was a depot-level reparable (DLR) or a field-level reparable, and whether it was serviceable (SERV). However, customers did not know whether the item

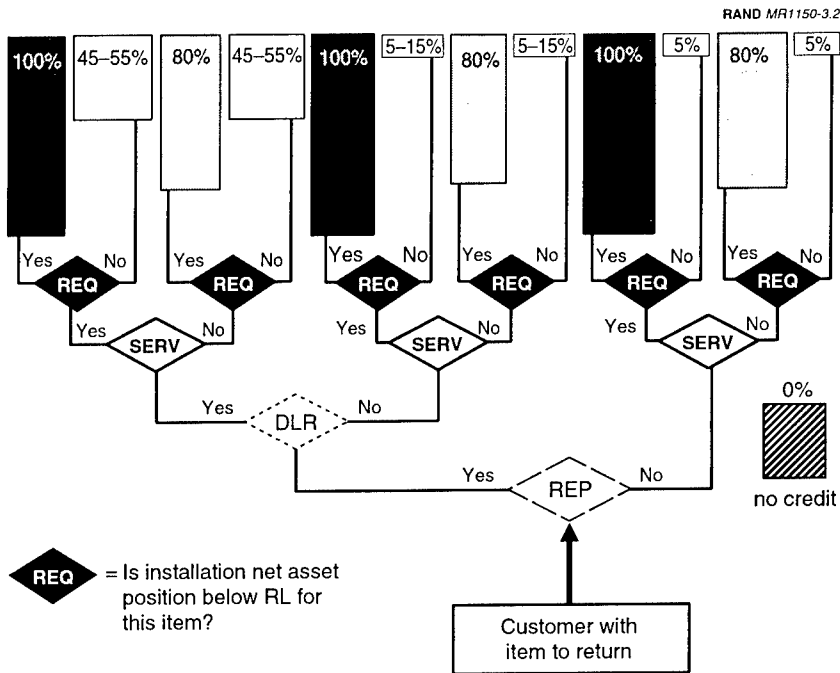

Figure 3.2—Credit Flow Chart⁶

⁶Figure 3.2 is based on a flow chart created by the Fort Campbell Directorate of Resource Management (DRM).

was required elsewhere on the installation (REQ); unfortunately, this factor was the most important in determining the credit as a percentage of the purchase price. Items that were obsolete or condemned (i.e., damaged beyond repair) received no credit, as indicated by the box in the lower right corner of Figure 3.2.

For example, a DLR or an FLR that was needed elsewhere on the installation got 100 percent credit if it was serviceable and 80 percent if it was unserviceable (assuming there was a repair program available on the installation or through ISM). However, if the same item was not needed, the customer got only 45–55 percent of the purchase price for a DLR or 5–15 percent for an FLR, regardless of its condition. Similarly, customers received 100 percent credit for a serviceable consumable if it was needed elsewhere on the installation but only 5 percent if it was not needed. Some items coded as consumables actually have GS-level repair programs, so customers may also have received credit for “unserviceable consumables.”

The effect of this policy on a particular item is shown in Figure 3.3. This example is drawn from financial data at Fort Campbell. The item represented is a receiver transmitter on the AN/ASN-86 inertial navigation set with a purchase price of \$2,340. All the returned items were serviceable. In October 1996, two transmitters were returned for full credit. On a single day in November 1996, five transmitters were returned, causing the installation’s NAP for this item to exceed the retention limit when the fifth transmitter was turned in. Thus, the SSA that turned in the last transmitter received only 52 percent credit, or \$1,123 less than expected based on the past credit rate. The NAP remained above the retention limit for the remainder of the period covered by the data.

The overall effect of basing credit on NAP was that customers could receive less credit on average for serviceable items than for unserviceable items, even though serviceable items should have a higher value to the Army. Figure 3.4 shows data from Fort Hood representing all returned items that received credit during a four-month period. The left panel shows the average percentage credit received for all serviceable and unserviceable items, followed by a breakdown into DLRs, FLRs, and consumables. For example, the first pair of bars shows that the average credit rate for all serviceable items returned was 20 percent of the AMDF price, whereas the average

RAND MR1150-3.3

NIIN 010121938 (receiver transmitter)
Price = \$2,340; serviceable

Date	Quantity returned	% Credit
16 Oct 96	2	100
22 Nov 96	4	100
22 Nov 96	1	52
20 Dec 96	4	52
4 Feb 97	5	52

} Same date
Different credits

Fort Campbell, STARFIARS October 1996 to January 1997

Figure 3.3—Credit Variability on a Single Item

credit rate for all unserviceable items was 44 percent. For each subcategory of items, the average credit rate for unserviceable items exceeded the average credit rate for serviceable items. The right panel shows that this situation arose because credit was based on the installation's NAP. When each category of items is subdivided into those that were required and those that were not required elsewhere on the installation, the bars reflect the credit policy shown in Table 2.1 and Figure 3.2. For example, the average credit rate for serviceable DLRs was 100 percent of the AMDF price if the item was needed on the installation, but only 52 percent if it was not needed.

This policy created financial incentives for OMA customers to set up alternative redistribution facilities for serviceable items rather than returning them to the supply system. Prior to SSF, most installations had OMA retention facilities that held items, particularly serviceable consumables, for a fixed period before returning them to the RSF.⁷

⁷Under SSF, these OMA retention inventories have been taken over and are being redistributed by the SSF. However, logistics customers can still redistribute items between OMA-funded SSAs reporting to the same SARSS CTASC.

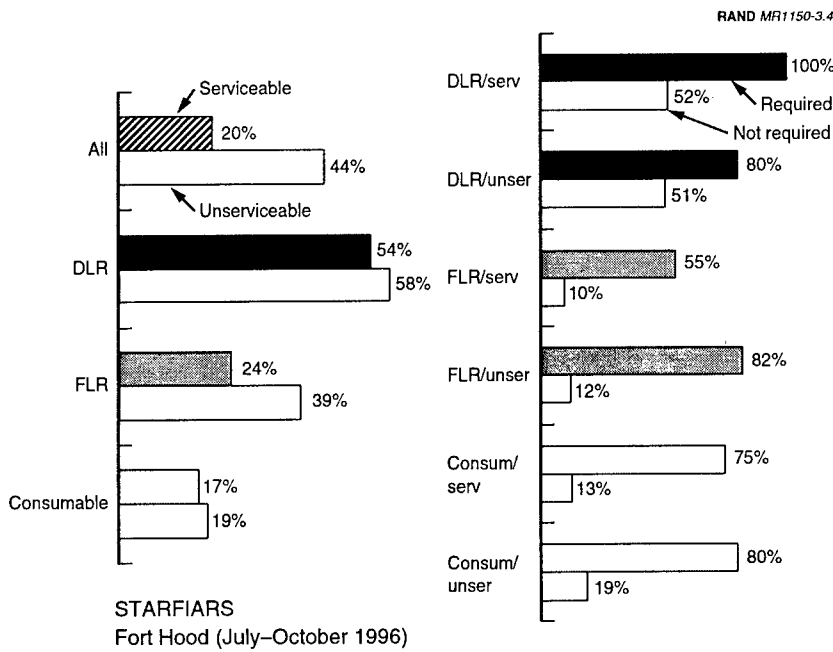

Figure 3.4—Average Credit Rates for Serviceable and Unserviceable Items at Fort Hood

If the item could be resold, the unit's or division's OMA account would not incur a loss on it. Otherwise, a serviceable consumable might be returned for 5 percent credit if it was not needed or not stocked on the installation, even though another unit (or the same unit) might have needed to buy it later and have to pay the full price. The Standard Army Retail Supply System (SARSS) was modified to allow redistribution of items between installations while they remain in OMA accounts.

To encourage customers to return items to the supply system instead of using alternative redistribution systems, credit should reflect the long-term value of the item to the Army, not the short-term value of the item on the installation. Since most serviceable items can be resold to other customers, credit should be set at the full value of the item, net of the costs of transporting and restocking the item. Simi-

larly, credit for unserviceable items should reflect repair, transportation, and restocking costs.

Surcharges

As discussed in Chapter Two, under the pre-SSF policy and current policy, the prices of Army-managed items are set at the LAC plus a supply management surcharge to recover the costs of operating the wholesale supply system.⁸ Even if the Army's LAC is low because it is able to make volume buys, the surcharge acts as a "tax" on purchases from the supply system. When items have commercial equivalents, OMA customers are likely to choose the least expensive source. Thus, even when the Army's acquisition cost is lower than local vendors' prices, a high surcharge may make local purchase the least expensive option. These diversions of purchases from the AWCF may cause it to recover less of its fixed costs. If the AWCF's actual sales volume is higher or lower than expected when the surcharge rate was calculated, the AWCF will either overrecover or underrecover any fixed costs included in the surcharge. Any gains or losses in the AWCF's annual accounts are reflected in future surcharges, so if high surcharges cause the AWCF to underrecover its costs and incur a loss, future surcharges are likely to be even higher.

An analysis of the supply management surcharge shows that it includes fixed costs that do not vary with supply management activity, costs that could be allocated more specifically to the items that generate them, and cash refunds that could be returned directly to OMA.⁹ Figure 3.5 shows the budget estimates for the Army's supply management surcharge for FY93 through FY00. We have highlighted the cost elements that could be funded by alternative mechanisms to improve customer decisionmaking. The costs shown in darker gray are not directly related to Army supply management activities. They include the costs of DoD agencies such as the Defense Logistics Ser-

⁸DLA and the other services set their own surcharge rates for the items they manage to recover their own supply system costs. Non-Army-managed items do not incur any additional surcharge from the Army.

⁹Although this categorization of surcharge costs is rough in the sense that some categories may mix fixed and variable costs, it provides a basis for a more accurate allocation of costs.

RAND MR1150-3.5

	FY93	FY94	FY95	FY96	FY97	FY98	FY99	FY00	Value in FY00
Supply Operations	457.1	396.9	351.2	447.8	461.0	391.6	387.8	388.1	
DISA						14.1	14.6	15.4	
DFAS	0.0	6.9	6.5	9.8	2.2	2.4	2.5	2.6	
DLSC/DAASO/DRMS	18.2	66.0	70.9	17.0	17.3	95.8	48.4	39.3	
Capital surcharge (JLSC/Army)	0.0	0.0	46.4	51.2	52.6	63.6	67.2	29.8	
Depreciation	8.0	14.1	12.9	13.1	12.0	18.0	20.7	22.2	
Annual operating result recovery	0.0	0.0	55.3	-5.1	-40.1	9.8	-4.0	27.2	136.5
Distribution depot	80.7	67.2	66.3	89.0	103.0	94.9	96.1	90.5	
Transportation	82.4	71.3	67.9	49.7	45.7	65.7	67.8	67.9	
Loss/obsolescence	81.6	0.0	34.7	33.7	46.8	42.5	40.0	37.9	
Safety of use/flight	0.0	17.8	17.3	16.9	16.6	25.6	23.8	22.7	
Mat'l inflation adj	73.4	0.0	97.2	101.2	66.4	39.7	32.0	40.4	259.4
Consumable item transfer refund	0.0	0.0	0.0	0.0	0.0	-68.3	-45.5	-33.3	
Cash adjustment	0.0	0.0	0.0	70.0	-229.4	-269.8	-69.0	-75.0	
Operations adjustment						-20.6	-7.4	-108.3	
Total	801.4	640.2	826.6	894.3	554.1	505.0	675.0	675.7	
Estimated sales (at LAC)	4077.8	3637.8	3473.0	3374.5	3318.2	2834.4	2668.9	2527.3	
Percentage of sales	19.7%	17.6%	23.8%	26.5%	16.7%	17.8%	25.3%	26.7%	15.4%

SOURCE: SMA Budget Estimates, FY93–FY97;
DALO-RMI briefings, FY98–FY00.

- Fixed costs
- Costs that could be allocated by item
- Cash that could be returned to OMA

Figure 3.5—Components of the Supply Management Surcharge (\$ million)

vices Center (DLSC), Defense Automated Addressing System Center (DAASC), Defense Reutilization and Marketing Service (DRMS), and Joint Logistics Systems Center (JLSC); depreciation; and adjustments for prior-year losses or gains. These costs could be funded by direct appropriations to avoid distorting customers' supply and repair decisions.¹⁰

The costs shown in lighter gray are those that vary on an item-by-item basis, such as depot storage and distribution costs, transportation costs, condemnation rates, or losses and obsolescence. For example, transportation costs are not a constant percentage of the purchase price of the item. Some expensive circuit cards could be relatively inexpensive to pack and ship, whereas inexpensive but heavy or bulky items could be relatively expensive to transport.

¹⁰It should be noted that the Army may need waivers from OSD or legislative approval to remove some of these costs from its supply management surcharge.

Therefore, these types of costs could be allocated to individual prices and credits on an item-by-item basis.

Components shown in black are short-term cash savings as a result of wholesale inventory reductions and transfers of consumable items to DLA management. Subtracting these one-time savings from the supply management surcharges causes prices and OMA budgets to fluctuate from year to year. It may also give customers the impression that supply management costs are falling faster than they actually are. After the inventory savings were realized in FY97 and FY98, for example, surcharges increased in FY99 and FY00. Taking these cash savings out of the stock fund and putting them into OMA budgets would make prices and OMA budgets more stable from year to year.

To give an idea of the magnitude of the costs that would need to be reprogrammed, we calculated the dollar value in each category of costs for FY00, shown in the last column on the right of the figure. The recommended changes would have involved \$136.5 million for direct funding of fixed costs, \$259.4 million allocated on an item-by-item basis, and \$108.3 million returned to OMA accounts. This would have resulted in a reduction in the surcharge from 26.7 percent to 15.4 percent in FY00. Extending these changes back to FY97–99 would have resulted in surcharges of 13.9 percent, 13.8 percent, and 14.5 percent, respectively, which would have been more stable than under current policy.

Pre-SSF credits given by the WSF to the RSF¹¹ and SSF credits are based on depot repair costs. Depot repair costs are based on depot maintenance hourly labor rates that also include fixed costs that do not vary with repair activity and costs that could be allocated on an item-by-item basis. Figure 3.6 shows the components of depot maintenance hourly rates in FY99 and FY00.

Fixed costs that (for the most part) do not vary with repair activity are highlighted in dark gray. These costs include Defense Information Systems Agency (DISA) and Defense Finance and Accounting Service (DFAS) bills, depreciation, rent, utilities, facilities maintenance, and

¹¹The pre-SSF WSF-to-RSF credits were averaged by MATCAT to calculate the RSF-to-OMA credit rates.

RAND MR1150-3.6

	FY99	FY00	Value in FY00	
	\$/hour	\$/hour	\$/hour	\$ million
Personnel expenses	\$44.99	\$48.04		
Materiel & supplies	27.92	35.38		
Equipment & maint	1.24	1.85		
Transportation	0.99	0.15		
Distribution depots	1.62	2.52		
Engineering support	0.81	0.03	\$39.94	\$455.9
Travel	1.88	0.90		
Printing & pubs	0.15	0.19		
DISA	0.57	0.68		
DFAS	0.21	0.16		
Other WCF support	0.63	1.23		
Depreciation	3.41	3.80		
Rents/leases	0.46	0.22		
Utilities	1.39	1.29		
Contractor facility maint	1.69	2.20		
Other purchased services	9.03	7.46		
Annual operating result recovery	0.61	-0.94		
Cash surcharge	8.00	6.70	\$23.90	\$272.8
Total	\$105.60	\$111.87		

Costs that could be allocated by item

Fixed costs

SOURCE: AMC-RM; AWCF FY00/01 Biennial Budget Estimates.

Figure 3.6—Components of Depot Maintenance Hourly Rates

prior-year gains or losses.¹² Fixed costs should be recovered through direct appropriations or lump-sum payments from customers. Variable costs that could be allocated on an item-by-item basis rather than on the basis of labor hours are shown in light gray. These costs include spare parts, supplies, transportation and distribution costs, and equipment and engineering support provided for specific types of items.

¹²Some proportion of these costs, such as utilities and facilities maintenance, could vary with maintenance activity and be allocated on an item-by-item basis using activity-based costing. The Army has used activity-based costing to develop installation cost maps for ISM and for the Service Based Costing system for installation support services. See Marygail K. Brauner et al., *ISM-X Evaluation and Policy Implications*, Santa Monica, CA: RAND, MR-829-A, 1997 and Michael J. Tsai and Peter Evanovich, *Evaluating the Use of Contractors for Installation Support Using Service Based Cost Data*, Alexandria, VA: Institute for Defense Analyses, 1999.

The last two columns in the figure show what the impact of reprogramming these costs would have been in FY00, based on an estimated 11,415,000 direct labor hours. \$456 million would have been allocated on an item-by-item basis, and \$273 million would have been directly funded. This reprogramming would have reduced the depot maintenance hourly rate from \$111.87 to \$48.04. These changes might also require relief from OSD policy.

Applying the Criteria to the Pre-SSF Policy

Figure 3.7 summarizes the application of the criteria introduced in Chapter Two to the pre-SSF policy. Plus signs indicate that, on balance, the policy satisfies the criterion; minus signs indicate that it does not. Although logistics customers were able to maintain expected OPTEMPO and the Army kept the AWCF in balance under pre-SSF budgets, prices, and credits, some features of the pre-SSF

RAND MR1150-3.7

Criteria for customers	Pre-SSF Policy
Maintain OPTEMPO	+
Local inventories sized to meet demands	-
Appropriate use of local purchase, redistribution, and local vs. depot repair	-
Reduce financial uncertainty	-
Criteria for suppliers	
Keep AWCF in balance	+
Reduce surplus inventories	-
Appropriate use of depot, contractor, and local repair	-

Figure 3.7—Application of Criteria to Pre-SSF Policy

policy created financial incentives for logistics customers and suppliers to make decisions that may not have been cost-effective from an Army-wide perspective.

Credit averaging often sends incorrect information to customers (at the division or installation level) about when to use local versus depot repair, and it can create incentives for customers to repair items in surplus at the national level, making it more difficult for suppliers to reduce surplus inventories. Basing credits on local need creates financial uncertainty and incentives for inefficient use of redistribution and makes it difficult for customers to adjust local inventory levels. The pre-SSF method of calculating surcharges (which remains essentially the same under SSF) creates incentives for inefficient use of local purchase and local versus depot repair by logistics customers, and it can give incorrect financial information to logistics suppliers about when to use depot, contractor, and local repair.

SSF PRICE AND CREDIT POLICY

As mentioned above, the Army has streamlined its logistics financial management system by implementing SSF. In the first phase of implementation, which is ongoing during FY01, the operations of the current RSF and WSF are being merged,¹³ and the SSF is also taking possession of inventories currently held in OMA-funded redistribution facilities. Since these installation-level inventories are visible to wholesale item managers, they can be redistributed among installations as needed.¹⁴ Repairs of installation-level inventories of RX and ISM items previously owned by the RSF have been brought under a National Maintenance Manager at AMC. Installations are being reimbursed for maintenance of SSF-owned items that they are designated to repair. In the second phase (called Milestone 3), division-level inventories (Authorized Stockage Lists, or ASLs) will be brought under SSF ownership.

¹³Since each installation has a branch of the RSF, new software must be installed at each installation to incorporate its RSF operations into the SSF. The software is being installed during FY01 according to a phased implementation schedule.

¹⁴The Army has set up a business unit to coordinate referrals of AWCF-owned items both locally and between installations..

The characteristics of the initial implementation of SSF are described in the Test and Evaluation Master Plan that was published in March 2000.¹⁵ The goals of the first phase are to establish a single point of sale, a single credit system, an integrated requirements determination system, and a national manager responsible for supply, maintenance and finance. SSF gives the Army's inventory managers greater visibility of wholesale and retail inventories and the ability to manage inventories centrally. As a result, the Army should be able to provide improved support to logistics customers at a lower cost through inventory level reductions, greater economies of scale in procurement and repair, and consolidation of activities.

SSF prices and credits are based on the prices and credits previously exchanged between the Army's WSF and RSF. Prices are set as under the pre-SSF policy, at LAC plus the supply management surcharge (i.e., AMDF price). Credits are set at LAC for serviceable returns and LAC minus item-by-item repair costs for unserviceable DLRs and FLRs,¹⁶ except for items that are not needed at the national level, which receive no credit.¹⁷ Credit for non-Army-managed serviceable consumables is set at 3 percent of the purchase price. Prices and credits will be adjusted annually and published in the AMDF and Federal Logistics Data (FEDLOG) catalogs.

Thus, the SSF price and credit policy corrects some of the problems associated with the pre-SSF policy, but it also raises some new issues.

¹⁵See <http://www.army.mil/ssf/tep/temp/temp.html>, "Single Stock Fund Milestone 1 and 2 Test and Evaluation Master Plan," Version 1, dated 16 March 2000, downloaded May 10, 2000.

¹⁶The repair cost for DLRs is based on the wholesale cost to repair the item, adjusted for washouts. The repair cost for FLRs is calculated using a weighted average of the wholesale repair cost and the installation repair cost, based on the current proportions of items repaired in each location, adjusted for washouts.

¹⁷According to the White Paper on FY01 Army Working Capital Fund, Supply Management Army (AWCF-SMA) Credit Table Policies and Procedures, "An item must be needed at the National level for inclusion as a creditable item. National need is determined by the National budget stratification process, which considers demand data and projected stockage levels for AWCF-SMA items." However, the definition of national need is not made explicit in the draft documentation for the SSF demonstration. National need is sometimes defined relative to the MRL, which is approximately seven years of supply at current demand rates, or to the wholesale Authorized Acquisition Objective (AAO), which is approximately two years of supply. Under SSF, however, WSF and RSF inventories and demand rates are being combined, which will result in a recalculation of desired inventory holdings.

In this section, we will discuss how the SSF policy addresses three issues similar to those discussed in relation to pre-SSF price and credit policy: credit averaging, basing credit on the Army's asset position, and surcharges.

Credit Averaging

Under the SSF price and credit policy, credits for Army-managed unserviceable items are based on item-by-item repair costs, adjusted for the replacement cost of items that cannot be repaired.¹⁸ Thus, in principle, the SSF credit policy should correct the problems described above that are associated with credit averaging. In practice, however, it appears that item-by-item repair costs and washout rates are not all being updated in the Army's wholesale logistics automated systems. Figure 3.8 shows all the nonzero unserviceable credit rates as a percentage of the purchase price for DLRs in MATCAT G, Electronics Materiel, from a CD-ROM of preliminary FY01 SSF prices and credits. The pattern was similar for other MATCATs.

Of the 26,625 items in MATCAT G, only 1,983, or 7.4 percent, had a nonzero unserviceable credit rate.¹⁹ Of the items receiving credit, 1,460, or 74 percent, had an unserviceable credit rate of 53 percent of the purchase price, and 135, or 7 percent, had an unserviceable credit rate of 29 percent. Across all MATCATs, 55 percent of the items with nonzero SSF unserviceable credits have an unserviceable credit rate of 53 percent and 10 percent have an unserviceable credit rate of 29 percent.

The SSF credit rates are based on overhaul costs recorded in the National Stock Number Master Data Record (NSNMDR), which in turn receives this information from the Maintenance Data Management System (MDMS). We checked the MDMS to find items with active depot repair programs and found that 37 percent of these items had a recorded depot overhaul cost of 26 percent of the pur-

¹⁸As mentioned above, the formula for the unserviceable credit rate is $LAC - (1 - \text{washout rate}) \times (\text{repair cost}) - (\text{washout rate}) \times LAC$.

¹⁹The large number of items getting no credit is due to the policy of basing credit on national need, i.e., the Army's asset position, which is discussed below.

RAND MR1150-3.8

MATCAT G: Communications and Electronics Equipment, Electronics Materiel
Only Class IX DLRs

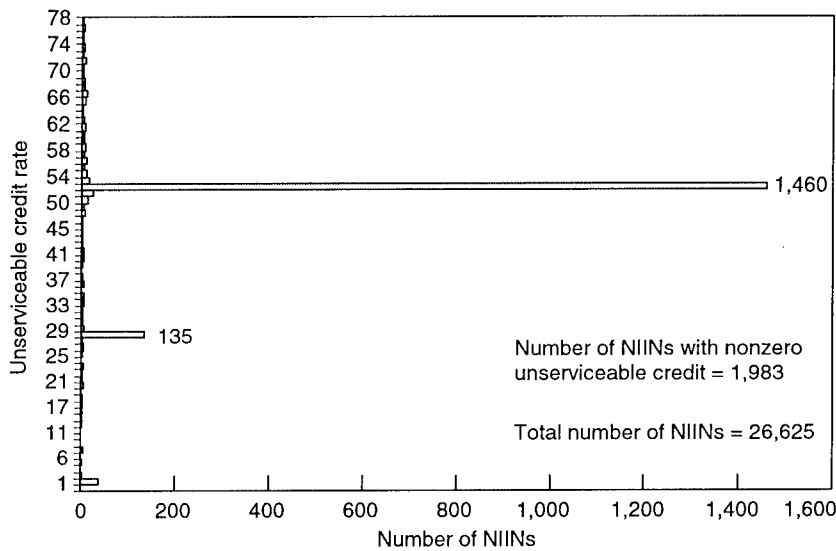

Figure 3.8—SSF Unserviceable Credit Rates as a Percentage of Purchase Price

chase price. Thus, it appears that the most likely explanation for the large numbers of items with the same unserviceable credit rate is that when new items enter service, the wholesale data systems are initially populated with a “default” overhaul cost set as a percentage of the acquisition cost. When actual repair data become available, some overhaul costs are updated, but a large proportion are not.

Therefore, in practice, many unserviceable credit rates are still based on averaged repair costs because actual repair costs are not correctly recorded in wholesale logistics information systems. In addition to their effects on repair decisions made by OMA customers at the division level, the use of default values for depot overhauls costs may distort estimates of SSF savings and could affect wholesale repair decisions. For example, the SSF national maintenance manager may not be able to make cost-effective choices between wholesale and

installation repairs or between organic maintenance facilities and contractors.

Basing Credits on Army Asset Position

Under SSF price and credit policies, credits for Army-managed items depend on the national need, or the Army's asset position, rather than the installation's asset position, and will be adjusted yearly rather than on a potentially daily basis. Credits for non-Army-managed items are set at 3 percent of the purchase price. Therefore, much of the uncertainty in the pre-SSF credit policy is eliminated under SSF. However, OMA customers are getting little or no credit for many more items than under the pre-SSF policy, since they previously got averaged credit rates for DLRs not needed locally and could get 100 percent credit for non-Army-managed serviceable items if they were needed locally.²⁰

Because of the force drawdown, process improvements in wholesale supply management, and changes in inventory modeling assumptions,²¹ inventories of more DLRs are likely to be surplus to national need than in the past. Thus, the zero credit policy may come into effect for more items under SSF than it did under the pre-SSF WSF-to-RSF credit policy.

From the perspective of AWCf managers, a policy of giving no credit for items in long supply is thought to help reduce wholesale invento-

²⁰An analysis of all class IX (i.e., spare parts) DLRs that were ordered in FY98 SARSS CTASC data found that 34 percent of them would get no credit for serviceable returns and 62 percent would get no credit for unserviceable returns, based on preliminary FY01 SSF credits. However, credits are increasing for some items, such as serviceable DLRs needed at the national level. In aggregate, logistics customers should be able to order and return the same items in the FY98 SARSS CTASC data with the same total OMA budget as under pre-SSF policy, but the effects vary between installations. Some installations would need a higher OMA budget to cover the same purchases and returns as in FY98, but others would need fewer OMA funds.

²¹Some AWCf managers favor basing national need on the AAO (two years of supply) rather than the MRL (seven years of supply). In FY99, AMC implemented the "decline level" computed by its economic retention model. The decline level sets a limit over which it is judged uneconomical to pay the transportation and processing costs associated with returning an asset to a wholesale depot. Implementing the decline level thus had the effect of increasing the number of items getting no credit from the WSF.

ries by discouraging returns. This policy might also improve the balance of the AWCF, since it would be giving credit for fewer items and would not incur the cost of providing credit for items it was unlikely to resell. But from the perspective of OMA customers, getting little or no credit increases the net price of a purchase accompanied by a return. This is likely to make it difficult for OMA customers to maintain OPTEMPO, unless OMA funding is increased to account for the higher net price of items surplus to national need. It will also become more expensive to adjust local OMA-funded inventories to reflect demands if some items get little or no credit. In addition, OMA customers are likely to make greater use of other sources of supply and repair, such as local purchase, lateral redistribution,²² and OMA-funded repair, for items getting little or no credit. As a result, both purchases and returns of items in surplus are likely to fall.

This policy has an ambiguous effect on wholesale inventories and stock fund solvency, because reduced returns and credits may be offset by reduced purchases and sales revenue. For items with a surplus of serviceables, installations may repair unserviceables locally rather than purchasing serviceables from the supply system, thus raising total costs to the Army. For items with a surplus of unserviceables, OMA customers may stop returning serviceables, causing the Army to incur the cost of repairing unserviceables in wholesale depots to meet demands if serviceable inventory in ASLs is not visible to the AWCF.

For example, the left-hand side of Table 3.3 shows several DLRs and one FLR for which the RSF received no credit from the WSF (under pre-SSF policy) and for which OMA customers get no credit under the SSF credit policy. Column 4 indicates the amount of serviceable inventory available to meet annual demands, shown in column 5.²³ Column 6 shows the serviceable returns that were available to fill

²²Under the first phase of SSF, the AWCF took over installations' OMA-funded redistribution facilities, so these facilities are longer available for OMA-to-OMA redistribution. However, the Army has liberalized retention policy for Supply Support Activities (SSAs), so more items may be held in these inventories for OMA-to-OMA redistribution. When customers create alternative distribution systems, the Army's total logistics costs are likely to increase, and order-and-ship times are typically longer.

²³These items can be considered to be surplus to national need even if demands are greater than serviceable inventories, if there is a surplus of unserviceables.

Table 3.3
Zero Credit for Items in Surplus Can Increase Repair Costs

(1)	(2)	(3)	(4)	(5)	(6)	(7)	(8)
NIIN	Description	Type	Serviceable Inventory	Demands	Serviceable Returns	Demands that must be filled by repair or procurement	Repair Cost
14503535	Stat Power Inverter	DLR	11	66	0	55	\$6,125
14458101	Fault-Function Panel	DLR	0	2	0	2	2,640
14426929	Valve Assembly	DLR	0	13	4	9	1,693
14397273	Fire Computer	DLR	5	11	1	5	27,943
14396663	Television Camera	DLR	24	39	1	14	11,028
12219123	Disc Drive	DLR	4	10	1	5	2,302
11997646	Controller Swashplate	DLR	12	36	6	18	5,500
11429546	Target Range Finder	FLR	21	29	5	3	2,173

demands. Column 7 is the difference between annual demands and the sum of serviceable inventory and returns. Depot-level repair costs for each item are shown in the column 8. To meet the demands in column 7, the AWCF must incur either repair or procurement costs, because customers are unlikely to return serviceable assets if they are getting no credit. Thus, a policy of giving no credit for items that are surplus to national need can increase total costs to the Army.²⁴

The first DLR in Table 3.3 is a good example. If OMA customers had serviceable items to return, the AWCF could give credit for these items equal to the cost of the item less a surcharge for transportation and restocking; then, the AWCF could sell them to other customers for full price. Thus, the AWCF would not only cover its cost of transportation and stocking but would also avoid the \$6,125 repair cost or an even higher procurement cost.

Continuing credit for unserviceable items that are surplus to national need may also be cost-effective if centralized management of unserviceable assets reduces total repair costs. Without credit, installations may begin to repair assets locally or dispose of unserviceable assets that (1) can be returned to serviceable status at significantly lower cost than items currently stored in wholesale depots (particularly those that have been held for long periods in exposed storage) or (2) are actually serviceable but are returned as unserviceable because of less sophisticated diagnostic equipment available in the field (e.g., particularly true of high-value electronics). There could also be some potential for disassembly and reuse of subcomponents of the unserviceable items in surplus, which would be lost if items are disposed of locally.

From FY95 through FY99, the Army used the Reduced Price Initiative (RPI) to lower the prices of some items in surplus at the wholesale level.²⁵ The RPI is no longer in effect under the SSF price and credit policy. In principle, the RPI can be an effective policy for reducing surplus inventories by helping ensure that OMA customers buy

²⁴Credits given from the AWCF to OMA customers are simply accounting transactions, whereas repair and procurement are real costs to the Army.

²⁵See the Appendix for more details on the history of the RPI and the proposed FY00 RPI policy, which was not implemented.

excess serviceable items from the supply system instead of repairing unserviceable items. In practice, however, the prices of many RPI items were set somewhat arbitrarily rather than in relation to actual repair costs. For example, the prices of many items were reduced to the surcharge rate applied to their LAC, i.e., 15–25 percent of their previous price. When prices were lowered so dramatically, “surplus” inventories of some items were depleted so quickly that supply managers had to initiate emergency repairs or procurements. To implement the RPI more effectively, the Army should set prices in relation to local repair costs and ensure that there are enough serviceable assets in supply to meet demands over the lifetime of the weapon system, even if demand rates increase in response to the lower price. Otherwise, the AWCF risks running out of serviceable assets without having raised sufficient funds to repair any unserviceable assets in stock or procure replacements.

Surcharges

Although one of the alternative price and credit policies for SSF proposed direct funding of fixed costs currently included in the supply management surcharge, it was not adopted because of problems with other aspects of the policy.²⁶ Thus, the same cost factors are included in the supply management surcharge and in depot maintenance hourly rates as under the pre-SSF policy. However, the surcharge costs can now be spread over the combined WSF and RSF sales of Army-managed items, so the percentage surcharge rate may be reduced. Similarly, ISM and RX programs formerly operated through the RSF have been brought under a national maintenance manager; this could result in some workload being transferred to the wholesale maintenance depots. Fixed costs might then be spread over a larger depot maintenance workload, resulting in lower hourly rates. Thus, although the distortions in financial incentives caused by surcharges may be reduced under the SSF price and credit policy, they will not be entirely eliminated.

²⁶See the discussion of Alternative 3 in Marygail K. Brauner et al., *Evaluating Five Proposed Price and Credit Policies for the Army*, Santa Monica, CA: RAND, DB-291-A, 2000.

RAND MR1150-3.9

Criteria for customers	Pre-SSF Policy	SSF Policy
Maintain OPTEMPO	+	+
Local inventories sized to meet demands	-	+/-
Appropriate use of local purchase, redistribution, and local vs. depot repair	-	+/-
Reduce financial uncertainty	-	+

Criteria for suppliers	Pre-SSF Policy	SSF Policy
Keep AWCF in balance	+	+
Reduce surplus inventories	-	-
Appropriate use of depot, contractor, and local repair	-	+/-

Figure 3.9—Application of Criteria to SSF Policy

Applying the Criteria to the SSF Policy

The initial SSF price and credit policy is an improvement over the pre-SSF policy in most respects, but as noted above, there are some problems remaining. Figure 3.9 shows the application of the price and credit criteria to the SSF policy. (The designation +/- indicates that the policy satisfies the criterion in some respects, but not in others.) In aggregate, the SSF policy requires approximately the same OMA budget as the current policy, assuming demand and return rates remain constant. Thus, customers should be able to maintain their planned OPTEMPO, and suppliers should be able to keep the AWCF in balance if customer behavior does not change. However, the SSF policy affects some installations differently from others, and demand and return rates could change in response to SSF price and credit changes, so OMA budgets and the AWCF cash balance should be carefully monitored in case adjustments are needed.

Item-by-item credits for unserviceable reparable and increased credits for serviceable reparable should reduce inefficient use of redistribution and local repair by customers, and make it easier for customers to rebalance inventories of these items. Basing credits on the Army's asset position instead of the installation's asset position will greatly reduce financial uncertainty. However, giving little or no credit for non-Army-managed consumables and items in surplus, basing many item-by-item repair costs on default values, and keeping the same cost elements in surcharges will continue to give incorrect financial information to customers about when to use local purchase, redistribution, and local versus depot repair, and make it difficult to rebalance inventories of items getting low credits.

For logistics suppliers, the National Maintenance Manager should be somewhat better able to compare local versus depot repair, but the use of default values for depot repair costs and the allocation of costs to depot maintenance hourly rates make it difficult to compare depot repair costs with contractor and local repair. Reducing credits for items that are surplus to national need may increase financial incentives for local repair and redistribution of these items, thus reducing the rate at which surplus inventories are sold to customers.

"FUTURE" PRICE AND CREDIT POLICY

In the Army financial management community there has been recent discussion of a further price and credit policy change to be effective in the second phase of SSF, when ASLs will be incorporated into the AWCF. One proposal is to redefine the price as a weighted combination of the acquisition cost and the repair cost, with the weights depending on unserviceable return rates and washout rates. Since these prices are likely to be lower than current prices, which are based on LAC, the supply management surcharge would be a higher percentage of the price, although the types of costs included in the surcharge would be similar. Under this proposal, a nominal credit of approximately 10 percent of the proposed price (including surcharge) would be used "to encourage carcass return."²⁷

²⁷See, for example, DALO-RMI, "Credit/Pricing Policy," briefing to Single Stock Fund General Officer Working Group, December 14, 1998, downloaded from <http://www.army.mil/ssf/briefings/gowg-dec98/gowg-dec98.html>.

The motivation for this proposal is to keep the costs for requisitions with returns roughly equal to current costs and to drastically reduce credit. However, the proposal is based on two common mistaken assumptions: (1) purchases of reparable items are always accompanied by returns and (2) eliminating credits would eliminate incentives for logistics customers to behave “entrepreneurially,” i.e., to divert transactions from the wholesale supply system to other sources of supply and repair. We look at each assumption separately.

Assumption 1: All DLR and FLR Transactions Are Exchanges

Army supply transactions can be classified into four types:

1. *Requisitions with returns.* For reparable items (DLRs and FLRs), many supply transactions are exchanges—purchasing a working item and returning an unserviceable one.
2. *Requisitions without returns.* When equipment changes or stock levels and inventories are adjusted, customers may buy items without a return. Of course, consumable requisitions should not be accompanied by a return.
3. *Serviceable returns.* When equipment changes or stock levels and inventories are adjusted to reflect changing demand patterns, customers may return serviceable items.
4. *Unmatched unserviceable returns.* Customers may also return unserviceable items without buying a serviceable item of the same type when making changes in local inventory.²⁸

As mentioned earlier, the Army’s TRM, which is used to develop OMA budgets for operating units, assumes that all supply transactions for reparables (both DLRs and FLRs) are exchanges, i.e., requisitions with returns. For consumable items, the TRM assumes that all supply transactions are purchases of new items.²⁹ In a perfect,

²⁸Under pre-SSF credit policy, customers could receive credit for unserviceable consumables. Some may have contained precious metals or may have had local repair programs, even though they are catalogued as consumables. We reclassify “reparable consumables” as FLRs in the analysis below.

²⁹See, for example, U.S. Army Cost and Economic Analysis Center, “Resourcing Army Training,” briefing to the Credit and Pricing Integrated Product Team, March 24, 1998.

steady-state world, reparables should only be purchased when a similar item is broken and needs to be replaced, and consumables are only purchased when needed to complete a repair.

In practice, however, OMA customers make many unmatched purchases and unmatched returns of both serviceable and unserviceable reparables, and they return many unused consumables. Unmatched purchases and returns occur for many reasons, including equipment changes, local inventory changes in response to changing demand rates, incorrect diagnosis of maintenance problems, and ordering errors.

An analysis of FY98 Army supply data³⁰ shows the dollar value of each type of transaction (evaluated at LAC) between OMA customers and the stock fund. As seen in Figure 3.10, the dollar value of DLR requisitions with returns³¹ was just slightly greater than the dollar value of requisitions without returns. The dollar value of DLR serviceable returns almost equaled the dollar value of unmatched DLR unserviceable returns.

The patterns were very different for FLRs and consumables. The high dollar value of FLR requisitions with returns probably results from the ISM³² and RX programs. When an item was on the installation's RX list or in the ISM program, the customer returned an unserviceable FLR and received a serviceable one in return. For con-

³⁰As part of previous analysis, we assembled FY98 supply data on all transactions recorded at 11 SARSS Corps-Theater Automated Data Processing Service Center (CTASC) sites. The commands represented include FORSCOM, TRADOC, USAREUR, EUSA, and two Army Reserve sites. However, data from TRADOC were incomplete because many installations did not convert to SARSS until late in the fiscal year. See Marygail K. Brauner et al., *Evaluating Five Proposed Price and Credit Policies for the Army*, Santa Monica, CA: RAND, DB-291-A, 2000, for a more complete description of these data.

³¹The analysis matched requisitions and returns by National Stock Number (NSN) and installation. When there was a requisition with no corresponding unserviceable return, the transaction was classified as a requisition without a return at that installation. When there was an unserviceable return with no corresponding requisition, the transaction was classified as an unserviceable return at that installation.

³²The ISM program allowed customers to return an unserviceable FLR to a designated Center of Excellence (COE) for repair; the COE repaired the item and returned it to the customer. Most COEs are located in installation GS maintenance facilities. Under SSF, COEs have been incorporated into the National Maintenance Management program.

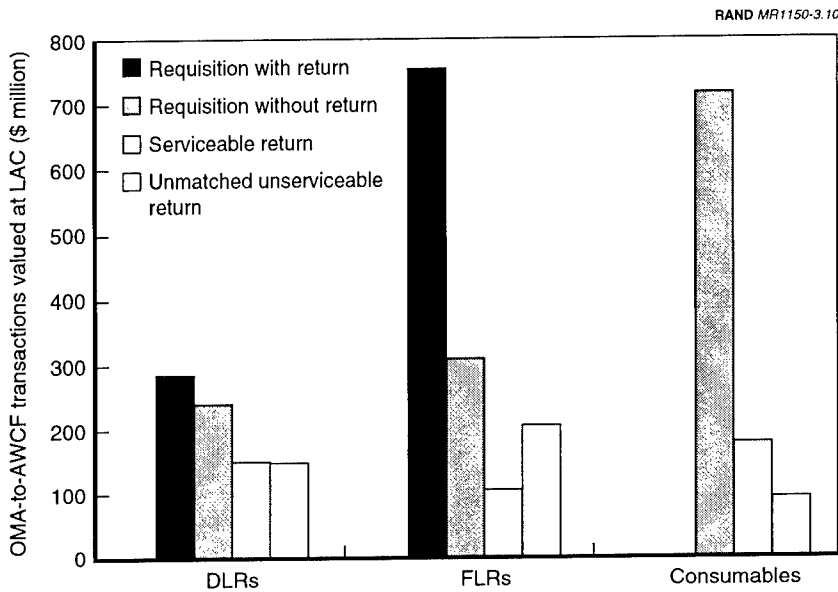

Figure 3.10—Army Supply Data Show Significant Numbers of Unmatched Purchases and Returns

sumables, most transactions are requisitions without returns, as expected. However, there are also significant numbers of serviceable and unserviceable returns recorded in the supply system.

Since the proposed policy reduces prices for all DLR and FLR requisitions, it would drastically reduce the revenue to the AWCF for requisitions without returns. If the proportion of requisitions without returns rises, this could mean that the AWCF would not have enough funds to cover the cost of procurement of replacement items, particularly if lower credit rates also reduce unmatched returns.

Assumption 2: Eliminating Credits Would Eliminate “Entrepreneurial” Behavior

The proposed policy provides nominal 10 percent credit. The use of such a nominal credit is based on the assumption that eliminating credit would eliminate customer incentives to “game” the logistics

system to save OMA logistics funds that can be spent on other activities, such as base operating support. But from the customer's point of view, credits are simply one part of the OMA budget that must be allocated to training, spare parts, civilian employees, and other OMA-funded activities. In fact, the OMA customer's budget is predicated on the receipt of expected flows of credit, so eliminating credit would require an increased OMA budget, unless prices were also reduced. Furthermore, credit creates a financial incentive to return items that are no longer needed and could potentially be used by other customers. Reducing credit may increase the customer's financial incentive to repair items locally and to redistribute items rather than returning them to the supply system when these actions are not cost-effective from an Army perspective.

Figure 3.11 is a simplified depiction of cash flows for Army-managed DLRs to illustrate the dependence of OMA customers on credit flows. If an operating unit is expected to purchase \$200 million of DLRs, it is given an OMA budget of approximately \$100 million. When it spends this \$100 million on DLRs, approximately \$20 million (20 percent) is taken out for the Supply Management surcharge, which funds the operating costs of the wholesale supply system. Roughly \$30 million (30 percent) on average is used to fund repair (or replacement of washouts), and approximately \$50 million (50 percent) comes back to the OMA customer as credits, assuming that an unserviceable carcass is returned for each item bought. This first round of cash flows is shown in gray.

The OMA customer can then spend the \$50 million in credits on another round of DLR purchases, of which approximately \$10 million pays the surcharge, \$15 million pays for repairs, and \$25 million is returned as credits (shown in white). The \$25 million in credits pays for yet another round of DLR purchases (shown in black).

If we sum up all these flows, by the end of the fiscal year, the operating unit is able to spend a total of \$200 million on DLRs, even though it only started with a \$100 million budget. Of its original \$100 million, \$40 million is used to cover supply system operating costs and \$60 million is used to pay for repairs. The additional \$100 million of expenditures is generated through credits.

As an extreme example, suppose that under a new price and credit policy, no credits—as opposed to the 10 percent credit in the pro-

Purchases: $\$100m + \$50m + \$25m + \dots = \$200m$

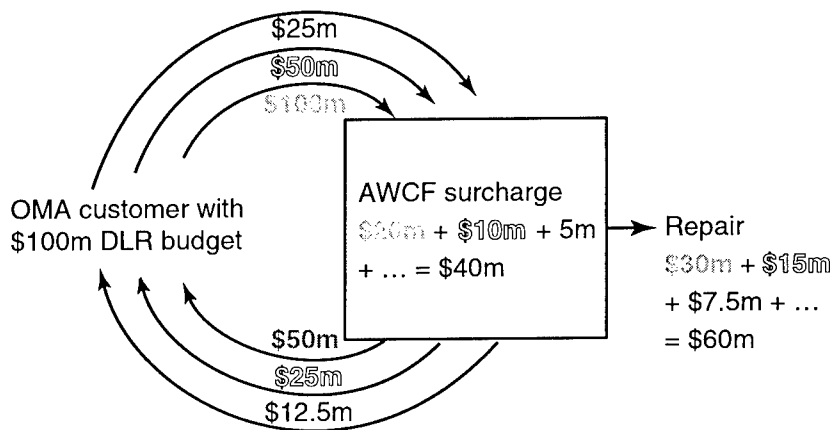

Credits: $\$50m + \$25m + \$12.5m + \dots = \$100m$

Figure 3.11—OMA-Funded Customers Depend on Credit Flows to Continue Purchasing DLRs

posed policy—were issued to customers, but prices and OMA budgets stayed the same. Figure 3.12 shows the results. Of the operating unit’s initial \$100 million in expenditures, approximately \$20 million goes into the Supply Management surcharge, and \$30 million is used to pay for repairs. The remaining \$50 million is trapped in the stock fund. Some of this \$50 million may be needed to pay for supply or repair costs, if there were not enough transactions to cover fixed costs. (For example, repair facilities would have their workload and funds reduced from \$60 million to \$30 million unless additional funds were transferred.) The remainder is recorded as profits to the stock fund, and cannot be returned to OMA customers until the next budgeted fiscal year, which is typically a two-year lag.

As a result, the operating unit will only be able to buy \$100 million worth of DLRs, half of what it was previously able to buy. Thus, the unit is likely to find it difficult to maintain OPTEMPO and equipment readiness.

RAND MR1150-3.12

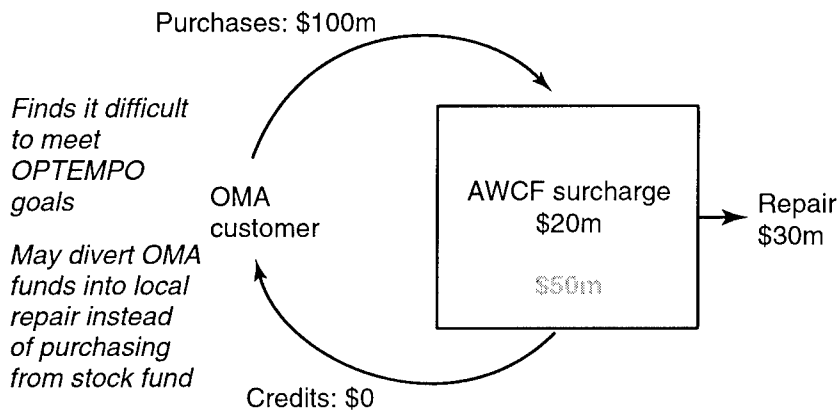

Figure 3.12—Without Credits, There Are Fewer Sales from the AWCF to the OMA Customer

In the case of the proposed policy, it is doubtful that customers would return serviceable items for only 10 percent credit. Thus, customers would have an increased financial incentive to divert some of their OMA funds into local purchase or redistribution for serviceable items to stretch their buying power. Unserviceable returns could also be affected by low credit rates if they could be repaired locally for less than 90 percent of the reduced price or disassembled and used as a source of subcomponents. Thus, only unserviceable items that are expensive to repair or in very bad condition would be returned to the supply system, causing an increase in average repair costs.³³ If return rates fall and average repair costs increase as a re-

³³It has been argued that under SSF all repairs will be controlled by the AWCF; thus, there will be no incentive to keep unserviceable items. We would point to the ISM program and FORSCOM Materiel Management Center (FMMC) as examples where repair was "purchased" outside of the AWCF at lesser cost to the customer. Furthermore, many Army reparable items have commercial equivalents and can be repaired by local vendors. The only way the Army can assure that customers will use AWCF repair is to price that repair competitively.

The Air Force keeps most local inventories in the Air Force Working Capital Fund (AFWCF), but customers are able to use O&M-funded intermediate repair facilities and local vendors to repair some items or to test electronic components with high NEOF (no evidence of failure) rates.

sult of changes in customer behavior, prices will also have to increase to keep the AWCF in balance.

In addition to changing the financial incentives for repair and redistribution, reducing or eliminating credit is likely to make it difficult for logistics customers to achieve their missions, unless OMA budgets are increased or prices are reduced.

Applying the Criteria to the “Future” Price and Credit Policy

Because the proposed future price and credit policy described above is based on these two misconceptions, it is unlikely to perform well under the criteria introduced in this report, as shown in Figure 3.13. (A double minus indicates that the policy is worse than the pre-SSF policy in satisfying the criterion.) Drastically reducing credit may make it difficult for logistics customers to maintain OPTEMPO without a higher budget. Customers are likely to find it difficult to adjust inventory levels and to turn to local repair, local purchase, and redistribution when it is not cost-effective from an Army-wide perspec-

RAND MR1150-3.13

Criteria for customers	Pre-SSF Policy	SSF Policy	“Future” Policy
Maintain OPTEMPO	+	+	-
Local inventories sized to meet demands	-	+/-	--
Appropriate use of local purchase, redistribution, and local vs. depot repair	-	+/-	--
Reduce financial uncertainty	-	+	+

Criteria for suppliers	Pre-SSF Policy	SSF Policy	“Future” Policy
Keep AWCF in balance	+	+	-
Reduce surplus inventories	-	-	-
Appropriate use of depot, contractor, and local repair	-	+/-	-

Figure 3.13—Application of Criteria to “Future” Policy

tive. However, financial uncertainty would be reduced, since credits would not depend on the installation's asset position.

Since prices are the same for requisitions with and without returns, return rates may fall, leaving the AWCF without enough funds to procure replacement parts. Repair costs could also increase if only items in the worst condition are returned. Reducing credits is unlikely to reduce surplus inventories, since it increases customer incentives for local repair and redistribution of these items. In addition, the "future" policy would not improve the financial information available to logistics supply managers about when to choose local, depot, or contractor repair.

This evaluation of "future" policy illustrates that it is important to avoid both of these misconceptions when considering reforms to the Army's price and credit policies for spare parts. First, a well-designed price and credit policy must address all four types of transactions: requisitions with returns, requisitions without returns, serviceable returns, and unmatched unserviceable returns. Second, substantially reducing or eliminating credits will restrict the funding available to operating units to achieve their missions, in addition to changing the financial incentives to make unmatched returns.

In general, policies that set prices and credits to reflect the actual costs incurred by the logistics system and the values of serviceable and unserviceable assets promote cost-effective behavior by OMA customers. Such policies also require fewer adjustments and rules to cope with entrepreneurial behavior that is not cost-effective from a global Army perspective. The best policy is for customers to pay the actual costs of repair, transportation, storage, distribution and procurement, allocated to the items or activities that generate them as accurately as possible. When pricing policies deviate from actual costs, entrepreneurial activities that are not cost-effective from an Army perspective, such as alternative repair and redistribution facilities, spring up to take advantage of discrepancies. Unfortunately, this proposed future price and credit policy moves away from the goal of prices and credits that reflect the actual costs of the logistics system and is likely to result in more inefficient entrepreneurial behavior rather than less.

In the final chapter of this report, we discuss the characteristics that an optimal Army price and credit policy should have.

**CHARACTERISTICS OF AN OPTIMAL
PRICE AND CREDIT POLICY**

The purpose of the Army's price and credit system is to maintain readiness at lower total cost by creating financial incentives for logistics providers to reduce costs and for logistics customers to use resources cost-effectively. In general, these objectives are best achieved when prices and credits reflect the variable costs of each type of transaction as accurately as possible. Fixed costs, or costs that do not vary with transactions, should be recovered through lump-sum payments from customers (or direct appropriations) rather than through surcharges, which inflate the cost of each transaction and may cause customers to seek other sources of supply and repair.¹

When prices, credits, and other payments are set to reflect total costs as described above, logistics providers will receive the funds they need to cover their costs, and logistics customers will receive correct information about the costs of the Army's wholesale logistics services for comparison with their own costs or the costs of local vendors. The Army will also have more accurate information about the costs of organic logistics providers to compare with contractors' costs for direct vendor delivery or depot-level repairs.²

¹These recommendations are consistent with the business management literature on internal pricing mechanisms, also called "transfer pricing." See, for example, Eccles (1991), Halal (1994), Harris, Kriebel, and Raviv (1982), and Hirshleifer (1956). Another example of the problems created when transfer prices do not accurately reflect costs is given in Kovac and Troy (1989).

²When the Army is considering whether to purchase depot-level repairs from contractors or from organic maintenance depots, it should only consider the costs that change as a result of the repair decision. If depot fixed costs are truly fixed, i.e., they

In this chapter we discuss how this principle can be applied to the Army's price and credit policies, and how the resulting policies satisfy the criteria described in Chapter Two.³

PRICES

Under the pre-SSF and SSF price and credit policies, prices are set at LAC plus a supply management surcharge used to recover a variety of fixed and variable costs of the wholesale supply system. As discussed in Chapter Three, OMA customers would get more accurate information about the cost of items if the variable costs included in the surcharge (such as storage, distribution, and transportation costs) were allocated on an item-by-item basis, and if the fixed costs included in the surcharge were funded either through direct appropriations or a lump-sum payment, perhaps assessed at the MACOM level in proportion to each MACOM's (or other customer's) use of the wholesale supply system.

As a hypothetical example of reallocating variable costs, consider a small, lightweight circuit card with an acquisition cost of \$1,700 and a landing gear wheel, which is larger and heavier but has an acquisition cost of \$450. Distribution depot obligations (storage and distribution costs) account for 3.6 percent and transportation obligations account for 2.7 percent of the total FY00 surcharge of 26.7 percent. Thus, OMA customers are charged \$107.10 in storage, distribution, and transportation costs for the circuit card and \$28.35 for the landing gear wheel, when actual costs are likely to be lower for the circuit card and higher for the wheel. These costs could be more accurately allocated based on the weight and volume (or "cube") of the item, which are available in the AMDF catalog, as well as on other factors, such as indoor versus outdoor storage or special handling require-

do not vary with repair decisions, then it is appropriate to compare the marginal costs of organic depot repairs with the prices charged by contractors for the same repairs, even when contractors' prices include fixed costs. The Army cannot "save" depot fixed costs by sending repairs to a contractor. If it is possible to reduce depot capacity by using contractors, then those capacity costs are not fixed, and they should be considered in the repair decision.

³Analysts who have studied the Air Force and Navy Working Capital Fund price and credit systems have made similar recommendations. See, for example, Baldwin and Gotz (1998), Rogerson (1995), Trunkey and Choi (1996), and Wallace, Kem, and Nelson (1999).

ments. Other costs that could be more accurately allocated on an item-by-item basis include loss and obsolescence, safety of use or flight testing, inflation adjustments, and possibly some item management costs.

More detailed cost accounting methods, such as activity-based costing, could be used to identify and allocate variable costs on an item-by-item basis and to identify costs that are truly fixed in the sense that they do not vary either directly or indirectly with the number of transactions. Since the remaining fixed costs will be recovered as direct appropriations or as lump-sum payments, it is important that they are truly fixed costs; otherwise, logistics providers could either underrecover or overrecover their costs if they are allocated incorrectly. Furthermore, the wholesale supply system's fixed costs should remain visible to customers (at the MACOM level, for example) so that logistics providers will have an incentive to reduce fixed costs through process improvement.

The Army might also want to consider changing the use of LAC as the basis for prices. As a result of this policy, whenever a procurement occurs, the Army's entire inventory of the item is revalued at the new acquisition cost, which is likely to be higher (but could be lower) than the actual cost of many of the assets. Depending on the characteristics of the item, a newly bought item may be more valuable than an older item that has been repaired or overhauled several times. Therefore, rather than basing all prices on the LAC, the Army may want to base some prices on a weighted average of current and previous acquisition costs or on the condition of the item (new versus rebuilt).

If the Army sets prices to reflect acquisition, transportation, and stocking costs more accurately, it will be cost-effective from the local perspective for OMA customers to use local vendors as a source of supply only when it is also cost-effective from the Army perspective, taking both cost and responsiveness into account.

Exchange Pricing

The Army could reduce financial uncertainty and the number of financial transactions by using an exchange price system. Under an exchange price system, OMA customers pay the difference between

the price and the credit when a purchase is accompanied by a return.⁴ If the carcass is not returned within a fixed time limit (60 days, for example), the customer is penalized the amount of the credit. OMA customers can also receive credit for unmatched returns or pay full price for a purchase without a return.

Both the Navy and the Air Force currently use exchange pricing for their DLRs, and it is mandated by current OSD policy.⁵ The Army must annually request a waiver from this policy. The primary concern of the Army is that it lacks a system for tracking carcasses that would allow it to penalize units that fail to return carcasses within the allotted time. However, the Army is currently making efforts to add the capability to track unmatched returns to new systems, such as the Integrated Logistics Analysis Program (ILAP). This capability could be used to help implement an exchange price system.

Under the current system of separate price and credit transactions, customers must have enough funds in their OMA accounts to pay the entire purchase price of the item and then wait for the credit to appear in their financial records after they return the matching carcass. Delays in receipting and financial processing can generate uncertainty about the amount of OMA funds available to the customer, particularly at the end of the fiscal year, when all remaining funds must be spent. Exchange pricing would reduce this source of uncertainty and might also encourage more accurate tracking of unserviceable carcasses to avoid penalties, although the ultimate financial effects would be the same as under separate prices and credits.

Exchange pricing would also reduce the number of transactions processed in both customer and provider financial systems, potentially decreasing DFAS and DISA bills.⁶ Financial inflows and outflows in

⁴In contrast, under the Army's current system, customers pay the full AMDF price for a purchase and there is a separate credit transaction for the matched return.

⁵"For the issue of a reparable item in which the requisitioner indicates a carcass will be returned, the customer will be charged the exchange price, i.e., the established repair cost plus the appropriate cost recovery elements. . . . The exchange price shall be established before the beginning of each fiscal year for each homogeneous group and provided to customers and shall remain constant throughout the execution fiscal year." *DoD Financial Management Regulation*, DoD 7000.14-R, Vol. 11B, p. 55-28.

⁶A 1993 Army study of exchange pricing predicted that it would increase the number of transactions, resulting in a \$30-\$40 million annual increase in DLA Distribution

the AWCF would be smaller, allowing the Army to maintain a lower cash balance.

Since exchange prices are based on the difference between prices and credits, they can incorporate the separate recommendations for prices and credits discussed in this chapter. Thus, exchange prices can be used to achieve the same benefits as separate price and credit policies designed to motivate OMA customers to use local repair, lateral redistribution, and local purchase only when it is cost-effective from an Army perspective. They have the additional benefit of reducing financial uncertainty and the number of financial transactions. However, some additional analysis would be needed to determine the impact of exchange pricing on AWCF cash flows and the automated system changes needed to implement exchange pricing.

CREDITS

Credits can be thought of as reflecting either the value of a serviceable or unserviceable asset to the Army or the cost of returning it to a serviceable condition and making it available to another customer. In the general case, when assets are not surplus to national need, the value to the supply system of a serviceable return is roughly equivalent to its replacement cost, so the characteristics of an optimal credit policy are relatively straightforward. But when assets are surplus to national need, the value to the supply system of a serviceable return is more ambiguous, and the Army does not want to give customers incentives to repair assets that should be thrown away. Therefore, we consider these two cases separately.

Assets Not Surplus to National Need

Assuming that prices are based on an adjusted acquisition cost and a surcharge that reflects the variable costs of managing, storing, distributing, and transporting the item (as described above), then the

Depot charges. Although we have not been able to review this study, this prediction was apparently based on the assumption that carcass returns could not be tracked unless DLRs were issued one at a time and that this would cause the increase in DIA charges. However, a carcass accounting system would not require serial number tracking or one-to-one matching of requisitions with returns, but simply a matching of returns against the oldest due-in.

credit for an Army-managed serviceable return that is not in surplus should be set at the adjusted acquisition cost. When a serviceable asset is returned, the AWCF avoids the cost of procuring a replacement or repairing an unserviceable asset, and the difference between the full price of the item and the serviceable credit recovers the AWCF's cost of transporting and restocking the asset. For some low-value items, the cost of transporting and restocking assets may exceed their value. The Army may therefore want to set a dollar-value threshold (e.g., \$50) below which it will not issue credit. Customers would then determine whether they preferred to dispose of these items or retain them for future use if they were not needed immediately.

For non-Army-managed serviceable returns, giving a similar type of credit (adjusted acquisition cost minus a surcharge for handling costs) would bring the assets into the AWCF and allow them to be redistributed among a wider range of customers than if customers retained the assets. However, the AWCF would also bear the risk that the assets could not be resold. Responsibility for these items should remain with the original source of supply, such as DLA or GSA. Thus, the Army should encourage DLA and GSA to improve their own credit policies for serviceable returns above a dollar-value threshold.

For Army-managed unserviceable returns (or non-Army-managed unserviceable returns with AWCF-funded GS repair programs), credit should be based on adjusted acquisition cost minus item-by-item repair cost. (An equivalent exchange price could be set at the item-by-item repair cost plus the surcharge to cover handling costs.) As discussed in Chapter Three, some changes would need to be made to depot repair pricing and wholesale logistics information systems to ensure that item-by-item repair costs were accurately allocated and recorded. Some costs that are currently allocated on the basis of labor hours, such as repair parts and supplies, storage, and transportation costs, should be allocated on an item-by-item basis. In particular, there is not necessarily a good correlation between the amount of time spent on a repair and the number and value of repair parts used. Actual hours spent and parts used in repairs should be used to update repair costs rather than relying on engineering standards. Fixed costs should be recovered through direct appropriations or through lump-sum payments from customers. The Army must then ensure that correctly allocated repair costs are recorded in

the wholesale logistics information systems so that estimated average repair costs are not used to calculate credit rates.

The Army may also want to consider some additional refinements of credit rates for selected items. Item-by-item repair costs are themselves an average of the costs of repairing unserviceable assets in varying conditions or with varying faults. Giving the same credit for the same item regardless of its condition may encourage customers to send back assets only in the worst condition, or with broken sub-components consolidated on a single carcass. For these items, the Army may want to vary credit rates based on the condition of the asset or the type of repair needed. However, since it is administratively more difficult to assign different credit rates for the same item, this type of policy is probably best reserved for high-value items when customers can influence the condition of the assets returned.

More accurate allocation of the costs of repairing, restocking, and transporting returns will reduce the financial incentives of OMA customers to create alternative redistribution systems for serviceable items and alternative repair programs for unserviceable items. Better cost allocation also helps ensure that the AWCF's revenues match the costs of repairing and restocking returned items.

Assets Surplus to National Need

Inventory management issues are somewhat different depending upon whether the surplus assets⁷ are serviceable or unserviceable. First, we consider the case where serviceable assets are in surplus.

When serviceable assets are in surplus. In this case, the Army can delay both procurement and repair until the surplus of serviceable assets has been depleted (taking repair or procurement lead times into account). It is important to avoid giving OMA customers incentives to repair unserviceable assets locally, since in most cases this will be a waste of resources from the Army's perspective. (It may still

⁷As mentioned above, national need is sometimes defined relative to the MRL, which is approximately seven years of supply at current demand rates, or the AAO, which is approximately two years of supply. Under SSF, national need should be redefined to reflect all Army inventories and demands.

be cost-effective to perform some minor repairs locally if they cost less than shipping a replacement to the customer.)

For some items, it may be necessary to reduce the net price of a purchase and an unserviceable return below depot repair costs to avoid inefficient use of local repair. This can be accomplished either by lowering the price (i.e., using the RPI) or by increasing the credit for an unserviceable.⁸ Although the effects on local repair incentives would be equivalent, these policies might have differing marginal effects on local inventories. A lower price would tend to encourage OMA customers to increase local inventories, whereas a higher credit would encourage them to return assets to the wholesale logistics system, where they could be set aside for future repair or disposal.

When unserviceable assets are in surplus. In this case, the Army can delay procurement, but repair must be made at either the wholesale or the retail level to meet demands. In most cases, the Army should continue to give credit for serviceable returns, since they can be redistributed through the supply system at little cost. To meet the remainder of demands, the carcasses in the best condition should be repaired, and those in the worst condition should be candidates for cannibalization and/or disposal. Generally, this may be best accomplished if the AWCF continues to give credit for unserviceable assets in surplus. If item-by-item credits or exchange prices are set as discussed above, so that the net price reflects depot repair, transportation, and restocking costs, then OMA customers will repair these assets only when it is cost-effective for the Army. When depot repair is more cost-effective, or the item is in worse than average condition, it could be sent for disposal or returned to the wholesale system for repair.

If the AWCF gave credit for unserviceable assets in surplus, it would bear the cost of writing off excess assets (either the worst-condition carcasses or some disassembled components). When no credit is given, OMA customers bear the costs of writing off assets but may not be disposing of the assets in worst condition. Giving credit for assets in surplus should reduce financial incentives for OMA cus-

⁸“National need” should be defined as a long-term condition, not one that can change frequently, so that changes in prices or credits for items that are surplus to national need do not create financial uncertainty for customers.

tomers to retrieve and repair assets sent to the Defense Reutilization Marketing Office (DRMO) for disposal, as long as customers are required to pay the same credit that was received for an item to remove it from DRMO.

Finally, there may be some items for which the Army will never need more assets and for which centralized management of unserviceable carcasses is not cost-effective. For these items, the best policy is to reduce the price for serviceable requisitions to the repair cost plus a surcharge for storage and transportation and give no credit for unserviceable returns. It is critical that these items be ones that will always be considered in surplus over the lifetime of the weapon systems they are used on, even if demand rates increase in response to lower prices. Otherwise, the Army may later find that it has to procure the item to meet demands, because it has been disposing of all unserviceable assets and none will be available for repair.

Many factors could influence which long-term policy (credit for serviceable and/or unserviceable returns or reduced price with no credit) makes economic sense for a specific item. The following characteristics would favor providing credits for unserviceable assets:

- High cost and complexity of repair and diagnosis;
- High “no evidence of failure” (NEOF) rates;
- High potential value of disassembled parts (item includes high-value components not in surplus);
- Low proportion of serviceable assets in surplus;
- Low number of total (serviceable plus unserviceable) assets in surplus relative to lifetime of weapon system;
- High uncertainty associated with demand, return, or washout rates.

Giving credit for assets in surplus would have an ambiguous effect on the cash balance of the AWCF. On one hand, the ability to delay procurement or repairs while excesses are drawn down should generate cash. On the other hand, giving credit for assets that might only be resold several years into the future could deplete cash. Depending upon the net effect, the Army might need either to withdraw cash

from the AWCF and return it to OMA budgets or to transfer cash into the AWCF and reduce OMA budgets to reflect additional credit received from the AWCF. In either case, the Army would need to carefully monitor changes in cash flows at a sufficient level of detail to identify and correct cash surpluses and shortages.⁹

APPLYING THE CRITERIA TO AN “OPTIMAL” POLICY

A price and credit policy based on the characteristics described above would satisfy the criteria introduced in Chapter Two, with the possible exception of AWCF cash flows for assets in surplus. (See Figure 4.1.) Customers should be able to maintain planned OPTEMPO with the same or lower budgets, if credits are increased for non-Army-managed consumables and assets in surplus. Prices and credits that are set to reflect the variable costs of transactions could resolve many of the customer incentive problems that the Army is currently experiencing with its price and credit policies for spare parts. When OMA customers have accurate information about the costs of the wholesale supply system, they will use local repair facilities, lateral redistribution, and local vendors only when it is cost-effective from an Army perspective. Eliminating the dependence of credits on installation NAP will reduce financial uncertainty and make it easier for commanders to monitor and spend their budgets to maintain OPTEMPO.

From an AWCF perspective, total costs can be recovered more dependably when fixed costs are funded by direct appropriations or lump-sum payments from customers and when the variable costs of supply and repair are funded by prices net of credits. For assets that are not in surplus, revenues would be better matched to costs, so that the AWCF could more easily be kept in balance. For assets in sur-

⁹An analysis of the effects of recommended price and credit policy changes on OMA and AWCF accounts is beyond the scope of this report. However, the impacts of some of the recommended policy changes on required OMA budgets and AWCF inventory replenishment costs were estimated in Brauner et al., *Evaluating Five Proposed Price and Credit Policies for the Army*. A full analysis would be difficult to conduct, since Army data do not allow us to estimate potential behavioral changes on an item-by-item basis, nor are detailed data available on the costs of non-AWCF transactions, such as local purchase and redistribution. Some concerns could be addressed by pilot projects that adjusted prices and credits for groups of items to assess the impacts on demands and returns.

RAND MR1150-4.1

Criteria for customers	Pre-SSF Policy	SSF Policy	"Future" Policy	"Optimal" Policy
Maintain OPTEMPO	+	+	--	+
Local inventories sized to meet demands	-	+/-	--	+
Appropriate use of local purchase, redistribution, and local vs. depot repair	-	+/-	--	+
Reduce financial uncertainty	-	+	+	+

Criteria for suppliers	Pre-SSF Policy	SSF Policy	"Future" Policy	"Optimal" Policy
Keep AWCF in balance	+	+	-	+/?
Reduce surplus inventories	-	-	-	+
Appropriate use of depot, contractor, and local repair	-	+/-	-	+

Figure 4.1—Application of Criteria to "Optimal" Policy

plus, the AWCF might either gain or lose cash. However, with careful monitoring, cash transfers between OMA and AWCF could be used to compensate for gains or losses in the AWCF.

More accurately determined depot repair prices will facilitate comparisons with installation Directorates of Logistics (DOLs) and contractors under National Maintenance Management. To reduce surplus inventories, the Army should determine its credit policies on an item-by-item basis, taking into account whether an item is genuinely surplus over the lifetime of the weapon system that uses it.

Price and credit policies should be considered from an Army-wide perspective, emphasizing real costs to the Army, such as procurement and repair costs, and using accounting transactions between AWCF and OMA to create appropriate financial incentives for OMA customers. As the Army designs its 21st century integrated logistics and financial management information systems, it should consider how to incorporate price and credit policies that reflect optimal characteristics from a global Army perspective and to monitor AWCF cash flows more accurately.

HISTORY OF THE REDUCED PRICE INITIATIVE (RPI)

In 1995, the Army reduced the price of a small number of items that had been designated as being in surplus. The prices of these items were set at LAC times the supply management surcharge, i.e., at 15–25 percent of the previous AMDF price.¹ The Army hoped that these dramatic price reductions would discourage local repair of the items, since the Army already had all the inventories it needed. The initial list contained fewer than 200 items, many of which were obsolete and, therefore, not being ordered by customers. In FY99, the RPI list grew substantially to 1,224 items. These items were described as “active and semi-active reparable items.”²

The policies governing the RPI were further revised in February 1999 (to take effect on 1 October 1999) to include both reparable and Army-managed consumable items. It is instructive to discuss these revisions in light of the criteria developed in this report. However, the revisions were never implemented, and there was no RPI in FY00 or under SSF.

PROPOSED FY00 RPI (UNIMPLEMENTED)

Reduced prices were set at 50 percent of the previous AMDF price. Credits for unserviceable items on the RPI list were reduced to zero,

¹The surcharge rate in 1995 was 23.8 percent.

²The description of the Reduced Price Initiative given in this appendix is based on LTG John G. Coburn, “Memorandum: Revision to Policy and Procedures Affecting the Reduced Price Initiative,” February 8, 1999.

with instructions to send them to DRMO for disposal. Serviceable items on the RPI list continued to receive credit based on pre-SSF (RSF to OMA) credit policies: 100 percent if the item was needed on the installation, 45–55 percent for depot-level reparable (DLRs) not needed locally, and 5 percent for field-level reparable (FLRs) and consumables not needed locally.

Under the proposed FY00 RPI policy, the criteria for RPI candidates were as follows:

1. The item must be Army-managed;
2. The item may be consumable or reparable;
3. The item must be active or semi-active (it may not be obsolete);
4. There must be enough inventory on hand for the item to remain on the RPI list for at least one year;
5. There must be assets above the Approved Acquisition Objective (AAO).

The proposed FY00 RPI policies incorporated several improvements. The list included items that customers were using. Higher prices allowed the AWCF to recover some of its investment in the assets and to pay for repairs if surplus serviceable items were depleted at some time in the future. Some additional modifications could have resulted in further improvements. Setting reduced prices at 50 percent of the previous level could result in financial incentives for continued local repair if repair costs are less than 50 percent of the previous price. If reduced prices were set slightly lower than repair costs on an item-by-item basis, customers would no longer have a financial incentive to repair RPI items. In addition, giving no credit for unserviceable items in surplus may not be the optimal policy from an Army-wide perspective, as discussed in Chapter Four above. However, under the SSF price and credit policy, the Army has decided to end the RPI, and the proposed FY00 policy was never implemented.

BIBLIOGRAPHY

Baldwin, Laura H., and Glenn A. Gotz, *Transfer Pricing for Air Force Depot-Level Repairables*, Santa Monica, CA: RAND, MR-808, 1998.

Brauner, Marygail, John Bondanella, Ellen Pint, Dan Relles, and Paul Steinberg, *Dollars and Sense: A Process Improvement Approach to Logistics Financial Management*, Santa Monica, CA: RAND, MR-1131-A, 2000.

Brauner, Marygail, Ellen Pint, Daniel Relles, John Bondanella, Paul Steinberg, and Rick Eden, *Evaluating Five Proposed Price and Credit Policies for the Army*, Santa Monica, CA: RAND, DB-291-A, 2000.

Brauner, Marygail, John Bondanella, Joe Bolten, Lionel Galway, Ellen Pint, Elizabeth Ondaatje, and Jerry Sollinger, *ISM-X Evaluation and Policy Implications*, Santa Monica, CA: RAND, MR-829-A, 1997.

Coburn, LTG John G., "Memorandum: Revision to Policy and Procedures Affecting the Reduced Price Initiative," February 8, 1999.

Dumond, John, Rick Eden, and John Folkeson, *Velocity Management: An Approach for Improving the Responsiveness and Efficiency of Army Logistics Processes*, Santa Monica, CA: RAND, DB-126-1-A, 1995.

Dumond, John, Marygail K. Brauner, Rick Eden, John Folkeson, Kenneth Girardini, Donna Keyser, Eric Peltz, Ellen M. Pint, and Mark Y.D. Wang, *Velocity Management: The Business Paradigm*

- That Has Transformed U.S. Army Logistics*, Santa Monica, CA: RAND, MR-1108-A, 2001.
- Eccles, Robert G., "Transfer Pricing as a Problem of Agency," in J. Pratt and R. Zeckhauser (eds.), *Principals and Agents: The Structure of Business*, Boston: Harvard Business School Press, 1991, pp. 151–186.
- Edwards, Thomas J., and Rick Eden, *Velocity Management and the Revolution in Military Logistics*, Santa Monica, CA: RAND, RP-752, 1999.
- Fricker, Ronald D., Jr., and Marc Robbins, *Retooling for the Logistics Revolution: Designing Marine Corps Inventories to Support the Warfighter*, Santa Monica, CA: RAND, MR-1095-USMC, 1999.
- Galway, Lionel A., and Christopher H. Hanks, *Data Quality Problems in Army Logistics: Classification, Examples, and Solutions*, Santa Monica, CA: RAND, MR-721-A, 1996.
- Girardini, Kenneth J., William Lewis, Rick Eden, and Earl Gardner, *Establishing a Baseline and Reporting Performance for the Order and Ship Processes*, Santa Monica, CA: RAND, DB-173-A, 1996.
- Halal, William E., "From Hierarchy to Enterprise: Internal Markets Are the New Foundation of Management," *Academy of Management Executive*, Vol. 8, No. 4, 1994, pp. 69–83.
- Harris, M., C. H. Kriebel, and A. Raviv, "Asymmetric Information, Incentives, and Intrafirm Resource Allocation," *Management Science*, Vol. 28, No. 6, June 1982, pp. 604–620.
- Hirshleifer, Jack, "On the Economics of Transfer Pricing," *Journal of Business*, Vol. 29, 1956, pp. 172–184.
- Kovac, Edward J., and Henry P. Troy, "Getting Transfer Prices Right: What Bellcore Did," *Harvard Business Review*, September–October 1989, pp. 148–154.
- Moore, Nancy Y., J. M. Halliday, K. M. Beam, D. W. McIver, M. W. Lewis, F. W. Finnegan, and T. Masselink, *Materiel Distribution: Improving Support to Army Operations in Peace and War*, Santa Monica, CA: RAND, MR-642-A, 1997.

Office of the Under Secretary of Defense (Comptroller), *A Plan to Improve the Management and Performance of the Department of Defense Working Capital Funds*, September 1997.

Robbins, Marc L., Patricia Boren, Rick Eden, and Daniel Relles, *Measurement of USMC Logistics Processes: Creating a Baseline to Support Precision Logistics Processes*, Santa Monica, CA: RAND, DB-235-USMC, 1998.

Rogerson, William P., *On the Use of Transfer Pricing Within DoD*, McLean, VA: Logistics Management Institute, PA303RD1, March 1995.

Single Stock Fund Program Management Office, *Single Stock Fund Test and Evaluation Plan for Demonstration of Milestones 1 & 2*, March 16, 2000, downloaded from <http://www.army.mil/ssf/tep/temp/temp.html>, May 20, 2000.

Trunkey, R. Derek, and Jino Choi, *The Defense Business Operations Fund (DBOF): Problems and Possible Solutions*, Alexandria, VA: Center for Naval Analyses, CRM 95-196, March 1996.

Tsai, Michael J., and Peter Evanovich, *Evaluating the Use of Contractors for Installation Support Using Service Based Cost Data*, Alexandria, VA: Institute for Defense Analyses, September 1999.

U.S. Army, Army Working Capital Fund, *FY 2000/2001 Biennial Budget Estimates*, undated.

U.S. Army Cost and Economic Analysis Center, "Resourcing Army Training," briefing to the Credit and Pricing Integrated Product Team, March 24, 1998.

Wallace, John M., Dale A. Kem, and Caroline Nelson, *Another Look at Transfer Prices for Depot-Level Repairables Marginal Costs: A Revenue Perspective*, McLean, VA: Logistics Management Institute, PA602T1, January 1999.

Wang, Mark Y. D., *Accelerated Logistics: Streamlining the Army's Supply Chain*, Santa Monica, CA: RAND, MR-1140-A, 2000.

How do prices and credits for spare parts affect the behavior of logistics customers and suppliers and the performance of the Army logistics system as a whole?

This report develops a set of criteria to evaluate Army price and credit policies from an Army-wide perspective. The criteria are based on the types of decisions that must be made by logistics customers and suppliers, and the effects of these decisions on inventories, cash flows, and the ability of logistics customers in operating units to perform their missions within their budgets. The authors apply these criteria to current and proposed price and credit policies and use them to define the characteristics of an optimal policy.

ISBN 0-8330-2952-5



9 780833 029522

MR-1150-A