

REPORT DOCUMENTATION PAGE

Form Approved
OMB No. 0704-0188

Public reporting burden for this collection of information is estimated to average 1 hour per response, including the time for reviewing instructions, searching data sources, gathering and maintaining the data needed, and completing and reviewing the collection of information. Send comments regarding this burden estimate or any other aspect of this collection of information, including suggestions for reducing this burden to Washington Headquarters Service, Directorate for Information Operations and Reports, 1215 Jefferson Davis Highway, Suite 1204, Arlington, VA 22202-4302, and to the Office of Management and Budget, Paperwork Reduction Project (0704-0188) Washington, DC 20503.

PLEASE DO NOT RETURN YOUR FORM TO THE ABOVE ADDRESS.

1. REPORT DATE (DD-MM-YYYY) 07 Apr 2002		2. REPORT TYPE Final		3. DATES COVERED (From - To) 01 Oct 1996 - 30 Sep 2001	
4. TITLE AND SUBTITLE Stack/Heat-Exchanger Research for Thermoacoustic Heat Engines				5a. CONTRACT NUMBER	
				5b. GRANT NUMBER N00014-97-1-0008	
				5c. PROGRAM ELEMENT NUMBER 61153N	
6. AUTHOR(S) Maynard, Julian D.				5d. PROJECT NUMBER	
				5e. TASK NUMBER	
				5f. WORK UNIT NUMBER	
7. PERFORMING ORGANIZATION NAME(S) AND ADDRESS(ES) The Pennsylvania State University 104 Davey Lab University Park PA 16802				8. PERFORMING ORGANIZATION REPORT NUMBER	
9. SPONSORING/MONITORING AGENCY NAME(S) AND ADDRESS(ES)				10. SPONSOR/MONITOR'S ACRONYM(S)	
				11. SPONSORING/MONITORING AGENCY REPORT NUMBER	
12. DISTRIBUTION AVAILABILITY STATEMENT Approved for public release: Distribution unlimited					
13. SUPPLEMENTARY NOTES					
20020425 009					
14. ABSTRACT The goal of this project was to develop novel configurations of heat pumping elements and heat exchangers for thermoacoustic heat engines. The approach involved the use anisotropic systems employing innovative technology. Th approach allowed a heat exchange fluid to flow directly across the heat pumping element of the thermoacoustic heat engine (the "stack"), eliminating the necessity of separate heat exchangers and improving efficiency. The research has led to a radically new design, which is robust (using stainless steel and durable materials), relatively easy to fabricate, an employs a filament array or "pin" stack. One patent has been awarded, and a second is in process. Several companies which can fabricate crucial components for future refrigerators were identified in the course of the research. The research formed the basis for a Ph.D. thesis.					
15. SUBJECT TERMS Acoustics, Thermodynamics, Heat Engine, Refrigerator					
16. SECURITY CLASSIFICATION OF:			17. LIMITATION OF ABSTRACT	18. NUMBER OF PAGES	19a. NAME OF RESPONSIBLE PERSON
a. REPORT	b. ABSTRACT	c. THIS PAGE			19b. TELEPHONE NUMBER (Include area code)
U	U	U		19	

Stack/Heat-exchanger Research for Thermoacoustic Heat Engines

Final Report October 1, 1996 - September 30, 2001

Julian D. Maynard
The Pennsylvania State University
Department of Physics, 104 Davey Lab
University Park, PA 16802
Voice: 814-865-6353, FAX: 814-865-3604
E-Mail: maynard@phys.psu.edu

N00014-97-1-0008
Dr. Logan E. Hargrove

Introduction

This final report presents the accomplishments for ONR grant N00014-97-1-0008, "Stack/heat-exchanger research for thermoacoustic heat engines". The goal of the research was to improve the efficiency of a new type of refrigerator (the thermoacoustic refrigerator, or TAR) by developing a device which more effectively integrates the heat pumping element of the refrigerator with its heat exchangers. The device, referred to as an anisotropic stack/heat-exchanger (ASHE) unit, was designed, fabricated, instrumented, and fully tested in an existing TAR which had been characterized with a conventional stack and heat-exchangers in previous studies. The current research was quite successful, with the new device having a robust stainless steel construction and showing a factor of two improvement in efficiency over the existing TAR technology. Some highlights of the research are as follows:

- A theoretical model for the performance of the ASHE was developed.
- A high amplitude (0.8 atm) acoustic test facility, using a modified model aircraft engine driven with a regulated high-speed wood-working router motor, was constructed.
- Companies which could provide some specialized components for TAR's were identified. This is very important for the continued development of the TAR.
- For the 1997 Penn State University Graduate Research Exhibition, David Zhang demonstrated a small TAR using a hi-fi speaker, a plexiglas resonator, and a stack instrumented with thermocouples. Attendees could press a button and watch the temperature drop. Zhang's exhibit was featured in two local newspaper articles, as well as in an article in *Technical Insights* magazine.
- A patent, number 5,717,266, for a "High power oscillatory drive" appropriate for an annular TAR, was awarded to the Principal Investigator on February 10, 1998.
- A second patent, "Stack/Heat-exchanger Unit for Thermoacoustic Heat Engines", is in process with the Penn State Intellectual Property Office.

- The graduate student involved in the research from the beginning, David Zhang, successfully defended his Ph.D. thesis, *Design and Study of an Anisotropic Stack/Heat-exchanger for a Thermoacoustic Refrigerator*, in October, 2001.

In the sections which follow, a technical review of this research program is provided.

Motivation

A major contributor to the depletion of the earth's ozone layer is the reaction of the ozone with chloro-flouro-carbons (CFC's) which are released into the earth's atmosphere from refrigerators which leak CFC's. [Note: by a general definition, refrigerators include air conditioners, etc.] In order to satisfy current and anticipated regulations governing the use of CFC's, it will be necessary to develop new types of refrigerators which do not use CFC's. A promising technology involves the thermoacoustic effect, in which the oscillatory motion of a gas in an acoustic field is coupled to a temperature gradient at a solid surface parallel to the motion. Reviews of this effect and its application in refrigerators and other heat engines (some nearing commercialization), are available in the literature. [1,2]

In a conventional CFC type refrigerator, the working fluid is compressed by mechanical means (involving sliding seals), allowed to expand, causing heat flow from its environment, and then re-compressed to form a cycle. In a sound wave, the acoustic medium is also cyclically compressed and expanded, but in a free fluid the process involves no heat flow. However, if the acoustic fluid oscillates parallel to a solid surface, then heat may be exchanged with the solid surface resulting in a net pumping of heat along the surface.

In order to increase the heat carrying capacity of the thermoacoustic heat engine, a large number of solid surfaces are used in a parallel configuration, as in a stack of plates, a spiraling sheet, an array of pores, or an array of filaments or "pins"; this part of the thermoacoustic heat engine is referred to as the "stack". An exploded view of a thermoacoustic refrigerator (TAR) is shown in Fig. 1. At the left in Fig. 1 is the acoustic driver, represented as an oscillating piston. Next is an open section of a longitudinal standing wave acoustic resonator, followed by the stack. At each end of the stack are heat exchangers, represented by fluid-carrying pipes in Fig. 1, which would connect the refrigerator to an ambient temperature reservoir and to the load to be cooled. Finally, at the right end in Fig. 1 is the termination for the acoustic resonator.

The sealed acoustic resonator is filled with a non-CFC gas, such as a helium-argon mixture. It should be noted that the spacing of the surfaces in the stack (or the inside diameter of pores, or the spacing between pins in a pin-stack array) is on the order of the thermal penetration depth for the gas, typically a few hundred microns. It should also be noted that the stack should have low thermal conductivity in the direction of the acoustic oscillation in the resonator, so that the stack material does not "short-out" the thermal gradient which it is trying to produce.

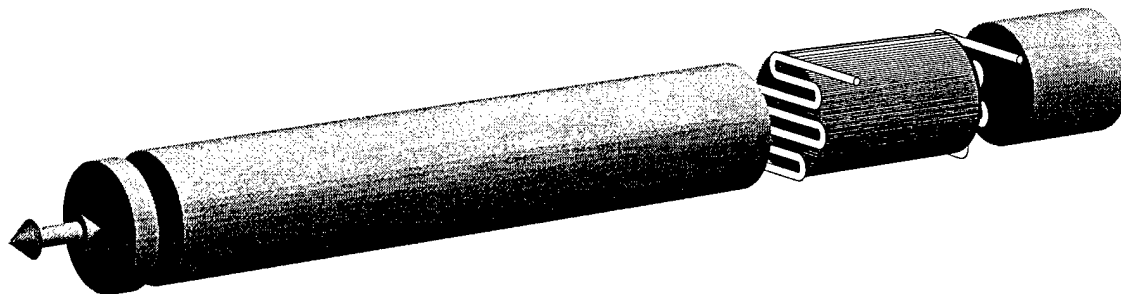

Figure 1. Schematic diagram of a thermoacoustic refrigerator. From left to right: an acoustic driver (oscillating piston), an acoustic plane wave resonator, a stack with heat exchangers at each end, and the termination of the acoustic resonator.

Key elements in a high power thermoacoustic refrigerator are the heat exchangers at the ends of the stack; a schematic of one conventional type of TAR heat exchanger is illustrated in Fig. 2. Fig. 2a shows the stack illustrated on the left and meandering pipes (side view) carrying a heat exchanger fluid illustrated to the right. Fig. 2b is an end view, looking down the acoustic resonator.

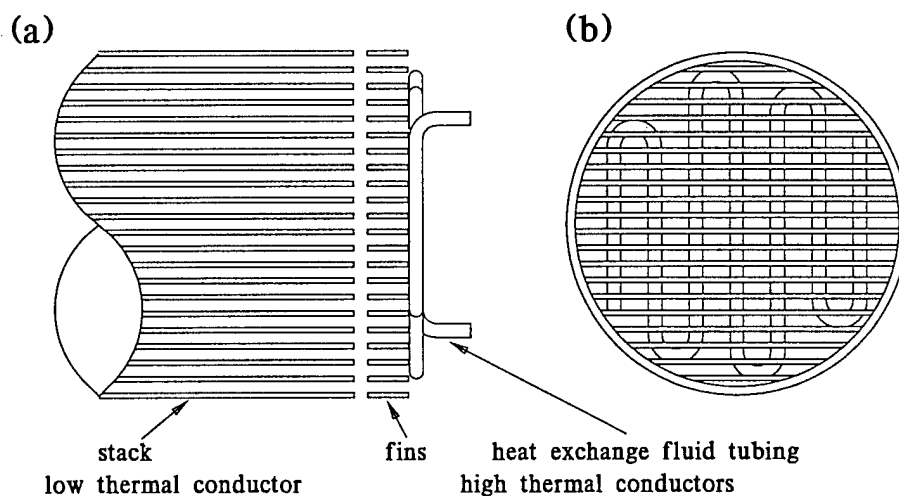

Figure 2. Schematic of a conventional thermoacoustic refrigerator heat exchanger. In Fig. 2a the stack is to the left, and meandering pipes carrying a heat exchanger fluid are to the right; fins are used to match the length scale of the stack (tenths of a millimeter) to that of the pipes (several millimeters). Fig. 2b is an end view.

Difficulties arise from the disparity in the length scales between the stack (with a scale of several hundred microns) and the heat exchanger pipes (with a scale of several millimeters). Often fins (with high thermal conductivity) are employed at an intermediate length scale between the stack and the heat exchanger pipes, thereby comprising a “tube-and-fin” heat exchanger. One difficulty is that the separately constructed heat-exchanger usually does not have a fin configuration which actually matches the configuration of the stack. A second difficulty is that an additional path of heat conduction, along the thin fins and through

junctions with the pipes, has been added. Yet another difficulty is that for an isothermal heat-exchanger, the length of the exchanger (in the direction of the gas particle velocity) is usually on the order of the gas particle peak-to-peak displacement (as large as several millimeters). Such an isothermal exchanger poses a fundamental limitation, because the isothermal surface (unlike the surface with a temperature gradient in the stack) is a source of acoustic power loss. Thus it may be concluded that a TAR could be improved if the heat-exchanger were incorporated into the stack with a matching length scale, with provision for heat exchange graded in temperature.

The TAR device developed in this research program involves a heat exchanger combined with a stack to form a unit. The heat-exchanger uses a fluid flowing in pipes, but without the necessity of fins. It can not only handle higher heat loads, but can also permit heat exchanges graded in temperature. That is, the temperature of the heat-exchanger fluid entering and exiting the external heat-exchanger could be made to match the temperature at the point of entry or exit of the exchanger in the stack. The heat exchanger has the basic geometry of a "tube-and-shell" heat exchanger, but with the innovation of having a very small size scale which matches the fundamental length scale of the stack; the heat exchanger consists of an array of very small diameter, thin-walled stainless steel capillary tubes.

The device also employs a pin stack, whose advantages are described elsewhere. [3,4] However, the pin stack actually fabricated for the device in this research program contains an important innovation, which will be described later. Like the heat exchangers, the pin stack is made of stainless steel.

As for an ideal TAR stack and heat exchanger, the device developed in this research program has low thermal conductivity along the stack, but at the ends the heat exchangers, with flowing heat exchange fluid, have high thermal conductivity across the stack. Thus the device is highly anisotropic in thermal conductivity, and the device is referred to as an anisotropic stack/heat-exchanger (ASHE) unit. By employing stainless steel, the ASHE unit is mechanically, thermally, and chemically robust.

Model design for the anisotropic stack/heat-exchanger unit

The model design for the anisotropic stack/heat-exchanger is most easily described by indicating, in a simplified manner, how the ASHE unit is constructed; this is illustrated in Fig. 3. This ASHE unit has a square cross section, and lengths are not drawn to scale. As already mentioned, the stack is a "pin-stack"; it consists of a stack of special plates, one of which is shown schematically in Figs. 3a and 3b. Each plate is fabricated from a thin (0.05 mm) stainless steel sheet; elongated openings (of width 0.25 mm) are chemically etched in the plate resulting in an array of square cross-section (0.05 x 0.05 mm) pins. Wide sections across the plate provide additional support for the pin array. As shown to the right in Fig. 3a and in Fig. 3b, ridges of height 0.30 mm are pressed into the plate along its length. These ridges provide longitudinal rigidity as well as spacing between the plates when stacked; the ridges are asymmetric across the plate, so that when the plates are stacked with alternating orientations, the ridges alternate in position, as may be seen in Fig. 3c and Fig. 4.

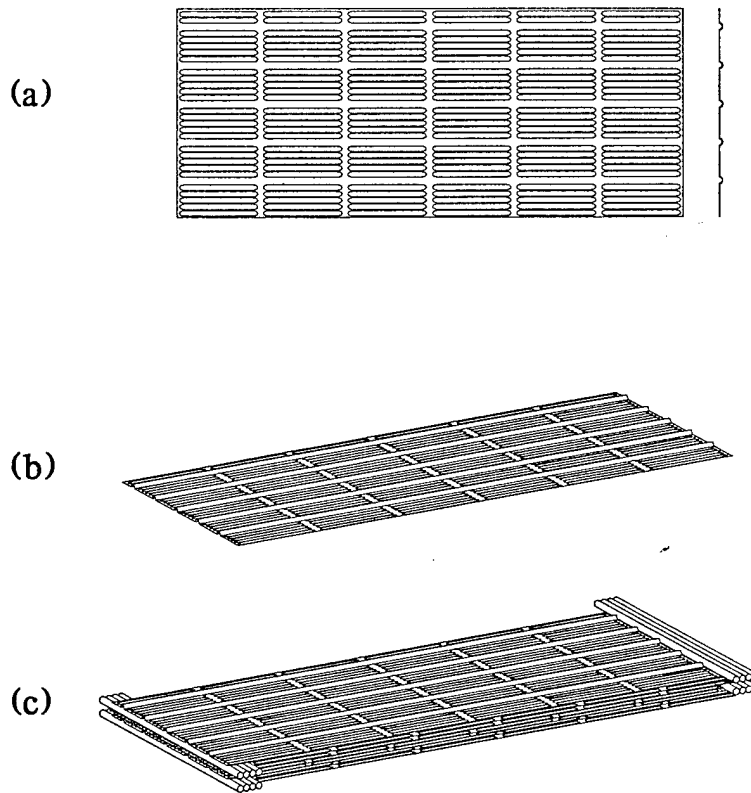

Figure 3. Illustration of the construction of the anisotropic stack/heat-exchanger (ASHE) unit. a) Thin plates etched to form an array of pins, with ridges for rigidity and spacing b) isometric view of a pin stack plate c) illustration of the assembly procedure.

Assembly of the stack/heat-exchanger unit is illustrated in Fig. 3c, which shows the pin-stack plates with thin-walled tubes (of 0.60 mm overall diameter, 0.025 mm wall thickness) for carrying the heat-exchanger fluid running laterally across the plates. The lateral heat-exchanger tubes and the longitudinal pins comprise the orthogonal basis of the anisotropic stack/heat-exchanger. The positioning of the tubes and plates may be described as follows. At the lowest level, a line of tubes (four in the illustration in Fig. 3c) is positioned at the end of two stacked plates. At the next level, two more plates are stacked, with a line of tubes at the end opposite that of the first layer, and staggered so that the tubes lie on top of the plates below. This process is repeated until an ASHE unit is formed as in Fig. 4; the right part of Fig. 4 is an end view photograph of an actual ASHE unit. It should be noted in this photograph that the pin-stack plates do not have to be perfectly flat and parallel; the pins may be somewhat jumbled, provided that they mostly have the nominal spacing determined by the thermal penetration depth in the acoustic gas.

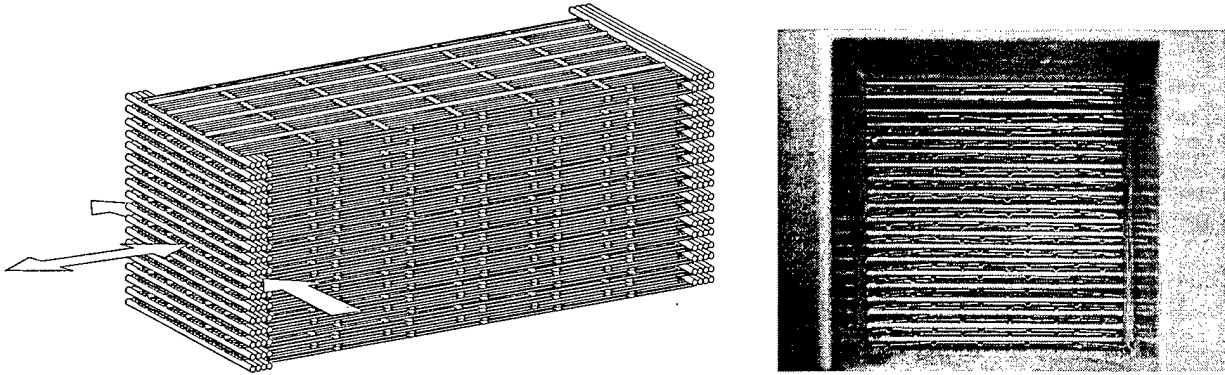

Figure 4. Assembled anisotropic stack/heat-exchanger unit, in schematic form (with acoustic gas motion and heat exchanger fluid motion indicated), and an end view photograph of an actual ASHE unit.

In the ASHE unit illustrated in Fig. 4, the acoustic gas oscillates through the openings between the heat-exchanger tubes and longitudinally along the pins in the stack plates; the heat-exchanger fluid flows at right angles through the tubes. The heat to or from the acoustic gas near the ends of the stack conducts through the thin walls of the tubes, and is transported by the heat-exchange fluid.

Actual assembly of an ASHE unit may be facilitated with a frame as illustrated in Fig. 5. The assembly process involves placing a layer of tubes across the frame, passing through the holes at one end, along with two pin-stack plates at the same level, which extend to the opposite end of the frame. Next, another layer of tubes is placed through holes at the opposite end, positioned just above the first layer of plates, and another layer of plates is added. At each level, the ends of the tubes may be sealed to the holes in the frame, isolating the inside of the heat-exchanger tubes from the stack region inside the frame. After the frame is filled, the top may be sealed with a plate, and heat-exchanger fluid manifolds may be sealed around the ends of the frame. The frame illustrated in Fig. 5 permits using a square cross-section ASHE unit inside a cylindrical acoustic resonator. The frame must be made of a material which has a low thermal conductivity, such as plastic.

An alternative method for fabricating an ASHE unit is shown in the photograph in Fig. 6. In this case the capillary array heat exchanger is assembled separately in a metal section, so that the capillary tubes and other parts may be soldered in place. This figure shows an open manifold chamber which permits careful soldering of the capillary tubes, and also allows for repair of individual tubes. Some open ends of the capillary tubes, in a 6 by 20 array, are visible in Fig. 6. The sides of the device in Fig. 6 which run parallel to the capillary tubes are made of stainless steel (in order to match the thermal expansion of the stainless steel capillaries) and the other sides are made of copper; this is done to facilitate the process of soldering the capillary tubes in place.

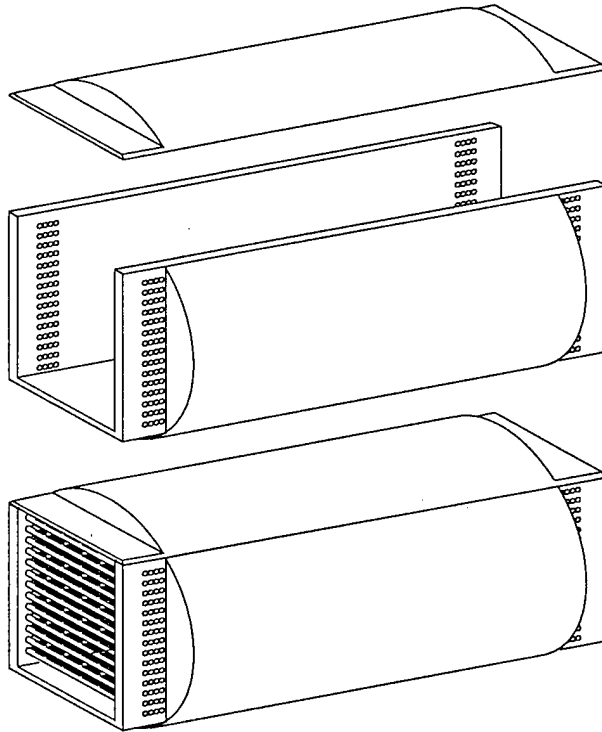

Figure 5. A frame for facilitating the assembly of an anisotropic stack/heat-exchanger unit.

The manifold chambers (one on each side of the capillary tube array) are sealed with curved outer walls (not shown); heat exchanger fluid passes into one manifold chamber and out the other through flattened ducts, one of which is visible in Fig. 6. It is possible to fabricate more sophisticated devices which permit multiple manifolds for graded heat exchangers. Pin-stack plates are inserted through the openings between the layers of capillary tubes to form the complete ASHE unit.

Some theoretical considerations

In the illustrated anisotropic stack/heat-exchanger, the acoustic gas oscillates through the openings between the heat-exchanger tubes (as may be seen in Fig. 4) and longitudinally along the pins in the stack plates; the heat-exchanger fluid flows at right angles through the tubes. The heat to or from the acoustic gas near the ends of the stack conducts through the thin walls of the tubes, and is transported by the heat-exchange fluid. A question which arises is: Will having to push the heat-exchange fluid through narrow tubes be detrimental? To address this question, some heat-exchanger fundamentals should be reviewed. In this treatment, we simplify the situation by replacing a single row of capillaries with one wide duct with a (low) height equal to the diameter of one capillary, essentially a parallel plate geometry.

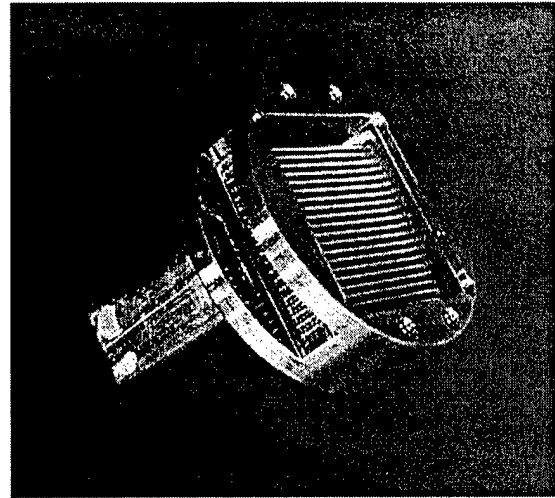

Figure 6. The capillary array heat exchanger assembled in a separate metal section, as an alternate method of fabricating an ASHE unit.

Some basic concepts for heat-exchangers are illustrated in Fig. 7. We consider a geometry consisting of two parallel isothermal walls at temperature T_w with a heat-exchange fluid flowing between them, entering at a temperature $T_0 < T_w$. Heat leaving the plates is carried away by the moving heat-exchange fluid. Two basic modes for heat-exchange fluid flow, laminar and turbulent, are illustrated in Figs. 7a and 7b. The flow profile for laminar flow is shown by the parabola-shaped curves in Fig. 7a; the flow is parallel to the walls, is maximum in the center, and drops to zero at the walls. At the entrance (the left end in Fig. 7a) the temperature rises abruptly at the walls. For a wall spacing typical of refrigeration tubing (several mm), the consequence of these profiles is that the heat diffuses only a small distance from the walls where the flow is small, so that little heat is carried away. If the fluid is pushed fast enough between the walls, the flow becomes turbulent, as shown in Fig. 7b. In this case, perpendicular flow of the fluid near the walls convects the heat into the center of the channel where it is more effectively carried away by the mean flow of the fluid.

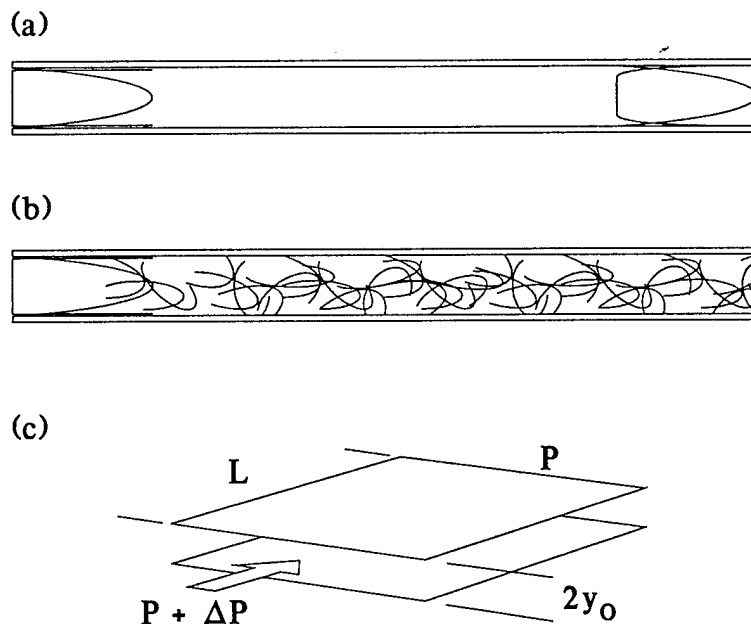

Figure 7. Illustration of some situations relevant to heat exchangers with fluid flow. a) laminar flow between walls b) turbulent flow between walls c) some parameters relevant to the theory.

For typical millimeter sized refrigeration tubing, turbulent flow is better for heat exchange. We now use a theoretical calculation to see if making the walls close together (as in narrow slits or small diameter capillaries) might make the laminar flow situation more effective.

The theory involves the equation of continuity, the Navier-Stokes equation, and conservation of energy, including heat conduction:

$$\frac{\partial \rho}{\partial t} + \vec{\nabla} \cdot (\rho \vec{v}) = 0 \quad (1)$$

$$\frac{\partial \vec{v}}{\partial t} + \vec{v} \cdot \vec{\nabla} \vec{v} = -\vec{\nabla} P + \eta \nabla^2 \vec{v} + \left(\xi + \frac{1}{3} \eta \right) \vec{\nabla} (\vec{\nabla} \cdot \vec{v}) \quad (2)$$

$$\frac{\partial S}{\partial t} + \vec{v} \cdot \vec{\nabla} S = \vec{\nabla} \cdot (\kappa \vec{\nabla} T) \quad (3)$$

where, for the heat-exchange fluid, ρ is the mass density, \vec{v} is the flow velocity field, P is the pressure, η and ξ are the shear and bulk viscosities, κ is the thermal conductivity, T is temperature, and S is the entropy.

For steady, incompressible flow between parallel walls, with spacing $2y_0$ as illustrated in Fig. 4c, the first two equations yield:

$$P(x, y) = -\frac{\Delta P}{L} x \quad (4)$$

$$\vec{v}(x, y) = \frac{\Delta P y_0^2}{2\eta L} \left(1 - \frac{y^2}{y_0^2} \right) \quad (5)$$

where L is the length from the left to the right end of the heat-exchanger and ΔP is the pressure drop across L . The net flow of heat exchange fluid is proportional to y_0^2 , so that it would seem that narrow slits would be a disadvantage. Indeed, this impedance limits the flow to laminar for reasonable values of ΔP . However, the calculation must be continued to find the net heat transport, given by the thermal conductance:

$$\frac{\dot{Q}}{\Delta T} = \left(\frac{\Delta P \rho C_p}{8\eta L} \right) \sum_{n=1}^{\infty} A_n y_0^2 [1 - e^{-(\zeta_n/y_0)^4}] \quad (6)$$

where

$$\zeta_n = \left[\frac{2\gamma_n \eta L^2 \kappa}{\Delta P \rho C_p} \right]^{1/4} \quad (7)$$

$\Delta T = T_w - T_0$, and γ_n is a numerical eigenvalue.

For large y_0 (3 mm), $\dot{Q}/\Delta T$ decreases with y_0 , reiterating that laminar flow is undesirable. However, for small y_0 it increases. For $L \sim 5 - 10$ cm, the maximum thermal conductance occurs for a wall spacing of a hundred microns, the same as the typical spacing for a stack. This favorable result may be seen as arising from the similarity between the formula for the thermal penetration depth

$$\delta = \sqrt{\frac{\kappa}{\rho C_p f}} \quad (8)$$

and that for the optimum plate spacing

$$2y_0 = \sqrt{\frac{\kappa}{\rho C_p (v/L)}} \quad (9)$$

where f is the frequency of the acoustic resonance and v is the average heat-exchanger fluid flow velocity. For a typical TAR, f and v/L are comparable.

Another quantity to consider is the energy lost through viscosity in pushing the heat-exchange fluid through the narrow slits. This is calculated with the product of ΔP and v . If one uses typical values for the parameters for a stack, one finds that the performance of a stack/heat-exchanger unit as illustrated in Fig. 4, with 0.60 mm diameter, 0.025 wall tubes, is comparable to that of a conventional TAR heat exchanger formed with 3 mm ID copper refrigerator tubing, but with the advantages that there is much better thermal contact with the thermoacoustic gas in the stack, and by using several sections of tubes, a graded heat exchanger may be formed. Thus the ASHE unit is predicted theoretically to have superior performance as a heat exchanger.

Heat exchanger performance test

While theory predicts that an array of capillaries should perform well as a heat exchanger, this conclusion must be tested experimentally. For this purpose, a capillary array heat exchanger separated from a stack, such as the one shown in Fig. 6, was used in a performance test. The heat exchanger manifolds, shown open in Fig. 6, were closed so that heat exchanger fluid (water) could be pumped through the capillary array tubes. A differential pressure transducer was used to measure the pressure drop Δp across the heat exchanger as a function of the volumetric flow rate, U , for the water passing through the capillary tubes. The volume outside the capillary tubes (i.e. the volume which would be occupied by the acoustic gas) was packed with a high thermal conductivity grease, with a thermocouple positioned inside. This outside volume was sandwiched between two resistance wire heaters which could supply a known heat load \dot{Q} to the heat exchanger. Thermocouples at the water inlet and exhaust, along with the thermocouple positioned in the grease, determined the temperature drop ΔT from the outside heat load to the heat exchanger fluid. From this experimental configuration it was possible to determine a) whether or not the capillary tubes were a viscous bottleneck for the heat exchanger fluid (i.e., ΔP was too large) and b) a heat transfer coefficient h (a figure of merit for a heat exchanger) defined by

$$h = \frac{\dot{Q}}{A\Delta T} \quad (10)$$

where A is the total outside area of all of the capillary tubes involved in the heat exchanger.

The measurements of Δp as a function of U (for values from $\sim 9 \times 10^{-6}$ m³/s to 40×10^{-6} m³/s) revealed a quadratic dependence, with a level indicating that the pressure drop was dominated by turbulent flow in the large diameter tubes which carried the water to and from the capillary tube array; thus, as predicted by theory, the capillary array itself did not cause any significant impedance to the heat exchanger fluid flow. In fact, a comparison with a conventional TAR heat exchanger indicated that the capillary array heat exchanger, even with a higher heat carrying capacity, had a pressure drop which was about a factor of nine smaller than that of the conventional heat exchanger.

With a water flow rate of $U = 38 \times 10^{-6}$ m³/s, the measured value of the heat transfer coefficient h was 1.25×10^4 W/m²K. This measured coefficient only accounts for the heat transfer from the outside walls of the capillary tubes (in contact with the high thermal

conductivity grease) to the heat exchanger fluid; in a TAR, the heat transfer from the acoustic gas to the outside walls must be included. When the ASHE heat exchanger was tested in an actual TAR environment, it was found the heat transfer coefficient for the gas to the capillary tube walls was more than a factor of two smaller than the $1.25 \times 10^4 \text{W/m}^2\text{K}$ value for the capillary tube array. Thus the capillary tube heat exchanger has ample heat transfer capability for a TAR. Indeed, the tests in the TAR indicate that the capillary array heat exchanger is about a factor of five better than a conventional tube-and-fin TAR heat exchanger. The tests of the ASHE in a TAR are discussed next.

Tests of the anisotropic stack/heat-exchanger in a thermoacoustic refrigerator

It was decided that the best way to evaluate the new ASHE unit would be to compare its performance with that of a conventional stack and heat exchanger in an actual thermoacoustic refrigerator. To this end, an existing TAR, for which extensive measurements had been made with a conventional stack and heat exchanger, was obtained, and the stack and heat exchanger were removed and replaced with an ASHE unit. This existing TAR was the Space Thermoacoustic Refrigerator (STAR), a modular TAR developed by T. J. Hoffer, S. L. Garrett, and others at the Naval Postgraduate School in Monterey, CA. [5] The basic STAR acoustic resonator is illustrated in Fig. 8. An acoustic driver, not shown in the figure, would be attached to the flange on the left. Described in a simplified manner, the device is a plane wave resonator terminated on the right with a spherical Helmholtz resonator. It is about 10 cm in diameter and about 45 cm in length; its resonance frequency corresponds to fitting approximately one quarter acoustic wavelength inside the resonator.

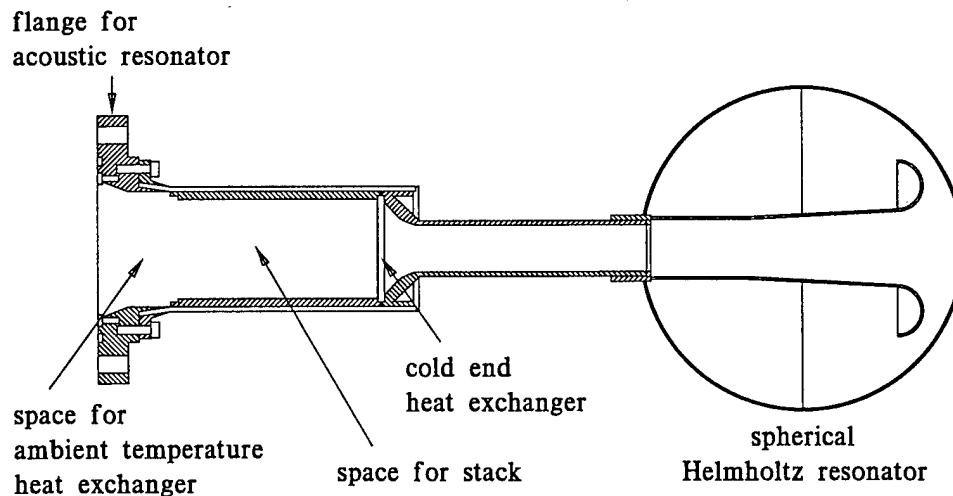

Figure 8. Space Thermo-Acoustic Refrigerator (STAR), developed by T. J. Hoffer, S. L. Garrett, and others at the Naval Postgraduate School in Monterey, CA. It is shown without the acoustic driver, stack, and one heat exchanger.

In Fig. 8 the STAR is shown without the stack and one heat exchanger. The original STAR had a conventional spiral-wound plastic sheet stack with copper fin heat exchangers at each end; the stack and heat exchangers were contained in the larger diameter cross-hatched region to the left in Fig. 8. At the ambient temperature end, nearest the driver flange on the left, the copper fins were soldered to copper refrigeration tubing carrying flowing water, essentially comprising a conventional "tube-and-fin" heat exchanger. The copper fins at the "cold end", just to the left of the tapered and reduced diameter region in the middle of the STAR, did not have a "tube with flowing water" thermal connection to a load to be cooled; for research purposes, it was only necessary to contact a copper ring surrounding the cold-end fins with a resistance wire heater, which could provide a known heat load.

In modifying the STAR for studies of the ASHE unit, it was not possible to remove the cold end copper fin heat exchanger, as this was permanently built into the acoustic resonator. Thus the ASHE unit built for study had only one capillary tube heat exchanger, used on the ambient temperature end; at the cold end, the end of the pin stack was simply pressed against the existing STAR copper fin heat exchanger. Thus the test of the ASHE unit was somewhat hampered. Nevertheless, it will be shown that the ASHE unit resulted in significant improvement, and even better performance is seen if a correction is made for the lack of the ASHE cold-end heat exchanger.

Quantifying the performance of the ASHE unit

Before continuing with a description of the tests of the ASHE unit in the TAR, it would be appropriate to discuss the means for assessing the performance of a refrigerator. A basic figure of merit for a refrigerator is the coefficient of performance (*COP*), defined as the ratio of the heat taken in at the cold end, *Q*, to the work *W* required to run the refrigerator:

$$COP = \frac{Q}{W} \quad (11)$$

In accordance with the Second Law of Thermodynamics, there can be no perfect refrigerator, and the value of the *COP* is limited. The maximum possible value would be that for a Carnot cycle refrigerator, with a *COP* given by

$$COP_{Carnot} = \frac{T_C}{T_A - T_C} \quad (12)$$

where T_C is the cold end temperature and T_A is the ambient temperature of the reservoir into which waste heat is exhausted (e.g., room temperature).

Since it is easier to compare quantities when they are normalized as a percent of a maximum possible, we shall rate the performance of a refrigerator with a coefficient of performance relative to Carnot, *COPR*, defined as

$$COPR = \frac{COP}{COP_{Carnot}} = \frac{Q/W}{T_C/(T_A - T_C)} \quad (13)$$

If one had a refrigerator with no friction or other mechanisms where energy is wasted, then only some minimum amount of work would be required to take in heat at the cold end. However, with paths where energy is wasted, W must be increased to overcome the waste, and from the formula just presented, the $COPR$ decreases. Typical home refrigerators, which have been perfected over many years, have a $COPR$ of $\sim 25\%$ (including all fans, pump, etc.).

In a TAR, thermal processes, occurring within the thermal penetration depth at the surfaces in the stack, produce the useful transfer of energy as heat. At the same time, friction (in the form of viscosity) resulting from the oscillatory motion of the acoustic gas occurring within a viscous penetration depth at the surfaces in the stack, results in wasted energy. Thus in an actual TAR, the $COPR$ is limited by an amount which depends on the ratio of viscous to thermal effects inside the stack. Incidentally, one the main advantage of the pin stack is that it has a geometry which can minimize this ratio. In any case, the existence of wasteful viscous effects as well as useful thermal effects inside a TAR stack results in an intrinsic limit to the $COPR$ of a thermoacoustic refrigerator.

In addition to the intrinsic viscous losses inside the stack, a TAR may have other wasteful energy losses occurring in the acoustic resonator outside of the stack. These losses may be estimated by measuring the quality factor, Q , of the acoustic resonator with the stack removed.

At this point another hindrance to a fair test of the ASHE unit should be mentioned. When the empty STAR resonator was tested, before inserting the ASHE unit, it was found to have a Q of 44. however, measurements of the Q made some years earlier found a Q of 56. Furthermore, the STAR resonator was found to have a number of small pin-hole leaks in the spherical part of the resonator. It was concluded that some corrosion, perhaps due to some acid flux remaining after soldering the stainless steel hemispheres, caused the pin-holes and left the inner surfaces of the spherical part rough; the rough surface would result in more energy loss and would reduce the Q . A reduced Q for the empty resonator would reduce the possible $COPR$, relative to that of the original STAR, which could be obtained with the ASHE unit. Thus for a fair evaluation of the ASHE, the $COPR$ found with the ASHE unit should be corrected to account for the corroded resonator. From the definition of the $COPR$ and conservation of energy, the corrected $COPR$ may be shown to be

$$COPR_{corr} = COPR + (1 - COPR) \frac{Q}{Q_R} \left(1 - \frac{Q_R}{Q_{R0}} \right) \quad (14)$$

where $COPR$ is the measured but uncorrected coefficient of performance of the STAR with the ASHE installed, Q is the quality factor of the STAR with the ASHE, Q_R is the quality factor of the empty but corroded STAR resonator, and Q_{R0} is the quality factor of the empty STAR resonator measured before the corrosion. From the experimentally measured values, it is found that the ASHE $COPR$ should be increased by an additive amount of at least 0.04.

As mentioned earlier, the measured performance of the ASHE unit was also hindered be-

cause it was not possible to remove the cold end heat exchanger and replace it with an ASHE capillary tube heat exchanger; only the ambient temperature heat exchanger could be replaced. The effect of a lower quality heat exchanger on the *COPR* is as follows. An ideal heat exchanger can maintain the temperature of thermal load at the lowest temperature of the refrigerator. However, an actual heat exchanger has a finite thermal resistance R , so then when heat is extracted from the load at a rate Q_C , a finite temperature difference ΔT develops between the lowest temperature of the refrigerator and the load, such that $\Delta T = RQ_C$. A finite temperature difference across the heat exchanger means that energy is being wasted at the rate $\Delta T Q_C / T$, and this reduces the *COPR*. In the formula for the *COPR* (Eq. (13)), the reduction may be incorporated by replacing the cold temperature with $T_C = T'_C + \Delta T$, where T'_C is the cold temperature at the end of the stack, before the heat exchanger. Experimentally it was found that the capillary tube heat exchanger had temperature drops ΔT which were at least a factor of two smaller than that of the copper fin heat exchanger. Thus, if a proper ASHE unit with two capillary tube heat exchangers had been used, then the cold temperature in Eq. (13) should be $T_C = T'_C + \Delta T/2$.

In the section discussing the experimental results for the *COPR*, both the correction for the reduced Q (due to corrosion) and the lack of a second capillary tube heat exchanger will be applied.

Installation of the ASHE unit into the existing TAR

The ASHE unit uses a flowing heat-exchanger fluid which passes through the capillary tube array inside the acoustic resonator, while the existing STAR simply used conduction through copper components to the outside of the resonator. Thus for the ambient temperature heat exchanger, where the capillary tube array replaced the copper fins of the STAR, an adapter flange with fluid transport channels had to be employed. The adapter is shown in Fig. 9a, and its installation into the STAR apparatus is shown in Fig. 9b. The fluid transport channel on one side of the flange is shown with dotted lines in Fig. 9; the channel connects a port on the side of the flange to a manifold sealed over the open ends of the heat-exchanger tubes discussed earlier.

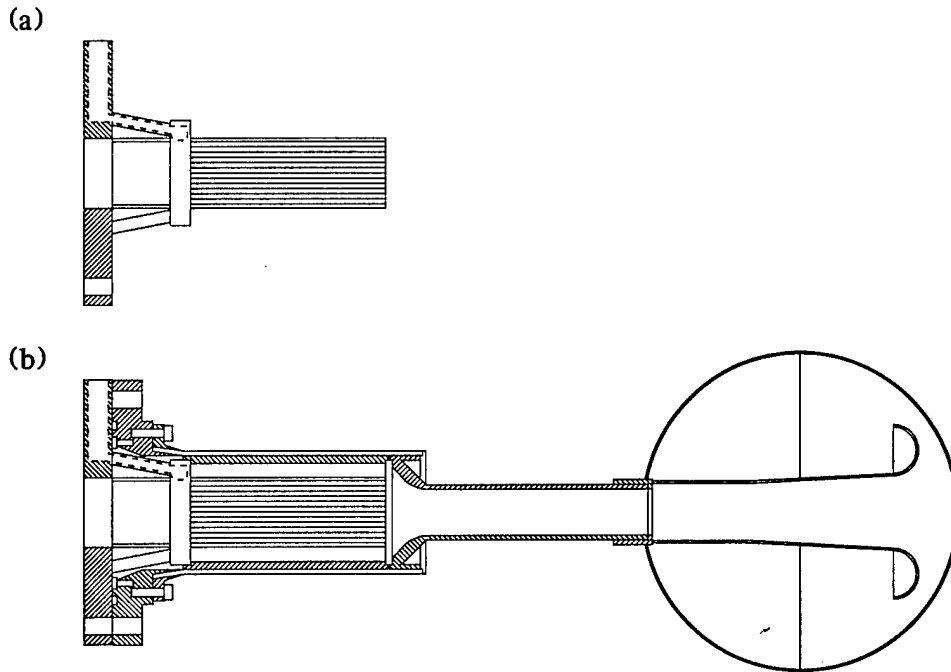

Figure 9. Space Thermo-Acoustic Refrigerator (STAR) and adapter for testing the anisotropic stack/heat-exchanger unit. a) Adapter. b) Adapter fitted into the existing STAR.

A photograph of a completed ASHE is shown in Fig. 10. The figure shows a plastic cylindrical form which fits inside the cylindrical bore of the STAR apparatus; the ASHE, with square cross section, is visible at the right end of the form.

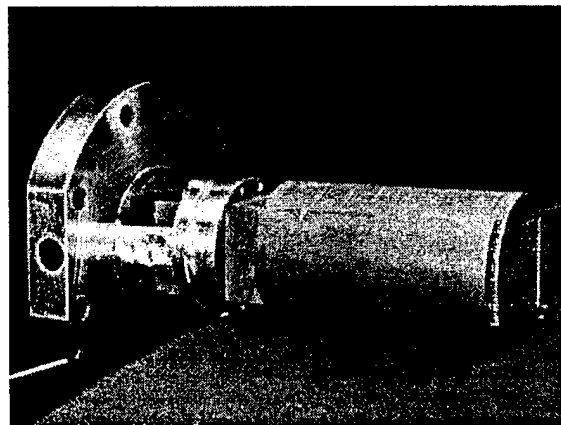

Figure 10. Photograph of a completed anisotropic stack/heat-exchanger (ASHE) unit, ready for insertion into the Space Thermo-Acoustic Refrigerator (STAR).

The Facility for Testing the New Stack/Heat-exchanger

Measurements of the performance of the ASHE unit in the STAR were made with the instrumentation illustrated in Fig. 11.

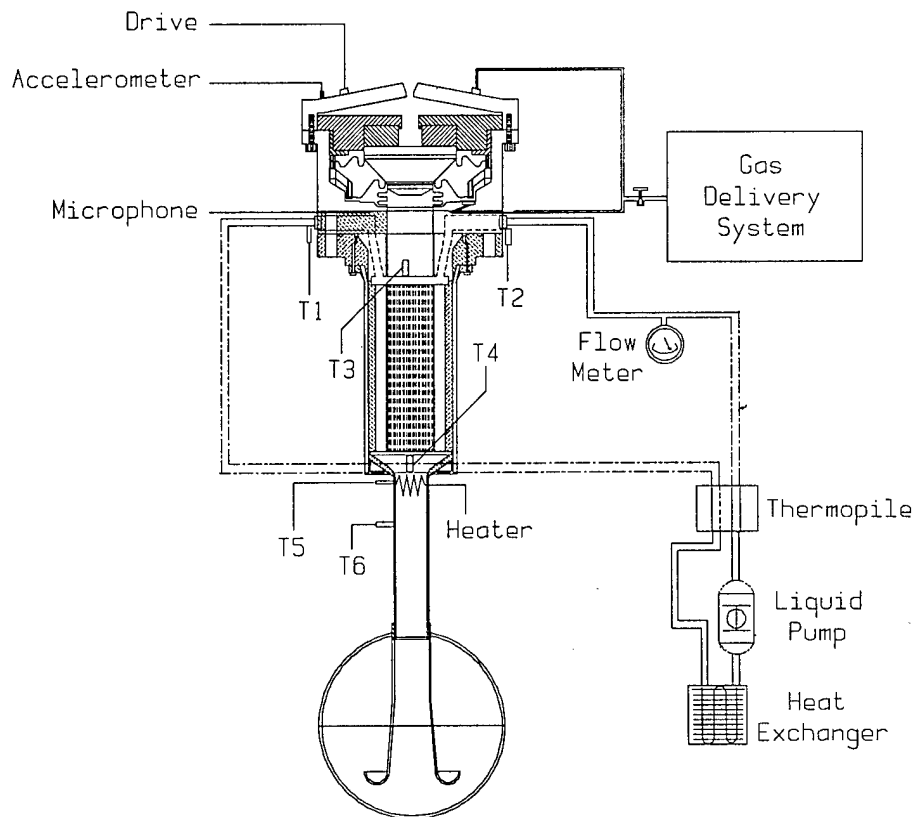

Fig. 11. The anisotropic stack/heat exchanger (ASHE) test facility. Components, instruments, etc. are explained in the text.

The TAR is activated with the electromechanical driver; by measuring the voltage and current at the coil of the driver, the input electrical power may be determined. The accelerometer indicated in Fig. 11 monitors the motion of the driven piston (bellows). The microphone measures the sound pressure generated at the driver. The microphone and accelerometer data together are used to determine the acoustic power W_A delivered to the TAR. The acoustic fluid is a high pressure mixture of 83% helium and 17% argon, supplied by the gas delivery system indicated in Fig. 11.

The ASHE ambient temperature capillary tube heat exchanger is maintained at room temperature with water supplied from a room-temperature external heat exchanger (using a large tank of water as a thermal reservoir), with pressure maintained with a variable speed liquid pump. The volume flow-rate of the water U is monitored with the flow meter indi-

cated in Fig. 11, and the difference in the inlet and outlet temperature ΔT_A is measured with a thermopile (consisting of ten differential pairs of thermocouples, connected in series to multiply the voltage signal). Using U , ΔT_A , and the heat capacity of water, the rate Q_A at which heat is being removed by the ASHE ambient temperature heat-exchanger may be determined. A test heat load Q_C for the TAR is provided with an electrical heater at the cold end of the stack; by monitoring the voltage and current at this heater, the heat load power may be determined.

Temperatures throughout the TAR are monitored with thermocouples T1 through T6. T1 and T2 measure the outlet and inlet temperatures of the ASHE integrated heat-exchanger; the difference (T1-T2) provides a redundant check on the measurement provided by the thermopile, and the average gives the mean temperature of the ASHE integrated heat-exchanger. T3 and T4 give the temperatures at the ambient (room temperature) and cold ends of the stack respectively. T5 is the temperature at the heat load, and T6 determines how much heat flows from the end of the TAR unit. A significant difference in T4 and T5 reflects the relatively high thermal resistance of the copper fin heat exchanger. As discussed earlier, a correction for not having a capillary tube heat exchanger at the cold end is made by using $T_5 - (T_5 - T_4)/2$ for the cold end temperature T_C .

All sensors were carefully calibrated. [6] Data from all instruments is logged with a multimeter computer interface and a dedicated computer. From such a complete set of sensors, the performance of the ASHE unit is readily determined.

Accuracy check using conservation of energy

In order to check the accuracy of the measurements, one may use the law of conservation of energy. That is, one must have that $W_A + Q_C = Q_A$. This may be checked by plotting Q_A versus $W_A + Q_C$ under varying conditions and determining the slope of a linear fit; the slope should be 1. In the ASHE tests a slope of .95 was found, indicating that not all of the power delivered by the acoustic driver and the heat load was being exhausted at the ambient temperature heat exchanger. However, the test apparatus was not perfectly isolated from the environment; i.e., some heat was lost to the surrounding air. In any case, the value of .95 indicates that the ASHE *COPR* tests should have an accuracy within 5%.

Results

Experimental measurements were made under a wide range of conditions. Data were taken with the acoustic pressure, expressed as a percent of the ambient pressure of the gas in the resonator, set at values of 2.0%, 2.6% and 3.0%; the acoustic power delivered to the TAR varied from about 4 W to 14 W. The heat load at the cold end was varied from 4 W to nearly 20 W, and the temperature at the cold end varied from -28 C to 5 C.

The conditions where the acoustic pressure was maximum provided the best test for the ASHE unit, for the cooling power and load on the heat exchanger was greatest in this case.

The detailed results for the case which yielded the best *COPR* are presented in the table below.

Parameter	Units	Conventional TAR	ASHE unit TAR
Ambient temperature T_A	K	293.4	293.4
Cold end temperature T_C	K	250.6	250.6
Acoustic power W_A	W	11.1	11.1
Cold end load Q_C	W	11.9	11.9
Heat exchanger:			
Water flow rate U	10^{-4} m ³ /s	0.11	0.44
Pressure drop Δp	psi	9.1	1.18
Waste power $\Delta p U$	W	0.70	0.36
Temperature drop ΔT	K	8.2	3.9
Waste power due to ΔT	W	0.32	0.15
Total waste power	W	1.02	0.51
Test acoustic pressure			
relative to gas pressure	%	3.0	3.0
<i>COPR</i>	%	10	22

The comparison of the conventional and ASHE heat exchangers is made assuming the following conditions: the heat exchangers are at the same ambient temperature (293.4 K), and have a heat load which is the average of that of the ambient and cold end, $(11.1 + 11.9)/2 = 11.5$ W. The values for the conventional heat exchanger are estimates for the existing STAR copper fin heat exchanger, as well as for another tube-and-fin TAR heat exchanger. [7]

From the table, it can be seen that the ASHE unit, in all respects, surpasses the conventional TAR stack and heat exchanger by about a factor of two.

References

- [1] G. W. Swift, *J. Acoust. Soc. Am.* **84**, 1145 (1988). Thermoacoustic engines.
- [2] G. W. Swift, *Physics Today*, July 1995, p. 22.
- [3] U. A. Mueller, "Thermoacoustic devices", U. S. Patent No. 4,625,517 (December, 1986).
- [4] G. W. Swift and R. M. Keolian, "A thermoacoustic pin stack for improved efficiency", U. S. Patent 5,456,082 (October 10, 1995).
- [5] S. L. Garrett, J.A. Adeff, and T. J. Hofer, "Thermoacoustic refrigerator for space applications", *J. Thermophysics and Heat Transfer (AIAA)* **7**, 595-599 (1993).

- [6] David Chao Zhang, "Design and study of an anisotropic stack/heat-exchanger for a thermoacoustic refrigerator", Ph.D. thesis, The Pennsylvania State University, 2001.
- [7] S. L. Garrett, D. K. Perkins, and A. Gopinath, "Thermoacoustic refrigerator heat exchangers: design, analysis, and fabrication", in Heat Transfer 1994, Proc. 10th Int. Heat Transfer Conf. Vol. IV, 375-380 (1994), ed. G. H. Hewitt