

Wavelet Multiscale Edge Detection Using An ADALINE Neural Network To Match Up Edge Indicators

Marlin L. Gendron, Naval Research Laboratory, Stennis Space Center, MS
James A. Hammack, Naval Oceanographic Office, Stennis Space Center, MS

Abstract

The detection of sudden changes or discontinuities in data is an important issue in digital image processing. Such changes are often referred to as edge information or just edges. Finding edges are essential to many scientific areas ranging from computer vision to target detection. Not only must the detector be able to find the edges, but it must also be able to detect them in the presence of noise. Many edge-detecting algorithms perform well, but many times these algorithms break down in noisy conditions. One possible solution is to take advantage of the multiscale nature of the wavelet transform to detect edges in noisy conditions. This paper explores one possible method of extracting edge information in two-dimensional sidescan acoustic backscatter imagery using a Wavelet Multiscale Edge Detector (WMED). The WMED uses a wavelet transform to generate coefficients and break down a signal into frequency bands at different levels. Scaling a wavelet, or short waveform, with a scale factor and shifting its position produces these levels. Noise present at low levels is smoothed out and disappears at higher levels. The WMED exams and matches up large magnitude high frequency coefficients, called local maxima, over many different levels to detect edges. To enhance the ability of the detector to operate in very noisy conditions, the WMED is modified to use an ADALINE (ADaptive LInear NEuron) neural network that adapts to match up edge indicators across multiple wavelet levels. The ADALINE uses the least mean squared (LMS) learning rule to minimize the mean square error. The LMS algorithm is able to optimize the decision boundaries of the network. This makes the boundaries more effective in the presence of noise. This paper will test the capability of the ADALINE to match up the edge indicators in noisy two-dimensional sidescan imagery.

Acknowledgments

This work was funded by SPAWAR Code PMW185 (Program Element: #0603207N). We wish to acknowledge Dr. Edward Mozley and support from the bottom mapping team at the Naval Oceanographic Office.

Introduction

The detection of sudden changes or discontinuities in data is an important issue in digital image processing. Such changes are often referred to as edge information or just edges. Finding edges is essential to many scientific areas ranging from computer vision and computer graphics to target detection (Meek, 1990). Not only must the detector be able to find the edges, but also it must be able to detect them in the presence of noise. Many edge-detecting algorithms perform well, like the popular Canny algorithm (Canny, 1986), but many times these algorithms break down in noisy conditions. One possible solution is to utilize the multiscale nature of the wavelet transform to detect edges in noisy conditions.

This paper explores the use of an ADALINE neural network to improve the performance of a Wavelet Multiscale Edge Detector (WMED) (H. Hajj, T. Nguyen, and R. Chin, 1996a). The WMED studied in this paper detects peaks (or indicators) at each wavelet level. The consistency between the indicators at all scales allows the edge locations to be detected. This allows the detector to operate in very noisy conditions (Strang and Nguyen, 1996).

To enhance this ability, the WMED is modified to use an ADALINE (ADaptive LInear NEuron) network (Figure 1) to match up edge indicators across multiple wavelet levels.

REPORT DOCUMENTATION PAGE

Form Approved OMB No.
0704-0188

Public reporting burden for this collection of information is estimated to average 1 hour per response, including the time for reviewing instructions, searching existing data sources, gathering and maintaining the data needed, and completing and reviewing this collection of information. Send comments regarding this burden estimate or any other aspect of this collection of information, including suggestions for reducing this burden to Department of Defense, Washington Headquarters Services, Directorate for Information Operations and Reports (0704-0188), 1215 Jefferson Davis Highway, Suite 1204, Arlington, VA 22202-4302. Respondents should be aware that notwithstanding any other provision of law, no person shall be subject to any penalty for failing to comply with a collection of information if it does not display a currently valid OMB control number. PLEASE DO NOT RETURN YOUR FORM TO THE ABOVE ADDRESS.

1. REPORT DATE (DD-MM-YYYY) 14-12-2001	2. REPORT TYPE Conference Proceedings	3. DATES COVERED (FROM - TO) xx-xx-2001 to xx-xx-2001
---	--	--

4. TITLE AND SUBTITLE Wavelet Multi-Scale Edge Detection Using An Adaline Neural Network To Match Up Edge Indicators Unclassified	5a. CONTRACT NUMBER
	5b. GRANT NUMBER
	5c. PROGRAM ELEMENT NUMBER

6. AUTHOR(S) Gendron, Marlin ; Hammack, James ;	5d. PROJECT NUMBER
	5e. TASK NUMBER
	5f. WORK UNIT NUMBER

7. PERFORMING ORGANIZATION NAME AND ADDRESS Naval Research Laboratory Marine Geoscience Division Stennis Space Center, MS39529-5004	8. PERFORMING ORGANIZATION REPORT NUMBER
--	--

9. SPONSORING/MONITORING AGENCY NAME AND ADDRESS Spawar PMW 155 4301 Pacific Highway San Diego, CA92110	10. SPONSOR/MONITOR'S ACRONYM(S)
	11. SPONSOR/MONITOR'S REPORT NUMBER(S)

12. DISTRIBUTION/AVAILABILITY STATEMENT APUBLIC RELEASE
--

13. SUPPLEMENTARY NOTES Please delete SF298 that came with document and use the one put in with electronic copy of document. It is a poor copy.
--

14. ABSTRACT The detection of sudden changes or discontinuities in data is an important issue in digital image processing. Such changes are often referred to as edge information or just edges. Finding edges are essential to many scientific areas ranging from computer vision to target detection. Not only must the detector be able to find the edges, but it must also be able to detect them in the presence of noise. Many edge-detecting algorithms perform well, but many times these algorithms break down in noisy conditions. One possible solution is to take advantage of the multiscale nature of the wavelet transform to detect edges in noisy conditions. This paper explores one possible method of extracting edge information in two-dimensional sidescan acoustic backscatter imagery using a Wavelet Multiscale Edge Detector (WMED). The WMED uses a wavelet transform to generate coefficients and break down a signal into frequency bands at different levels. Scaling a wavelet, or short waveform, with a scale factor and shifting its position produces these levels. Noise present at low levels is smoothed out and disappears at higher levels. The WMED exams and matches up large magnitude high frequency coefficients, called local maxima, over many different levels to detect edges. To enhance the ability of the detector to operate in very noisy conditions, the WMED is modified to use an ADALINE (ADaptive LInear NEuron) neural network that adapts to match up edge indicators across multiple wavelet levels. The ADALINE uses the least mean squared (LMS) learning rule to minimize the mean square error. The LMS algorithm is able to optimize the decision boundaries of the network. This makes the boundaries more effective in the presence of noise. This paper will test the capability of the ADALINE to match up the edge indicators in noisy two-dimensional sidescan imagery.
--

15. SUBJECT TERMS edge information; adaline neural network

16. SECURITY CLASSIFICATION OF:	17. LIMITATION OF ABSTRACT Public Release	18. NUMBER OF PAGES 6	19. NAME OF RESPONSIBLE PERSON Fenster, Lynn lfenster@dtic.mil
---------------------------------	--	--------------------------	--

a. REPORT Unclassified	b. ABSTRACT Unclassified	c. THIS PAGE Unclassified	19b. TELEPHONE NUMBER International Area Code Area Code Telephone Number 703767-9007 DSN 427-9007
---------------------------	-----------------------------	------------------------------	--

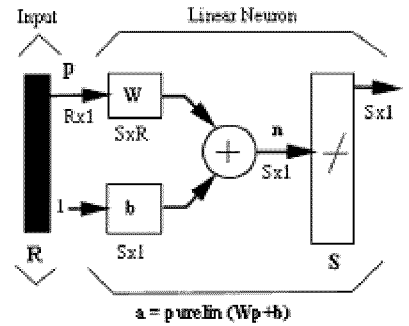

FIGURE 1

Wavelet Multiscale Edge Detector

A wavelet is a function short in duration with an average value of zero. The WMED in this paper uses one of the simplest wavelets, the Haar (Figure 5). From the wavelet, low and highpass filters are obtained. The highpass filter is a moving difference filter capable of detecting sharp changes in the data, and the lowpass filter is a moving average filter that smoothes the data. The high and lowpass filters, referred to as the “approximation” and “detail” coefficients respectively, are convolved with the input signal to produce coefficients called level one coefficients (Strang and Nguyen, 1996). There are twice as many coefficients in the output because the input signal was convolved with the two filters. Removing every other coefficient, or downsampling, the output corrects this problem, and the coefficients’ position in time relates directly back to the input signal (Hwang and Chang, 1996; Hajj, Nguyen, and Chin, 1996a).

The wavelet filters can then be rescaled, shifted, (Figure 5) and applied to the level one coefficients to produce level two coefficients (Figure 2). Downsampling occurs again and so on to produce more levels. The successive level coefficients are lower in resolution than the preceding level coefficients, but still maintain their position relative to the original time series (Misiti and Misiti, 1996). The WMED examines the detail coefficients from many levels, five in this case, to find edges (Figure 3). Groups of large magnitude detail coefficients, called local maxima, possibly define edges and small detail coefficients are likely to represent noise and should be removed. (Hwang and Chang, 1996).

The Wavelet Multiscale Edge Detector (WMED) can be extended to two dimensions (2-D) by scanning individual rows and columns of an image. Each scanline passes through the one-dimensional WMED to form a binary map. Row scanlines detect vertical edges, and column scanlines detect horizontal edges. By combining the two sets of edges into a two-dimensional binary map, all possible edges emerge including diagonal ones. Figure 4 shows the 2-D WMED (Hajj, Nguyen, and Chin, 1996b).

Because random white noise present at high resolutions tends to smooth out at lower resolutions, the time-scale (spatial-scale) properties of the wavelet transform can be used to extract true features in a noisy image. Peaks detected in lower level coefficients that are not present in upper levels are thrown out as noise. Peaks spatially close at all or most levels are kept as true edges. This is the basic concept behind the WMED (Hajj, Nguyen, and Chin, 1996a).

For this paper, detail coefficients at each level below a hard threshold are set to -1, and coefficients above are changed to a value of 1. A 1 denotes that an edge exists and a -1 denotes that it does not. A simple search algorithm was used to match up edge indicators across levels that are spatially close. This is tested and then the algorithm was replaced with an ADALINE neural network to match up indicators. The two methods are then compared.

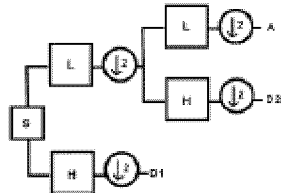

FIGURE 2

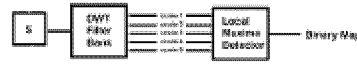

FIGURE 3

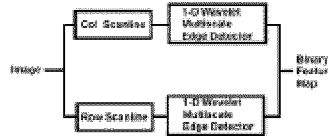

FIGURE 4

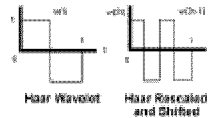

FIGURE 5

ADALINE

The ADALINE uses the least mean squared (LMS) learning rule to minimize the mean square error. The LMS algorithm is able to optimize the decision boundaries of the network. This makes the boundaries more effective in the presents of noise (Hagan, Demuth, and Beale, 1996). This paper will test the capability of the ADALINE to match up the edge indicators of noisy two-dimensional images.

Neural networks are algorithms implemented in software or hardware that attempt to mimic the way the human brain processes information. By internally adapting weights, the network can “learn” and solve complicated problems. To accomplish this adaptation the neural network is not programmed, but trained. Neural networks are used in visual recognition, sound recognition, data mining and image processing.

Researchers have put forth theories that govern the way neural networks are trained. These “learning rules” describe how the network adapts weights that are then multiplied with the input to produce an output. The output then passes though a linear or nonlinear transfer function. The particular transfer function used depends on the problem the network is trying to solve. (Hagan, Demuth, and Beale, 1996).

One of the most powerful learning rules in neurocomputing is the Widrow-Hoff learning rules. It attempt to find a set of weights that minimize the error in terms of a least mean squared (LMS) performance function (Hecht and Nielsen, 1990). In the late 50’s, Bernard Widrow and Ted Hoff put forth the simple ADALINE neural network shown in Figure 1.

The Widrow-Hoff algorithm is important for two reasons. First it is used extensively today in many signal-processing applications. It is also the forerunner to the back propagation algorithm for multilayer networks. If we compare the ADALINE to the perceptron learning rule we see that the former uses a transfer function that in linear instead of hard limiting. Both the ADALINE and the perceptron however experience a similar limitation in that they can only solve linearly separable problems. This problem can be overcome by using two or more networks combined together (called layers). A single layer ADALINE was used in this paper because the matching up of indicators is a linearly separable problem.

The ADALINE network must be trained before it can be used to solve a problem. To train the ADALINE to match up indicators across scales, first the indictors are grouped into sets of five columns. A window five columns wide is slid over the indicators. If spatially close indicators appear in the center column (column 3) in all levels, the output [-1 -1 1 -1 -1] is produced indicating an edge, otherwise no edge is present. The window is then moved over one pixel in the data space and five more columns processed. Note in any given iteration, four columns will be the same as the previous iterations, except for the first iteration.

This procedure is repeated until all the columns of the five levels of indicators are processed. This roughly works out to be 128 divided by 5 moves of the window in a 128 column data set.

To train the ADALINE, twenty-six patterns were generated. Figure 6 shows the pattern of training vectors. Note that zeros appear in the figure. In the real training set these values are -1, but are indicated here as 0's so the reader might see the patterns more easily.

P						T
10000	00010	01000	00100	00001		00100
10000	00010	01000	00100	00001		00100
10000	00010	01000	00100	00001	=	00100
10000	00010	01000	00100	00001		00100
10000	00010	01000	00100	00001		00100
00000	00000	00000	00000	00000		00000
10000	01000	00100	00010	00001		00000
10000	01000	00100	00010	00001	=	00000
10000	01000	00100	00010	00001		00000
10000	01000	00100	00010	00001		00000
⋮						
⋮						
00000	00000	00000	00000	00000		00000
00000	00000	00000	00000	00000		00000
00000	00000	00000	00000	00000	=	00000
00000	00000	00000	00000	00000		00000
10000	01000	00100	00010	00001		00000

FIGURE 6

The input (p's) were combined into one matrix P and targets (t's) combined into one matrix T. The P's and T's were feed into the ADALINE and after 70 iterations, the error was minimized, and the network was trained. The initial 5x25 weight matrix W contained only zeros. Initialing the weight matrix to random values was also tested, but the final WMED results were inferior to zero initiation.

Once trained, the network was tested on noisy five by five patterns likely to be seen in the actual data. These tests showed that the network was able to sufficiently match up spatially close indicators across five levels. The ADALINE was then incorporated into the WMED and tested on a noisy sidescan image of sand waves.

Testing

The WMED and ADALINE are developed in three steps and tested on many data sets. The first step is to determine which wavelet best detects edges when incorporated into the WMED scheme. The wavelet must have discrete filters for computer digital processing, and the choice of scales is dyadic. The Daubechies 4 and 6 wavelets are tested (results not shown in this paper), but the Haar wavelet is chosen for its edge detection abilities in the presence of noise. This decision is supported by previous wavelet multiscale edge detection research (Hajj, Nguyen, and Chin, 1996a).

The second step is to determine the best way to match up indicators over several levels. To accomplish this, indicators of the feature must be located at all levels, especially in the first level. The rule for tracing edges across levels is to connect an indicator at the lowest level to the indicator at the same location at the higher levels. If indicators are found at all levels, it is considered an edge. Therefore, all edges must be detected in the level one detail coefficients or edges are lost.

Figure 7 shows an image of sand waves used to test the two-dimensional WMED. The image is used to test three edge detection algorithms, the Canny, the WMED, and the WMED with the ADALINE network. First, the sand wave image is run through the Canny algorithm with a threshold of 0.5. The resulting edges are shown in Figure 8.

Next, the WMED was tried on the same image. Five high frequency coefficient levels were used and indicators were matched up over a 5 pixel wide range. A hard threshold of 0.5 was applied. The resulting image is shown in Figure 9. Figure 10 shows the results of the WMED using the trained ADALINE. A threshold of 0.5, five levels and a pixel range of 5.

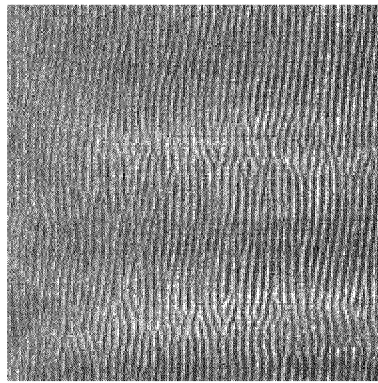

FIGURE 7

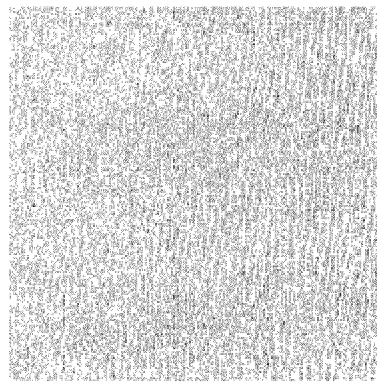

FIGURE 8

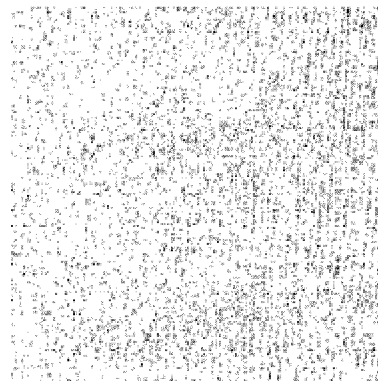

FIGURE 9

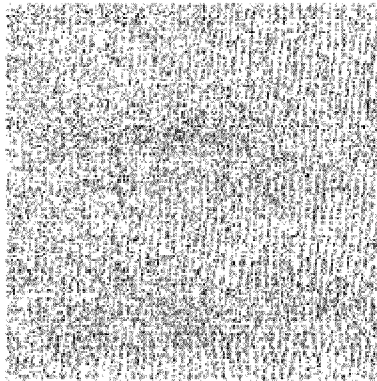

FIGURE 10

Conclusion

Two methods for extraction of edges from a noisy two-dimensional image are presented. The WMED detectors not only found the edges, but also detected them well in noisy conditions. A relatively new tool in image processing, the wavelet transform, lends its multi-resolution capabilities to the problem. Unlike the Fourier transform, use of wavelets allows analysis of signals in the frequency domain while retaining time or spatial information. This time-scale (spatial-scale) property of wavelets is utilized in the Wavelet Multiscale Edge Detector (WMED) to detect edges in noisy conditions. The adaptive nature and noise fighting characteristics of the ADALINE network is added to the WMED and tested.

Note that more edges were detected when using the WMED over the Canny. The WMED edges remain uncluttered. Interestingly, not all the edges were detected, but the ones that are present are smoother and better defined. By using a smaller threshold, more edges could have been recovered, but this adds more false detections throughout the edge image. Even at a smaller threshold, the edges remain well defined. On the other hand, by raising the threshold in the case of the Canny edge image, edge information is lost, but the remaining edges still remain cluttered. The results of this paper are interesting and further study is needed to evaluate the complete ability a neural network to match up edge indicators in the WMED.

References

- J. Canny, 1986, "A Computational Approach to Edge Detection," IEEE Trans. Pattern Analysis and Machine Intelligence, 8, 679-698.
- J. Hager, L. Fry, S. Jacks, and D. Hill (1990). "Datums, Ellipsoids, Grids, and Grid Reference Systems," Defense Mapping Agency, TM8358.1.
- H. Hajj, T. Nguyen, and R. Chin, 1996a, "On Multi-Scale Feature Detection Using Filter Banks," IEEE Trans. on Sig. Proc., 1, 70-74.
- H. Hajj, T. Nguyen, and R. Chin, 1996b, "A 2D Multirate Bayesian Framework for Multiscale Feature Detection," Proceedings of the SPIE - The International Society for Optical Engineering, 2825, 330-341.
- R. Hecht-Nielsen, 1990, "Neurocomputing," Addison-Wesley Publishing Company.
- W. Hwang and F. Chang, 1996, "Character extraction from documents using wavelet maxima," SPIE, 2825, 1003-1015.
- H. Meek, 1990, "Target detection using a three-layered neural network trained by supervised back-propagation," SCALANT Undersea Research Centre.
- M. Misiti and Y. Misiti, 1996, "Wavelet Toolbox," The Math Works Inc.
- G. Strang and T. Nguyen, 1996, "Wavelets and Filter Banks," Wellesley-Cambridge Press.