

**REPORT DOCUMENTATION PAGE**

AFRL-SR-BL-TR-02-

Public reporting burden for this collection of information is estimated to average 1 hour per response, including the time for reviewing the collection of information, gathering and maintaining the data needed, and completing and reviewing the collection of information, including suggestions for reducing this burden, to Washington, DC 20503.

Reporting data any other forms and 04-0188)

0142

1. AGENCY USE ONLY (Leave blank)	2. REPORT DATE	3. REPORT PERIOD DATES COVERED 15 Jul 97 to 14 Jan 01 FINAL
----------------------------------	----------------	--

4. TITLE AND SUBTITLE Femtosecond Wavelength Division Multiplexed Interconnect using smart pixel technology	5. FUNDING NUMBERS 61101E D107/33
--	---

6. AUTHOR(S) Professor Miller	
----------------------------------	--

7. PERFORMING ORGANIZATION NAME(S) AND ADDRESS(ES) Stanford University 450 Via Palou Stanford, CA 94305-4085	8. PERFORMING ORGANIZATION REPORT NUMBER
---	--

9. SPONSORING/MONITORING AGENCY NAME(S) AND ADDRESS(ES) AFOSR/NE 801 North Randolph Street Rm 732 Arlington, VA 22203-1977	10. SPONSORING/MONITORING AGENCY REPORT NUMBER  F49620-97-1-0517
---	--

11. SUPPLEMENTARY NOTES
-------------------------

12a. DISTRIBUTION AVAILABILITY STATEMENT APPROVAL FOR PUBLIC RELEASE; DISTRIBUTION UNLIMITED	12b. DISTRIBUTION CODE AIR FORCE OFFICE OF SCIENTIFIC RESEARCH (AFOSR) NOTICE OF TRANSMITTAL DTIC. THIS TECHNICAL REPORT HAS BEEN REVIEWED AND IS APPROVED FOR PUBLIC RELEASE LAW AFR 190-12. DISTRIBUTION IS UNLIMITED.
---	--

13. ABSTRACT (Maximum 200 words)  A short pulse based optical link was demonstrated. It was shown that the short pulse link can remove up to half a bit of skew and jitter from the transmitter. Optoelectronic devices were fabricated and integrated to silicon chips in-house. A first generation wavelength division multiplexed optical link with short pulses was demonstrated and a second generation wavelength division multiplexed optical link system is described. Results are also shown for the testing of individual circuits and devices.
---

**20020419 173**

14. SUBJECT TERMS	15. NUMBER OF PAGES
	16. PRICE CODE

17. SECURITY CLASSIFICATION OF REPORT UNCLASSIFIED	18. SECURITY CLASSIFICATION OF THIS PAGE UNCLASSIFIED	19. SECURITY CLASSIFICATION OF ABSTRACT UNCLASSIFIED	20. LIMITATION OF ABSTRACT UL
---	--	---	----------------------------------

NE

Final Report  
to  
The Air Force Office of Scientific Research (AFOSR)  
for a program of research entitled:

**FEMTOSECOND WAVELENGTH DIVISION MULTIPLEXED  
INTERCONNECT USING SMART PIXEL TECHNOLOGY**

Contract No. F49620-97-1-0517  
July 15, 1997 through January 14, 2001

Edward L. Ginzton Laboratory  
450 Via Palou  
Stanford University  
Stanford, CA 94305-4085

FEB 11 2002  
RECEIVED



## I. Introduction

Optical interconnects are gaining wide acceptance for links longer than a few meters. The throughput, the latency, and the power consumption of the existing links need to be improved to support the requirements of the current systems. Wavelength division multiplexing (WDM) can potentially increase the total throughput in a single fiber while eliminating the need for high-speed electronics. The latency of the link can also be reduced by using WDM.

The goal of this work is to demonstrate a chip to chip link using wavelength division multiplexing based on short pulses. Traditional WDM systems use a separate laser for each channel. The wavelength of each laser must be stable, which requires complex monitoring and control. In the present work, we use the large bandwidth of short pulses to generate multiple wavelength channels. GaAs based optical devices are hybrid integrated on silicon CMOS (complementary metal oxide semiconductor) circuits in large arrays. Details of the devices and the integration scheme are given in the next section.

## II. Devices for Optical Interconnects

The optical device used in this project is a  $p-i-n$  diode with quantum wells in the  $i$  region. The structure of this diode is shown in figure.1. The main advantage of this structure is that it can be used as both a modulator and a photodiode.

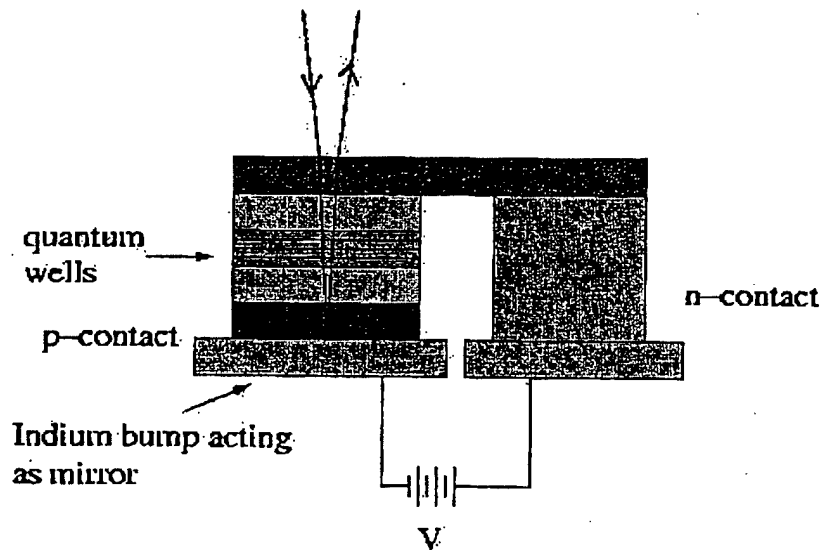

Figure1: GaAs modulator, in which absorption is modulated by changing the voltage V

As a modulator, this device works on the principle of the quantum confined stark effect; That is, the absorption peak can be shifted by changing the voltage across the device. A laser beam incident on the device is reflected by the indium bump, that acts as a mirror. By changing the voltage across the diode, the state of the device is changed from absorbing to non-absorbing for the incident wavelength modulating the incident light beam. This effect is illustrated in figure.2. If the diode is connected in such a way that the

voltage across it can be changed, it acts as a modulator. If it is connected with a constant reverse bias, the device acts as a photodiode.

**Wafer 646: Absorption vs. Wavelength**

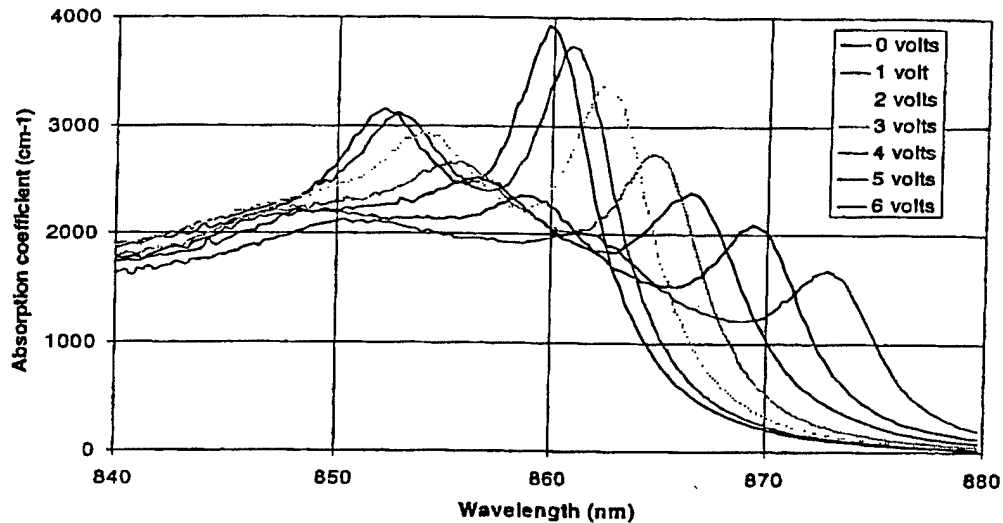

Figure 2: Plot of the absorption spectrum of modulator at different voltage bias

In these experiments, the voltage swing used across the modulators is 3V. The ratio of the reflected light intensity for the two voltage levels is approximately 2:1. To improve the performance of the circuits, the modulator is used in a differential manner, effectively doubling the swing.

### III. Hybrid Integration

Silicon foundries are very advanced and the cost of fabricating circuits in silicon is very low. The optical devices, however, cannot be fabricated in silicon. One would like to grow GaAs devices monolithically on silicon, but for various reasons this is not currently practical. First, due to the lattice mismatch at the boundary of GaAs and silicon, many defects are introduced. Second, introducing GaAs in a well established silicon foundry may be unacceptable due to contamination issues. To take advantage of the advanced silicon circuits as well as the optical properties of GaAs devices, a technique called "hybrid integration" can be used. In this technique silicon circuits are fabricated separately from GaAs devices and they are integrated later. The process of hybrid integration is also referred to as flip chip bonding. Figure 3 shows a cartoon of the flip chip bonding process and figure 4 shows the bonded devices. Hybrid integration reduces the capacitance of the devices seen by the circuits, improving their performance. Very high yields have been demonstrated for hybrid integration.

Silicon CMOS chip with gold bonding pads

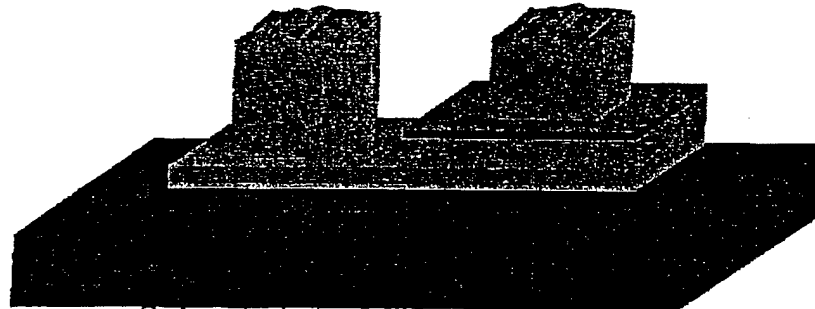
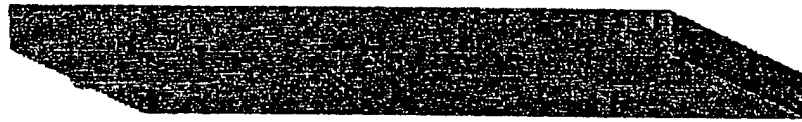

GaAs optoelectronic chip with indium flip-chip bumps

Figure 3: Flip chip bonding of silicon circuits to GaAs devices

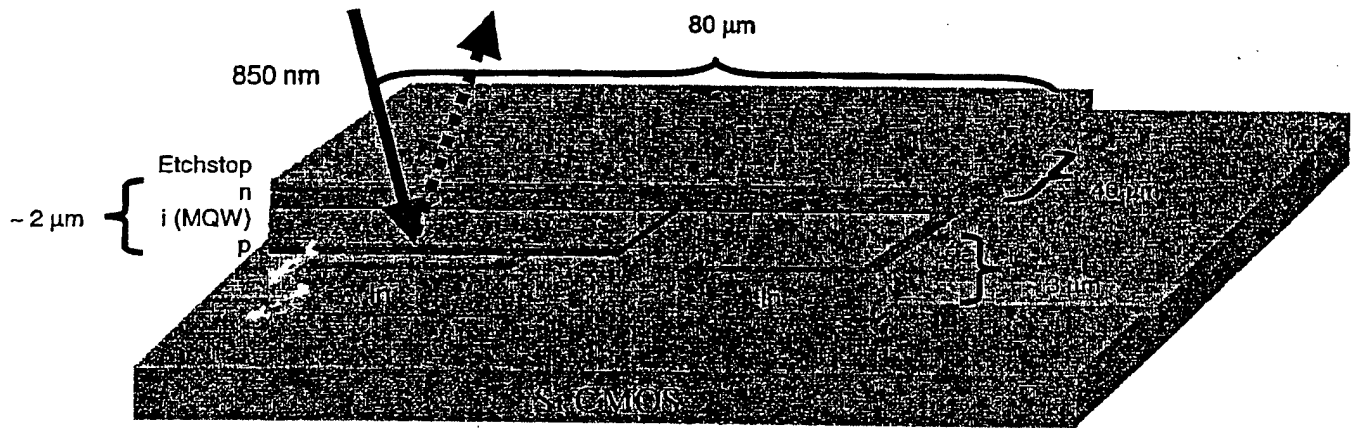

Figure 4: Optical device flip chip bonded to silicon circuit

#### IV. Baseplate Test Setup

Before a full system demonstration of the WDM system, the circuits and integrated devices were tested on slotted stainless steel baseplates. The advantage of this system is easy reconfigurability. Easy reconfiguration allows multiple small demonstrations leading to a better design of the WDM system.

Figure 5 shows a picture of the chip to chip test setup using baseplates. A laser beam is split into multiple spots by a spot array generator. These spots are modulated by a row of modulators on the chip. These modulated data beams are then imaged onto the receiver

chip where the detected data is converted to CMOS logic levels, then retransmitted on a neighboring modulator. This modulator state can be read out by another laser beam to compare the data with the original data to check for transmission errors. An eye diagram at the output of the receivers can also be generated. This method of read out eliminates the need for high-speed electrical pins.

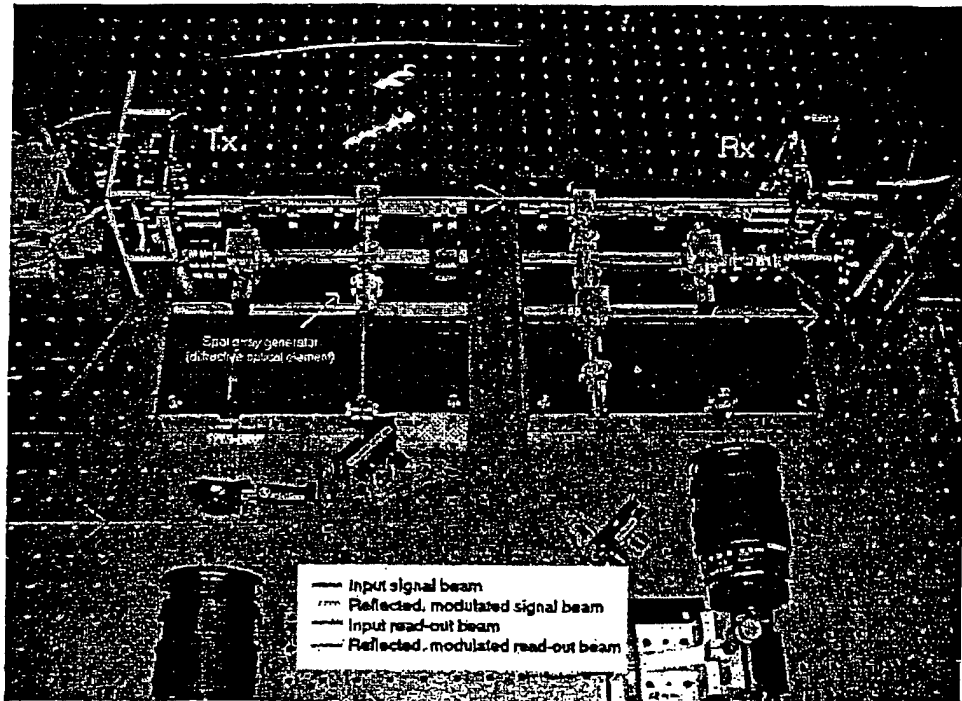

Figure 5: Chip to chip interconnect on slotted stainless steel baeplates

## V. Short pulse-based WDM optical interconnect

The schematic in figure 6 shows the principle of operation of the WDM system. Short optical pulses (100 femtoseconds), generated by a Ti:Sapphire mode-locked laser, are dispersed by the grating into a wavelength spread in space. A lens collimates the different wavelengths, which are then incident on the array of modulators. Each modulator modulates a small band of wavelengths. The separation between modulators corresponds to the guard band between channels. The modulated light is reflected back to the grating where it is again combined into a single beam. A single mode fiber transports this beam to the destination. A grating again disperses the beam into a spatial wavelength spread. The modulated channels are put on the corresponding receiver diodes. Received data is converted to a full logic swing by the receiver.

Advantages of using short pulses in the system are enumerated below:

1. Short pulses provide a single source for different wavelength channels. Unlike traditional WDM schemes where different lasers generate different wavelengths, the channel separation is determined by the modulator spacing. The need of a careful

- monitoring to maintain the right wavelength spacing is eliminated by using short optical pulses.
2. Optical pulses are much shorter than the electrical bit period, and they effectively sample the data on the modulator. Skew and jitter between different channels on the transmitter side can be eliminated if the pulses sample the data in the center of the bit. This demonstration is shown in the next section.
  3. Short optical pulses improve the performance of the transimpedance receiver by enhancing its sensitivity.
  4. Latency in the receiver can possibly be reduced by using short optical pulses because all the energy is dumped in a single instant. This contrasts the standard approach, in which the slow rising edges of the non-return to zero data, take longer to charge the internal nodes of the receiver.
  5. Short pulses can be used to deliver a precise clock synchronized to the data.

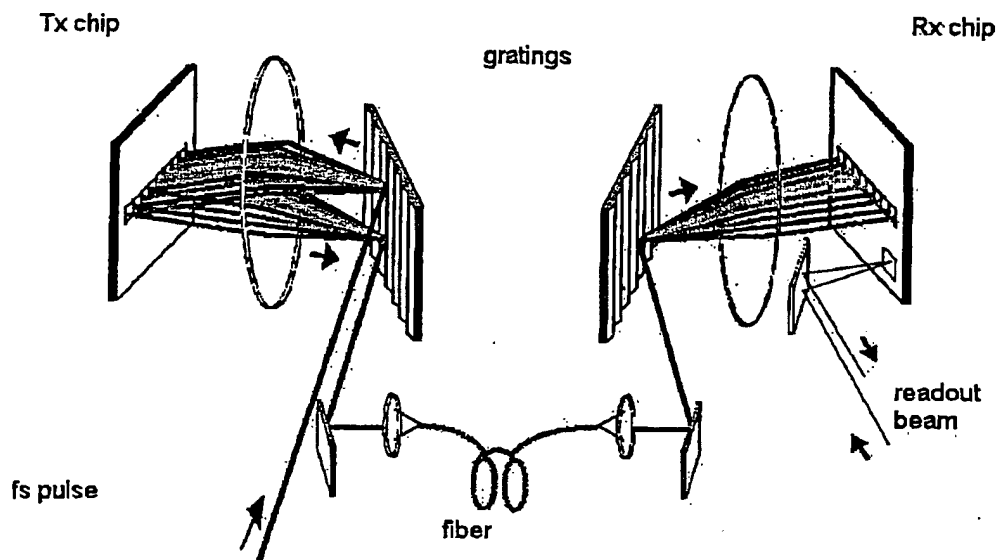

Figure 6: Schematic representation of WDM optical link

### ***First generation WDM link***

The first generation silicon chips were fabricated through MOSIS and the optical devices were integrated by Lucent Technologies. The chip was fabricated in  $0.5\mu\text{m}$  technology. The layout of the silicon CMOS chip is shown in figure 7. The chip has a  $1 \times 20$  array of modulators driven by a pseudo random data generator. Modulators are connected in a differential fashion and two modulators define a channel. Transimpedance receivers were placed on the chip to receive the data. The chip also consists of a bit error rate tester utilizing the knowledge of the logic used in the pseudo random data generator. Two receivers are connected to the bit error rate (BER) tester. This tester did not function on the chip and direct bit error rate measurements could not be done. However, the output of the receivers is connected to a modulator, and received data could be verified by optically reading the state of the modulators.

The optical setup for the link is shown in figure 8. Spindler and Hoyer components were used to assemble the setup. There were a few problems with the design of the setup:

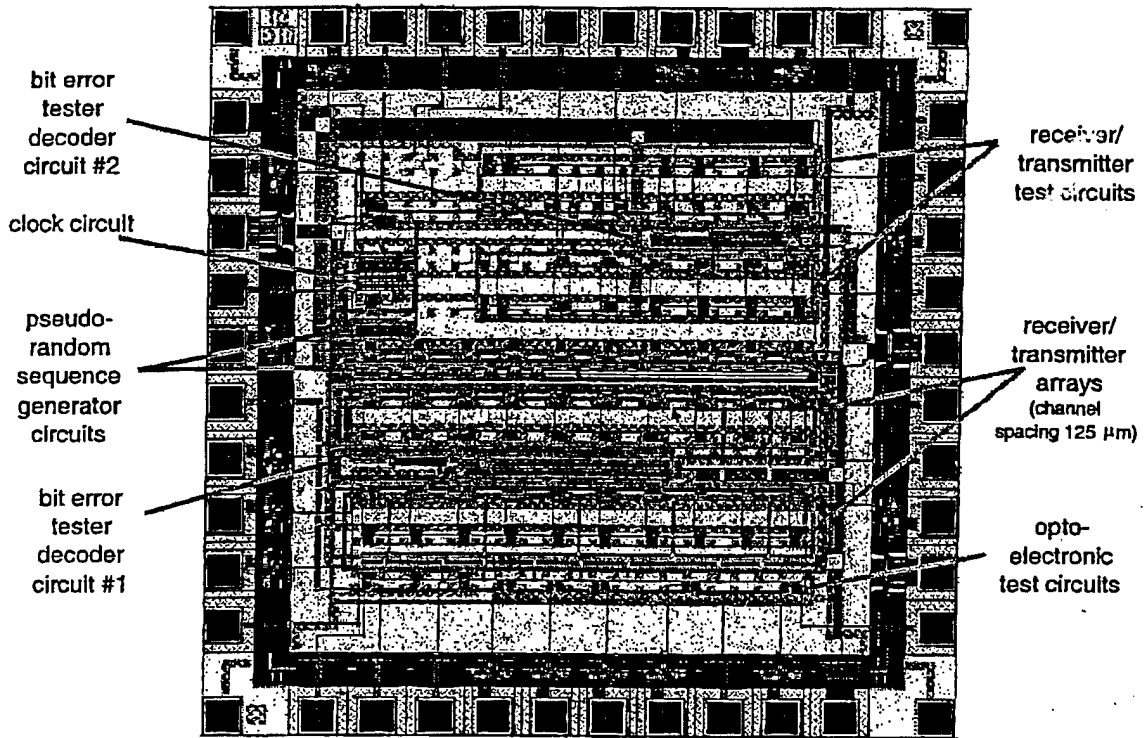

Figure 7. Layout of the first generation silicon chip

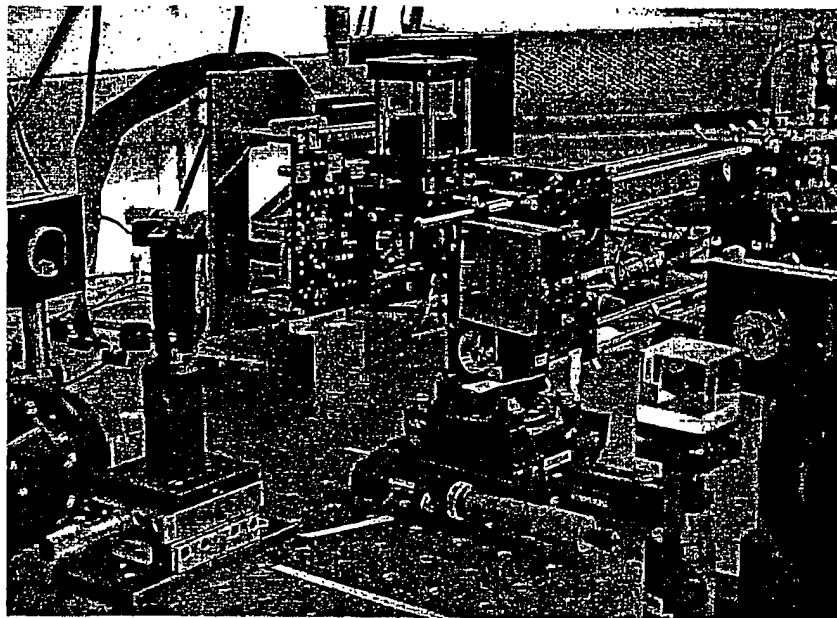

Figure 8. Optical setup of the first generation WDM link

1. Components were mounted at a height on thin rod structures and they were susceptible to mechanical vibrations.
2. Any vibration causing angular variation in the grating was magnified causing the spot to move off the optical components.
3. Losses in the system were too high to make the entire link work with the fiber link.

### **Second Generation WDM**

The optical setup for the second generation link was designed with stability and the reduction of losses as the main criteria. The entire design was done with baseplates. The grating used in this setup is a gold-coated echelle grating, with 1200 lines/mm. This grating is used in littrow configuration.

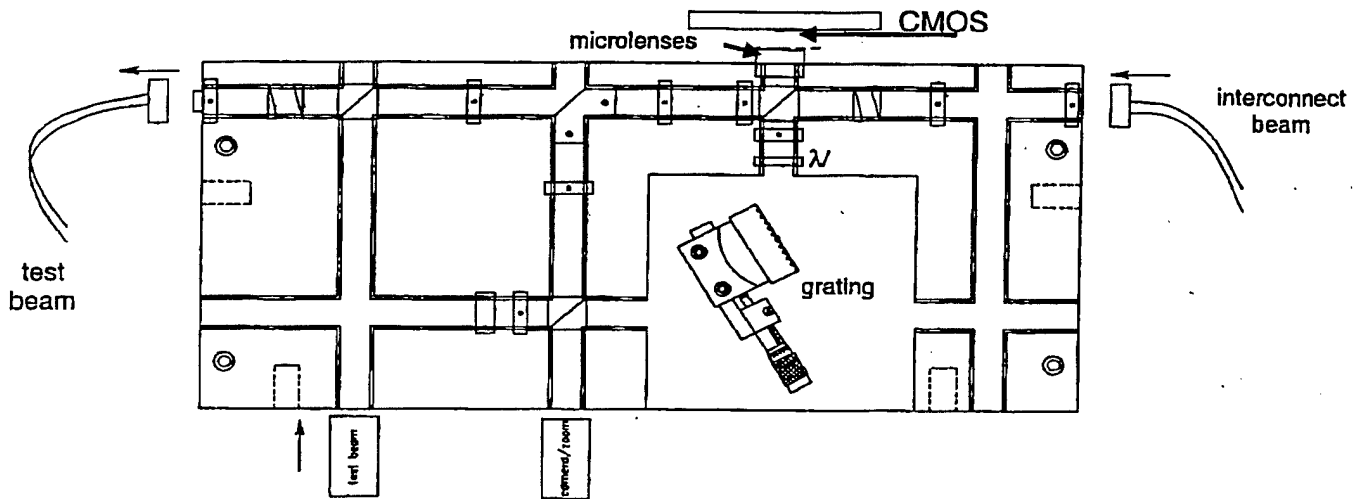

Figure 9. Schematic of the receiver side of the second generation optical setup using baseplates

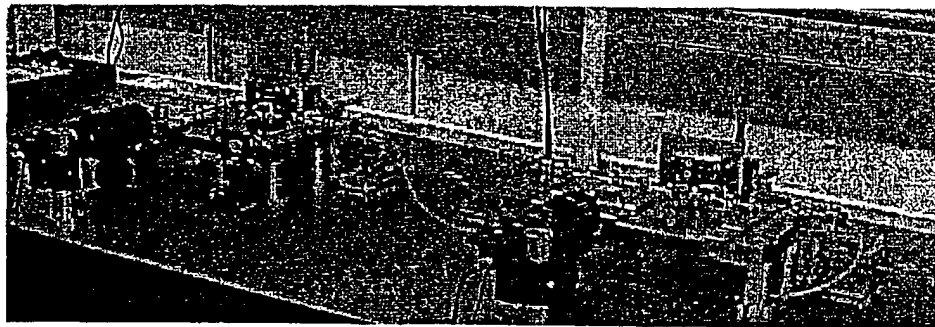

Figure 10. Picture of the second generation optical setup

The silicon CMOS (complementary metal oxide semiconductor) chip for this setup was

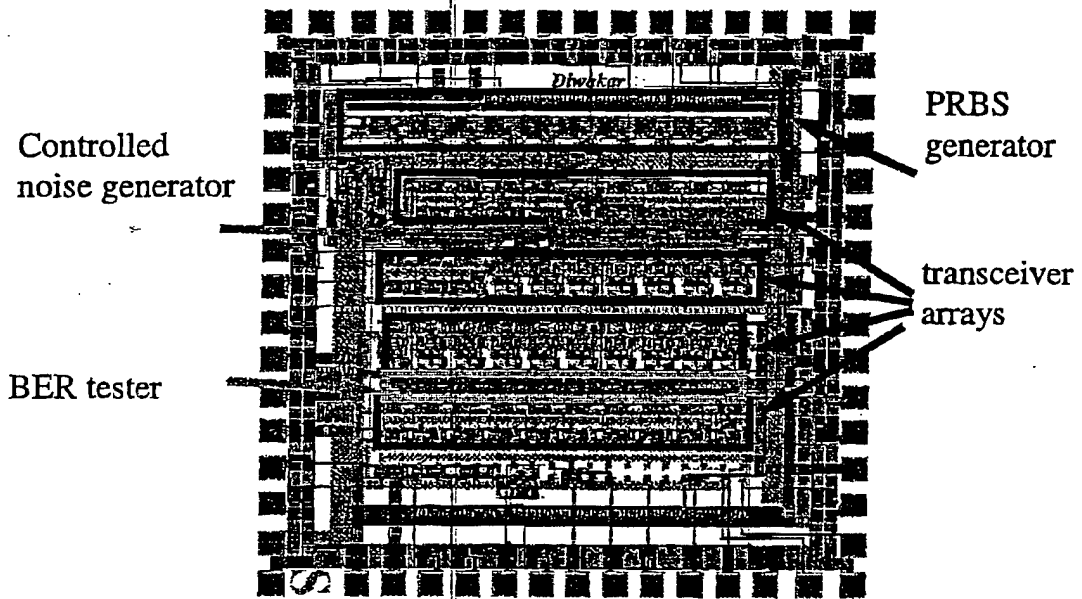

Figure 11. Layout of the second generation silicon chip

designed to rectify errors in the earlier chip and to incorporate more functionality. This chip was also fabricated in  $0.5\mu\text{m}$  CMOS technology through MOSIS. Like the earlier chip, this chip also has a pseudo random bit sequence (PRBS) generator driving an array of modulators. There are two arrays of receivers to be operated with the array of modulators (figure.12 shows the schematic of these receivers).

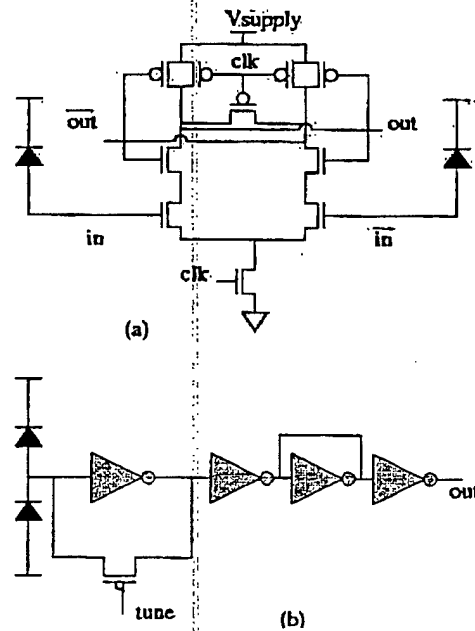

Figure 12. Schematic of (a) sense-amp receiver (b) transimpedance receiver

One array consists of transimpedance receivers and the other array consists of sense amplifier receivers. There are noise generators on this chip to evaluate the receiver performance penalty with the injection of substrate noise.

Both the optical device fabrication and hybrid integration were done at Stanford, using an approach similar to the earlier work done by Lucent Technologies.

## VI. Demonstrations and Results

The first generation receivers were tested for their performance. The operation of the transimpedance receiver at 700Mb/s is shown in figure 13. The input data was a random sequence modulated in non-return to zero (NRZ) format. Random data modulated with short pulses generated the eye diagram shown in figure 14. Since the repetition rate of the short pulse laser is 82 MHz, receivers were limited in operation to that speed. Although, as evident from NRZ operation, the receivers are capable of operating at 700Mbps.

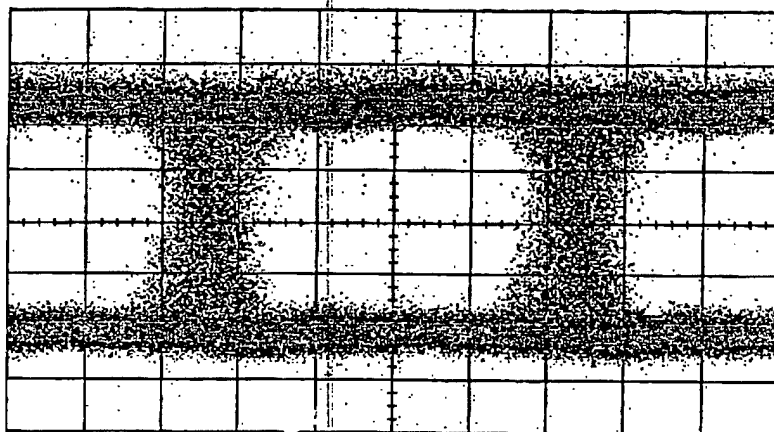

Figure 13. Eye diagram from a receiver circuit operating at 700 Mb/s, measured by optically reading out a modulator driven by the receiver circuit output. Data is from a pair of modulated CW lasers.

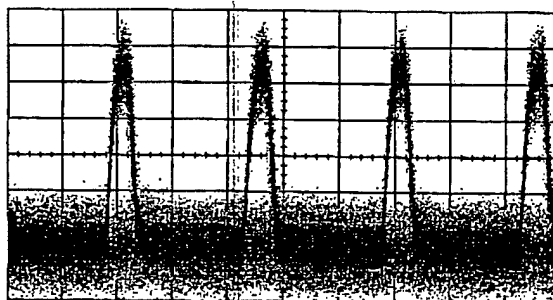

Figure 14. Eye diagram from a receiver circuit operating at 82 Mb/s, measured by optically reading out a modulator driven by the receiver circuit output. Data is from a short pulse laser.

### Skew and jitter removal

Reading out the state of the modulators with short optical pulses can remove up to half a bit period of skew or jitter. This concept is illustrated in figure 15. As shown in figure 16, with the introduction of up to  $\pm 3/8$  bit of jitter on the electrical input of a modulator channel, we see that the jitter is transferred to the receiver when using a cw laser-based interconnect. However, when we use a short optical pulse (temporally centered in the electrical bit), all the jitter is removed. In both cases, a cw laser is used to read the channel state at the receiver chip. The receiver output circuitry is neither clocked nor latched, so the receiver output can be seen to relax to the off state with a characteristic time constant.

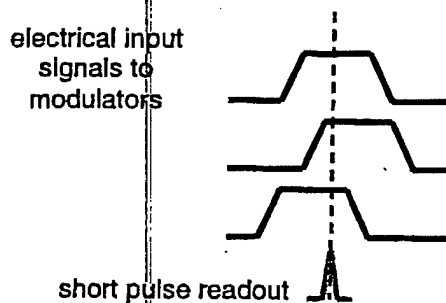

Figure 15. Conceptual illustration of modulator skew and jitter removal using short pulses with a modulator-based interconnect.

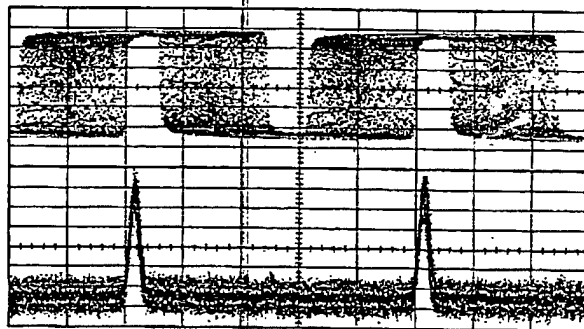

Figure 16. Demonstration of jitter removal from a single interconnect channel, at a clock rate of 82 MHz. Upper trace is the electrical input signal; lower trace is the receiver circuit optical readout

Electrical data signals can be simultaneously applied to multiple transmitter channels in the array. Figure 17 shows the modulator outputs from two of these channels, which are skewed by  $3/8$  of a bit relative to one another. We monitor one reflected beam from each differential pair, first for the cw and then the short pulse interconnect. While the inter-channel skew remains for the cw-based interconnect, the short pulses effectively remove all skew.

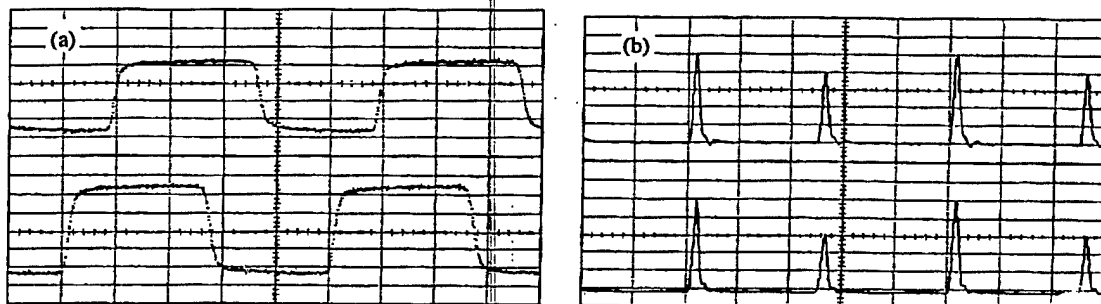

Figure 17. Transmitted signals from two channels operating at 82 MHz, whose electrical inputs are skewed by 3/8 of a bit. Readout is performed with (a) a cw laser, and (b) a short pulse laser. Skew is removed by the use of the short optical pulses.

### Operation of the first generation WDM system

The operation of a section of the transmitter array is shown in figure 18.

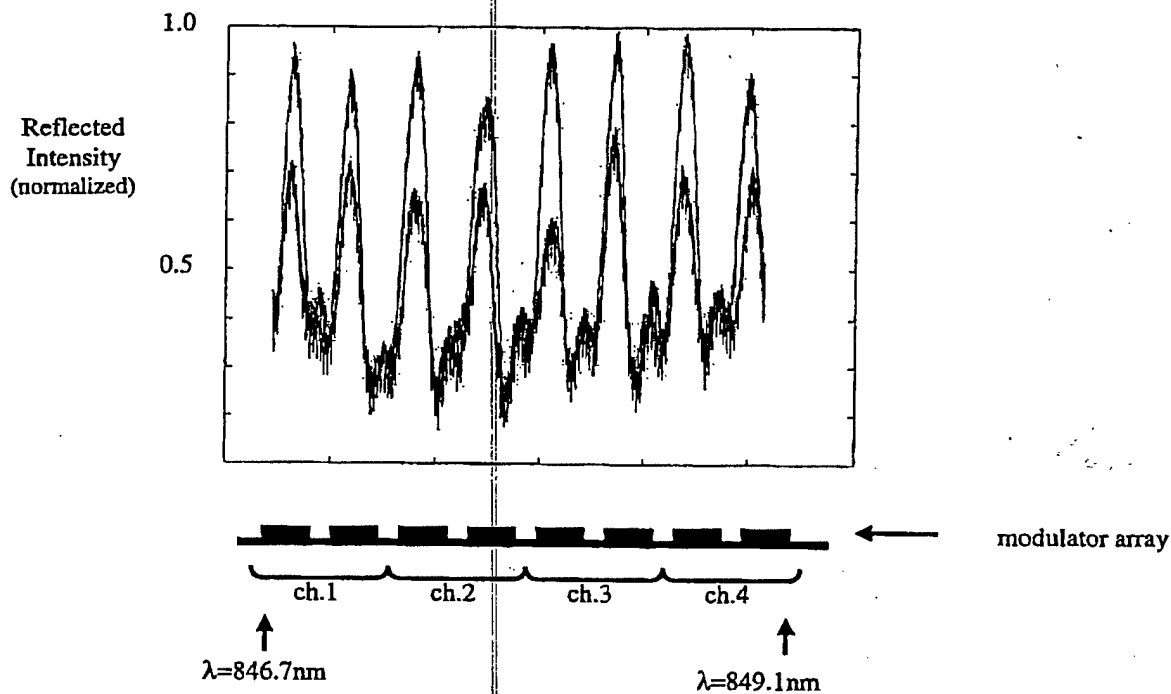

Figure 18. Measured reflected signal from the transmitter array at two different instances, represented by red and blue.

First generation WDM system had high losses and the link could not be operated with the fiber. Using free space medium, the link was operated at 20 Mbps, and the performance is shown in figure 19.

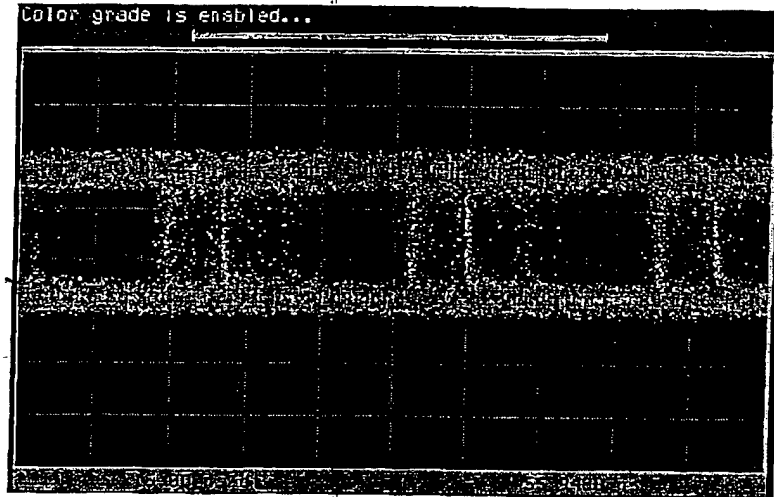

Figure 19. Receiver eye with optical readout while running the entire WDM system at 20MHz

### ***Second generation WDM link***

The optical setup for the second generation link is ready and the chip testing is currently in progress. The new system is more stable and is designed for lower losses. It is expected that the complete system will be demonstrated soon. The functionality of the silicon chip is verified and most of the digital circuits are performing as expected.

### **VII. Conclusions**

The first generation wavelength division multiplexed optical link was demonstrated. The optoelectronic devices for the first generation chips were fabricated by Lucent Technologies. Due to the high losses, the system demonstration was limited to 20 Mbps. The skew and jitter removal was demonstrated with short optical pulses using chip to chip optical link on slotted stainless steel baseplates. The receivers were operated up to 700 Mbps. The second generation optical setup is designed for lower losses and more stability. The functionality of digital circuits on the second generation silicon chip is verified. The optoelectronic device fabrication and the hybrid integration to the second generation silicon chip are done at Stanford.

### **VIII. Publications**

1. Diwakar Agarwal, Gordon A. Keeler, Bianca E. Nelson, and David A. B. Miller, "Wavelength Division Multiplexed Optical Interconnects Using Femtosecond Optical Pulses," Presented at the Lasers and Electro-Optics Society Twelfth Annual Meeting, San Francisco, CA (November 8-11, 1999). Paper ThT4.
2. Gordon A. Keeler, Bianca E. Nelson, Diwakar Agarwal, and David A. B. Miller, "Optical Interconnects Using Short Optical Pulses," Presented at the Lasers and Electro-Optics Society Twelfth Annual Meeting, San Francisco, CA (November 8-11, 1999). Paper ThT5.
3. Gordon A. Keeler, Bianca E. Nelson, Diwakar Agarwal, and David A. B. Miller, "Skew and jitter removal using short optical pulses for optical interconnection," IEEE Photonics Technol. Lett. , 12, 714 -716 (2000)