

DISTRIBUTION STATEMENT A
Approved for Public Release
Distribution Unlimited

**FINAL REPORT
FOR THE
CONCEPT DEVELOPMENT
OF THE
LOGISTICS VEHICLE SYSTEM
REPLACEMENT**

REPORT NO: R37746-00003A

DATE December 1997

**SUBMITTED BY
AAI CORPORATION
A subsidiary of United Industrial Corporation
P.O. Box 126 - Hunt Valley, MD 21030-0126**

FOR

**NAVAL SURFACE WARFARE CENTER
Carderock Division
Bethesda, Maryland 2084-5000**

PREPARED BY



S. W. Miller

CONTRACT NO. N00167-96-C-0048

SEQUENCE NO. A004

APPROVED BY

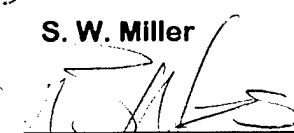

M. B. Hodges

DATA ITEM DI-MISC-80711

20020503 076

REPORT DOCUMENTATION PAGE

Form Approved
OMB No. 0704-0188

Public reporting burden for this collection of information is estimated to average 1 hour per response, including the time for reviewing instructions, searching existing data sources, gathering and maintaining the data needed, and completing and reviewing this collection of information. Send comments regarding this burden estimate or any other aspect of this collection of information, including suggestions for reducing this burden to Department of Defense, Washington Headquarters Services, Directorate for Information Operations and Reports (0704-0188), 1215 Jefferson Davis Highway, Suite 1204, Arlington, VA 22202-4302. Respondents should be aware that notwithstanding any other provision of law, no person shall be subject to any penalty for failing to comply with a collection of information if it does not display a currently valid OMB control number. **PLEASE DO NOT RETURN YOUR FORM TO THE ABOVE ADDRESS.**

1. REPORT DATE (DD-MM-YYYY) 30-12-1997		2. REPORT TYPE Concept Analysis		3. DATES COVERED (From - To) Dec. 96- Dec 1997		
4. TITLE AND SUBTITLE Final Report for the Concept Development of the Logistic Vehicle System Replacement (LVSR)				5a. CONTRACT NUMBER		
				5b. GRANT NUMBER		
				5c. PROGRAM ELEMENT NUMBER		
6. AUTHOR(S) Stephen W. Miller, Steven J. Fox, Richard Dryer, David Felid, Chris Baumeister, Bob Neugebauer, Mark Mayo				5d. PROJECT NUMBER		
				5e. TASK NUMBER		
				5f. WORK UNIT NUMBER		
7. PERFORMING ORGANIZATION NAME(S) AND ADDRESS(ES) Jacobs Sverdrup Technology, Inc. 25 Clement Drive, Suite 101 Stafford, Virginia 22554				8. PERFORMING ORGANIZATION REPORT NUMBER		
9. SPONSORING / MONITORING AGENCY NAME(S) AND ADDRESS(ES) Marine Corps Systems Command 2033 Barnett Ave Suite 315 Quantico, Virginia 22134-5010				10. SPONSOR/MONITOR'S ACRONYM(S) MARCORSYSCOM		
				11. SPONSOR/MONITOR'S REPORT NUMBER(S)		
12. DISTRIBUTION / AVAILABILITY STATEMENT Distribution Statement A						
13. SUPPLEMENTARY NOTES None						
14. ABSTRACT This report documents a 12 month effort to explore four areas of mobility enhancement for the LVSR: 1) Payload enhancement; 2) Power plant upgrade; 3) Suspension upgrade; and 4) Terrain adaptive technologies. Included in the report are alternative vehicle concepts, performance analyses, VEHDYN2 ride quality analysis, 3-D dynamic analyses, and a recommended LVSR configuration.						
15. Subject Terms LVSR, NRMM, ride quality analysis, mobility analysis, power upgrade, suspension upgrade, and VEHDYN2.						
16. SECURITY CLASSIFICATION OF: Unclassified			17. LIMITATION OF ABSTRACT SAR	18. NUMBER OF PAGES 132	19a. NAME OF RESPONSIBLE PERSON Timothy L. McMahand	
a. REPORT	b. ABSTRACT Unclassified	c. THIS PAGE			19b. TELEPHONE NUMBER (include area code) (540) 657-8000 ext#113	

AQM02-08-1417

REPORT DOCUMENTATION PAGE	1. REPORT NO. A004	2.	3. Recipient's Accession No.
4. Title and Subtitle Final Report for the Concept Development of the Logistics Vehicle System Replacement		5. Report Date September 1997	
7. Author(s) Stephen W. Miller, Steven J. Fox, Richard Dryer, David Feild, Chris Baumeister, Bob Neugebauer, Mark Mayo		8. Performing Organization Rept. No. R37746-00003A	
9. Performing Organization Name and Address AAI Corporation P.O. Box 126 Hunt Valley, MD 21030-0126		10. Project/Task/Work Unit No.	
12. Sponsoring Organization Name and Address Marine Corps Vehicle & Expeditionary Systems Dept., Code 2800 Naval Surface Warfare Center Carderock Division Bethesda, MD 20084-5700		11. Contract(C) or Grant(G) No. (C)N00167-96-C-0048	
15. Supplementary Notes Contracting Officers Technical Representative (COTR) - Steven Ouimette (301)227-4219		13. Type of Report & Period Covered Contractor Report	
16. Abstract (Limit: 200 words) This report documents a 12 month effort to explore four areas of mobility enhancement for the LVSR: 1) Payload enhancement; 2) Power plant upgrade; 3) Suspension upgrade; and 4) Terrain adaptive technologies. Included in the report are alternative vehicle concepts, performance analyses, VEHDYN2 ride quality analysis, 3-D dynamic analyses, and a recommended LVSR configuration.		14. Dec. 96 - Dec. 97	
17. Document Analysis a. Descriptors			
b. Identifiers/Open-Ended Terms Logistics Vehicle Systems (LVS), Logistics Vehicle System Replacement (LVSR), United States Marine Corps (USMC), Motor Transport, heavy lift, payload upgrade, power upgrade, suspension upgrade, ride quality analysis, mobility analysis, NRMM, and VEHDYN2.			
c. COSATI Field/Group			
18. Availability Statement Distribution Limited: Further dissemination only as directed by the Commanding Officer NSWC, Code 2020, Bethesda, MD 20084-5000		19. Security Class (This Report) Unclassified	21. No. of Pages
		20. Security Class (This Page) Unclassified	22. Price

TABLE OF CONTENTS

<u>SECTION</u>	<u>PAGE NO.</u>
1. Summary.....	1-1
2. Systems Engineering Approach.....	2-1
3. Needs Analysis.....	3-1
3.1 User Survey.....	3-1
3.2 Duty Cycle.....	3-3
3.3 Specification Requirements Review.....	3-4
3.4 Mission Needs Statement.....	3-8
3.5 Highway Transportability Restriction.....	3-9
3.6 Federal Motor Vehicle Safety Standards.....	3-11
3.7 EPA certification.....	3-11
3.8 Desired Enhancements.....	3-13
4. Concept Exploration.....	4-1
4.1 Payload Enhancement.....	4-7
4.1.1 Candidate Suspension Configurations.....	4-13
4.1.2 Trafficability.....	4-17
4.1.3 Ride Performance.....	4-20
4.2 Power Plant Upgrade.....	4-28
4.2.1 Engines.....	4-30
4.2.1.1 Engine Specifications.....	4-30
4.2.1.2 Candidate Engines.....	4-33
4.2.2 Transmissions.....	4-34
4.2.2.1 Candidate Transmission.....	4-34
4.2.3 Performance.....	4-35
4.2.3.1 Gradability.....	4-36
4.2.3.2 Acceleration.....	4-41
4.2.3.3 Fuel Economy.....	4-43

<u>SECTION</u>	<u>PAGE NO.</u>
4.2.4 Installations.....	4-44
4.3 Suspension Upgrade.....	4-47
4.3.1 Candidate Suspension Configurations.....	4-47
4.3.2 Trafficability.....	4-58
4.3.3 Ride Performance.....	4-61
4.3.4 Side Slope Performance.....	4-68
4.4 Terrain Adaptive Technology.....	4-70
4.4.1 Drivetrain.....	4-71
4.4.2 Central Tire Inflation.....	4-73
4.4.3 Anti-Lock Braking Systems.....	4-73
5. Recommended Concept Definition.....	5-1
5.1 System Description.....	5-1
5.1.1 Power Plant.....	5-3
5.1.2 Suspension.....	5-3
5.1.3 Terrain Adaptive Systems.....	5-4
5.1.4 Steering System.....	5-4
5.2 Dynamic Analysis.....	5-5
5.2.1 Turning Circle.....	5-10
5.2.2 Side Slope Operation.....	5-12
5.2.3 Tilt Table Test.....	5-14
5.2.4 Lateral Acceleration.....	5-17
5.2.5 Lane Change Maneuver.....	5-18
5.3 Mobility.....	5-21
5.3.1 Trafficability.....	5-21
5.3.2 Ride Quality.....	5-22

LIST OF FIGURES

<u>TITLE</u>	<u>PAGE NO.</u>
2.0-1 Concept development Phase.....	2-1
4.0-1a Preliminary LVSR Concepts.....	4-3
4.0-1b Preliminary LVSR Concepts.....	4-4
4.0-1c Preliminary LVSR Concepts.....	4-5
4.1-1 Functional LVS Block Diagram.....	4-7
4.1-2 Baseline LVS Front Power Unit equipment arrangement.....	4-8
4.1-3 Baseline LVS Rear Body Unit equipment arrangement.....	4-9
4.1.1-1 Reuse 10X10 RBU with Meritor ISAS.....	4-14
4.1.1-2 Resuse 10X10 with NEWAY Air Ride	4-15
4.1.2-1 Sample VCI Worksheet.....	4-18
4.1.2-2 Vehicle Trafficability Comparison.....	4-19
4.1.2-3 Vehicle Trafficability Improvement.....	4-19
4.1.3-1 FPU Spring Characteristics.....	4-20
4.1.3-2 RBU Spring Characteristics.....	4-21
4.1.3-3 FPU Shock Absorber Characteristics.....	4-21
4.1.3-4 MK48/14 Vehicle Geometry.....	4-22
4.1.3-5 VEHDYN2 Analyses Results.....	4-23
4.1.3-6a Ride Quality Comparison (Rated Payload).....	4-25
4.1.3-6b Ride Quality Comparison (Empty).....	4-25
4.1.3-7a Ride Quality Improvement (Rated Payload).....	4-26
4.1.3-7b Ride Quality Improvement (Empty).....	4-26
4.1.3-8 VEHDYN2 Input File.....	4-27
4.2-1 Existing Front Power Unit.....	4-28
4.2-2 Grade vs Speed 66,000 LB.....	4-37
4.2-3 Grade vs Speed 77,400 LB.....	4-37
4.2-4 Grade vs Speed 86,000 LB.....	4-38

LIST OF FIGURES, continued

<u>TITLE</u>	<u>PAGE NO.</u>
4.2-5 Grade vs Speed 140,600 LB.....	4-38
4.2-6 Grade vs Speed 445 HP.....	4-39
4.2-7 Grade vs Speed 500 HP.....	4-39
4.2-8 Grade vs Speed 600 HP.....	4-40
4.2-9 Time to Speed 77,400 LB.....	4-41
4.2-10 Time to Speed 86,000 LB.....	4-42
4.2-11 Time to Speed 140,600 LB.....	4-42
4.2-12 Fuel Economy Comparison.....	4-44
4.2-13 Caterpillar C12 and Allison 4070P.....	4-45
4.2-14 Caterpillar C12 and Eaton CEEMAT.....	4-45
4.2-15 Perkins CV6 and CEEMAT.....	4-46
4.3.1-1 FPU with Meritor ISAS.....	4-55
4.3.1-2 RBU with Meritor ISAS.....	4-55
4.3.1-3 FPU with NEWAY AD-246 Suspension.....	4-56
4.3.1-4 RBU with NEWAY AD-252 Suspension.....	4-57
4.3.2-1a Vehicle Trafficability.....	4-60
4.3.2-1b Vehicle Trafficability Improvement.....	4-60
4.3.2-2a Hybrid Vehicle Trafficability.....	4-61
4.3.2-2b Hybrid Vehicle Trafficability Improvement.....	4-61
4.3.3-1a Ride Quality Comparison (Rated Payload).....	4-63
4.3.3-1b Ride Quality Comparison (Empty).....	4-63
4.3.3-2a Ride Quality Comparison (Rated Payload).....	4-64
4.3.3-2b Ride Quality Comparison (Empty).....	4-64
4.3.3-3a Ride Quality Comparison (Rated Payload).....	4-65
4.3.3-3b Ride Quality Comparison (Empty).....	4-65

LIST OF FIGURES, continued

<u>TITLE</u>	<u>PAGE NO.</u>
4.3.3-4a Ride Quality Comparison (Rated Payload).....	4-66
4.3.3-4b Ride Quality Comparison (Empty).....	4-66
4.3.4-1 Rollover Model.....	4-69
5.1-1 LVSR Functional Block Diagram.....	5-2
5.2-1 Basic ADAMS Model Structure.....	5-6
5.2-2 Model with Recommended LVSR Suspension.....	5-9
5.2-3 Meritor (Rockwell) Suspension Components.....	5-9
5.2-4 NEWAY Typical Suspension Components, Showing Staggered Transverse Torque Rod Arrangement.....	5-10
5.2-5 Fitted Meritor (Rockwell) Suspension Data.....	5-10
5.2.2-1 Side Slope with Obstacle Avoidance.....	5-12
5.2.2-2 LVS with 45k Payload on 30% Side Slope.....	5-13
5.2.2-3 Recommended Vehicle with 45k Payload on 30% slope.....	5-14
5.2.3-1 Curve Fit of Michelin Data for Tilt Table Tire Spring.....	5-15
5.2.3-1 30% Tilt Table Comparison: 45k Payload for LVS (left) Recommended Vehicle (right).....	5-16
5.2.4-1 LVS with 25k Payload at 25 mph on 75-foot Circle.....	5-17
5.2.5-1 Lane Change Course.....	5-18
5.2.5-2 Lateral Acceleration vs Time for LVS, 25k payload at 15 mph, 102 psi Tires.....	5-20
5.2.5-3 Tire Vertical Load vs Time for LVS, 25k Payload at 20 mph, 40 psi Tires.....	5-20
5.3.1-1 Trafficability Performance.....	5-21
5.3.1-2 Predicted Trafficability Improvement.....	5-22
5.3.2-1 Meritor (Rockwell) Suspension Spring Characteristics.....	5-23
5.3.2-2 NEWAY Suspension Spring Characteristics.....	5-23

LIST OF FIGURES, continued

LIST OF FIGURES, continued

<u>TITLE</u>	<u>PAGE NO.</u>
5.3.2-3 Meritor (Rockwell) Suspension Damper Characteristics.....	5-24
5.3.2-4 NEWAY Suspension Damper Characteristics.....	5-24
5.3.2-5 Recommended LVSR Concept Geometry.....	5-26
5.3.2-6a Ride Quality Comparison (Rated Payload).....	5-27
5.3.2-6b Ride Quality Comparison (Empty).....	5-28
5.3.2-7a Ride Quality Improvement (Rated Payload).....	5-28
5.3.2-7b Ride Quality Improvement (Empty).....	5-29
5.3.2-8 VEHDYN2 Input File	5-30

LIST OF TABLES

<u>TITLE</u>	<u>PAGE NO.</u>
3.3-1 Vehicle Specifications	3-6
3.3-2 Vehicle Mobility Specifications.....	3-7
4.0-1 Preliminary Concept comparison.....	4-6
4.1-1 Tabulation of Axle Weights and CGs for the LVS Family.....	4-11
4.1-2 Baseline LVS mass properties and axle loading.....	4-12
4.1.1-1 Reuse 10X10 mass properties and axle loading.....	4-16
4.1.2-1 Baseline Vehicle Axle Loads.....	4-17
4.1.2-2 Reuse 10X10 Axle Loads.....	4-17
4.1.2-3 Baseline Vehicle Trafficability.....	4-19
4.1.2-4 Reuse 10X10 Vehicle Trafficability.....	4-19
4.1.3-1 WES Ride Quality Data for LVS Baseline.....	4-20
4.1.3-2 Michelin Tire Data.....	4-22
4.1.3-3 Baseline Limit Speed Results.....	4-23
4.1.3-4 Predicted Performance for the Reuse 10X10.....	4-24
4.2-1 Weight and horsepower comparison.....	4-29
4.2-2 Engine Specifications.....	4-32
4.2-3 Transmission Comparison.....	4-35
4.2-4 LVS Percent Grade and Speed Requirements (MPH).....	4-36
4.3.1-1 Meritor 10X10 mass properties and axle loading.....	4-49
4.3.1-2 NEWAY 10X10 mass properties and axle loading.....	4-50
4.3.1-3 Hybrid A mass properties and axle loading.....	4-51
4.3.1-4 Hybrid B mass properties and axle loading.....	4-52
4.3.1-5 Hybrid C mass properties and axle loading.....	4-53
4.3.2-1a Meritor Independent Suspension.....	4-58
4.3.2-1b NEWAY Air-Ride Suspension.....	4-58
4.3.2-1c Hybrid A.....	4-58
4.3.2-1d Hybrid B.....	4-59
4.3.2-1e Hybrid C.....	4-59
4.3.3-1 Ride Performance Predictions.....	4-62

LIST OF TABLES, continued

<u>TITLE</u>	<u>PAGE NO.</u>
4.3.3-2a Ride Performance Predictions.....	4-62
4.3.3-2b Ride Performance Predictions.....	4-62
4.3.4-1 Static Rollover Results at 12.5 Ton Payload.....	4-68
4.3.4-2 Static Rollover Results at 22.5 Ton Payload.....	4-68
4.3.4-3 RBU Roll Model Parameters.....	4-70
4.3.4-4 RBU Suspension Roll Results.....	4-70
5.3.1-1 Recommended LVSR Concept Vehicle Trafficability Performance.	5-21
5.3.2-1 Michelin Tire Characteristics.....	5-25
5.3.2-2 Predicted Performance.....	5-26

LIST OF SYMBOLS AND ABBREVIATIONS

<u>SYMBOL</u>	<u>NAME</u>
AAAV	Advanced Amphibious Assault Vehicle
ABS	Anti-lock Braking System
ADAMS	Automatic Dynamic Analysis of Mechanical Systems
APG	Aberdeen Proving Ground
ARB	Air Research Board
ATC	Aberdeen Test Center
BSA	Beach Support Area
C-C	Cross Country
CG	Center of Gravity
CSSA	Combat Service Support Area
CTI	Central tire inflation
EPA	Environmental Protection Agency
FMVSS	Federal Motor Vehicle Safety Standards
FPU	Front Power Unit
GCVW	Gross Combined Vehicle Weight
GVW	Gross Vehicle Weight
HEMTT	Heavy Expanded Mobility Tactical Truck
HMMWV	High Mobility Multi-purpose Wheeled Vehicle
IPT	Initial Production Tests
ISAS	Independent Suspension Axle System
LVS	Logistic Vehicle System
LVSR	Logistic Vehicle System Replacement
MAPC	Maritime Applied Physics Corporation
MNS	Mission Need Statement
M/S/S	Mud/Sand/Snow
MTVR	Medium Tactical Vehicle Replacement
NATO	North Atlantic Treaty Organization
NRMM	NATO Reference Mobility Model
PLS	Palletized Load System
RBU	Rear Body Unit
ROC	Required Operational Capability
RPM	Revolutions Per Minute
SAE	Society Of Automotive Engineers
TVF	Tactical Vehicle Fleet
USMC	United States Marine Corps
VEHDYN2	Vehicle ride and dynamics module of the NRMM
VCI	Vehicle Cone Index

1. Summary

The Logistic Vehicle System (LVS) was originally fielded from 1985 through 1989 to fulfill Marine Corps heavy tactical lift requirements. The heavy lift requirement includes the bulk transport of fuel, water, ammunition and other supplies. The LVS was specifically equipped to haul dimensionally standardized cargo containers. Most of the current LVS fleet will reach the end-of service-life in 2005 at which time the cost to keep them operational is expected to increase dramatically. The goal of the Logistic Vehicle System Replacement (LVSR) program is to field a cost effective replacement for the LVS with enhanced capabilities.

During this Concept Development Stage of the LVSR program AAI Corporation was tasked to concentrate on upgrades that can be adapted to the existing LVS. These LVSR studies have been restricted to upgrades that enhance mobility and payload capacity. Upgrading, rather than completely replacing the LVS, is expected to be the most cost effective alternative for the Marine Corps. Frame Life Studies conducted by the Aberdeen Test Center (ATC) indicate that the existing LVS frame structure has sufficient capacity to serve the Marines beyond the year 2005. Alternative vehicles as well as development of an "all new" LVS is the subject of future studies that will be considered by a Defense Acquisition Board prior to approving the Demonstration and Validation Phase of the LVSR program.

AAI followed a systems engineering approach during this Concept Development Stage which includes; needs analysis, concept exploration, and concept definition. This approach began with the analysis of the needs or requirements. These investigations included; a user survey, evaluations of current US military vehicles, the Mission Need Statement for the LVSR, applicable roadway laws and regulations and emerging Marine Corps requirements. As a result of the needs analysis four areas of mobility enhancement were identified for Concept Exploration:

- 1) Payload enhancement
Increase off-road payload to 35,000 lbs minimum (45,000 lbs desired)
- 2) Power Plant Upgrade
Increase power plant capacity to achieve improved performance with improved fuel economy and reduced exhaust emissions
- 3) Suspension Upgrade
Increase ride quality and stability of the existing system
- 4) Terrain Adaptive Technology
Improve mobility and safety by applying new automotive technologies

In the area of payload enhancement AAI examined the benefits and complexities of adding one axle to the existing LVS suspension. In the area of power plant upgrade AAI explored the engine and transmission options available to increase the installed horsepower from the current 445 horsepower up to 600 horsepower. Performance comparisons for various engine and transmission combinations have been analyzed. Suspension upgrade investigations have been extensive. These investigations include;

- 1) The development of five (5) alternative suspension arrangements
- 2) Trafficability analysis
- 3) Ride performance modeling using VEHDYN2
- 4) Stability analysis

In the area of terrain adaptive technologies, drivetrain management, traction control, anti-lock braking systems and central tire inflation systems have been analyzed for possible application on the LVSR.

Based on the Concept Exploration findings, a Recommended LVSR configuration was defined. This recommended configuration included:

- 1) 10X10 suspension configuration
- 2) A diesel engine with similar size and performance characteristics to the Perkins CV6 diesel engine rated at 600 hp
- 3) A transmission with similar size and performance characteristics to the Allison HD 4070 transmission
- 4) A suspension system with similar size and performance characteristics to the Meritor (Rockwell) independent suspension for the front power unit
- 5) A suspension system with similar size and performance characteristics to the NEWAY air suspension for rear power unit
- 6) Central tire inflation, Anti-lock brakes, Traction Control

In addition to the trafficability and ride performance predictions generated during the Concept Exploration a detailed 3-D Dynamic analysis of the Existing LVS and Recommended LVSR Concept was conducted using ADAMS software.

Virtual dynamic testing that was conducted includes:

- 1) Turning circle (Shortest turning diameter)
- 2) 30% side slope operation
- 3) Tilt table testing
- 4) Lateral acceleration
- 5) Lane change maneuver

In all tests, the Recommended LVSR with a 17.5 ton payload met or exceeded the performance of the Baseline LVS with a 12.5 ton payload.

2. Systems Engineering Approach

The systems engineering approach used for the Concept Development Phase of the LVSR follows the method presented in "System Engineering Principles and Practices, a guide to engineering of complex systems", written by Kossiakof and Sweet of the Johns Hopkins Applied Physics Lab. The principle objectives of the Concept Development Phase are to:

- 1) Establish the needs or requirements
- 2) Explore potential system concepts and formulate and validate a set of system performance characteristics.
- 3) Select the most attractive system concept, define its characteristics and develop a detailed plan for engineering development.

As shown in **Figure 2.0-1** the Concept Development phase consists of three parts, referred to as Needs Analysis, Concept Exploration and Concept Definition.

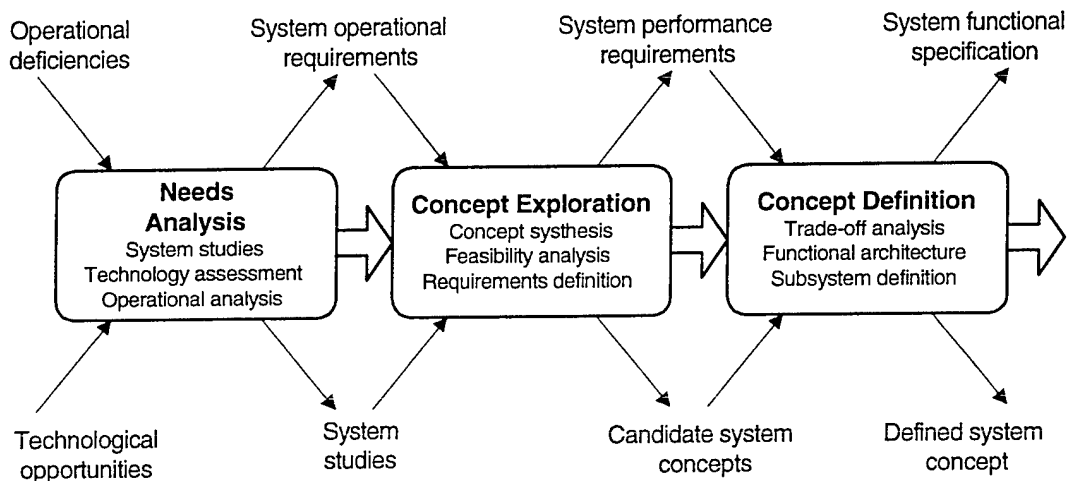

Figure 2.0-1 Concept Development Phase

Needs Analysis defines the need. It addresses the questions: Is there a valid need for an upgraded LVSR, and is there a practical approach to satisfy such a need? These questions require a critical examination of the degree to which current and perceived future needs cannot be satisfied by physical or operational modification of available means, as well as whether or not technology is likely to support the increased capability desired.

Concept Exploration examines potential system concepts in answering the questions: What performance is required of the new system to meet the perceived need, and is there at least one feasible approach to achieving such performance at an affordable cost? Positive answers to these questions set valid and achievable goals for a new system project prior to expending a major effort on its development.

Concept Definition selects the preferred concept. It answers the question: What are the key characteristics of a system concept that would achieve the most beneficial balance between capability, operational life and cost? To answer this question a number of alternative concepts must be considered and their relative performance, operational utility, development risk and cost must be compared.¹

¹ Kossiakof and Sweet, "System Engineering Principles and Practices, a guide to engineering of complex systems", Johns Hopkins University (1997)

3. Needs Analysis

The requirements for the LVSR are based on several factors including; inputs from LVS users, the current military logistic vehicles, the Mission Need Statement, applicable laws and regulations, and the emerging future Marine Corps requirements. These factors are described and analyzed below.

3.1 User Survey

An LVS user survey was conducted during 1997 by the Maritime Applied Physics Corporation (MAPC) in Laurel Maryland to gain feedback from Marines who are involved with the maintenance and operation of the LVS. A summary of the detailed User Survey Report, which has been provided by MAPC to the Marine Corps Vehicle & Expeditionary Systems Department at the Naval Surface Warfare Center, Carderock Division, is provided below. Many of the findings of the survey are in areas related to mobility and payload capacity.

The Marines participated in the survey with enthusiasm and the majority were thorough in their evaluations. The Marines generally felt that the LVS is a capable vehicle that adequately met mission needs. The survey included 239 Marines stationed at a variety of locations including; 1) Camp Lejeune, NC, 2) Camp Pendleton, CA, 3) Camp Johnson, NC and 4) Baltimore, MD. Operators, Maintainers and Supervisors were surveyed using Questionnaires that were tailored for their job responsibilities.

Responses to the survey were evaluated using three methods. The first method was to read through the surveys and tabulate the major positive and negative topics that were frequently mentioned. This produces key areas that could receive additional focus. The most beneficial attributes of the LVS identified were the articulated steering (80%) and the flexible cargo capability (75%). The most disliked attributes were; crew comfort (80%), engine power (65%), ride quality (62%), maintenance (60%), hydraulic system (55%), steering system (48%), brakes (35%), and electrical system (29%).

The second method of evaluation of the Questionnaires was to break down every response from each question and statistically tabulate the results. Although the responses were very broad, there were significant trends or issues that can be seen in the data. One result from the supervisor's survey pertains to off-road use of the LVS. Supervisors indicated a usage split of 75% on-road and 25 percent off-road. The Marines rated the LVS crew comfort as a 5.2 out of a possible 10 that was the lowest rated category surveyed. Similarly, ride quality was rated low at a 5.3. Both crew comfort and ride quality are related to the LVS suspension system that received the second lowest response. Maintainers also identified crew comfort as the worst LVS attribute.

The third method of evaluation of the surveys involved qualitative evaluation of written comments. These comments served to amplify and reiterate the statistical data obtained from the survey. Comments such as "low reliability", "high maintenance", and "time consuming maintenance" were frequent.

From the three survey evaluation methods, the key areas tabulated by the user have been identified. Operational items which should be addressed are; crew comfort, reliability, ride quality, improved cargo securing methods, more engine power, and crew ballistic protection. Maintenance issues that stood out were increased mean time between failures, easier access for maintenance, improved design for maintenance, and better maintenance manuals.

There are two reasons to review the specifications of the predecessor and similar logistic vehicle systems. The first reason is that this review provides a relative comparison of required capabilities. The second reason is to reveal what additional specification requirements should be considered for additions to the LVS specification to create the LVSR specification.

The four current vehicle specifications that have been considered during the LVSR needs analysis are; the LVS, the Palletized Load System (PLS), the Heavy Expanded Mobility Tactical Truck (HEMTT) and the Medium Tactical Vehicle Replacement (MTVR). The LVS meets the current Marine Corps heavy tactical lift requirement and was selected for review since it represents the predecessor system. The PLS and HEMTT meet the current US Army heavy and medium tactical lift requirement. These two Army vehicles, which have been produced in much larger quantities than the LVS, were selected since the combined capabilities of these trucks are similar to the LVS. The MTVR, which is still under development, is the next generation Marine Corps medium tactical truck. The MTVR was selected for this specification review since it, along with the LVSR, will be required to meet all Marine Corps heavy and medium tactical requirements in the near future.

3.2 Duty Cycle

The following duty cycle information was provided to AAI by the USMC during this concept exploration phase. Because it includes such detailed and thorough information it is duplicated here.

Mission Description The current fleet of the LVS was developed under the 1979 Required Operational Capability (ROC) for Tactical Vehicle Fleet (TVF) to satisfy the requirement to haul dimensional standardized cargo containers, shelters and functional modules from beach to the Beach Support Area (BSA), Combat Service Support Area (CSSA) and, in certain cases, to unit supply points. Some shelters, such as those outfitted as command and control centrals, would be carried into forward areas. The 1990 Revised ROC for the TVF (ROC NO. MOB 211.4.2) reflects the increased tempo and intensity of MAGTF expeditionary operations by expanding heavy TVF requirements to include transporting bulk and containerized liquid to support increasingly mobile, fuel-consuming combat vehicles. However the ROC retained the precept of tactical standard mobility of heavy vehicles. The 1993 Mission Need Statement (MNS) for the LVSR (NO. LOG 45) requires no increased mobility capability over the current fleet.

LVS Duty Profile The MNS describes the standard TVF mission day as two ten-hour shifts, with each shift including six hours of movement. The standard mission distance and speed are 140 miles and 23 miles per hour, respectively. The following course description and breakdowns are based upon the requirement of 85% on-road and 15% off-road for tactical standard mobility. These figures were derived from LVS contract DAAE07-83-C-H418 Performance Specification and were the basis for conducting LVS Initial Production Tests (IPT) at Aberdeen Proving Ground (APG) between May 1984 and April 1985. The LVS Performance Specification differentiated on/off road courses and provided test speed and payload as follows:

On Road:

(Flat) Munson High Speed Paved, Perryman High Speed Paved,
Munson Improved Gravel, Perryman A
(Secondary), Munson Belgian Block and
(Hilly) Churchville C (grades to 10%)

Off Road:

(Flat) Perryman 1,2,and 3 and
(Hilly) Churchville B (grades to 29%)

Vehicle speeds.

Vehicle test speeds may vary up to a maximum safe speed of 45 mph paved roads, 35 mph secondary roads, and 25 mph off road, depending upon course condition, weather and payloads.

<u>GCWR (lbs):</u>	On-road	Off-road
Mk48/14	150,000	105,000
Mk48/16	188,000	

<u>Payload (lbs):</u>	On-road	Off-road
Mk48/14	45,000	25,000
Mk48/16	46,000(max. kingpin load)	

<u>Mk48/14 (fully loaded) Towed load</u>	
M871 w/dolly converter	45,000 lbs
Mk14 w/towing kit	25,000 lbs

3.3 Specification Requirements Review

Each of the vehicle specifications have been reviewed to extract the specifications related to mobility and payload capacity. These specifications are summarized in **Tables 3.3-1 and 3.3-2** for each of the vehicles under review.

The initial comparison of the LVS to the other specifications reveals that the LVS is the least specified of the group. This is perhaps due to the fact that the LVS specification is the oldest. Each of the specifications shown in the summary tables will be compared in the following paragraphs.

System Weight From the system weight comparison it can be seen that the LVS, PLS and HEMTT are in the same weight class while the MTRV is significantly lighter.

Payload In the area of payload both USMC vehicles have a dual payload rating. For the USMC vehicles the on-road payloads are nearly double the off-road payload while the Army vehicles have a single payload for both on and off road transport.

Speed on Grade The speed on a 2% grade requirement for the LVS is significantly lower than the comparison vehicles.

Side Slope Performance In the area of side slope performance the payload center of gravity location is not specified for the LVS and the HEMTT while it is specified for the PLS and the MTRV. Because the heaviest loads expected for

the LVSR are fully loaded ISO containers the 24 inch payload height used for the PLS and MTVR may not representative of the worst case LVSR load.

Vehicle Cone Index Vehicle cone index (VCI) is used to assess the vehicle soft soil crossing capability. A vehicle with a lower VCI rating performs in soft soils. In the area of VCI the LVS has no specification requirement.

Turning Diameter The most discriminating feature of the LVS is its small turning diameter. The added turning capability of the LVS is due to its unique articulated design. A small turning diameter is required for the LVS to allow it to negotiate tight turns aboard transport ships and during cross country operation.

Ride Quality Both the LVS and HEMTT specification do not address ride quality. The PLS specification has limited ride quality requirements while the MTVR is highly specified.

Mobility Specifications The PLS, HEMTT and MTVR specifications include requirements established using the NATO Reference Mobility Model (NRMM). The LVS specification does not include NRMM requirements.

Table 3.3-1 Vehicle Specifications

	Vehicle Designation			
	LVS Mk48-14	PLS	HEMTT M977	MTVR
System Weight				
Curb	41,400 lbs.	51,750 lbs.	40,000 lbs.	28,000 lbs.
GVW on road	86,400 lbs.	88,000 lbs.	62,000 lbs.	58,000 lbs.
GVW off road	71,000 lbs.	88,000 lbs.	62,000 lbs.	42,000 lbs.
GCW on road	150,000 lbs.	NS*	100,000 lbs.	75,000 lbs.
GCW off road	105,000 lbs.	NS*	100,000 lbs.	59,000 lbs.
Payload				
On highway	45,000 lbs.	36,250 lbs.	22,000 lbs.	30,000 lbs.
Off highway	25,000 lbs.	36,250 lbs.	22,000 lbs.	14,000 lbs.
Speed on Grade @ GVW				
0%	45 mph	55 mph	55 mph **	55 mph
2%	26 mph	50 mph	50 mph	55 mph
3%	26 mph	NS	40 mph	45 mph
10%	NS	NS	NS	NS
30%	NS	0+	0+	NS
60%	0+	NS	0+**	2 mph ****
Side Slope Performance				
Payload	25,000 lbs	36,250 lbs.	22,000 lbs.	14,000 lbs.
CG Height Above Bed	NS	24"	NS	24"
Tire Pressure	NS	NS	NS	NS
Percent Side Slope	30%	30%	30%	30% @ 15 mph sinusoidal 40% @ 5 mph sinusoidal
Vehicle Cone Index				
Single Pass	NS	34 w/o MHC	29	25
Turning Diameter				
Center-line outside tire	<4x Wheelbase <83'	Turn between two 30' roads.	<6x Wheelbase 105' max	NS
Ride Quality				
Max. 6 Watts Input to Drivers Seat for Given Course Profile				
0.7" RMS	NS	17 mph	NS***	NS
1" RMS	NS	NS	NS	27 mph
1.5" RMS	NS	12 mph	NS	20 mph
2" RMS	NS	NS	NS	15 mph
4" RMS	NS	NS	NS	10 mph
Max. 2.5 G's over obstacle				
8" Half Round	NS	12 mph	NS	NS
10" Half Round	NS	NS	NS	20 mph
12" Half Round	NS	NS	NS	10 mph

* Vehicle must be able to tow a trailer with a 36,250 lb. payload.

** @ GCW

*** Spring and Damping Criteria Specified.

**** @ off road payload

Table 3.3-2 Vehicle Mobility Specifications

	LVS	PLS	HEMTT	MTVR
<i>Mobility Rating Speeds</i>				
West Germany Dry	NS	Yes	Yes	Yes
West Germany Wet	NS	Yes	Yes	Yes
West Germany Snow	NS	Yes	Yes	Yes
Mid-East Dry	NS	Yes	Yes	Yes
Mid-East Wet	NS	Yes	Yes	Yes
Mid-East Sand	NS	Yes	Yes	Yes
Korea Dry	NS	NS	NS	Yes
Korea Wet	NS	NS	NS	Yes
<i>Maximum Percent NO-GO</i>				
West Germany Dry	NS	Yes	Yes	Yes
West Germany Wet	NS	Yes	Yes	Yes
West Germany Snow	NS	Yes	Yes	Yes
Mid-East Dry	NS	Yes	Yes	Yes
Mid-East Wet	NS	Yes	Yes	Yes
Mid-East Sand	NS	Yes	Yes	Yes
Korea Dry	NS	NS	NS	Yes
Korea Wet	NS	NS	NS	Yes
<i>Mobility Characteristics</i>				
PV100	NS	NS	NS	Yes
SV100	NS	NS	NS	Yes
TV90	NS	NS	NS	Yes
V80 Cross Country	NS	NS	NS	Yes
V50 Cross Country	NS	NS	NS	Yes

3.4 Mission Need Statements

The Mission Need Statement for the LVSR was approved 22 October 1993 by the Marine Corps Systems Command and has been updated as recently as 6 June 1997. The CDTs ID for the MNS is 93295DO and the MCCDC No. is Log 45. The MNS presents the Mission, Threat, Potential Material Alternatives and Constraints for the LVSR.

The potential material alternatives described include:

- a. Non-developmental Item
 - (1) Procure a US Army Vehicle of equivalent weight class.
 - (2) Procure an off-the-shelf commercial vehicle.
- b. Inspect and repair only
 - (1) Replace worn components with new in stock components.
 - (2) Replace worn components with product improved components.
- c. Rebuild the Existing LVS
 - (1) Rebuild with new in-stock components.
 - (2) Rebuild with product improved components.
- d. Research and Development.
 - (1) Field a new truck.

During this study AAI has concentrated primarily on Alternative c.

In the area of Mobility the MNS is not very specific. The MNS states that the LVSR is required to be capable of conducting expeditionary operations over a variety of geographic-climatic conditions. Also within the mobility section the MNS states that the size of the LVSR is restricted to equal or smaller than the LVS.

In the area of Transportability, internal transport via C130 and external transport via CH53E helicopter is specified. This need for helicopter transportability requires that the LVSR can be disassembled into light enough sections to be air-lifted and transported the necessary distance.

Desired Mission Capabilities discussed in the MNS related to mobility include;

- Highway speed of 55 mph on grades fully loaded in tandem tow configuration
- Safely transport 4 fully loaded SIXCONS
- Improved marginal terrain capability when loaded to 12.5 tons
- 60 inch fording capability without kit
- equal or greater fuel economy than the existing LVS

3.5 Highway Transportability Restrictions

Consideration must be given to all applicable federal and state laws for both size and weight limitations. This must be done to ensure unhindered transport to any destination within the continental US.

Though given that the LVSR is restricted to the original size envelope of the LVS, consideration must be given to all current federal and state laws to ensure compliance. Maximum Vehicle height restrictions vary state to state from 13.5 feet to 14 feet. Therefore vehicle design should limit maximum height to 13.5 feet including any packaging equipment or cargo. To be compliant in all states the vehicle without towed load should be limited to 40 feet in overall length. Maximum vehicle width is 102 inches on the interstate highway system. However most states restrict this to 96 inches on state highways and secondary roads. To ensure unhindered transport the maximum width must not exceed 96 inches.

Due to several new laws being passed in recent years as well as stricter enforcement of existing laws, consideration must be given to gross vehicle weight restrictions on the nations highways. These numbers are often further reduced by the "bridge formula" as well as state mandated footprint laws.

Overall weight limitations vary widely from state to state. Restrictions on certain state secondary roads also apply. Below is a general list of restrictions and is by no means complete and is given only as a guideline. For specific route information the specific state must be contacted.

Most states limit total gross vehicle weight to 80,000 lbs on interstate highways. A few states such as Montana and Nevada allow ratings up to 129,000 lbs

State highway restrictions are somewhat similar, varying from 80,000 lbs up to as high as 164,000 lbs in parts of Michigan. There are also restrictions for single and tandem axle weight ratings. Most states limit single axles to 20,000 lbs and tandems to 34,000 lbs.

In order to protect the nations bridges, trucks today must comply to the Bridge Formula B. This a simple equation, shown below, that is used to restrict axle weights based on load, the number of axles and the distance between them.

Formula B

$$W=500(LN/(N-1) + 12N + 36)$$

where:

W = the maximum weight in pounds that can be carried on the group of two or more axles. It is rounded to the nearest 500 pounds.

L = the spacing in feet between the outer axles of any group of two or more axles. Spacing is rounded to the nearest foot, with dimensions under 6 inches rounded down and above six inches rounded up to the next foot.

N = the number of axles in the group.

The actual listing and text of the law can be found in "Title 23" of The United States Code. The results of this law for the possible LVSR suspension arrangements can be found in the following table:

Number of Axles	Total Spacing	Max. Load
2	60 inches (current LVS)	34,000 lb.
3	120 inches (tridem RBU)	43,500 lb.
4	27 feet (current LVS)	60,000 lb.
5	27 feet (tridem RBU short)	65,000 lb.
5	29 feet (tridem RBU long)	66,000 lb.

Source: Title 23 United States Code, Section 127.

Recently, many states have passed into law or are enforcing old laws to limit ground contact pressure. These laws are usually referred to as "Footprint Laws". The purpose is to limit pavement damage due to increasing axle loading. Due to difficulty in calculating the actual footprint of a loaded tire, the nominal width of the tire is used for the text of the law. A basic calculation is done to determine the load per inch width of the tire. These laws vary widely from state to state and there appears to be no trend toward standardization or uniform enforcement. The following table gives a sampling of the range of restrictions. This list is not intended to be complete and each state should be contacted for the latest up to date information.

State	Restriction
Minnesota	500 lb./in
Nevada	500 lb./in
Washington	500 lb./in
New York	800 lb./in
Pennsylvania	800 lb./in
Indiana	800 lb./in
Tennessee	No Spec.
North Carolina	No Spec.

Source: Joe Laspina, Volvo GM Heavy Truck. 3/27/97.

3.6 Federal Safety Standards

During the development of the LVSR consideration must be given to various federal safety standards that apply to motor vehicles. Two such standards will be discussed here; the Federal Motor Vehicle Safety Standards and the Federal Motor Carrier Safety Standards.

The Federal Motor Vehicle Safety Standards (FMVSS) cover all types of motor vehicles including heavy trucks. Discussing all applicable standards would be outside the scope of this report and would require a significant amount of research to complete. However, FMVSS #121: Air Brake Systems, has had a direct impact on this development program and will be discussed briefly.

FMVSS #121 establishes requirements for performance and equipment for systems on air braked vehicles. Of primary significance is section S5.1.6: Antilock Brake Systems (ABS). Per this standard all vehicles manufactured on or after March 1, 1998 must be equipped with an antilock braking system. This standard along with the USMC possible requirements to have or not have ABS should be considered as part of the refurbish/replace decision. Since a decision to replace the vehicles would force the use of ABS which will have definite cost and possible performance impacts effectiveness of ABS off-road and in certain on-road conditions must be evaluated to validate the safety of the system when used on the LVSR.

The second item of FMVSS #121 of significance to this program is the latest stopping distance tests and criteria. Outlined in section S5.3.1 is a procedure for performing all required tests as well as a table of required stopping distances for various speeds. As with the ABS, mandates for the new stopping distance requirements apply to all new trucks manufactured on or after March 1, 1998.

The Federal Motor Carrier Safety Standards deal with all items necessary for the safe operation of over the road trucks and tractors. There is some question as to the applicability of this standard to military vehicles since they are not involved with interstate commerce. Though these standards may not apply as law, they should be used as a guideline to ensure safe operation of the vehicle.

3.7 Environmental Protection Agency Requirements

In 1985 EPA regulations were not applied to military equipment. However, this has changed. Therefore, the LVSR will be required to comply with the Environmental Protection Agency regulations governing control of Air Pollution from New Motor Vehicles and New Motor Vehicle Engines, in effect on the date of contract award.

Emission standards specify the maximum amount of pollutants allowed in exhaust gasses discharged from a diesel engine. Standards were initiated in California in 1959 to control CO and HC emissions from gasoline engines. Today emissions standards have been expanded to cover on and off-road diesel engines. Components of diesel exhaust that are regulated include:

- Diesel particulate matter (PM), measured by gravimetric methods. Sometimes diesel smoke opacity measured by optical methods is also regulated.
- Nitrogen oxides (NOx), composed of nitric oxide (NO) and nitrogen dioxide(NO2). Other oxides of nitrogen that may be present in exhaust gases, such as N2O, are not regulated.
- Hydrocarbons (HC), regulated either as total hydrocarbon emissions (THC) or as non-methane hydrocarbons (NMHC). One combined limit for HC=NOx is sometimes used instead of two separate limits.
- Carbon monoxide (CO).

Emissions are measured during an engine or vehicle test cycle which is specified by the regulating standard. Regulated emissions limits are usually expressed in grams of pollutant per unit of traveled distance or in grams of pollutant per unit of mechanical energy delivered by the engine. The duty to comply with these standards is on the engine manufacturer. Typically all engine powered equipment have to be emission certified before they are released to the market.

It can be argued that the LVS could be considered either an on-road application, typical long and short haul truck application, or an off-road application such as, construction, agricultural, and generators. LVSR engine candidates have been considered as on-road for the purposes of this investigation. All standards regulations and testing apply only to engines burning diesel fuel, emissions generated while the LVSR is using JP8/JP5 will not be covered under any current guidelines.

Emission standards in effect for 1998 heavy duty diesel truck engines are:

HC	CO	NOx	PM
1.3 g/bhp	15.5 g/bhp	4.0 g/bhp	0.10 g/bhp

In 1995, the EPA, California Air Research Board (ARB) and the leading manufactures of heavy-duty diesel engines signed an agreement known as "Statement of Principals", to reduce engine emissions by pursuing a new

standard that will cut NOx emissions from new trucks in half. The goal to reduce NOx emissions from highway heavy-duty engines to levels approximately 2.0 g/bhp beginning on 2004. Manufacturers will have the flexibility to choose between two options:

1. Combined NMHC + NOx standard of 2.4 g/bhp, or
2. Combined NMHC + NOx standard of 2.5 g/bhp and a NMHC cap of 0.5 g/bhp.

A separate standard also has been proposed for mobile off-road diesel engines of all sizes used in a wide range of construction, agricultural, and industrial equipment and in some marine applications. This standard could be applied to LVSR if it were considered similar to a mine haul truck or other off-road equipment.

3.8 Desired Future Enhancements

Desired Mission Capabilities discussed in the MNS (described in Section 3.4) requires enhancements in the powertrain and suspension system. Increasing the highway speed of 55 mph on grades with a fully loaded tandem tow configuration is likely to require additional power and driveline upgrades. Improving fuel economy will require as a minimum an improved engine control system. Safely transporting four (4) fully loaded SIXCONS and improving marginal terrain capability when loaded to 12.5 tons will require suspension stability and ride performance improvements.

4. Concept Exploration

The Concept Exploration phase of this program included: an initial “brainstorming” effort, identification of the preferred conceptual approach, and detailed exploration of the preferred approach.

During the initial “brainstorming” effort, eight (8) preliminary concepts were developed. The main differences in the conceptual approaches, shown in **Figure 4.0-1**, were in the areas of the trailer suspension and drivetrain. The trailer was first concentrated on since it was clear that improving off-road mobility with an increased payload would require trailer configuration changes. A brief description of the Preliminary Concepts identifying the unique attributes of each is provided in the following:

Concept 1 is an 8X8 configuration similar to the current LVS system. This configuration was primarily included to provide a reference to compare alternative systems. However, this configuration is a viable candidate since it could be upgraded cost effectively to achieve a significant performance improvement.

Concept 2 is a configuration that allows the cargo bed to be lowered 12 inches than that of the existing LVS to improve off-road stability. Tires selected are eight (8) pairs of 12.5R16.5 (HMMWV) mounted on four (4) rigid axles. **Concept 2A** is similar to Concept 2 except it employs independent suspension and electric wheel motors. This concept eliminates the cumbersome “daisy” chain configuration mechanical drivetrain that is required for Concept 2.

Concept 3 uses a tracked suspension system similar to the AAV7 on the trailer. The ground pressure of this concept is significantly reduced thus greatly enhancing marginal terrain capability. The cargo bed has approximately the same height as the existing LVS. However, improved stability is achieved by increasing the width of the trailer from 96 inches to 117 inches. In this concept the drivetrain is greatly simplified since only one differential is required to deliver power to the forward mounted AAV7 final drives.

Concept 4 uses an improved tracked suspension system similar to the AAV on the trailer. Because this vehicle uses hydro-pneumatic suspensions, the width of the vehicle can be reduced to the original LVS width of 96 inches. The height of the cargo bed is reduced 12 inches since the AAV suspension has smaller road wheels. Another unique feature of this concept is the incorporation of a dedicated trailer power plant. Power to the final drives is provided via an electric drivetrain from either the front power unit or the trailer mounted power plant. This approach achieves a power upgrade without the need to increase the front power unit engine horsepower.

Concept 5 is a 10X10 configuration similar to the Palletized Load System (PLS) with articulated steering. The addition of an axle to the 8X8 LVS provides the potential for reduced ground pressure and improved side slope stability. The position of the axles can be varied to achieve the desired loading distribution.

Concept 6 is a reduced cargo bed height configuration using eight (8) "super singles" that are smaller than the tires presently used on the LVS. Four (4) pairs of A-arm type independent suspension are used. A mechanical driveline is used to deliver power from the front power unit.

Concept 7 is similar to Concept 6 with the only modification being the use of a trailing arm type suspension system.

Concept 8 is based on Concept 6 with an electric drivetrain employing electric wheel motors.

At the conclusion of the "brainstorming" effort the advantages and disadvantages, shown in **Table 4.0-1**, of the Preliminary Concepts were compared. These analyses were reviewed with the Government and it was decided that Concept 5 warranted a detailed exploration.

During this concept exploration AAI has focused on four areas of mobility enhancement:

- 1) Payload enhancement
Increase off-road payload to 35,000 minimum (45,000 desired)
- 2) Power Plant Upgrade
Increase power plant capacity to achieve improved performance with improved fuel economy and reduced pollution
- 3) Suspension Upgrade
Increase ride and stability of the existing system while also increasing off-road payload to 35,000 minimum (45,000 desired)
- 4) Terrain Adaptive Technology
Improve mobility and safety by applying new automotive technologies

The following paragraphs detail the analysis and finding from each of the above study areas. These studies have concentrated on the Logistics Variant Mk48/14.

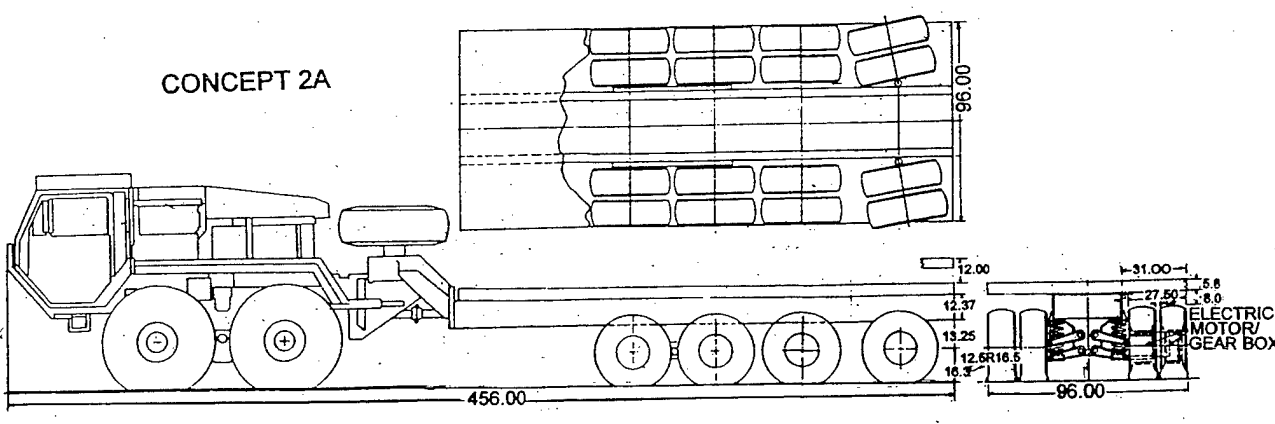
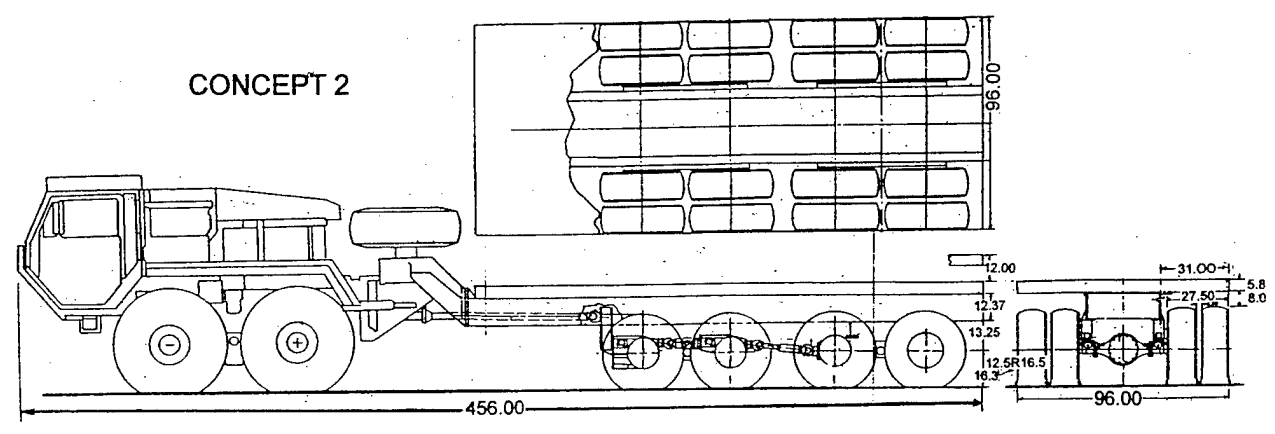
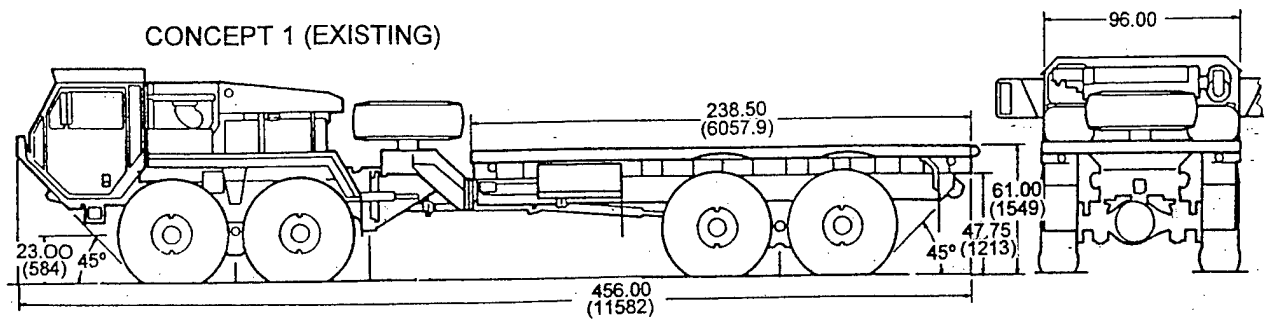

Figure 4.0-1a Preliminary LVSR Concepts

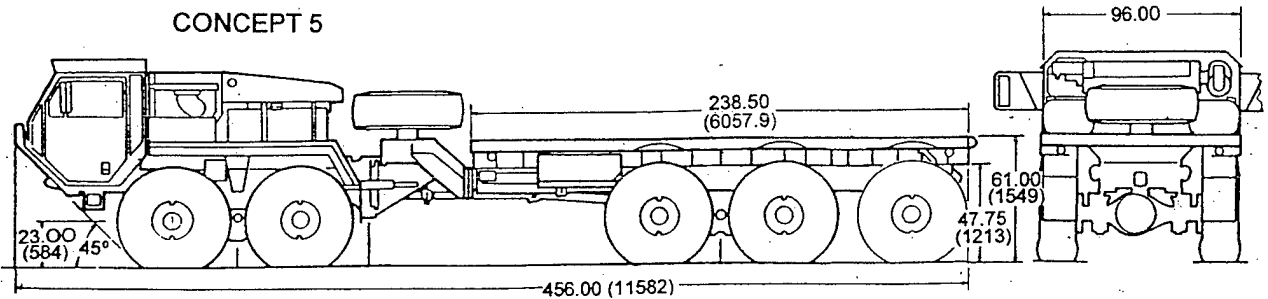
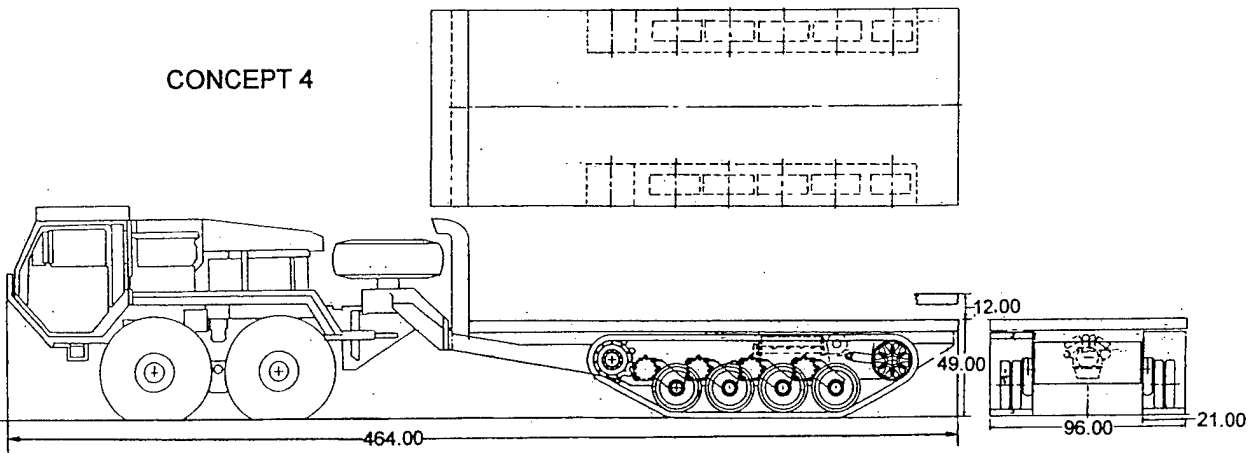
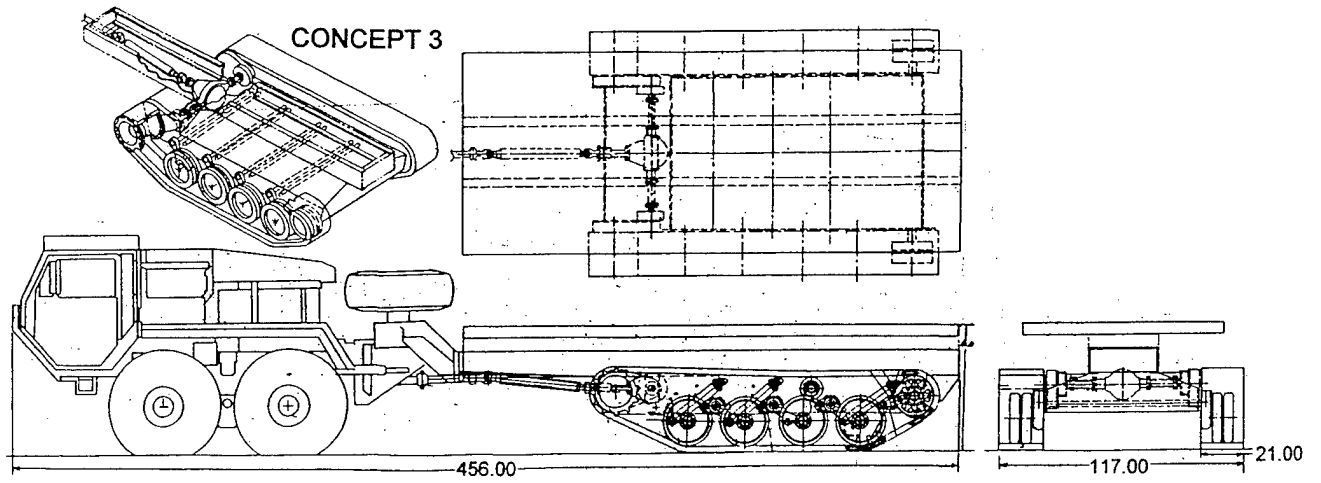

Figure 4.0-1b Preliminary LVSR Concepts

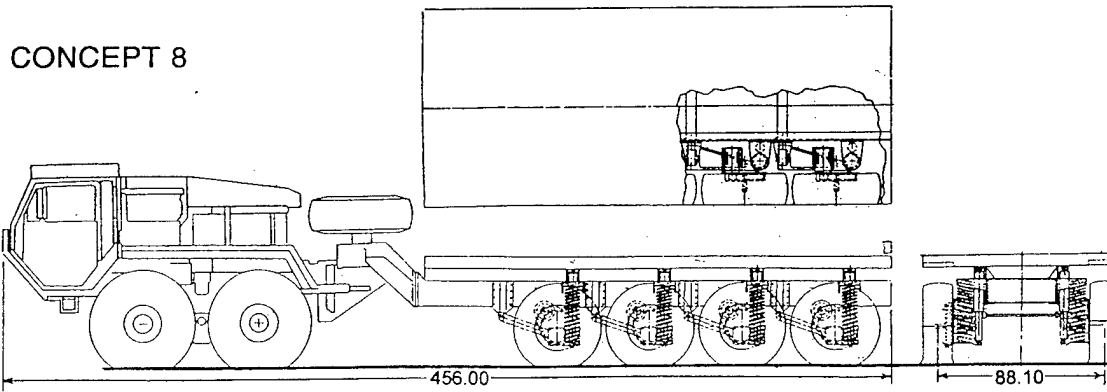
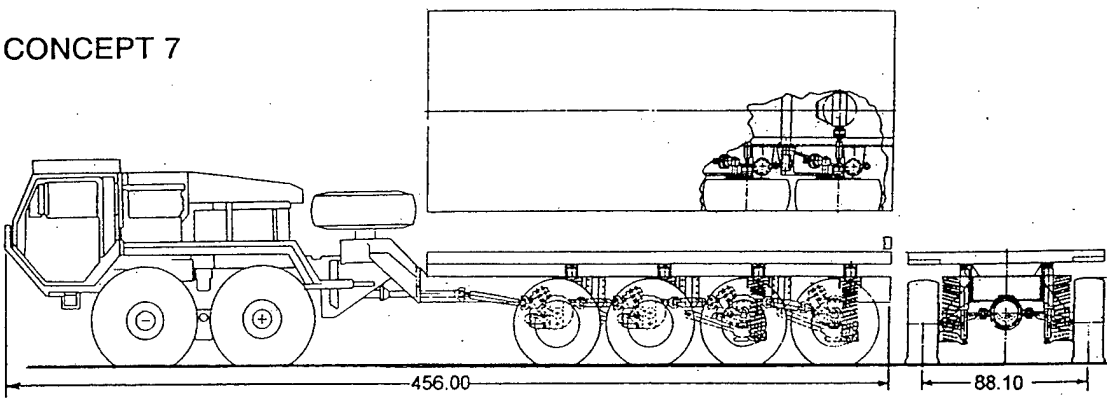
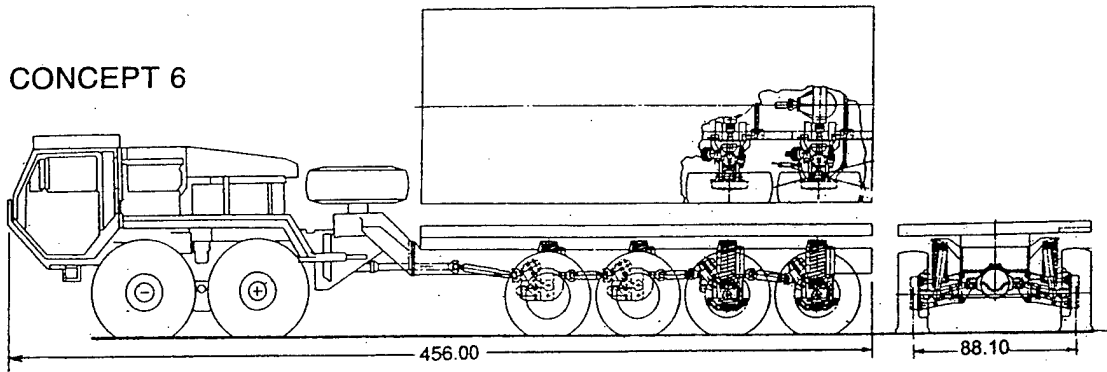

Figure 4.0-1c Preliminary LVSR Concepts

Table 4.0-1 Preliminary Concept comparison

Concept Number	Advantages	Disadvantages
1	Few changes required, may provide lowest cost solution for 17.5 ton off-road capability	No possibility for 22.5 ton off-road capability
2	Lower cargo bed Improved stability	Increased logistics burden, two tire sizes, more complex than existing, marginal ride improvement. Small tires may reduce soft soil mobility.
2A	Lower cargo bed Improved stability	Increased logistics burden, electric drive adds development cost and risk.
3	Greatly increased soft soil capability. Greatly enhanced stability.	Increased logistics burden, two tire sizes. High track maintenance, too wide and low acceptance.
4	Greatly increased soft soil capability. Enhanced stability.	Increased logistics burden. High track maintenance, electric drive adds development costs and low acceptance.
5	Low risk solution High acceptance Provide potential for 22.5 ton off-road capability Improved mobility potential	High cargo deck
6	Lower cargo bed Improved mobility potential	Increased logistics burden, two tire sizes, increased mechanical complexity
7	Lower cargo bed Improved mobility potential	Increased logistics burden, two tire sizes, increased mechanical complexity
8	Lower cargo bed Improved mobility potential	Increased logistics burden, two tire sizes, electric drive increases development costs

4.1 Payload Enhancement

Payload enhancement investigations began with an assessment of the off-road limitations of the current LVS. The current LVS payload rating is 12.5 tons off-road and 22.5 tons on-road. These investigations indicate that the off-road payload is limited by soft soil mobility, side slope stability and tire load capacity. A system level block diagram of the existing LVS is shown in **Figure 4.1-1**.

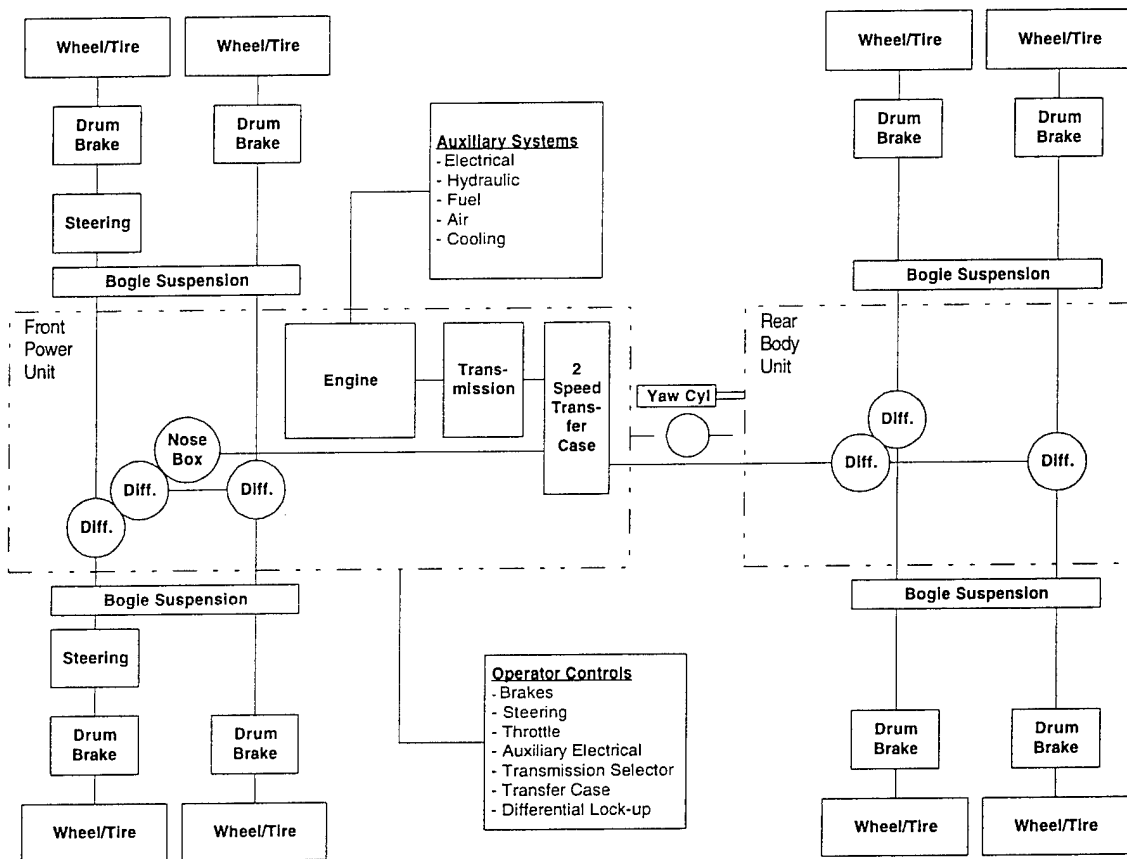

Figure 4.1-1 Functional LVS Block Diagram

The LVS is an 8X8 wheeled vehicle equipped with Oshkosh Truck Company bogie type suspension systems arranged as shown in **Figure 4.1-2** and **4.1-3**. The front suspension employs three (3) leaf springs four (4) inches wide with a steel saddle and six (6) torque rods. The rear suspension employs three (3) leaf springs five (5) inches wide with a steel saddle and six (6) torque rods. The front suspension is equipped with shock absorbers located near the end of each bogie spring for a total of four (4) shock absorbers employed. The rear suspension is undamped. The eight (8) tires are Goodyear 16.00R21 radials with AT2A tread.

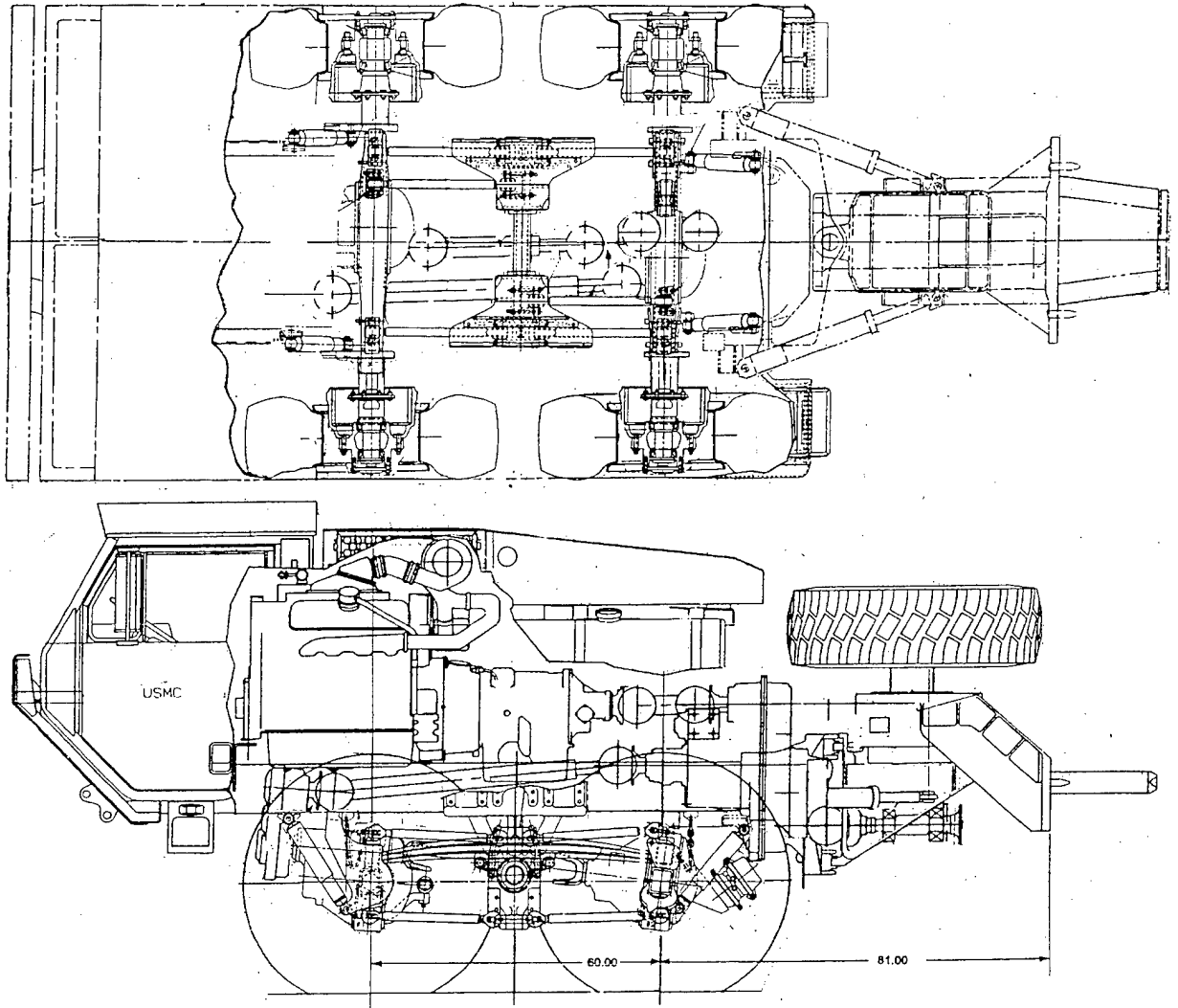

Figure 4.1-2 Baseline LVS Front Power Unit equipment arrangement

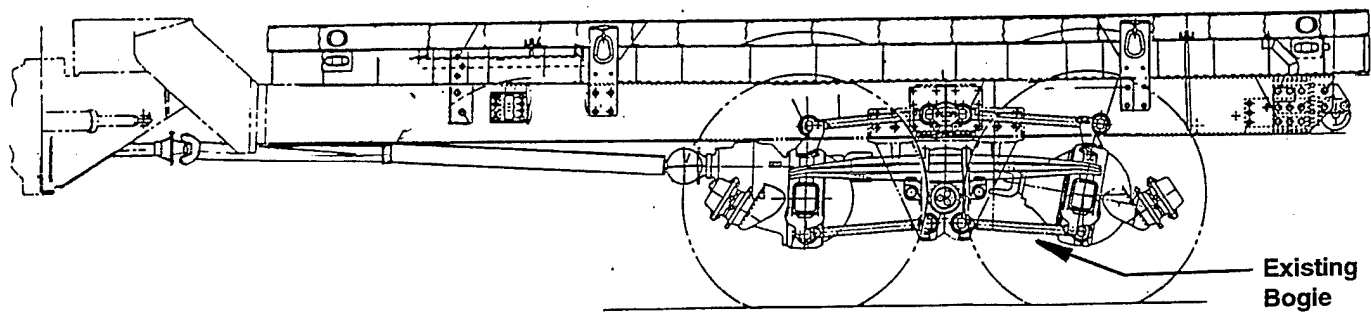
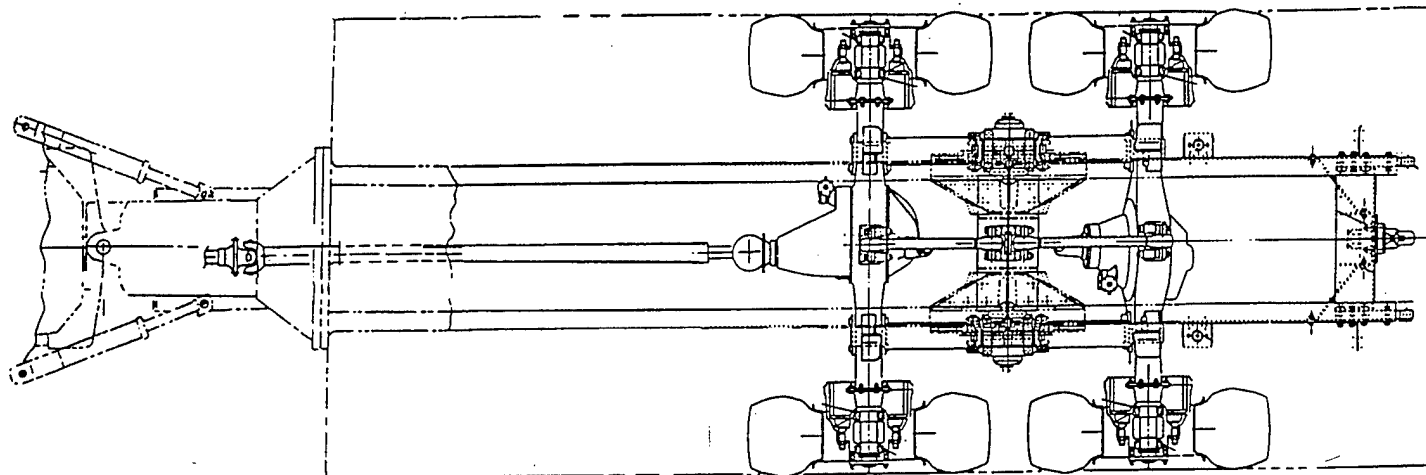

Figure 4.1-3 Baseline LVS Rear Body Unit equipment arrangement

The engine is a Detroit Diesel 8V92TA rated at 445 brake horsepower. The drivetrain consists of an Allison HT740D transmission powering an Oshkosh 2-speed transfer case. Under normal operation the transfer case delivers a 50/50 torque split to the front and rear bogies. The drivetrain arrangement on the front power unit (FPU) requires the use of a “nose box” located on the front axle. Eaton RS-381 axles are used on the FPU and Eaton DS-580 are used on the RBU. An inter-axle differential provides 50/50 torque split to the front and rear axles of the bogie. Each axle is also equipped with a wheel-to-wheel differential that distributes 50 percent of the applied torque to each wheel. For improved traction a driver activated air operated system is used for selectively locking the differentials in the transfer case, inter-axle differential and wheel-to-wheel differentials.

To determine the impact of various payloads on axle loading and mobility AAI developed a mass properties model of the LVS. The weight and center of gravity of the LVS were determined using the published axle loading information shown in **Table 4.1-1**. As shown in the table, information on many of the LVS variants was collected. The mass properties model of the LVS was used to determine both the sprung and unsprung properties of the LVS logistics variant with various payloads. The results of the model are shown in **Table 4.1-2**. Throughout this report, the four payload configurations that have been examined are:

Payload	Weight (lbs.)	Vertical Location (inches)	Horizontal Location
None	0	na	na
A	25,000	24 above bed	Center of bed
B	35,000	36 above bed	Center of bed
C	45,000	48 above bed	Center of bed

Table 4.1-1 Tabulation of Axle Weights and Centers of Gravity for the LVS Family

Vehicle Type	Axle Weights (lbs.)				Landing Gear	GVW (lbs.)	Payload (lbs)	Source*	CG from Front axle CL, (in.)	CG from Rear axle CL (trailers)	Vertical CG from ground
	#1	#2	#3	#4							
	Axle	Axle	Axle	Axle	(lbs.)	(lbs.)	(lbs)				
MK48/14	13910	12630	7160	7740	n/a	41440	None	Doc. C	122.6"	n/a	n/a
MK48/14	14730	13930	16950	17330	n/a	62940	21500	Doc. C	170.9"	n/a	n/a
MK48/14	16290	15340	25110	30050	n/a	86790	45400	Doc. C	196"	n/a	n/a
MK48/14	16550	14625	17225	17600	n/a	66000	25000	Doc. E	166.7"	n/a	61.2"
MK48/14	15000	13860	20280	18180	n/a	67320	25000	Doc.G	176.5"	n/a	n/a
MK48/15	13780	13080	13020	13980	n/a	53860	none	Doc. C	160"	n/a	n/a
MK48/15	16820	15670	19950	21760	n/a	74200	20340	Doc. C	175.8"	n/a	n/a
MK48/17	15550	14000	18900	18640	n/a	67090	21125	Doc. B	174.11"	n/a	n/a
MK48/17	13580	12150	10140	12030	n/a	47900	None	Doc. C	150.1"	n/a	n/a
MK48/18	n/a	n/a	n/a	n/a	n/a	n/a	None	Doc. F	149.5"	n/a	n/a
MK48/18A1	14260	13100	8190	7520	n/a	43070	None	Doc. A	123.2"	n/a	n/a
MK48/18A1	14250	12650	8110	7460	n/a	42470	None	Doc. A	123.4"	n/a	n/a
MK48/18A1	14370	12680	8180	7590	n/a	42820	None	Doc. A	123.8"	n/a	n/a
MK48 only	12770	13120	n/a	n/a	n/a	25890	None	Doc. C	30.4"	n/a	n/a
MK48 only	25000 total on data plate			n/a	n/a	n/a	None	Doc. H	31"	n/a	49"
MK14 only	n/a	n/a	6630	6750	2660	16040	None	Doc. C	n/a	51.3"	n/a
MK14 only	n/a	n/a	16000 total on data plate		n/a	n/a	None	Doc. D	n/a	32.5"	n/a
MK14 only	n/a	n/a	n/a	n/a	n/a	n/a	None	Doc. D	n/a	n/a	37"
MK15 only	n/a	n/a	12390	13070	2820	28280	None	Doc. C	n/a	42.2"	n/a
MK17 only	n/a	n/a	11110	10780	n/a	21890	None	Doc. C	n/a	30.45"	n/a
MK18A1 only	n/a	n/a	6100	7210	6120	19430	None	Doc. A	n/a	69.2"	n/a
MK18A1 only	n/a	n/a	6340	7120	6010	19470	None	Doc. A	n/a	68.8"	n/a
MK18A1 only	n/a	n/a	6210	7170	6085	19465	None	Doc. A	n/a	69.1"	n/a

- Doc. A** MK18A1 Acceptance Tests
- Doc. B** Abbreviated Test Report For The Stability Test Of the U.S. Marine Corps Logistics Vehicle System. TECOM Project Number: 1-VS-000-LVS-0002, YPG Number: 94-053
- Doc. C** Initial Production Test of the USMC Logistics Vehicle System, TECOM Project Number: 1-VG-120-LVS-001
- Doc. D** Source: MK14 Data Plate, Location: ATC Aberdeen, MD, Date: 5/8/97, Person: Steve Miller (AAI)
- Doc. E** WES Report On MK48-14, File: vehicles\nmmii\mk48.dat
- Doc. F** Proposal for MK18 Self Loading Ribbon Bridge Container Transporter, Solicitation M67854-93-R-2036, Jan. 1994
- Doc. G** R D & E Center Technical Report, Winter Performance Evaluation of Mobile Trac System on the MK48, Report Number: 13594, June 1993
- Doc. H** Source: MK48 Data Plate, Location: USMC Reserve Training Center, Overlea, MD, Date: 7/17/97

Table 4.1-2 Baseline LVS mass properties and axle loading

	No Payload	Payload A	Payload B	Payload C
Vehicle Properties				
Curb Weight, lbs	41000	41000	41000	41000
Vertical CG, in	44.3	44.3	44.3	44.3
Longitudinal CG, in	123	123	123	123
Payload Properties				
Payload, lbs	0	25000	35000	45000
Vertical CG, in *	0	85	97	109
Longitudinal CG, in *	0	261	261	261
GVW, lbs	41000	66000	76000	86000
Gross Vehicle Properties				
Combind weight, lbs	41000	66000	76000	86000
Vertical CG, in *	44.30	59.72	68.57	78.15
Longitudinal CG, in *	123.00	175.27	186.55	195.21
Unsprung Properties				
Unsprung Wt., lbs				
Axle 1	4208	4208	4208	4208
Axle 2	3308	3308	3308	3308
Axle 3	4008	4008	4008	4008
Axle 4	3808	3808	3808	3808
Axle Locaction from axle 1, in				
Axle 1	0	0	0	0
Axle 2	60	60	60	60
Axle 3	259	259	259	259
Axle 4	319	319	319	319
Axle Loads, lbs				
Axle 1	13525	14877	15417	15958
Axle 2	12625	13977	14517	15058
Axle 3	7525	18673	23133	27592
Axle 4	7325	18473	22933	27392
Sprung Properties				
Weight, lbs	25668	50668	60668	70668
Pitch Inertia, lb-sec ² -in	891,087	2,068,005	2,377,692	2,738,931
Vertical CG, in *	57	70.8	80.1	90.1
Longitudinal CG, in *	101	180	193.3	202.9
Axle Location from sprung LCG				
Axle 1	101	180	193.3	202.9
Axle 2	41	120	133.3	142.9
Axle 3	-158	-79	-65.7	-56.1
Axle 4	-218	-139	-125.7	-116.1
Forward Trunnion Load, lbs	18634	21338	22418	23500
Aft Trunnion Load, lbs	7034	29330	38250	47168

* Vertical CG measured from ground and Longitudinal CG measured from first axle

4.1.1 Candidate Suspension Configurations

For the payload enhancement portion of these investigations it was decided that the existing LVS suspension would be used with the addition of one axle. This additional axle would be located in front of the rear set of bogie suspensions. This vehicle configuration is named the "Reuse 10X10" because the existing suspension is being reused.

Three hardware alternatives were considered for the Reuse 10X10 additional axle installation;

- 1) A PLS third axle (consisting of a Hendrickson Air-Ride with a Meritor SVI 5MR axle)
- 2) A Meritor Independent Suspension Axle System (ISAS) and
- 3) A NEWAY AD-126 Air Ride and Meritor SVI 5MR axle

Design concepts for alternative 2 and 3 have been developed and are shown in **Figures 4.1.1-1** and **4.1.1-2**. A design study of alternative 1 was not completed since information on the suspension could not be obtained from the manufacturer. Hendrickson considers the PLS third axle suspension design to be proprietary to Oshkosh Truck Corporation

The Reuse 10X10 configurations result in what is called a tri-drive axle arrangement in the RBU. For maximum mobility it is desirable to power each of the wheels in the tri-drive with equal torque. In order to insure equal torque is available at all wheels in a tri-drive, the first axle must be equipped with a biasing differential with a torque ratio of 30 percent to the axle and 70 percent to the rear tandem. Investigations determined that bias differentials are only available on axles using hub gear reduction. Manufacturers identified during the study included: Meritor, SISU and GKN. As shown **Figures 4.1.1-1** and **4.1.1-2** the hub reduction gearing requires a different wheel offset than is used on the current LVS. It is unlikely that a mis-match in wheel offsets is a viable vehicle configuration. Therefore, the Reuse 10X10 will require more changes than simply adding an axle. Changes in the LVS required to effect the Reuse 10X10 are:

- 1) Added axle with biased differential and suspension
- 2) Reconfigure drive shafts
- 3) Change all wheel on existing axles
- 4) Add spaces on existing axles or replace axles for wheel offset
- 5) Modify or replace transfer case to add biased differential

The mass properties analysis of the Reuse 10X10 is shown in **Table 4.1.1-1**.

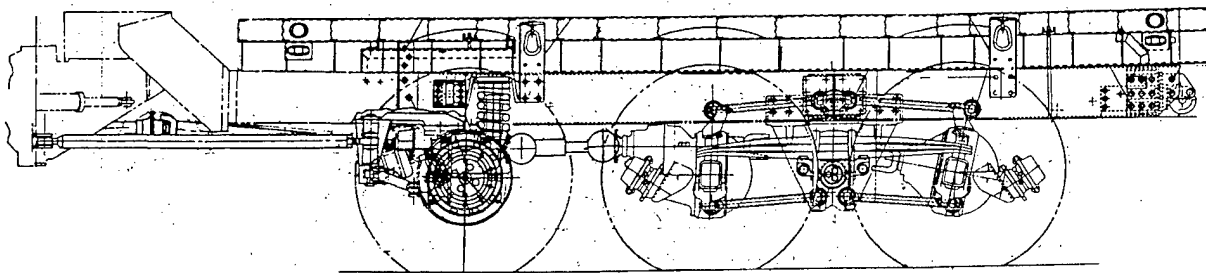
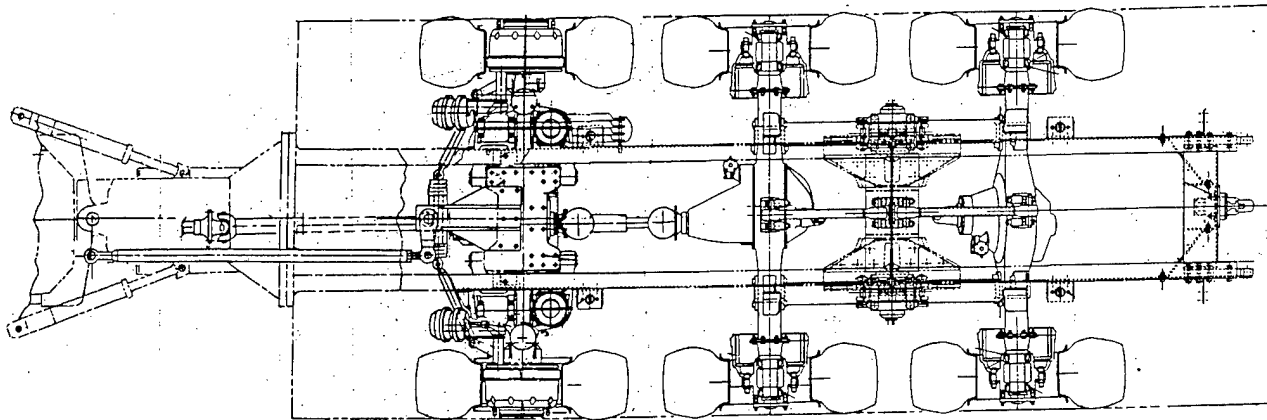

Figure 4.1.1-1 Reuse 10X10 RBU with Meritor ISAS

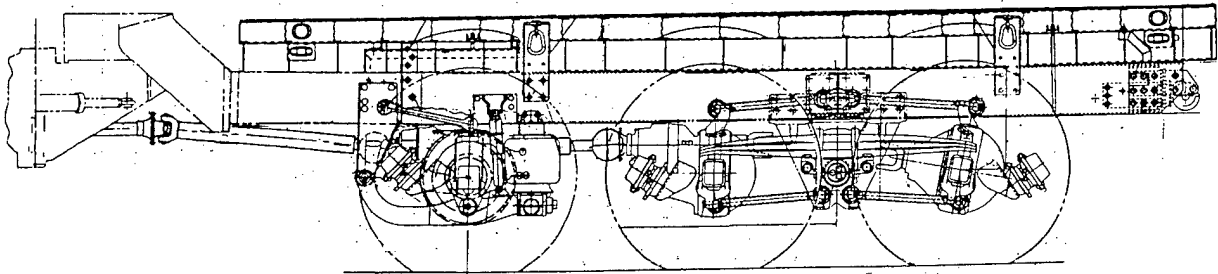
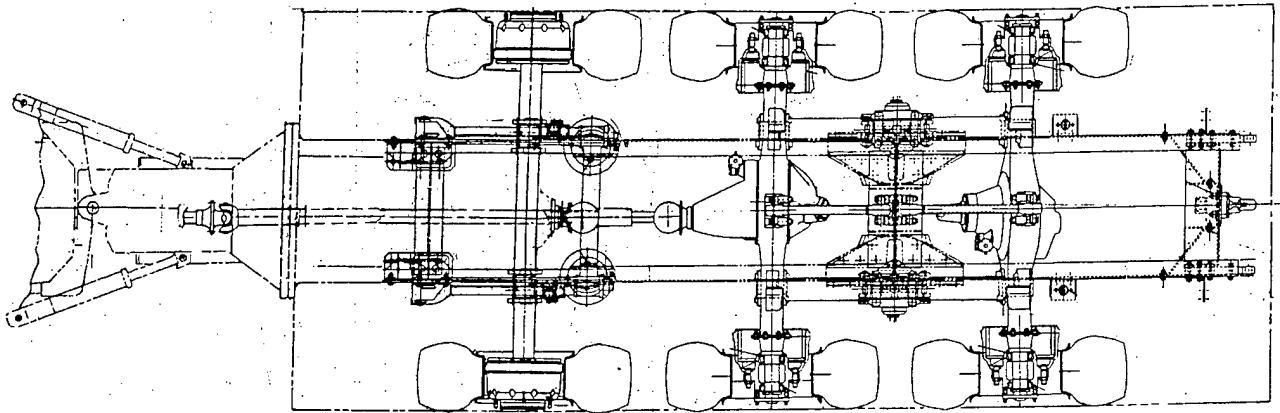

Figure 4.1.1-2 Reuse 10X10 with NEWAY Air Ride

Table 4.1.1-1 Reuse 10X10 mass properties and axle loading

	No Payload	Payload A	Payload B	Payload C
Vehicle Properties				
Curb Weight, lbs	44833	44833	44833	44833
Vertical CG, in	42.6	42.6	42.6	42.6
Longitudinal CG, in	129.5	129.5	129.5	129.5
Payload Properties				
Payload, lbs	0	25000	35000	45000
Vertical CG, in *	0	85	97	109
Longitudinal CG, in *	0	261	261	261
GVW, lbs	44833	69833	79833	89833
Gross Vehicle Properties				
Combine weight, lbs	44833	69833	79833	89833
Vertical CG, in *	42.60	57.78	66.45	75.86
Longitudinal CG, in *	129.50	176.58	187.15	195.37
Unsprung Properties				
Unsprung Wt., lbs				
Axle 1	4208	4208	4208	4208
Axle 2	3308	3308	3308	3308
Axle 3	2073	2073	2073	2073
Axle 4	4008	4008	4008	4008
Axle 5	3808	3808	3808	3808
Axle Location from axle 1, in				
Axle 1	0	0	0	0
Axle 2	60	60	60	60
Axle 3	199	199	199	199
Axle 4	259	259	259	259
Axle 5	319	319	319	319
Axle Loads, lbs				
Axle 1	13010	13305	13423	13541
Axle 2	12110	12405	12523	12641
Axle 3	6796	12878	15311	17744
Axle 4	6558	15723	19388	23054
Axle 5	6358	15523	19188	22854
Sprung Properties				
Weight, lbs	27428	52428	62428	72428
Pitch Inertia, lb-sec ² -in	936,587	2,090,913	2,422,037	2,756,986
Vertical CG, in *	55	69.3	78.5	88.6
Longitudinal CG, in *	107.3	180.6	193.5	202.8
Axle Location from sprung LCG				
Axle 1	107.3	180.6	193.5	202.8
Axle 2	47.3	120.6	133.5	142.8
Axle 3	-91.7	-18.4	-5.5	3.8
Axle 4	-151.7	-78.4	-65.5	-56.2
Axle 5	-211.7	-138.4	-125.5	-116.2
Forward Trunnion Load, lbs	17604	18194	18430	18666
3rd axle suspension load, lbs	4723	10805	13238	15671
Aft Trunnion Load, lbs	5538	20785	26883	32982

* Vertical CG measured from ground and Longitudinal CG measured from first axle

4.1.2 Trafficability

Vehicle Trafficability is used as a way of comparing the off-road performance of candidate vehicle designs. Vehicle cone index (VCI) over fine grained soils will be used to compare candidate vehicle Trafficability. This VCI will be calculated based on the empirical relationships developed by WES and incorporated into NRMM. The single pass VCI for wheeled elements, corrected for tire deflection, will be calculated since these vehicles are to be used off road. This parameter will be designated as: VCI_1 . Tire deflection data was obtained from Michelin and Goodyear. For cross country conditions a tire deflection value of 3.24 inches was used.

The methodology used herein will duplicate that utilized within NRMM to determine the single pass vehicle cone index for fine-grained soils. The loads for each axle will be calculated, and the highest axle loads will be used for the VCI_1 calculations. Individual axle loads for the Mk48/14 baseline vehicle are given in **Table 4.1.2-1**. The highest axle load for each vehicle load case, is highlighted in the table. This data will be used as a baseline, against which all other candidate concept vehicles will be compared.

Individual axle loads for the Reuse 10X10 concept vehicle are given in **Table 4.1.2-2**. **Figure 4.1.2-1** is a sample of the worksheet used to calculate VCI_1 . The results of these calculations are given in **Tables 4.1.2-3 and 4**, and are shown graphically in **Figures 4.1.2-2 and 3**.

Table 4.1.2-1 - Baseline Vehicle Axle Loads

Axle	Payload			
	Empty	12.5 Ton	17.5 ton	22.5 Ton
1	13,525	14,877	15,417	15,958
2	12,625	13,977	14,517	15,058
3	7525	18,673	23,133	27,592
4	7325	18,473	22,933	27,392

Table 4.1.2-2 - Reuse 10X10 Axle Loads

Axle	Payload			
	Empty	12.5 Ton	17.5 ton	22.5 Ton
1	13,010	13,305	13,423	13,541
2	12,110	12,405	12,523	12,641
3	6796	12,878	15,311	17,744
4	6558	15,723	19,388	23,054
5	6358	15,523	19,188	22,854

As can be seen from the data provided, the lower axle loads of the Reuse 10X10 LVSR concept vehicle, translates into an improvement in vehicle Trafficability. This improvement is between 18 and 24%, except when the vehicle is empty. The Trafficability of the empty vehicle is governed by the axle loads in the Mk48 FPU. These loads are not significantly reduced in the Reuse 10X10 LVSR candidate concept. However, the value of VCI_1 for the empty vehicle is much less than that for any load case. Better load distribution would improve this situation, but would require changes to the RBU axle locations and suspension, which will be considered in later sections.

MOBILITY INDEX FOR SELF-PROPELLED WHEELED ON FINE GRAINED SOIL (ALL WHEEL DRIVE) VEHICLES			
VEHICLE			LVS
WEIGHT (LBS)			13,525
VEHICLE CLEARANCE (IN)			13.25
ENGINE POWER (HP)			109
TIRE DESCRIPTION			16.00R20 XZL LRM
TIRE SECTION WIDTH (IN)			17.24
TIRE SECTION HEIGHT			13.37
TIRE DEFLECTION (IN)			3.24
OUTSIDE DIA OF TIRE (IN)			52.87
NUMBER OF WHEELS			2
NUMBER OF AXLES			1
TRANSMISSION (1 = AUTOMATIC, 2 =			1
CHAINS (1 = YES, 2 = NO)			2
MOBILITY INDEX			40.84
VCI_{50}			43.71
VCI_1			18.77
VCI_1 CORRECTED FOR TIRE DEFLECTION			16.65
<u>GVW</u>			
(1) CONTACT PRESSURE FACTOR	NOM TIRE WIDTH X (OUTSIDE DIA OF TIRE / 2) X NUM OF TIRES		14.834
(2) WEIGHT FACTOR	GVW / NUMBER OF AXLES =	13,525	1.501
	< 2,000 LBS	7.479	
	2,000 TO 13,500	1.496	
	13,501 TO 20,000	1.501	
	> 20,000 LBS	0.645	
(3) TIRE FACTOR	$\frac{10 + \text{TIRE WIDTH}}{100}$		0.629
(4) GROUSER FACTOR	WITH CHAINS = 1.05 WITHOUT CHAINS = 1.00		1.000
(5) WHEEL LOAD FACTOR	$\frac{\text{GVW (KIPS)}}{\text{NUM OF WHEELS}}$		6.763
(6) CLEARANCE FACTOR	$\frac{\text{VEHICLE CLEARANCE}}{10}$		1.325
(7) ENGINE FACTOR	> 10 HP / TON = 1.00 < 10 HP / TON = 1.05	16.08	1.000
(8) TRANSMISSION FACTOR	AUTOMATIC = 1.00 MANUAL = 1.05		1.000

Figure 4.1.2-1 - Sample VCI Worksheet

Table 4.1.2- 3 - Baseline Vehicle Trafficability

LVS 8X8 Mk 48/14				
VCI ₁ *	Payload			
	Empty	12.5 Ton	17.5 ton	22.5 Ton
	16.65	24.09	34.11	41.81

Table 4.1.2-4 - Reuse 10X10 Vehicle Trafficability

Reuse 10X10				
VCI ₁ *	Payload			
	Empty	12.5 Ton	17.5 ton	22.5 Ton
	16.24	19.58	26.07	33.96
% Improvement	2.46	18.72	23.57	18.78

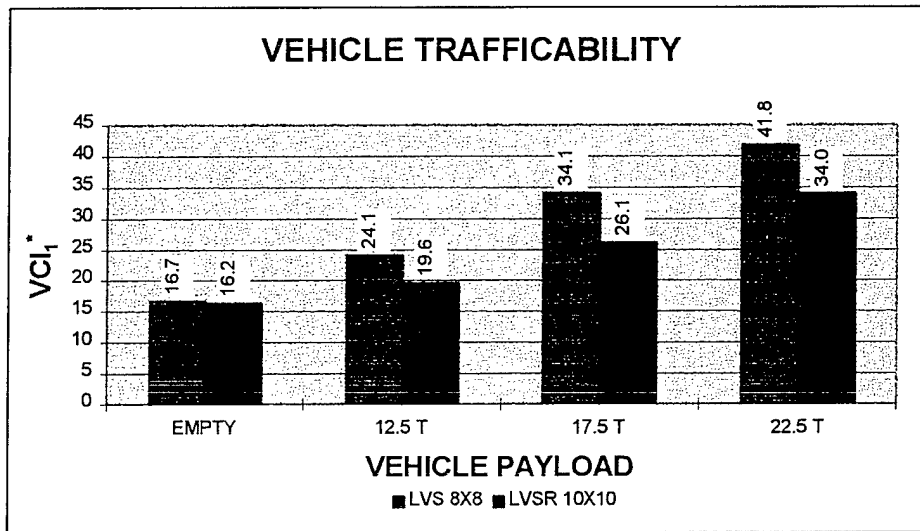

Figure 4.1.2-2 - Vehicle Trafficability Comparison

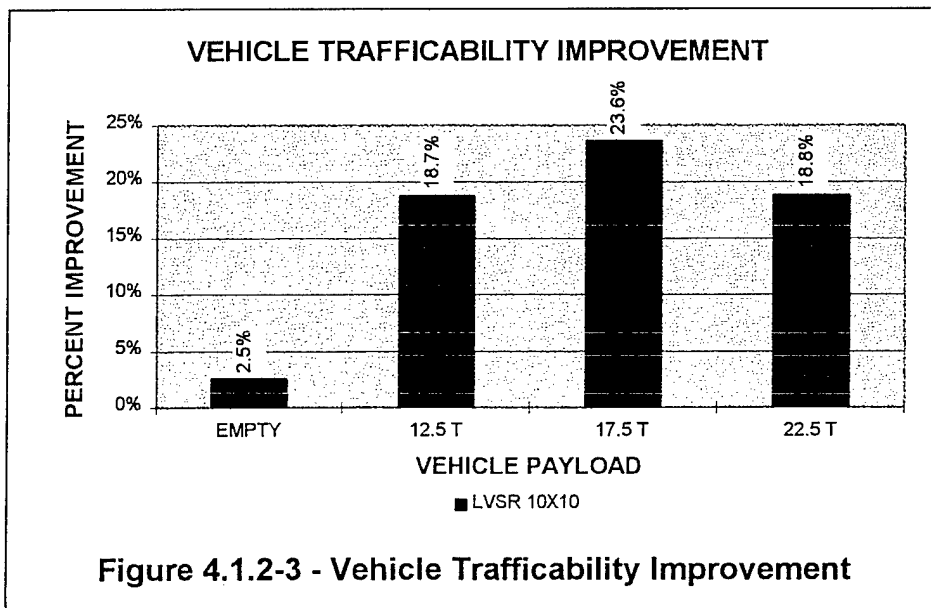

Figure 4.1.2-3 - Vehicle Trafficability Improvement

4.1.3 Ride Performance

Ride performance for all vehicles will be based on predictions obtained from VEHDYN2. This NRMM module calculates the vibration and shock exposure for the vehicle operator as the vehicle negotiates specific terrain. The performance of the Mk48/14 was calculated by VEHDYN2 and compared with experimental data for the vehicle. This data was obtained from WES, and is given in **Table 4.1.3-1**.

RMS	0.0	0.15	0.2	0.3	0.4	0.5	0.6	0.75	1.0	1.5	2.0	3.0	4.0	5.0
V _{6W}	80	80	40	30	24.5	21	18	15	13	11	9.5	8	6.5	6

Table 4.1.3-1 - WES Ride Quality Data for LVS Baseline

The VEHDYN2 input file consists of characteristic parameters of the vehicle's suspension system, tires, geometry and mass properties. Details of these pertinent parameters are shown in the following illustrations. **Figure 4.1.3-1** shows the force / deflection characteristics of the FPU bogie springs. **Figure 4.1.3-2** shows the force / deflection characteristics of the RBU bogie springs. **Figure 4.1.3-3** shows the force / velocity characteristics of the FPU shock absorbers. Tire characteristics are given in **Table 4.1.3-2**, for information provided by Michelin. **Figure 4.1.3-4** summarizes the Baseline LVS geometry, required in VEHDYN2.

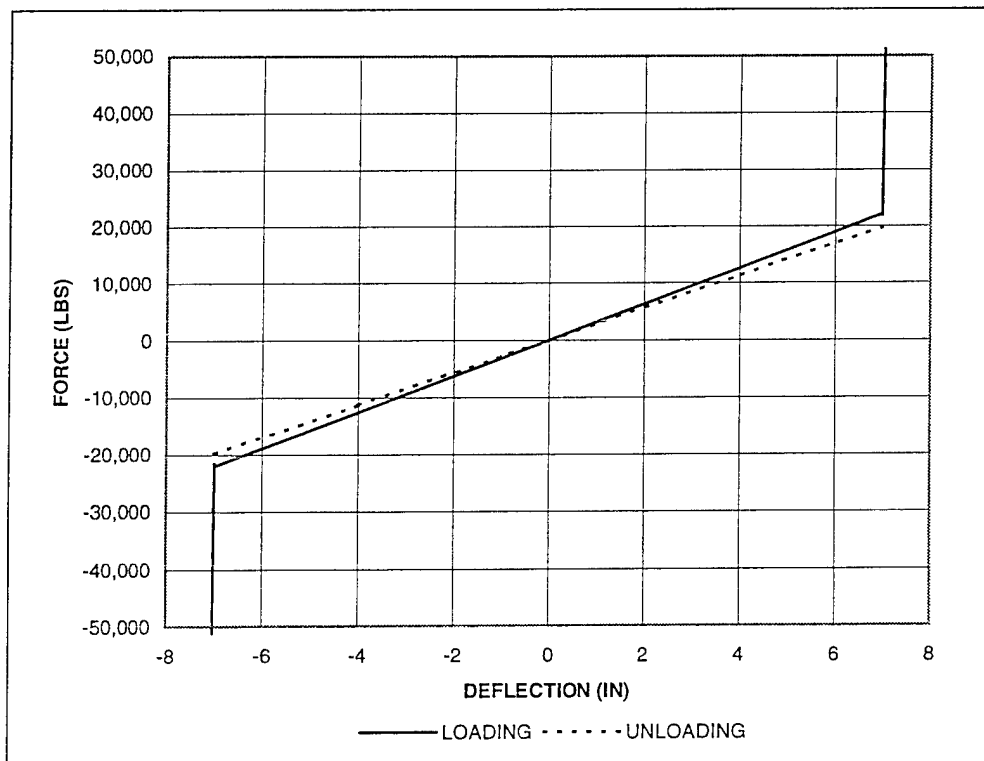

Figure 4.1.3-1 - FPU Spring Characteristics

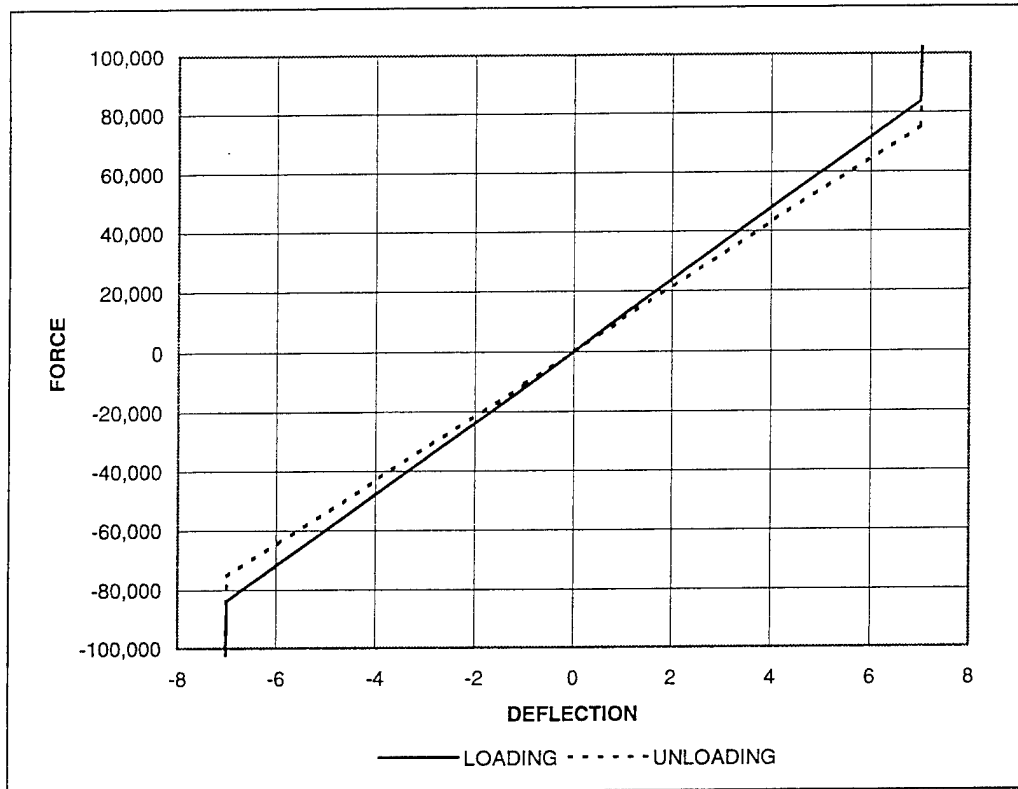

Figure 4.1.3-2 - RBU Spring Characteristics

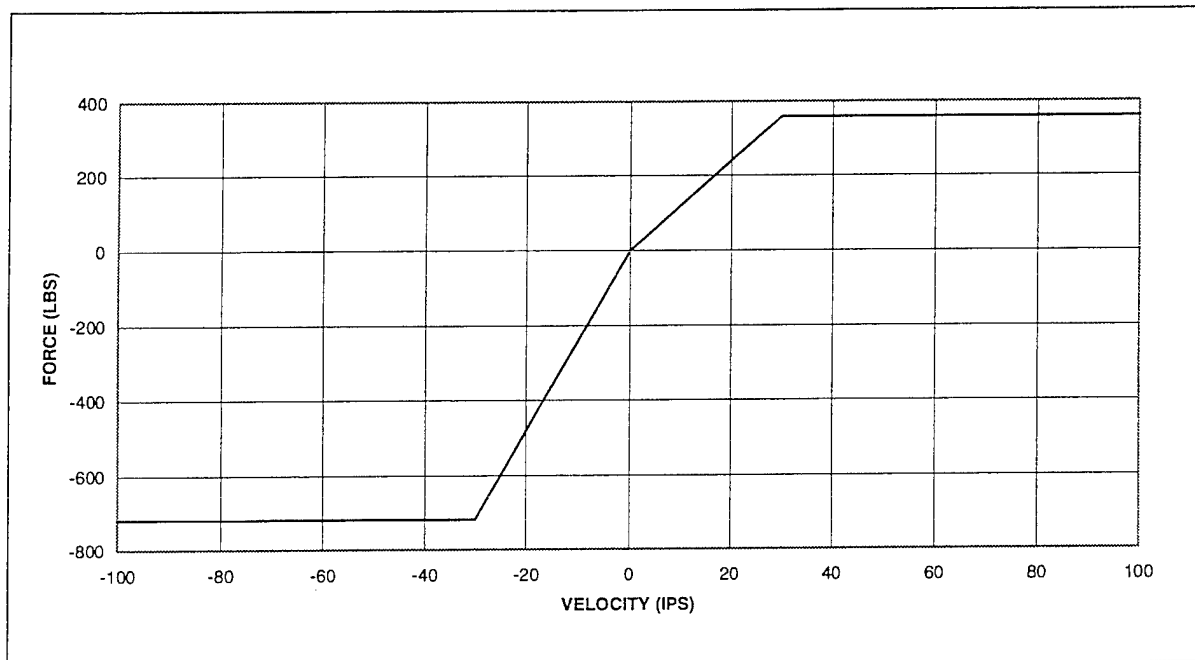

Figure 4.1.3- 3 - FPU Shock Absorber Characteristics

LOAD PER TIRE	INFLATION PRESSURE / HIGHWAY SPEED									LOAD PER TIRE	C - C	M/S/S
	SPEED (MPH)											
36,376	55.9	49.7	40.4	31.1	24.9	18.6	12.4	6.2	0.0	154	40.4	12.4
26,191								144	107	26,191		
21,826							133	117	88	21,826		
18,188						125	110	96	71	18,188		
16,733					122	113	100	87	65	16,733		
16,292				120	117	110	97	84	62	16,292		70
15,785			117	116	113	107	94	81	61	15,785		65
15,124		113	112	110	109	102	90	78	58	15,124		59
14,550	110	109	107	106	104	97	86	74	55	14,550		54
14,330	107	107	106	104	102	96	84	74	54	14,330		52
13,228	99	97	97	96	93	87	77	67	49	13,228	80	44
12,125	90	88	88	87	86	80	70	61	44	12,125	65	35
11,023	81	80	80	78	77	71	62	54	39	11,023	55	30
9,921	71	71	70	70	67	62	55	48	35	9,921	49	26
9,370	67	67	65	65	62	59	51	44	32	9,370	46	25
8,818	62	61	61	59	58	55	48	41	29	8,818	44	22
8,267	58	57	57	55	54	51	44	38	26	8,267	39	20
7,716	54	52	52	5	49	46	41	35	23	7,716	36	19
7,165	48	48	48	46	45	42	36	32	22	7,165	33	17
6,614	44	44	44	42	41	38	33	28	19	6,614	28	15
6,063	39	39	38	38	36	35	28	25	17	6,063	25	13
5,512	35	35	33	33	32	30	25	22	15	5,512	22	12
4,960	30	30	28	28	26	25	22	19	13	4,960	19	9
DEFLECTION	2.55	2.57	2.59	2.61	2.65	2.78	3.04	3.35	4.10		3.24	4.78

Table 4.1.3-2 - Michelin Tire Data

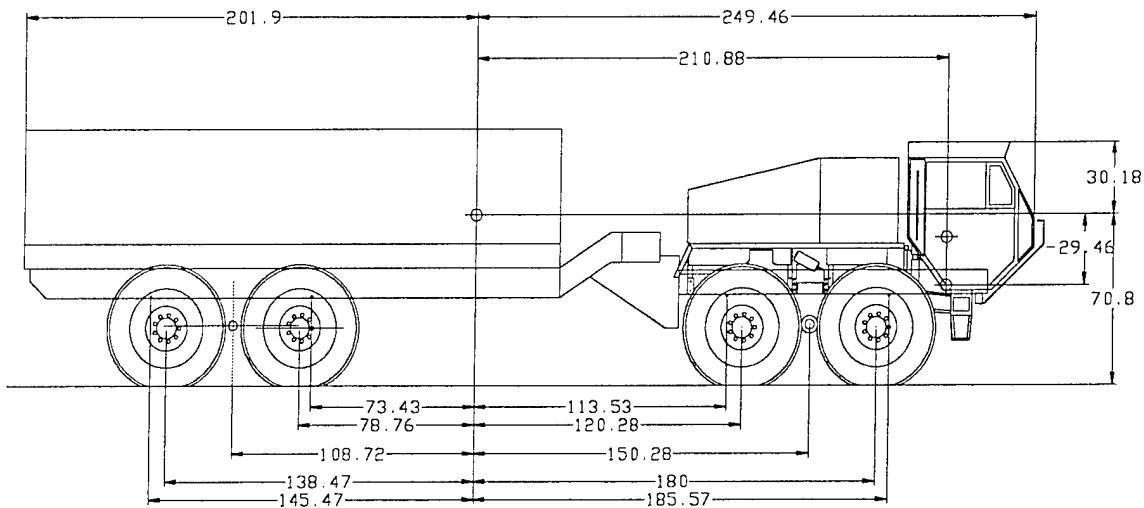

Figure 4.1.3-4 - Mk48/14 Vehicle Geometry

The predicted ride performance for the baseline Mk48/14, loaded at 12.5 tons and empty is given in **Table 4.1.3-3**. The data file, which was used to generate these predictions is given at the end of this section in **Figure 4.1.3-8**.

Terrain File	RMS (in)	LVS Mk48/14	
		12.5 Ton	Empty
CHV06	0.19	42.77	16.22
CHV01	0.34	41.80	14.35
APG37	0.66	20.00	11.20
FTK34	0.86	14.35	6.00
APG09	1.01	13.40	4.60
LET05R	1.20	13.30	4.50
YPG04	1.81	7.05	5.75
APG29	2.17	5.36	4.20
LET07L	3.27	4.50	4.20
LET08R	3.49	4.30	4.10
LET16	4.00	4.22	4.05

Table 4.1.3-3 - Baseline Limit Speed Results

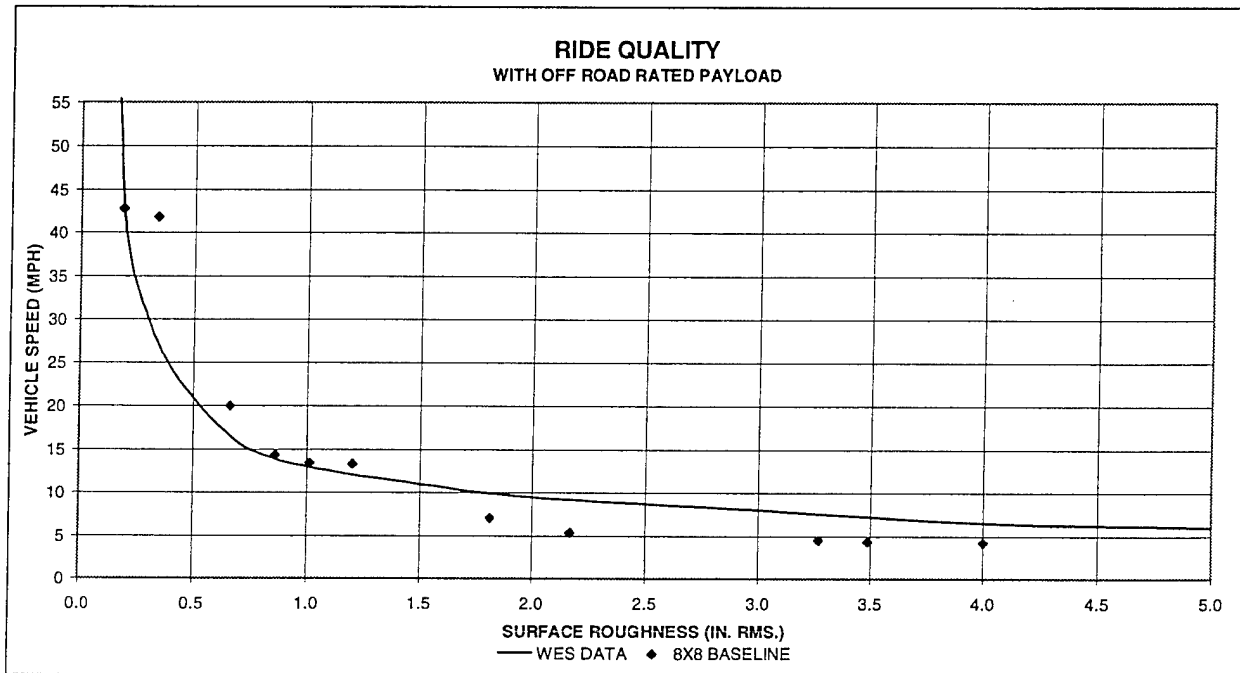

Figure -4.1.3-5 - VEHDYN2 Analyses Results

This data is compared in the graph given in **Figure 4.1.3-5**, which illustrates the acceptable degree of correlation obtained for the VEHDYN2 model. This predicted performance for the LVS (Mk48/14) will be established as the baseline for which all candidate concept vehicles will be compared for ride quality.

This model was then modified to predict the performance of the Reuse 10X10 LVSR candidate concept vehicle. Predicted performance for this vehicle is given in **Table 4.1.3-4**, and shown graphically in **Figures 4.1.3-6a and b**.

Table 4.1.3-4 - Predicted Performance for the Reuse 10X10

Terrain File	RMS (in)	Reuse 10X10	
		17.5 Ton	Empty
CHV06	0.19	41.30	> 55
CHV01	0.34	40.45	44.87
APG37	0.66	26.80	27.79
FTK34	0.86	13.97	15.52
APG09	1.01	13.13	13.58
LET05R	1.20	12.75	13.32
YPG04	1.81	12.02	11.03
APG29	2.17	5.92	6.43
LET07L	3.27	4.73	5.63
LET07R	3.49	4.45	5.26
LET16	4.00	4.27	5.08

Figure 4.1.3-6a illustrates the predicted ride performance of the Reuse 10X10 carrying a 17.5 ton payload. **Figure 4.1.3-6b** is the prediction for the vehicle with no payload.

Each graph includes the results of the baseline analyses, for comparison purposes. The predicted ride quality of the vehicle is also shown in **Figures 4.1.3-7a and b**. In these illustrations the ride quality is shown as an improvement over that predicated for the baseline vehicle.

While the ride quality improvement, shown in **Figure 4.1.3-7a**, does not indicate any significant improvement for the Reuse 10X10 candidate concept vehicle over the Baseline LVS (Mk48/14), it should be pointed out that the performance predictions are given for the vehicles at "off road rated payload". This means that while the baseline vehicle is analyzed with 12.5 tons payload, the Reuse 10X10 is carrying 17.5 tons payload. This indicates that the Reuse 10X10 LVSR candidate concept vehicle provides comparable performance to the Baseline LVS (Mk48/14) vehicle, while carrying an additional 5 tons of payload.

The predicted improvement in ride quality unloaded, as shown in **Figure 4.1.3-7b** is significant since 50% of each mission is with an empty vehicle. A 200% improvement in vehicle ride quality over 50% of the mission cycle is a very significant performance improvement.

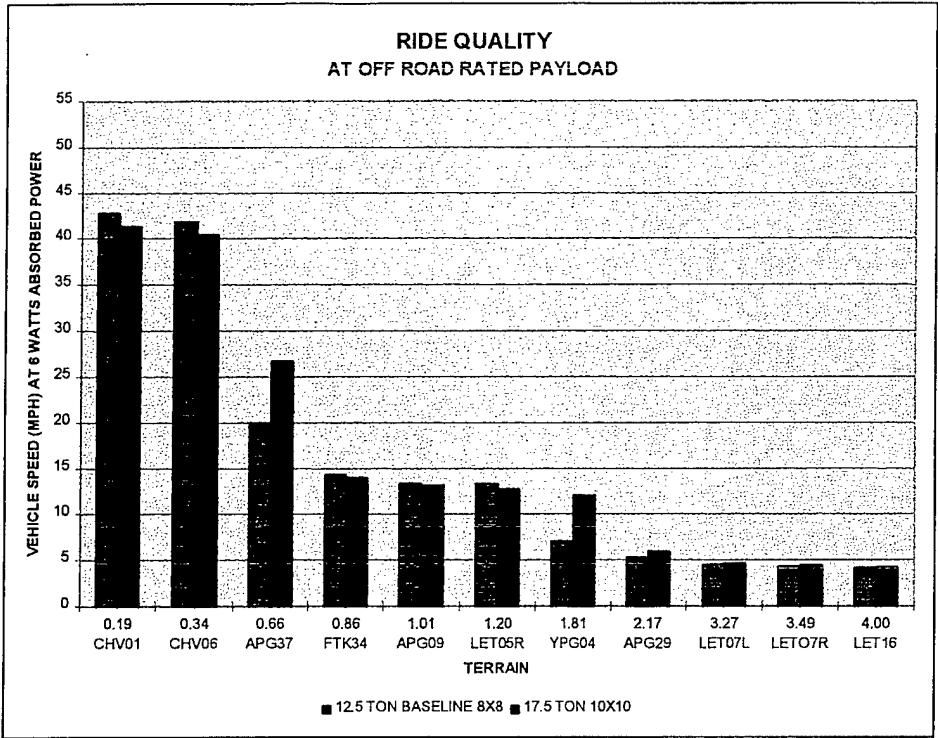

Figure 4.1.3-6a - Ride Quality Comparison (Rated Payload)

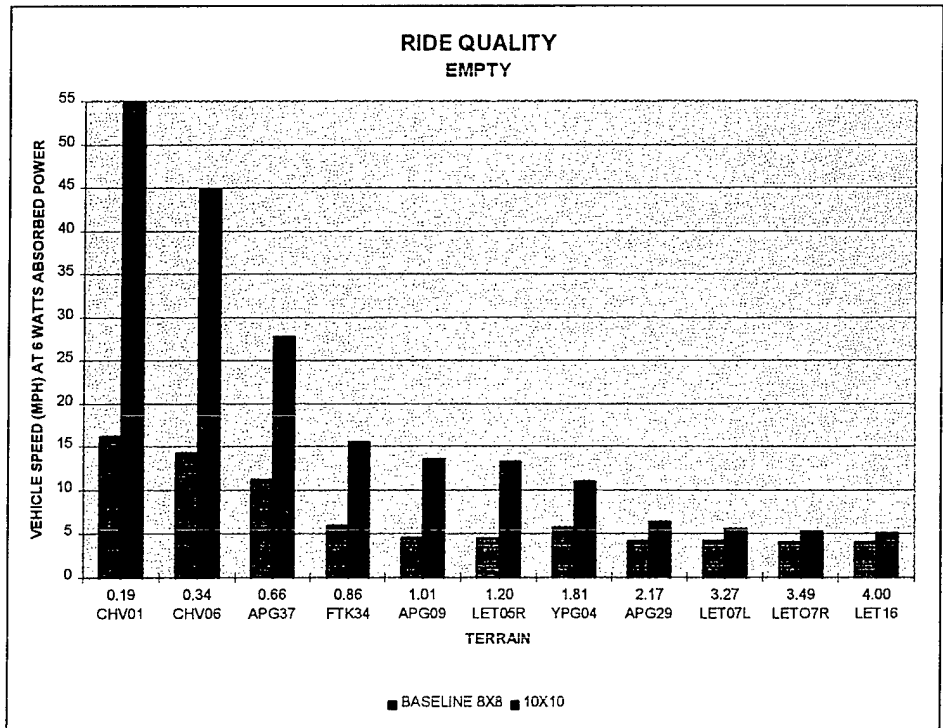

Figure 4.1.3-6b - Ride Quality Comparison (Empty)

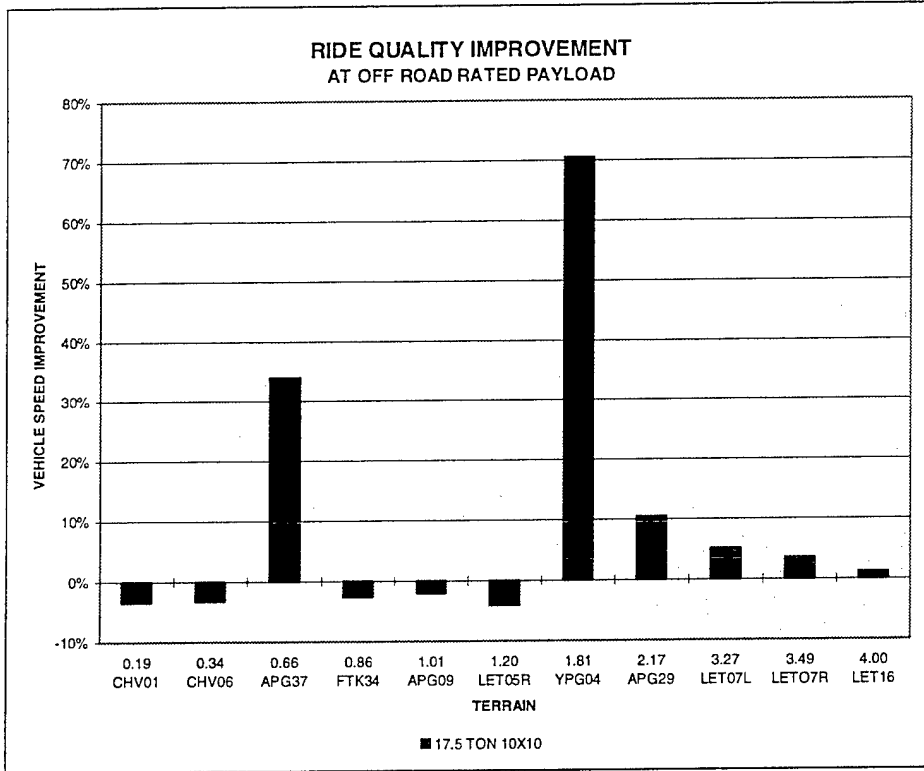

Figure 4.1.3-7a - Ride Quality Improvement (Rated Payload)

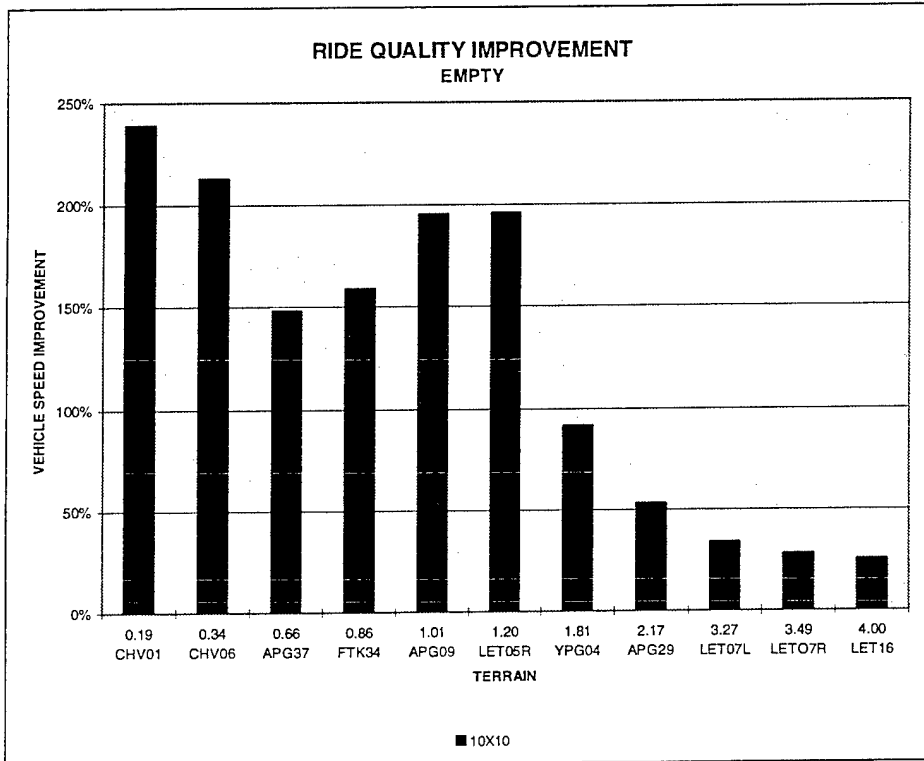

Figure 4.1.3-7b - Ride Quality Improvement (Empty)

```

LVS
LOGISTICS VEHICLE SYSTEM MK 48/14 WITH SEAT DYNAMICS (17.5T PAYLOAD)
  1  3  2  0  0
    9  9  3.000E+04  5.000E-01  3.000E+04  5.000E-01 -5.220E+00  8.780E+00
-5.470E+00 -5.220E+00 -2.220E+00  7.800E-01  1.780E+00  2.780E+00  5.780E+00
  8.780E+00  9.030E+00
-2.672E+05 -1.640E+04 -6.967E+03  2.462E+03  5.605E+03  8.748E+03  1.718E+04
  2.761E+04  2.784E+05
-5.470E+00 -5.220E+00 -2.220E+00  7.800E-01  1.780E+00  2.780E+00  5.780E+00
  8.780E+00  9.030E+00
-2.399E+05 -1.420E+04 -5.710E+03  2.776E+03  5.605E+03  8.434E+03  1.692E+04
  2.541E+04  2.511E+05
    9  9  1.000E+05  5.000E-01  1.000E+05  5.000E-01 -6.200E+00  7.800E+00
-6.450E+00 -6.200E+00 -3.200E+00 -2.000E-01  8.000E-01  1.800E+00  4.800E+00
  7.800E+00  8.050E+00
-3.271E+05 -7.409E+04 -3.824E+04 -2.387E+03  9.563E+03  2.151E+04  5.736E+04
  9.321E+04  3.462E+05
-6.450E+00 -6.200E+00 -3.200E+00 -2.000E-01  8.000E-01  1.800E+00  4.800E+00
  7.800E+00  8.050E+00
-2.934E+05 -6.572E+04 -3.346E+04 -1.192E+03  9.563E+03  2.032E+04  5.258E+04
  8.485E+04  3.125E+05
    5  0  0.000E+00  0.000E+00  0.000E+00  0.000E+00  0.000E+00  3.800E+00
  0.000E+00  1.050E+00  2.500E+00  3.800E+00  4.400E+00
  0.000E+00  1.000E+02  1.500E+02  2.000E+02  2.500E+02
    4  4  0.000E+00  0.000E+00  0.000E+00  0.000E+00
-1.000E+02 -3.000E+01  3.000E+01  1.000E+02
-7.200E+02 -7.200E+02  3.600E+02  3.600E+02
-1.000E+02 -3.000E+01  3.000E+01  1.000E+02
-6.480E+02 -6.480E+02  3.240E+02  3.240E+02
    9  0  0.000E+00  0.000E+00  0.000E+00  0.000E+00
-1.000E+02 -1.927E+01 -9.630E+00 -3.400E+00  0.000E+00  3.400E+00  9.630E+00
  1.900E+01  2.700E+01
-2.100E+02 -2.100E+02 -1.540E+02 -1.190E+02  0.000E+00  3.500E+01  1.260E+02
  2.170E+02  2.170E+02
    0  2  0  0  0  2
  4.480E+00  4.134E+01
  1.750E+02  6.449E+01  3  2
  7.600000E+04  2.377692E+06
-2.197E+02  8.010E+01  4.306E+01  1.010E+02 -4.083E+02  3.720E+01
  2.640E+01  2.104E+03 -2.640E+01  2.138E+01  3.240E+00  7.709E+03  1
  2.640E+01  1.654E+03 -8.612E+01  2.157E+01  3.050E+00  7.259E+03  1
  2.640E+01  2.004E+03 -2.851E+02  2.236E+01  3.240E+00  1.157E+04  1
  2.640E+01  1.904E+03 -3.449E+02  2.239E+01  3.210E+00  1.147E+04  1
-5.612E+01  2.510E+01  7.955E+03  5.000E+03  7.950E+01  9.000E+06
    1  1  1  0  0 -2.083E+01
    2  1  1  0  0 -9.287E+01
-3.151E+02  2.390E+01  1.043E+04  1.500E+04  8.140E+01  9.000E+06
    3  2  0  0  0 -2.798E+02
    4  2  0  0  0 -3.519E+02

```

Figure 4.1.3-8 VEHDYN2 Input File

4.2 Power Plant Upgrade

The LVSR power plant will replace the current Detroit Diesel 8V-92T mated to an Allison HT 740 as shown in **Figure 4.2-1**. The current system uses commercially produced components adapted for use on military logistics vehicles. Requirements placed on engines and transmissions in military logistics vehicles are similar to the types of loads and duty cycles these components would experience in commercial off road applications. Adapting these commercial engines for military use does not entail extensive physical changes and include NATO certification to that power level and adding diagnostic sensors to interface with STE-ICE equipment.

Both the engine and transmission used on the LVS were popular truck components when the LVS was designed and manufactured in the early 1980's. The HT 740 has been replaced by the HD series and the 8V-92's production numbers are declining and is seldom specified for new commercial truck production. The 8V-92T does not currently meet on highway EPA standards expected to be in place in the year 2000 and is not planned to be upgraded to meet these standards. Economies present in large volume production of these components for the commercial market benefit the military users by reducing the initial cost, and providing a logistic base of support for these components. Utilizing commercial truck engine and transmission manufacturers for LVS components means equipment employed on LVSR will reflect current trends in the commercial market. Many of the same market forces and regulatory requirements that influence commercial truck component design, also impact the design of trucks used by the military. A typical example of a commercially developed truck system now in production that will now be employed on LVSR are electronics now used to control diesel engines. These systems developed for commercial truck engines were developed to reduce emissions and improve fuel economy on diesel engines used on commercial on road trucks.

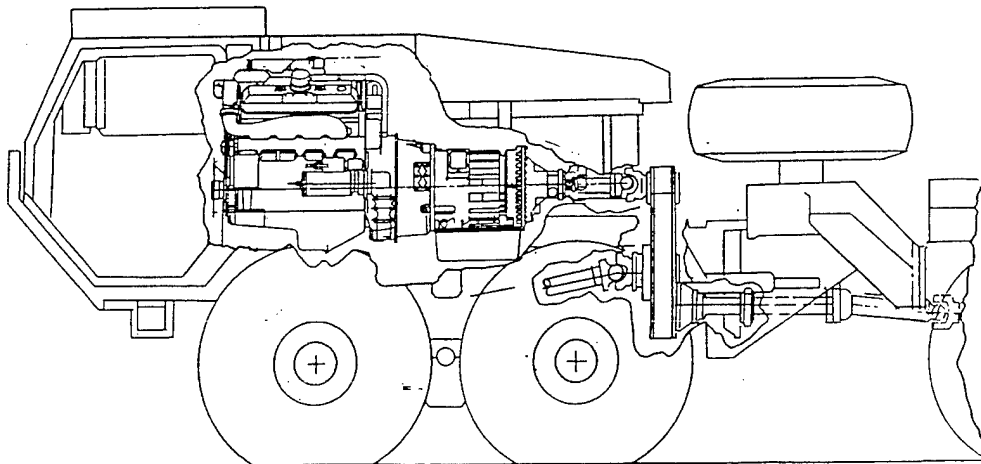

Figure 4.2-1 Existing Front Power Unit

The power plant portion of this study has examined the range of components that will be available for the LVSR program when it begins its production phase, and the performance benefit that is obtained by the application of these components. If additional payload is desired for LVSR how much horsepower is required to maintain the same performance level? As shown in **Table 4.2-1** additional horsepower is required to maintain the same vehicle mobility during off road operations if payload is increased. If additional performance is desired along with additional payload, how much additional horsepower can be added to the LVSR while maintaining the existing FPU structure? This report attempts to establish the practical limit for increasing horsepower on the LVSR, and document its impacts and benefits.

In this study varying horsepower levels are evaluated to determine their effect on LVSR performance and the impact of larger engines on the design of the vehicle. Transmissions were evaluated that can handle increased horsepower and have a wider gear range. More gears and a wider ratio range will allow the vehicle to use a single speed transfer case. Eliminating the need to stop and shift the transfer case range reduces the number of decisions that are required by the vehicle operator and can improve performance in off road terrain. During a typical mission if the terrain varies from marginal to good, the operator will not need to decide whether to stop and shift from low to high range to take advantage of the improved terrain, or stay in low and limit his top speed. The engine and transmission will select the right gear range for the load and speed. The operator will be free to concentrate on driving the vehicle.

New modern engines and transmission used on the LVSR program will use electronic controls that can be integrated into a system of electronic components all communicating on a vehicle wide data bus. Data from sensors already included in these components can be used to tailor maintenance requirements to duty cycle, perform advanced diagnostics, and fault isolation. All of these functions combine to improve reliability and increase cost effectiveness of the LVSR.

Table 4.2-1 Weight and horsepower comparison

	66,000 LB LVS OFF ROAD GVW	77,400 LB LVSR OFF ROAD GVW	86,000 LB LVSR ON ROAD GVW	150,000 LB LVSR GCW
445 HP	13.5 HP/T		10.4 HP/T	5.9 HP/T
500 HP		12.9 HP/T	11.6 HP/T	6.7 HP/T
600 HP		15.5 HP/T	14.0 HP/T	8.0 HP/T

4.2.1 Engines

LVSR vehicles will require new engines as a normal part of the refurbishment or replacement of the vehicle. LVS's engines entering the program will have reached the end of their service life rendering them un-useable for any future phase of LVSR. A simple refurbishment of the existing vehicle returning it to its as new capability will require the existing engine be replaced to provide the service life that would normally be provided by a new vehicle. Any increase in off-road payload will require increased horsepower to maintain the mobility provided by the current LVS's horsepower to weight ratio, or if mobility improvements are desired the installed horsepower will increase even with the same payload capacity. Replacing the LVS engine provides an opportunity to install an engine utilizing the latest electronic control technology that could provide improved performance, fuel economy, reliability, and environmental emissions.

Using the logic stated in the previous paragraph engines with horsepower ratings equal to or larger than the existing 445 hp engine were considered. Length, width, and height of the candidate engines were compared to the space that could be made available in the engine compartment to evaluate if the candidate engines were viable replacements. Some modification of the engine compartment is anticipated to accommodate the new engines, although the modification was limited to engine and cooling system placement, changes in the trucks structural frame or operators cab were not considered.

A cursory overview of engines currently in production and planned for production with major engine manufacturers indicated a goal of 650 horsepower would probably be the practical limit for engines that could be considered. Increasing the installed horsepower will increase the weight of the power plant which can negatively impact performance. Secondary impacts on cooling and other support systems also need to be considered to completely asses the impact of horsepower increases.

4.2.1.1 Engine Specification

To evaluate potential engine candidates we first developed an abbreviated engine specification that described critical engine characteristics that would be required for a LVSR program as shown in **Table 4.2-2**. This specification lists requirements and a listing of engine characteristics that are needed to compare the capabilities of the respective engines. This information can be used to evaluate the impact of each engine on the LVSR engine installation. Using this preliminary specification we gathered data on engines that met the criteria and could be used on the LVSR program. Much of the information on horsepower ratings is projected information, about engines that are expected to be available by year 2002 although are not currently being produced. The horsepower

ratings are based upon using standard diesel fuel and would require de-rating for JP-8, although specific power ratings can be considered for LVS applications. Development in the commercial truck engine market is very dynamic, any projected engine rating today needs to be monitored throughout the life of this program to verify the manufacturers progress toward the projected capabilities. All references to NATO certification and EPA certification are the manufacturer's plans to qualify the engine, not an indication of the engine actually being certified.

Table 4.2-2 Engine Specification

MANUFACTURER	CAT	CAT	CUMMINS	PERKINS	DETROIT DIESEL	DETROIT DIESEL	DETROIT DIESEL	DETROIT DIESEL	MACK
MODEL	C-12	3406	S-600	CV6	8V-92	C-60	C-60	C-60	E9
CONFIGURATION	I-6	I-6	I-6	V-6	V-8	I-6	I-6	I-6	V8
DISPLACEMENT, LITERS	12	14.6	15	13.05	12.1	12.7	14	14	16.4
BASE POWER RATING, HP	375	550	N/A	N/A	400	365	N/A	N/A	400
PROPOSED RATING, HP	500	600	600	600	500	500	600	600	650
% INCREASE	25	9	N/A	N/A	25	37	N/A	N/A	62.5
PEAK TORQUE LB-FT	1650		2060		1475	1650			2050
% RISE									
FUEL CONSUMPTION									
WEIGHT, lbs	1900	2900	2650	2175	2420	2610			2907
LENGTH X WIDTH X HEIGHT, inches	51X36X41	57X38X54	55.6X	32X34X37	44X38X50	57X34X50	57X34X50	57X34X50	46X39X47
CONTROL INTERFACE	J1587							DDEC III,DDEC IV	V-MAC II
NATO CERT.	YES				YES				
EPA CERT.	YES					YES			
ENGINE BRAKE	JACOBS		Y		JACOBS				
BRACING HP			600						420 HP
COLD START									
JP-8	Y	Y	Y	Y	Y	Y	Y	Y	Y

4.2.1.2 Candidate Engines

The majority of engines currently used in commercial trucks in the 400 to 600 horsepower range are in-line six cylinder four stroke engines. The LVS currently employs a Detroit Diesel 8V-92 V-8 displacing 736 cubic inches (12.1 L). This engine is a two stroke diesel and has very good power density when compared to four stroke engines although it traditionally has poorer fuel economy and has proven to be less adaptable to modern emissions requirements. The V configuration also provides a shorter and wider installed volume than an in-line six cylinder engines. Four stroke engines being considered for the LVSR program will not be as power dense but will provide better fuel economy and emissions than the 8V-92T.

The eventual choice for a LVSR engine may depend on engines selected for other vehicles outside the LVSR program. The current 8V-92T engine is used in several other military logistics vehicles that share similar requirements with the LVS. These vehicles were procured in numbers greater than the LVS. The combined effect of the large numbers of similar engines being used reduces the cost of supporting engines used on Marine Corps vehicles. Engines selected for replacement or upgrade on these programs will impact the choice of a LVSR engine.

Three U.S. engine manufactures; Detroit Diesel, Caterpillar, and Cummins, traditionally dominate domestic truck engines in this horsepower class. The current trend for new engines produced by these manufactures for trucks are all in-line six cylinder engines. Their engines are included in this report along with engines from PERKINS and Mack truck. An exhaustive review of all the worlds engine manufactures was not conducted because the goal of this effort was to determine the practical limitation engine sizes applied to LVSR, not actually pick the engine that would be used in the program. At this phase of the LVSR program it is difficult to accurately assess the cost of the candidate engines. This makes it difficult to compare the cost versus benefit provided by each engine. Each manufacturer can only project a cost. An accurate cost is only available once the actual procurement process has began. The engines presented accurately represent the state of the art in truck engines and reflect future trends in engine design and configuration.

Caterpillar Engine Co. has proposed their C-12, an in line six cylinder with 12 Liter displacement. It is currently rated at 450 HP for special purpose use with future ratings up to 500 HP. This engine is not planned to grow past the 500 HP level. If 600 HP is required Cat offer's their 3406 at 14.6 liters. This engine has been used extensively in trucks for many years, it also is an in-line-6 configuration. Both engines have electronically controlled fuel injection for

precise fuel metering and electronic engine control interface with chassis electronics.

Detroit Diesel has proposed their series 60 engine also a in line six cylinder engine. This engine currently displaces 12.7 Liter's and is rated for 500 HP. This engine rating will be increased to 600 HP before the LVSR program is in production. To increase horsepower the engine displacement will be increased to 14 liter's. Detroit diesel has stated there will not be an external package size increase resulting from the displacement increase.

Cummins is proposing a new Signature 600 engine for LVSR. The displacement will approximately 14L with HP rating around 600.

Perkins has proposed a new engine, the CV6. This engine is based on the CV Condor series with existing engines in the V8, V12, V16 configuration. This engine has been used extensively in military applications. The V12 has been selected for the Crusader and the V16 as an alternate engine for AAV. These military engines use the same basic engine components, and could provide a logistics base of support for engines installed in the LVSR. Although this engine has not yet been certified to comply with EPA requirements the manufacture has expressed an intent to do so.

Mack has proposed their E9 engine, a 16.4 L V8. This engine will be certified to 1998 EPA requirements at 650 HP. The engine incorporates an electronic fuel control system. The V8 configuration would minimize the modifications required to install the engine in the existing engine compartment.

4.2.2 Transmissions

The transmission currently used on the LVS is Allison's HT 740, a four speed automatic transmission. Automatic transmissions installed in heavy logistics vehicles reduces the work load on the vehicle operator and have proven to be very successful in this application. This transmission along with a two speed transfer case provides the torque and speed range needed to provide sufficient tractive effort and speed for the various on and off road conditions and the required 60% gradability. To increase horsepower a new transmission will be required as HT 740's are limited to the currently installed 445 HP.

4.2.2.1 Candidate Transmissions

Allison has proposed their HD 4070 transmission. This transmission is the successor to the currently installed HT 740. This transmission will incorporate a seven speed gear box that has a torque converter coupled with a lock-up clutch. The transmission also utilizes electronic controls to control shift points. Different

control algorithms can be installed that allow the transmission to be optimized for performance or fuel economy. Electronic control allows the engine and transmission to be electrically coupled and share information on an electronic information bus. The greatest potential gain to be realized when comparing this transmission to the current LVS transmission is the larger number of gears available. More gears available allow a wider ratio to be covered thereby eliminating the requirement for a two speed transfer case. Since the wider range is built in and always available to the user as opposed to the transfer case that is either in high or low depending on road conditions, more gears provide better acceleration to highway speed when compared to the existing four speed automatic.

Eaton has proposed their CEEMAT transmission a nine speed transmission incorporating a torque converter and automated shifting mechanism. This transmission is essentially a manual transmission with the manual clutch replaced with a torque converter and clutch and an auto shift module replacing the manual shift lever. This transmission has the advantage of providing even more gears and ratio coverage than the Allison. Its disadvantage is that torque must be interrupted for a brief period of time during gear change. This interruption should not be a disadvantage on over the road conditions. The effect of a torque interruption while shifting during off road conditions could have a negative effect on tire slippage.

Twin Disc has proposed their TD61-1175 transmission, a fully automatic transmission with six forward speeds. This transmission incorporates a dropped output that could be used to eliminate the transfer case. A listing of transmission characteristics is shown in **Table 4.2-3**.

Table 4.2-3 Transmission Comparison

MANUFACTURER	ALLISON	EATON	TWIN DISC
Model	HD 4070	CEEMAT	TD61-1175
Weight, lbs	1160	1020	2120
Length, inches	43.5	40.7	40
Ratio Range			
# of Gears	7	8	6
PTO	N	N	N
Retarder	Y	N	Y
Electric Interface	Y	Y	

4.2.3 Performance

To evaluate the effects of the various engines and transmissions, computer predictions of their performance capabilities were evaluated. Listed in **Table 4.2-4** are the grade and speed requirements for LVS. The Mission Needs

Statement (MNS) has a requirement for the LVSR to “maintain a highway speed of 55 mph on grades when fully loaded in a tandem tow” (GCW 150,000 lb). The grade required is not explicitly specified. Typical speed on grade requirements for highway conditions require a 2% grade. LVSR can meet this requirement at GVW with a 500 HP engine. At GCW it cannot be met with a 600 HP engine.

Table 4.2-4 LVS Percent Grade and Speed Requirements (MPH)

% Grade	LVS (MK48/14)	LVS (Mk48/14 w/trailer)
0	45	45
2	26	20
3	26	15
10	NS	0+
30	NS	NS
60	0+*	NS

* Off road GVW

4.2.3.1 Gradability

To assess the impact of horsepower and vehicle weight the following curves demonstrate the performance of the 445, 500 and 600 HP engines in combination with the respective vehicle weights. Gradability is the best measure of a vehicle’s ability to maintain speeds on hilly or mountainous terrain and as a measure of the startability of a vehicle. Startability defines how difficult it will be to start a load from zero velocity and accelerate to road speed. Using an automatic transmission with a torque converter that increases the torque input to the transmission enhances the startability of the vehicle.

Figures 4.2-2 through 4.2-8 show the relative effects of the vehicle weights and engine horsepower levels. All projections are based on paved smooth roads and were generated using a computer simulation of the engine and transmission match. From data generated from previous LVS testing, the data generated by analysis and actual test results are historically within 10%.

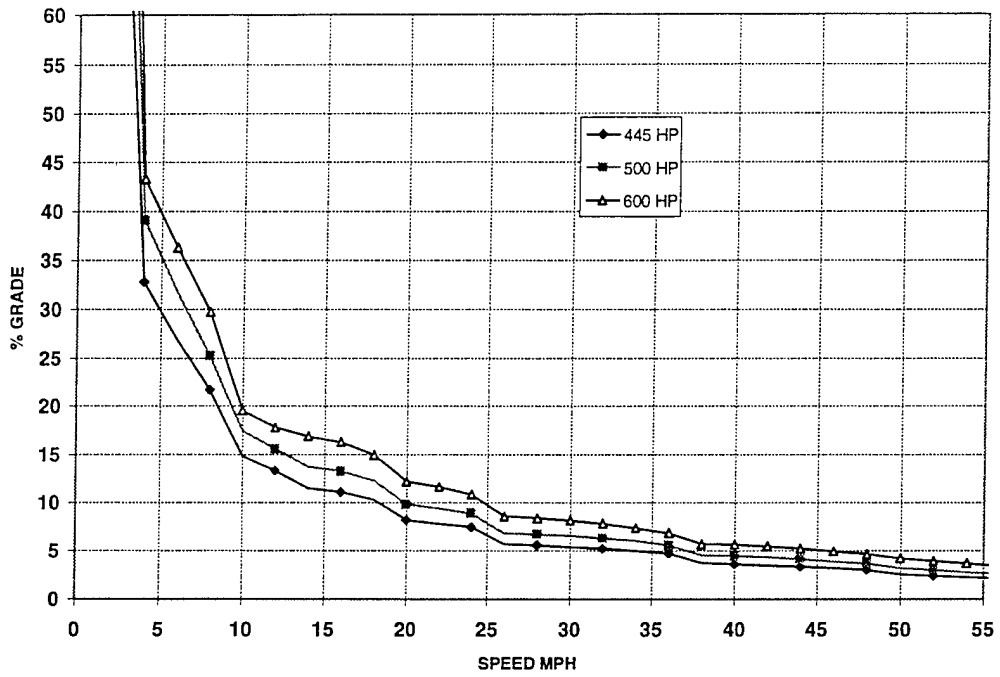

Figure 4.2-2 Grade VS Speed 66,000 LB

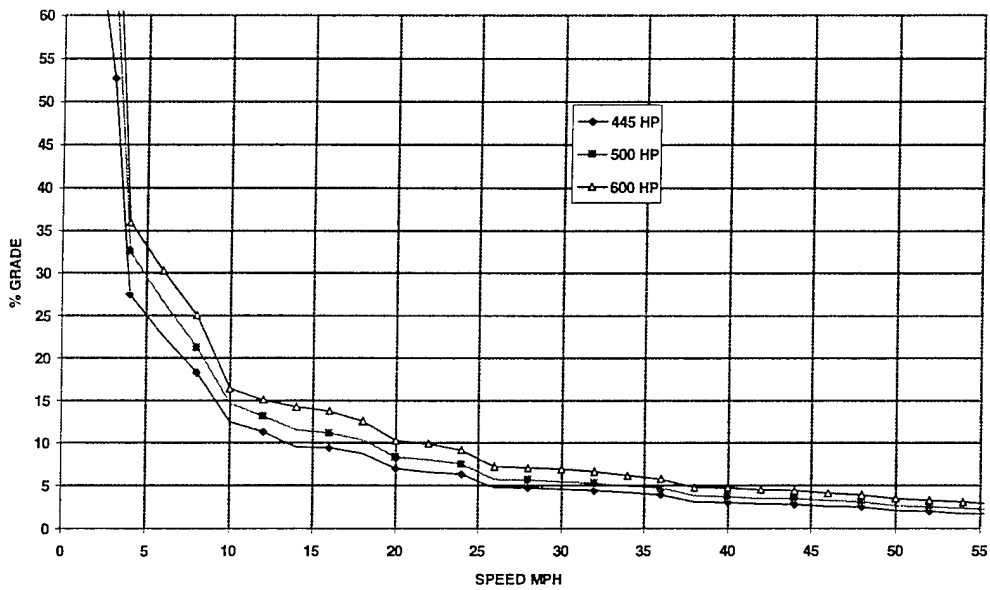

Figure 4.2-3 Grade VS Speed 77,400 LB

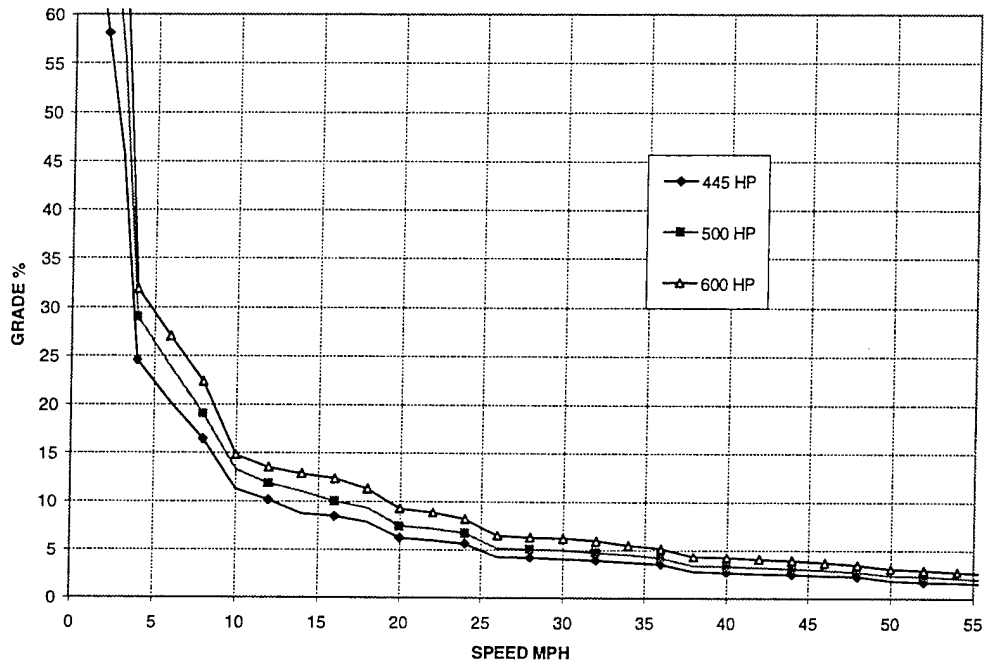

Figure 4.2-4 Grade VS Speed 86,000 LB

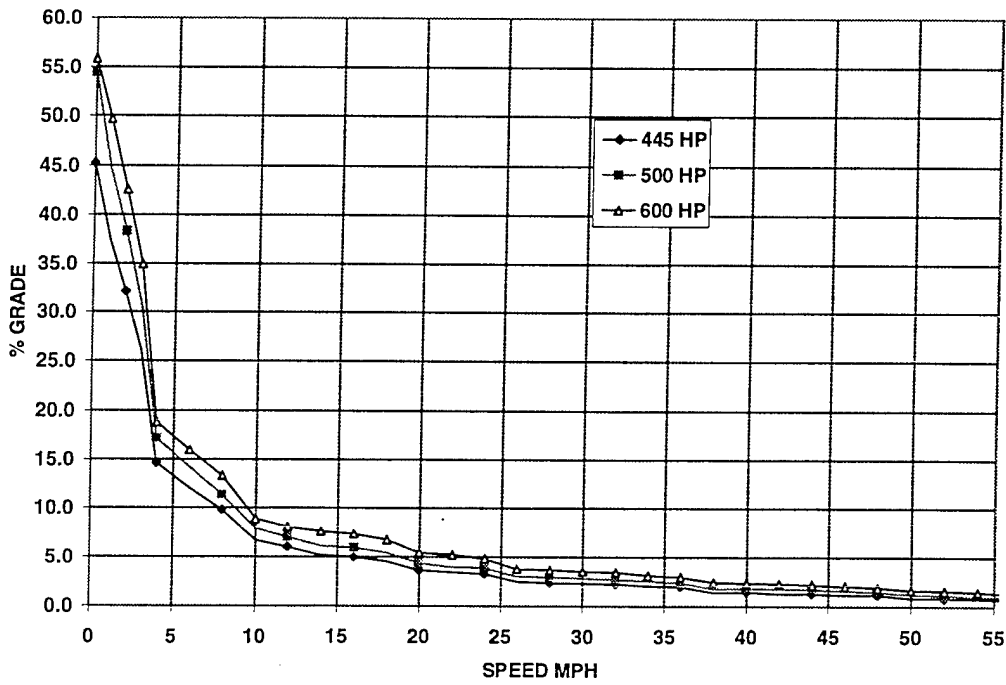

Figure 4.2-5 Grade VS Speed 140,600 LB

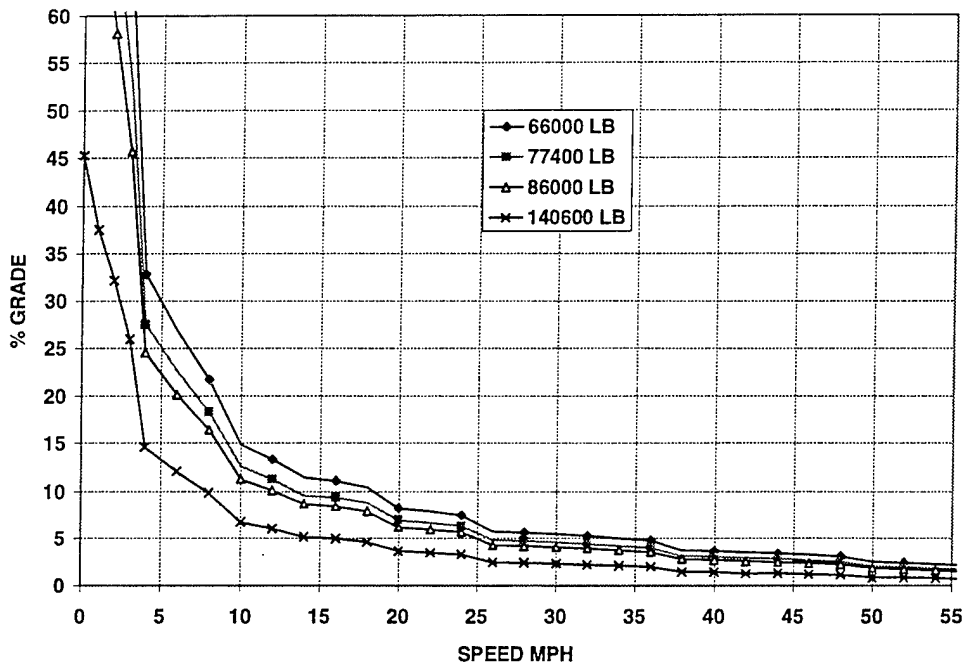

Figure 4.2-6 Grade VS Speed 445 HP

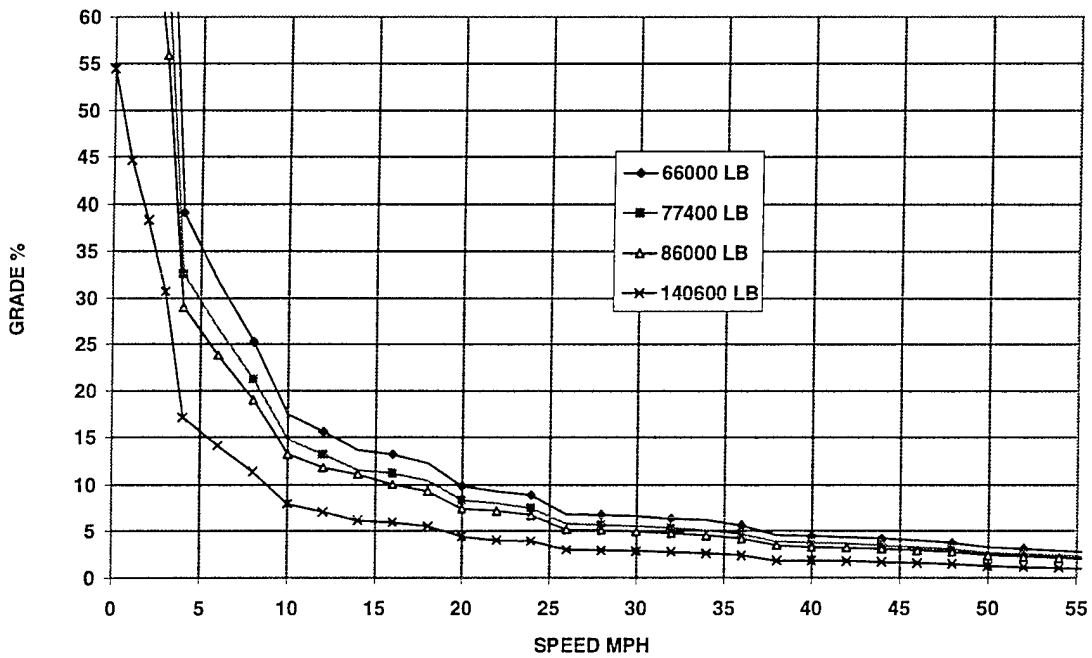

Figure 4.2-7 Grade VS Speed 500 HP

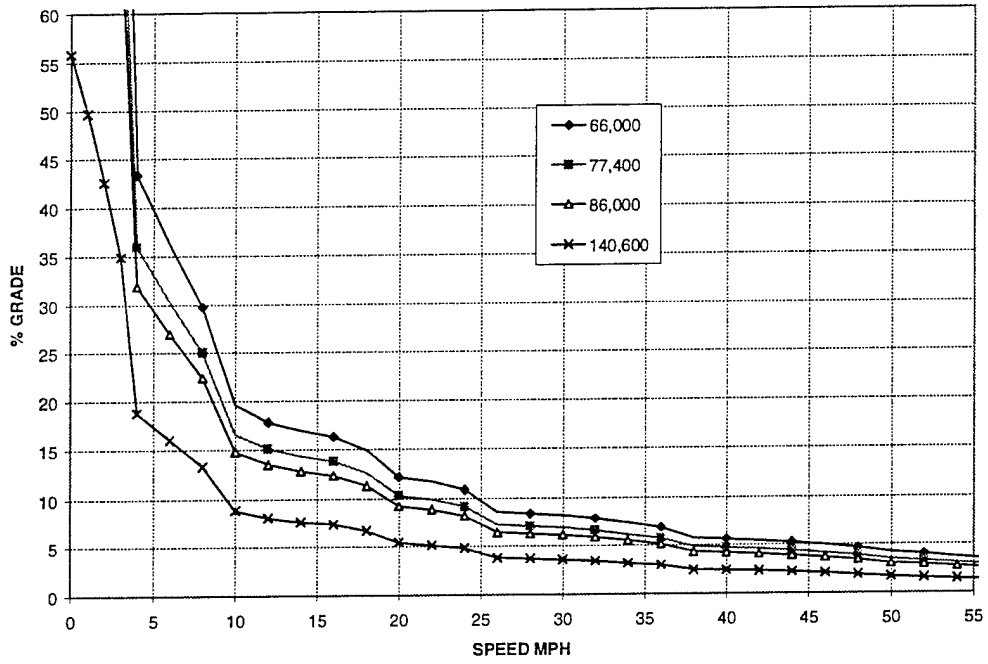

Figure 4.2-8 Grade VS Speed 600 HP

4.2.3.2 Acceleration

Acceleration is influenced by engine size, load, gear ratio range, and the number of gears in a transmission. Automatic transmissions used in this application begin in converter mode, with the torque converter providing torque amplification and a reduced speed ratio. As the vehicle is accelerated the torque converter slippage decreases until the lock up clutch is engaged. With the input to the transmission now locked to the engine output, the engine continues to accelerate until it approaches its governed speed. If continued acceleration is required, the torque converter is unlocked and transmission then shifts to the next higher gear and the process is repeated.

Figures 4.2-9 through 11 show the performance of 445, 500 and 600 HP engines accelerating 77,400, 86,000 and 140,600 LB vehicles to road speed on smooth flat road surfaces. These curves were generated using computer simulations of the engine and transmission matches. Allison's HD 4070 was used for all computer engine matches shown. Comparison between Allison and Eaton performance simulations show performance predictions fall with the 10% analysis to test data error band.

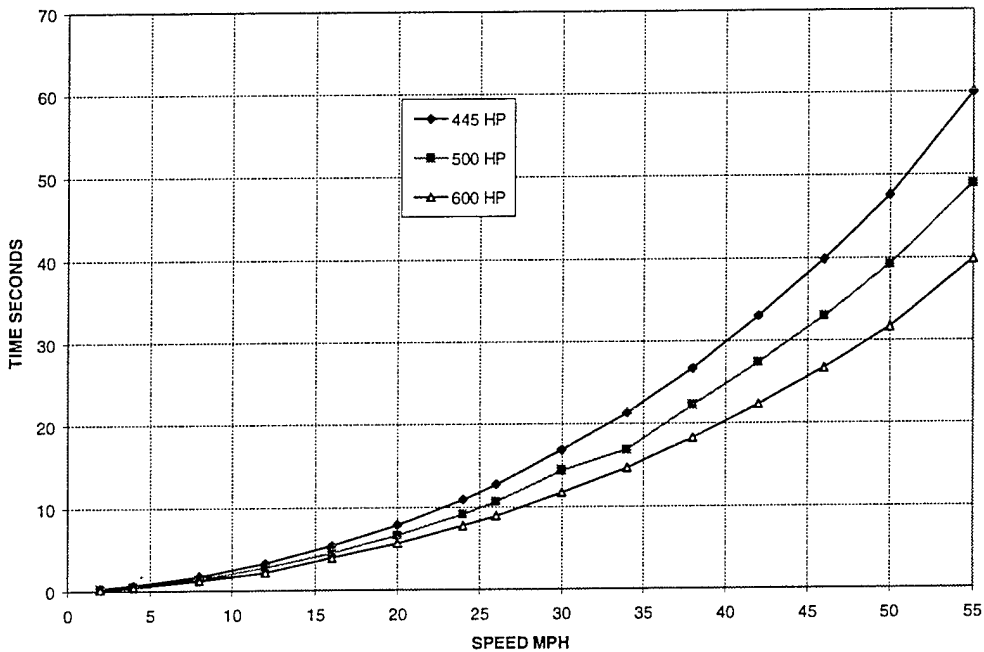

Figure 4.2-9 Time to Speed 77,400 LB

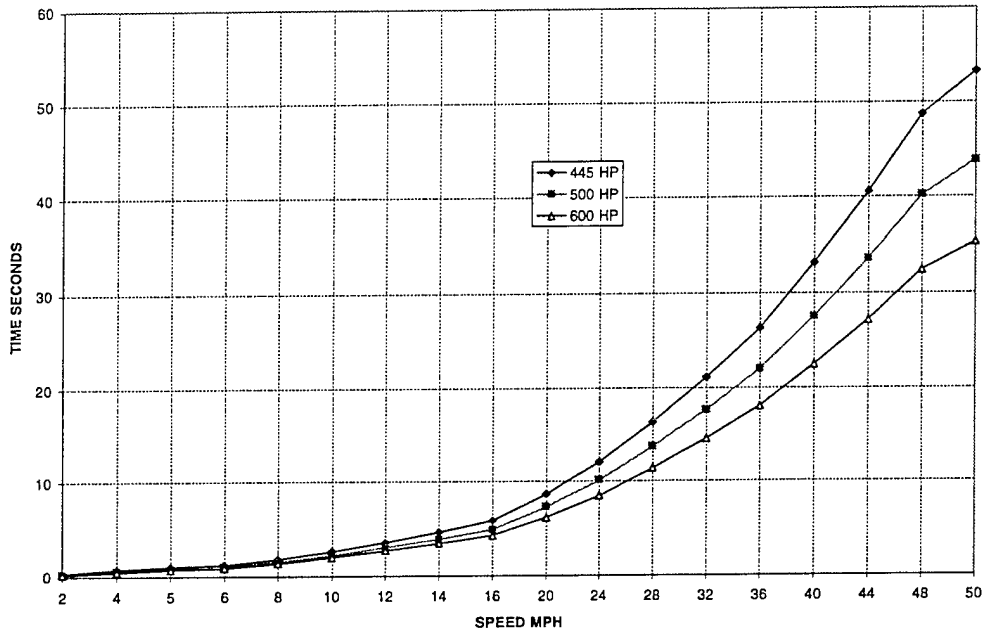

Figure 4.2-10 Time to Speed 86,000 LB

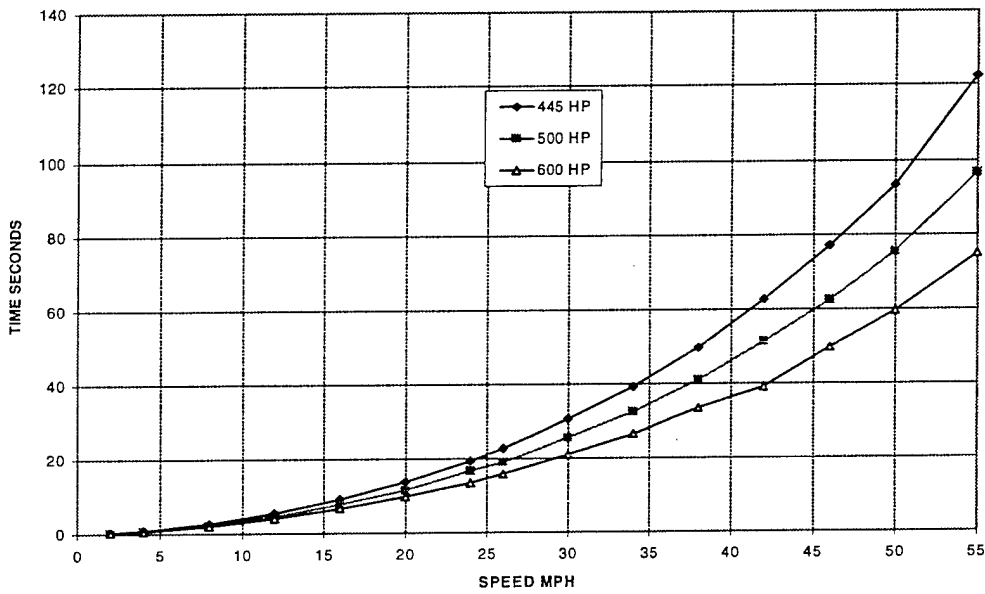

Figure 4.2-11 Time to Speed 140,600 LB

4.2.3.3 Fuel Economy

Four-stroke-cycle engines proposed for LVSR have significantly improved fuel economy when compared to the LVS's 8V-92. Advances in electronic control of the fuel injection process, in combustion, and the improvement inherent in four stroke versus two stroke engines designs will improve fuel consumption. Installing a larger horsepower engine will also increase fuel economy if both vehicle are transporting the same payload. Typically diesel engines are more efficient at less than full horsepower ratings. A larger engine will be operating on a smaller fraction of its full rating, closer to its most efficient load rating, than a smaller engine operating nearer its full horsepower rating. Improved fuel consumption reduces the weight of the fuel required by the vehicle to complete a mission, this reduced fuel load can be used to offset the additional weight of the larger heavier engines. All these comparisons are conducted with the assumption that the payload carried is the same as the engine is changed from LVS to LVSR. At this time highway ratings are not planned to increase for GVW or GCW, only the off road rating is being increased. During highway transportation of payloads this assumption remains valid.

Many of the engines and engine ratings considered for the LVSR upgrade are projections and extensions of current engines or are entirely new engines. Test data is the only way to completely quantify any projected fuel consumption improvement. **Figure 4.2-12** compares a two-stroke-cycle Detroit Diesel 8V-92 and a four-stroke-cycle Series 60 engine both rated at 500 HP. These two engines, both rated at 500 HP, demonstrate the fuel savings that should be typical in the LVSR installation. Fuel consumption for this engine and any of the candidate engines will improve between the completion of this study and the actual fielding of LVSR. A final fuel consumption comparison and analysis will be conducted as part of the final engine selection process by the LVSR contractor.

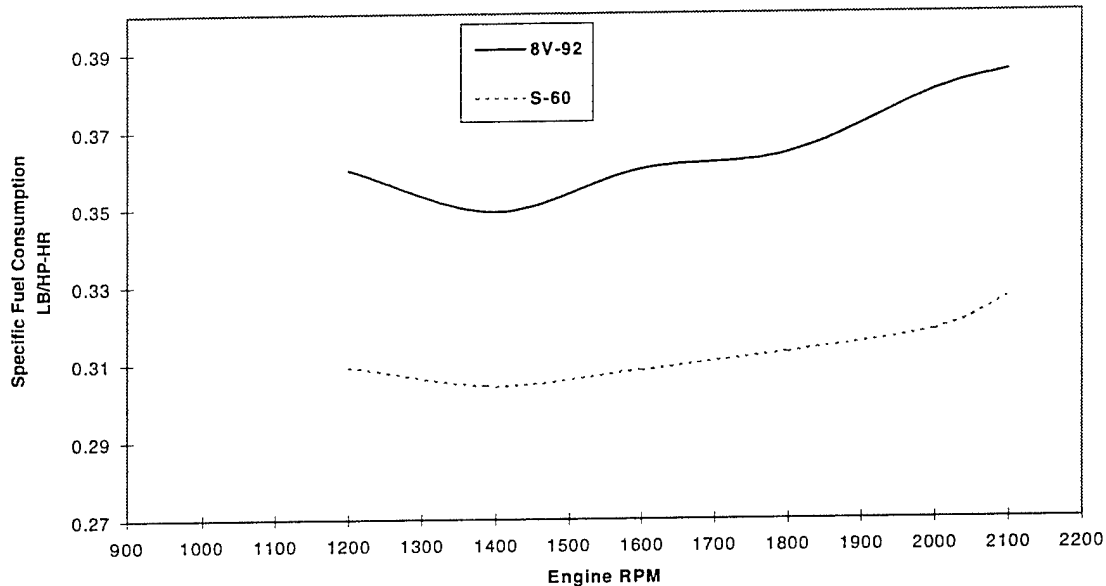

Figure 4.2-12 Fuel Economy Comparison

4.2.4 Installations

As part of the LVSR power plant investigation process a series of engineering sketches have been prepared showing several of the candidate engines and transmissions installed in the LVS engine compartment. The central question to be addressed by this investigation is to determine if 12L to 15L in line six cylinder engines can be installed in LVSR. If this configuration engine can be accommodated, the pool of engines that can be selected is significantly increased. All the engines supplied by Caterpillar, Detroit Diesel and Cummins are in line six cylinders. The current engine and transmission assembly has a propeller shaft between the transmission and the two speed drop box. Sketches show that if the transmission is coupled directly to a thinner drop box there is room to install in-line six cylinder engines in the LVSR engine compartment. The new engines will require new locations for the cooling system, air intake system and exhaust system, complicating the overall installation.

The V6's and V8's will fit into the engine compartment with less vehicle modification. These shorter engines will minimize vehicle modifications and also allow consideration of modifications that would simplify the engine installation. It may be possible to relocate the radiator in front of the engine and install a conventional belt driven fan, reducing the complexity of the vehicle's hydraulic system, and improve the fan drive efficiency. **Figures 4.2-13 through 15** show several of the different engine and transmissions combinations installed in a LVS FPU.

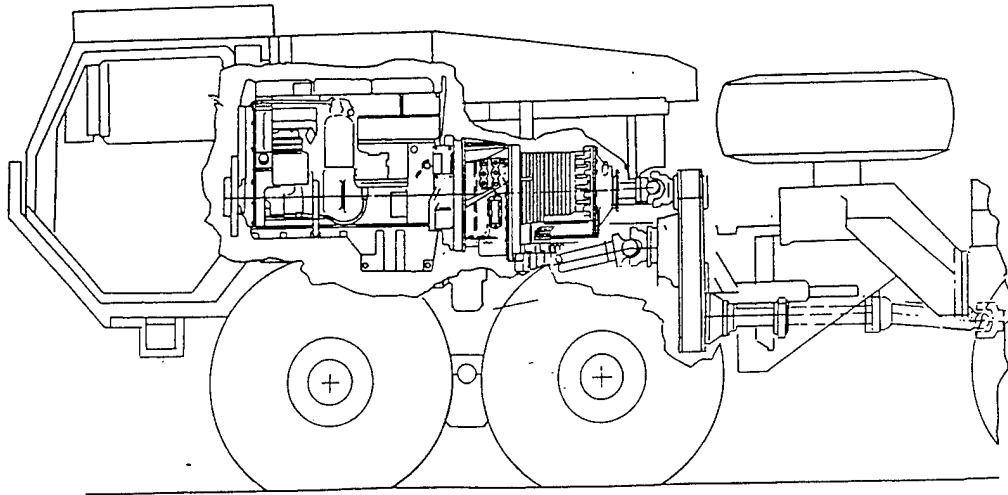

Figure 4.2-13 Caterpillar C12 and Allison 4070P

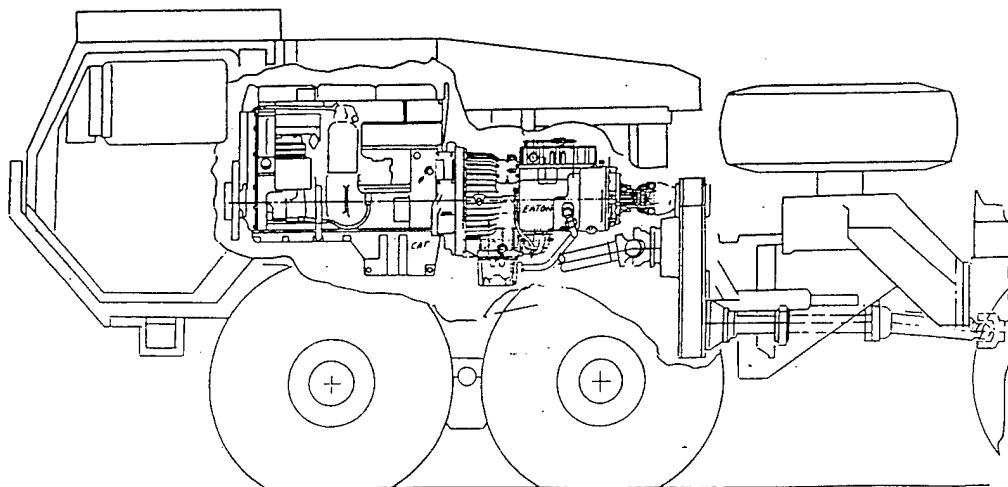

Figure 4.2-14 Caterpillar C12 and Eaton CEEMAT

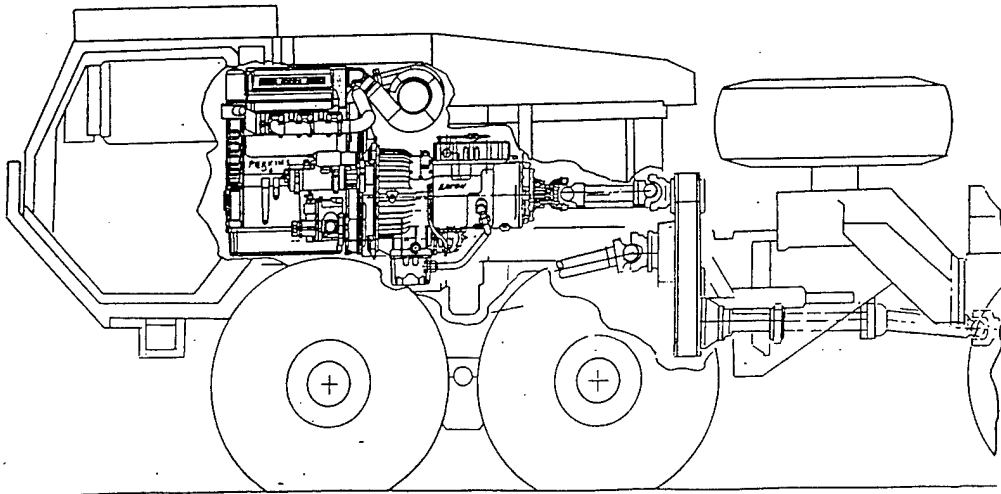

Figure 4.2-15 Perkins CV6 and CEEMAT

4.3 Suspension Upgrade

This section presents a design study of five (5) alternative suspensions systems that could be used on the LVSR. The goal of these investigations is to increase payload and mobility performance. Included in this Section are performance predictions on the trafficability, ride quality and side slope stability of each of the alternatives considered. A comparison to the existing LVS is provided for reference.

4.3.1 Candidate Suspension Configurations

Soft soil trafficability, ride quality and stability are significant factors that affect off-road mobility. The LVS is an 8X8 configuration that employs two (2) Oshkosh bogie type suspensions. These bogies consist of a trunion axle, leaf springs and torque rods. To maintain or improve trafficability with increased payload it will be necessary to increase the number of wheels on the ground to ten (10). To improve ride quality the characteristics of the suspension must be addressed. There are several factors that limit ride quality of the LVS. These factors include; limited jounce travel (3-5 inches), hard travel stops, high unsprung mass at the front axle, no shocks on the rear bogie, stiff springs on the rear bogie, and significant unrestrained side play on both the front and rear bogie. To improve stability the roll stiffness of the RBU suspension should be improved.

During the course of this investigation many commercially available suspension systems were investigated from a variety of suppliers. Many of the available alternatives offer similar capabilities to the existing bogie suspension with the potential for reduced costs or improved reliability. Because the focus of this investigation was improved mobility these "equal capability" suspension were not pursued. Of the alternatives researched, AAI has selected two types of suspensions as the primary alternatives; 1) Independent Suspension Axle System (ISAS) from Meritor Automotive (previously Rockwell Automotive) and 2) Parallelogram Air-Ride AD-246/252 Series from NEWAY Anchorlok International.

The ISAS, designed by Meritor and Timoney Technologies Ltd., is a double A-arm design that can be equipped with either coil, torsion or hydro-pneumatic springs. Because it is an "Axle System" it also includes the differential and brakes with the suspension in one integrated package. Applications of the ISAS include on- and off-road applications, emergency vehicles and tactical military vehicles. Nominal axle ratings of the standard product line ranges from 6.5 to 15 tons. Standard options include; traction control, central tire inflation, and anti-lock braking. Also a variety of differential options are available including 50/50 and 70/30 biasing inter-axle differentials.

The NEWAY AD-246/252 is a heavy duty air suspension systems for on and off-road applications. The AD Series parallelogram design protects critical drive line components and is built to take heavy duty vehicles and provide a soft ride regardless of payload. The ride height control valve permits the air pressure to automatically adjust for the payload condition. The unique torsion link design provides for stable operation on side slopes. Axle selection for the NEWAY suspension system for this study are Meritor Automotive rigid axles similar to those use on the US Army Palletize Load System (PLS).

The five (5) vehicle configurations that were developed for this Suspension Upgrade investigation are:

Suspension Configuration	FPU Suspension	RBU Suspension
ISAS 10X10	ISAS	ISAS
NEWAY 10X10	AD-246	AD-252
Hybrid A	Oshkosh Bogie	ISAS
Hybrid B	Oshkosh Bogie	AD-252
Hybrid C	ISAS	AD-252

Tables 4.3.1-1 through **4.3.1-5** provide mass properties data and axle loading estimates for each of the five alternatives considered. **Figures 4.3.1-1** through **4.3.1-4** show the various alternative suspension configurations.

Table 4.3.1-1 Meritor 10X10 mass properties and axle loading

	No Payload	Payload A	Payload B	Payload C
Vehicle Properties				
Curb Weight, lbs	43,563	43,563	43,563	43,563
Vertical CG, in	43.5	43.5	43.5	43.5
Longitudinal CG, in	137.0	137.0	137.0	137.0
Payload Properties				
Payload, lbs	0	25,000	35,000	45,000
Vertical CG, in *	0	85	97	109
Longitudinal CG, in *	0	261	261	261
GVW, lbs	43,563	68,563	78,563	88,563
Gross Vehicle Properties				
Combind weight, lbs	43,563	68,563	78,563	88,563
Vertical CG, in *	43.50	58.63	67.33	76.78
Longitudinal CG, in *	137.00	182.21	192.24	200.01
Unsprung Properties				
Unsprung Wt., lbs				
Axle 1	2,073	2,073	2,073	2,073
Axle 2	2,073	2,073	2,073	2,073
Axle 3	2,073	2,073	2,073	2,073
Axle 4	2,073	2,073	2,073	2,073
Axle 5	2,073	2,073	2,073	2,073
Axle Locaction from axle 1, in				
Axle 1	0	0	0	0
Axle 2	60	60	60	60
Axle 3	229	229	229	229
Axle 4	289	289	289	289
Axle 5	349	349	349	349
Axle Loads, lbs				
Axle 1	13,050	14,135	14,569	15,003
Axle 2	11,640	13,992	14,933	15,873
Axle 3	7,668	13,589	15,957	18,325
Axle 4	6,258	13,445	16,320	19,196
Axle 5	4,847	13,302	16,684	20,066
Sprung Properties				
Weight, lbs	33,198	58,198	78,563	88,563
Pitch Inertia, lb-sec ² -in	1,654,465	2,553,343	2,895,795	3,248,813
Vertical CG, in *	49.8	64.9	74.0	83.9
Longitudinal CG, in *	121.9	181.6	193.3	201.9
Axle Location from sprung LCG				
Axle 1	121.9	181.6	193.3	201.9
Axle 2	61.9	121.6	133.3	141.9
Axle 3	-107.1	-47.4	-35.7	-27.1
Axle 4	-167.1	-107.4	-95.7	-87.1
Axle 5	-227.1	-167.4	-155.7	-147.1

* Vertical CG measured from ground and Longitudinal CG measured from first axle

Table 4.3.1-2 NEWAY 10X10 mass properties and axle loading

	No Payload	Payload A	Payload B	Payload C
Vehicle Properties				
Curb Weight, lbs	42720	42720	42720	42720
Vertical CG, in	43.39	43.39	43.39	43.39
Longitudinal CG, in	133.10	133.10	133.10	133.10
Payload Properties				
Payload, lbs	0	25000	35000	45000
Vertical CG, in *	0	85	97	109
Longitudinal CG, in *	0	261	261	261
Inertia, lbs-sec ² -in	0	323482	474385	649229
Gross Vehicle Properties				
Combind weight, lbs	42720	67720	77720	87720
Vertical CG, in *	43.39	58.75	67.53	77.05
Longitudinal CG, in *	133.10	180.32	190.70	198.71
Unsprung Properties				
Unsprung Wt., lbs				
Axle 1	3913	3913	3913	3913
Axle 2	3235	3235	3235	3235
Axle 3	3478	3478	3478	3478
Axle 4	3411	3411	3411	3411
Axle 5	3235	3235	3235	3235
Axle Locaction from axle 1, in				
Axle 1	0	0	0	0
Axle 2	60	60	60	60
Axle 3	229	229	229	229
Axle 4	289	289	289	289
Axle 5	349	349	349	349
Axle Loads, lbs				
Axle 1	13129	14480	15021	15561
Axle 2	12451	13802	14343	14883
Axle 3	5817	13249	16222	19195
Axle 4	5750	13182	16155	19128
Axle 5	5574	13006	15979	18952
Sprung Properties				
Weight, lbs	25448	50448	60448	70448
Pitch Inertia, lb-sec ² -in	892284	1,846,537	2,133,999	2,440,146
Vertical CG, in *	57.23	70.99	80.26	90.30
Longitudinal CG, in *	101.41	180.50	193.81	203.35
Axle Location from sprung LCG				
Axle 1	101.41	180.5	193.8	203.4
Axle 2	41.41	120.5	133.8	143.4
Axle 3	-127.59	-48.5	-35.2	-25.6
Axle 4	-187.59	-108.5	-95.2	-85.6
Axle 5	-247.59	-168.5	-155.2	-145.6
Weight on front tandem, lbs	18432	21134	22215	23296
Weight on rear tridem, lbs	7016	29314	38233	47152

* Vertical CG measured from ground and Longitudinal CG measured from first axle

**Table 4.3.1-3 Hybrid A 10X10 mass properties and axle loading
(Oshkosh/Meritor)**

	No Payload	Payload A	Payload B	Payload C
Vehicle Properties				
Curb Weight, lbs	42863	42863	42863	42863
Vertical CG, in	42.9	42.9	42.9	42.9
Longitudinal CG, in	132.9	132.9	132.9	132.9
Payload Properties				
Payload, lbs	0	25000	35000	45000
Vertical CG, in *	0	85	97	109
Longitudinal CG, in *	0	261	261	261
Inertia, lbs-sec ² -in	0	323482	474385	649229
Gross Vehicle Properties				
Combind weight, lbs	42863	67863	77863	87863
Vertical CG, in *	42.90	58.41	67.22	76.75
Longitudinal CG, in *	132.90	180.09	190.48	198.51
Unsprung Properties				
Unsprung Wt., lbs				
Axle 1	4208	4208	4208	4208
Axle 2	3308	3308	3308	3308
Axle 3	2073	2073	2073	2073
Axle 4	2073	2073	2073	2073
Axle 5	2073	2073	2073	2073
Axle Locaction from axle 1, in				
Axle 1	0	0	0	0
Axle 2	60	60	60	60
Axle 3	229	229	229	229
Axle 4	289	289	289	289
Axle 5	349	349	349	349
Axle Loads, lbs				
Axle 1	12728	14379	15039	15700
Axle 2	11828	13479	14139	14800
Axle 3	7143	13082	15458	17834
Axle 4	6102	13335	16228	19121
Axle 5	5062	13588	16998	20409
Sprung Properties				
Weight, lbs	29128	54128	64128	74128
Pitch Inertia, lb-sec ² -in	1,357,589	2,316,708	2,629,988	2,960,095
Vertical CG, in *	49.8	66.06	75.56	85.74
Longitudinal CG, in *	133.2	192.23	202.95	210.78
Axle Location from sprung LCG				
Axle 1	133.2	192.2	203.0	210.8
Axle 2	73.2	132.2	143.0	150.8
Axle 3	-95.8	-36.8	-26.0	-18.2
Axle 4	-155.8	-96.8	-86.0	-78.2
Axle 5	-215.8	-156.8	-146.0	-138.2

* Vertical CG measured from ground and Longitudinal CG measured from first axle

Table 4.3.1-4 Hybrid B 10X10 mass properties and axle loading
(Oshkosh/NEWAY)

	No Payload	Payload A	Payload B	Payload C
Vehicle Properties				
Curb Weight, lbs	43288	43288	43288	43288
Vertical CG, in	43.29	43.29	43.29	43.29
Longitudinal CG, in	133.5	133.5	133.5	133.5
Payload Properties				
Payload, lbs	0	25000	35000	45000
Vertical CG, in *	0	85	97	109
Longitudinal CG, in *	0	261	261	261
Inertia, lbs-sec ² -in	0	323482	474385	649229
Gross Vehicle Properties				
Combind weight, lbs	43288	68288	78288	88288
Vertical CG, in *	43.29	58.56	67.30	76.78
Longitudinal CG, in *	133.50	180.18	190.50	198.49
Unsprung Properties				
Unsprung Wt., lbs				
Axle 1	4208	4208	4208	4208
Axle 2	3308	3308	3308	3308
Axle 3	3478	3478	3478	3478
Axle 4	3411	3411	3411	3411
Axle 5	3235	3235	3235	3235
Axle Locaction from axle 1, in				
Axle 1	0	0	0	0
Axle 2	60	60	60	60
Axle 3	229	229	229	229
Axle 4	289	289	289	289
Axle 5	349	349	349	349
Axle Loads, lbs				
Axle 1	13294	14646	15186	15727
Axle 2	12394	13746	14286	14827
Axle 3	5970	13402	16375	19348
Axle 4	5903	13335	16308	19281
Axle 5	5727	13159	16132	19105
Sprung Properties				
Weight, lbs	25648	50648	60648	70648
Pitch Inertia, lb-sec ² -in	1010762	1,954,493	2,244,196	2,552,274
Vertical CG, in *	53.67	69.13	78.68	88.91
Longitudinal CG, in *	105.49	182.25	195.24	204.54
Axle Location from sprung LCG				
Axle 1	105.49	182.3	195.2	204.5
Axle 2	45.49	122.3	135.2	144.5
Axle 3	-123.51	-46.7	-33.8	-24.5
Axle 4	-183.51	-106.7	-93.8	-84.5
Axle 5	-243.51	-166.7	-153.8	-144.5
Weight on front tandem, lbs	18172	20875	21956	23037
Weight on rear tridem, lbs	7476	29773	38692	47611

* Vertical CG measured from ground and Longitudinal CG measured from first axle

Table 4.3.1-5 Hybrid C 10X10 mass properties and axle loading
(Meritor/NEWAY)

	No Payload	Payload A	Payload B	Payload C
Vehicle Properties				
Curb Weight, lbs	43193	43193	43193	43193
Vertical CG, in	44.03	44.03	44.03	44.03
Longitudinal CG, in	131.80	131.80	131.80	131.80
Payload Properties				
Payload, lbs	0	25000	35000	45000
Vertical CG, in *	0	85	97	109
Longitudinal CG, in *	0	261	261	261
Inertia, lbs-sec ² -in	0	323482	474385	649229
Gross Vehicle Properties				
Combind weight, lbs	43193	68193	78193	88193
Vertical CG, in *	44.03	59.05	67.74	77.18
Longitudinal CG, in *	131.80	179.17	189.63	197.72
Unsprung Properties				
Unsprung Wt., lbs				
Axle 1	2073	2073	2073	2073
Axle 2	2073	2073	2073	2073
Axle 3	3478	3478	3478	3478
Axle 4	3411	3411	3411	3411
Axle 5	3235	3235	3235	3235
Axle Location from axle 1, in				
Axle 1	0	0	0	0
Axle 2	60	60	60	60
Axle 3	229	229	229	229
Axle 4	289	289	289	289
Axle 5	349	349	349	349
Axle Loads, lbs				
Axle 1	13045	14396	14936	15477
Axle 2	13045	14396	14936	15477
Axle 3	5805	13237	16210	19183
Axle 4	5738	13170	16143	19116
Axle 5	5562	12994	15967	18940
Sprung Properties				
Weight, lbs	28923	53923	63923	73923
Pitch Inertia, lb-sec ² -in	969298	1,996,896	2,299,235	2,620,531
Vertical CG, in *	53.84	68.28	77.47	87.42
Longitudinal CG, in *	92.50	170.62	184.76	195.07
Axle Location from sprung LCG				
Axle 1	92.50	170.6	184.8	195.1
Axle 2	32.50	110.6	124.8	135.1
Axle 3	-136.50	-58.4	-44.2	-33.9
Axle 4	-196.50	-118.4	-104.2	-93.9
Axle 5	-256.50	-178.4	-164.2	-153.9
Weight on front tandem, lbs	21943	24646	25727	26808
Weight on rear tridem, lbs	6980	29277	38196	47115

* Vertical CG measured from ground and Longitudinal CG measured from first axle

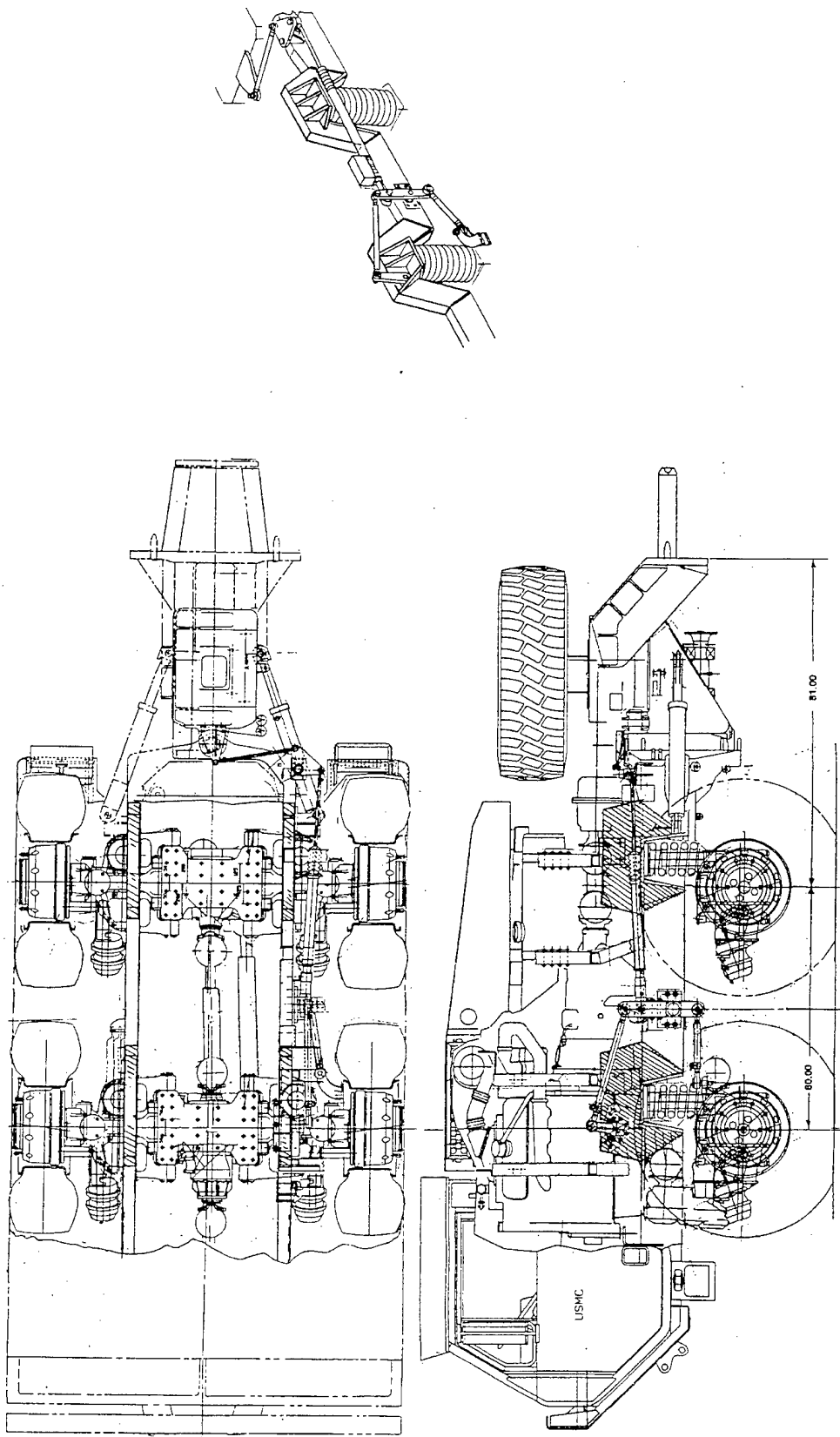

Figure 4.3.1-1 FPU with Meritor ISAS

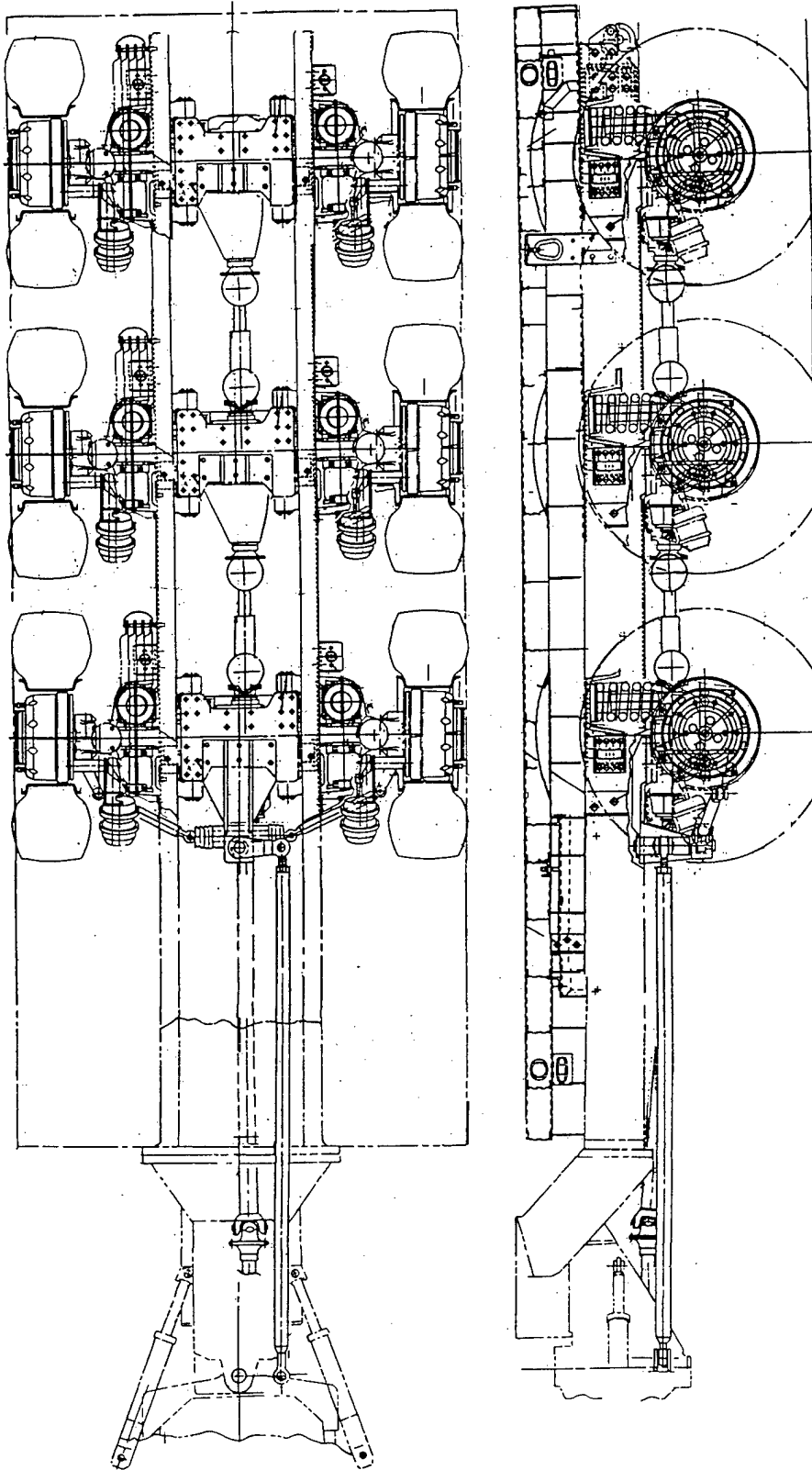

Figure 4.3.1-2 RBU with Meritor ISAS

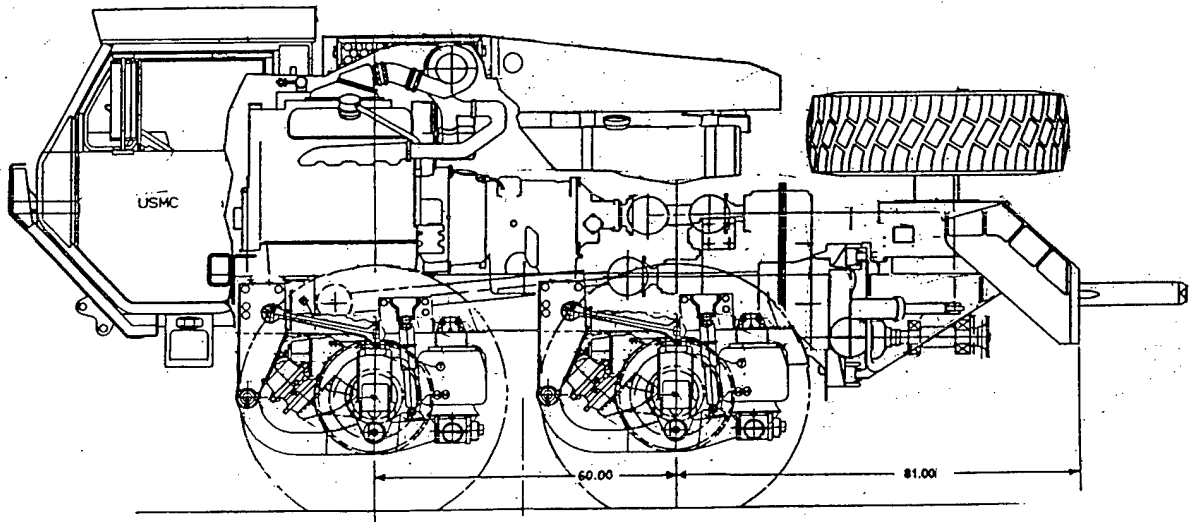
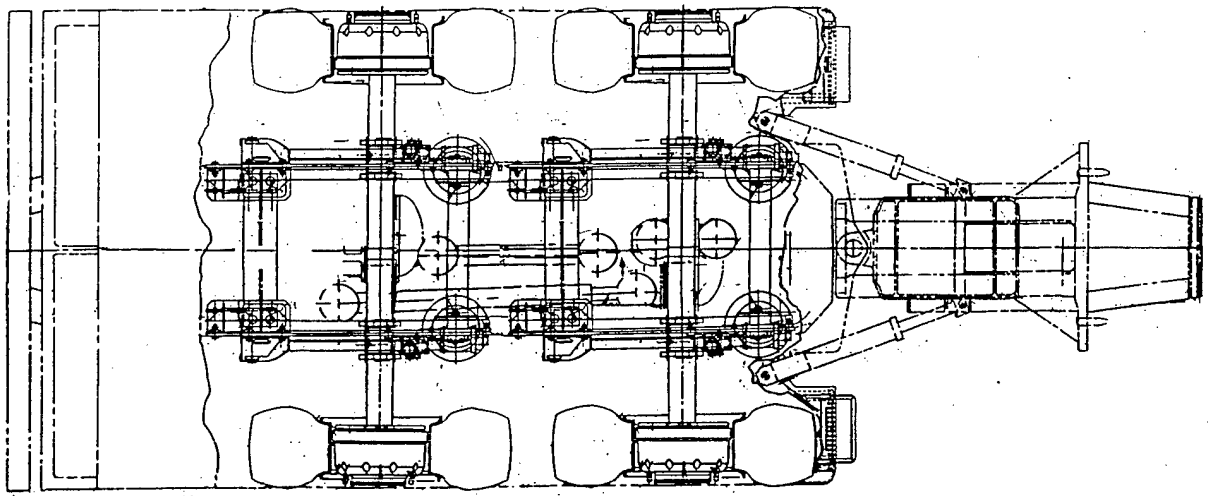

Figure 4.3.1-3 FPU with NEWAY AD-246 Suspension

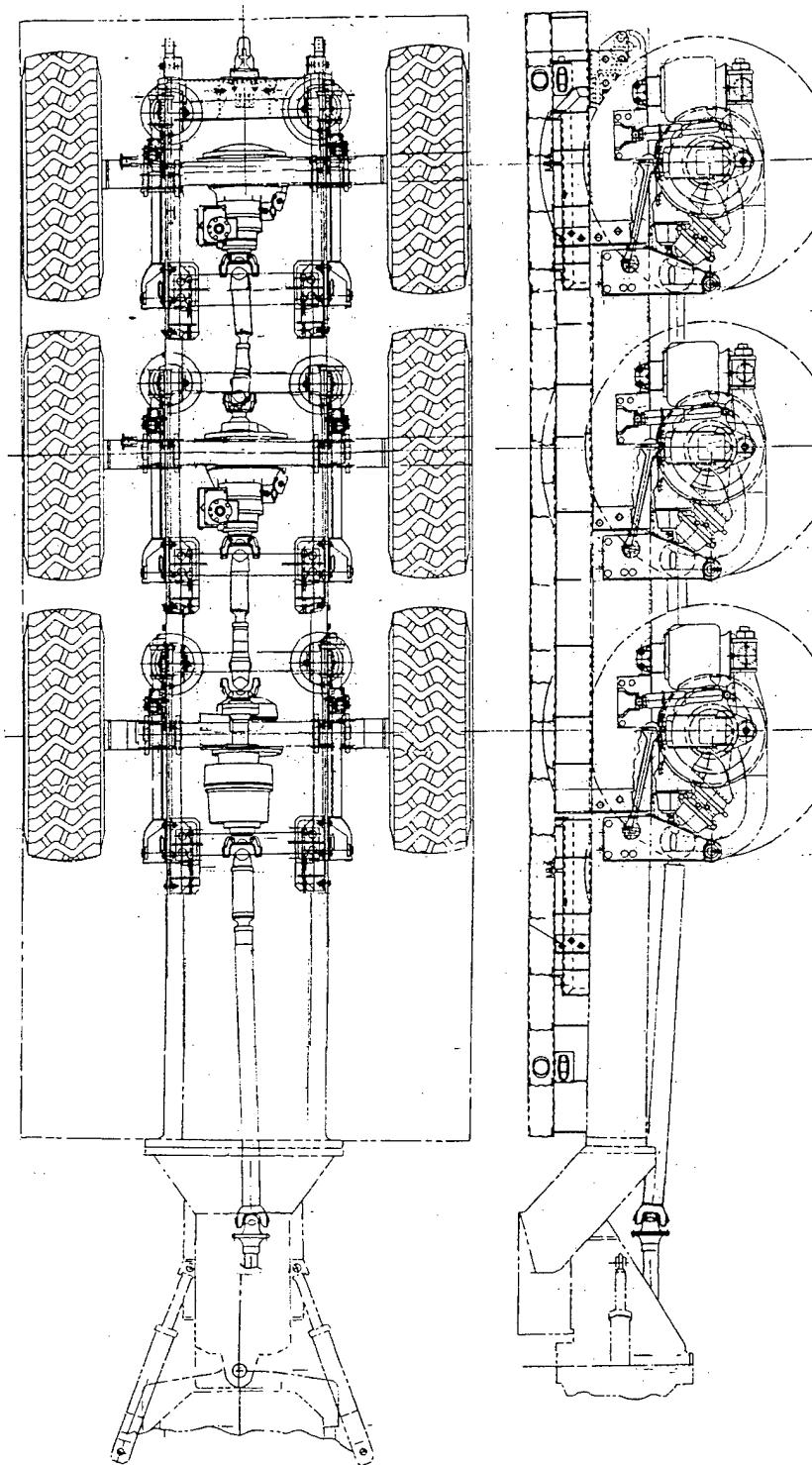

Figure 4.3.1-4 RBU with NEWAY AD-252 Suspension

4.3.2 Trafficability

Vehicle trafficability was calculated for each additional candidate vehicle, as described in **Section 4.1.2**. Axle loads, VCI_1 , and improvements over the baseline LVS (Mk48/14) are given in the following tables. **Table 4.3.2-1a** shows the vehicle performance predictions for the LVSR candidate concept vehicle incorporating the Meritor independent suspension and drivetrain. **Table 4.3.2-1b** shows the vehicle performance predictions for the LVSR with the NEWAY Air Ride suspension. **Table 4.3.2-1c** shows the vehicle performance predictions with the Meritor independent suspension and drivetrain incorporated into the RBU.

Table 4.3.2-1a

MERITOR INDEPENDENT SUSPENSION				
AXLE	EMPTY	12.5 T	17.5 T	22.5 T
1	13,050	14,135	14,569	15,003
2	11,640	13,992	14,933	15,873
3	7668	13,589	15,957	18,325
4	6258	13,445	16,320	19,196
5	4847	13,302	16,684	20,066
VCI_1	16.27	17.43	20.98	27.53
% Improvement	2.28	27.65	38.49	34.15

Table 4.3.2-1b

NEWAY AIR RIDE SUSPENSION				
AXLE	EMPTY	12.5 T	17.5 T	22.5 T
1	13,129	14,480	15,021	15,561
2	12,451	13,802	14,343	14,883
3	5817	13,249	16,222	19,185
4	5750	13,182	16,155	19,128
5	5574	13,006	15,979	18,952
VCI_1	16.33	17.88	20.20	25.73
% Improvement	1.92	25.78	40.78	38.46

Table 4.3.2-1c

HYBRID A				
AXLE	EMPTY	12.5 T	17.5 T	22.5 T
1	12,728	14,379	15,039	15,700
2	11,828	13,479	14,139	14,800
3	7143	13,082	15,458	17,834
4	6102	13,335	16,228	19,121
5	5062	13,588	16,998	20,409
VCI_1	16.03	17.75	21.45	28.48
% Improvement	3.72	26.32	37.12	31.88

Table 4.3.2-1d				
HYBRID B				
AXLE	EMPTY	12.5 T	17.5 T	22.5 T
1	13,294	14,646	15,186	15,727
2	12,394	13,746	14,286	14,827
3	5970	13,402	16,375	19,348
4	5903	13,335	16,308	19,281
5	5727	13,159	16,132	19,105
VCI ₁	16.45	18.10	20.52	26.00
% Improvement	1.20	24.87	39.84	37.81

Table 4.3.2-1e				
HYBRID C				
AXLE	EMPTY	12.5 T	17.5 T	22.5 T
1	13,405	14,396	14,936	15,477
2	13,405	14,396	14,936	15,477
3	5805	13,237	16,210	19,183
4	5738	13,170	16,143	19,116
5	5562	12,994	15,967	18,940
VCI ₁	16.27	17.77	20.28	25.71
% Improvement	2.28	26.23	40.55	38.51

Table 4.3.2-1d shows the vehicle performance predictions for the LVSR candidate concept vehicle with the NEWAY Air Ride suspension incorporated into the RBU. **Table 4.3.2-1e** shows the vehicle performance predictions for the LVSR candidate concept vehicle with the Meritor independent suspension on the FPU and the NEWAY air ride suspension on the RBU.

Figure 4.3.2-1a shows the trafficability performance predictions for the LVSR candidate concept vehicles with the Meritor and NEWAY suspensions.

Figure 4.3.2-1b shows the predicted performance of these two vehicle designs as a percentage improvement over the baseline LVS (Mk48/14) vehicle. **Figure 4.3.2-2a** shows the predicted trafficability performance of the two hybrid concept vehicles with the Meritor and NEWAY suspensions on the RBUs. **Figure 4.3.2-2b** shows the predicted performance of these two vehicles as a percentage improvement over the baseline LVS (Mk48/14) vehicle.

VEHICLE TRAFFICABILITY

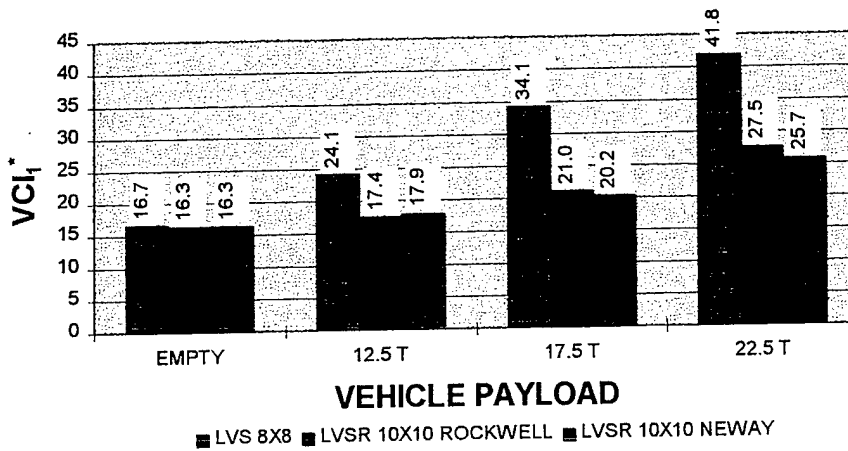

Figure 4.3.2-1a- Vehicle Trafficability

All of these LVSR candidate concept vehicle designs show improvement over the baseline LVS (Mk48/14) for trafficability performance. The configurations containing the NEWAY air ride suspension show the greatest promise of improved off-road performance. These include hybrid configurations B and C as well as the all NEWAY configuration.

The baseline vehicle possesses a VCI_1^* of 24.09 with a 12.5 ton cargo payload, where the LVSR 10X10 with NEWAY air ride suspension possesses a VCI_1^* of 25.73 with 22.5 tons of cargo (Hybrid B possesses a VCI_1^* of 26.0 and Hybrid C possesses a VCI_1^* of 25.7, both at 22.5 ton payload). This translates to comparable off-road performance with an additional 10 tons of cargo capacity.

VEHICLE TRAFFICABILITY IMPROVEMENT

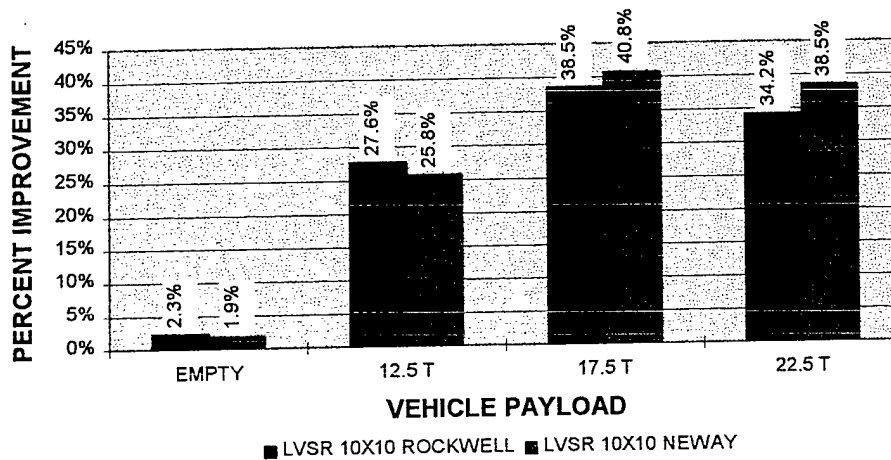

Figure 4.3.2-1b - Vehicle Trafficability Improvement

VEHICLE TRAFFICABILITY

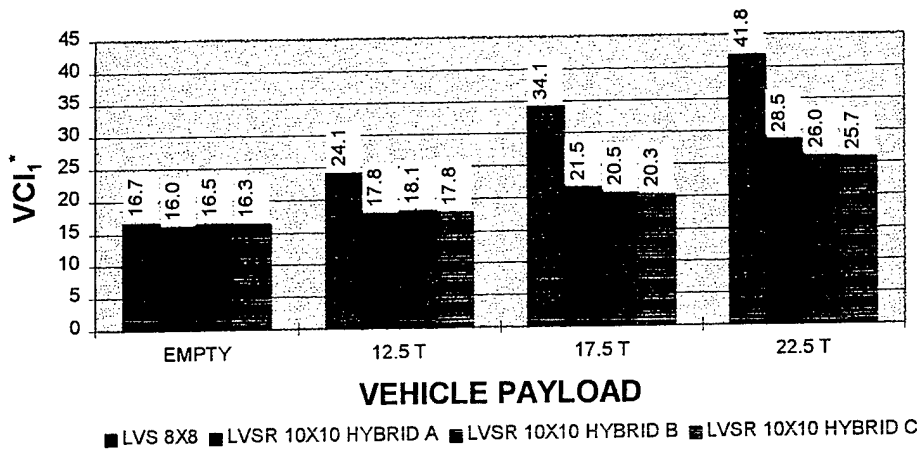

Figure 4.3.2-2a - Hybrid Vehicle Trafficability

VEHICLE TRAFFICABILITY IMPROVEMENT

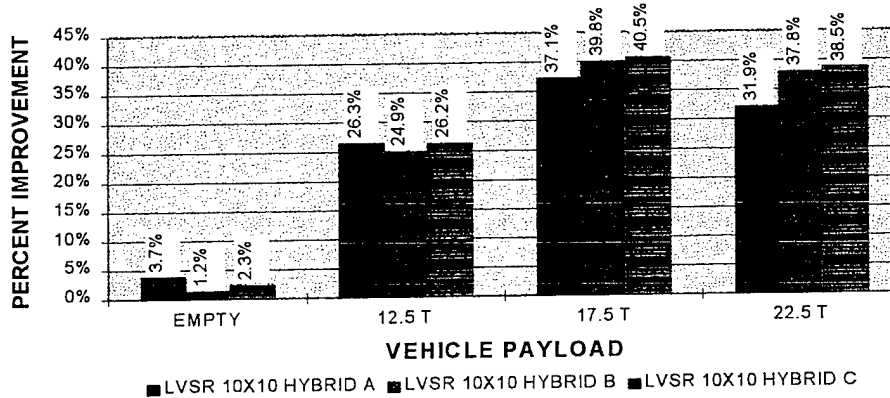

Figure 4.3.2-2b - Hybrid Vehicle Trafficability Improvement

4.3.3 Ride Performance

Ride performance predictions for each additional candidate vehicle were calculated as described in **Section 4.1.3**. Ride quality will again be compared to those predictions generated for the baseline LVS (Mk48/14) vehicle. Ride performance predictions for the LVS candidate concept vehicles are given in the following tables.

Table 4.3.3-1 lists the performance predictions for the Meritor independent suspension and drivetrain and the NEWAY air ride suspension. **Table 4.3.3-2** lists the predicted performance for the two hybrid vehicle designs, which have suspension improvements incorporated into their RBUs.

Table 4.3.3-1 - Ride Performance Predictions

Terrain File	RMS (in)	Meritor				NEWAY			
		EMPTY		LOADED		EMPTY		LOADED	
		V_{6W}	+						
CHV06	0.19	>55	>239	>55	>29	>55	>239	>55	>29
CHV01	0.34	>55	>283	>55	>32	46.75	226	44.50	6
APG37	0.66	31.00	177	29.83	49	30.13	169	31.47	57
FTK34	0.86	33.05	451	32.12	124	18.20	203	16.00	11
APG09	1.01	39.80	765	40.65	203	13.68	197	15.90	19
LET05R	1.20	24.34	441	24.47	84	15.41	242	14.82	11
YPG04	1.81	12.82	123	12.34	75	12.01	109	12.08	71
APG29	2.17	15.90	279	14.35	168	13.13	213	13.13	145
LET07L	3.27	10.68	154	10.01	122	5.80	38	5.90	31
LET07R	3.49	10.33	152	10.01	133	5.37	31	4.90	14
LET16	4.00	9.94	145	9.02	114	5.05	25	4.45	5

Table 4.3.3-2a - Ride Performance Predictions

Terrain File	RMS (in)	HYBRID A				HYBRID B			
		EMPTY		LOADED		EMPTY		LOADED	
		V_{6W}	+	V_{6W}	+	V_{6W}	+	V_{6W}	+
CHV06	0.19	>55	>239	>55	>29	>55	>239	>55	>29
CHV01	0.34	46.15	222	43.97	5	45.32	216	44.55	7
APG37	0.66	22.82	104	27.54	38	22.82	104	22.75	14
FTK34	0.86	17.13	186	16.21	13	17.10	185	16.76	17
APG09	1.01	14.18	208	14.49	8	14.37	212	15.10	13
LET05R	1.20	13.35	197	14.49	9	13.97	210	14.30	8
YPG04	1.81	12.03	109	12.13	72	12.06	110	12.10	72
APG29	2.17	12.97	209	12.50	133	12.52	198	12.68	137
LET07L	3.27	5.48	30	5.53	23	5.70	36	5.21	16
LET07R	3.49	5.29	29	5.00	16	5.30	29	5.01	17
LET16	4.00	5.14	27	4.52	7	5.10	26	4.41	5

Table 4.3.3-2b - Ride Performance Predictions

Terrain File	RMS (in)	HYBRID C			
		EMPTY		LOADED	
		V_{6W}	+	V_{6W}	+
CHV06	0.19	>55	>239	>55	>29
CHV01	0.34	>55	>283	>55	>32
APG37	0.66	30.48	172	32.50	63
FTK34	0.86	32.20	437	28.03	95
APG09	1.01	19.00	313	18.30	37
LET05R	1.20	23.50	422	18.37	38
YPG04	1.81	12.77	122	11.82	68
APG29	2.17	15.22	262	14.02	162
LET07L	3.27	10.33	146	10.02	123
LET07R	3.49	9.88	141	8.93	108
LET16	4.00	8.80	117	5.68	35

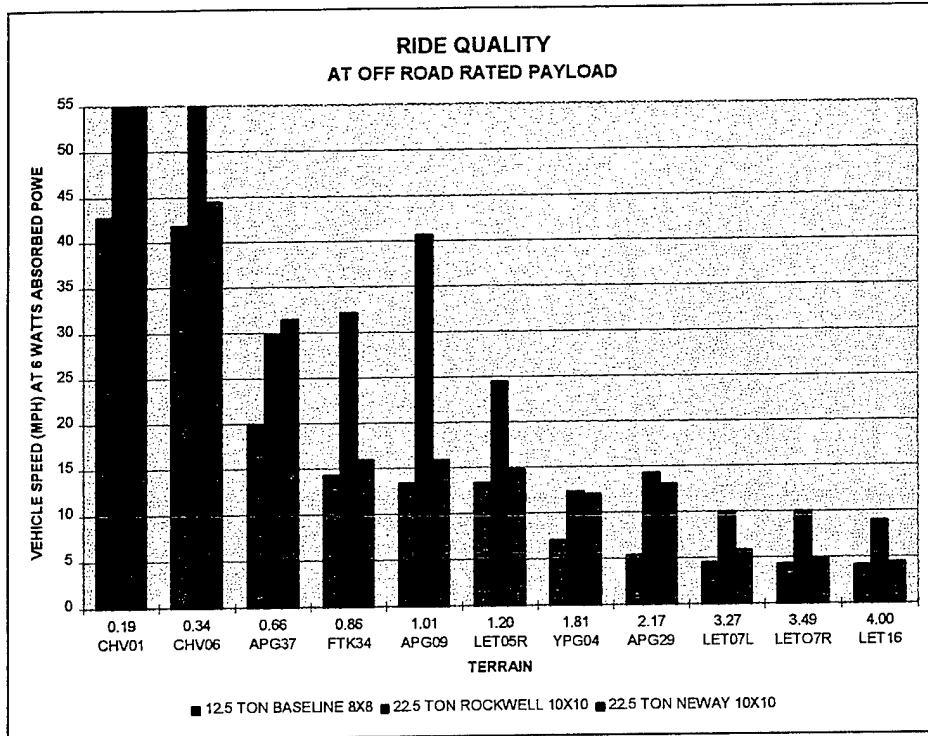

Figure 4.3.3-1a - Ride Quality Comparison (Rated Payload)

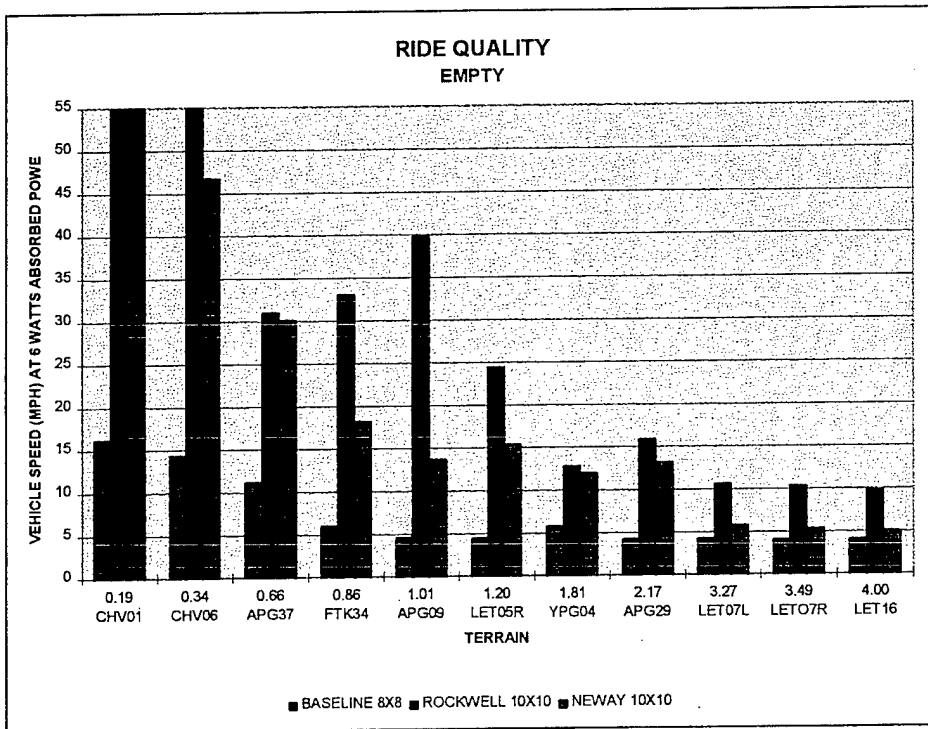

Figure 4.3.3-1b - Ride Quality Comparison (Empty)

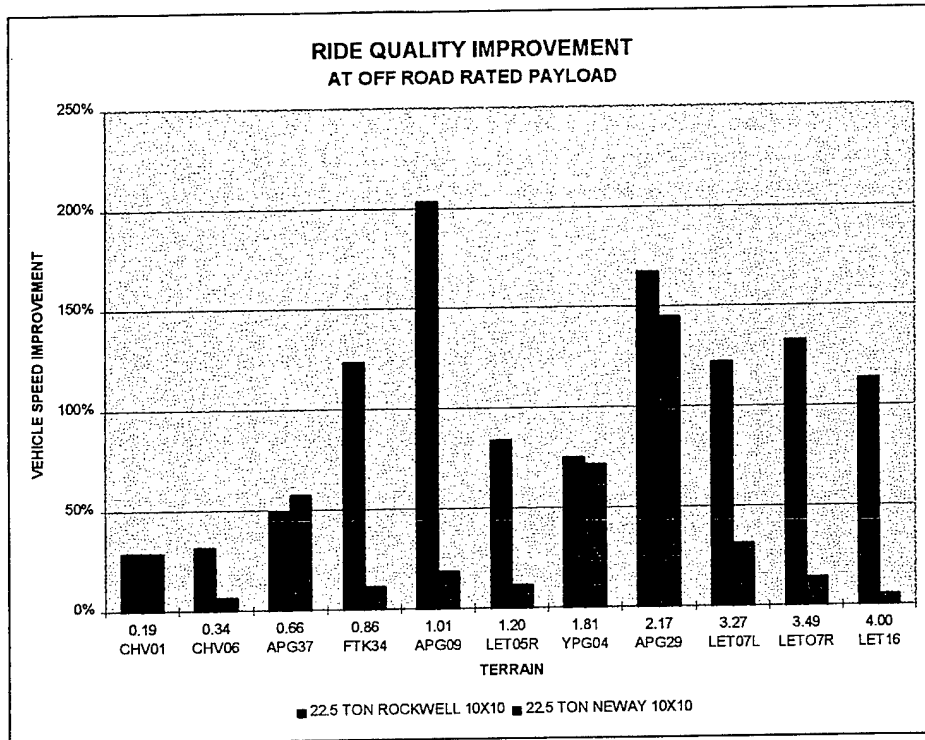

Figure 4.3.3-2a - Ride Quality Improvement (Rated Payload)

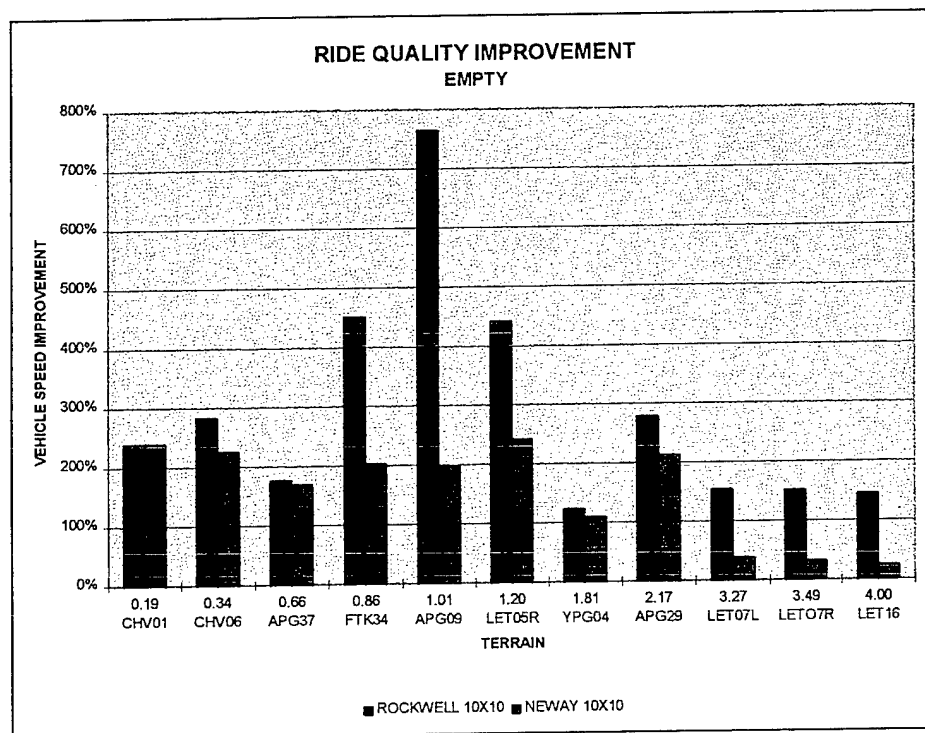

Figure 4.3.3-2b - Ride Quality Improvement (Empty)

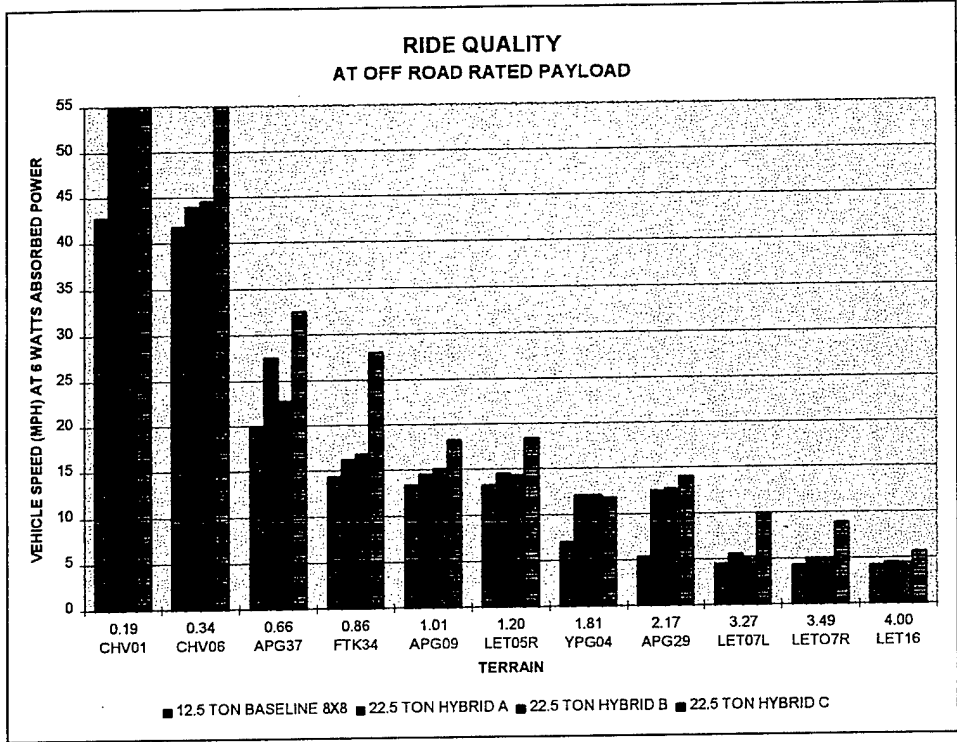

Figure 4.3.3-3a - Hybrid Vehicle Ride Quality Comparison (Rated Payload)

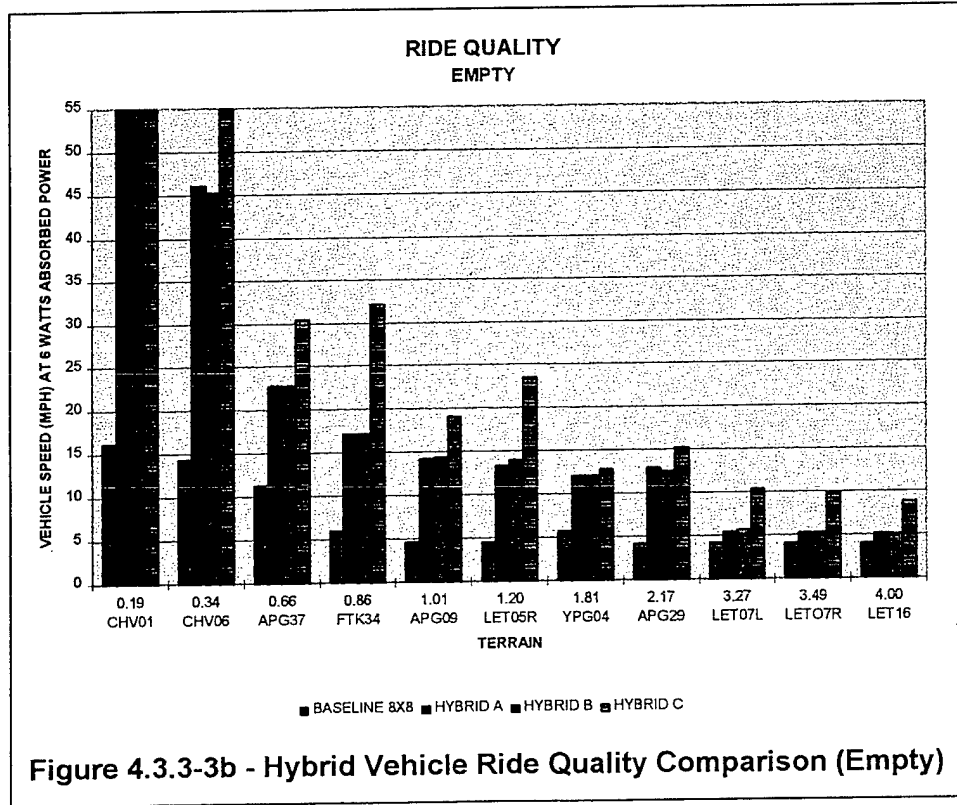

Figure 4.3.3-3b - Hybrid Vehicle Ride Quality Comparison (Empty)

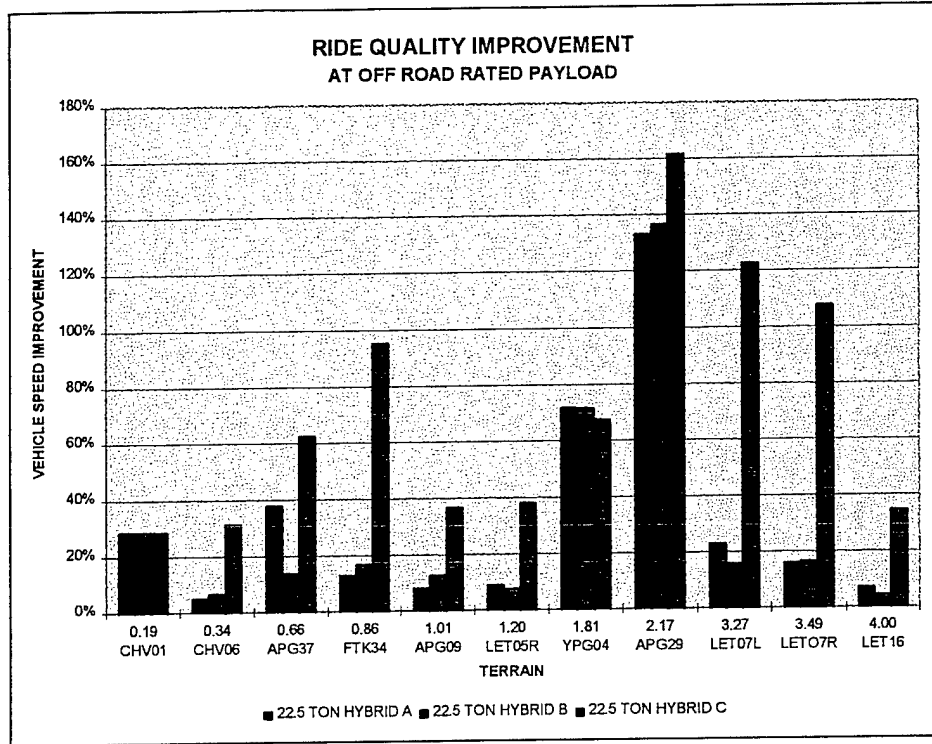

Figure 4.3.3-4a - Hybrid Vehicle Ride Quality Improvement (Rated Payload)

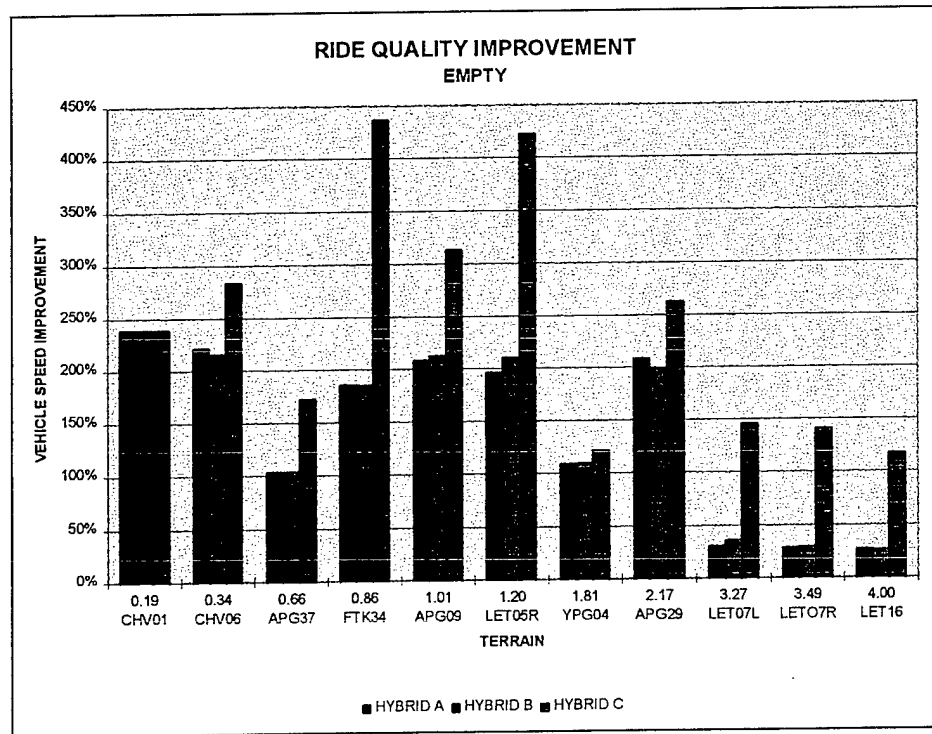

Figure 4.3.3-4b - Hybrid Vehicle Ride Quality Improvement (Empty)

All of these designs show performance improvements over the baseline LVS (Mk48/14). The Meritor independent suspension shows the greater promise for improvement in ride quality performance than the NEWAY suspension does, providing significantly better off-road ride quality over most terrain conditions, while providing an additional 10 tons of cargo capacity. With an empty vehicle the ride performance is equally impressive.

The VEHDYN2 analyses predict a minimum of 123% improvement in ride performance over terrain defined by terrain file YPG04 (1.81 in. RMS), and a maximum of 765% improvement over terrain defined by terrain file APG09 (1.01 in. RMS), for the empty vehicle. The analyses predict a minimum improvement of 29% over terrain defined by terrain file CHV06 (0.19 in. RMS), and a maximum of 203% improvement over terrain defined by terrain file APG09 (1.01 in. RMS) with the vehicle loaded with 22.5 tons payload.

This performance improvement prediction of 29% over CHV06 terrain does not reflect the true improvement provided by the suspension, in that this measure is truncated by the speed limit of the vehicle, not the ride quality. Vehicle limit velocities were not pursued past the 55 mph maximum speed of the vehicle.

The LVSR candidate concept vehicle, Hybrid C, which contains the Meritor independent suspension on the FPU and the NEWAY air bag suspension on the RBU performed almost as well as the "all Meritor" concept vehicle, except over terrain defined by terrain files FTK34 (0.86 in. RMS), APG09 (1.01 in. RMS), and LET05R (1.20 in. RMS).

4.3.4 Side Slope Performance

The Aberdeen Test Center performed static rollover tests on the Mk48/14 on their tilt table. The LVS was loaded with 12.5 and 22.5 Tons of payload, and with the tires inflated to various pressures. The results of these tests are given in **Tables 4.3.4-1 and 2**. The results indicate that the LVS exhibits very little margin for stability, over its 30% (16.7°) side slope requirement at 12.5 tons payload, and negative margin at GVW. Testing with various tire inflation pressures shows that off-road tire pressures have a significant effect on side slope stability.

Table 4.3.4-1 Static Rollover Results at 12.5 Ton Payload

STATIC ROLLOVER THRESHOLDS OF LVS W/25,000 LB PAYLOAD ^a		
Condition	degrees	Remarks
110 psi all around:		
Left side upslope	25.9	Wheel lift off; rollover all at once.
Right side upslope	25.7	Rollover; went all at once.
FPU 60 psi; RBU 55 psi:		
Left side upslope	24.6	Rollover; went all at once.
Right side upslope	24.6	Rollover; went all at once.
FPU 45 psi; RBU 35 psi:		
Left side upslope	-	Not attempted.
Right side upslope	21.6	Left rear tire rolled under severely; testing was stopped; no wheel lift off.

^aGross vehicle weight (66,500 lbs) minus curb weight (41,320 lb) equals 25,180 lb payload w/CG positioned 24 in. above deck.

Table 4.3.4-2 Static Rollover Results at 22.5 Ton Payload

STATIC ROLLOVER THRESHOLDS OF LVS W/45,000 LB PAYLOAD ^a		
Condition	degrees	Remarks
110 psi all around:		
Left side upslope	16.8	Rollover all at once.
Right side upslope	16.7	Rollover all at once.
FPU 60 psi; RBU 55 psi:		
Left side upslope	14.5	Close to rollover; testing halted due to need to realign tilt table cylinders.
Right side upslope	15.1	Rollover
FPU 45 psi; RBU 35 psi:		
Left side upslope	-	Not attempted
Right side upslope	-	Not attempted.

^aGross vehicle weight (85,960 lbs) minus curb weight (41,320 lb) equals 44,640 lb payload w/CG positioned 48 in. above deck.

If the off road payload is to be increased, side slope stability must be improved to provide comparable or better performance. A simple two dimensional kinematic model was made of the candidate LVSR concept vehicles, in order to predict side slope performance. A schematic of this model is shown in **Figure 4.3.4-1**.

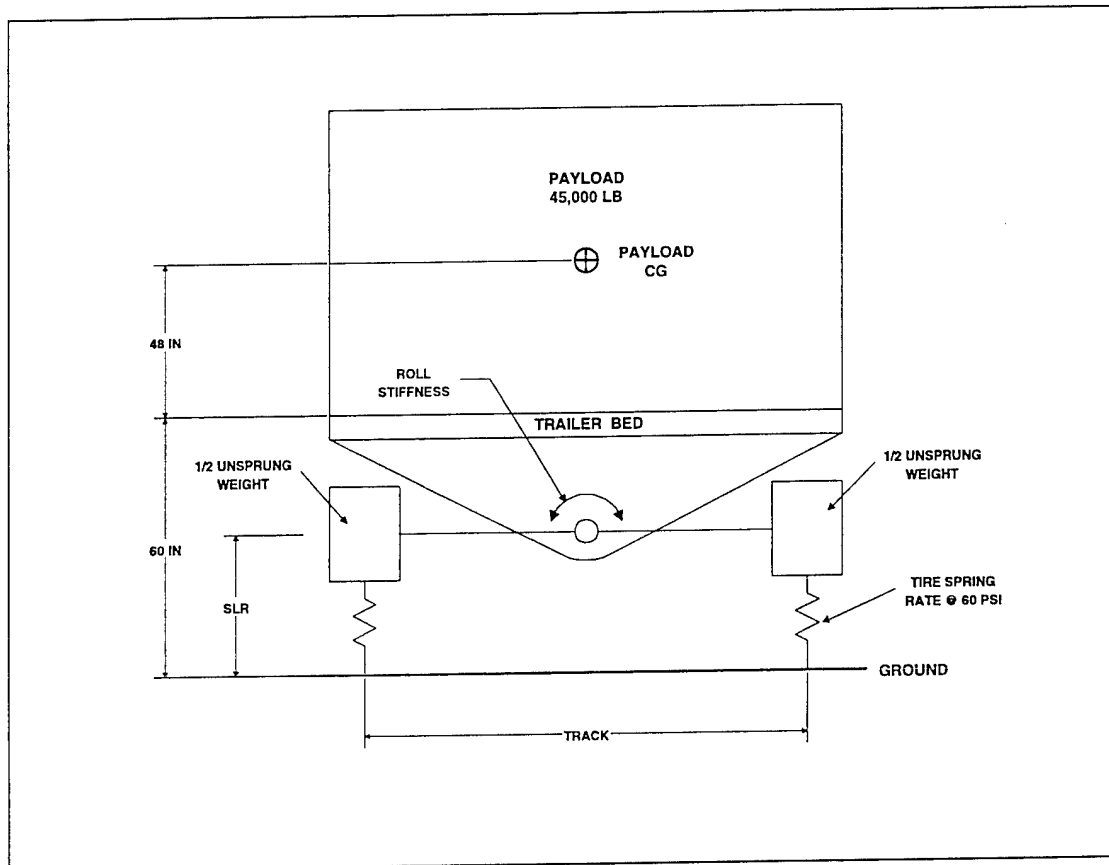

Figure 4.3.4-1 Rollover Model

The model was utilized to predict the wheel loading for the baseline LVS, in order to verify the model. The model was then modified to represent the LVSR concept vehicles with the Meritor and NEWAY suspension. Pertinent parameters of the various model configurations are given in **Table 4.3.4-3**.

The results of these analyses are given in **Table 4.3.4-4**. This table presents the results of the kinematic analyses of the RBU under the various side slope conditions.

Table 4.3.4-3 - RBU Roll Model Parameters

	LVS Baseline	Meritor	NEWAY
Sprung CG Height (in)	100	100	100
Sprung Weight (lb)	53,184	57,429	53,164
Unsprung Weight (lb)	7816	6219	10,124
Roll Center Height (in)	24	11.4	34
Track Width (in)	79	79.44	79
Roll Stiffness (ft-lb/deg)	24,975	21,912	13,125 (0-1.5°) 54,000 (>1.5°)
Tire Stiffness / Tire (lb/in)	3572	3572	3572
Tire Static Roll Radius (in)	24	24	24

Table 4.3.4-4 - RBU Suspension Roll Results

Suspension	Grade		Bed Tilt (deg)		Axle Tilt (deg)		Wheel Loads (% GVW)	
	%	DEG	ABS	WRTS	ABS	WRTS	Upslope	Downslope
LVS	30	16.70	26.07	9.37	20.17	3.47	11.6	88.4
LVS	35	19.29	30.08	10.79	23.32	4.03	5.5	94.5
LVS	37	20.30	31.63	11.33	24.58	4.28	3.0	97.0
Meritor	30	16.70	27.96	11.26	19.48	2.78	9.0	91.0
Meritor	33	18.26	30.48	12.22	21.26	3.00	5.3	94.7
Meritor	35	19.29	32.14	12.85	22.52	3.23	2.8	97.2
NEWAY	30	16.70	20.51	3.81	18.62	1.92	20.9	79.1
NEWAY	40	21.80	26.76	4.96	24.06	2.26	11.3	88.7
NEWAY	45	24.23	29.74	5.51	27.04	2.81	6.6	93.4

Bed tilt and axle tilt are presented, both in absolute coordinates and with respect to the side slope. The last two columns of this table present the upslope and downslope normal wheel loads as a percent of gross vehicle weight. As can be seen from these results the NEWAY suspension, with its higher roll stiffness, provides superior side slope performance. This NEWAY air ride suspension provides the lateral weight distribution of the baseline LVS 8X8 (at its 30% requirement) at up to 40% side slope. All analyses were performed with a 22.5 ton payload on the RBU.

4.4 Terrain Adaptive Technology

The modern generation of commercial and military wheeled vehicles are applying terrain adaptive automotive technologies. These systems include drivetrain management, central tire inflation systems and anti-lock braking

systems. Application of these technologies to the LVSR will enhance capabilities without adding a significant cost. Additionally, because these adaptive technologies can be made automatic, the training level of the operator will become much less of a mobility limitation.

4.4.1 Drivetrain

The current LVS drivetrain arrangement consists of an engine bolted directly to an automatic transmission which is connected, via a short drive shaft, to a two speed transfer case. The transfer case in addition to providing a high and low drive ratio has two power outputs. One transfer case output is toward the front axle assembly nose box, the other goes toward the rear axle assembly. Integral to the transfer case is a bevel gear differential assembly between the outputs which allows the front and rear output shaft speeds to change relative to each other. The front and rear axle bogies each have two axle assemblies with a drive shaft and inter-axle differential transferring power between them.

Power is split equally between each axle bogie and between each axle within each bogie on the LVS. The LVSR five axle arrangement requires the use of a biasing differential to direct more torque toward the rear three axles than the front two. A planetary differential in the transfer case will direct a larger portion to the torque toward the rear three axles to effectively balance the torque output with the cumulative axle loading. Within the rear three axles torque is again biased at the first axle with a planetary differential to direct two thirds of the torque to the rear two axles.

The LVS allows the drivetrain's interaction with the terrain to be modified as conditions change. On firm high coefficient of friction surfaces the vehicle drivetrain compensates for different wheel rolling diameters and different inside outside wheel speeds when the vehicle proceeds in other than a straight line. Differentials between the front and rear axle assemblies at the transfer case, between the axles within each bogie assembly, and between wheels on each axle permit different axle and wheel speeds. During marginal traction conditions differentials transmit torque to the least resistant bogie, axle, or wheel. This characteristic would limit the tractive effort of the LVS drivetrain to the bogie, axle, or wheel with the lowest tractive ability. To counteract the torque being limited to the least effective output, each differential assembly has a locks that eliminate the differential effect making the torque supplied to the differential the sum of each output, no longer limited to the lowest of the two outputs. Differential locks employed on the LVS are air operated jaw clutches controlled by the driver that cannot be engaged unless the vehicle is stopped. Differential locks should only be engaged during off road or marginal traction conditions. Forcing the respective wheel and axle assemblies to rotate at the same speed will cause excessive tire wear and induce high loads on the drive line if differential locks are engaged on paved or high coefficient of friction surfaces.

A two speed transfer case provides two different speed and torque ranges for high torque to negotiate steep grades with high rolling resistances in low range and high speeds for highway driving. The two speed case requires the driver to make decisions regarding the terrain encountered. Low range provides increased torque to the axles and increased tractive effort for off road and marginal terrain. The increased torque comes at the penalty of limiting the maximum speed that can be achieved. The operator must decide which range is appropriate for the terrain he will encounter and is forced to stop and change if he has chosen incorrectly or the terrain changes through the mission.

All decisions regarding vehicle configuration employed to adapt to the terrain are currently controlled by the vehicle operator. Good operators will make smart decisions and always employ the optimal vehicle configuration although even highly skilled drivers cannot adapt the vehicle on the move during a mission. Operators with less skill may not always be able to determine the optimal vehicle configuration for all terrains, which can result in increased mission times, or the vehicle being immobilized. Technologies exist that can assist the operator in making these decisions and make the implementation of terrain adaptation less difficult.

Implementing a system that can reduce the operators work load and automate some of the drivetrain configuration changes can, improve the LVSR's ability to adapt to marginal terrain, improve the mission effectiveness of the vehicle, and reduce operator training requirements. Automated drive line management is a system of sensors, electronic control modules and differential locks that adapt the vehicle drive line to marginal terrain. Sensors on each wheel monitor wheel spin and engage axle, inter-axle, and transfer case differential locks while the vehicle is in motion to limit wheel slip and maximize tractive effort. Engagement of the differential locks is accomplished while on the move under power completely transparent to the vehicle operator. The drive system control always selects the correct drive line configuration to optimize vehicle mobility.

Maximum tractive effort produced from drive wheels can be prevented from slipping during acceleration or towing. Wheel speed sensors can be used to sense slip and employ traction control to limit wheel slip. As wheel slip is sensed brakes are applied and engine power can be modulated to inhibit wheel slip, providing maximum tractive effort.

Presently major automotive suppliers offer proprietary approaches to applying these technologies to axles and transmissions. Meritor automotive employs clutches that are engaged while under power, Eaton employs an interrupt clutch at the transmission while clutches at the axles are engaged. Differences among the manufacturers will require that compatible components be supplied throughout the vehicle powertrain.

4.4.2 Central Tire Inflation

Another way to change the interaction of the vehicle with the terrain is to change the tire pressure. Tire pressure and tire side wall stiffness define the contact area and force per unit area the vehicle will use to support itself on the terrain. Decreasing tire pressure reduces the contact pressure by increasing tire contact area with the terrain, allowing a lower strength soil to support a given load. Lower tire pressures would always be used to increase mobility if it wasn't for the substantial negatives associated with the increased tire side wall flexing it produces. Increased tire side wall flex increases rolling resistance, increasing the power required to move a payload. This increased horsepower is dissipated in the form of increased tire temperature which eventually would destroy the tires by melting the rubber if excessive speed and load are used for an extended period of time. Tire temperature limits the load carrying capability of tires, and speed a given load can be transported.

Current LVS procedures require the operator to stop and exit the vehicle and manually change the pressure in each tire to adapt to terrain conditions. Deflating or inflating the tires can take up to an hour. This time penalty means the LVS tire pressure is not always optimized for its current terrain. This process can be simplified by adding Central Tire Inflation Systems (CTIS) which have become essentially standard equipment on the latest generation of wheeled military vehicles. Tire pressures can be adjusted from the vehicles operators cab as conditions change. Various control schemes can be implemented to adapt to different loads and terrains. Tire pressure can be varied from front to rear to compensate for loaded and unloaded conditions or side to side to increase roll stiffness. The system can also compensate for damaged tires that are leaking air by continuously supplying air to that tire and notifying the operator of the problem.

Commercially supplied axles and wheel hub have been modified to accept these systems. CTIS is a technology that originally was applied only to military vehicles that is now being marketed to commercial customers. This will reduce the cost of CTIS to the military user by increasing the production volume and reducing the unit cost. New axles incorporate the modifications required to supports CTIS and retrofit kits have been developed to apply the system to existing vehicles.

4.4.3 Anti-Lock Braking Systems (ABS)

ABS systems adapt the braking force at each individual wheel for its ability to slow the vehicle while maintaining rolling contact with the ground. Sensors at each wheel measure wheel speed and sense slipping conditions. This information is supplied to a controller that will modulate the braking force at each

wheel to prevent wheel slipping. Sensors used to measure wheel velocity would be the same sensors used in a terrain adaptive control system, providing a synergy which reduces the cost of each when both systems are applied to a vehicle.

Maintaining rolling contact between the wheels and the ground during braking with an ABS systems allows the operator to maintain control of the vehicle during stopping. Modulating braking force to limit braking force to the maximum achieved just prior to slipping produces the maximum braking force available for that wheel. Maintaining control allows the vehicle to obtain good deceleration on marginal traction surfaces like ice or loose gravel, on straight roads or while negotiating curves.

5. Recommended Concept Definition

5.1 System Description

Based on the Concept Exploration findings the Recommended LVSR configuration was defined as:

- 1) 10X10 suspension configuration
- 2) A diesel engine with similar size and performance characteristics to the Perkins CV6 diesel engine rated at 600 hp
- 3) A transmission with similar size and performance characteristics to the Allison HD 4070 transmission
- 4) A suspension system with similar size and performance characteristics to the Meritor (Rockwell) independent suspension for the front power unit
- 5) A suspension system with similar size and performance characteristics to the NEWAY air suspension for rear power unit
- 6) Central tire inflation
- 7) Anti-lock brakes
- 8) Traction control

The functional block diagram shown in **Figure 5.1-1** shows the relationship of the major elements of the power plant, drive-train, suspension and traction systems. As can be seen the operation of each of these systems is dependent on adjoining systems as well as operator inputs.

Operator Interface

The LVSR driver station will be very similar to the predecessor system (LVS). The same cab structure, seat and many of the controls will be re-used. Additional controls will be added for the selection of operating mode and central tire inflation. The operating mode selection will be used to tailor the vehicle mobility systems for the desired mode of operation. Three operating mode options will be made available; 1) primary road, 2) secondary road, and 3) cross country. Based on the mode setting the suspension, drive-train and anti-lock braking system will be adjusted to optimize performance. Four central tire pressure settings will be made available; 1) highway (110 psi), 2) cross country (60 psi), 3) mud/snow/ice (35 psi) and 4) emergency (15 psi). These pressure settings will be selected by the driver based on terrain type. To reduce driver training requirements a system for automatic operation of the mode and central tire inflation system will be considered. Therefore, during the development of the Advanced Technology Demonstrator, systems for automatically sensing the correct mode and terrain type will be evaluated.

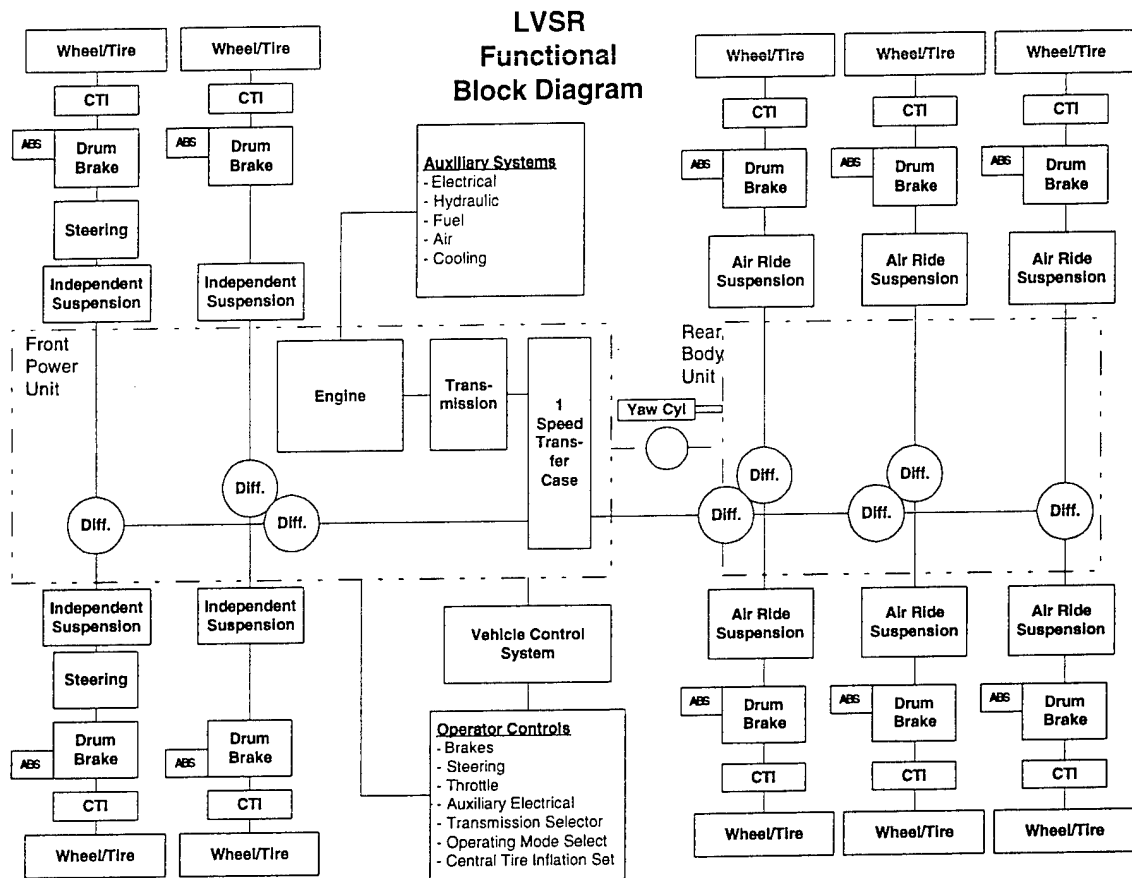

Figure 5.1-1 LVSR Functional Block Diagram

One major operational difference between the LVS and the LVSR will be the interface between the operator's controls and the vehicle systems. In the LVSR this interface will be electrical via the use of a central vehicle control system and an SAE J1939 data bus. This approach is necessary to increase automated control options and to take advantage of on board diagnostics.

In addition to the trafficability and ride performance predictions generated during the Concept Exploration a detailed 3-D Dynamic analysis of the Existing LVS and Recommended LVSR Concept was conducted using ADAMS software. Virtual dynamic testing results that are presented in **Section 5.2** includes:

- 1) Turning circle (Shortest turning diameter)
- 2) 30% side slope operation
- 3) Tilt table testing
- 4) Lateral acceleration
- 5) Lane change maneuver

In all tests, the Recommended LVSR with a 17.5 ton payload meet or exceeded the performance of the Baseline LVS with a 12.5 ton payload.

The following sections provide a brief description of each of the major systems selected for the Recommended LVSR.

5.1.1 Power Plant

The combined goal of increasing the horsepower installed in the LVSR while minimizing the physical changes required to implement that change, result in an engine selection that supplies high horsepower densities and a V configuration that is similar to the 8V-92T that is currently installed. Reviewing the engines considered as part of this study show the Perkins CV6 provides the highest installed horsepower per pound and an engine length that is similar to the existing engine. An engine that provides improved power density and meets EPA requirements should be an excellent candidate for a LVSR program. Although this engine is based on existing engine designs its configuration is developmental. The progress of the design, development and production should be continuously monitored to compare the engine development schedule with the LVSR development.

To supply uninterrupted power to the drive line and enough gear ratio range to eliminate the need for a two speed transfer case in a weight efficient package the Allison HD 4070 transmission best meet the needs of the LVSR. This transmission incorporates electronic control that can be integrated into a vehicle electronic control system. The HD 4070 transmission model is a higher mechanical ratio coverage version of the Allison "World Transmission". The 4070 adds a seventh range clutch pack low ratio package to the rear of the standard transmission. The HD 4070 has been designed and produced for commercial applications requiring 500 horsepower. This transmission will benefit from the logistics base obtained from the broad base of commercially installed systems. Laboratory testing has been successfully completed at 800 gross horsepower in anticipation of specialty vehicle ratings for off highway and military applications.

5.1.2 Suspension

The suspension recommended for the LVSR employs Meritor Independent Suspension Axle System (ISAS) on the Front Power Unit (FPU) and NEWAY AD-Series Air-Ride suspensions on the Rear Body Unit (RBU). This approach was selected because it improved both the ride and side slope performance capability. The 8 inch jounce travel of the ISAS provides the vehicle crew with a much more compliant suspension than the existing LVS resulting in smoother rides and fewer suspension bottomings. The NEWAY Air Ride suspension provides an improved ride in all but the most sever terrain conditions. The ride height control valve that regulates the airbag pressure adjusts the suspension

spring rate according to the load. Unlike the fixed spring used in the existing RBU suspension, the load compensating feature of the NEWAY Air-Ride allows the spring to be tailored for both the loaded and unloaded configurations. This results in an improved ride at a controlled height regardless of payload condition. The torque tube feature of the AD Series provides the added advantage of increased roll stiffness that results in much improved side slope stability.

5.1.3 Terrain Adaptive Systems

Terrain adaptive systems including traction control, Central Tire Inflation Systems (CTIS) and Anti-Lock Braking Systems (ABS) can provide substantial performance improvements with minimal cost impact on LVSR. Although developing terrain adaptive systems requires a large development effort the installed cost on a vehicle is quite moderate if it is designed in to new axle assemblies when compared to the other major vehicle components. Except for CTIS the system cost would be prohibitive if it were retrofitted to the existing vehicle components. Sensors and clutches mated to an electronic controller will evenly split power to each wheel to limit wheel slip on marginal surfaces. On LVSR implementing a terrain adaptive system can provide improvements in vehicle performance and reductions in operator training requirements. The particular system applied will be dependent on the transmission and axles used on the production vehicle. By selecting an Allison transmission The Meritor Terrain adaptive system would be used because it has the capability to engage and disengage clutches while being powered. This system would only be compatible with their axles. These captive designs limit component selection and force the vehicle designer to specify the entire drive train as a system employing a particular manufactures components. This may change if terrain adaptive systems increase in popularity and the number of commercial installations increase.

5.1.4 Steering System

It is recommended that an improved steering system be investigated for the LVSR. The results of the User Survey indicate that the current system is difficult to trouble shoot and maintain. Other undesirable features of the steering system that have been reported to AAI during this study include:

- 1) Excessive free play in front suspension
- 2) Time delay between driver input and yaw steering
- 3) Difficult to control at high speed
- 4) Excessive tire wear due to improper front axle to yaw steering ratio

5.2 Dynamic Analysis

Dynamic analysis of the LVSR was conducted via the ADAMS (Automatic Dynamic Analysis of Mechanical Systems) software. Two major models were constructed for this analysis:

- A baseline model which represents the existing LVS (Mk48/Mk14)
- A revised model incorporating the Recommended LVSR suspension

In both models the mass, center of gravity and moment of inertia characteristics of the major vehicle components are accurately represented to effect realistic overall vehicle dynamic behavior. Suspension system models are high fidelity representations including gaps (e.g. between LVS leaf spring ends and axle housing brackets), travel-limit chains, bumper stops and damping. Non-linear spring/damping rates are used where data were available.

The objective of the dynamic analysis was to first establish baseline performance by exercising the baseline LVS model over a battery of virtual proving ground tests for a variety of payloads, tire pressures and velocities; subsequently the Recommended model was exercised over the same courses in order to compare the dynamic response characteristics of the two vehicles. Test courses considered in the analysis include turning circle, 30% side slope, tilt table, lateral acceleration and lane change maneuvers. Payloads include 25, 35 and 45 kips (2, 3 and 4 feet tall respectively), and tire pressures include 40, 60 and 102 psi.

Modeling

The basic ADAMS model is shown in **Figure 5.2-1**, illustrating the major structural features. Frame members are interconnected using compliant bushings in the locations shown to allow flexing of the frames. The engine/transmission, transfer case and cab structure are modeled as lumped masses connected via bushings to the Mk48 frame, as is the cargo deck with respect to the Mk14 frame. Leaf spring models pivot on the trunnions and are connected to the axle housings through spring forcing functions which incorporate logic for lateral and vertical free play. Drive torque is applied separately to each wheel as described below in the discussion of the propulsion system; desired speed is achieved/maintained via cruise control logic. Front wheel steering is accomplished by establishing a path curve which describes the course of interest, and dynamically applying to the left front wheel knuckle a steering torque proportional to the deviation of the vehicle heading from the curve; the right wheel is steered by the tie rod part connecting the knuckles. Yaw steer torque is applied at the yaw joint according to the logic discussed below.

The "Fiala" tire model was used for the analyses. ADAMS tires are theoretical entities which define force interactions with a road surface. The road is described by three dimensionally located nodes connected by triangular elements. ADAMS uses tire input parameters to determine what reaction forces should be applied to the vehicle wheel hubs based on their position, attitude, and velocity with respect to the road surface. Input parameters for the tires include radial stiffness, the first partial derivative of the friction coefficient versus longitudinal slip ratio function, lateral force per radian of slip angle, lateral force per radian of camber angle, rolling resistance coefficient (defined as a fraction of the instantaneous vertical load), tire damping ratio, and the tire/road friction coefficients at zero slip and at complete sliding. The values used for the dynamic models were obtained from test data furnished to AAI by Michelin for their 16.00 R 20 tires. Tire reactions to dynamic conditions are composed of four separate load vectors. The vertical forces are due to radial spring rate and damping. The longitudinal forces are due to slip ratio, rolling resistance, and slip angle. Lateral forces and aligning moments are due to slip angle only.

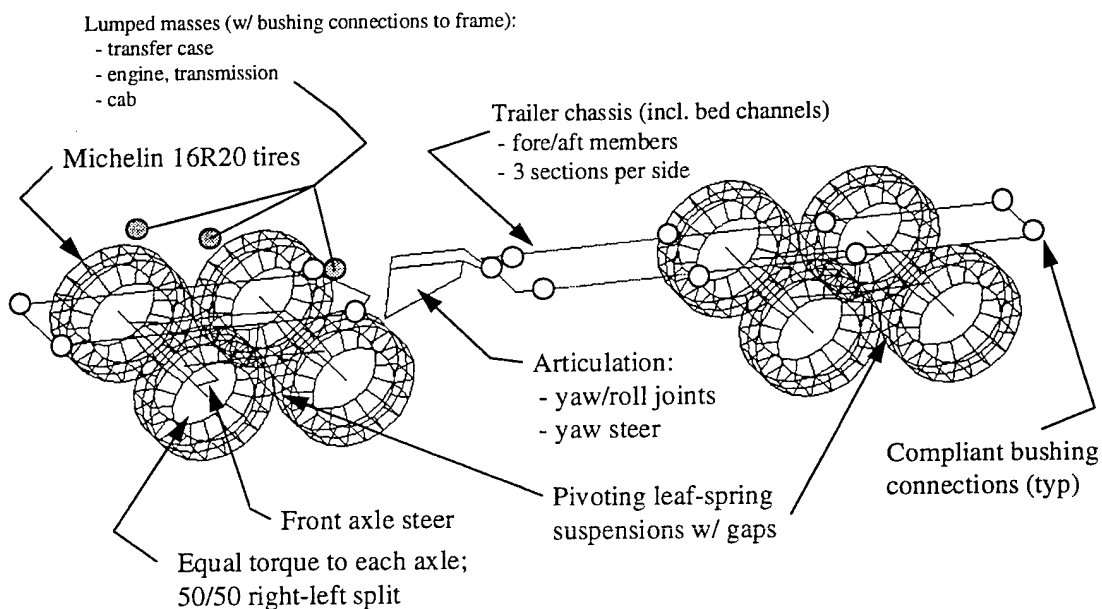

Figure 5.2-1 Basic ADAMS Model Structure

Special control algorithms were developed for propulsion and yaw steer. The propulsion system performance characteristics of the model were based on the SCAAN data file "538129.txt" which was sent to AAI Corporation from Allison Transmission "David_J._Sagers@notes.atd.gmeds.com". Tractive effort, transmission status, engine RPM, and engine torque data for an auxiliary drop-box ratio of 2.120 was used to construct an analytical algorithm. The objective was to use the SCAAN data to construct an analytical propulsion system that

would accept a throttle position as input and give a total wheel output torque in return. ADAMS would use this algorithm in conjunction with analytical cruise control logic to "drive" the model at the requested speeds.

Draw bar pull forces were used to back calculate wheel output torque based on loaded tire radii. The combination of engine RPM, back calculated wheel torque, and transmission gear ratio were then combined to create data points for the total drive-train torque versus engine RPM, and gear ratio at full throttle. This data was then curve fitted. Throttle dependence was introduced by employing a periodic sine function as a multiplying factor. During ADAMS simulations, engine RPM was continuously updated based on instantaneous wheel RPM and loaded tire radius. The engine idle speed was assumed to be 500 RPM. This is the data point at which the torque versus RPM curves for all throttle positions intersect. The drive-train differential torque splits were represented by applying the appropriate fraction of total wheel output torque to the appropriate wheels. The equations used to calculate the instantaneous total wheel output torque are shown below. Appropriate logic was added to prevent the application of negative torque (i.e. the engine torque approaches zero when $S < 500$).

$$T_w = (A_i S^2 + B_i S + C_i) / N$$

Where: T_w = Total wheel output torque
 S = Instantaneous engine speed in RPM
 N = Overall gear ratio between engine flywheel and tires
 $A_i = \{S_o^2 A_{ft}^2 + S_o A_{ft} B_{ft} + B_{ft}^2 / 4\} / \{T_o - T_{max\ i}\}$
 $B_i = 2S_o \{A_{ft} - A_i\} + B_{ft}$
 $C_i = T_o - A_i S_o^2 - B_i S_o$

and

S_o = Engine idle speed (RPM) = 500
 T_o = Engine only output torque at idle = 5624.5 inch pounds
 $T_{max\ i}$ = Max engine only output torque at given throttle position
 $T_{max\ i} = (15150 \text{ in}\cdot\text{lb}) \sin\{(.06f_t + 0.4)\pi/2\}$
 f_t = Throttle factor $[0 \leq f_t \leq 10]$
 0 = idle
 10 = full throttle
 A_{ft} = Full throttle quadratic coefficient = -.01
 B_{ft} = Full throttle linear coefficient = 29.525

The above relations yield Total output wheel torque as a function of throttle position (f_t), overall gear ratio (N), and engine speed (S). Instantaneous engine speed (S) is determined iteratively within ADAMS by multiplying tire rotational speeds by the overall gear ratio. Five overall gear ratios were used. Four of them correspond to the lockup ratios and one represents the drive train characteristics during converter operation prior to first gear lockup. The

algorithm causes the transmission to shift gears at predetermined vehicle speeds. Simple logic was employed to define "N" as a function of vehicle speed. A cruise control algorithm adjusted the throttle position to achieve the desired vehicle speed during each simulation run. The ADAMS model contains a physical throttle pedal and return spring. The cruise control algorithm applies the appropriate force to the pedal based on an exponential function with dependence on the current vehicle simulation speed, and the desired vehicle simulation speed. The throttle position range is from zero to ten and is used as f_t in the equation for total wheel output torque above.

Torque is applied to the yaw joint based on the difference between the desired yaw angle and the actual yaw angle (yaw error). In an ideal orientation (no error), the yaw angle would be 2.08 times the steer angle. This value was determined from the geometry of the yaw steer linkage system with rigid links. The actual LVS applied torque is governed by a Vickers model SV20 Hydraulic Steering Valve which has some finite linear travel (non-rigid link). Based on geometry, peak hydraulic pressures, and cylinder size, the maximum applied yaw torque for the LVS is approximately 600,000 inch pounds. A rigid yaw steer control linkage has been analyzed, and found to exhibit a linear translation of .082 inches at the control valve location for each degree of angular rotation at the yaw joint. Therefore, if the fusible link length changes by .082 inches, the yaw joint error will be one degree. When the ADAMS analyses were conducted, the precise details of the Vickers valve characteristics were not available. The following assumptions were therefore used for the analyses. This valve is closed (applies no yaw torque) when the linear error is 0.00 inches (yaw angle error is zero degrees). The valve is fully open (applies maximum yaw torque) when the linear travel at the valve control ball stud attachment is 0.25 inches (yaw angle error is three degrees). A cubic spline equation was used for the applied yaw torque versus yaw error for values between zero and three degrees.

Recommended LVSR 10x10 Vehicle Modeling

Modeling of the Recommended LVSR 10x10 configuration differs from the baseline 8x8 in suspension characteristics and drive-train torque distribution. Whereas for the 8x8 configuration the drive gearing is such that equal torque is applied to each of the eight wheels, the torque distribution for the 10x10 drive-train provides 30% of the total available torque to the FPU (15% to each axle with 50/50 split left to right) and 70% to the RBU. 30% of the RBU's total torque goes to axle 3, with the remainder equally split between axles 4 and 5, again with 50/50 split left to right for each RBU axle. The ADAMS model featuring the Meritor (Rockwell) and NEWAY suspensions is illustrated in **Figure 5.2-2**. Details of the suspensions, showing the major structural components, are shown in **Figures 5.2-3 and 5.2-4**. Spring load versus deflection and shock load versus velocity functions are based on curve fits of data supplied by the

manufacturers, e.g. **Figure 5.2-3**. Vertical travel at each wheel is limited in both up and down directions via appropriate force function logic.

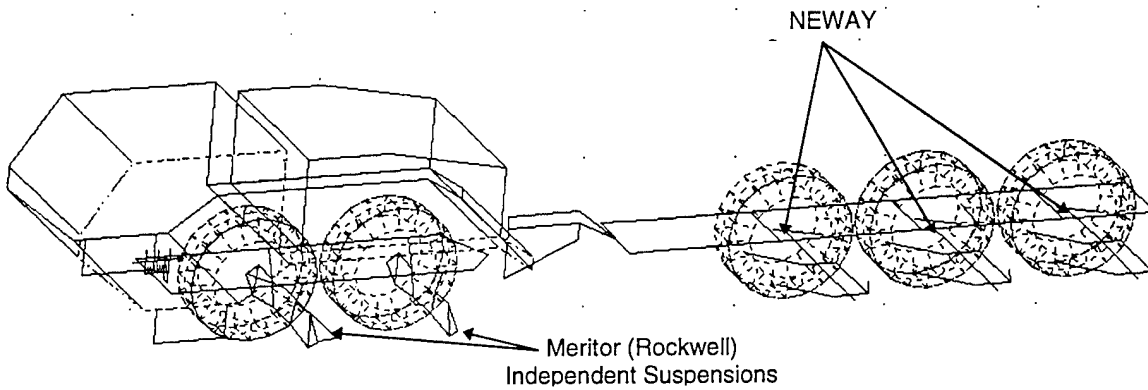

Figure 5.2-2 Model with Recommended LVSR Suspension (deck and left side wheels omitted for clarity)

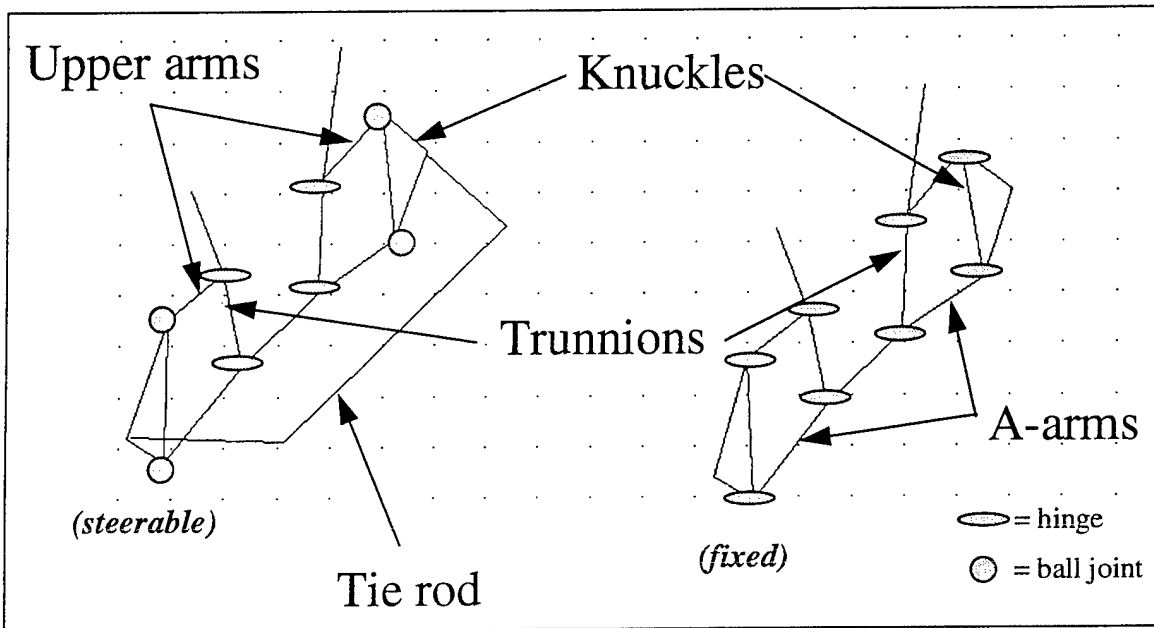

Figure 5.2-3 Meritor (Rockwell) Suspension Components

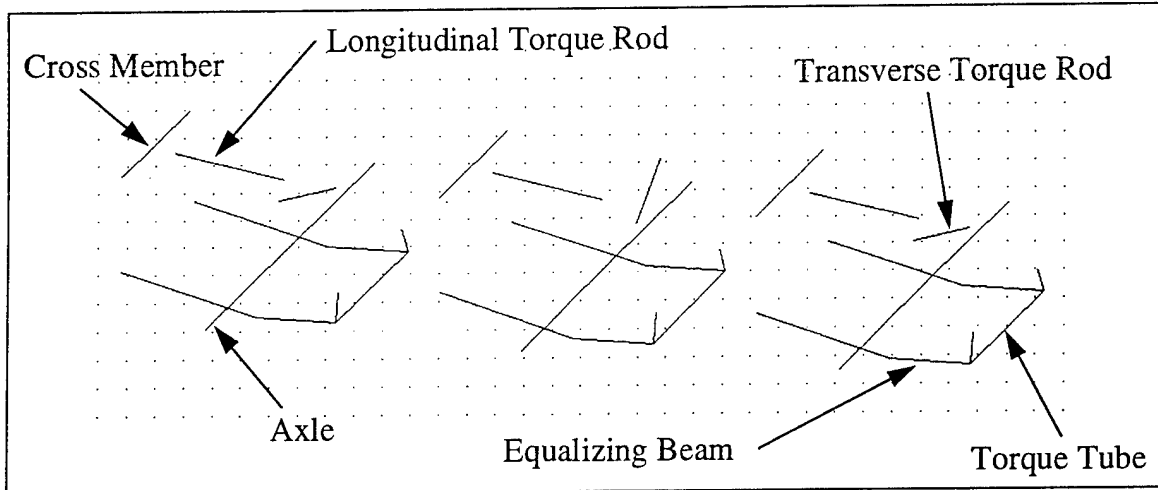

Figure 5.2-4 NEWAY Typical Suspension Components, Showing Staggered Transverse Torque Rod Arrangement

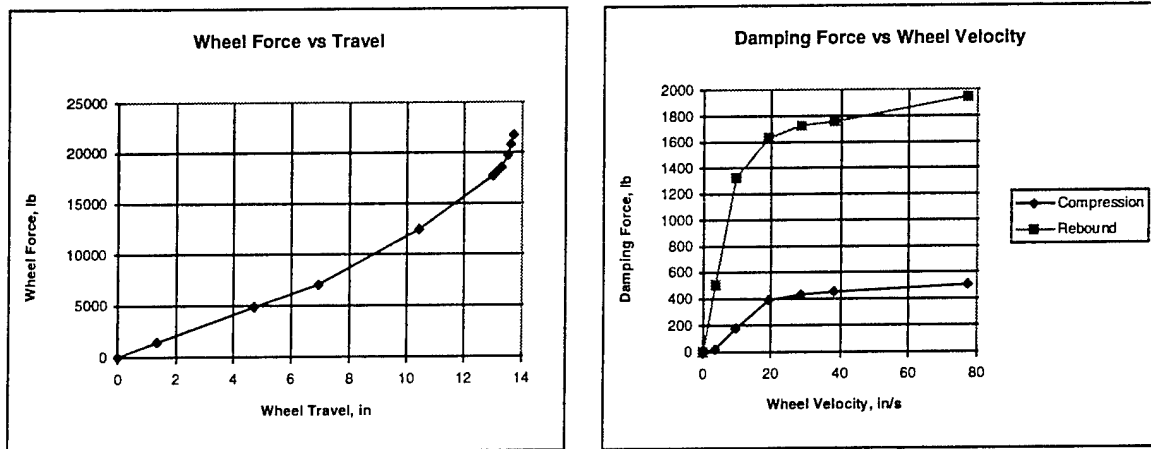

Figure 5.2-5 Fitted Meritor (Rockwell) Suspension Data

5.2.1 Turning Circle

Turning circles were evaluated at 5 mph at full steering lock (15 degrees front wheel steer) to measure minimum curb-to-curb and wall-to-wall turning diameters. Results for the LVS model and the Recommended LVSR vehicle model are shown below, including curb-to-curb and wall-wall turning circles, yaw steer torque and engine power required to negotiate the circle.

(LVS)

Payload (x 1000 lb)	Tire Pressure (psi)	Vehicle Speed (mph)	Turning Circle Diameter (ft)		Yaw Steer Torque (ft-kip)	Engine Power (hp)
			Curb-curb	Wall-wall		
25	40	5.3	74.4	78.0	26.4	26.4
25	60	5.5	73.8	77.5	29.0	27.7
45	40	5.1	74.1	77.8	30.8	28.6
45	102	5.5	73.0	77.6	38.8	33.4

(Recommended LVSR)

Payload (x 1000 lb)	Tire Pressure (psi)	Vehicle Speed (mph)	Turning Circle Diameter (ft)		Yaw Steer Torque (ft-kip)	Engine Power (hp)
			Curb-curb	Wall-wall		
35	40	5.3	74.8	78.4	16.6	57.5
35	102	5.6	74.1	77.7	17.7	61.0
45	40	5.2	74.8	78.4	16.8	61.8
45	102	5.5	74.0	77.5	18.0	68.4

These results indicate little difference in the turning circle diameters. The Recommended LVSR vehicle requires less yaw steer torque, but consumes more engine power to negotiate the circle.

An attempt was made to decrease the minimum turning radius by applying a "skid steer" technique. A control function was developed to calculate the instantaneous slip ratio of each tire, and apply braking torque of the appropriate magnitudes to maintain maximum stopping traction. The maximum stopping traction occurs at a slip ratio of approximately 20% on smooth dry road surfaces. The braking action was applied to several different combinations of tires during simulated turning maneuvers. The most successful combination was both MK48 left tires at maximum anti-lock braking during a full-lock left turn. As the vehicle slowed below the desired speed of five miles per hour, the cruise control gradually applied full throttle. The turning radius decreased by approximately two feet relative to the same model without "skid steering". When 20% slip braking was applied to more than two wheels simultaneously, the vehicle was brought to rest by the braking action even under full throttle. Other combinations involving four tires were tried using 15%, and 10% slip ratios, but none showed a significant increase in performance.

5.2.2 Side Slope Operation

Side slope stability was evaluated at 10 mph on a 30% slope. Both straight line and sinusoidal paths were evaluated, as shown in **Figure 5.2.2-1**. The sinusoid evaluated has a 4-foot lateral amplitude and a 76-foot period.

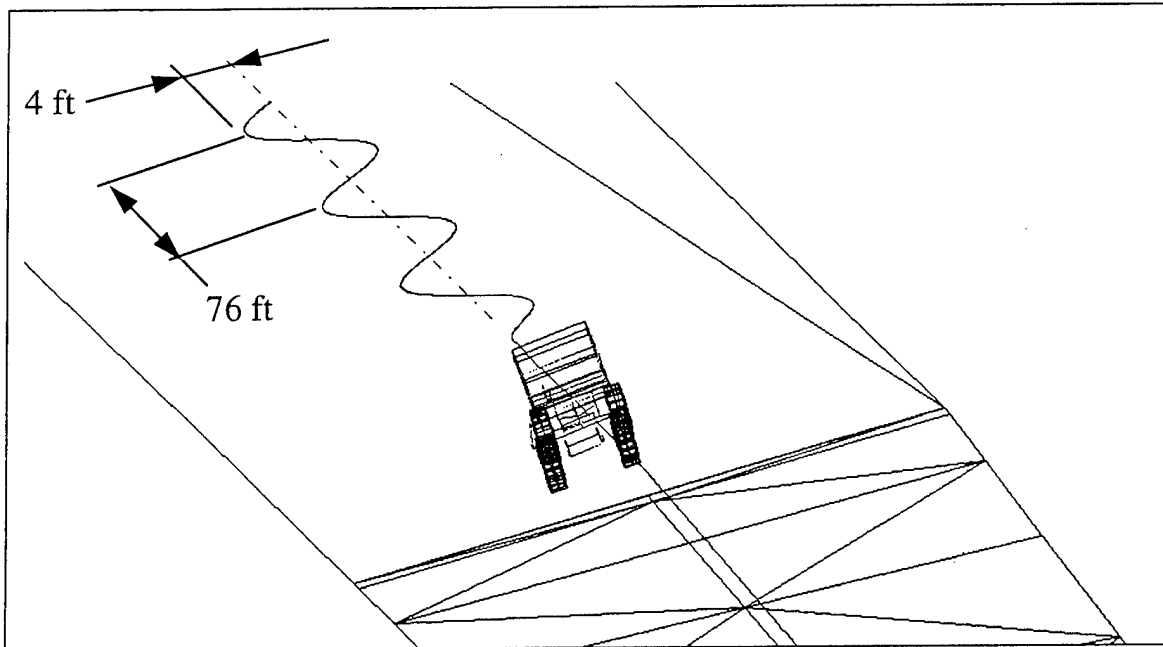

Figure 5.2.2-1 Side Slope with Obstacle Avoidance

In ADAMS, the approach to the slope is modeled as a series of gradual, progressive increases in grade. Once at full grade, the vehicle travels in a straight line along the slope for 50 feet before commencing the sinusoidal obstacle-avoidance maneuver. Results for the LVS are shown below, including off-track (measured uphill parallel to the slope over the vehicle wheel base), tilt of the FPU and RBU, and minimum tire loads for the straight-line and sine sweep portions of the tests.

(LVS)

Payload (x 1000 lb)	Tire Press (psi)	Off- Track (in)	FPU Tilt (deg)		RBU Tilt (deg)		Min. Tire Load (lb)	
			straight	sweep	straight	sweep	straight	sweep
25	40	21.5	22.0	23.8	23.7	24.7	3443	1941
25	60	18.3	21.4	23.1	22.8	23.8	3540	1870
45	102	-	-	-	-	-	-	-

With the 45,000-lb payload, the LVS model became unstable, tipping over before reaching full-grade slope, as shown in **Figure 5.2.2-2**. (Note that the

discrete grade increments in the model induce additional dynamic roll effects on the approach, which are partially responsible for the onset of this behavior.) Results of similar measurements for the Recommended suspension are shown below.

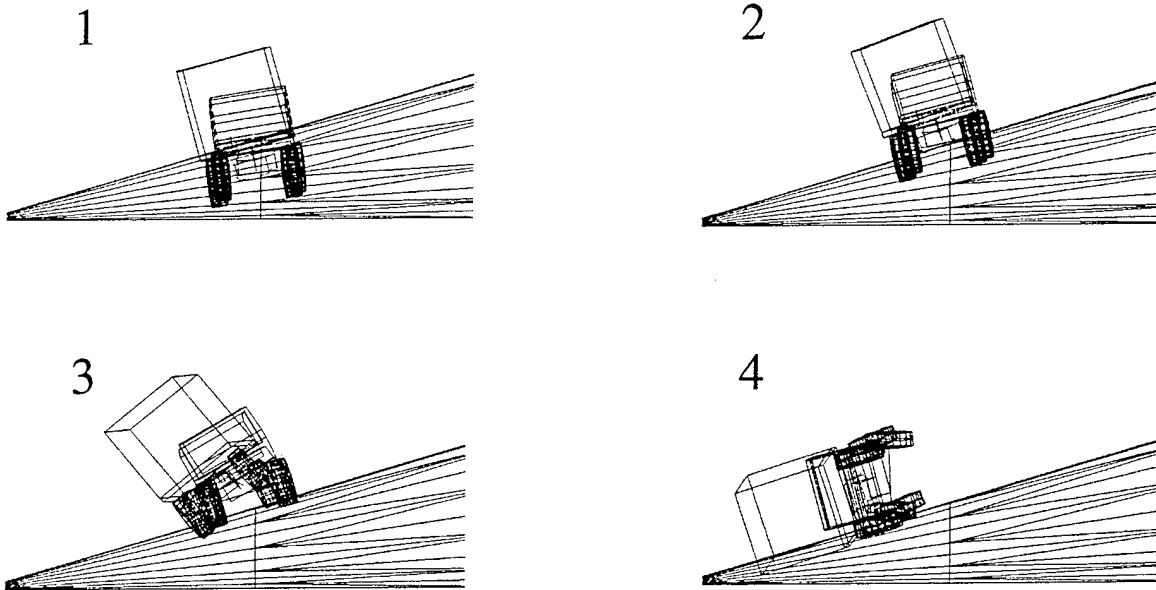

Figure 5.2.2-2 LVS with 45k Payload on 30% Side Slope

(Recommended)

Payload (x 1000 lb)	Tire Press (psi)	Off- Track (in)	FPU Tilt (deg)		RBU Tilt (deg)		Min. Tire Load (lb)	
			straight	sweep	straight	sweep	straight	sweep
35	40	21.0	23.0	25.9	22.0	23.6	1810	0
35	102	14.6	21.9	24.8	20.4	21.7	2001	0
45	40	29.3	23.5	-	24.3	-	330	-
45	102	19.4	22.2	-	21.8	-	1030	-

These results indicate greatly improved side slope stability with the Recommended suspension. With the 35k payload, the aft upslope tire lifted at both tire pressures during the sine sweep maneuver, but the vehicle did not tip. With the 45k payload, the vehicle tipped during the sine sweep; however, with the on-road tire pressures, tip over occurred only during the second upslope portion of the maneuver. **Figure 5.2.2-3** shows the Recommended LVSR vehicle negotiating the slope with the 45k payload. Compare with **Figure 5.2.2-2**.

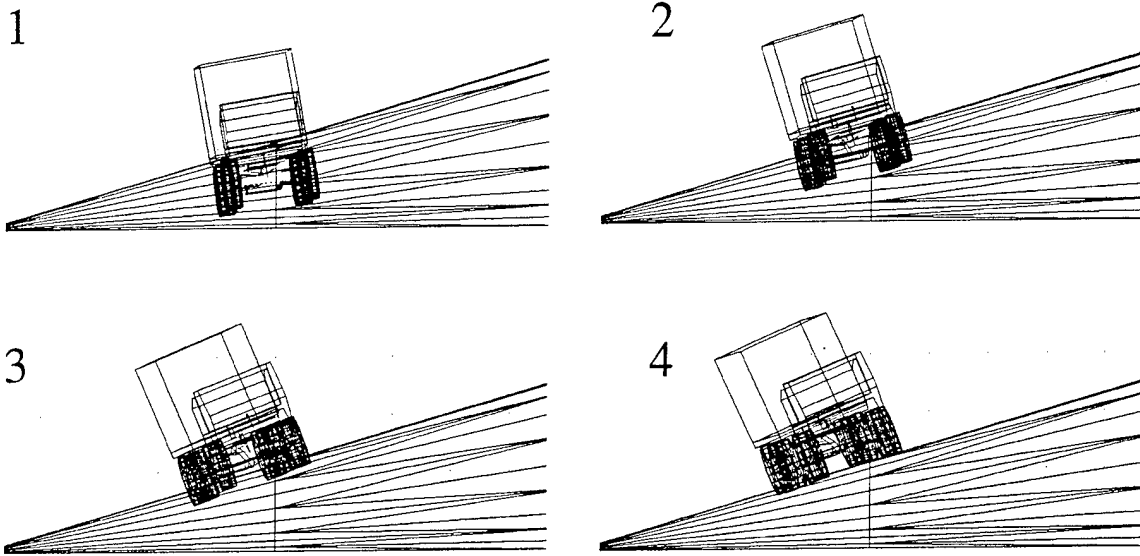

Figure 5.2.2-3 Recommended Vehicle with 45k Payload on 30% slope

5.2.3 Tilt Table Test

Tilt table tests were conducted at 30% grade (16.7 deg). Due to limitations of the tire model under lateral static loads, for this test the tire models were replaced with forcing functions based on curve fits to tire radial and lateral loading data supplied by Michelin. **Figure 5.2.3-1** shows such a curve fit for the tire at 102 psi.

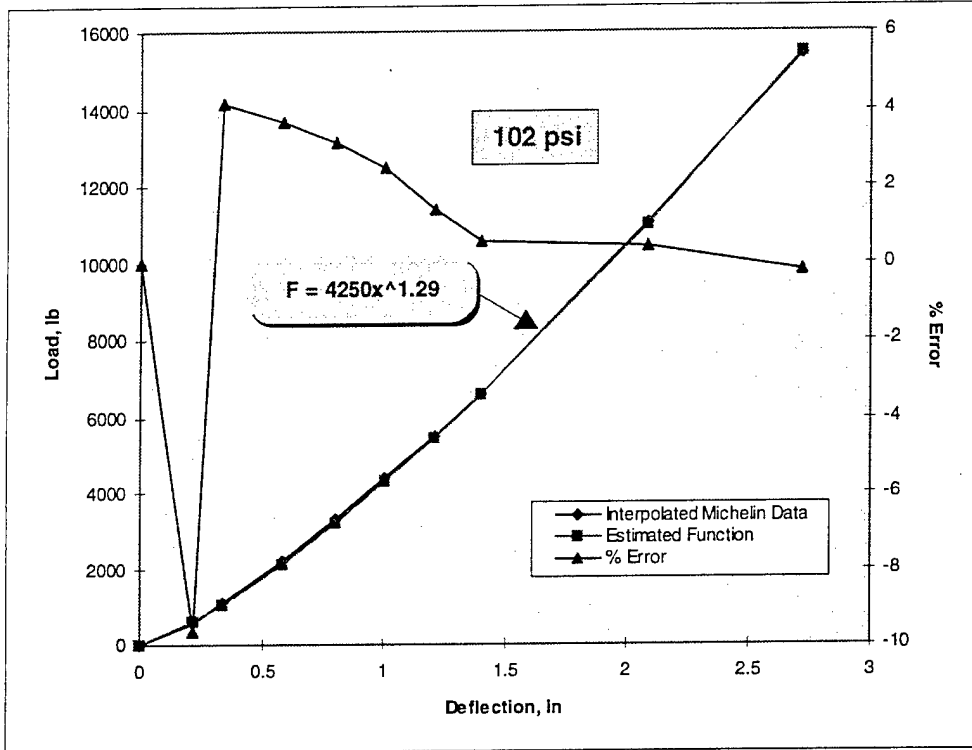

Figure 5.2.3-1 Curve Fit of Michelin Data for Tilt Table Tire Spring

Results for the LVS and the Recommended vehicle, including tilt of the FPU and RBU and minimum wheel load perpendicular to the slope are shown below.

(LVS)

Payload (x 1000 lb)	Tire Press (psi)	FPU Tilt (deg)	RBU Tilt (deg)	Min. Tire Load (lb)
25	40	21.1	22.6	4286
25	60	20.9	22.2	4345
45	40	25.3	31.6	578
45	102	22.3	28.3	1537

LVSR(Recommended)

Payload (x 1000 lb)	Tire Press (psi)	FPU Tilt (deg)	RBU Tilt (deg)	Min. Tire Load (lb)
35	40	20.3	21.3	2283
35	102	19.8	20.2	2255
45	40	20.6	23.2	1875
45	102	20.0	21.5	2180

The results indicate a significant improvement in stability with the Recommended suspension. Direct comparison of the 45k results show significantly less lean and greater upslope wheel loads with the Recommended. **Figure 5.2.3-1** gives a visual comparison of the two vehicles with a 45k payload.

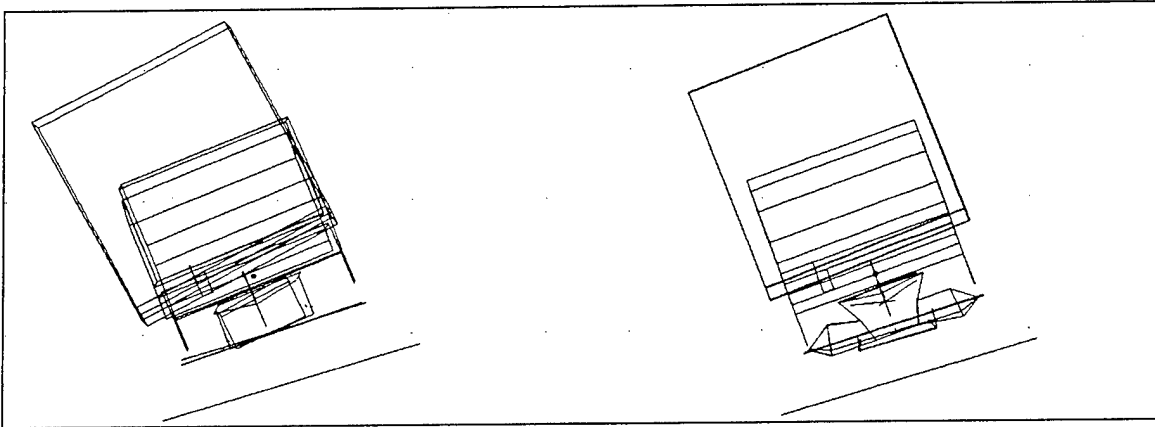

Figure 5.2.3-1 30% Tilt Table Comparison: 45k Payload for LVS (left) and Recommended Vehicle (right)

Tilt Table Threshold Analysis

Tilt table analysis was conducted over a range of tilt angles for each configuration to determine its analytical tip-over threshold angle. The tabulations below give the results for the LVS and recommended LVSR configurations. In each case the last two tilt angles run are listed: the last stable configuration run, and an unstable one.

LVS

Payload (lb)	Tire Pressure (psi)	Unstable at: (angle, deg)	Table Angle (deg)	Last Stable Analysis		Min Tire Load (lb)
				FBU Angle (deg)	RBU Angle (deg)	
25k	60	31.0	29.0	38.5	37.5	572
45k	102	19.0	18.5	25.2	31.3	136

LVSR

Payload (lb)	Tire Pressure (psi)	Unstable at: (angle, deg)	Table Angle (deg)	Last Stable Analysis		Min Tire Load (lb)
				FBU Angle (deg)	RBU Angle (deg)	
35k	102	31.0	29.0	34.3	35.0	75
45k	102	25.0	23.0	27.5	29.8	86

5.2.4 Lateral Acceleration

Lateral accelerations were evaluated on a 75-foot radius circle to determine the maximum attainable speed before the vehicle becomes unstable. For each configuration, speed multiples of 5 mph were programmed into the model cruise control (i.e. 10, 15, 20, etc). Results were examined to determine if liftoff of any wheel occurred. The tabulations below reflect results of the last successful tests before liftoff occurred (e.g. if liftoff occurred at 20 mph, then results for 15 mph are listed). Note that, due to tolerance in the cruise control algorithm, the speeds are typically not exact multiples of 5 mph. **Figure 5.2.4-1** illustrates the instability of the LVS with 25k payload at 25 mph on this course.

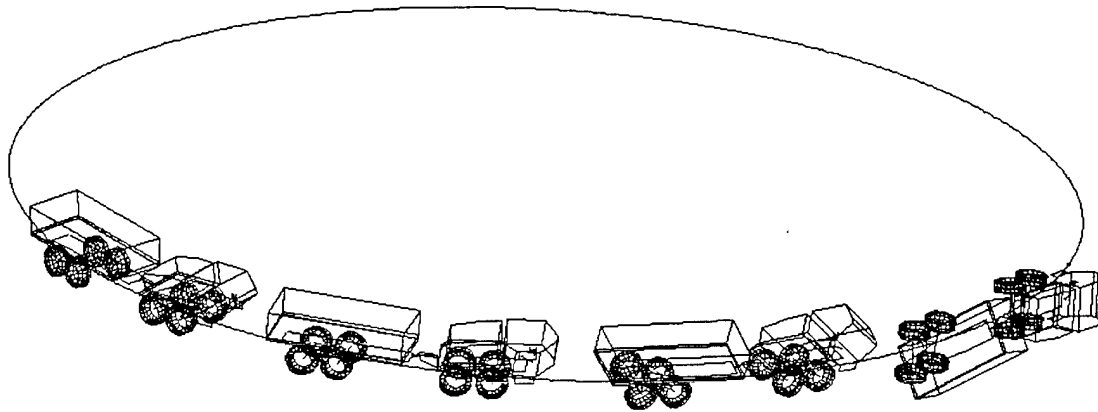

Figure 5.2.4-1 LVS with 25k Payload at 25 mph on 75-foot Circle

Results of the dynamic analysis for the LVS and Recommended LVSR suspensions are shown below, including lateral acceleration measured at the payload center of gravity and minimum wheel load.

(LVS)

Payload (x 1000 lb)	Tire Press (psi)	Speed (mph)	Lat'l. Accel (g's)	Min. Tire Load (lb)
25	40	19.0	0.33	1960
25	60	19.7	0.35	1660
45	40	14.0	0.18	1640
45	102	16.0	0.23	1040

(Recommended LVSR)

Payload (x 1000 lb)	Tire Press (psi)	Speed (mph)	Lat'l. Accel (g's)	Min. Tire Load (lb)
35	40	18.9	0.33	870
35	102	19.7	0.35	470
45	40	15.4	0.16	2253
45	102	16.5	0.19	1478

Note that the results for the Recommended LVSR suspension with a 35k load are very similar to those of the LVS with 25k. Also the 45k results show lower payload accelerations and higher wheel loads at slightly higher speeds for the Recommended suspension relative to the LVS.

5.2.5 Lane Change Maneuver

A lane change maneuver was performed to determine the maximum speed at which the vehicle could safely negotiate the evasive maneuver course specified by SAE J2014. The course used in the ADAMS model is shown in **Figure 5.2.5-1**. The 81.2-foot dimension is based on the SAE specification of $[(2 \times \text{WB}) + L]$, where WB is the vehicle wheelbase and L is the vehicle overall length.

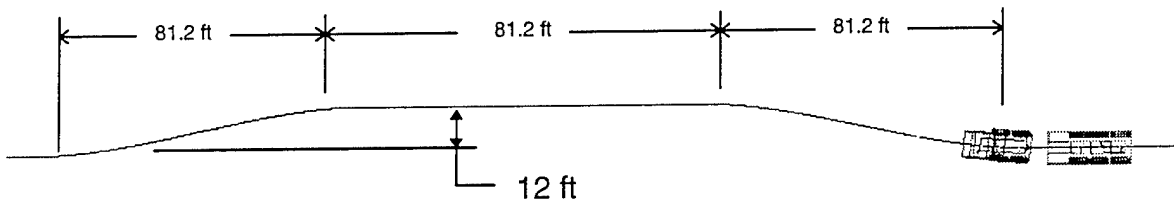

Figure 5.2.5-1 Lane Change Course

Results for the LVS and Recommended LVSR vehicle are shown below, including speed, lateral acceleration measured at the payload cg and minimum tire load. As with the lateral acceleration tests above, the speeds tested were multiples of 5 mph.

(LVS)

Payload (x 1000 lb)	Tire Press (psi)	Speed (mph)	Lat'l. Accel (g's)	Min. Tire Load (lb)
25	40	25.0	0.31	1315
25	60	26.0	0.29	1860
45	40	15.3	0.10	5075
45	102	17.3	0.12	6050

(Recommended) LVSR

Payload (x 1000 lb)	Tire Press (psi)	Speed (mph)	Lat'l. Accel (g's)	Min. Tire Load (lb)
35	40	25.2	0.34	413
35	102	20.8	0.21	2638
45	40	19.4	0.16	2680
45	102	20.7	0.17	2364

The Recommended LVSR vehicle results for a 35k payload are similar to those for the LVS with 25k load, and those for the 45k payload show the Recommended LVSR vehicle demonstrating stability in the next higher test bracket than for the LVS. Typical lateral acceleration and tire load time histories for the lane-change course are shown in **Figure 5.2.5-2**.

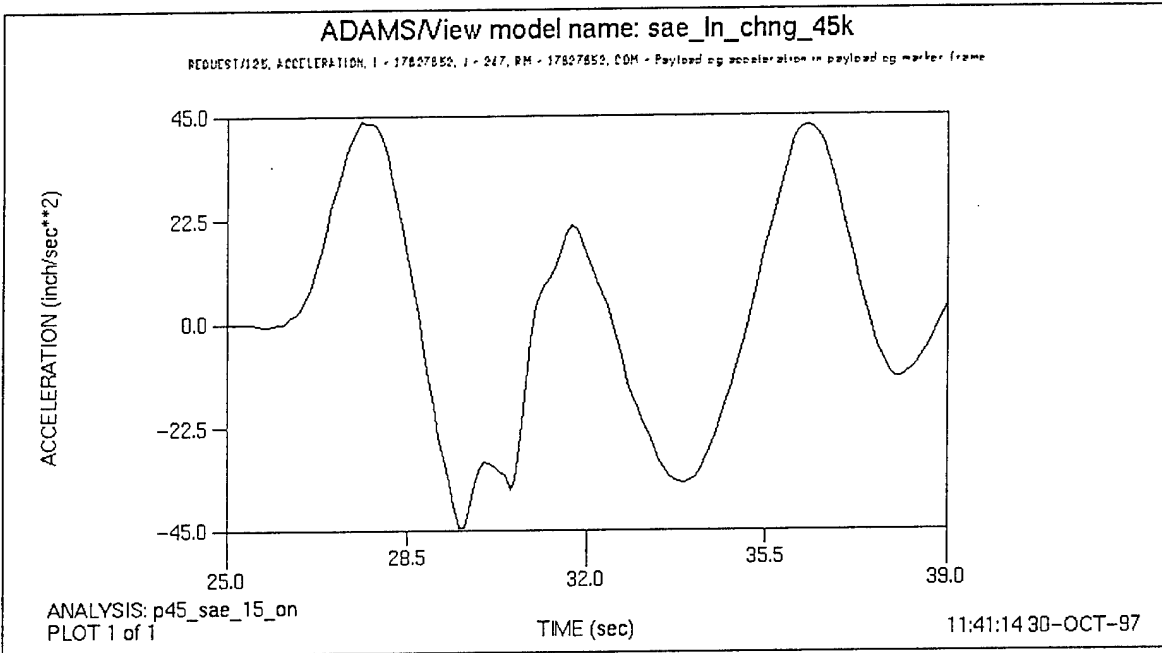

Figure 5.2.5-2 Lateral Acceleration vs Time for LVS, 25k Payload at 15 mph, 102 psi tires

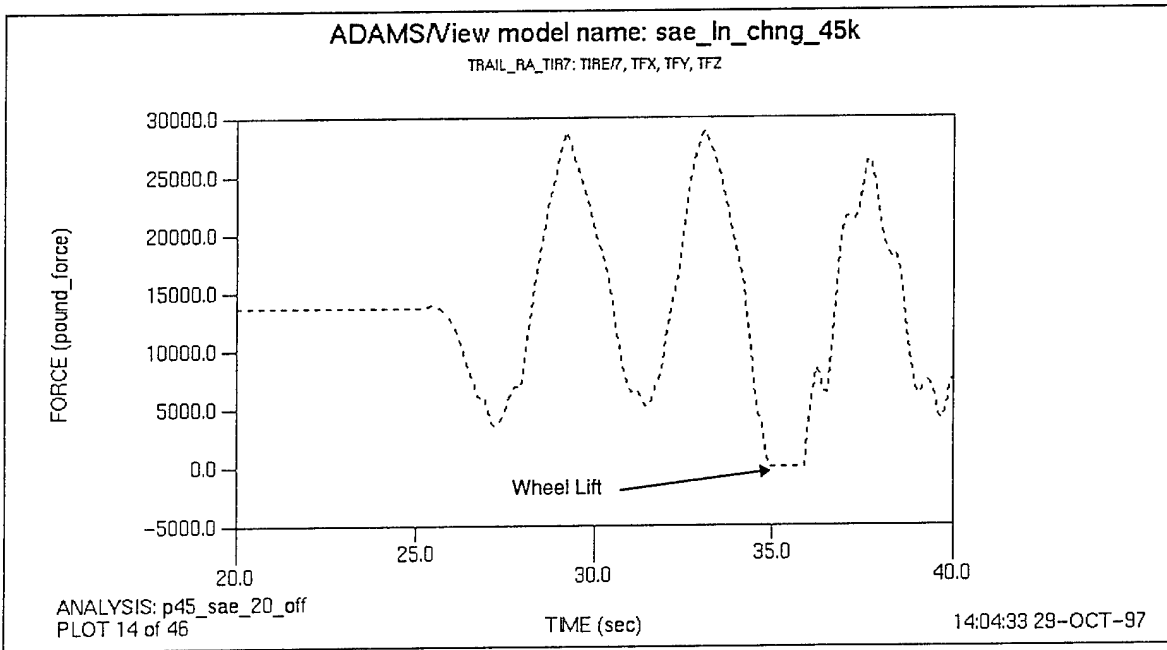

Figure 5.2.5-3 Tire Vertical Load vs Time for LVS, 25k Payload at 20 mph, 40 psi Tires

5.3 Mobility

5.3.1 Trafficability

The trafficability predictions for the recommended LVSR concept vehicle design provide a significant improvement over the baseline LVS (Mk48/14) vehicle performance. The results of the trafficability analyses for this concept vehicle are given in **Table 5.3.1-1**, and are shown graphically in **Figures 5.3.1-1 and 2**.

This concept vehicle is capable of providing the user with a single cargo capacity of 22.5 tons on and off road, while maintaining trafficability performance at comparable levels with the baseline vehicle which is only loaded to 12.5 tons payload capacity.

HYBRID C				
AXLE	EMPTY	12.5 T	17.5 T	22.5 T
1	13,405	14,396	14,936	15,477
2	13,405	14,396	14,936	15,477
3	5805	13,237	16,210	19,183
4	5738	13,170	16,143	19,116
5	5562	12,994	15,967	18,940
VCI ₁ *	16.27	17.77	20.28	25.71
% Improvement	2.28	26.23	40.55	38.51

Table 5.3.1-1 - Recommended LVSR Concept Vehicle Trafficability Performance

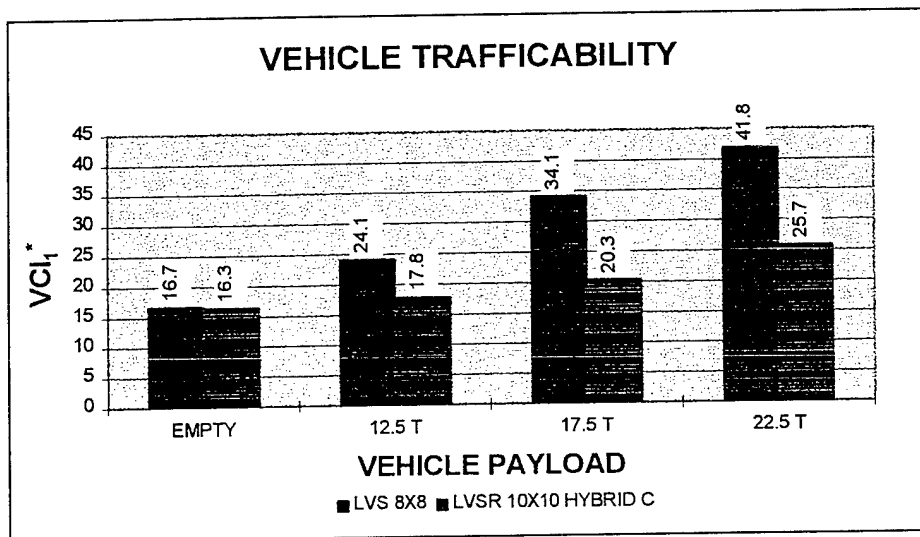

Figure 5.3.1-1 - Trafficability Performance

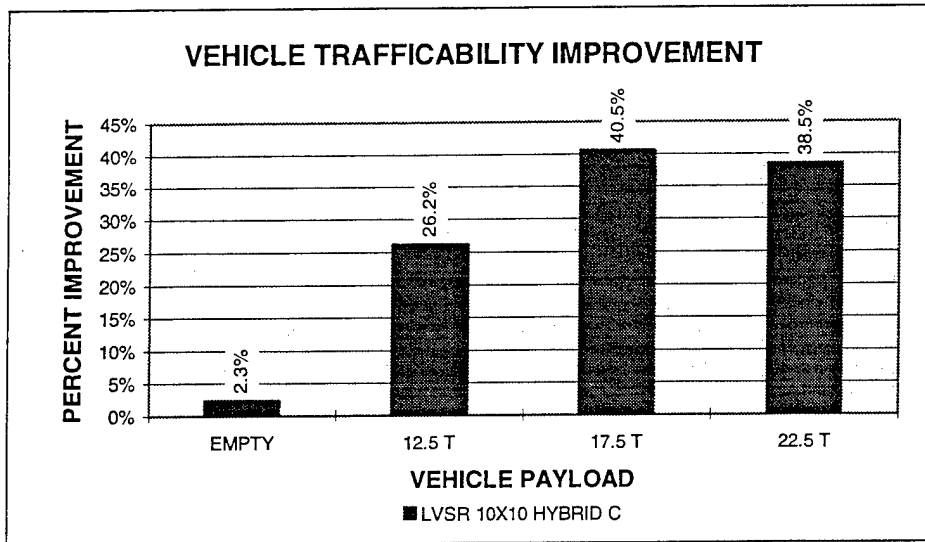

Figure 5.3.1-2 - Predicted Trafficability Improvement

5.3.2 Ride Quality

The VEHDYN2 input data file was modified to reflect the recommended LVSR concept vehicle definition. Ride quality predictions were obtained from VEHDYN2 analyses of this data file. Details of pertinent suspension characteristics are shown in the following illustrations.

Figure 5.3.2-1 shows the force / deflection characteristics of the Meritor (Rockwell) springs used for the two axles in the FPU. **Figure 5.3.2-2** shows the force / deflection characteristics of the NEWAY air bag spring used on axle 3,4 and 5 in the RBU, scaled for the static load pertinent to the LVSR at 22.5 ton payload. **Figure 5.3.2-3** shows the force / velocity characteristics of the shock absorber used in the Meritor suspension. **Figure 5.3.2-4** shows the force / velocity characteristics of the shock absorber used in the NEWAY suspension, scaled for axle motion.

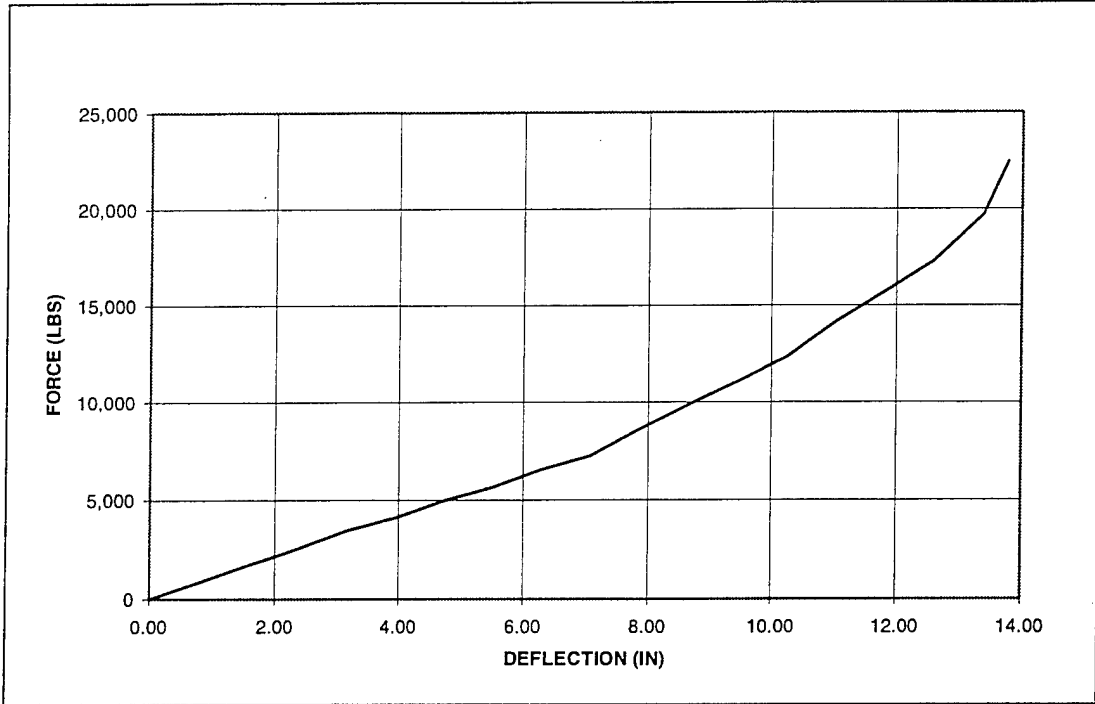

Figure 5.3.2-1- Meritor (Rockwell) Suspension Spring Characteristics

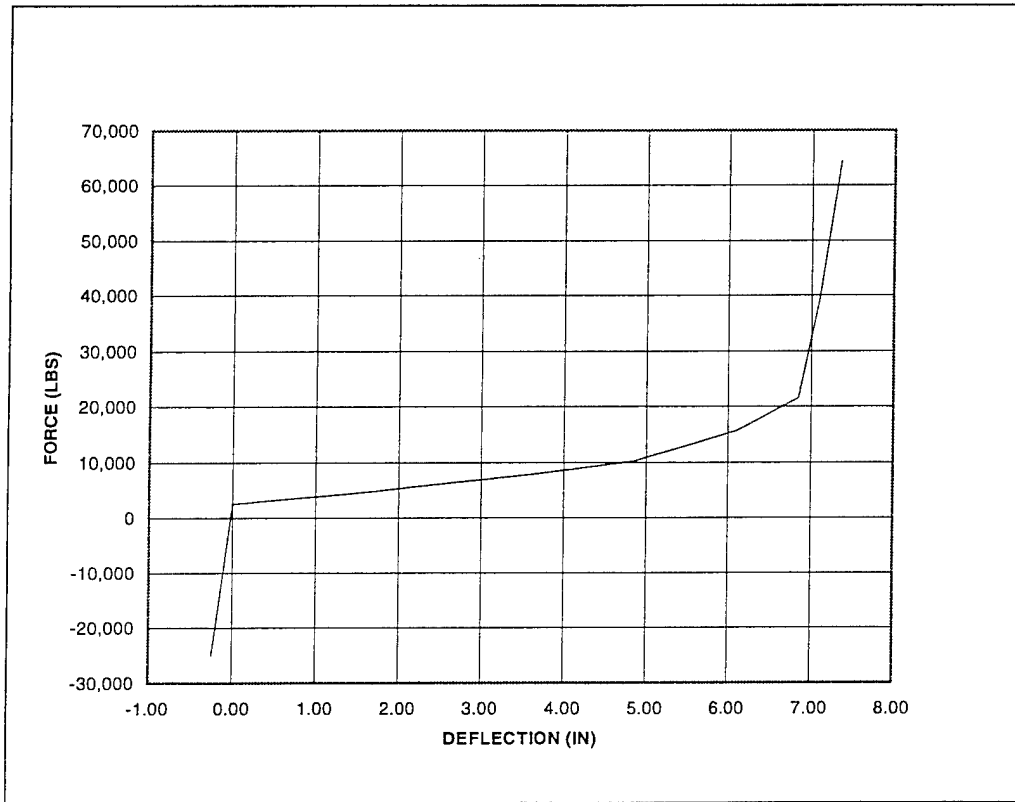

Figure 5.3.2-2 - NEWAY Suspension Spring Characteristics

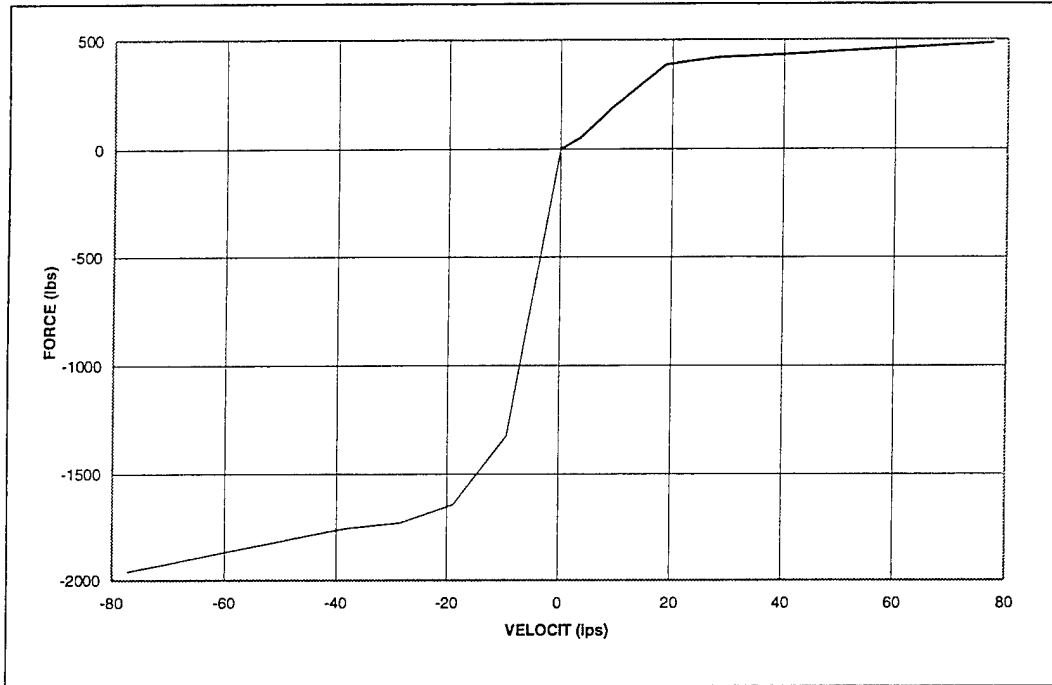

Figure 5.3.2-3 - Meritor (Rockwell) Suspension Damper Characteristics

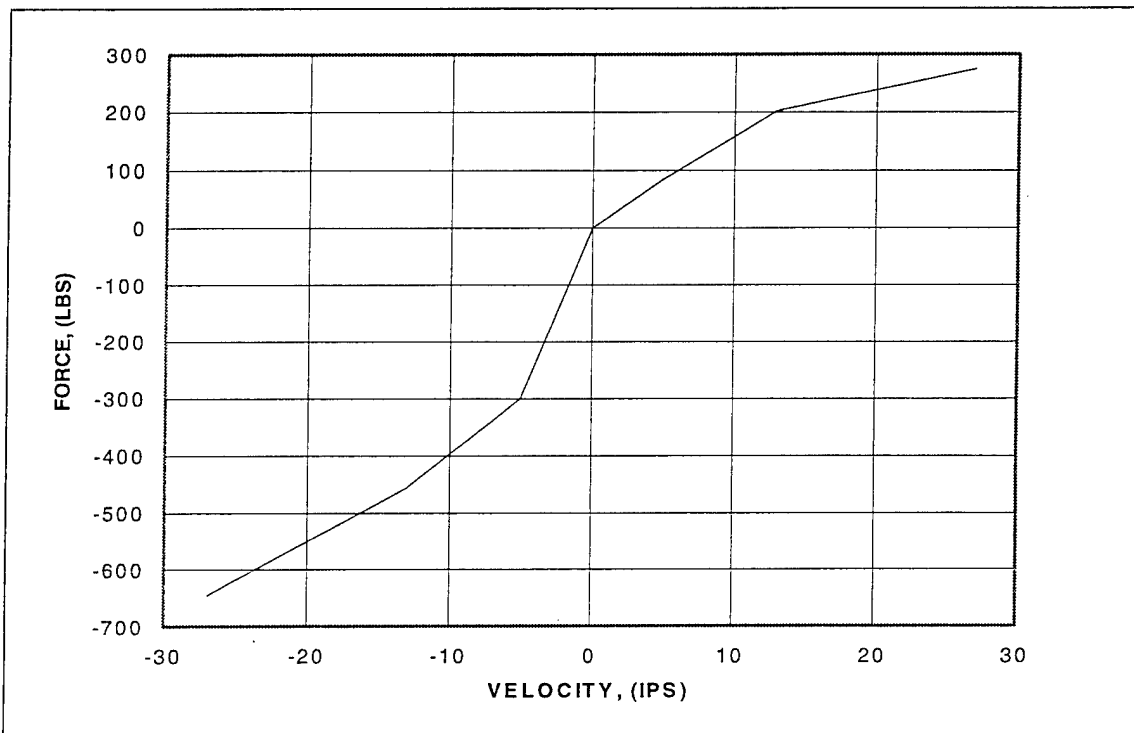

Figure 5.3.2-4- NEWAY Suspension Damper Characteristics

Table 5.3.2-1 lists the data provided by Michelin for the performance of their 16.00R20 XZL LRM tire. **Figure 5.3.2-5** shows some of the pertinent geometric characteristics of the vehicle design. All of these characteristics were combined into the VEHDYN2 input data file provided in **Figure 5.3.2-8**, at the end of this section. **Table 5.3.2-2** lists the results of the VEHDYN2 analyses, both at off-road rated payload and empty. This table lists the 6 watt limit velocity for the concept vehicle as well as the percent improvement in velocity over the baseline vehicle for each terrain file.

Table 5.3.2-1 - Michelin Tire Characteristics

INFLATION PRESSURE / HIGHWAY SPEED										C - C		M/S/S
LOAD PER	SPEED (MPH)									LOAD PER		
TIRE	55.9	49.7	40.4	31.1	24.9	18.6	12.4	6.2	0.0	TIRE	40.4	12.4
36,376										154	36,376	
26,191								144	107	26,191		
21,826							133	117	88	21,826		
18,188						125	110	96	71	18,188		
16,733					122	113	100	87	65	16,733		
16,292				120	117	110	97	84	62	16,292		70
15,785			117	116	113	107	94	81	61	15,785		65
15,124		113	112	110	109	102	90	78	58	15,124		59
14,550	110	109	107	106	104	97	86	74	55	14,550		54
14,330	107	107	106	104	102	96	84	74	54	14,330		52
13,228	99	97	97	96	93	87	77	67	49	13,228	80	44
12,125	90	88	88	87	86	80	70	61	44	12,125	65	35
11,023	81	80	80	78	77	71	62	54	39	11,023	55	30
9,921	71	71	70	70	67	62	55	48	35	9,921	49	26
9,370	67	67	65	65	62	59	51	44	32	9,370	46	25
8,818	62	61	61	59	58	55	48	41	29	8,818	44	22
8,267	58	57	57	55	54	51	44	38	26	8,267	39	20
7,716	54	52	52	5	49	46	41	35	23	7,716	36	19
7,165	48	48	48	46	45	42	36	32	22	7,165	33	17
6,614	44	44	44	42	41	38	33	28	19	6,614	28	15
6,063	39	39	38	38	36	35	28	25	17	6,063	25	13
5,512	35	35	33	33	32	30	25	22	15	5,512	22	12
4,960	30	30	28	28	26	25	22	19	13	4,960	19	9
DEFLECTION	2.55	2.57	2.59	2.61	2.65	2.78	3.04	3.35	4.10		3.24	4.78

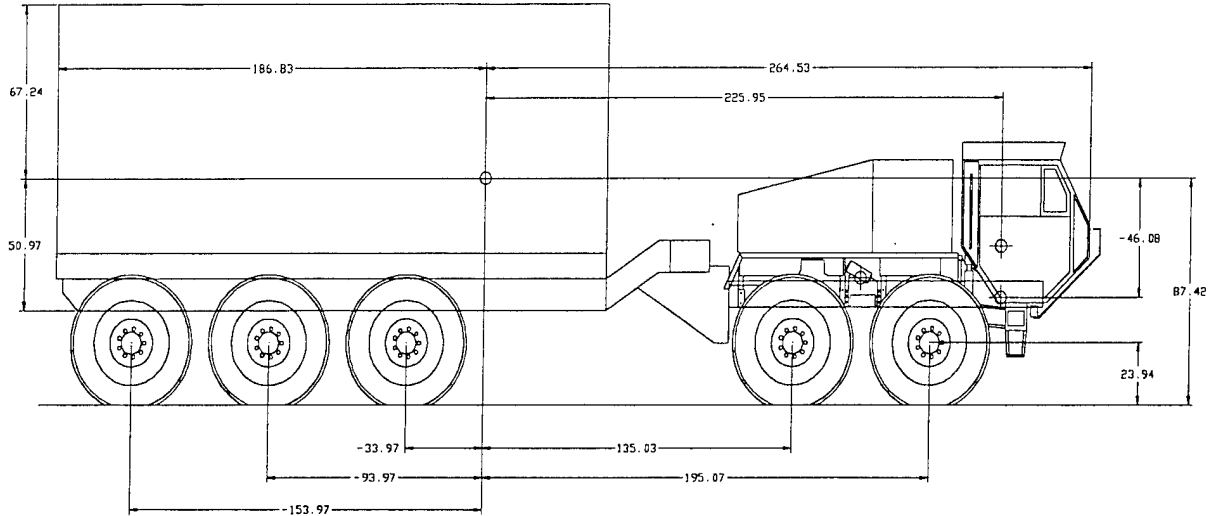

Figure 5.3.2-5 - Recommended LVSR Concept Geometry

Table 5.3.2-2 - Predicated Performance

Terrain File	RMS (in)	HYBRID C			
		EMPTY		LOADED	
		V_{6W}	+	V_{6W}	+
CHV06	0.19	>55	>239	>55	>29
CHV01	0.34	>55	>283	>55	>32
APG37	0.66	30.48	172	32.50	63
FTK34	0.86	32.20	437	28.03	95
APG09	1.01	19.00	313	18.30	37
LET05R	1.20	23.50	422	18.37	38
YPG04	1.81	12.77	122	11.82	68
APG29	2.17	15.22	262	14.02	162
LET07L	3.27	10.33	146	10.02	123
LET07R	3.49	9.88	141	8.93	108
LET16	4.00	8.80	117	5.68	35

Figure 5.3.2-6a graphically illustrates this predicted performance for the concept vehicle at off road rated payload conditions, while Figure 5.3.2-6b shows the same information for the vehicle without payload. Figures 5.3.2-7a and b show the same data as a percent improvement over the baseline vehicle ride quality performance for all terrain.

The predicted ride quality for the Recommended LVSR vehicle is, as shown in Figures 5.3.2-6 and 7, greatly improved over the baseline LVS (Mk48/14) for all terrain analyzed. Thereby, greatly improving the capability of the LVS under all off-road conditions while simultaneously providing significantly increased payload capacity.

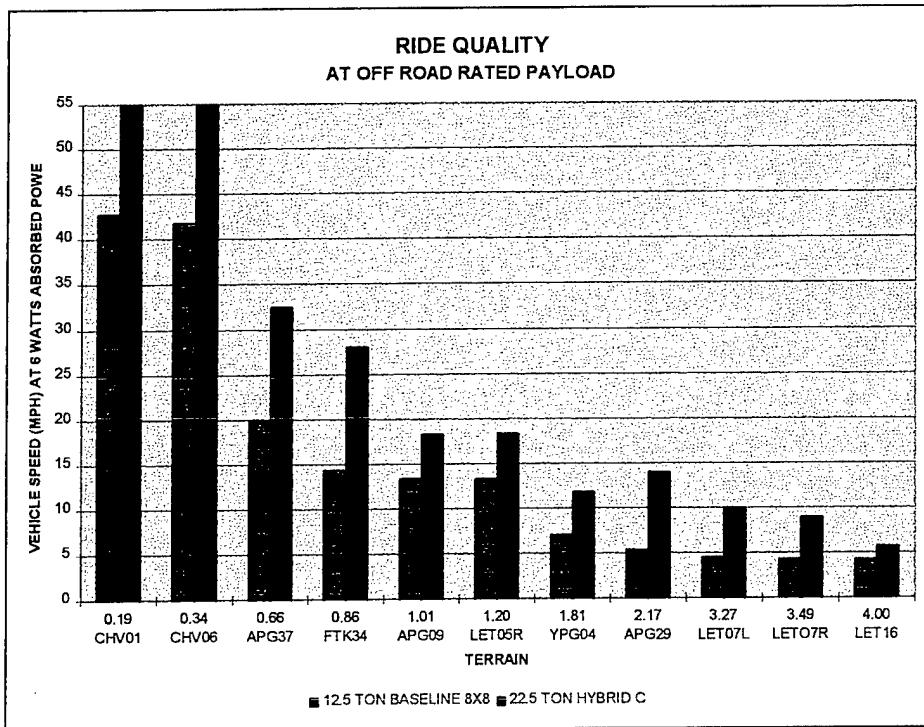

Figure 5.3.2-6a - Ride Quality Comparison (Rated Payload)

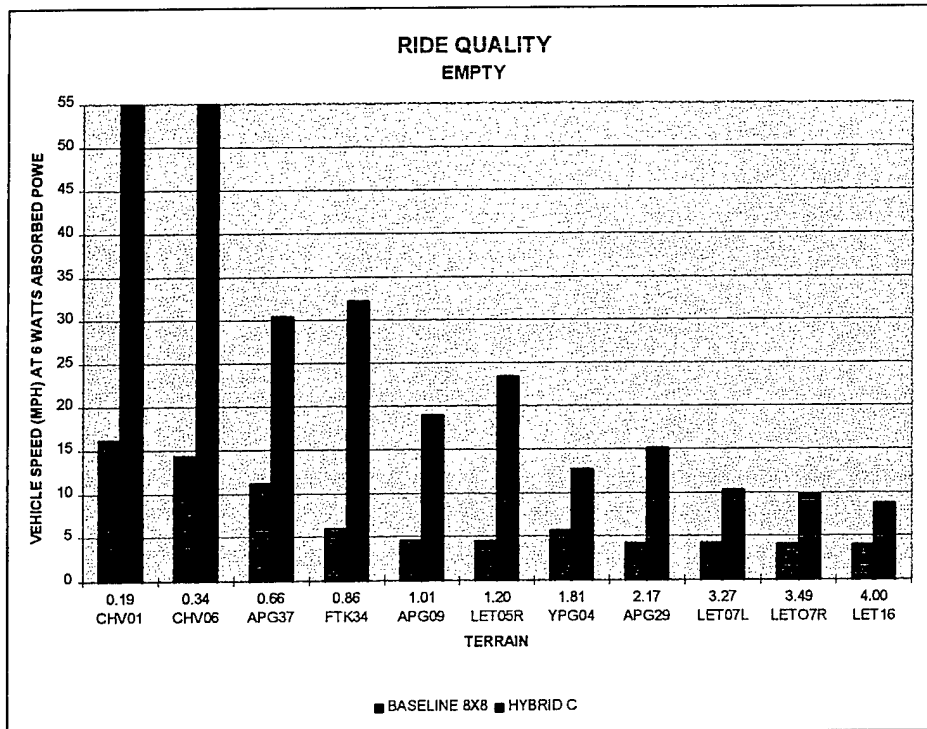

Figure 5.3.2-6b - Ride Quality Comparison (Empty)

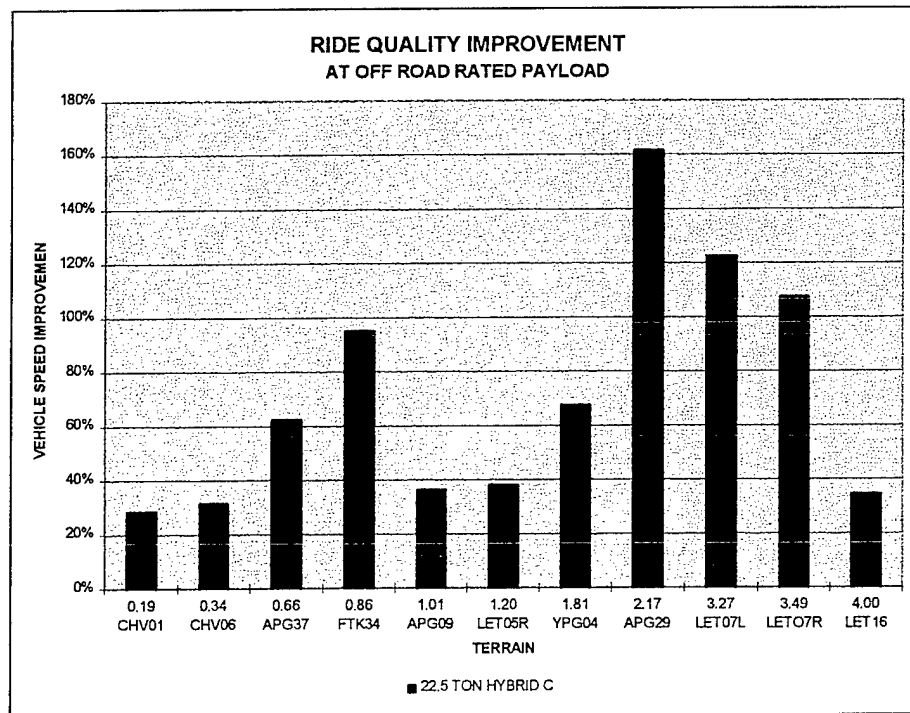

Figure 5.3.2-7a - Ride Quality Improvement (Rated Payload)

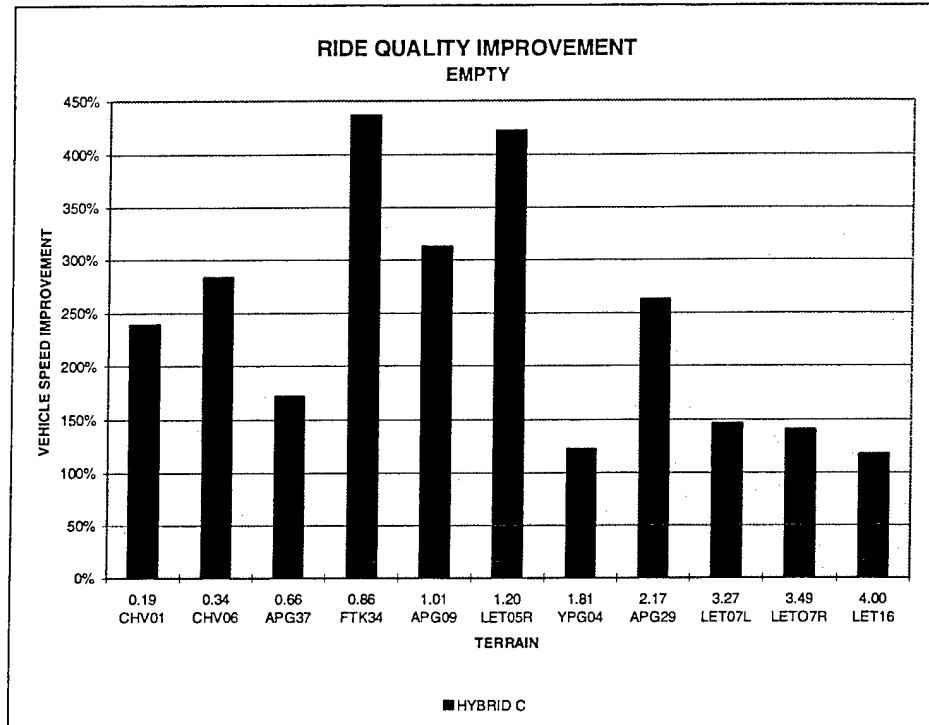

Figure 5.3.2-7b - Ride Quality Improvement (Empty)

LVS

LVS 10x10 HYBRID C (ROCKWELL/NEWAY) @ 22.5 TON PAYLOAD

```
1 3 3 0 0
20 0 0.000E+00 0.000E+00 0.000E+00 0.000E+00 0.000E+00 0.000E+00 1.378E+01
0.000E+00 7.900E-01 1.570E+00 2.360E+00 3.150E+00 3.940E+00 4.720E+00
5.510E+00 6.300E+00 7.090E+00 7.870E+00 8.660E+00 9.450E+00 1.024E+01
1.102E+01 1.181E+01 1.260E+01 1.339E+01 1.378E+01 1.403E+01
0.000E+00 8.300E+02 1.729E+03 2.558E+03 3.457E+03 4.150E+03 4.979E+03
5.672E+03 6.571E+03 7.263E+03 8.646E+03 9.891E+03 1.107E+04 1.231E+04
1.411E+04 1.570E+04 1.729E+04 1.971E+04 2.248E+04 4.748E+04
12 0 0.000E+00 0.000E+00 0.000E+00 0.000E+00 0.000E+00 0.000E+00 7.100E+00
-2.500E-01 0.000E+00 4.700E-01 1.100E+00 1.730E+00 2.350E+00 3.600E+00
4.850E+00 6.100E+00 6.850E+00 7.100E+00 7.350E+00
-2.500E+04 2.473E+03 3.140E+03 3.925E+03 4.907E+03 5.888E+03 7.850E+03
1.021E+04 1.570E+04 2.159E+04 3.942E+04 6.442E+04
5 0 0.000E+00 0.000E+00 0.000E+00 0.000E+00 0.000E+00 0.000E+00 3.800E+00
0.000E+00 1.050E+00 2.500E+00 3.800E+00 4.400E+00
0.000E+00 1.000E+02 1.500E+02 2.000E+02 2.500E+02
13 0 0.000E+00 0.000E+00 0.000E+00 0.000E+00
-7.717E+01 -3.819E+01 -2.835E+01 -1.890E+01 -9.450E+00 -3.540E+00 0.000E+00
3.540E+00 9.450E+00 1.890E+01 2.835E+01 3.819E+01 7.717E+01
-1.958E+03 -1.753E+03 -1.726E+03 -1.641E+03 -1.321E+03 -4.970E+02 0.000E+00
5.400E+01 1.930E+02 3.890E+02 4.200E+02 4.320E+02 4.860E+02
7 0 0.000E+00 0.000E+00 0.000E+00 0.000E+00
-2.700E+01 -1.300E+01 -5.000E+00 0.000E+00 5.000E+00 1.300E+01 2.700E+01
-6.440E+02 -4.570E+02 -3.000E+02 0.000E+00 8.500E+01 2.020E+02 2.750E+02
9 0 0.000E+00 0.000E+00 0.000E+00 0.000E+00
-1.000E+02 -1.927E+01 -9.630E+00 -3.400E+00 0.000E+00 3.400E+00 9.630E+00
1.900E+01 2.700E+01
-2.100E+02 -2.100E+02 -1.540E+02 -1.190E+02 0.000E+00 3.500E+01 1.260E+02
2.170E+02 2.170E+02
0 0 0 5 0 2
4.480E+00 4.134E+01
1.750E+02 6.449E+01 3 3
8.819300E+04 2.620531E+06
-2.215E+02 8.742E+01 4.306E+01 1.547E+02 -4.083E+02 3.645E+01
2.640E+01 1.036E+03 -2.640E+01 1.677E+01 3.180E+00 7.739E+03 1
2.640E+01 1.036E+03 -8.644E+01 1.677E+01 3.180E+00 7.739E+03 1
2.640E+01 1.739E+03 -2.554E+02 1.961E+01 3.190E+00 9.592E+03 1
2.640E+01 1.706E+03 -3.154E+02 1.962E+01 3.180E+00 9.558E+03 1
2.640E+01 1.618E+03 -3.754E+02 1.965E+01 3.150E+00 9.470E+03 1
1 1 1 0 0
2 1 1 0 0
3 2 2 0 0
4 2 2 0 0
5 2 2 0 0
```

Figure 5.3.2-8 - VEHDYN2 Input File