

REPORT DOCUMENTATION PAGE

Form Approved
OMB No. 0704-0188

Public reporting burden for this collection of information is estimated to average 1 hour per response, including the time for reviewing instructions, searching existing data sources, gathering and maintaining the data needed, and completing and reviewing the collection of information. Send comments regarding this burden estimate or any other aspect of this collection of information, including suggestions for reducing this burden, to Washington Headquarters Services, Directorate for Information Operations and Reports, 1215 Jefferson Davis Highway, Suite 1204, Arlington, VA 22202-4302, and to the Office of Management and Budget, Paperwork Reduction Project (0704-0188), Washington, DC 20503.

1. AGENCY USE ONLY (Leave blank)		2. REPORT DATE APRIL 2002	3. REPORT TYPE AND DATES COVERED TECHNICAL NOTE	
4. TITLE AND SUBTITLE SIMULATION OF THERMAL EFFECTS OF MICROWAVE RADIATION ON WARFIGHTERS			5. FUNDING NUMBERS	
6. AUTHOR(S) LARRY G. BERGLUND				
7. PERFORMING ORGANIZATION NAME(S) AND ADDRESS(ES) U.S. Army Research Institute of Environmental Medicine Kansas Street Natick, MA 01760-5007			8. PERFORMING ORGANIZATION REPORT NUMBER	
9. SPONSORING / MONITORING AGENCY NAME(S) AND ADDRESS(ES) U.S. Army Medical Research and Materiel Command Fort Detrick, MD 21702-5007			<div style="font-size: 2em; font-weight: bold;">20020513 067</div>	
11. SUPPLEMENTARY NOTES				
12a. DISTRIBUTION / AVAILABILITY STATEMENT Approved for public release; distribution unlimited			12b. DISTRIBUTION CODE	
13. ABSTRACT (Maximum 200 words) A thermal physiological computer model constructed using MathLab Simulink was adapted to predict the human thermal response to microwave beam radiation. The model simulates soldiers' responses to radio frequency radiation (RFR) from radar, communication and other sources. The model is operational but not complete or completely tested. The model's predictions include core and skin temperatures, skin blood flows, sweat rates, skin moisture, thermal sensation and discomfort. Simulations with the model were compared to human responses measured at Brooks Air Force Base and J.B. Pierce Laboratory from exposures to 100 and 450 MHz RFR beamed at their backs back while seated and wearing shorts. RFR intensities were 8 to 24 mw/cm ² in environments of 28 and 31C. For this frequency range the model assumes the core absorbs the RFR energy. The agreement between model and data was fairly good. It is recommended that this development work continue with comparison testing to human response data measured at higher frequencies. Human simulation capabilities that include thermal effects of microwave radiation could facilitate planning for complex and changing activities and equipment of the modern warfighter.				
14. SUBJECT TERMS human simulation, thermal-physiological response, comfort response, radio frequency radiation			15. NUMBER OF PAGES	
			16. PRICE CODE	
17. SECURITY CLASSIFICATION OF REPORT UNCLASS	18. SECURITY CLASSIFICATION OF THIS PAGE UNCLASS	19. SECURITY CLASSIFICATION OF ABSTRACT UNCLASS	20. LIMITATION OF ABSTRACT U	

USARIEM TECHNICAL REPORT T00-##

**SIMULATION OF THERMAL EFFECTS OF MICROWAVE RADIATION ON
WARFIGHTERS**

Larry G. Berglund

Biophysics and Biomedical Modeling Division

April 2002

U.S. Army Research Institute of Environmental Medicine
Natick, MA 01760-5007

TABLE OF CONTENTS

<u>Section</u>	<u>Page</u>
List of Figures	iv
Acknowledgments	v
Executive Summary.....	1
Introduction	2
Project objective.....	2
Background.....	2
Methods	2
Simulation model with microwave energy absorption	3
Thermal sensation	3
Results	4
Model testing	4
100 MHz	5
450 MHz	8
Conclusions	10
Recommendations.....	11
References	12
Appendix A	13
Appendix B	14

LIST OF FIGURES

<u>Figure</u>		<u>Page</u>
1	Three-compartment thermo-physiological model for microwave beam radiation	4
2	Thermal responses to 100 MHz RFR in a 31C environment	5
3	Local sweat rates in a 31C environment with 100 MHz RFR	6
4	Local skin blood flow in a 31C environment with 100 MHz RFR	6
5	Predicted skin moisture in a 31C environment with 100 MHz RFR	7
6	Comfort responses in a 31C environment with 100 MHz RFR	7
7	Skin and core temperatures in a 28C environment with 450 MHz RFR	8
8	Local sweat rates in a 28C environment with 450 MHz RFR	8
9	Comparison of comfort sensations with 450MHz RFR in 28C air	9
10	Comfort sensations from one subject receiving 450 MHz RFR in 31C air compared to predicted sensations	10

ACKNOWLEDGMENTS

The response data from human exposure to low and intermediate levels of 450 and 100 MHz microwave radiation measured by Dr. Eleanor Adair at Brooks Air Force Base and J.B. Pierce Laboratory is very much appreciated. The excellent data, which contains physiological and subjective responses, is particularly well suited for comparison to the predicted responses made by the simulation model, further it is likely the only such data in existence anywhere. The authors also thank Dr. Adair for sharing her insights and wisdom about thermal responses to microwaves acquired from extensive experimental observations.

EXECUTIVE SUMMARY

A thermal physiological computer model constructed using MathLab Simulink was adapted to predict the human thermal response to microwave beam radiation. The model simulates soldiers' responses to radio frequency radiation (RFR) from radar, communication and other sources. The model is operational but not complete or completely tested. The model's predictions include core and skin temperatures, skin blood flows, sweat rates, skin moisture, thermal sensation and discomfort.

Simulations with the model were compared to human responses measured at Brooks Air Force Base and J.B. Pierce Laboratory from exposures to 100 and 450 MHz RFR beamed at their back while seated and wearing shorts. RFR intensities were 8 to 24 mw/cm^2 in environments of 28 and 31C. For this frequency range the model assumes the core absorbs the RFR energy. The agreement between model and data was fairly good.

It is recommended that this development work continue with comparison testing to human response data measured at higher frequencies. Human simulation capabilities that include thermal effects of microwave radiation could facilitate planning for complex and changing activities and equipment of the modern warfighter.

INTRODUCTION

Project Objective: Develop a thermal physiological model using MathWorks Simulink to predict the human thermal response to low and moderate intensity microwave exposure.

Background

The energy exchange between a soldier and the environment is important to his or her energy balance and body temperature regulation. It affects comfort, well-being, physiological health, performance and endurance. The energy flows depend on a number of parameters of the environment and the individual, for example: air temperature, thermal radiation, wind, humidity, clothing insulation and metabolic energy production. Radio or microwaves from antennae, communication equipment, industrial machines and other devices are becoming another source of thermal energy in the environment.

Human thermal response to the environment without microwave radiation can be simulated with accuracy by various computer modeling programs at USARIEM. These physiological and environmental models are increasingly accepted and used to plan and ensure soldier health and effectiveness in increasingly complex and demanding tasks. Current (USARIEM) models do not have the capability to include microwave or radio frequency radiation (RFR) in their simulations. This ILIR project was undertaken to make a start at predicting responses in environments where microwaves are present.

Others have shown the feasibility of modeling RFR effects with simple models (Adair, Berglund, 1985,86,92). Until recently, model testing has been restricted to animal data however some human physiological and subjective data are becoming available for validity testing from work at the J.B. Pierce Laboratory and Brooks Air Force Base. This project develops a simulation model using MATHLAB SIMULINK programming tools and compares the results to measurements by Adair (1999, 2001) made at Pierce and Brooks on human exposures to low level of microwave radiation.

METHODS

A relatively simple but widely accepted multi compartment lumped parameter model (Gagge, 1971, 1986) was used for the adaptation. It is a simplification of other more complicated models and considers the person to be represented by two thermal compartments (nodes), one representing the skin and the other the body core. This is a reasonable model for neutral and warm environments with low to medium activity because blood flow distributes heat and temperature rather uniformly in each of these compartments. It is also a good model for comparison to the available experimental human data which is now limited to core and skin temperatures, local sweat and skin blood flow rates and maybe how they feel.

In this model all metabolism occurs in the core, the core loses heat passively by conduction to the skin and by respiration and actively by regulating blood flow to the skin compartment. The metabolism while behaviorally dependent is automatically increased to a limited extent with hypothermia by regulating muscle tension and shivering. In turn the skin receives the heat from the core and passively transfers it to the environment. When that is insufficient, the body can initiate regulated sweating and the powerful cooling effects of evaporation. Radio frequency radiation can pass through normal dry clothing and be absorbed by both the skin and core compartments. Absorption in tissue generally takes place in the first wavelength of penetration. At microwave frequencies of 10 GHz and higher the radiation's wavelength in air is short [$\lambda=c/f=(3 \times 10^{10})/(10 \times 10^9)=3 \text{ cm} \approx 1 \text{ inch}$] and the RF energy is absorbed in the skin or close to it. Frequencies of 300 MHz and less have a wavelength in air of 1m or more and for these frequencies the energy can be assumed to be absorbed by the core.

For this project a systems approach to model development was done using Simulink by MathWorks. Simulink (Dabney, 2001) is a computer language or modeling tool that facilitates the building of computer models using graphical block diagram notation and connectors to simulate dynamic systems. The programs visually look much like electrical circuit diagrams (Appendix A). The block diagram-connector notation reduces the time to prepare and test code, facilitates debugging, documentation and visualization of results. It also reduces the specific computer coding skills needed by the modeler/programmer. Further, the block diagram method also makes it easier to explain the code to others and for others to contribute to a system's development.

SIMULATION MODEL WITH MICROWAVE ENERGY ABSORPTION

After the 2 node Model was running in Simulink and verified, the microwave absorption features were added. The absorbed microwave energy (AMicro) was modeled in terms of incident power density (IPD, Watts/m²), the projected area (A_p) of the body that intercepts the radiation and the energy fractions absorbed (α), transmitted (τ) and reflected (ρ) by skin and core compartments as appropriate.

$$AMicro = \alpha * A_p * IPD$$

The method has also predicted reasonable results for squirrel monkeys (Berglund, 1983). Absorption is wavelength dependent so longer wave RFR will penetrate further before being absorbed. The model to date has been developed for beam mono-frequency microwave radiation. For beam radiation, the skin compartment is further divided into radiated and non-radiated compartments. A schematic representation of the model is shown in Figure 1.

THERMAL SENSATION

Important aspects of a human's responses to the environment are their thermal comfort sensations. These emanate from thermal and other sensors in the body and are generally proportional to physiological strains. The sensations can be a motivator for behavioral protective actions. The simulation model uses deviations in the predicted

skin and core temperature and skin moisture to predict the simulated person's thermal sensation and discomfort

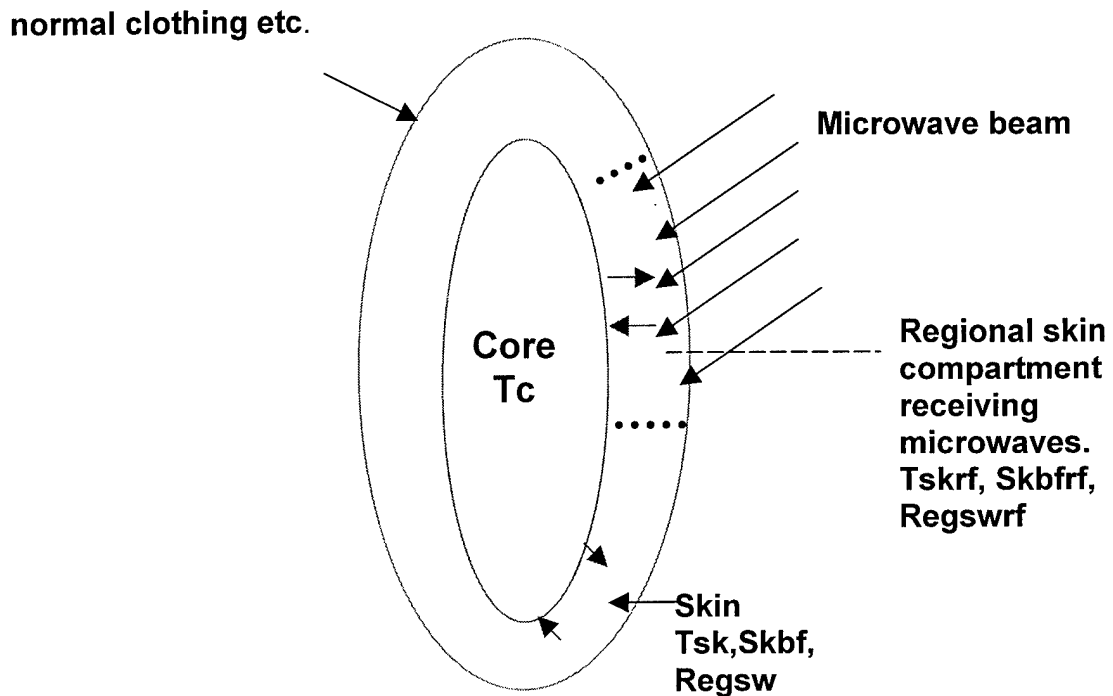

Figure 1. Three-compartment thermo-physiological model for microwave beam radiation.

RESULTS

MODEL TESTING

The Simulink simulation model was tested and exercised sufficiently to discover and correct bugs and instability conditions. It was then compared to human RFR response data measured by Dr Adair and colleagues from human experiments conducted at the J.B. Pierce Laboratory and at Brooks Air Force Base. Such response data included core and skin temperatures, skin blood flow, sweat rates and subjective responses measured under repeatable conditions and are very scarce.

To date the model has been compared to the responses of volunteers wearing shorts in uniform environments of 28 and 31°C experiencing beam radiation to the back while seated on a stool. The measurements were done in absorbing non-reflective chambers to eliminate diffuse RFR.

100 MHz

Figure 2 compares the predicted (T_c) to the measured core temperatures ($T_c \text{ exp}$) (mean of 7 subjects) for 100MHz radiation with an intensity of 8 mw/cm^2 ($80 \text{ w}/\text{m}^2$) to the back in a 31°C still air environment. The simulation assumed in this case that the core absorbed all of the radiation incident on the back. Figure 2 also shows the simulated skin temperatures for radiated (T_{skrfr}) and non-radiated (T_{sk}) skin. Comparable measured skin temperatures data were not available.

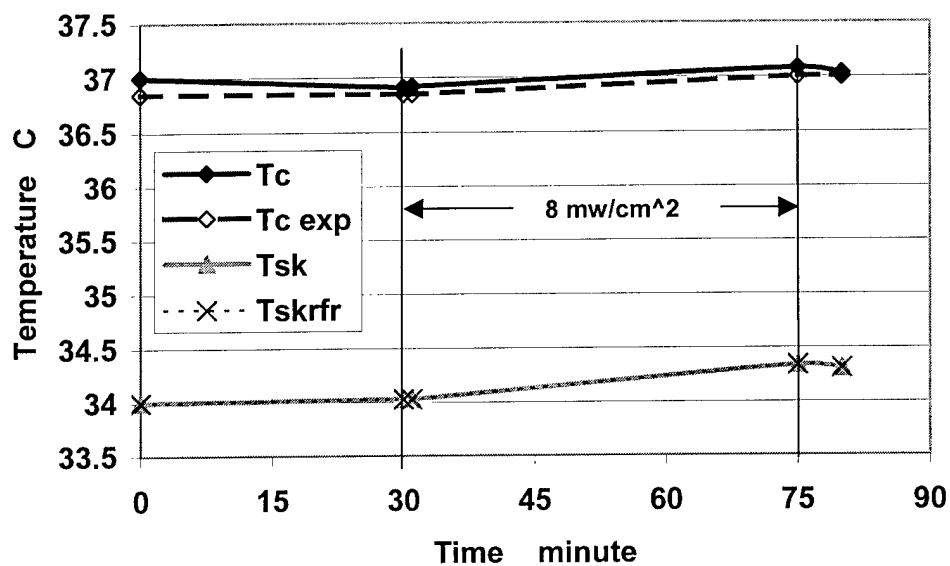

Figure 2. Thermal responses to 100 MHz RFR in a 31°C environment.

The simulated and measured sweat rates on the chest and back are compared in Figure 3. The shape of the responses for both simulated and measured conditions are similar except at the 30 minute mark. Encouraging is that the measured chest and back sweating rates are the same, indicating an absence of a radiation affects on the skin of the (radiated) back as assumed by the model for this frequency.

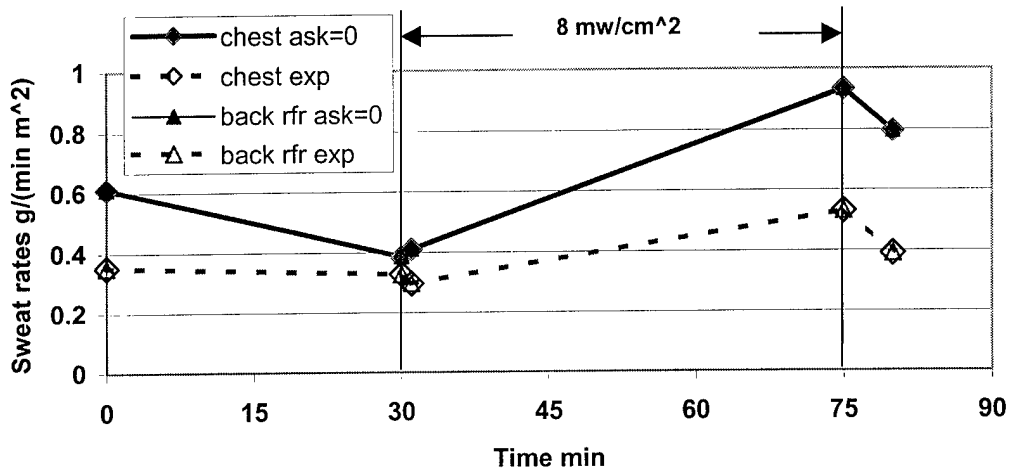

Figure 3. Local sweat rates in a 31C environment with 100 MHz RFR

Figure 4 compares the measured and simulated skin blood flows of the same condition. The measured local skin blood flows have the same response shape but are much higher than predicted. In this case it is suspected that laser Doppler blood measurements are too high as the reported values (chest exp, back rfr exp) appear excessive for the sedentary comfort condition.

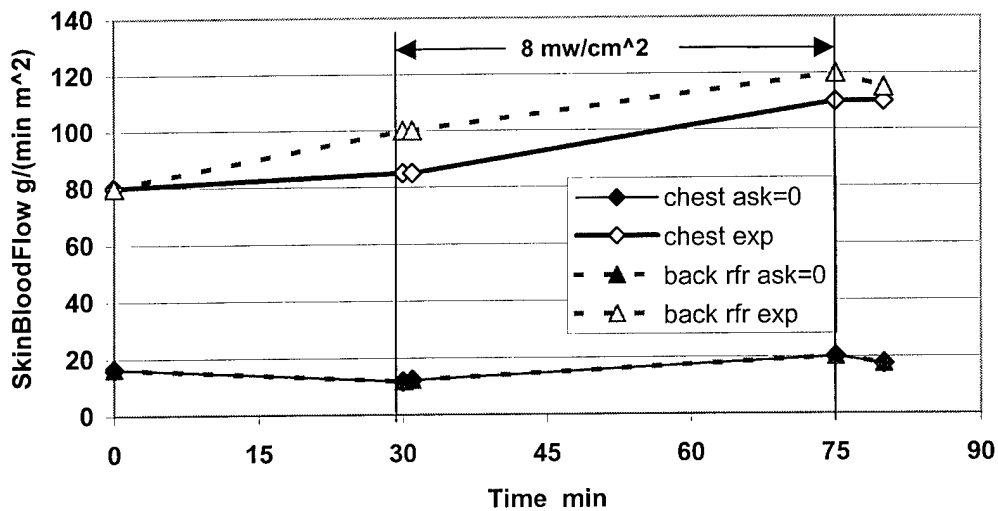

Figure 4. Local skin blood flow in a 31C environment with 100 MHz RFR.

The simulated skin moisture levels for the radiated (rfr) and non-radiated areas of the skin are displayed in Figure 5. Skin moisture is expressed here in terms of skin wettedness (wet) which is the fraction of skin covered with water to account for the evaporation rate. Measured skin wettedness levels were not available for comparison.

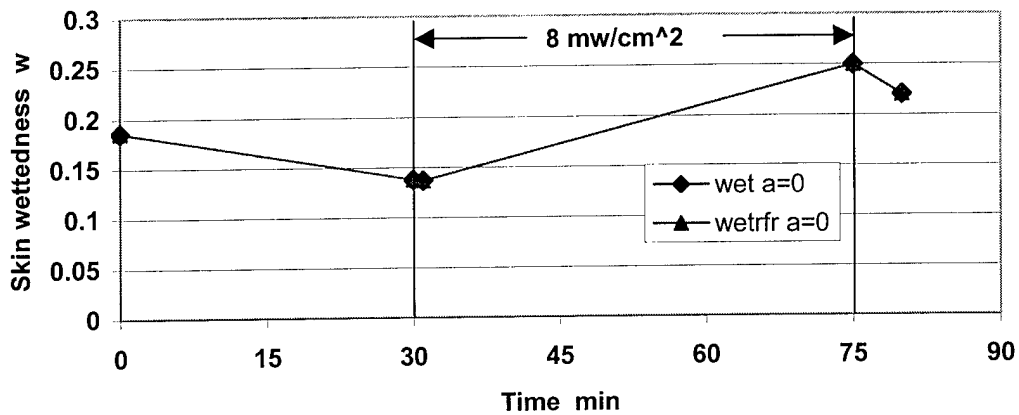

Figure 5. Predicted skin moisture in a 31C environment with 100 MHz RFR.

The simulated whole body thermal sensation (Tsens) and discomfort responses for the simulated person are given in Figure 6. The simulation indicates the RFR exposed person will feel warmer with increased thermal discomfort.

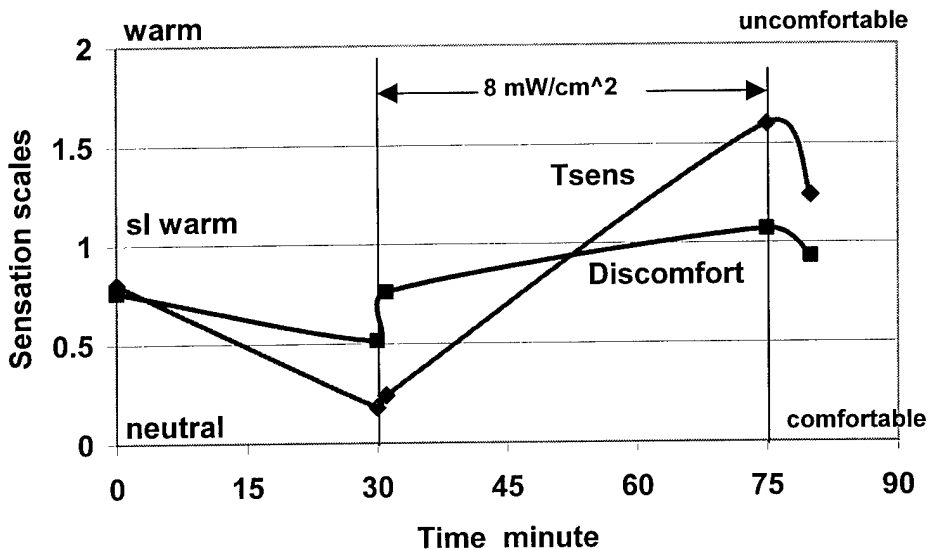

Figure 6. Comfort responses in a 31C environment with 100 MHz RFR.

450MHz

The following comparisons are for exposures to 450 MHz RFR in 28 and 31 C environments. The volunteer sat on a stool in shorts with his or her back facing the antenna or wave-guide. The climate controlled chamber had RFR absorbing non-reflective surfaces.

Figure 7 thru 9 are for the 28 C environment where the experimental values are the mean of 7 subjects. The experimental skin and core temperatures are compared to those predicted by the simulation model in Figure 7. The skin temperatures agree well at this 24 mw/cm² (240 w/m²) level as do the core temperatures, though the measured core temperature (Tc exp) after the radiation is unchanged and cooler than that predicted by the simulation model. The deviations between simulated and measured skin temperatures are always less than 0.5 C. The simulation was made assuming all the RFR energy was absorbed in the core (ask=0). This is an oversimplification for 450MHz RFR as discussed in the Background section, but the overall agreement was better than assuming it was all absorbed by the skin (ask=1).

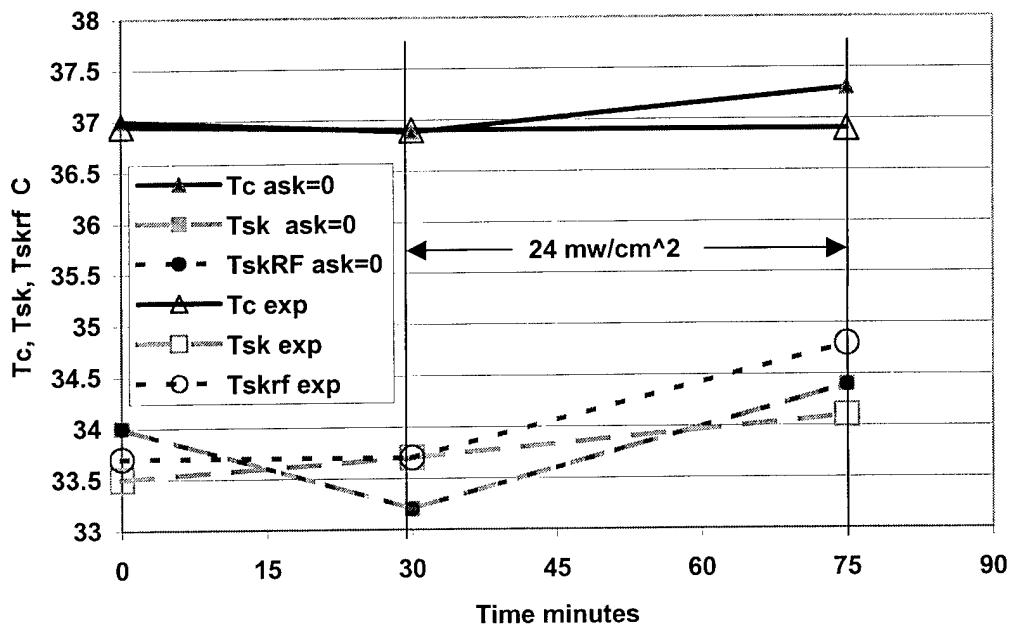

Figure 7. Skin and core temperatures in a 28C environment with 450 MHz RFR.

The sweat rates at the same conditions are compared in Figure 8. The agreement is fairly good expect for the back measurements (sweat rfr exp) measured before radiation started.

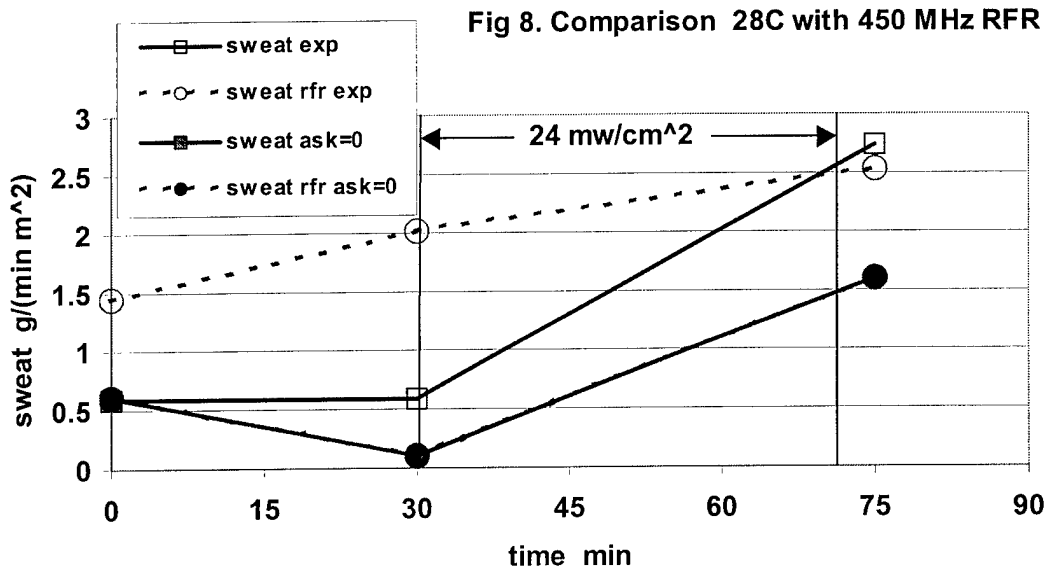

Figure 8. Local sweat rates in a 28C environment with 450 MHz RFR.

The mean whole body thermal sensations and discomfort judgments of the seven subjects are compared to predictions in Figure 9 for the 450 MHz RFR, 28C conditions. The agreement for discomfort is fairly good. The simulation over-predicted the warmth sensation felt by these subjects at the end of the RFR exposure, further indicating that

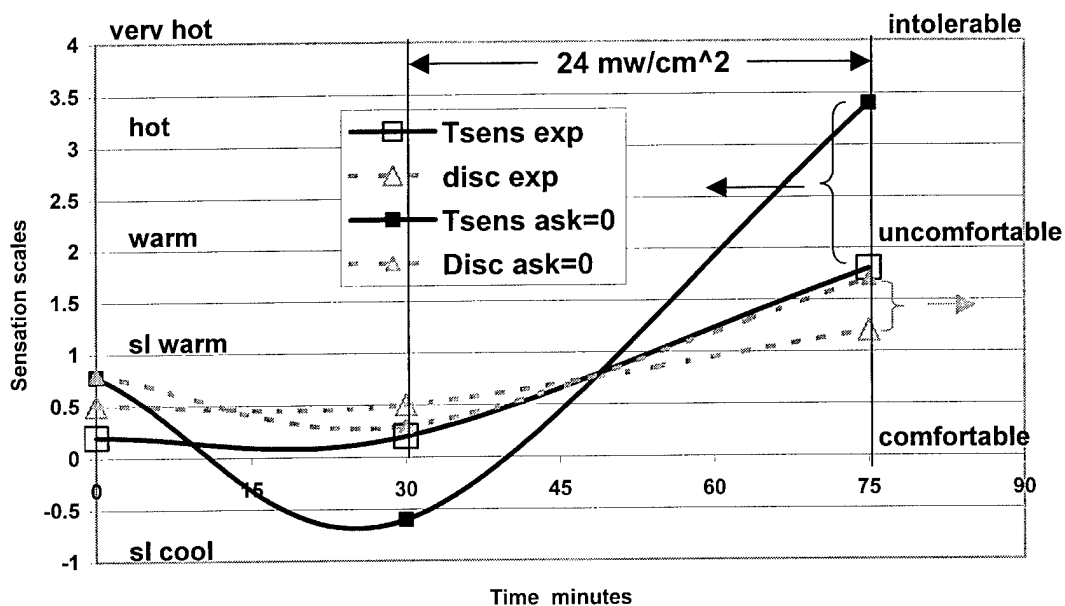

Figure 9. Comparison of comfort sensations with 450 MHz in 28C air.

less RFR was absorbed by the core than the model assumed for 450MHz.

The comfort responses of a single subject in a 31 C environment with 450 MHz RFR at 24 mw/cm² are compared to simulated predictions in Figure 10. The agreement is fairly good and indicates a person may be able to learn to feel the RFR heat sufficiently to behaviorally self protect from further exposure.

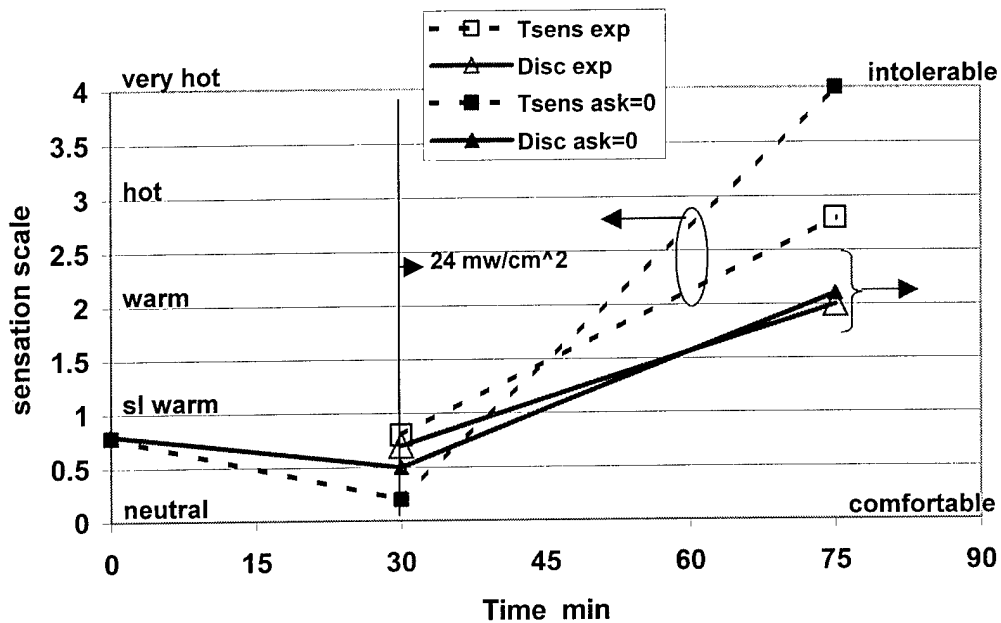

Figure 10. Comfort sensations from one subject receiving 450 MHz RFR in 31C air compared to predicted sensations.

CONCLUSIONS

This modeling report is a first attempt approach resulting from an ILIR project. The project assembled and tested a computer simulation model that predicts the thermal physiological and sensation responses of humans exposed to radio frequency radiation. The simulation model is operational. It rationally predicts core temperature, thermal sensation and discomfort and regional skin temperatures, skin blood flows, sweat rates, and skin wettedness levels for radiated and non-radiated skin areas of an exposure. Model prediction results were compared to recent human test data measured by Dr. Adair at Brooks Air Force Base and J.B Pierce Laboratory. The test data radiation was 100 and 450 MHz at intensities of 8 and 24 mw/cm² in environments of 28 and 31C.

The comparisons indicate that the human thermal response to 100 MHz beam radiation can be simulated with the assumption that all the RFR is absorbed by the body's core. This model assumption also worked fairly well for 450 MHz comparisons. At higher frequencies (>10 GHz) the model assumes RFR adsorption is confined to the skin area. Intermediate frequencies between 300 MHz and 10 GHz are assumed by the model to have adsorption in both core and skin tissues in relation to the calculated penetration depth for the frequency. The model's biophysics procedures for intermediate frequencies are uncompleted at this date.

RECOMMENDATIONS

It is recommended that the model evolution continue with comparison testing at frequencies higher than 450 MHz as data is found to be available. RFR is an increasing present energy component of the human environment. And human simulation models are an effective and expedient tool in planning activities where RFR may be present. Further it is recommended that protective clothing and other evasive action capabilities for the simulation model be encouraged and added.

REFERENCES

1. Adair, E. and Berglund, L., 1985. Comfort Heating with Microwaves: An Idea Whose Time May Have Come. *CLIMA 2000*, August, Copenhagen.
2. Adair, E. and Berglund, L., 1986a. On the Thermoregulatory Consequences of NMR Imaging. *Magnetic Resonance Imaging*, Vol. 4:321-333.
3. Adair, E. and Berglund, L., 1986b. Predicted Thermoregulatory Responses During Whole-Body MR Imaging. *Proceedings of Fifth Annual Society of Magnetic Resonance in Medicine*, August, pp.14-22.
4. Adair, E. and Berglund, L., 1992. Predicted Thermoregulatory and Comfort Consequences of Whole Body Magnetic Resonance Imaging. *Annals of the New York Academy of Sciences*, Vol. 649: 188-200, New York.
5. Adair, E., Kelleher, S., Berglund, L and Mack, G., 1999. Physiological and Perceptual Responses of Human Volunteers During Whole-Body RF Exposure at 450 Mhz. *Electricity and Magnetism in Biology and Medicine*, Edited by Bersani, Kluwer Academic/Plenum.
6. Adair, E, 2001. Data from Dr. Adair at Brooks Air Force Base by personal communication.
7. Berglund, L., 1983. Characterizing the Thermal Environment. In: *Microwaves and Thermoregulation*, Academic Press.
8. Dabney, J.B. and T.L.Harman. Mastering SIMULINK 4. Prentice Hall, 2001.
9. Gagge, A.P., Stolwijk, J.A.J. and Nishi, Y., 1971. An effective temperature scale based on a simple model of human regulator response. *ASHRAE Transactions* 77:247.
10. Gagge, A. P., Fobelets, A., and Berglund, L., L., 1986. A Standard Predictive Index of Human Response. *ASHRAE Transactions*, Vol. 92(2).

Appendix A

The simulation model in Simulink

November 8, 2001

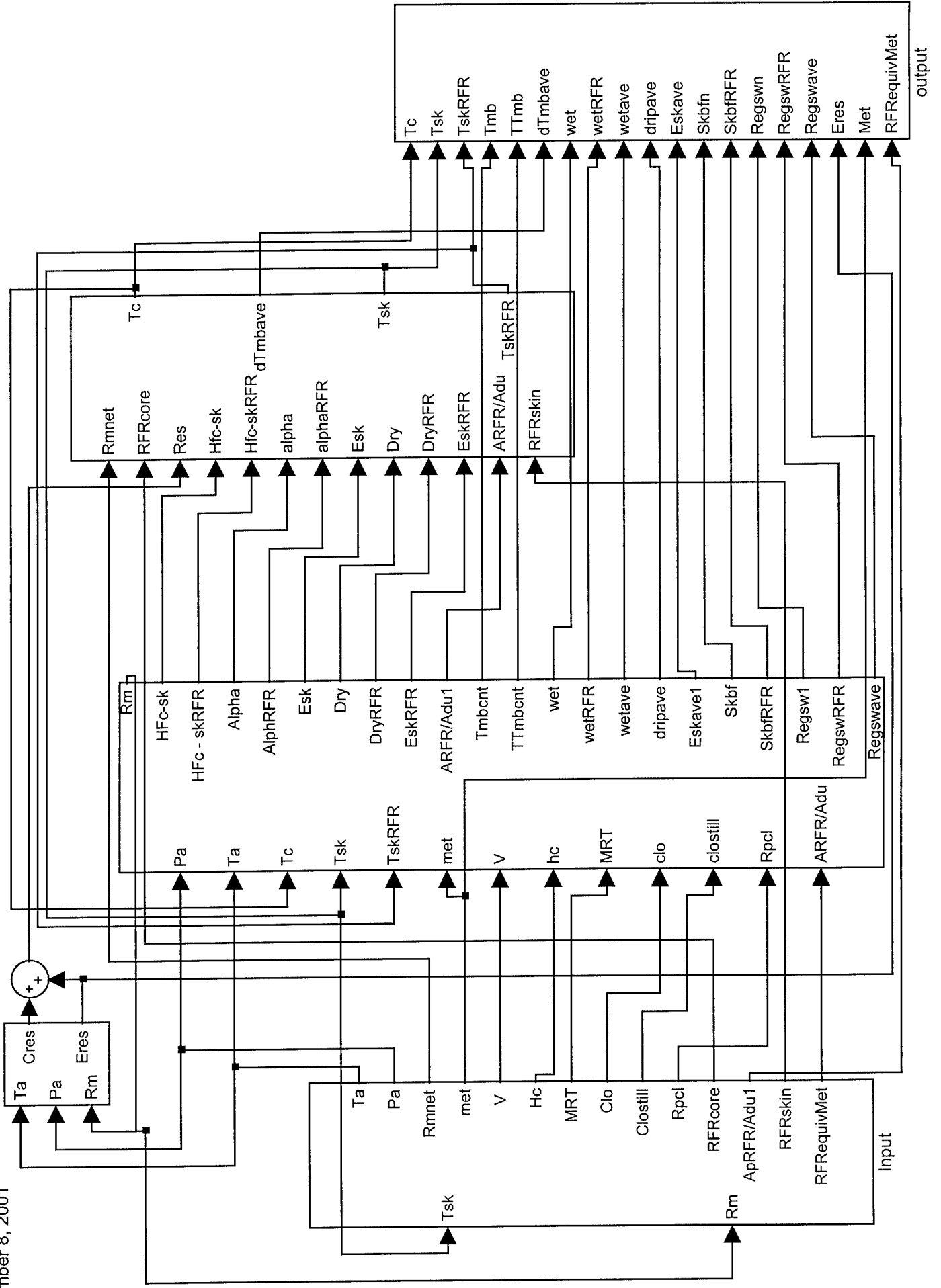

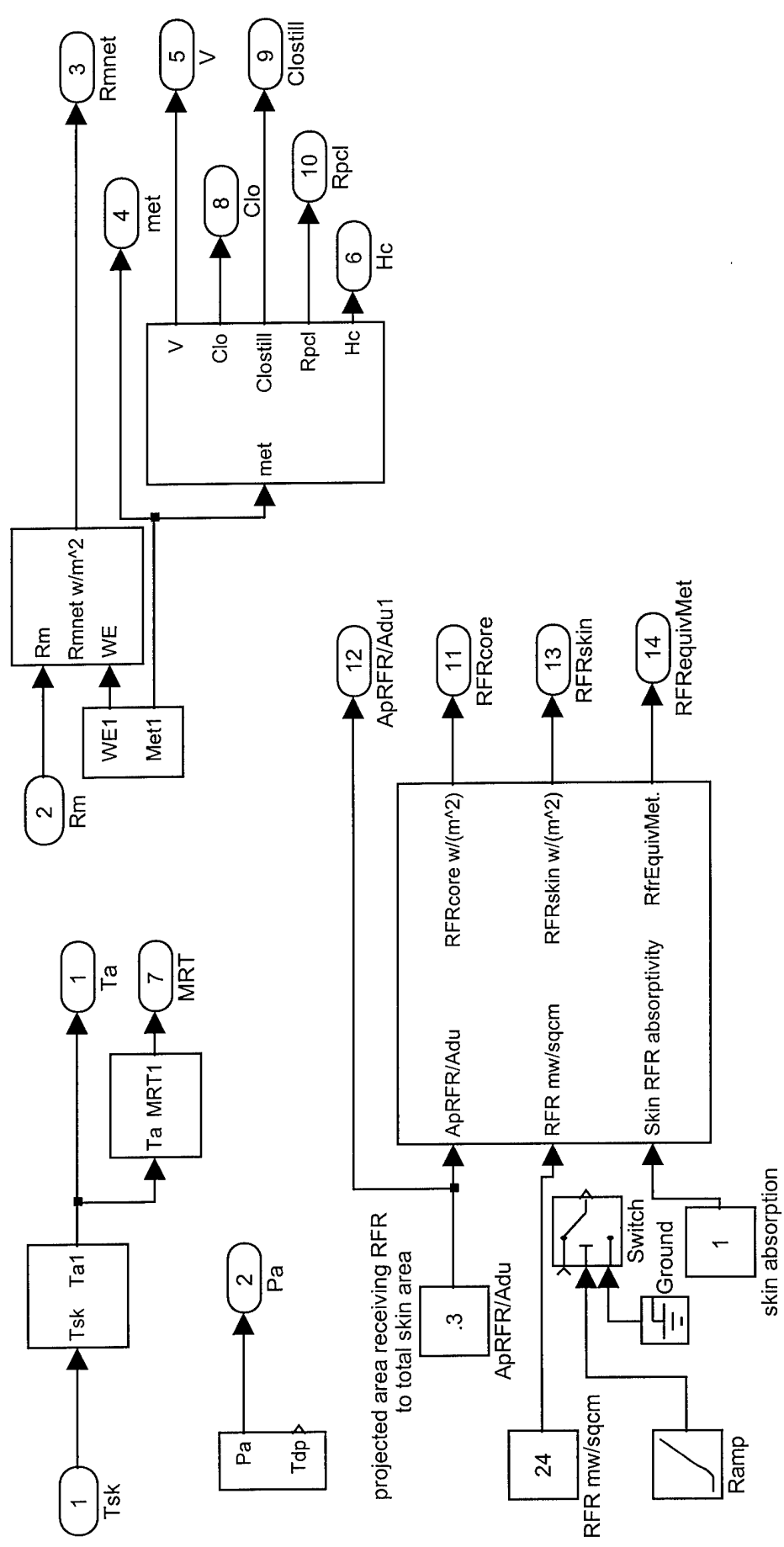

Feedback for Ta=MRT simulations

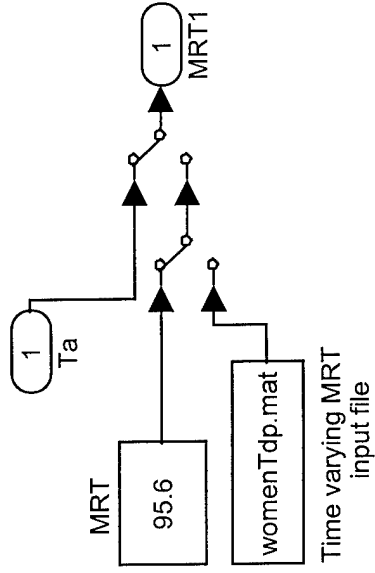

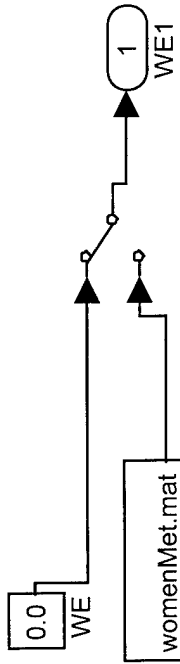

Time varying work efficiency WE

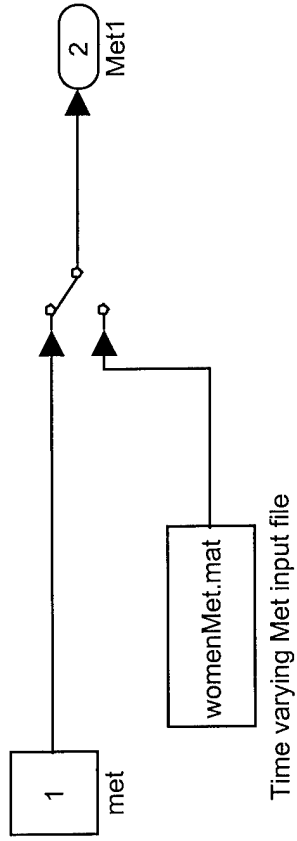

Time varying Met input file

Assume striking RFR not absorbed by skin is absorbed by core

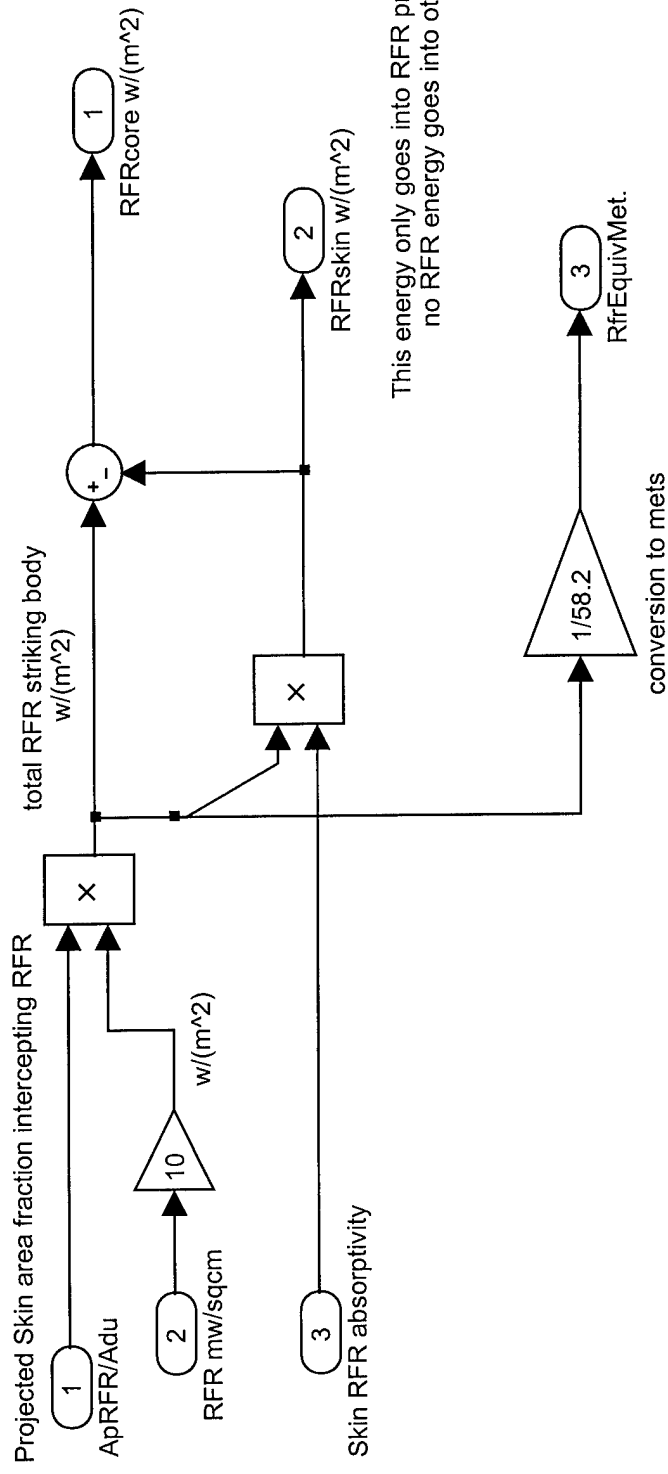

This energy only goes into RFR projected area fraction of skin
no RFR energy goes into other skin compartment

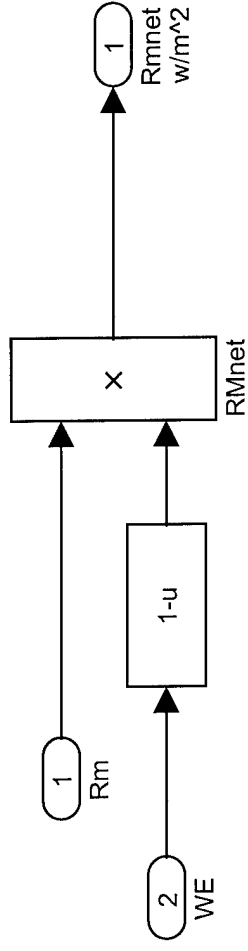

Thermodynamic work efficiency

$$\begin{aligned}
 R_{mnet} &= R_m - \text{work} \\
 \text{but } WE &= \text{work}/R_m \\
 \text{so } R_{mnet} &= R_m - WE \cdot R_m \\
 \text{or } R_{mnet} &= R_m \cdot (1 - WE)
 \end{aligned}$$

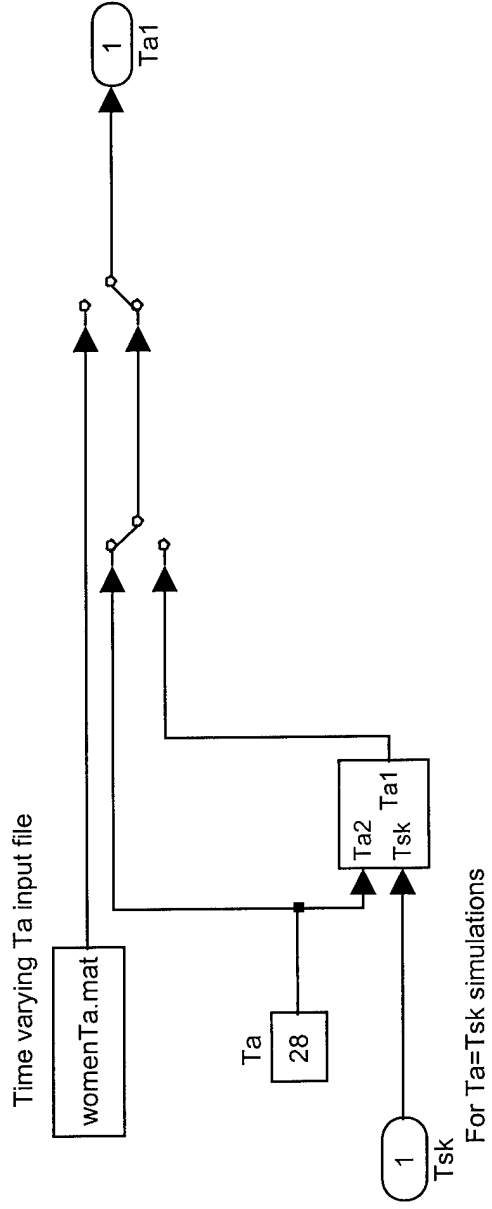

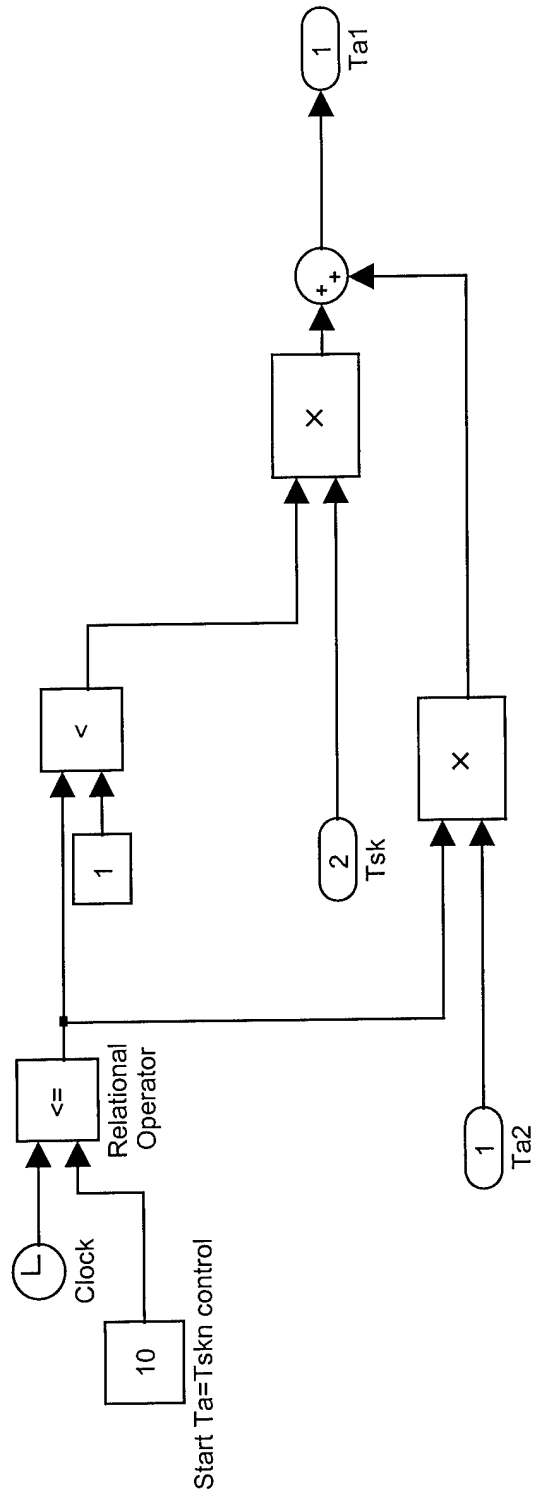

Humidity input

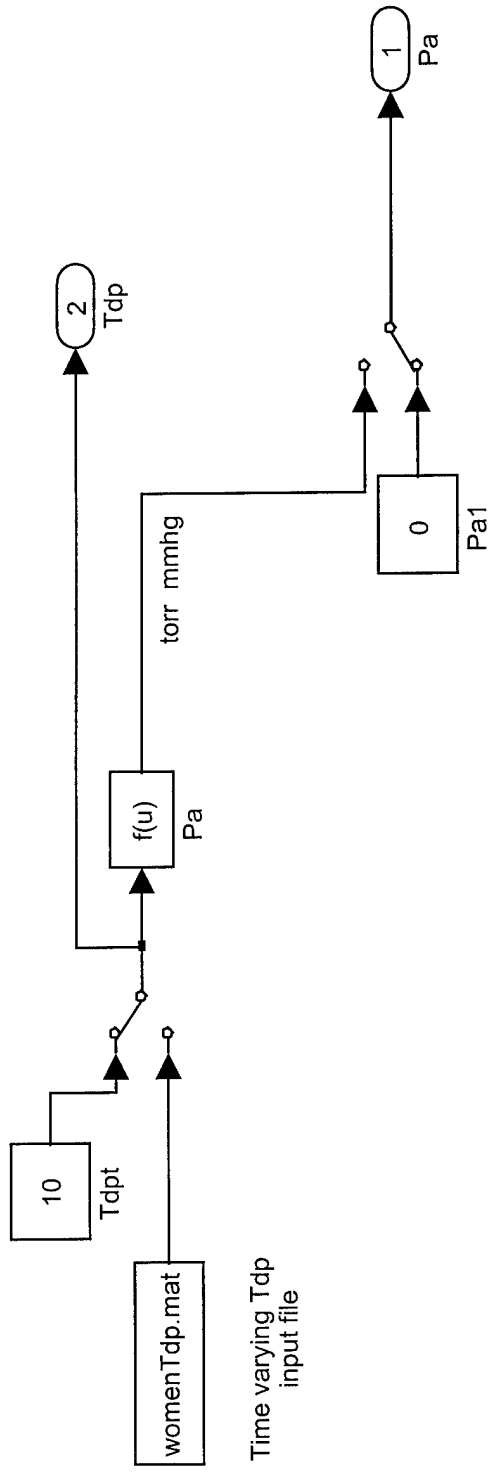

Time varying Tdp
input file

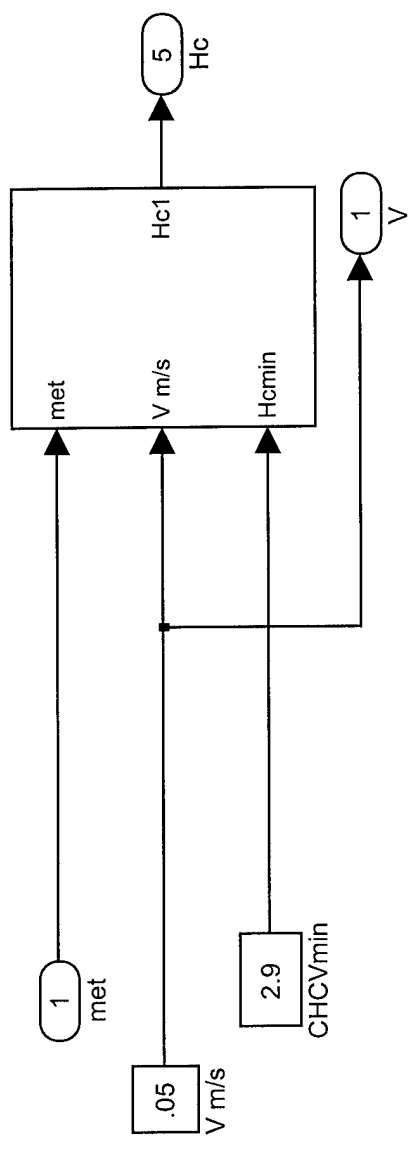
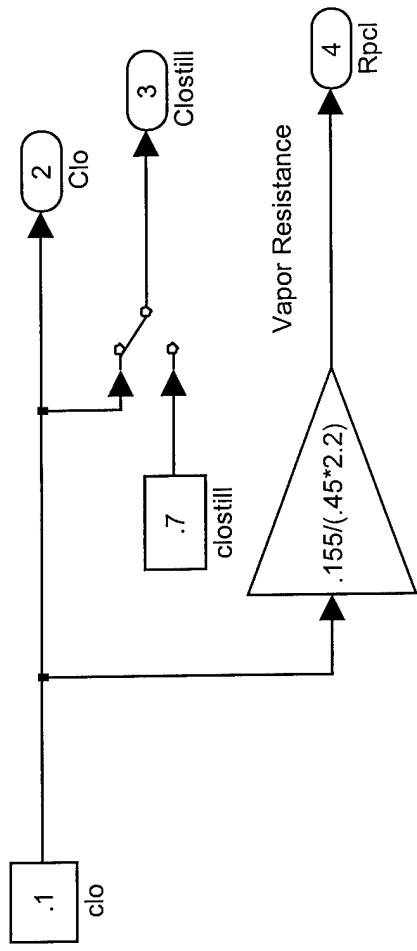

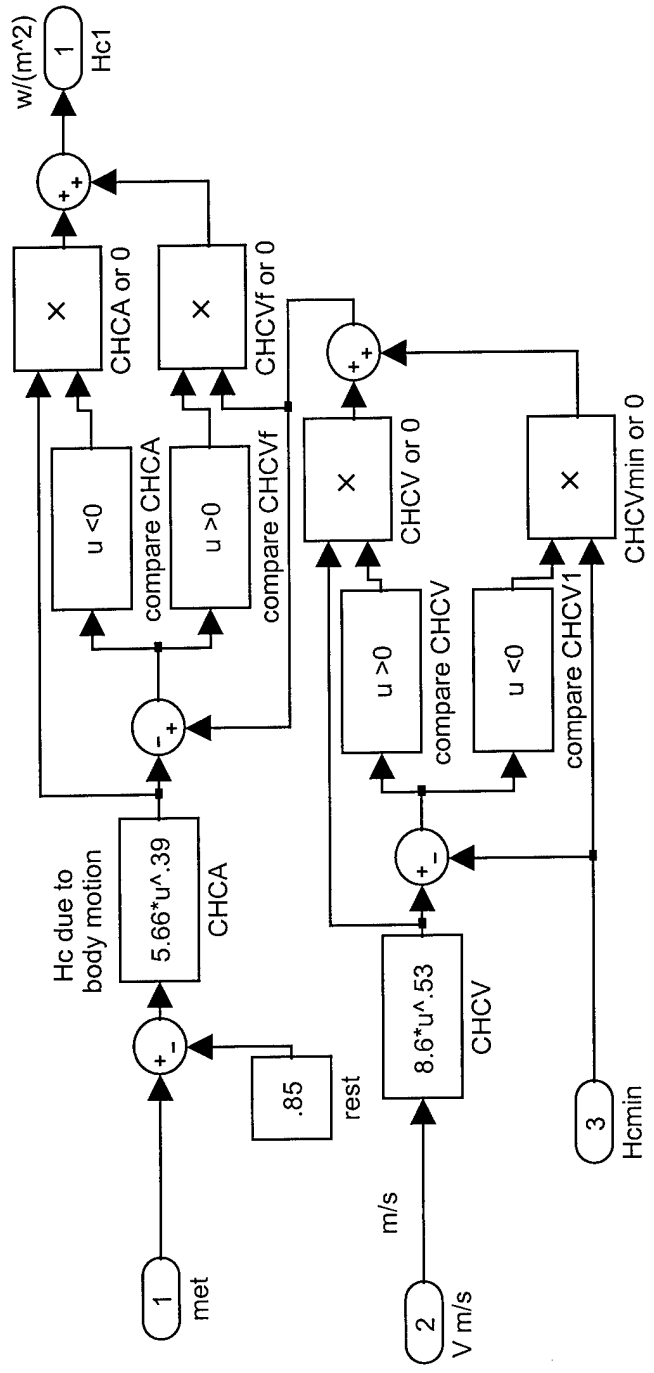

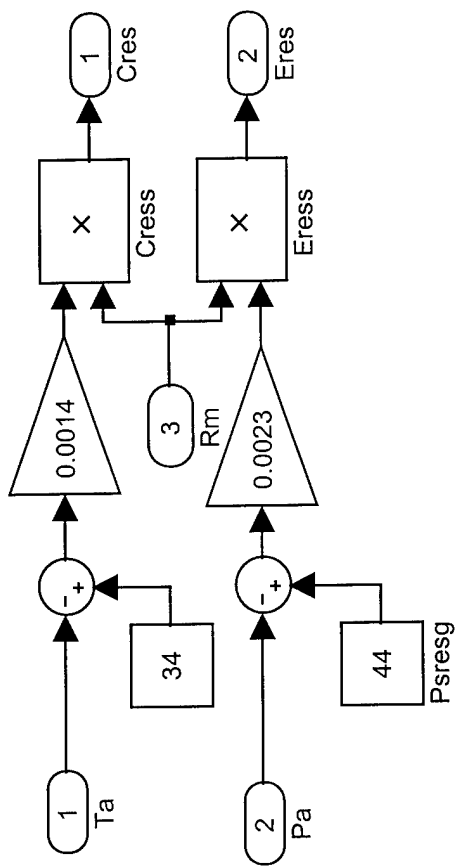

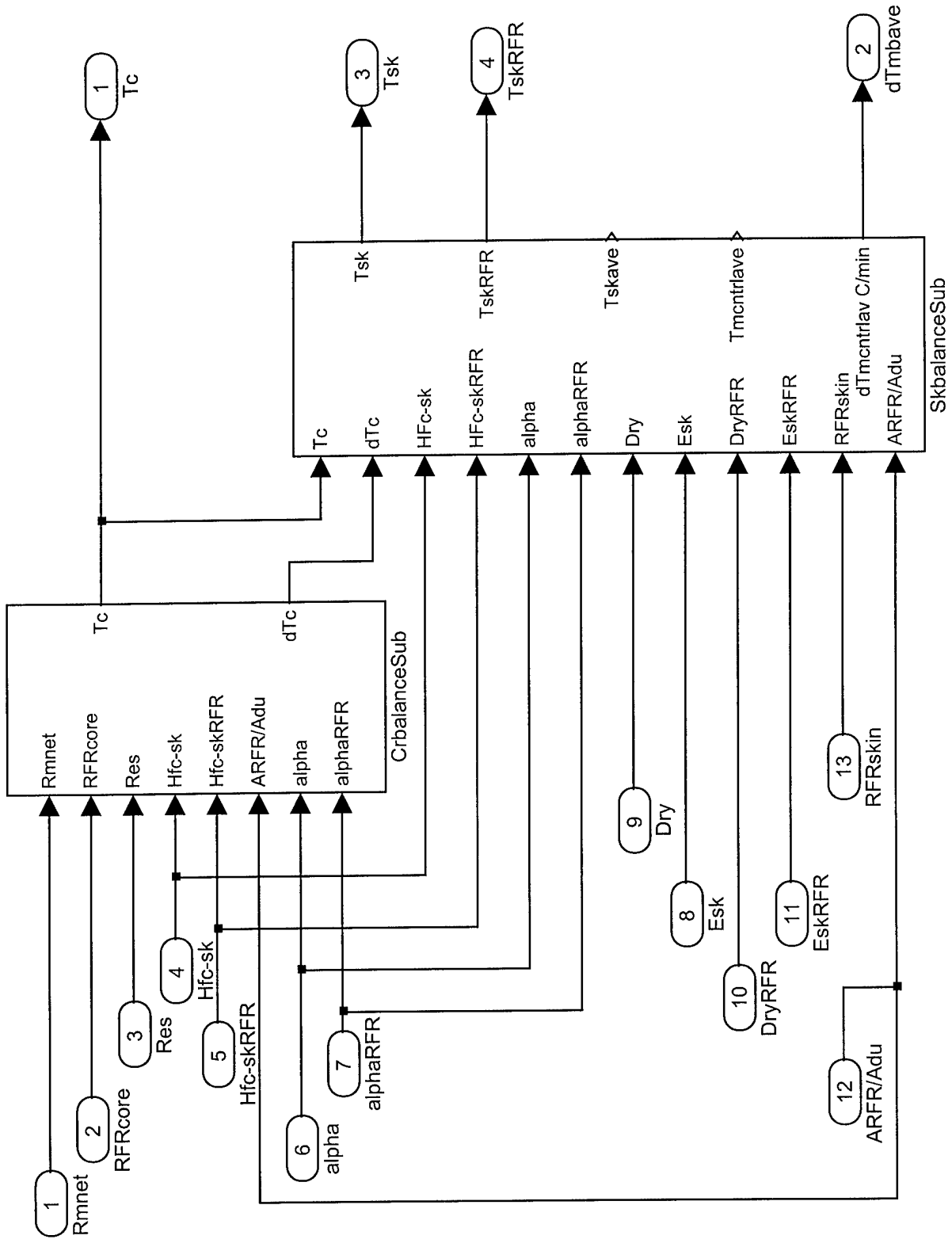

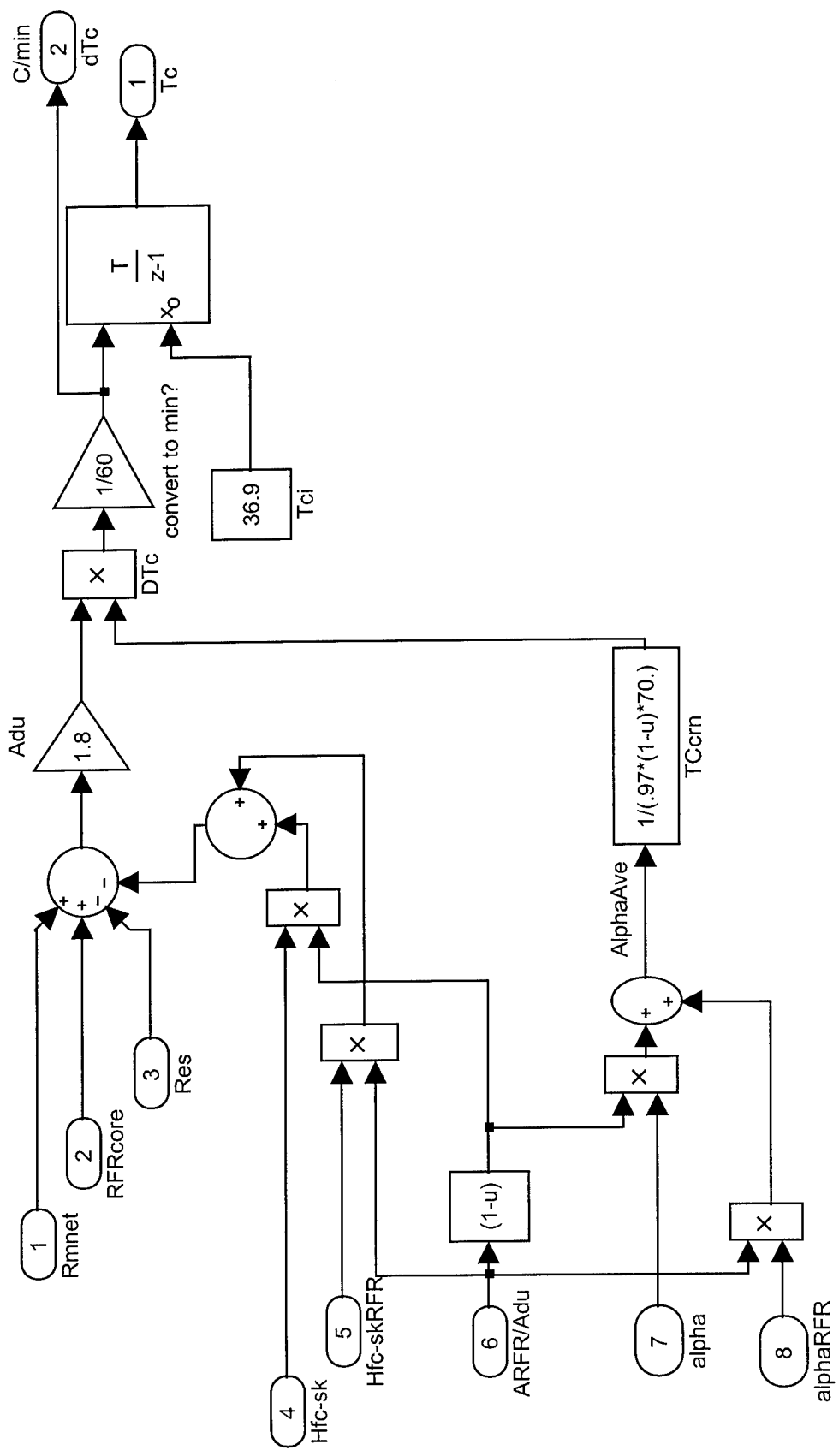

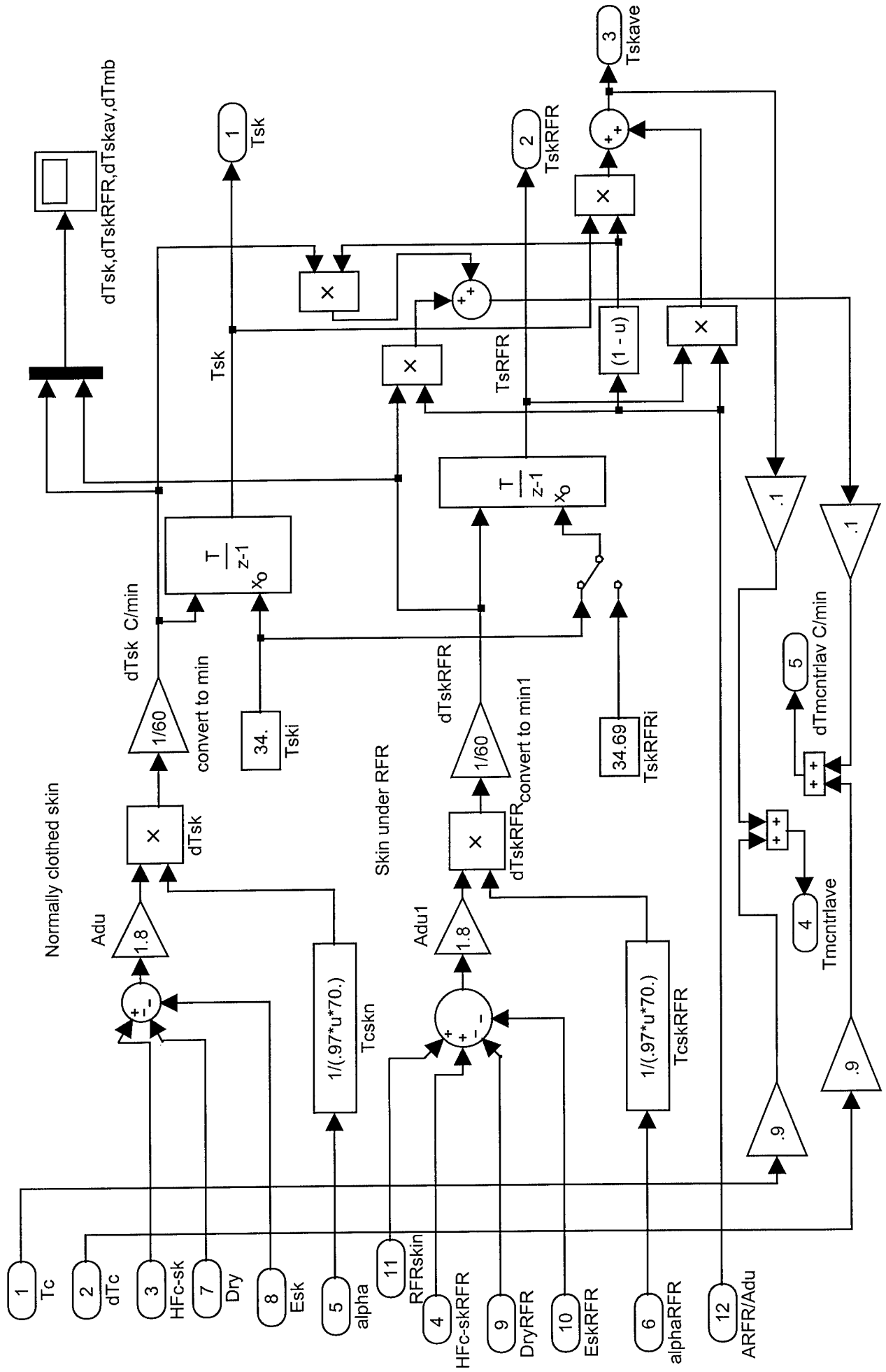

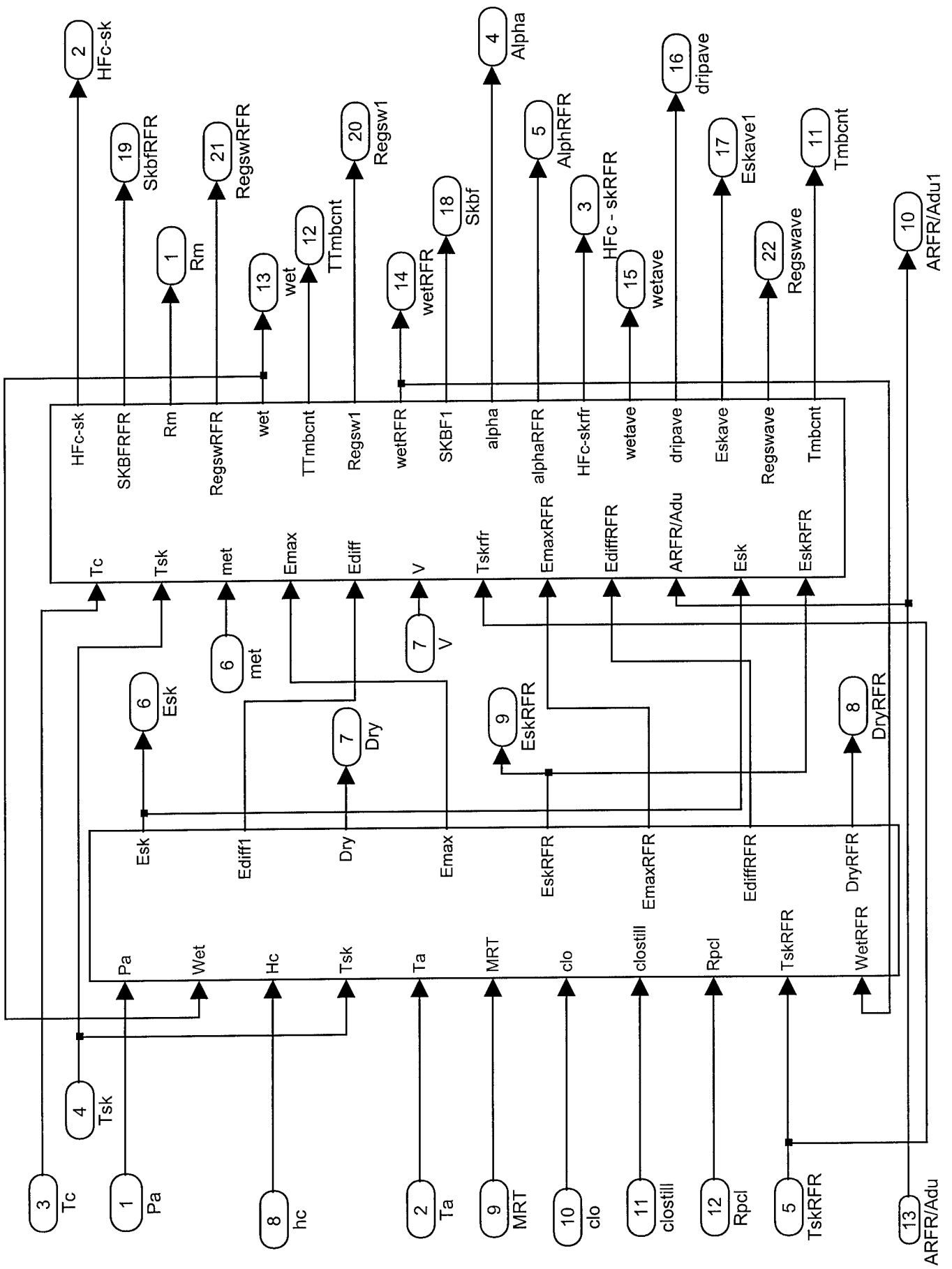

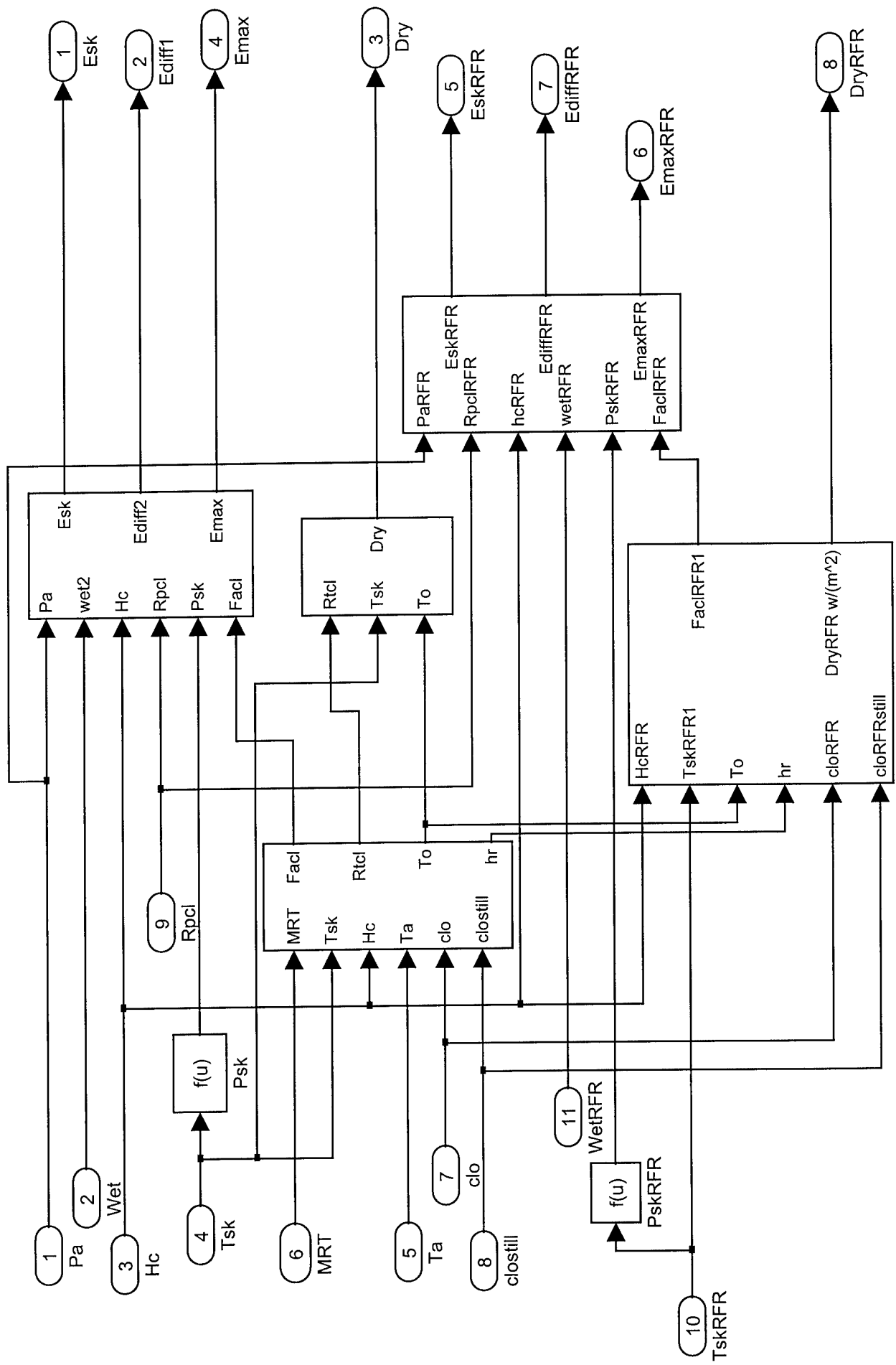

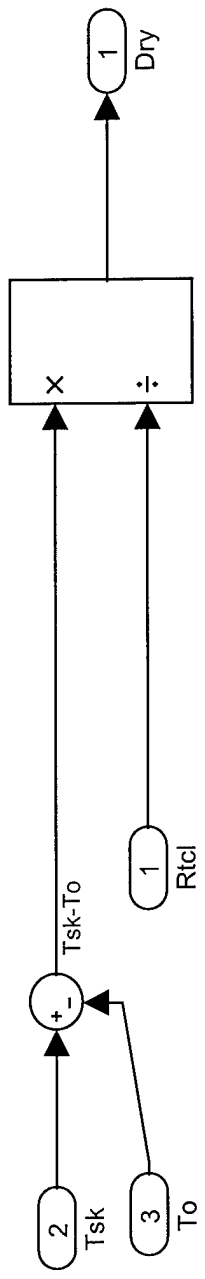

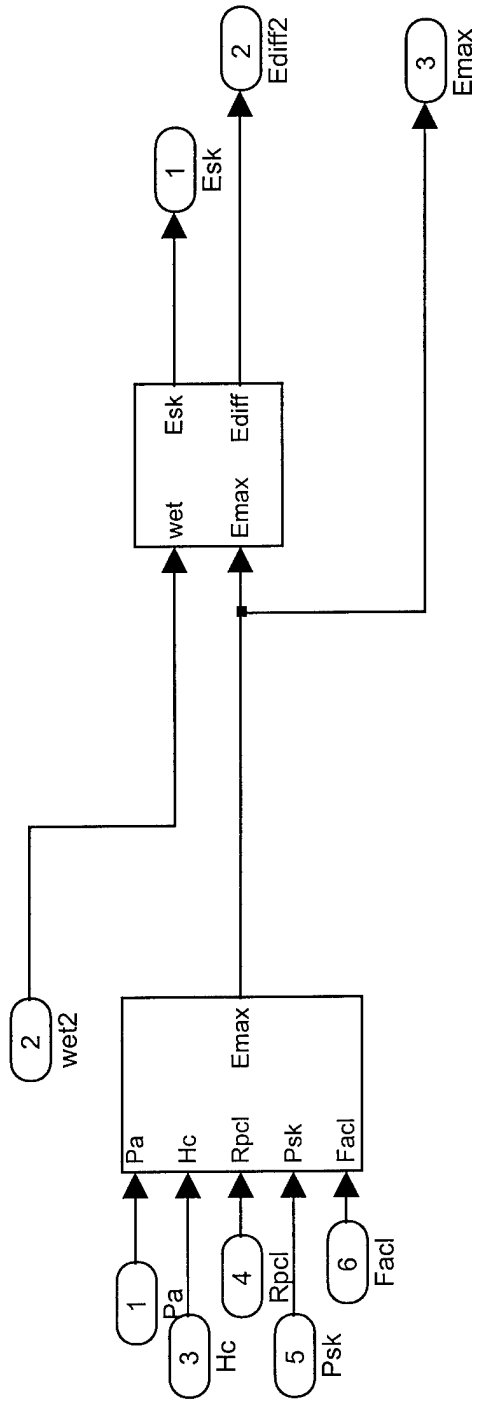

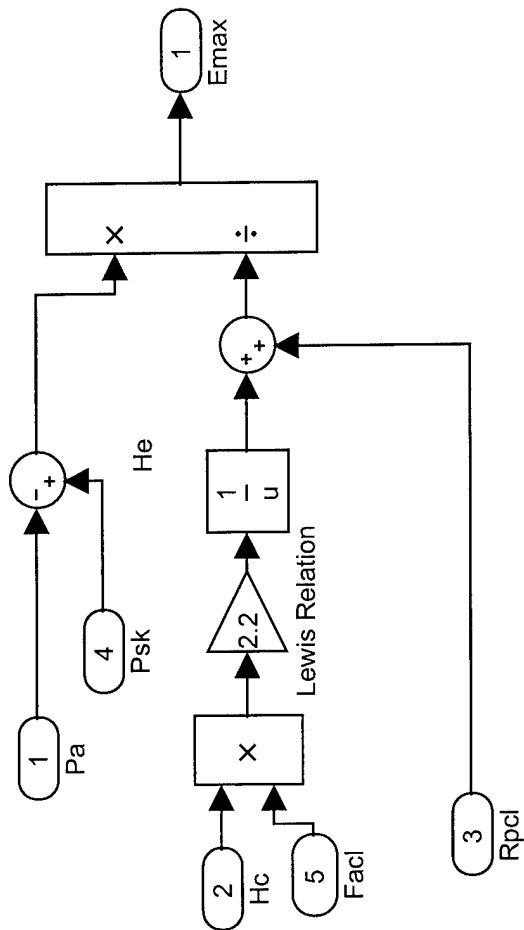

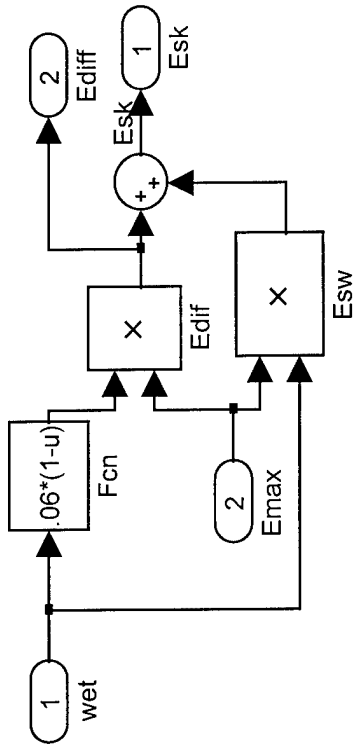

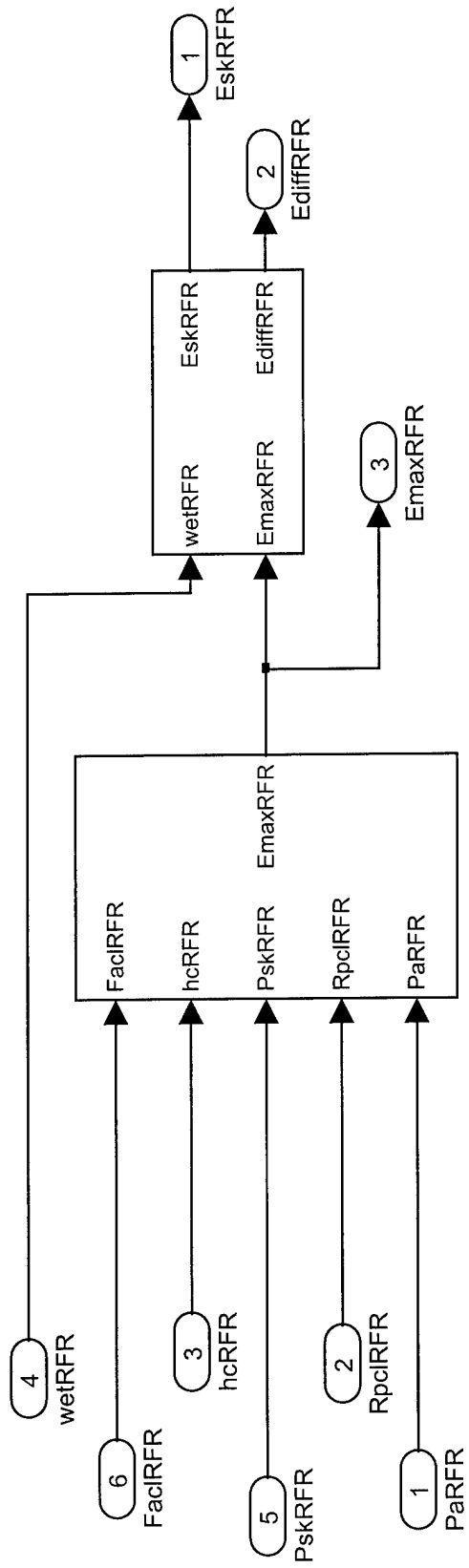

evaporation under clothing

????? Also check on wetc

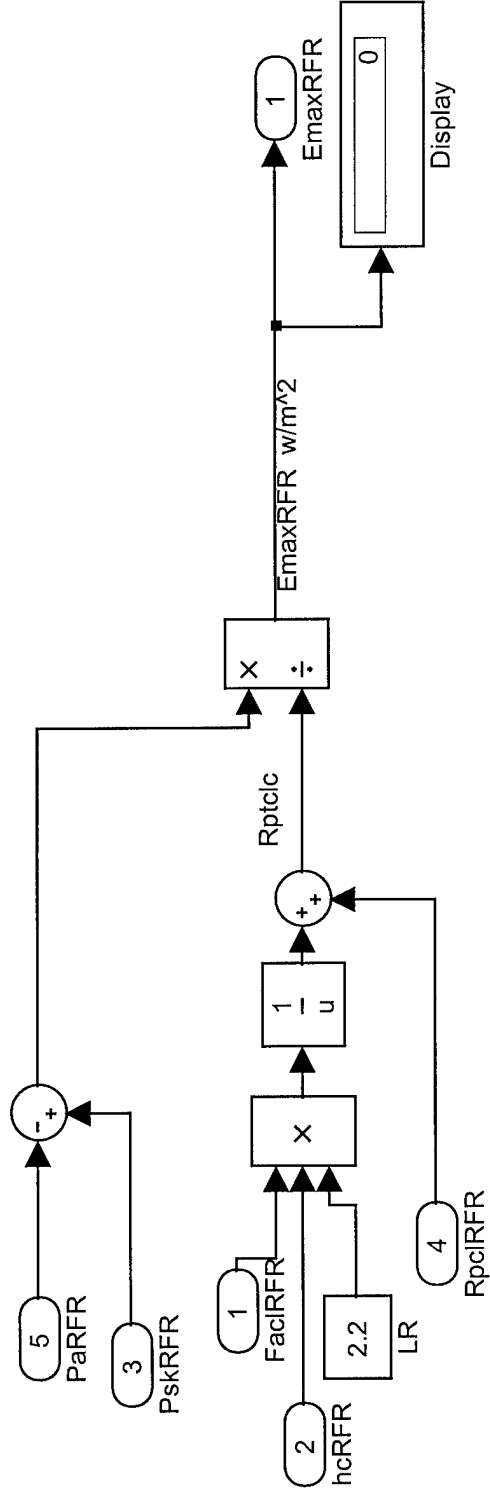

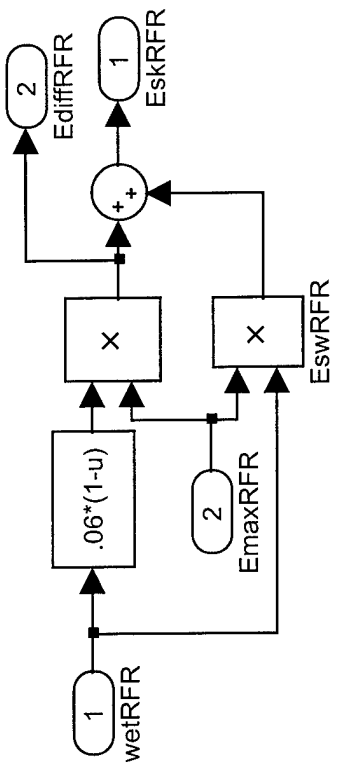

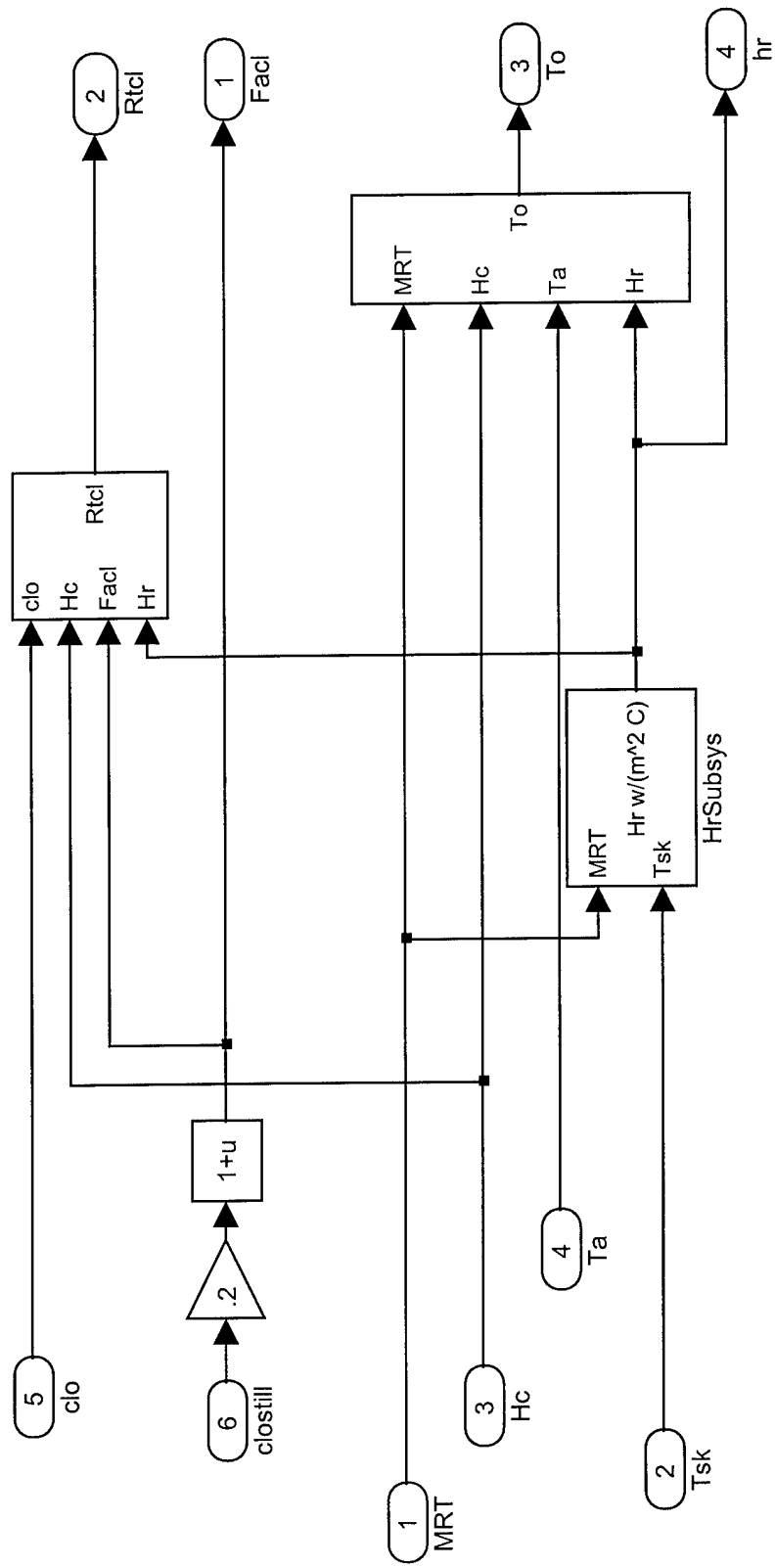

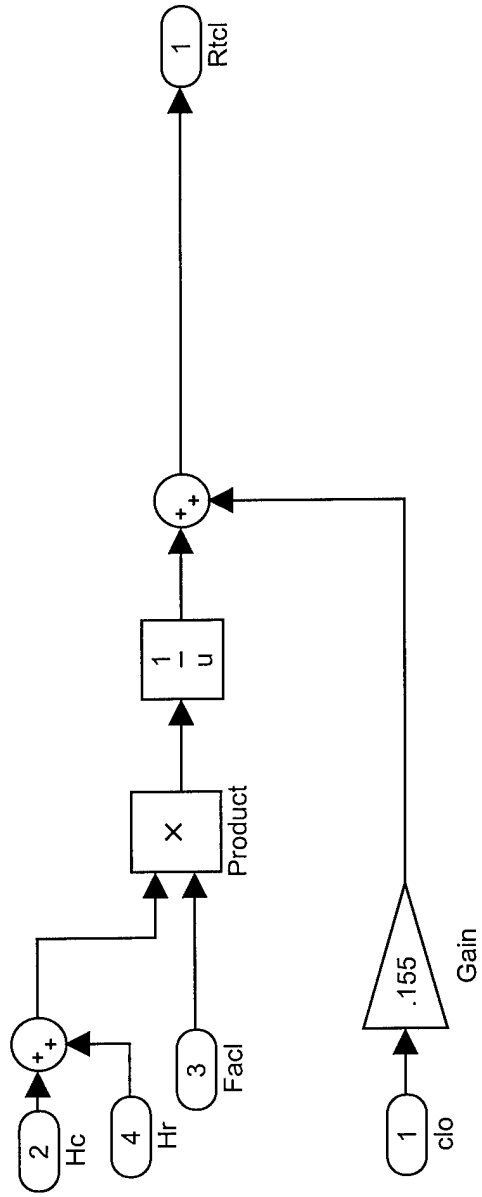

Estimate of linear radiation heat transfer coefficient
 $hr = 4 \cdot .725 \cdot (5.67E-08) \cdot (T_{sk} + MRT)^2 / 273^3$

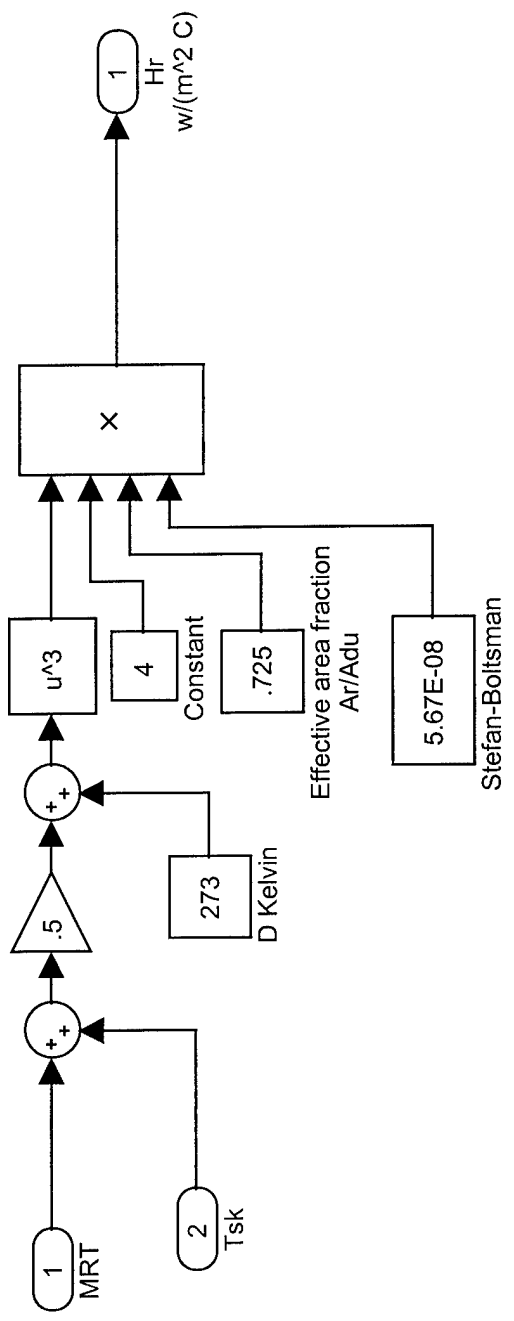

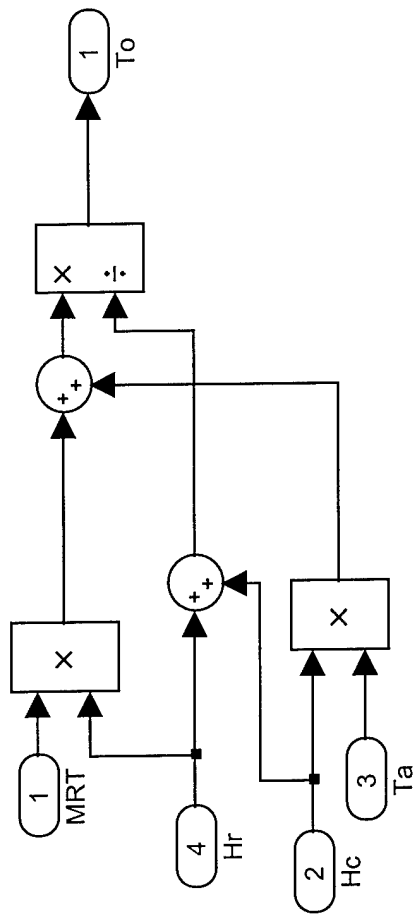

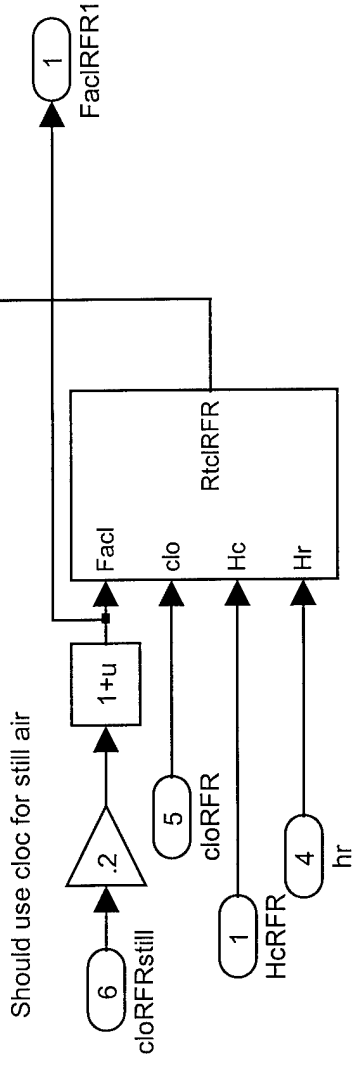
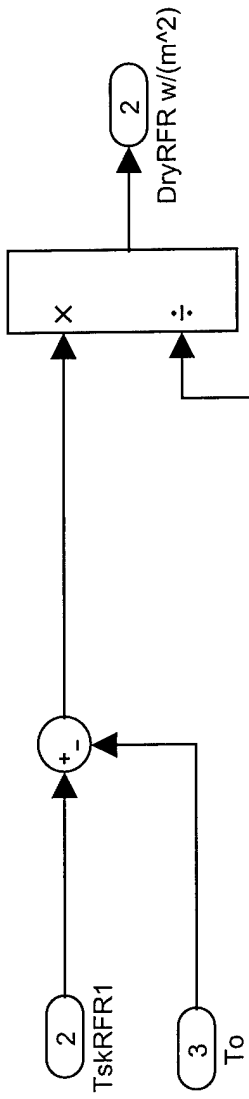

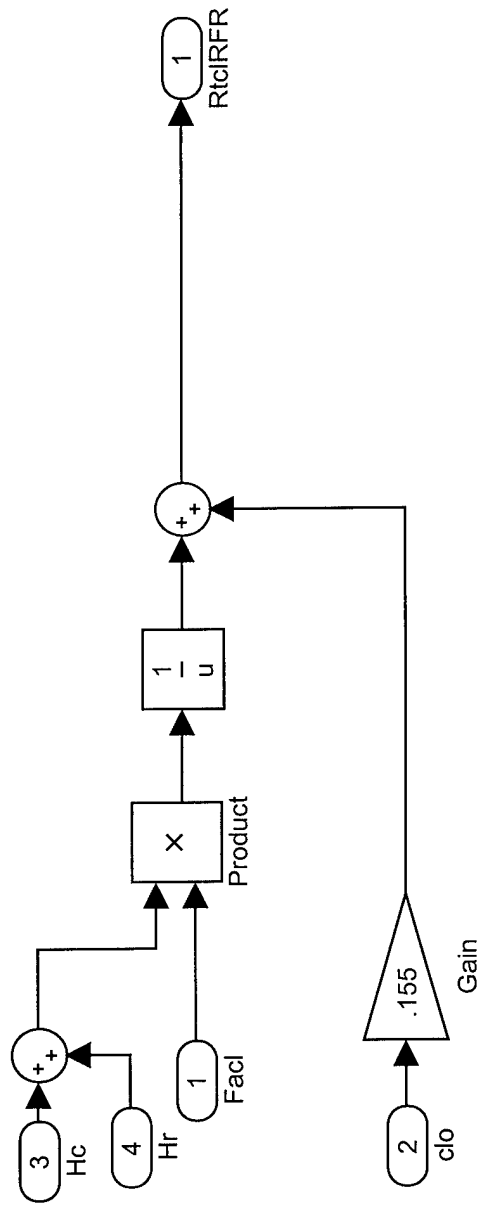

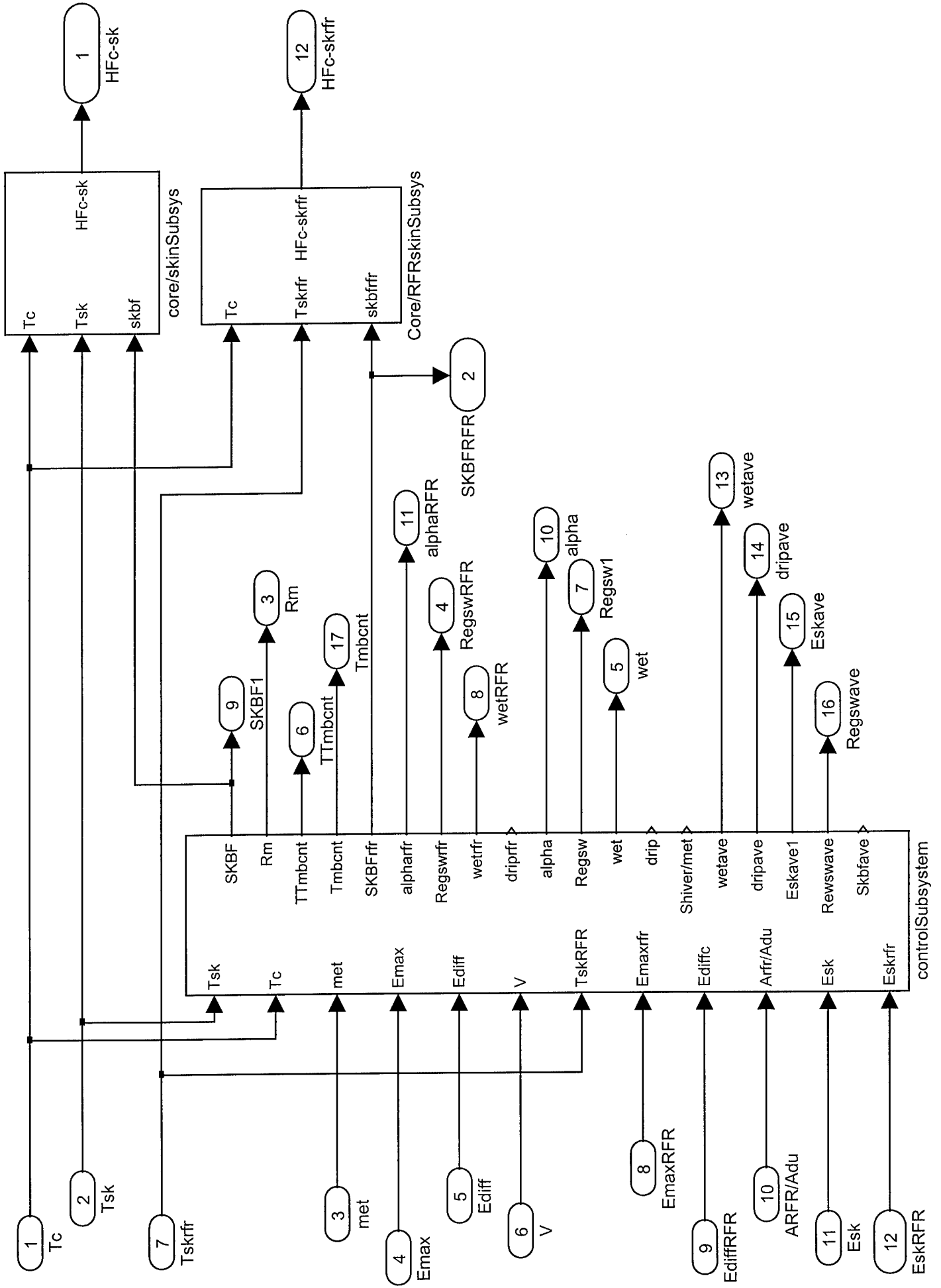

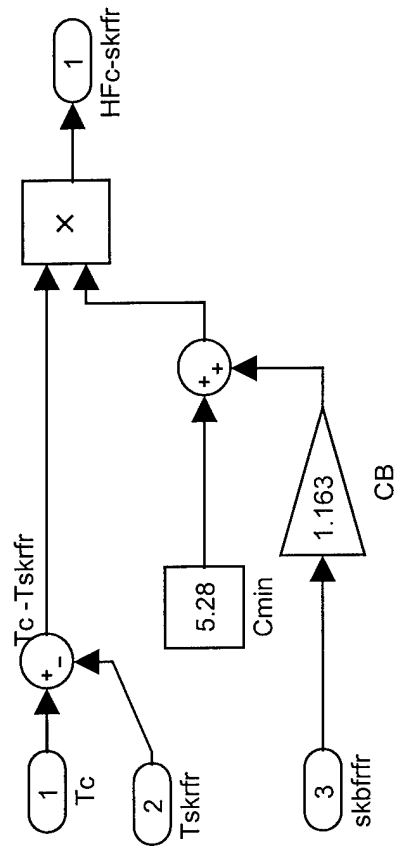

Core to skin heat transfer for area under air cooled clothing

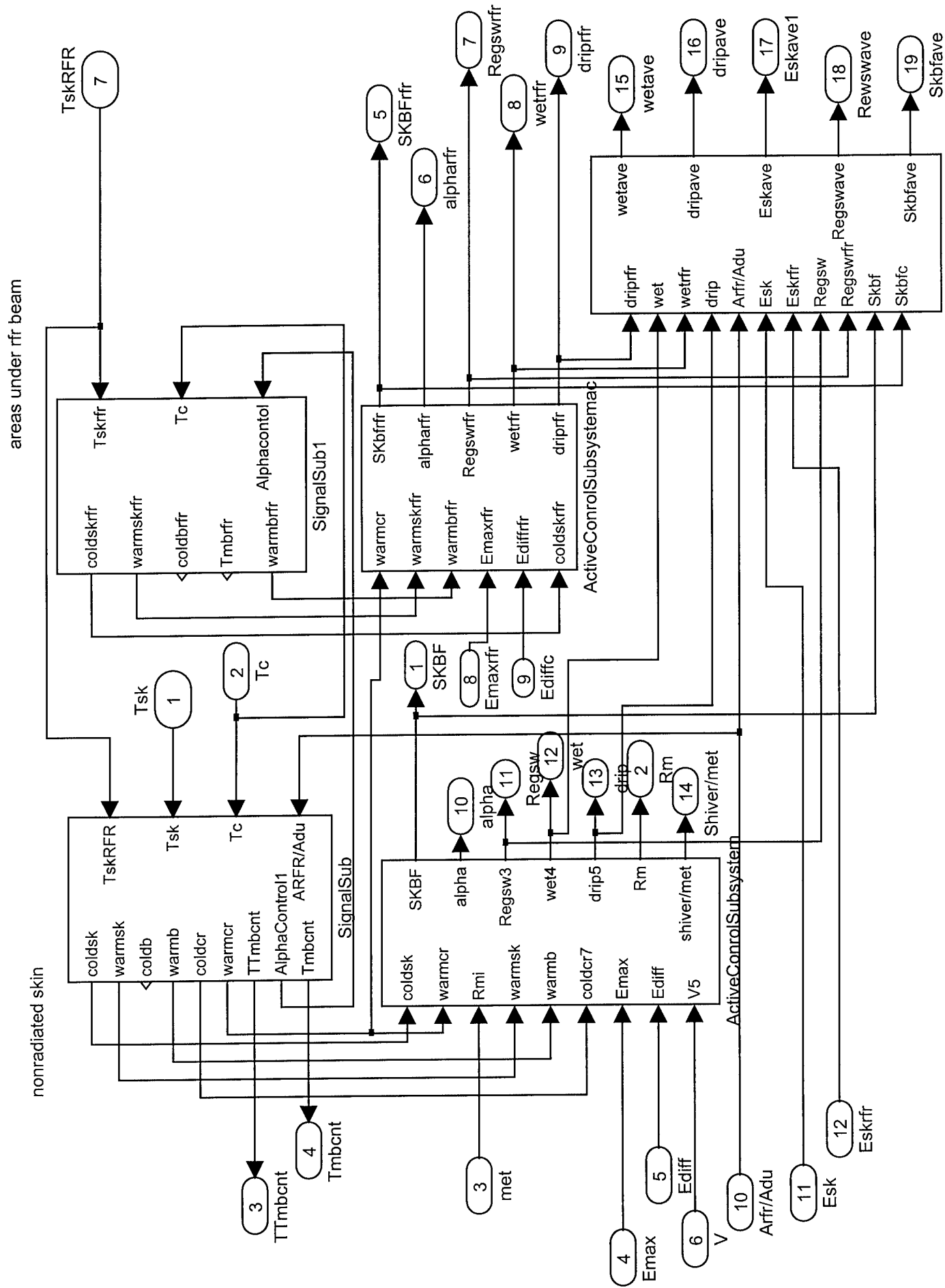

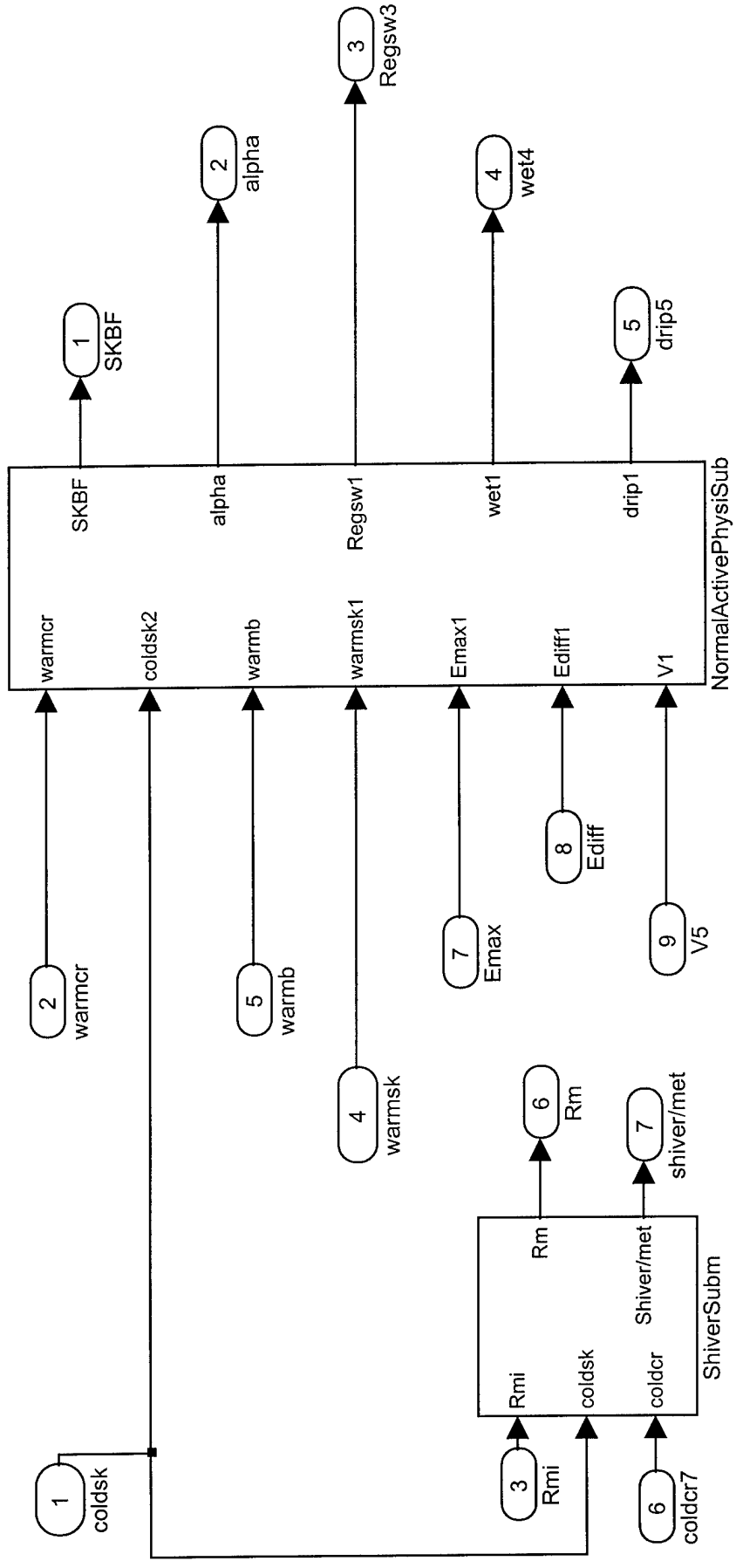

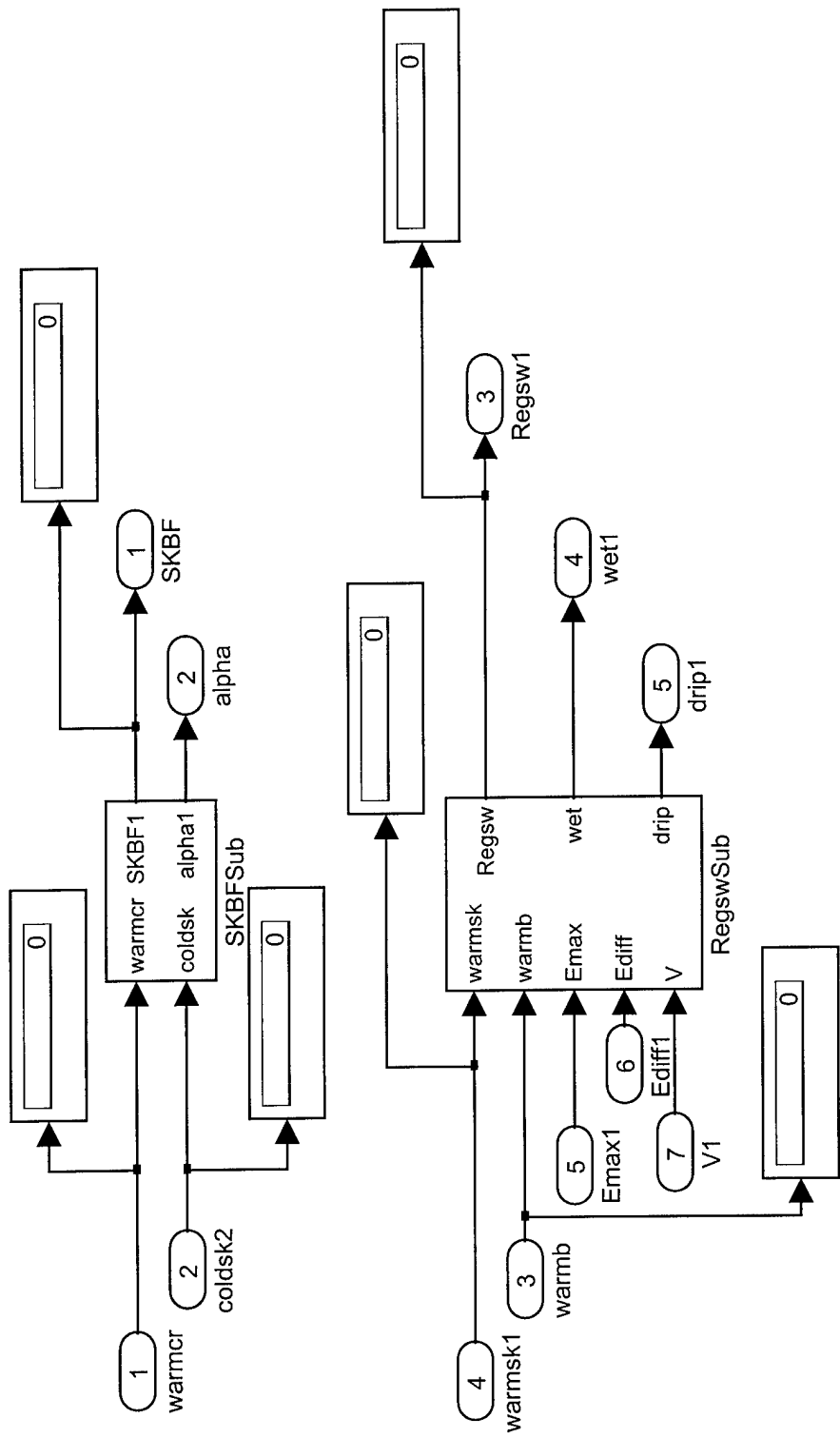

check if Regsw > 667 $g/(m^2 \cdot h)$

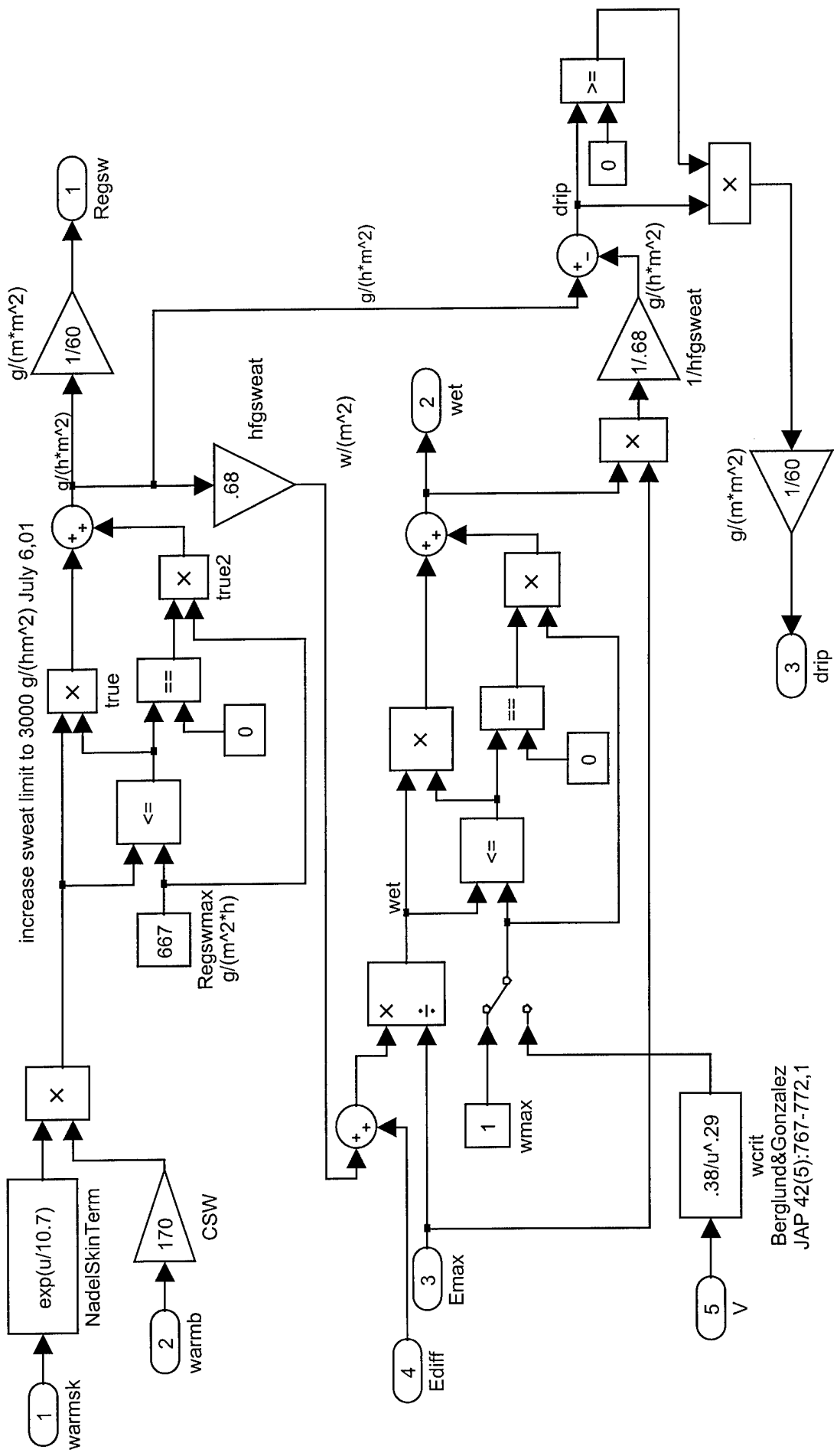

Berglund & Gonzalez
JAP 42(5):767-772, 1

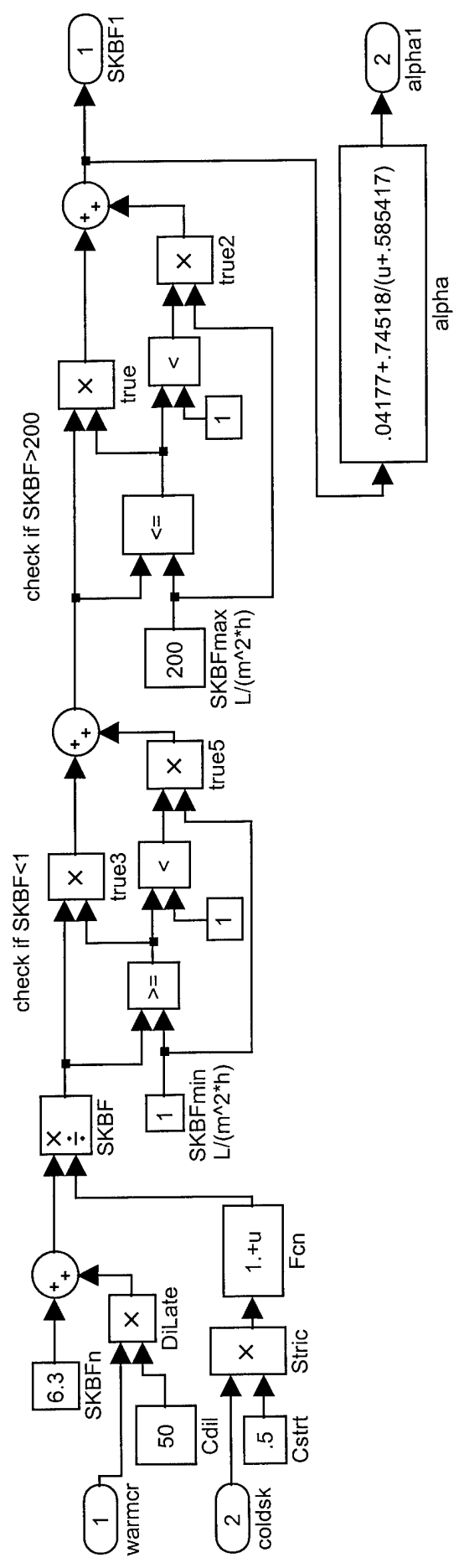

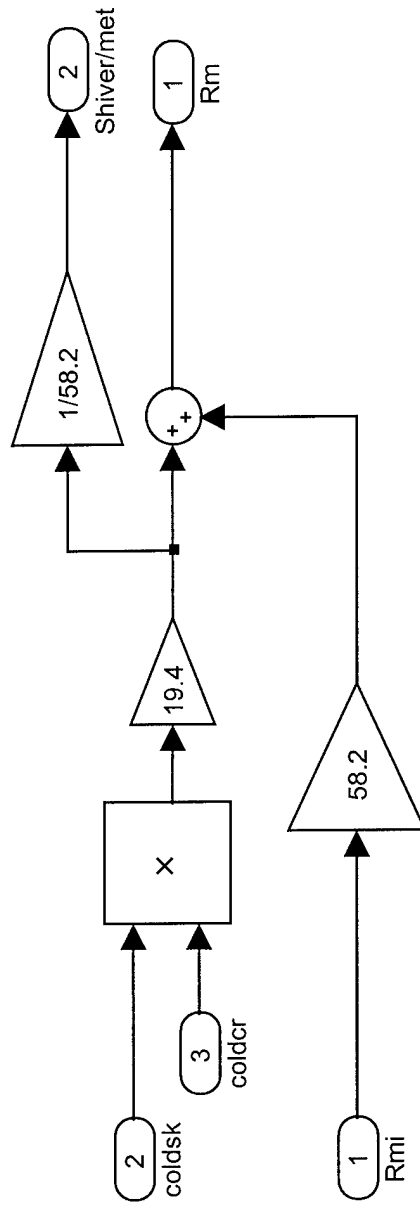

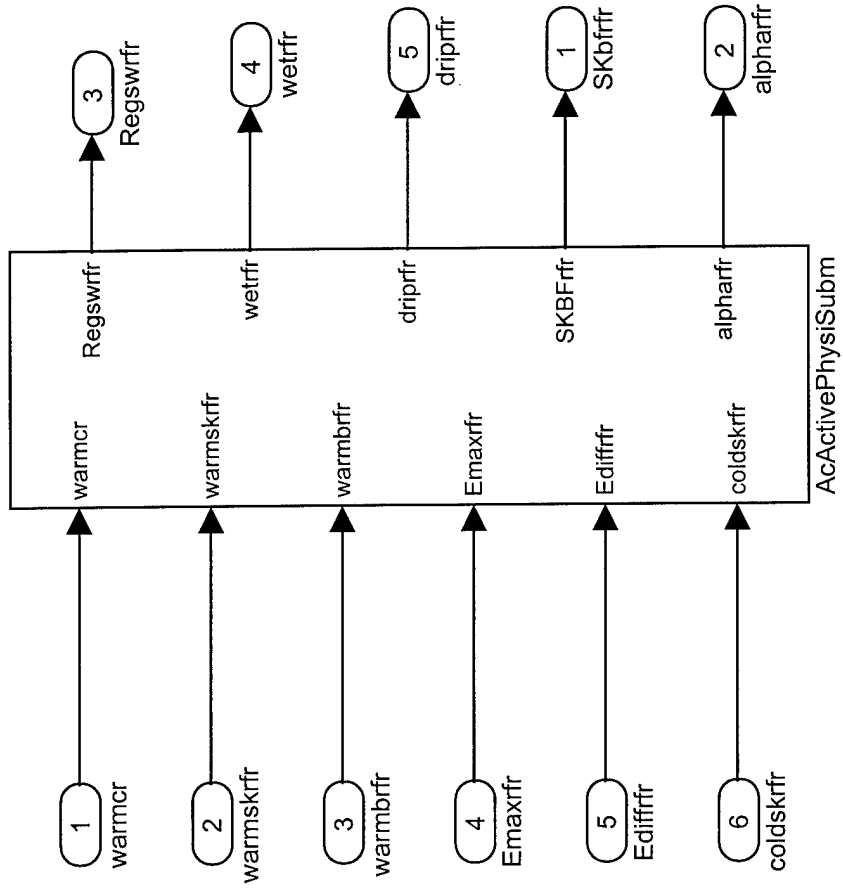

SubSystems for rfr beam

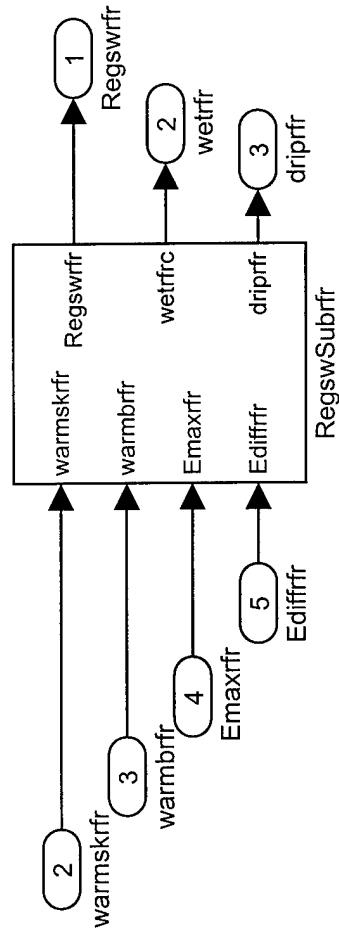
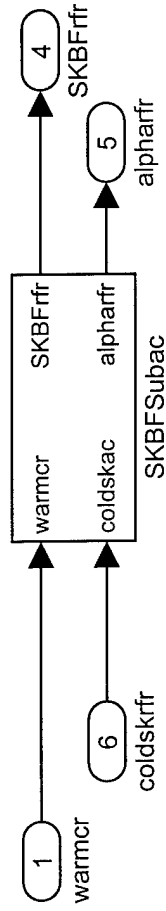

For skin under rfr beam

check if Regsw>667 g/(hm^2)

increase sweat limit to 3000 g/(hm^2)

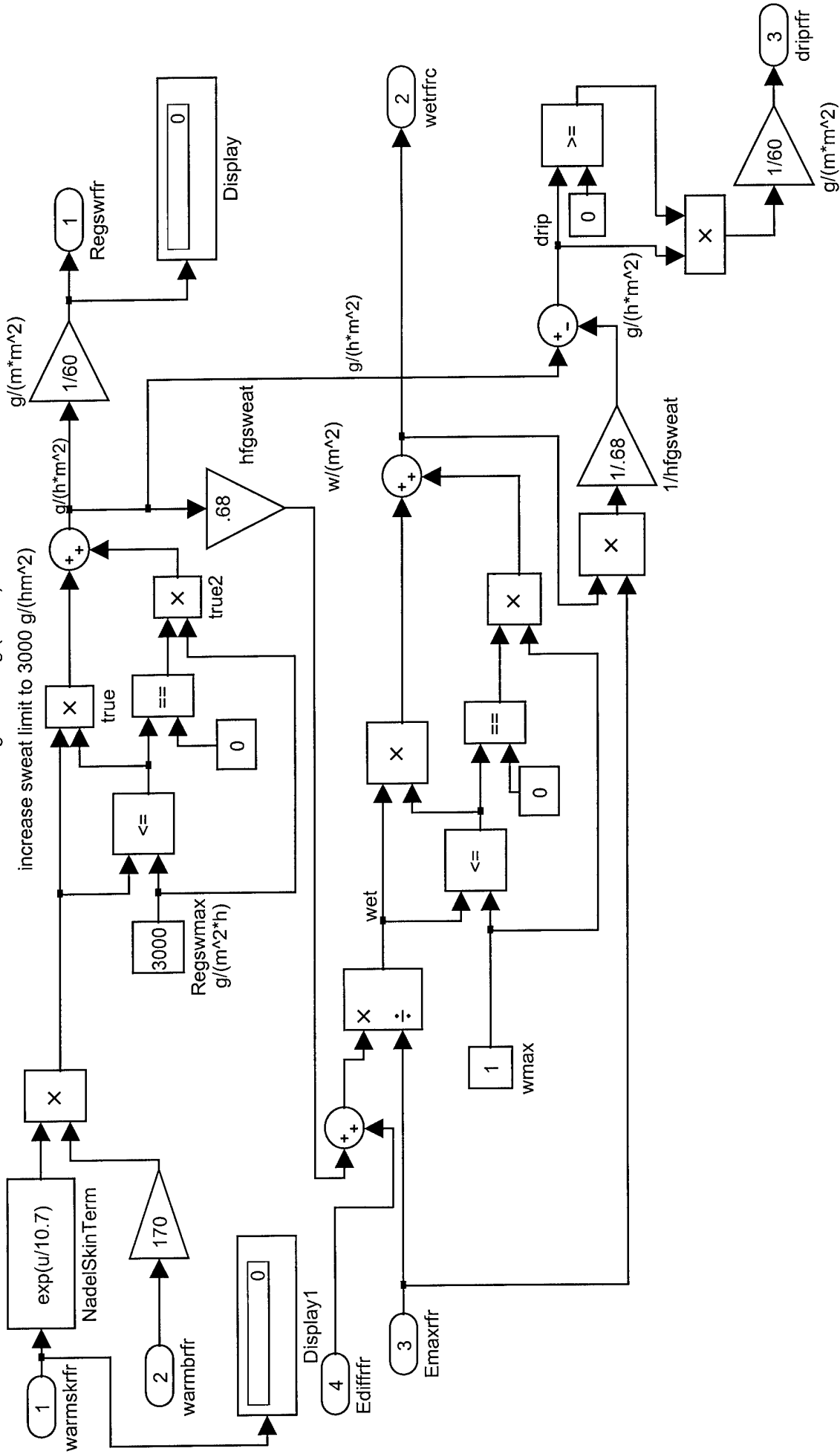

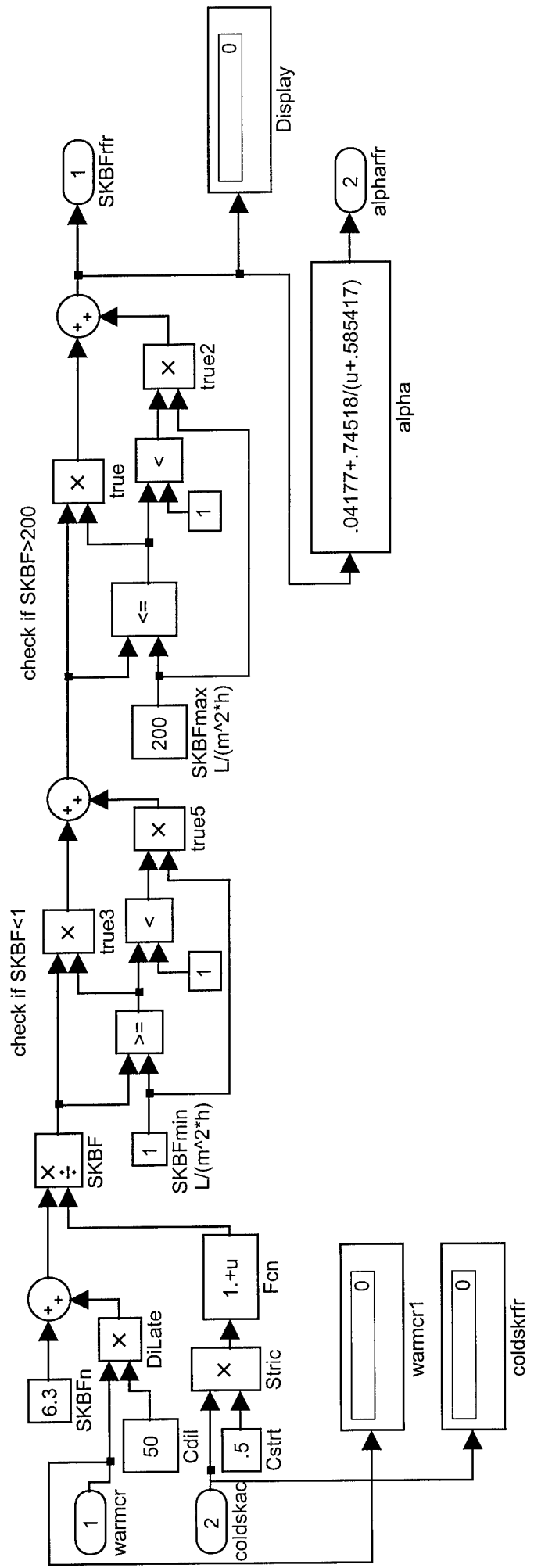

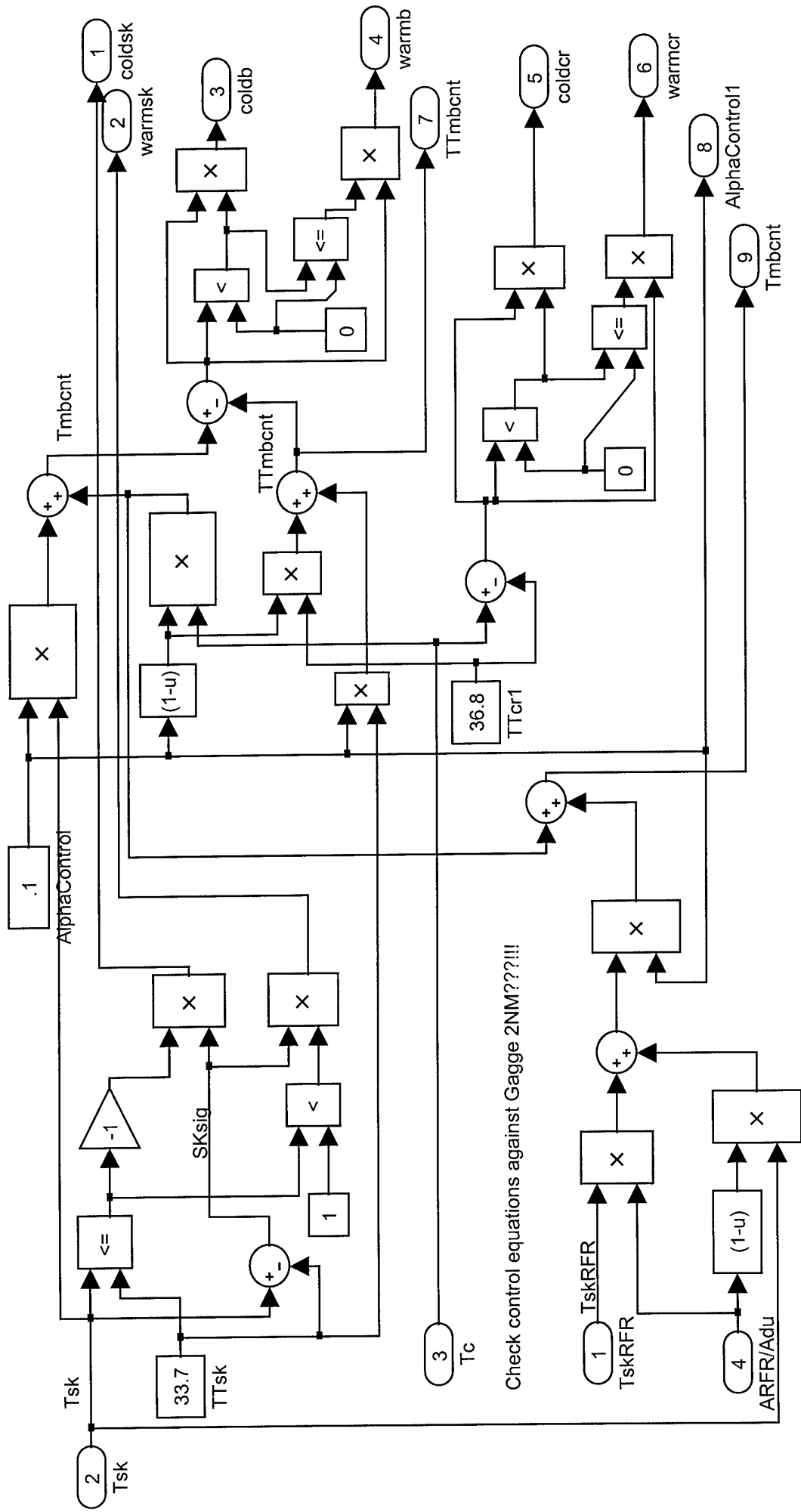

Check control equations against Gagge 2NM???!?

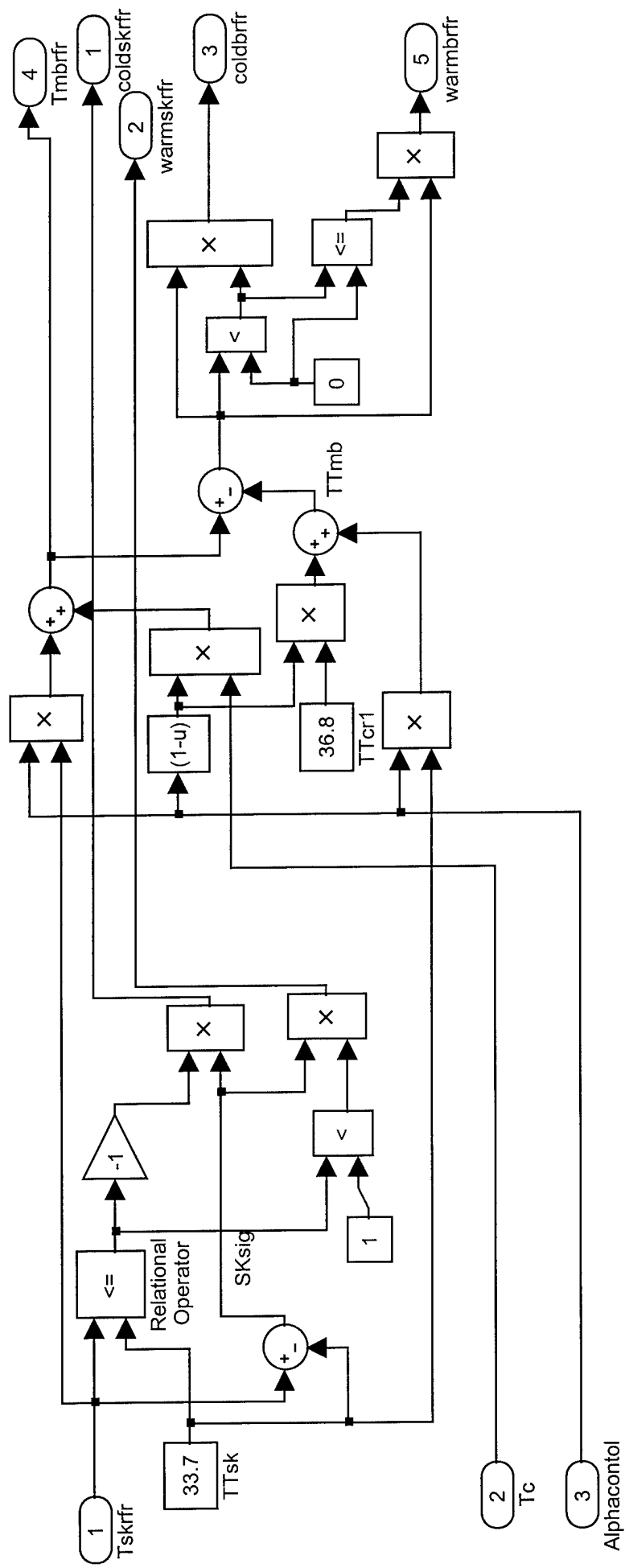

Physiological Control signals for areas under rfr beam

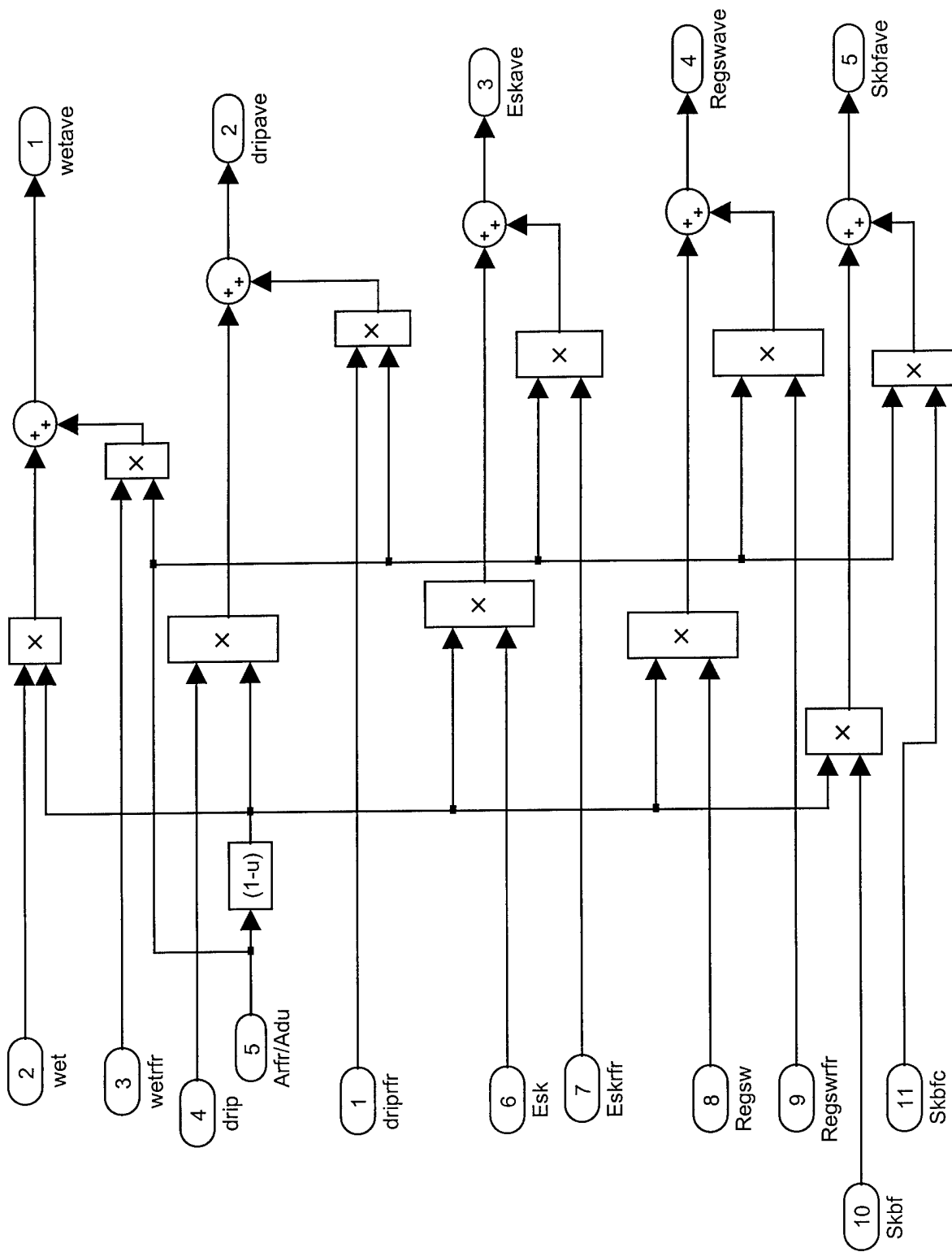

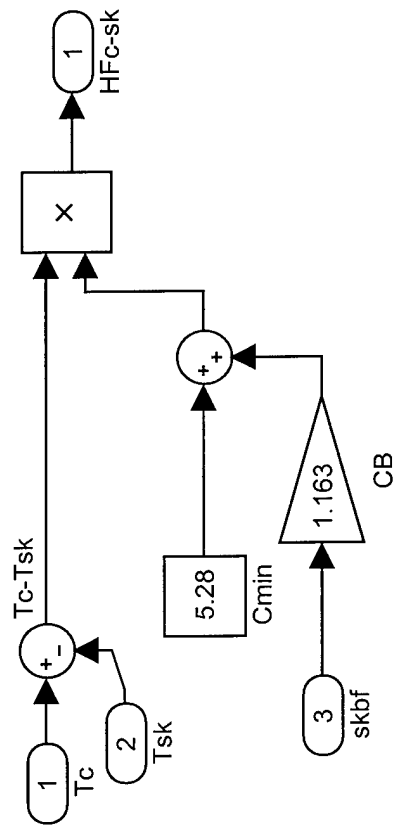

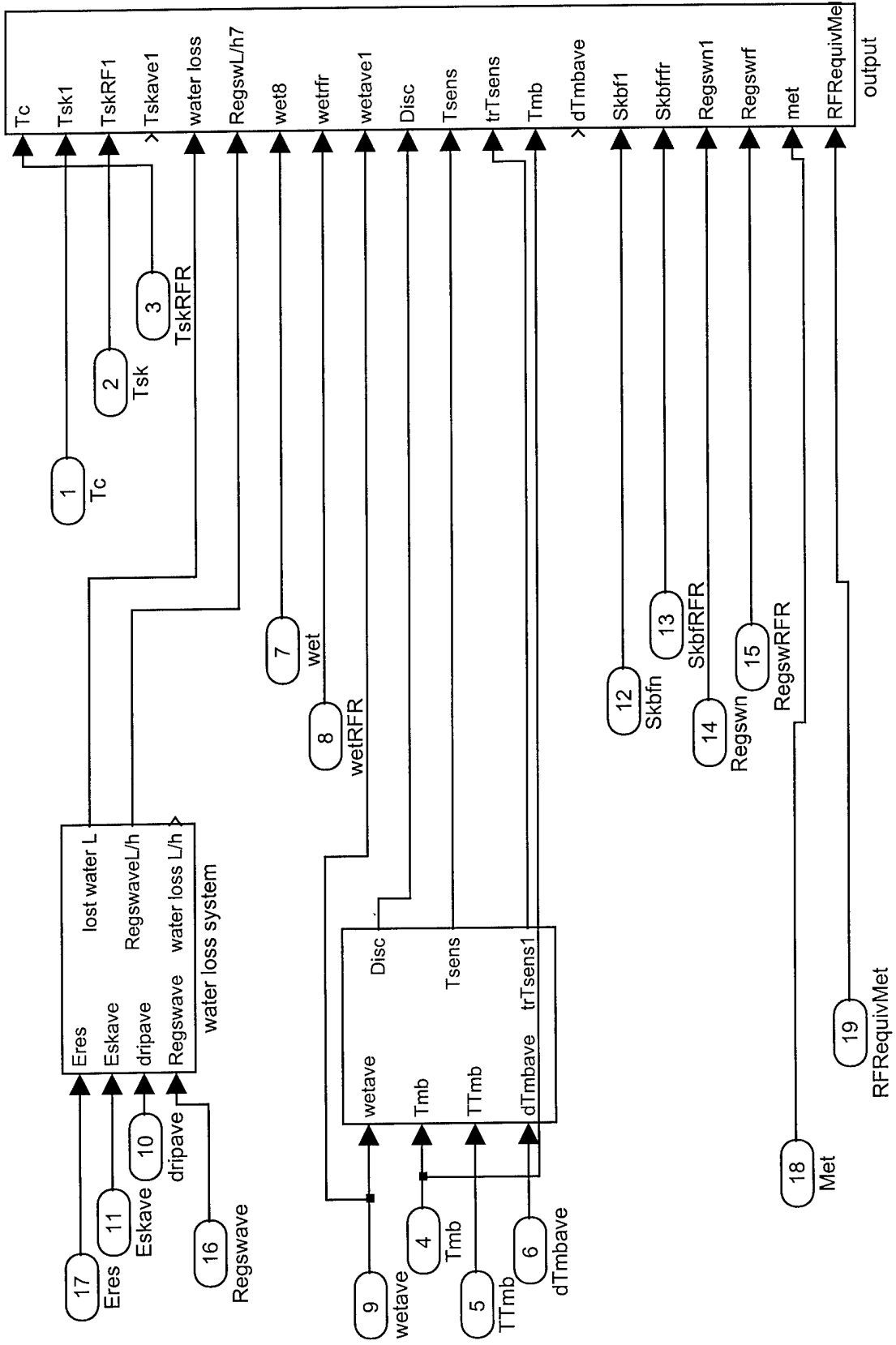

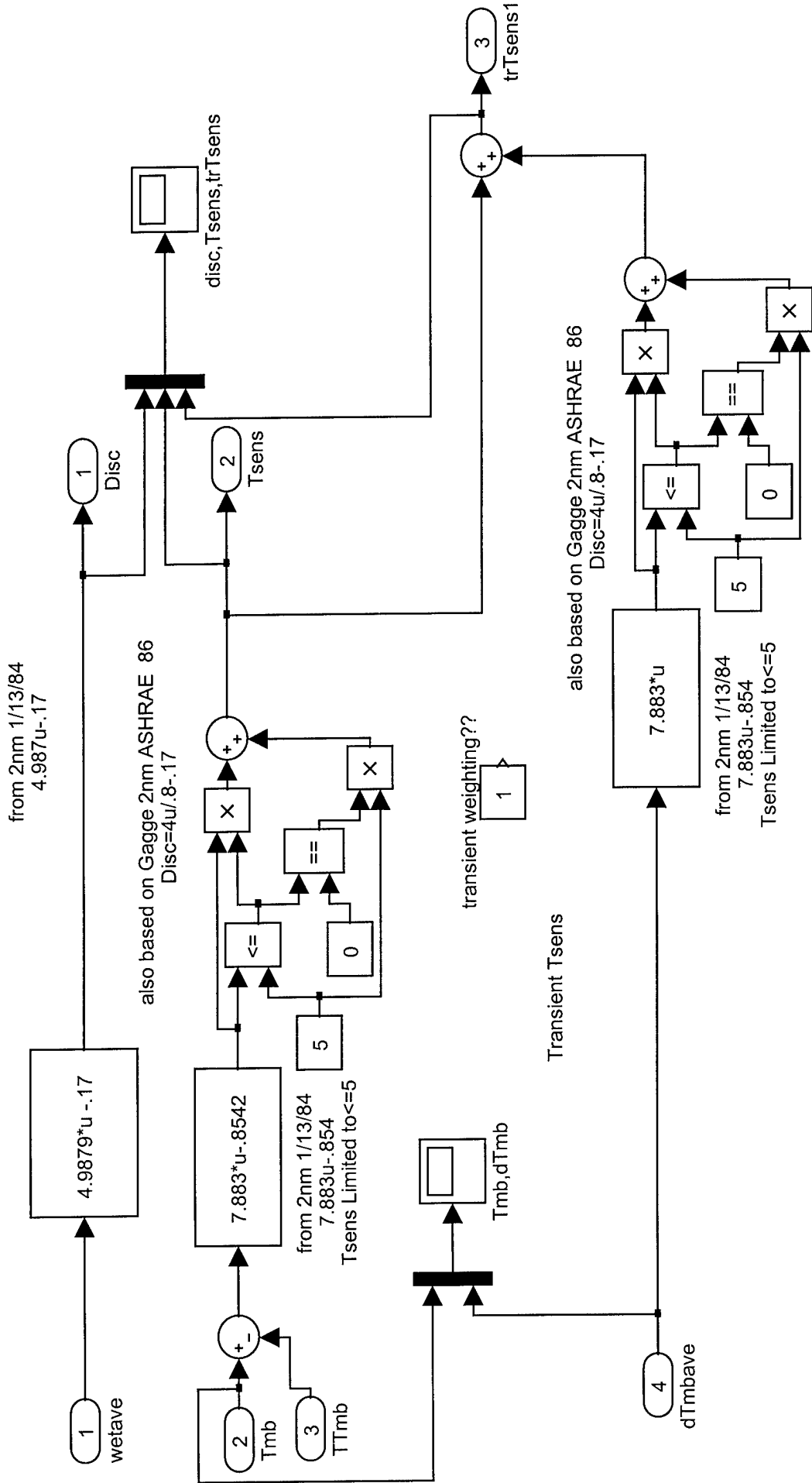

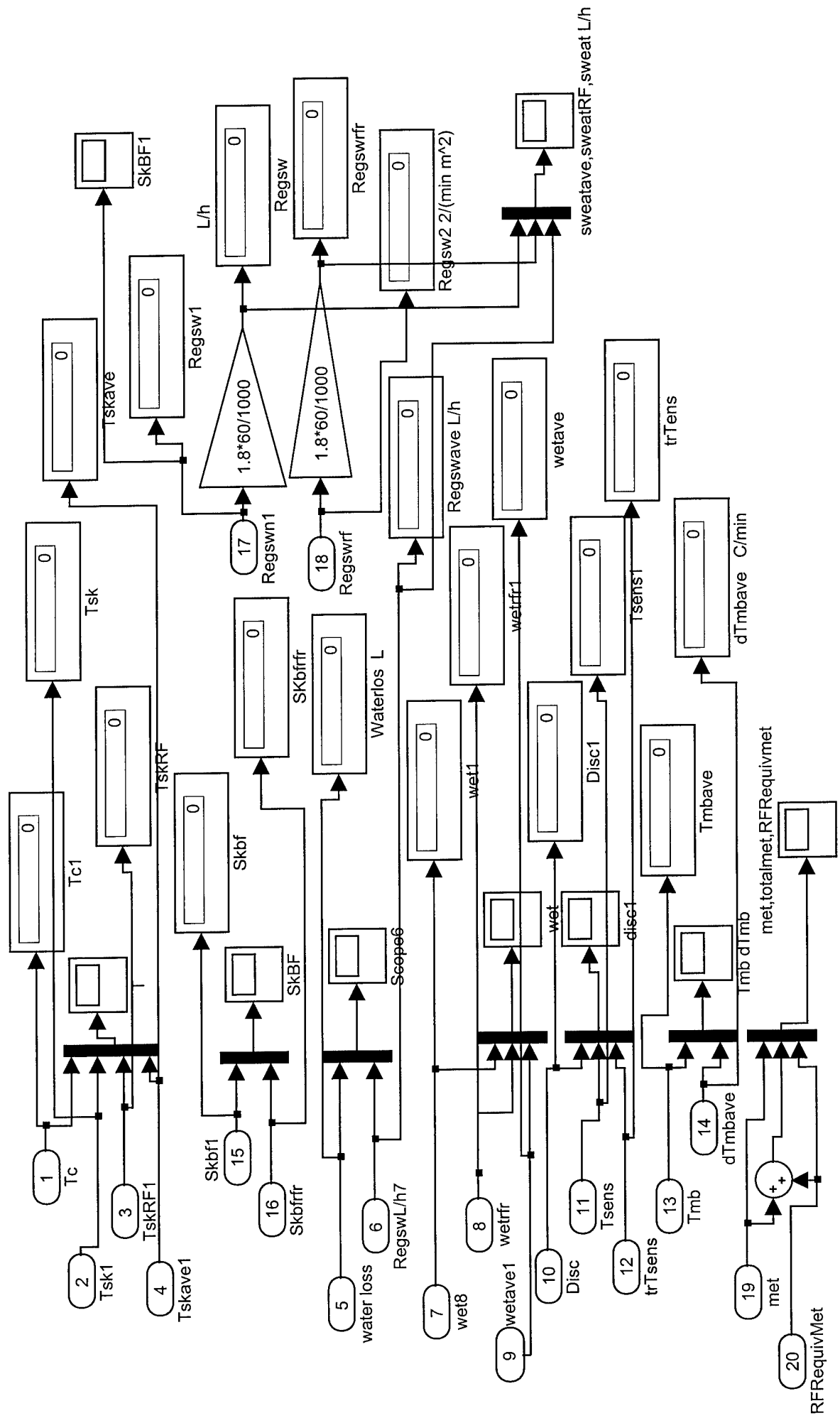

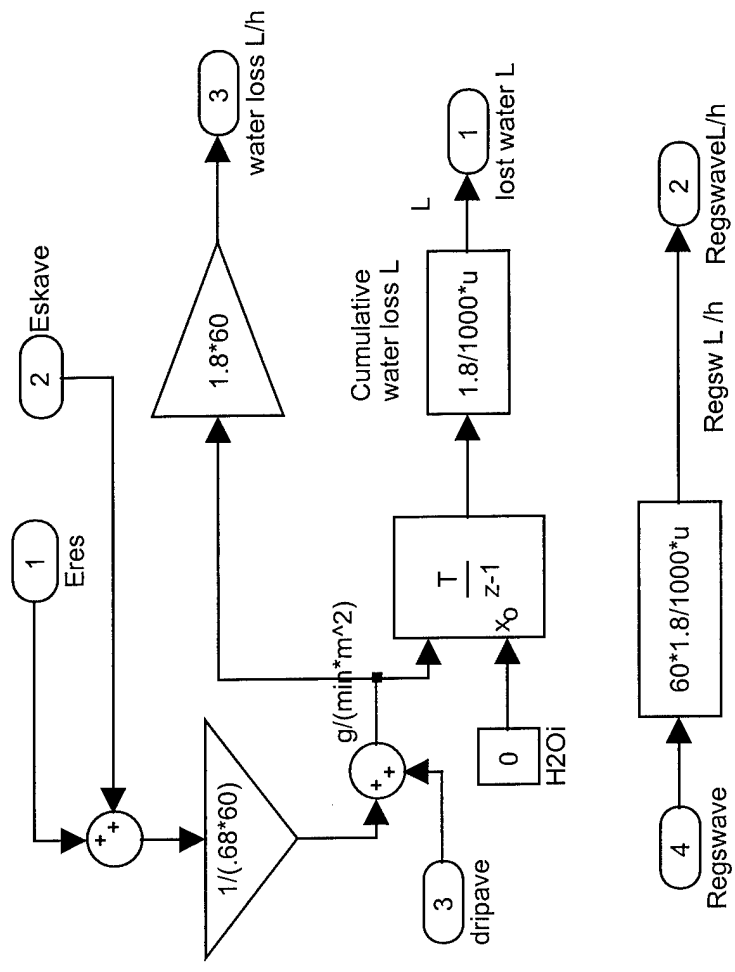

Appendix B

Human response data used in comparison testing

PHYSIOLOGICAL AND PERCEPTUAL RESPONSES OF HUMAN VOLUNTEERS DURING WHOLE-BODY RF EXPOSURE AT 450 MHz

Eleanor R. Adair,¹ Sharon A. Kelleher,² Larry G. Berglund,³ and Gary W. Mack²

¹Armstrong Laboratory, Brooks Air Force Base, TX

²John B. Pierce Laboratory, New Haven, CT

³Tohoku University, Aoba-Ku, Sendai, Japan

INTRODUCTION

The rationale behind all investigations of radio frequency (RF) bioeffects, whether *in vivo* or *in vitro*, ultimately concerns the effects of such exposure on human beings. Voluminous animal bioeffects data have been collected over the last 40-50 years. However, controlled laboratory investigations of human responses to such fields are meager and tend to be limited to sensory endpoints. We have initiated a series of studies to obtain accurate knowledge of human thermoregulatory efficiency in the RF environment; these data are designed to provide generalizable functional relationships that can serve as the basis for human safety guidelines. The functions will also be invaluable to the refinement of computer models designed to predict human thermoregulatory responses in the presence of RF energy and aid the extrapolation of animal data to the human condition. As adjuncts to the physiological data, we have also developed a set of criteria by which R.F.-exposed humans may rate their perceptual impressions of their thermal environment and their physiological responses. The perceptual data are featured in this report.

METHODS

We have developed techniques and protocols to assess responses of heat production and heat loss in human volunteers exposed dorsally to RF energy at 450 MHz. These physiological measures included deep body temperature (esophageal), 6 skin temperatures (upper and lower back, chest, forearm, thigh, and forehead), metabolic heat production from O₂ consumption and CO₂ production, skin blood flow (back), and local sweating rate (back and chest). We also obtained periodic judgments of thermal sensation and thermal comfort, perceived skin wettedness and sweating, thermal preference and thermal acceptability. Seven adult volunteers served as subjects, 4 females and 3 males, aged 21 to 57 years. Each subject was tested nine times using a protocol that involved 45-min whole body exposures to 450 MHz CW R-F energy or sham exposure (no RF present).

During the test, the fully-instrumented subject sat in the far field of a dipole antenna (mounted in a corner reflector) inside an anechoic chamber. The subject's compartment was maintained at one of three ambient temperatures (T_a), 24, 28 or 31 °C (cool, neutral, or warm). The subject was in continuous video and audio contact with the experimenters outside the chamber. Two power densities [peak PD = 18 and 24 mW/cm²; peak specific absorption rate (SAR) = 0.032 (W/kg)/(mW/cm²)] were tested in each of the three T_a, plus T_a controls (no R.F.). The protocol for each test session was the same and comprised three temporal segments: a 30-min equilibration to the T_a, a 45-min RF (or sham) exposure, and a 10-min re-equilibration. At minutes 25, 45, 65, and 80, the subject was asked to rate thermal comfort, thermal sensation, perceived skin wettedness, perceived sweating, T_a preference, and T_a acceptability, using specific category scales.

The subject was asked "How do you feel at this moment?" and rated thermal comfort on a scale from comfortable (0) to intolerable (4), and thermal sensation on a scale from very hot (4) to neutral (0) to very cold (-4). Next the subject was asked to rate skin wettedness on a scale from soaking wet (6) to very dry (0) and perceived sweating on a scale from maximum (5) to none (0). Finally, the subject was asked for thermal preference (cooler = -1, no change = 0, warmer = 1), and whether the environment was thermally acceptable (yes or no).

RESULTS

Mean minute-to-minute values of all measured variables were calculated across the 7 subjects for each test condition. Figure 1 shows representative physiological data for the group of 7 subjects, exposed to RF energy in the thermoneutral environment of 28 °C. Open symbols code the data for a power density of 18 mW/cm², while closed symbols code the data for the higher power density, 24 mW/cm². Control (no RF) data are not included in the figure. The upper panel shows esophageal and selected skin temperatures, while the lower panel shows sweating rate from the chest and the back. The vertical lines indicate the end of the 30-min equilibration period, and the end of the 45-min RF exposure period. Some rise in skin temperatures, particularly on the back occurred during RF exposure, but sweating occurred on back and chest only during exposure to the higher power density. However, during RF exposure at both power densities, no change occurred in the deep body temperature, measured in the esophagus at the level of the heart. During tests in the cool ($T_a = 24\text{ }^{\circ}\text{C}$) environment, no subject exhibited sweating during RF exposure, skin temperature elevations were modest, and no change was measured in esophageal temperature. In the warm ($T_a = 31\text{ }^{\circ}\text{C}$) environment, all subjects were sweating under the high power density, most under the lower power density; some skin temperatures fell during RF exposure due to skin cooling associated with the evaporation of sweat but still no significant rise in esophageal temperature occurred.

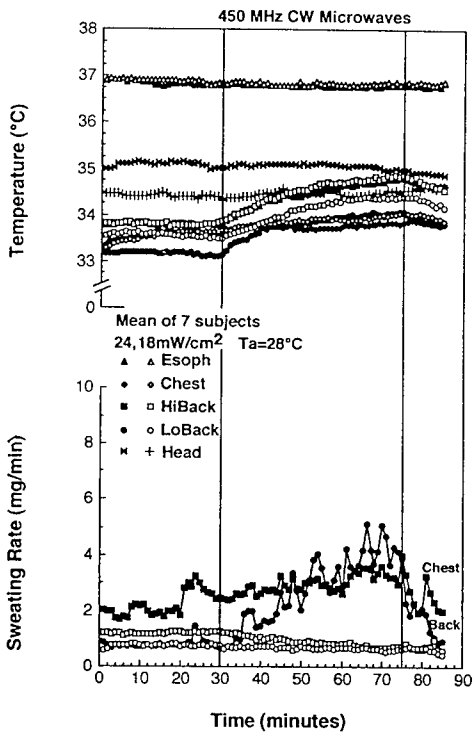

Figure 1. Group mean physiological responses for two power densities in the 28 °C environment. Body temperatures shown in top panel, local sweating rate in the bottom panel.

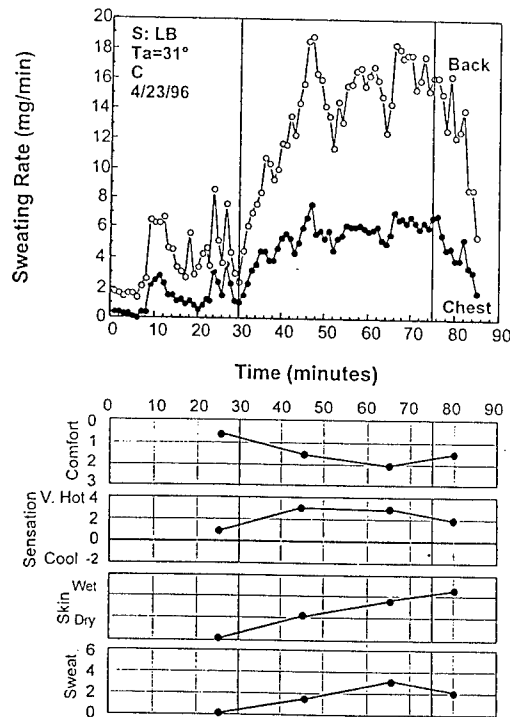

Figure 2. Local sweating rate (back and chest) and perceptual data for one subject exposed to 450 MHz CW RF energy at 24 mW/cm² in the warm environment.

Perceptual data reflected the physiological state of the subjects. The upper panel of Figure 2 shows local sweating rate data for a single subject under the most thermally-stressful conditions: the higher power density in the warm environment. Although some sweating was evident during the initial 30-min equilibration period, sweating rate increased to significantly higher levels on both back and chest during RF exposure. During this time, judgments of thermal comfort deteriorated from near-comfortable to uncomfortable, thermal sensation rose from neutral to hot, perceived skin wettedness rose from dry to wet, and perceived sweating rose from none to 50% of maximum. All responses, both sweating and perceptual judgments trended toward their initial values when the RF was turned off.

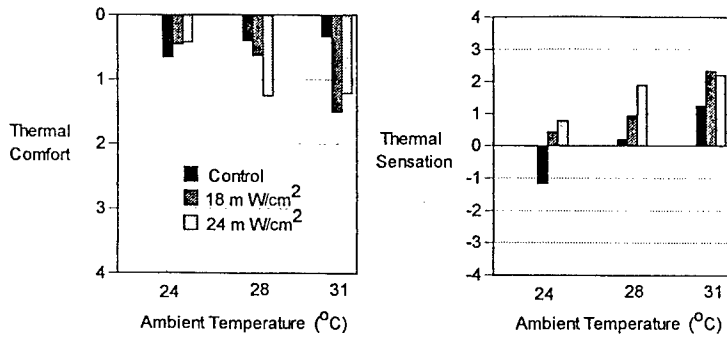

Figure 3. Group mean judgments of thermal comfort (left) and thermal sensation (right), taken five minutes before the end of the 45min RF exposure period, as a function of the prevailing ambient temperature. Black bars indicate control (no RF) tests, dark gray bars indicate tests of the lower power density, and light gray bars indicate tests of the higher power density.

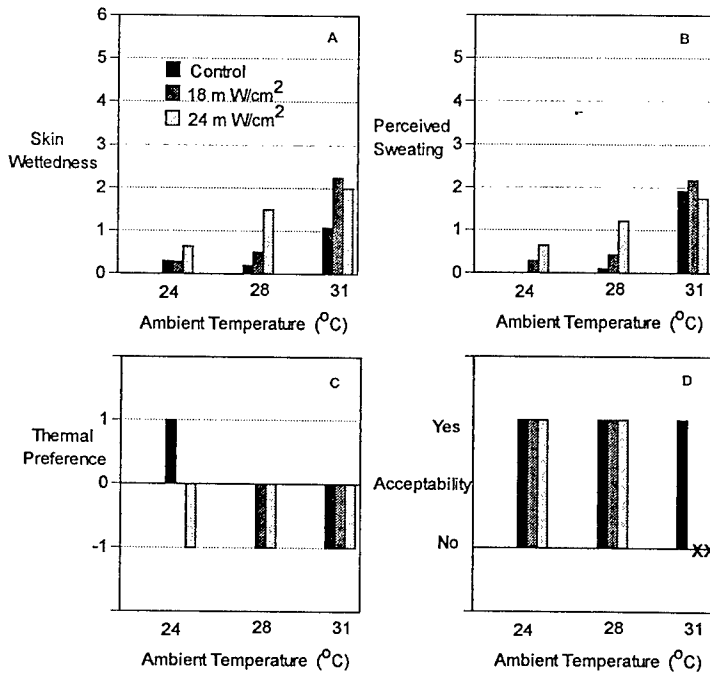

Figure 4. Group mean judgments of skin wettedness (A), perceived sweating (B), thermal preference (C), and thermal acceptability (D), taken five minutes before the end of the RF exposure, as a function of prevailing ambient temperature. Bars coded as in Figure 3.

Figure 3 shows group mean judgments of thermal comfort and thermal sensation just 5 minutes before the RF energy was turned off. Shown are control (sham) exposures in black bars, the low power density in dark gray bars, and the high power density in light gray bars for each test environment, 24, 28 and 31 °C. Only in the cool environment did RF exposure increase thermal comfort, and it did so by changing a cool sensation to a warmer one. In the neutral and warm environments, RF exposure decreased thermal comfort and increased the sensation of warming in proportion to the power density. Further analyses of these data indicated that the change in thermal comfort and thermal sensation, from the end of the equilibration period to the end of the RF exposure period, had little to do with the change in mean skin temperature that occurred, except in the thermoneutral environment. Thus, in the cool environment, skin temperature rose during RF exposure, but thermal comfort deteriorated and thermal sensation changed very little. In the warm environment, skin temperatures rose only slightly during RF exposure due to sweating, but discomfort increased sharply and the subjects reported that they felt much warmer. However, in the neutral environment, both thermal discomfort and the sensation of warming increased in proportion to the rise in mean skin temperature, which was in turn dependent on the power density of the exposure field.

Figure 4 shows mean judgments of skin wettedness, perceived sweating, thermal preference and thermal acceptability taken after 40 minutes of RF (or sham) exposure. Both perceived wettedness and perceived sweating increased in the presence of RF in all environments. The environment was judged thermally acceptable under all conditions EXCEPT during RF exposure at $T_a = 31$ °C. On the other hand, subjects wanted the environment warmer only in the 24 °C with no RF presents wanted no change in the 24 °C environment with 18 mW/cm² and the neutral environment with no RF present. Otherwise the subjects wanted their environment cooler. A comparison between the judgments of perceived sweating and actual sweat rate measurements at the two skin sites showed some discordance between the two. Subjects did not sweat at all in the cool environment and, in the neutral environment ($T_a = 28$ °C), sweating was measured only when the 24 mW/cm² field was present. In some of these cases, subjects judged that they were sweating when they were not. On the other hand, when subjects were actually sweating, such as in the warm environment when the RF field was present, their perceptions were reasonably accurate. Thermal physiologists have traditionally linked thermal discomfort with skin wettedness¹. A comparison between the thermal comfort data in Figure 3 and the skin wettedness data in panel A of Figure 4, in fact, confirm this strong association. In this context it is important to remember that a judgment of "0" on the thermal comfort scale indicates maximal comfort, while judgments of "1", "2", etc. indicate greater and greater discomfort.

SUMMARY AND CONCLUSIONS

The study described here is the first of a planned series in which human volunteers undergo exposure of the whole body to controlled RF fields in highly controlled thermal environments. At the highest peak power density explored in the present study (24 mW/cm²), the calculated whole-body SAR of 0.19 W/kg was well within the ANSI/IEEE C95.1-1992 guideline² for a "controlled environment" at 450 MHz, but was more than double the guideline for an "uncontrolled environment". In our experiments, we found that, even under ambient conditions (including RF exposure) that were often judged to be uncomfortable and thermally stressful, the internal body temperature of the subjects was regulated with precision by the mobilization of appropriate heat loss responses, principally sweating. Further, the subjects were generally aware of their altered thermal environment and their own physiological state. These perceptions could lead to effective evasive action, if necessary, to maintain thermal homeostasis.

REFERENCES

1. ASHRAE Fundamentals (1993). Chapter 8. Physiological principles and thermal comfort. Atlanta, GA: American Society of Heating, Refrigerating, and Air-Conditioning Engineers, pp. 8.1 - 8.29
2. ANSI/IEEE C95.1 (1992). IEEE Standard for Safety Levels with Respect to Human Exposure to Radio Frequency Electromagnetic Fields, 3 kHz to 300 GHz. New York: Institute of Electrical and Electronics Engineers.

100 MHz CW Microwaves

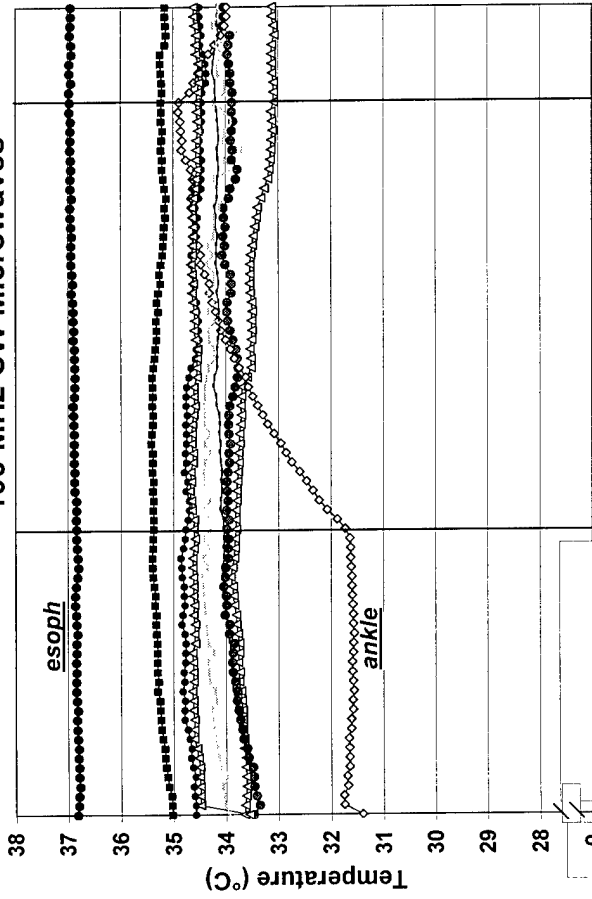

Group Mean N=7
31°C 8mW/cm²

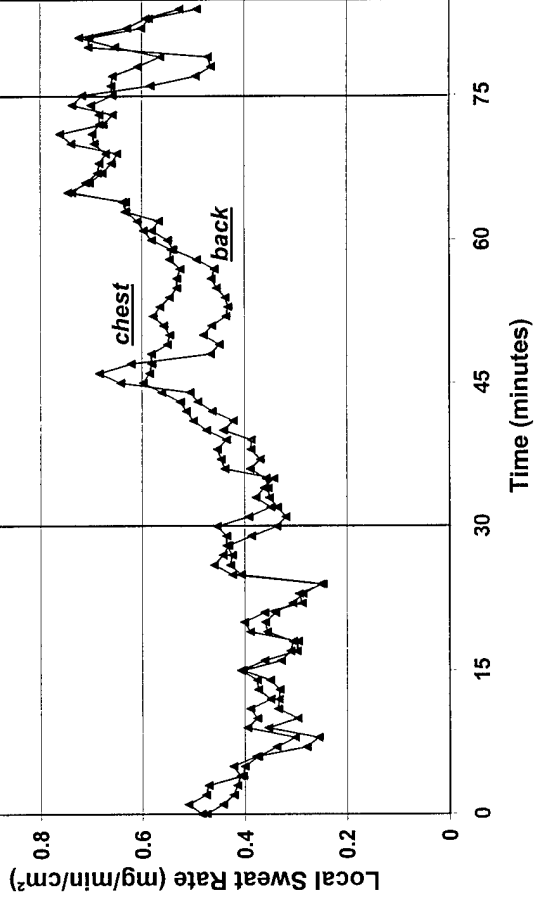

100 MHz CW Microwaves

