

ARMY RESEARCH LABORATORY



Close-Quarters Combat Shot Shell

by Robert P. Kaste

ARL-TR-2692

March 2002

Approved for public release; distribution is unlimited.

20020514 125

The findings in this report are not to be construed as an official Department of the Army position unless so designated by other authorized documents.

Citation of manufacturer's or trade names does not constitute an official endorsement or approval of the use thereof.

Destroy this report when it is no longer needed. Do not return it to the originator.

Army Research Laboratory

Aberdeen Proving Ground, MD 21005-5069

ARL-TR-2692

March 2002

Close-Quarters Combat Shot Shell

Robert P. Kaste

Weapons and Materials Research Directorate, ARL

Approved for public release; distribution is unlimited.

Abstract

The theory and design for a shot shell that produces a wider-than-standard shot spread are described. The technique implemented utilizes the pressure generated by the propulsion charge to apply radial force on the shot column within the shotgun barrel, causing an increase in shot divergence upon exit from the weapon. The increase in shot pattern size is intended for application of the shotgun as an area weapon for close-quarter applications, which might occur in military operations on urban terrain (MOUT) or civilian policing operations.

Acknowledgments

The author wishes to thank Andrew Brant of the U.S. Army Research Laboratory (ARL) for his time and effort producing the interior ballistic calculations used in this study. Dr. Lawrence J. Puckett is also to be commended, largely through his doggedness, for providing the funding to perform this project. Grateful appreciation is extended to Dennis Henry, who provided tremendous help performing the experiments and collecting the data. Thanks is also extended to the ARL model shop for their excellent work in fabrication.

INTENTIONALLY LEFT BLANK.

Contents

Acknowledgments	iii
List of Figures	vii
List of Tables	vii
1. Background	1
2. Shot Cup Designs	2
3. Method of Testing	5
4. Results	6
5. Discussion	8
6. Conclusions	9
7. Recommendations	9
Appendix A. Effectiveness of Shot Spread	11
Appendix B. Shot Spread via Pressurization	13
Appendix C. Shotgun Terminology	15
Distribution List	17
Report Documentation Page	25

INTENTIONALLY LEFT BLANK.

List of Figures

Figure 1. Area coverage of a shotgun.....	2
Figure 2. Patent concept.	3
Figure 3. Shot cup designs.	5
Figure 4. Ball check valve design.	6
Figure 5. H. P. White insert configurations.	7
Figure 6. Damage to shot cups.	8

List of Tables

Table 1. ARL shot spread results.....	8
---------------------------------------	---

INTENTIONALLY LEFT BLANK.

1. Background

While a shotgun is perceived as an area coverage weapon, its effectiveness as an area weapon is extremely limited in short-range, close-quarters, antipersonnel engagements such as those encountered inside a room or building during military operations on urban terrain (MOUT). A 12-gauge riot shotgun produces a shot divergence angle of only 3° – 4° , clearly not effective for close-quarters area coverage (Figure 1). In order to cover an area 54×54 in (1.372×1.372 m) at a range of 15 ft (4.572 m), an angle of divergence of about 17° is required. This report discusses an effort to increase the size of the shot pattern using the concept described in U.S. Patent Numbers (Nos.) 5,191,168¹ and 5,192,830² (Figures 2[a] and 2[b]). The increase would be achieved by the development of a novel internally pressurized pusher "sabot," or cup, to replace the current cup, coupled with alternative shot stacking patterns and placement within the shell casing. A cooperative research and development agreement (CRDA) between the U.S. Army Research Laboratory (ARL) Weapons Technology Division (WTD) and H. P. White Laboratory, Inc., was established to pursue the concept, which is believed to have military, law enforcement, and sporting use. In this CRDA, the necessary analytical and experimental work required to explore a practical solution was shared by both the participants, with WTD performing the bulk of the analytic work.

While an increase in shot pattern size is desirable for the close-quarters application, it is also important to consider the effectiveness on the area covered. If the shot pattern is spread too thin, the impact energy delivered to a soldier-sized target will be so low as to render it ineffective. Conversely, if each pellet has enough energy to be in itself effective, the target size that could be covered by a single round would be limited by the total number of pellets fired. The number of pellets would be constrained by the interior ballistic design (i.e., the pressure rating for a shotgun barrel that is affected by the total launch mass for a given launch velocity). Appendix A presents the muzzle energies of some commonly used rounds and describes the process used to determine the desired total target area. A 12-gauge shotgun shell supplies a considerable amount of energy (about 1646 ft·lb or 2232 N·m). A single shot shell, in principle, could inflict damage to multiple people based on its available energy alone. However, it is impractical to engage too large a target. This, too, is described in Appendix A.

¹Puckett, L. "Sabot for High Dispersion Shot Shell." U.S. Patent No. 5,191,168, 2 March 1993.

²Puckett, L. "Sabot for High Dispersion Shot Shell." U.S. Patent No. 5,192,830, 9 March 1993.

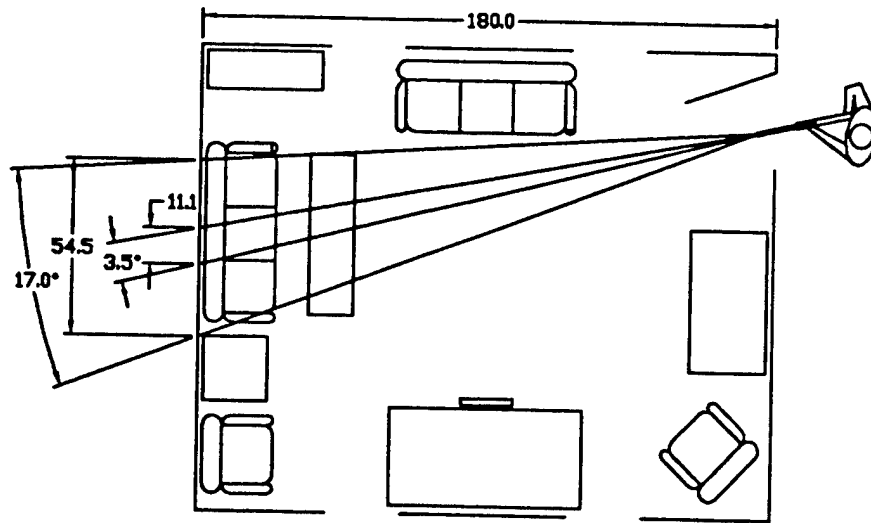

Figure 1. Area coverage of a shotgun.

Preliminary calculations for determining the pressure loading required to achieve the desired shot pattern are presented in Appendix B. Interior ballistic calculations were made to determine what pressures would be available at the muzzle for various length shotgun barrels. It was obvious that a shotgun with a barrel of any significant length would not have the necessary muzzle pressure to substantially increase the size of the shot pattern. However, as sufficient pressure is available earlier in the ballistic cycle from the propulsion gases, and as the volume within the shot cup is sufficiently small as to cause only minimal change to the interior ballistic combustion conditions, departure from the original patents was taken to include the concept of pressurizing and the maintaining of pressure within the shot cup (this resulted in U.S. Patent No. 5,644,100).¹

2. Shot Cup Designs

ARL produced and tested several shot cups with internal cavities for the propulsion gas to pressurize, creating radial loading on the shot as it traveled down the shotgun barrel. The designs tested are depicted in Figure 3. Unaltered,

¹Puckett, L., and R. Kaste. "Sabot for High-Dispersion Shot Shell." U.S. Patent No. 5,644,100, 1 July 1997.



US005191168A

United States Patent [19]
Puckett

[11] Patent Number: 5,191,168
[45] Date of Patent: Mar. 2, 1993

- [54] SABOT FOR HIGH DISPERSION SHOT SHELL
- [75] Inventor: Lawrence J. Puckett, Churchville, Md.
- [73] Assignee: The United States of America as represented by the Secretary of the Army, Washington, D.C.
- [21] Appl. No.: 828,321
- [22] Filed: Jan. 29, 1992
- [51] Int. Cl.⁵ F42B 7/02
- [52] U.S. Cl. 102/457; 102/520; 102/532
- [58] Field of Search 102/443, 448-461, 102/439, 489, 520-523, 532
- [56] **References Cited**

U.S. PATENT DOCUMENTS

579,429	8/1897	Elliott .	
820,459	4/1906	White .	
875,762	12/1908	Winans et al. .	
1,941,336	9/1933	Barbieri .	
3,261,282	7/1966	Hendricks .	102/453
4,006,688	1/1977	Craft et al. .	
4,167,904	9/1979	Ferri .	102/457
4,800,816	1/1989	Meyer .	102/523

4,882,996 3/1989 Bock et al. .

FOREIGN PATENT DOCUMENTS

92430 11/1968 France 102/532

Primary Examiner—Harold J. Tudor
Attorney, Agent, or Firm—Saul Elbaum; Jason M. Shapiro

[57] **ABSTRACT**

A sabot for a shotgun shell provided with a recess in its base upon which propellant gases may act to radially expand and flatten the sabot thereby enhancing the dispersion of shot. In alternate embodiments the recess may be conoidal, parabolic, pyramidal, or an involute surface resembling a cone. The recess may also be comprised of multiple overlapping layers. Each recess provides a unique shot pattern for short-range antipersonnel engagements. In other embodiments, the foregoing recesses are provided with grooves to facilitate petalling of the recess and flattening of the sabot during and after launch. In another embodiment, the recess is filled with propellant and capped with a consumable plug to delay ignition of the propellant charge, further enhancing shot dispersion.

13 Claims, 5 Drawing Sheets

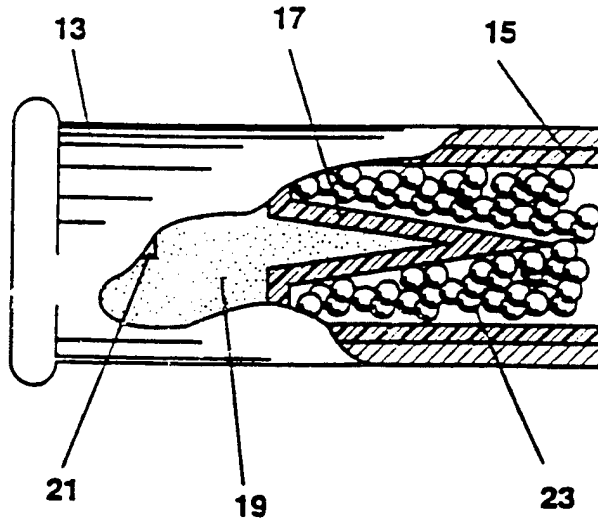

11

(a)

Figure 2. Patent concept.



US005192830A

United States Patent [19]
Puckett

(11) Patent Number: 5,192,830
(45) Date of Patent: Mar. 9, 1993

[54] SABOT FOR HIGH DISPERSION SHOT SHELL

4,167,904 9/1979 Fern 102/451
4,800,816 1/1989 Meyer 102/523
4,882,996 11/1989 Bock et al. .

[75] Inventor: Lawrence J. Puckett, Churchville, Md.

FOREIGN PATENT DOCUMENTS

[73] Assignee: The United States of America as represented by the Secretary of The Army, Washington, D.C.

1262557 4/1961 France 102/449
92430 11/1968 France 102/532

[21] Appl. No.: 931,469

Primary Examiner—Harold J. Tudor
Attorney, Agent, or Firm—Saul Elbaum; Jason M. Shapiro

[22] Filed: Aug. 21, 1992

[57] ABSTRACT

Related U.S. Application Data

[62] Division of Ser. No. 828,321, Jan. 29, 1992.

[51] Int. Cl.: F42B 7/02; F42B 14/06

[52] U.S. Cl.: 102/457; 102/449; 102/522; 102/532

[58] Field of Search 102/439, 443, 448-457, 102/460-463, 489, 506, 520-523, 532

A sabot for a shotgun shell provided with a recess in its base upon which propellant gases may act to radially expand and flatten the sabot thereby enhancing the dispersion of shot. In alternate embodiments the recess may be conoidal, parabolic, pyramidal, or an involute surface resembling a cone. The recess may also be comprised of multiple overlapping layers. Each recess provides a unique shot pattern for short-range antipersonnel engagements. In other embodiments, the foregoing recesses are provided with grooves to facilitate petalling of the recess and flattening of the sabot during and after launch. In another embodiment, the recess is filled with propellant and capped with a consumable plug to delay ignition of the propellant charge, further enhancing shot dispersion.

[56] References Cited

U.S. PATENT DOCUMENTS

579,429 3/1897 Elliott .
820,459 7/1906 White .
875,762 3/1908 Winans et al. .
1,941,336 6/1933 Barbien .
3,261,282 7/1966 Hendricks 102/453
4,006,688 2/1977 Craft et al. .

4 Claims, 4 Drawing Sheets

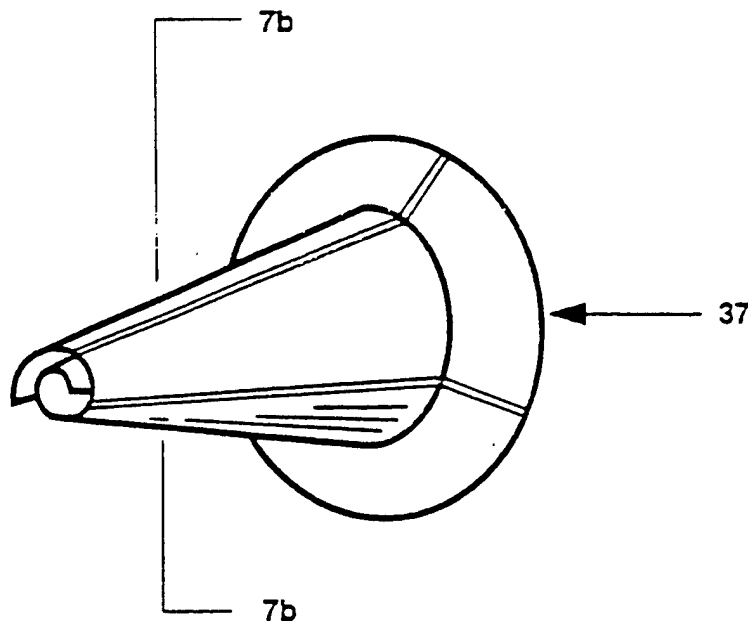

(b)

Figure 2. Patent concept (continued).

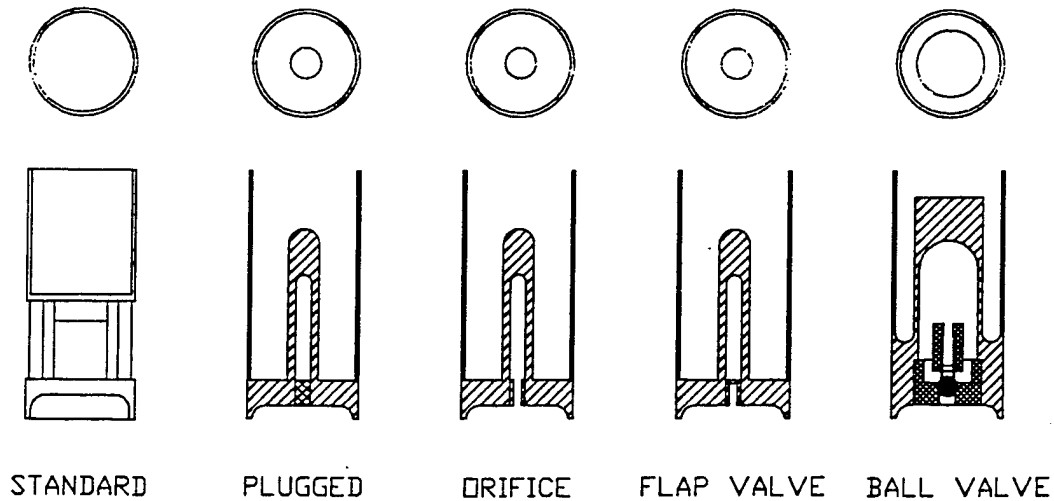

Figure 3. Shot cup designs.

factory-loaded shells and reloaded factory loads were tested to ensure the reloading was not affecting the shot spread. A cavity open to propulsion gas pressure was tested. A control test was performed with the orifice to the cavity plugged to determine if the cavity was being pressurized. A simple flap valve design was produced to capture the peak pressure reached within the cavity of the shot cup. This design was tried as a simple low-cost method of including a check valve mechanism. In order to prove the principle of the concept, ARL designed and tested another shot cup utilizing a ball check valve with a seating spring and much greater orifice area. The details of this design are shown in Figure 4. Additionally, in this shot cup, the shot cup volume (and hence the amount of shot) was reduced to ensure that the pressurized cavity would force the shot against the fingers of the shot cup and therefore against the gun bore. All of the ARL shot cups were fabricated in-house from low-density polyethylene stock. Low-density polyethylene has good strength and ductility properties, but was chosen primarily because it can be bonded and welded. Some attempts were made with various adhesives to create strong bonds with the polyethylene, but the structural integrity of the bonds was not satisfactory. Welding the polyethylene worked much better than the adhesives tried. The plastic orifices, plugs, and valves were welded to the shot cup (and the ball valve assembly was welded together) using a small pencil-type soldering iron.

3. Method of Testing

Factory-loaded federal 12-gauge shotgun shells with 1 1/4 oz of no. 7 1/2 shot were taken apart to obtain the powder and the shot. The original components (shot and shot cup), as well as the shot cups to be tested, were weighed. The powder was

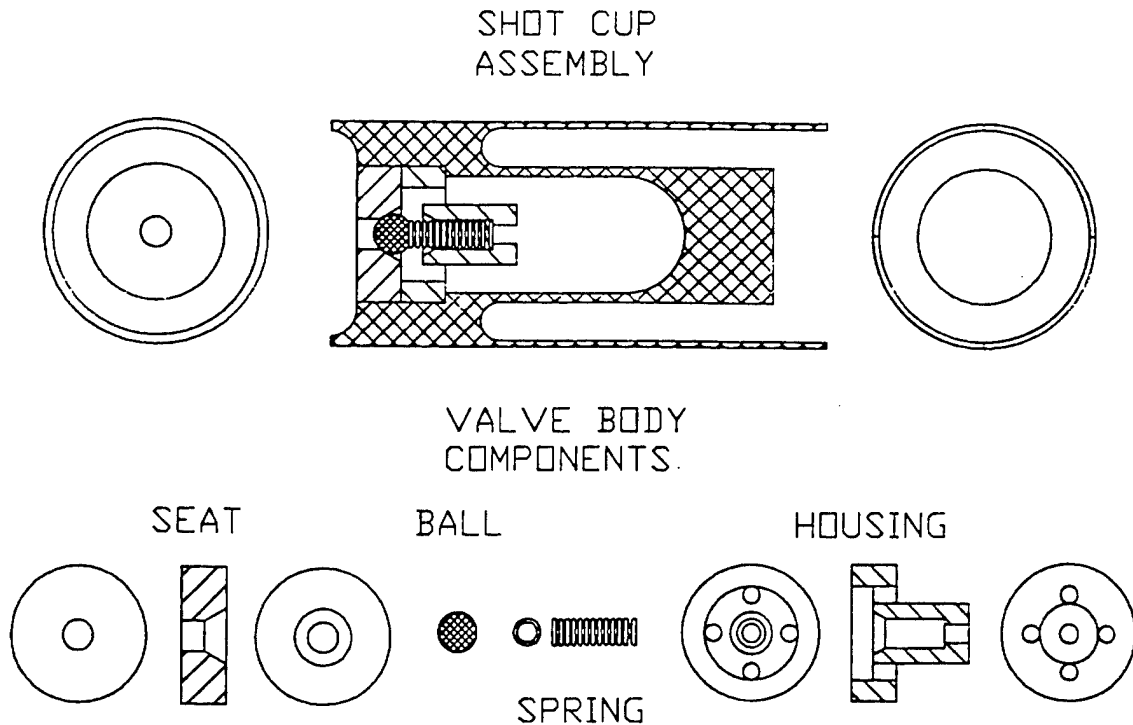

Figure 4. Ball check valve design.

reloaded into new primed cases along with the shot cup being tested and the proper amount of shot to make the weight of the test shot cup and shot equal to the weight of the original shot cup and full load of shot. The shot shells were assembled and crimped using an MEC model 8447-600 Jr. Mark V shot shell reloader.

The shot shells were fired from a Remington 20-in (508-mm) barrel pump feed "riot" shotgun at brown paper "witness" targets located 15 ft (4.572 m) from the gun's muzzle. For each test, a single round was loaded into the shotgun and fired. The gun was mounted to a hard stand and fired remotely with a lanyard.

The paper targets were marked with the test number and target orientation and removed after each shot. The extreme vertical and horizontal spreads were measured and recorded.

4. Results

The efforts of H. P. White were a departure from the internally pressurized shot cup. Its efforts, in an attempt to simplify the concept, focused on variations of internal obstructions to the shot column, to create a radial component to the shot pellet velocity. There was no pressurization within the shot cups. Figure 5 shows the shapes of the inserts tested. H. P. White used a 30-in-long (762-mm) barrel with a

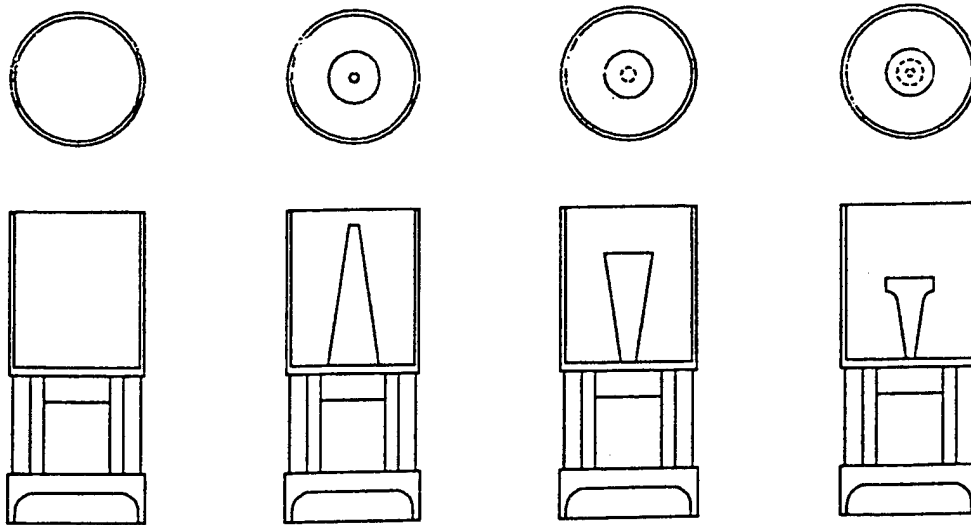

Figure 5. H. P. White insert configurations.

full choke. Chokes are described in Appendix C. They also fired at targets that were 15 ft (4.572 m) from the muzzle. The resulting patterns were all inscribed by a 18-in-diameter (457-mm) circle, well below the desired shot spread. However, it is more noteworthy that although an increase in shot pattern size was achieved, it was at the expense of inline, or axial, energy. Many pellets struck, but did not penetrate the paper target located 15 ft (4.57 m) from the gun muzzle, dramatically revealing their ineffectiveness.

ARL's control shot shell and initial cavity designs produced average pattern spreads of 9.5 × 9.5 in (240 × 240 mm). The damage sustained by the shot cups indicated that the internal cavity was being pressurized (Figure 6), but the impact data revealed this pressurization was not enough to increase the shot pattern size. Damage to plugged cavity shot cups indicated that the unplugged cavities had been pressurized. Table 1 lists the firing results of the various tests. All spreads were, statistically, equal in the vertical and horizontal directions.

The shot cups with the flap check valve design did not produce impact results different from the open orifice designs. This indicated that either the valve was not functioning properly, or the orifice size was insufficient to allow pressurization of the cavity during the ballistic cycle, or both.

The ball check valve design produced patterns with an average spread of 27 × 27 in (686 × 686 mm). Unfortunately, this was still only about half of the desired shot spread.



BALL VALVE

ORIFICE

PLUGGED

STANDARD

Figure 6. Damage to shot cups.

Table 1. ARL shot spread results.

Shot Cup	Spread (mm) [in]	Remarks
As-received Federal shells	240 [9.5]	—
Reloaded Federal shells	240 [9.5]	Same as previous case.
Pressure tube	240 [9.5]	Some damage to pressure tube wall.
Pressure tube with flap valve	240 [9.5]	No significant difference from previous case.
Pressure tube plugged	240 [9.5]	Reduced damage to pressure tube wall.
Ball valve	686 [27]	Pressure cavity ends failed.

5. Discussion

To achieve the desired pattern, a cavity pressure of approximately 5000–6000 psi (34.5–41.4 MPa) must be achieved and maintained to muzzle exit. The current design fabricated from low-density polyethylene fails around 1200 psi (8.3 MPa) (as

determined from shot spread results and later by finite element analyses). Finite element analysis indicates a redesign may provide about 2500 psi (17.2 MPa) capability. Side wall failures of the cavity dominate the ultimate pressure that can be contained and the loading upon the shot. In order to achieve the desired pressure loading on the shot, greater support of the cavity wall while maintaining loading on the shot pellets must be achieved. It is believed that this could be most easily achieved using another material. A material with high strain to failure capabilities—like an elastomer that could expand out against the shot stack and cup wall—would be desirable. Applying the gas pressure for all practical purposes directly against the shot would be the best solution.

6. Conclusions

A shot cup was designed and tested, which substantially increased the size of the shot impact pattern, utilizing only the propulsion gases as the activation mechanism. While the increase in pattern size is not as great as might be desired, a solid basis for the concept has been demonstrated. It is the belief of the investigators that further investigation into the use of the proper materials will produce an economical and technical solution to provide the desired performance.

7. Recommendations

It is highly desirable that the design of the shot cup be as inexpensive and highly manufacturable as possible. Further development of this concept is needed to provide the final pieces of the puzzle to put the close-combat shot shell into the fielded arsenal of our soldiers in the field.

INTENTIONALLY LEFT BLANK.

Appendix A. Effectiveness of Shot Spread

Because a shotgun produces about five times the muzzle energy of pistols with enough energy to kill people, it seems reasonable to think the shotgun should be an effective weapon against more than one person per shot. The intent of this study is to spread the shot pattern from a shot shell sufficiently to inflict great harm on a large area at very short range. In order to determine what area would be desirable to cover, the available energy of a shot shell was evaluated. Consider the following data.

Examples of near-muzzle energies:¹

- .22 Short (pistol): 27 gr, 1035 ft/s—64 ft·lb (87 N·m),
- .38 Special (pistol): 158 gr, 910 ft/s—290 ft·lb (393 N·m),
- 9-mm (pistol): 115 gr, 1145 ft/s—334 ft·lb (453 N·m),
- .45 (pistol): 230 gr, 845 ft/s—364 ft·lb (493 N·m),
- .357 Mag. (pistol): 158 gr, 1220 ft·lb—521 ft·lb (707 N·m), and
- 12-gauge shotgun: 1 1/4-oz shot, 1165 ft/s—1646 ft·lb (2232 N·m).

While a .22 pistol can kill someone, particularly at close range, law enforcement agencies typically use .38 special or greater energy handguns. Let 300 ft·lb be the target energy. Consider the following: There is 1646 ft·lb available in a shot shell. At 300 ft·lb/target, there is sufficient energy to strike five targets.

For BB shot, 1 1/4 oz (0.567 g) is about 63 pellets. This yields about 26 ft·lb/pellet available; therefore, to inflict serious injury, at least 12 pellets should impact the target.

For no. 0 shot, 1 1/4 oz (0.567 g) is about 11 pellets. This yields about 150 ft·lb/pellet available; therefore, to inflict serious injury, at least two pellets should impact the target.

For a soldier-sized target, 1.5×1.5 ft or 2.25 ft², the pellet area density should be at least 300 ft·lb energy on 2.25 ft².

The total area covered would be five targets \times 2.25 ft²/target or 11.25 ft², an area 3.4×3.4 ft. At 15 ft, this would require a half angle equal to $\arctan(3.4/2/15)$ or $\pm 8.1^\circ$.*

¹Sporting Arms and Ammunition Manufacturer's Institute. New York, NY. 1982.

*To achieve $\pm 8.1^\circ$ for BB shot would require a pressure of $8.1/8.5 \times 5572$ or 5310 psi (see Appendix B).

Any further increase in shot spread would significantly decrease the probability of inflicting a serious injury to any given target.

A design goal of 5000 psi was chosen as it would provide a wide pattern spread while increasing the probability of striking the target areas with sufficient impact energy to inflict serious damage. This would yield a half angle of $\pm 7.6^\circ$ and cover an area 48×48 in.

Appendix B. Shot Spread via Pressurization

For these calculations, the assumptions are that the distance from the weapon to the target is 15 ft (4.57 m), a soldier-sized target is 18 in (457 mm) wide, and muzzle velocity is 1275 ft/s.

Shot spread:

To get a three-man width area target from 15 ft (4.57 m):

- Width: ± 2.25 ft (2.29 m) and
- Half angle = $\arctan(2.5/15) = 8.5^\circ$.

To achieve this spread, $\arctan(V_r/V_z) = 8.5^\circ$, where V_r = radial velocity, V_z = muzzle velocity = 1275 ft/s (389 m/s), thus, $V_r = 191$ ft/s (58 m/s).

To achieve this via pressure loading:

The approximate time for the wad to clear the muzzle is $(0.8 \text{ in} / 12 \text{ in/ft}) / 1,275 \text{ ft/s} = 0.0000523 \text{ s} = T$. Therefore, assume radial acceleration = $191 \text{ ft/s} / T = 3,652,875 \text{ ft/s}^2$ or $113,443 \text{ g}'s$.

A BB shot is about 0.09 in (2.29 mm) in radius with a weight of 0.00125 lb (0.567 g). Therefore, it requires about 142 lb (632 N) to accelerate it to $113,443 \text{ g}'s$. Using the shot's cross-sectional area, (0.0254 in²) a pressure of 5573 psi (38.4 MPa) would be required to achieve this force. (Muzzle pressure normally is about 1000 psi [6.9 MPa].)

This calculation, of course, assumes that the force from the pressure loading acts in a purely radial direction.

A design goal of 5000 psi (34.5 MPa) was chosen as it would provide a wide pattern spread while increasing the probability of striking the target areas with sufficient impact energy to inflict serious damage to the targets (see Appendix A).

INTENTIONALLY LEFT BLANK.

Appendix C. Shotgun Terminology

Shotgun types:¹

Gauge	Diameter of Bore (in)
10	0.775
12	0.729
16	0.662
20	0.615
.410	0.410

Chokes:

Constriction of barrel diameter at muzzle. They typically vary from 0.003–0.040 in. Choke rating is based on percentage of shot within a 30-in-diameter circle shot at a range of 40 yd (30 yd for .410 shotgun).

- Full choke > 70%,
- Improved modified choke: 60–70%,
- Modified choke: 55–60%,
- Improved cylinder (also quarter choke): 45–50%, and
- Cylinder bore (no choke): 30–40%.

To measure choke, shoot a target at range (30 or 40 yd as appropriate), draw a 30-in-diameter circle around the greatest number of shot holes, determine the total number of shot holes and the number within the circle, calculate the percentage, determine choke rating. Note that the shell, particularly the crimp, will affect the choke rating, so actual choke is not a factor of the barrel alone.

It is the opinion of this author that the idea of the choke is to allow for greater range shooting as the spread is reduced.

¹O'Connor, J. *Complete Book of Shooting*. NY: Times Mirror Magazines, Inc., 1965.

INTENTIONALLY LEFT BLANK.

<u>NO. OF COPIES</u>	<u>ORGANIZATION</u>
2	DEFENSE TECHNICAL INFORMATION CENTER DTIC OCA 8725 JOHN J KINGMAN RD STE 0944 FT BELVOIR VA 22060-6218
1	HQDA DAMO FDT 400 ARMY PENTAGON WASHINGTON DC 20310-0460
1	OSD OUSD(A&T)/ODDR&E(R) DR R J TREW 3800 DEFENSE PENTAGON WASHINGTON DC 20301-3800
1	COMMANDING GENERAL US ARMY MATERIEL CMD AMCRDA TF 5001 EISENHOWER AVE ALEXANDRIA VA 22333-0001
1	INST FOR ADVNCD TCHNLGY THE UNIV OF TEXAS AT AUSTIN 3925 W BRAKER LN STE 400 AUSTIN TX 78759-5316
1	US MILITARY ACADEMY MATH SCI CTR EXCELLENCE MADN MATH THAYER HALL WEST POINT NY 10996-1786
1	DIRECTOR US ARMY RESEARCH LAB AMSRL D DR D SMITH 2800 POWDER MILL RD ADELPHI MD 20783-1197
1	DIRECTOR US ARMY RESEARCH LAB AMSRL CI AI R 2800 POWDER MILL RD ADELPHI MD 20783-1197

<u>NO. OF COPIES</u>	<u>ORGANIZATION</u>
3	DIRECTOR US ARMY RESEARCH LAB AMSRL CI LL 2800 POWDER MILL RD ADELPHI MD 20783-1197
3	DIRECTOR US ARMY RESEARCH LAB AMSRL CI IS T 2800 POWDER MILL RD ADELPHI MD 20783-1197
	<u>ABERDEEN PROVING GROUND</u>
2	DIR USARL AMSRL CI LP (BLDG 305)

<u>NO. OF COPIES</u>	<u>ORGANIZATION</u>
1	DIRECTOR US ARMY RESEARCH LAB AMSRL CP CA D SNIDER 2800 POWDER MILL RD ADELPHI MD 20783-1145
1	DIRECTOR US ARMY RESEARCH LAB AMSRL CI IS R 2800 POWDER MILL RD ADELPHI MD 20783-1145
3	DIRECTOR US ARMY RESEARCH LAB AMSRL OP SD TL 2800 POWDER MILL RD ADELPHI MD 20783-1145
1	DPTY ASST SECY FOR R&T SARD TT THE PENTAGON RM 3EA79 WASHINGTON DC 20301-7100
1	COMMANDER US ARMY MATERIEL CMD AMXMI INT 5001 EISENHOWER AVE ALEXANDRIA VA 22333-0001
4	COMMANDER US ARMY ARDEC AMSTA AR CC G PAYNE J GEHBAUER C BAULIEU H OPAT PICATINNY ARSENAL NJ 07806-5000
2	COMMANDER US ARMY ARDEC AMSTA AR AE WW E BAKER J PEARSON PICATINNY ARSENAL NJ 07806-5000
1	COMMANDER US ARMY ARDEC AMSTA AR FSE PICATINNY ARSENAL NJ 07806-5000

<u>NO. OF COPIES</u>	<u>ORGANIZATION</u>
1	COMMANDER US ARMY ARDEC AMSTA AR TD C SPINELLI PICATINNY ARSENAL NJ 07806-5000
6	COMMANDER US ARMY ARDEC AMSTA AR CCH A W ANDREWS S MUSALLI R CARR M LUCIANO E LOGSDEN T LOUZEIRO PICATINNY ARSENAL NJ 07806-5000
1	COMMANDER US ARMY ARDEC AMSTA AR CCH P J LUTZ PICATINNY ARSENAL NJ 07806-5000
1	COMMANDER US ARMY ARDEC AMSTA AR FSF T C LIVECCHIA PICATINNY ARSENAL NJ 07806-5000
1	COMMANDER US ARMY ARDEC AMSTA ASF PICATINNY ARSENAL NJ 07806-5000
1	COMMANDER US ARMY ARDEC AMSTA AR QAC T C C PATEL PICATINNY ARSENAL NJ 07806-5000
1	COMMANDER US ARMY ARDEC AMSTA AR M D DEMELLA PICATINNY ARSENAL NJ 07806-5000

<u>NO. OF COPIES</u>	<u>ORGANIZATION</u>
2	COMMANDER US ARMY ARDEC AMSTA AR FSP G M SCHIKSNIS D CARLUCCI PICATINNY ARSENAL NJ 07806-5000
1	COMMANDER US ARMY ARDEC AMSTA AR FSP A P KISATSKY PICATINNY ARSENAL NJ 07806-5000
2	COMMANDER US ARMY ARDEC AMSTA AR CCH C H CHANIN S CHICO PICATINNY ARSENAL NJ 07806-5000
1	COMMANDER US ARMY ARDEC AMSTA AR QAC T D RIGOGLIOSO PICATINNY ARSENAL NJ 07806-5000
1	COMMANDER US ARMY ARDEC AMSTA AR WET T SACHAR BLDG 172 PICATINNY ARSENAL NJ 07806-5000
1	US ARMY ARDEC INTELLIGENCE SPECIALIST AMSTA AR WEL F M GUERRIERE PICATINNY ARSENAL NJ 07806-5000

<u>NO. OF COPIES</u>	<u>ORGANIZATION</u>
9	COMMANDER US ARMY ARDEC AMSTA AR CCH B P DONADIA F DONLON P VALENTI C KNUTSON G EUSTICE S PATEL G WAGNECZ R SAYER F CHANG PICATINNY ARSENAL NJ 07806-5000
6	COMMANDER US ARMY ARDEC AMSTA AR CCL F PUZYCKI R MCHUGH D CONWAY E JAROSZEWSKI R SCHLENNER M CLUNE PICATINNY ARSENAL NJ 07806-5000
2	PEO FIELD ARTILLERY SYS SFAE FAS PM H GOLDMAN T MCWILLIAMS PICATINNY ARSENAL NJ 07806-5000
1	COMMANDER US ARMY ARDEC AMSTA AR WEA J BRESCIA PICATINNY ARSENAL NJ 07806-5000
1	COMMANDER US ARMY ARDEC PRODUCTION BASE MODERN ACTY AMSMC PBM K PICATINNY ARSENAL NJ 07806-5000

<u>NO. OF COPIES</u>	<u>ORGANIZATION</u>
1	DIRECTOR AIR FORCE RESEARCH LAB MLLMD D MIRACLE 2230 TENTH ST WRIGHT PATTERSON AFB OH 45433-7817
1	COMMANDER US ARMY ARDEC PLANS AND PROGRAM OFC AMSTA AR CCJ V SHISLER PICATINNY ARSENAL NJ 07806-5000
1	OFC OF NAVAL RESEARCH J CHRISTODOULOU ONR CODE 332 800 N QUINCY ST ARLINGTON VA 22217-5600
1	US ARMY CERL R LAMPO 2902 NEWMARK DR CHAMPAIGN IL 61822
2	HQ IOC TANK AMMUNITION TEAM AMSIO SMT R CRAWFORD W HARRIS ROCK ISLAND IL 61299-6000
2	COMMANDER US ARMY AMCOM AVIATION APPLIED TECH DIR J SCHUCK FT EUSTIS VA 23604-5577
1	BENET LABORATORIES AMSTA AR CCB E KATHE WATERVLIET NY 12189-4050
1	DIRECTOR US ARMY AMCOM SFAE AV RAM TV D CALDWELL BLDG 5300 REDSTONE ARSENAL AL 35898

<u>NO. OF COPIES</u>	<u>ORGANIZATION</u>
1	NAVAL SURFACE WARFARE CTR DAHLGREN DIV CODE G06 DAHLGREN VA 22448
1	US ARMY COLD REGIONS RSCH & ENGRNG LAB P DUTTA 72 LYME RD HANOVER NH 03755
1	USA SBCCOM PM SOLDIER SPT AMSSB PM RSS A J CONNORS KANSAS ST NATICK MA 01760-5057
2	USA SBCCOM MATERIAL SCIENCE TEAM AMSSB RSS J HERBERT M SENNETT KANSAS ST NATICK MA 01760-5057
2	OFC OF NAVAL RESEARCH D SIEGEL CODE 351 J KELLY 800 N QUINCY ST ARLINGTON VA 22217-5660
1	NAVAL SURFACE WARFARE CTR TECH LIBRARY CODE 323 17320 DAHLGREN RD DAHLGREN VA 22448
2	NAVAL SURFACE WARFARE CTR U SORATHIA C WILLIAMS CD 6551 9500 MACARTHUR BLVD WEST BETHESDA MD 20817
2	COMMANDER NAVAL SURFACE WARFARE CTR CARDEROCK DIVISION R PETERSON CODE 2020 M CRITCHFIELD CODE 1730 BETHESDA MD 20084

<u>NO. OF</u> <u>COPIES</u>	<u>ORGANIZATION</u>
8	DIRECTOR US ARMY NATIONAL GROUND INTELLIGENCE CTR D LEITER MS 404 M HOLTUS MS 301 M WOLFE MS 307 S MINGLEDORF MS 504 J GASTON MS 301 W GSTATTENBAUER MS 304 R WARNER MS 305 J CRIDER MS 306 220 SEVENTH ST NE CHARLOTTESVILLE VA 22091
1	NAVAL SEA SYSTEMS CMD D LIESE 2531 JEFFERSON DAVIS HWY ARLINGTON VA 22242-5160
1	NAVAL SURFACE WARFARE CTR M LACY CODE B02 17320 DAHLGREN RD DAHLGREN VA 22448
8	US ARMY SBCCOM SOLDIER SYSTEMS CENTER BALLISTICS TEAM J WARD W ZUKAS P CUNNIFF J SONG MARINE CORPS TEAM J MACKIEWICZ BUS AREA ADVOCACY TEAM W HASKELL AMSSB RCP SS W NYKVIST S BEAUDOIN KANSAS ST NATICK MA 01760-5019
1	EXPEDITIONARY WARFARE DIV N85 F SHOUP 2000 NAVY PENTAGON WASHINGTON DC 20350-2000
1	NASA LANGLEY RSCH CTR T GATES MS 188E HAMPTON VA 23661-3400

<u>NO. OF</u> <u>COPIES</u>	<u>ORGANIZATION</u>
7	US ARMY RESEARCH OFC A CROWSON H EVERETT J PRATER G ANDERSON D STEPP D KISEROW J CHANG PO BOX 12211 RESEARCH TRIANGLE PARK NC 27709-2211
1	AFRL MLBC 2941 P ST RM 136 WRIGHT PATTERSON AFB OH 45433-7750
1	AFRL MLSS R THOMSON 2179 12TH ST RM 122 WRIGHT PATTERSON AFB OH 45433-7718
2	AFRL F ABRAMS J BROWN BLDG 653 2977 P ST STE 6 WRIGHT PATTERSON AFB OH 45433-7739
1	AFRL MLS OL L COULTER 7278 4TH ST BLDG 100 BAY D HILL AFB UT 84056-5205
1	OSD JOINT CCD TEST FORCE OSD JCCD R WILLIAMS 3909 HALLS FERRY RD VICKSBURG MS 29180-6199
3	NASA LANGLEY RSCH CTR AMSRL VS W ELBER MS 266 F BARTLETT JR MS 266 G FARLEY MS 266 HAMPTON VA 23681-0001

<u>NO. OF</u> <u>COPIES</u>	<u>ORGANIZATION</u>
1	MARINE CORPS INTLLGNC ACTVTY D KOSITZKE 3300 RUSSELL RD STE 250 QUANTICO VA 22134-5011
1	DIRECTOR NATIONAL GRND INTLLGNC CTR LANG TMT 220 SEVENTH ST NE CHARLOTTESVILLE VA 22902-5396
1	DIRECTOR DEFENSE INTLLGNC AGENCY TA 5 K CRELLING WASHINGTON DC 20310
1	BATTELLE NATICK OPNS B HALPIN 209 W CENTRAL ST STE 302 NATICK MA 01760
1	ARMTEC DEFENSE PRODUCTS S DYER 85 901 AVE 53 PO BOX 848 COACHELLA CA 92236
1	NATIONAL COMPOSITE CENTER T CORDELL 2000 COMPOSITE DR KETTERING OH 45420
1	AAI CORPORATION T G STASTNY PO BOX 126 HUNT VALLEY MD 21030-0126
1	OFC DEPUTY UNDER SEC DEFNS J THOMPSON 1745 JEFFERSON DAVIS HWY CRYSTAL SQ 4 STE 501 ARLINGTON VA 22202

<u>NO. OF</u> <u>COPIES</u>	<u>ORGANIZATION</u>
4	UDLP R BRYNSVOLD P JANKE MS 170 4800 EAST RIVER RD MINNEAPOLIS MN 55421-1498
	<u>ABERDEEN PROVING GROUND</u>
1	DIRECTOR US ARMY RESEARCH LAB AMSRL OP AP L APG MD 21005-5066
4	DIR USATC STEAC AE CA D GRIFFIN STEAC FC M A ROSE G NIEWENHOUS G BREWER APG MD 21005
53	DIR USARL AMSRL CI AMSRL CI S A MARK AMSRL CS IO FI M ADAMSON AMSRL SL BA AMSRL SL BL D BELY R HENRY AMSRL SL BG AMSRL SL I AMSRL WM J SMITH AMSRL WM B A HORST

NO. OF
COPIES ORGANIZATION

ABERDEEN PROVING GROUND (CONT)

AMSRL WM BA
D LYON
AMSRL WM BC
P PLOSTINS
J NEWILL
S WILKERSON
AMSRL WM BE
C LEVERITT
AMSRL WM BF
J LACETERA
AMSRL WM M
D VIECHNICKI
AMSRL WM MA
L GHIORSE
S MCKNIGHT
AMSRL WM MB
B FINK
J BENDER
T BOGETTI
R BOSSOLI
L BURTON
K BOYD
S CORNELISON
P DEHMER
R DOOLEY
W DRYSDALE
G GAZONAS
S GHIORSE
D GRANVILLE
D HOPKINS
C HOPPEL
D HENRY
R KASTE
M KLUSEWITZ
M LEADORE
R LIEB
E RIGAS
J SANDS
D SPAGNUOLO
W SPURGEON
J TZENG
E WETZEL
A FRYDMAN

NO. OF
COPIES ORGANIZATION

ABERDEEN PROVING GROUND (CONT)

AMRSL WM MC
J MONTGOMERY
AMSRL WM T
B BURNS
AMSRL WM TC
R COATES
AMSRL WM TD
T HADUCH
T MOYNIHAN
AMSRL WM TE
A NIILER
J POWELL

INTENTIONALLY LEFT BLANK.

REPORT DOCUMENTATION PAGE

Form Approved
OMB No. 0704-0188

Public reporting burden for this collection of information is estimated to average 1 hour per response, including the time for reviewing instructions, searching existing data sources, gathering and maintaining the data needed, and completing and reviewing the collection of information. Send comments regarding this burden estimate or any other aspect of this collection of information, including suggestions for reducing this burden, to Washington Headquarters Services, Directorate for Information Operations and Reports, 1215 Jefferson Davis Highway, Suite 1204, Arlington, VA 22202-4302, and to the Office of Management and Budget, Paperwork Reduction Project(0704-0188), Washington, DC 20503.

1. AGENCY USE ONLY (Leave blank)

2. REPORT DATE

March 2002

3. REPORT TYPE AND DATES COVERED

Final, March 1994–November 1998

4. TITLE AND SUBTITLE

Close-Quarters Combat Shot Shell

5. FUNDING NUMBERS

622618AH80

6. AUTHOR(S)

Robert P. Kaste

7. PERFORMING ORGANIZATION NAME(S) AND ADDRESS(ES)

U.S Army Research Laboratory
ATTN: AMSRL-WM-MB
Aberdeen Proving Ground, MD 21005-5069

8. PERFORMING ORGANIZATION
REPORT NUMBER

ARL-TR-2692

9. SPONSORING/MONITORING AGENCY NAMES(S) AND ADDRESS(ES)

10. SPONSORING/MONITORING
AGENCY REPORT NUMBER

11. SUPPLEMENTARY NOTES

12a. DISTRIBUTION/AVAILABILITY STATEMENT

Approved for public release; distribution is unlimited.

12b. DISTRIBUTION CODE

13. ABSTRACT (Maximum 200 words)

The theory and design for a shot shell that produces a wider-than-standard shot spread are described. The technique implemented utilizes the pressure generated by the propulsion charge to apply radial force on the shot column within the shotgun barrel, causing an increase in shot divergence upon exit from the weapon. The increase in shot pattern size is intended for application of the shotgun as an area weapon for close-quarter applications, which might occur in military operations on urban terrain (MOUT) or civilian policing operations.

14. SUBJECT TERMS

shotgun shell, area weapon, close-quarter, dispersion

15. NUMBER OF PAGES

27

16. PRICE CODE

17. SECURITY CLASSIFICATION
OF REPORT

UNCLASSIFIED

18. SECURITY CLASSIFICATION
OF THIS PAGE

UNCLASSIFIED

19. SECURITY CLASSIFICATION
OF ABSTRACT

UNCLASSIFIED

20. LIMITATION OF ABSTRACT

UL

INTENTIONALLY LEFT BLANK.