

CECW-EH-D Engineer Manual 1110-2-1610	Department of the Army U.S. Army Corps of Engineers Washington, DC 20314-1000	EM 1110-2-1610 10 July 1989
	Engineering and Design HYDRAULIC DESIGN OF LOCK CULVERT VALVES	
	Distribution Restriction Statement Approved for public release; distribution is unlimited.	

Report Documentation Page

Report Date 10 Jul 1989	Report Type N/A	Dates Covered (from... to) -
Title and Subtitle Hydraulic Design of Lock Culvert Valves	Contract Number	
	Grant Number	
	Program Element Number	
Author(s)	Project Number	
	Task Number	
	Work Unit Number	
Performing Organization Name(s) and Address(es) Department of the Army U.S. Army Corps of Engineers Washington, DC 20314-1000	Performing Organization Report Number EM1110-2-1610	
Sponsoring/Monitoring Agency Name(s) and Address(es)	Sponsor/Monitor's Acronym(s)	
	Sponsor/Monitor's Report Number(s)	
Distribution/Availability Statement Approved for public release, distribution unlimited		
Supplementary Notes		
<p>Abstract</p> <p>The purpose of this manual is to present data accrued from experience and research that may be useful to Corps of Engineers hydraulic designers concerned with the design of control valves for navigation lock filling and emptying systems. Primarily, the objective is to consider the hydrodynamic forces that enter into the design of valves. However, the interrelationship of structural features, operational procedures, and hydraulic performance will be discussed when pertinent to an understanding of the problems involved. Consideration will be given only to valves used to control flow in relatively long culverts. Valves in tubes with a length less than about 5 diameters, such as might be installed in or around the lock service gates, present a somewhat different type of design problem than those installed in longer culverts;, and since they are rarely used in any but very low-lift modern locks, they will be omitted from the discussion. Service gates which in themselves either constitute the primary filling system or are used as auxiliary devices, such as vertical-lift gates, tainter gates, sector gates, bascule gates, etc., also will not be treated in this manual.</p>		
Subject Terms		
Report Classification unclassified	Classification of this page unclassified	

Classification of Abstract unclassified	Limitation of Abstract UU
Number of Pages 59	

ENGINEER MANUAL

EM 1110-2-1610
15 AUGUST 1975

ENGINEERING AND DESIGN

HYDRAULIC DESIGN OF
LOCK CULVERT VALVES



DEPARTMENT OF THE ARMY•CORPS OF ENGINEERS
OFFICE OF THE CHIEF OF ENGINEERS

DEPARTMENT OF THE ARMY
Office of the Chief of Engineers
Washington, D. C. 20314

EM 1110-2-1610

DAEN-CWE-H

Engineer Manual
No. 1110-2-1610

15 August 1975

Engineering and Design
HYDRAULIC DESIGN OF LOCK CULVERT VALVES

1. Purpose. The purpose of this manual is to present hydraulic design data on control valves for navigation lock filling and emptying systems.
2. Applicability. This manual applies to all field operating agencies concerned with Civil Works design, construction, and operational maintenance.
3. General. This manual is a guide in the design of control valves for navigation lock filling and emptying systems.

FOR THE CHIEF OF ENGINEERS:

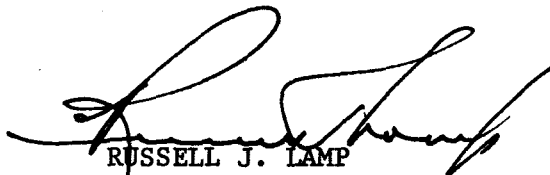

RUSSELL J. LAMP
Colonel, Corps of Engineers
Executive

DAEN-CWE-H

Engineer Manual
No. 1110-2-1610

15 August 1975

ENGINEERING AND DESIGN
Hydraulic Design of Lock Culvert Valves

Table of Contents

<u>Subject</u>	<u>Paragraph</u>	<u>Page</u>
CHAPTER 1. INTRODUCTION		
Purpose-----	1-1	1-1
Applicability-----	1-2	1-1
References-----	1-3	1-1
Typical Filling and Emptying System-----	1-4	1-3
Types of Lock Valves-----	1-5	1-3
CHAPTER 2. AIR IN CULVERT SYSTEMS		
Experience with Air in Culvert System-----	2-1	2-1
Recent Field Tests of Cavitation Conditions-----	2-2	2-2
Selection of Elevation for Culvert Valves---	2-3	2-3
Conclusions and Recommendations Regarding Admission of Air into Culvert System-----	2-4	2-6
Design of Air Vents-----	2-5	2-7
CHAPTER 3. HOIST LOADS		
Hoist Loads due to Flowing Water-----	3-1	3-1
Tainter Valves-----	3-1a	3-1
Interpretation of Data-----	3-1b	3-1
Horizontally Framed Valve-----	3-1c	3-1
Double Skin-Plate Valve-----	3-1d	3-9
Vertically Framed Valve-----	3-1e	3-9
General Comments-----	3-1f	3-10
Total Hoist Loads-----	3-2	3-11
Peak Head Across Valve-----	3-3	3-11
CHAPTER 4. VALVE SEALS		
General-----	4-1	4-1
Bottom Seals-----	4-2	4-1
Side Seals-----	14-3	4-1
Top Seals-----	4-4	4-1

EM 1110-2-1610
15 Aug 75

<u>Subject</u>	<u>Paragraph</u>	<u>Page</u>
CHAPTER 5. RECESSES FOR UNWATERING BULKHEADS		
General-----	5-1	5-1
Bulkhead Recesses-----	5-2	5-1
Location of Bulkhead Recesses-----	5-3	5-1
APPENDIX A. CAVITATION AT LOCK CULVERT VALVES-----		A-1
APPENDIX B. LOCK FILLING PROGRAM-----		B-1
APPENDIX C. DESIGN EXAMPLES-----		C-1

CHAPTER 1. INTRODUCTION

1-1. Purpose. The purpose of this manual is to present data accrued from experience and research that may be useful to Corps of Engineers hydraulic designers concerned with the design of control valves for navigation lock filling and emptying systems. Primarily, the objective is to consider the hydrodynamic forces that enter into the design of valves. However, the interrelationship of structural features, operational procedures, and hydraulic performance will be discussed when pertinent to an understanding of the problems involved. Consideration will be given only to valves used to control flow in relatively long culverts. Valves in tubes with a length less than about 5 diameters, such as might be installed in or around the lock service gates, present a somewhat different type of design problem than those installed in longer culverts; and since they are rarely used in any but very low-lift modern locks, they will be omitted from the discussion. Service gates which in themselves either constitute the primary filling system or are used as auxiliary devices, such as vertical-lift gates, tainter gates, sector gates, bascule gates, etc., also will not be treated in this manual.

1-2. Applicability. The provisions of this manual are applicable to Corps of Engineers Divisions and Districts concerned with civil works design, construction, and operational maintenance.

1-3. References.

- a. Pickett, E. B., "Hydraulic Prototype Tests of Tainter Valve, McNary Lock, Columbia River, Washington," Technical Report No. 2-552, Jun 1960, U. S. Army Engineer Waterways Experiment Station, CE, P. O. Box 631, Vicksburg, Mississippi 39180.
- b. U. S. Army Engineer Waterways Experiment Station, CE, "Vacuum Tank Tests of Model Tainter Valve for McNary Dam," Technical Memorandum No. 2-282, Jun 1949, Vicksburg, Miss.
- c. U. S. Army Engineer Waterways Experiment Station, CE, "John Day Tests" (in preparation), Vicksburg, Miss.
- d. Fidelman, S., "Filling and Emptying Systems for Walter F. George Lock, Chattahoochee River, Alabama-Georgia; Hydraulic Model Investigation," Hydraulic Laboratory Report No. 73, Sep 1961, U. S. Army Engineer District, St. Paul, St. Paul, Minn.; prepared by St. Anthony Falls Hydraulic Laboratory, 3625 22nd Avenue, Minneapolis, Minn. 55407.

15 Aug 75

- e. Ables, J. H., Jr., "Intake Studies, Dardanelle Lock, Arkansas River, Arkansas; Hydraulic Model Investigation," Technical Report No. 2-573, Jul 1961, U. S. Army Engineer Waterways Experiment Station, CE, Vicksburg, Miss.
- f. Ables, J. H., Jr., and Murphy, T. E., "Culvert Tainter Valves, New Lock-Nom. 19, Mississippi River; Hydraulic Model Investigation," Technical Report No. 2-537, Jun 1961, U. S. Army Engineer Waterways Experiment Station, CE, Vicksburg, Miss.
- g. Ables, J. H., Jr., and Schmidt Gall, T., "Filling and Emptying System, New Poe Lock, St. Marys River, Sault Ste. Marie, Michigan; Hydraulic Model Investigation," Technical Report No. 2-561, Apr 1961, U. S. Army Engineer Waterways Experiment Station, CE, Vicksburg, Miss.
- h. Murphy, T. E. and Ables, J. H., Jr., "Lock Filling and Emptying System, Holt Lock and Dam, Warrior River, Alabama; Hydraulic Model Investigation," Technical Report No. 2-698, Nov 1965, U. S. Army Engineer Waterways Experiment Station, CE, Vicksburg, Miss.
- i. U. S. Army Engineer District, Portland, "Navigation Lock for McNary Dam, Columbia River, Oregon and Washington; Hydraulic Model Investigation," Report No. 26-1, May 1955, Portland, Oreg.; prepared by North Pacific Division Hydraulic Laboratory, Bonneville, Oregon 97008.
- j. Fidelman, S., "Filling and Emptying Systems for Barkley Lock, Cumberland River, Kentucky; Hydraulic Model Investigation," Hydraulic Laboratory Report No. 75, Jun 1963, U. S. Army Engineer District, St. Paul, St. Paul, Minn.; prepared by St. Anthony Falls Hydraulic Laboratory, Minneapolis, Minn.
- k. U. S. Army Engineer Waterways Experiment Station, CE, "Barkley Prototype Tests" (in preparation), Vicksburg, Miss.
- l. Ables, J. H., Jr., and Boyd, M. B., "Filling and Emptying System, Cannelton Main Lock, Ohio River, and Generalized Tests for Sidewall Port Systems for 110- by 1200-ft Locks; Hydraulic Model Investigation," Technical Report No. 2-713, Feb 1966, U. S. Army Engineer Waterways Experiment Station, CE, Vicksburg, Miss.
- m. American Society of Civil Engineers, "Manual on Lock Valves,"

15 Aug 75

Manuals of Engineering Practice No. 3, 1930, Committee on Lock Valves, Waterways Division, New York, N. Y.

- n. Murphy, T. E., "Hydraulic Model Investigation of Lock Culvert Valves," Jan 1942, Special Engineering Division, Panama Canal Zone, Diablo Heights, Canal Zone.

1-4. Typical Filling and Emptying System. The most common type of filling and emptying system used in modern locks has a longitudinal culvert in each lock wall extending from the upper pool to the lower pool, with a streamlined intake at the upstream end and a diffusion device at the downstream end. Flow is distributed from the longitudinal culverts in and out of the lock chamber by short ports or secondary culverts in the floor of the lock chamber. Two valves are required in each longitudinal culvert, one between the intake and the lock chamber manifold to release flow in the filling operation, and the other between the chamber manifold and the discharge diffuser to empty the lock chamber.

1-5. Types of Lock Valves.

a. In 1930 the American Society of Civil Engineers published a manual on lock culvert valves which described valves at 12 projects, "all of reasonably recent construction." At these 12 projects, seven types of valves were used, namely stoney gate, cylindrical, wagon body, butterfly, spool, slide gate, and tainter. However, since about 1930, tainter valves (an adaptation of the tainter gate developed by Jeremiah B. Tainter and patented by him in 1885 for control of flows over spillway crests) have been used almost exclusively in hydraulic systems of major locks in North America. Among the first locks in which tainter valves were used are Lock No. 2 on the Mississippi River, completed in 1930, and the Welland Ship Canal Locks in Canada, completed in 1933. The valves in these and several other installations were oriented in the manner of the conventional tainter gate, that is, with the trunnions downstream of the skin plate causing the convex surface of the skin plate to face the flow and seal along the upstream end of the valve well. When the Pickwick Lock on the Tennessee River was being designed for a lift of 65 ft, model tests showed that during the opening period the pressure gradient immediately downstream of the valve skin plate dropped below the top of the culvert; this caused large volumes of air to be drawn down the valve well and into the culvert. The air formed large pockets in the model culvert which restricted the flow until sufficient pressure was developed to expel the air through the ports or into the downstream bulkhead recess. Air expelled through the ports erupted at the water surface in the lock chamber with considerable violence, causing disturbances that would be hazardous to small craft.

15 Aug 75

b. By reversing the tainter valves, that is, placing the trunnions upstream of the skin plate with the convex surface of the skin plate facing downstream and sealing against the downstream end of the valve well, air was prevented from entering the culvert at the valve recess. A typical reverse tainter valve installation is shown in figure 1-1. Valves of this general type have been used on all major locks constructed by the Corps of Engineers in recent years.

c. Since data collected in the past 40 years have been concerned with reverse tainter valves, this type of valve will be used in examples in this manual. The reverse tainter valve certainly has proved very satisfactory, it probably will be desirable at most new projects, and its continued use is advocated. However, the designer should consider other types of valves. For instance, if submergence is such that air definitely will not be drawn down the valve well and into the culvert, the use of a tainter valve in the normal position may prove desirable. With the valve in the normal position, loads and load variations on the valve hoist caused by flowing water will be negligible.ⁿ Structural-design of the trunnion anchorages probably would be simplified. Further, depending upon whether the position of the valve in the lock wall is upstream or downstream from the lock gate, use of the normal position for the tainter valve may prevent large differentials between the water in the valve well and the lock chamber or lower pool. Also, vertical-lift gates which are used extensively in outlet conduits should be suitable as lock culvert valves. The vertical-lift valve would not require the large recess that is necessary with a tainter valve. With one spare gate at an installation, maintenance could be performed without taking the culvert out of service as is necessary with the tainter valve. However, the vertical-lift valve's rollers, wheels, or sliding surfaces might require considerably more servicing than do the elements of the tainter valve. If a vertical-lift valve is considered, certain of the procedures given in this manual could be used in design; but it is suggested that model tests be conducted to develop an optimum bottom shape for the gate and to determine valve hoist loads.

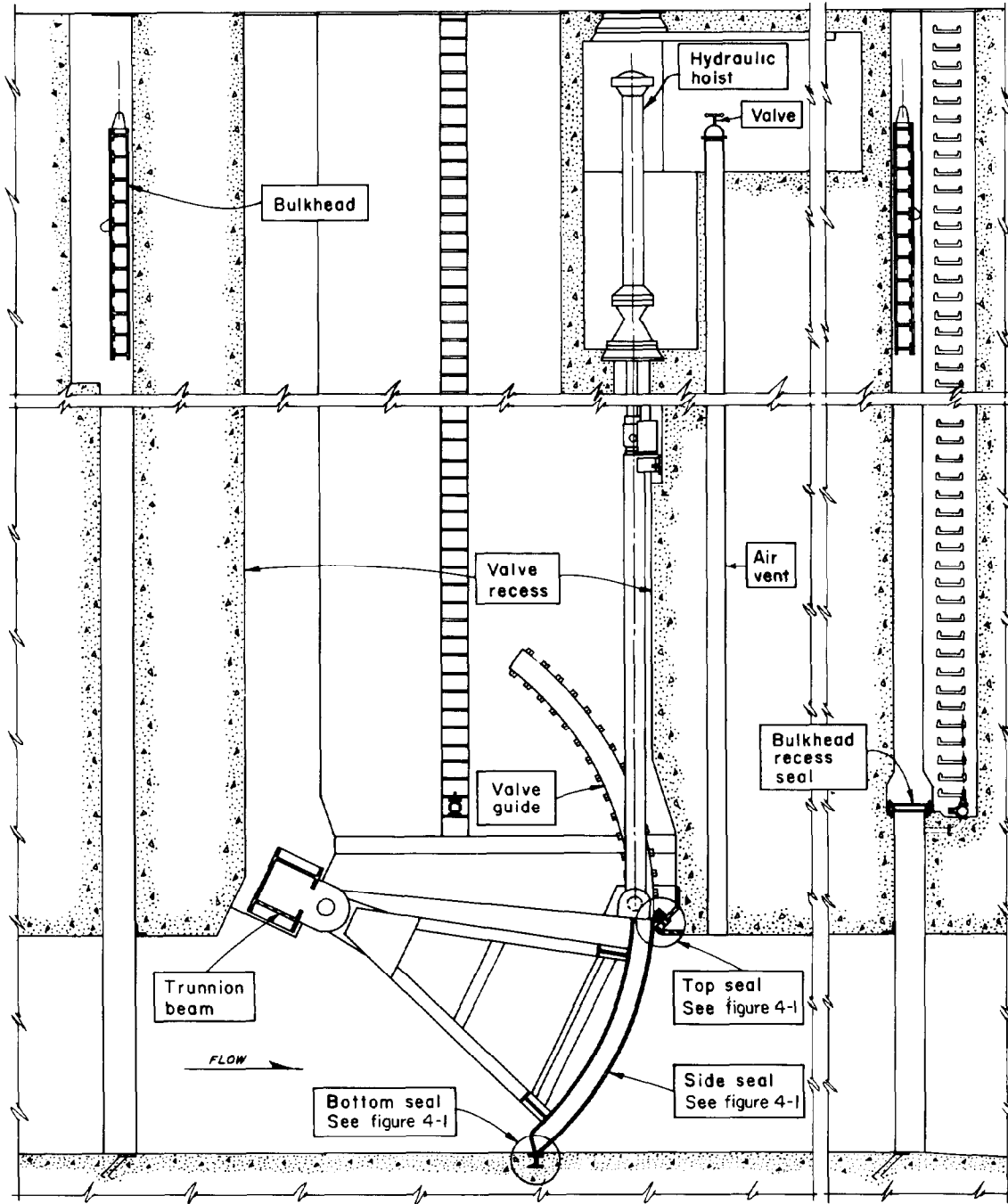

Figure 1-1. Typical reverse tainter valve installation

CHAPTER 2. AIR IN CULVERT SYSTEMS

2-1. Experience with Air in Culvert System.

a. At several old locks (notably Ohio River Lock No. 41, old Wilson Locks on the Tennessee River, and Mississippi River Lock No. 1) portions of the roofs of the culverts between the filling and emptying valves were at elevations higher than the lower pool. This resulted in air seeping into the culvert system and forming pockets along the roof when the chamber water surface was at lower pool level. In the filling operation, the air pockets were compressed and forced along the culvert until expelled through an available exit (valve well, bulkhead recess, or ports into the lock chamber). The air emerged with such explosive force that it endangered personnel on the lock walls, created disturbances in the chamber which were hazardous to small craft, and increased hawser forces on moored tows. Conditions at these locks were mitigated somewhat by installation of blowoff vents, but it was concluded that all air should be sealed from the filling system.

b. When the 92-ft-lift McNary Lock^a was constructed on the Columbia River six 12-in.-diam air vents, two in the culvert roof and two in the upper portion of each sidewall, were installed immediately downstream of each valve. During initial operation of the lock, the air vents at the filling valves were capped. Pounding noises, resembling thunder or cannon shots, seemed to come from the bulkhead slots on the downstream sides of the filling valves when the valves were partially open. It was found that opening one of the 12-in.-diam air vents in the roof of the culvert at each valve virtually eliminated these noises. Consequently, the lock has been operated with one air vent open at each valve. Air is drawn through the vent into the culvert system during the valve opening period, is entrained as small bubbles in the highly turbulent flow, and emerges in the lock chamber so entrained that it merely causes the water to look milky. When the valve reaches the full open position, air ceases to be drawn through the vent and all air is rapidly purged from the culvert system still entrained in the flow as small bubbles. No operation difficulties or hazardous conditions have resulted from admitting this controlled amount of air to the culvert system during the valve opening period. Other locks, notably the 63.6-ft-lift Holt Lock on the Warrior River and the 48-ft-lift Millers Ferry Lock on the Alabama River, operate satisfactorily with a controlled amount of air admitted to the culvert system during the valve opening period. In fact, model tests on Holt Lock indicated that a controlled amount of air would reduce hawser forces on moored tows. This seems reasonable since bubble screens are used to dissipate waves and surges in harbors.

c. Thus, while pockets of air in the culvert system are very

15 Aug 75

undesirable, admission of a controlled amount of air during the valve opening period has proved beneficial at high-lift locks.

2-2. Recent Field Tests of Cavitation Conditions.

a. Tests were made at three locks--Holt on the Warrior River in Alabama, John Day on the Columbia River in Washington-Oregon, and Millers Ferry on the Alabama River in Alabama--to determine conditions under which a controlled amount of air is needed to quiet the pounding noises such as those heard during initial operation of McNary Lock. A summary of certain of the results of these tests is given in Appendix A.

b. In order to evaluate cavitation potential at various projects, a cavitation parameter, K , is used. The form of this parameter used for lock culvert valves is:

$$K = \frac{P + (P_a - P_v)}{V^2/2g}$$

where

P = gage pressure at the top of the vena contracta of the jet emerging from the partially open valve, ft

P_a = atmospheric pressure, ft

P_v = vapor pressure of water, ft

V = velocity in vena contracta of the jet emerging from the partially open valve, fps

g = acceleration due to gravity, ft/sec²

A value of 33.0 ft has been used for the term $P_a - P_v$ in all cases. This probably is correct within 0.5 ft for conditions at existing locks, and available data do not warrant a more refined value. P and V are computed by a program developed at the U. S. Army Engineer Waterways Experiment Station (WES program, Appendix B) and are independent of local pressures on the roof of the culvert, which are influenced by changes in culvert geometry. The value of this parameter at which cavitation is incipient is termed the cavitation index, K_i . Under this procedure, the value of K_i varies with changes in the culvert geometry.

c. Values of the cavitation parameter, K , for the tests described in table A-2 are plotted against percent expansion of the

culvert roof in figure 2-1. Also, a line defining K_i recommended for design purposes is shown in this figure. Since Holt test 2 (only one boom) obviously was near conditions for incipient cavitation while John Day test 3B (several booms) was well within cavitation conditions, there is logic in the manner in which the K_i line is drawn. At Holt and John Day Locks where the culvert roofs slope up downstream from the filling valves there is additional backflow of water into the low pressure zone downstream from the valve. This additional circulation, or water venting as it is sometimes called, results in an increase in pressure on the culvert roof. Measured pressure increases have been plotted as pressure drop (initial lock water surface to minimum gradient) reductions in figure 2-2. If this pressure increase was the only quantity changed then computations with measured pressures should allow establishment of a single K_i value for all roof geometries. This is not supported by available data. It is considered probable that both the velocity and depth at the vena contracta also are modified, but accurate measurements to establish the degree of modification would be difficult.

2-3. Selection of Elevation for Culvert Valves.

a. In design, the lock valves must be placed either at an elevation that will result in the minimum value of K being not less than K_i or at an elevation that will result in negative pressures on the culvert roof and vents must be provided in the negative pressure zone. If an elevation for the culvert is determined such that the minimum value of K equals K_i , then the culvert should be lowered an additional distance equal to one-tenth of the lift as a safety factor. If vents are to be provided, the culvert should be placed at an elevation that will result in about 10 ft of negative pressure on the culvert roof during normal operation. In locks with lifts up to 100 ft, this will result in the pressure gradient dropping below the culvert roof when or before the valve is about 35% open and thus will provide aeration throughout the critical period of the operation cycle. WES program, Appendix B, computes an elevation for the pressure gradient and this gradient elevation can be used directly to determine the pressure on a level roof but must be modified for upsloping roofs as indicated in figure 2-2.

b. A third alternative to the two procedures suggested in the preceding paragraph is to ignore cavitation potential in siting the valves and to use a slow or delayed valve opening schedule such as is recommended for John Day Lock, see paragraph A-11. In an existing lock this may be necessary but it imposes an undue limitation on a new design. A fourth method that has been proposed but is questionable

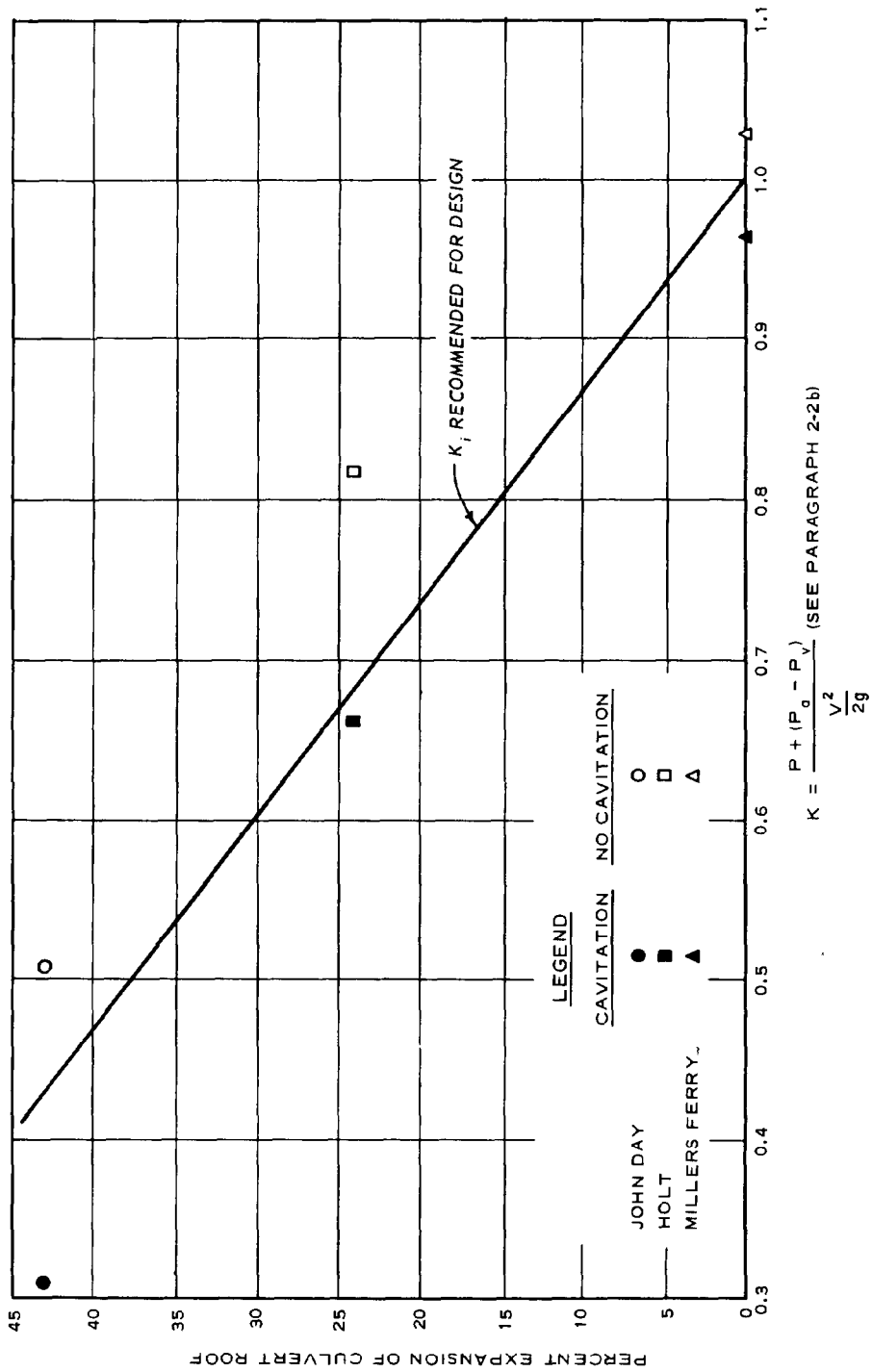

Figure 2-1. Cavitation index

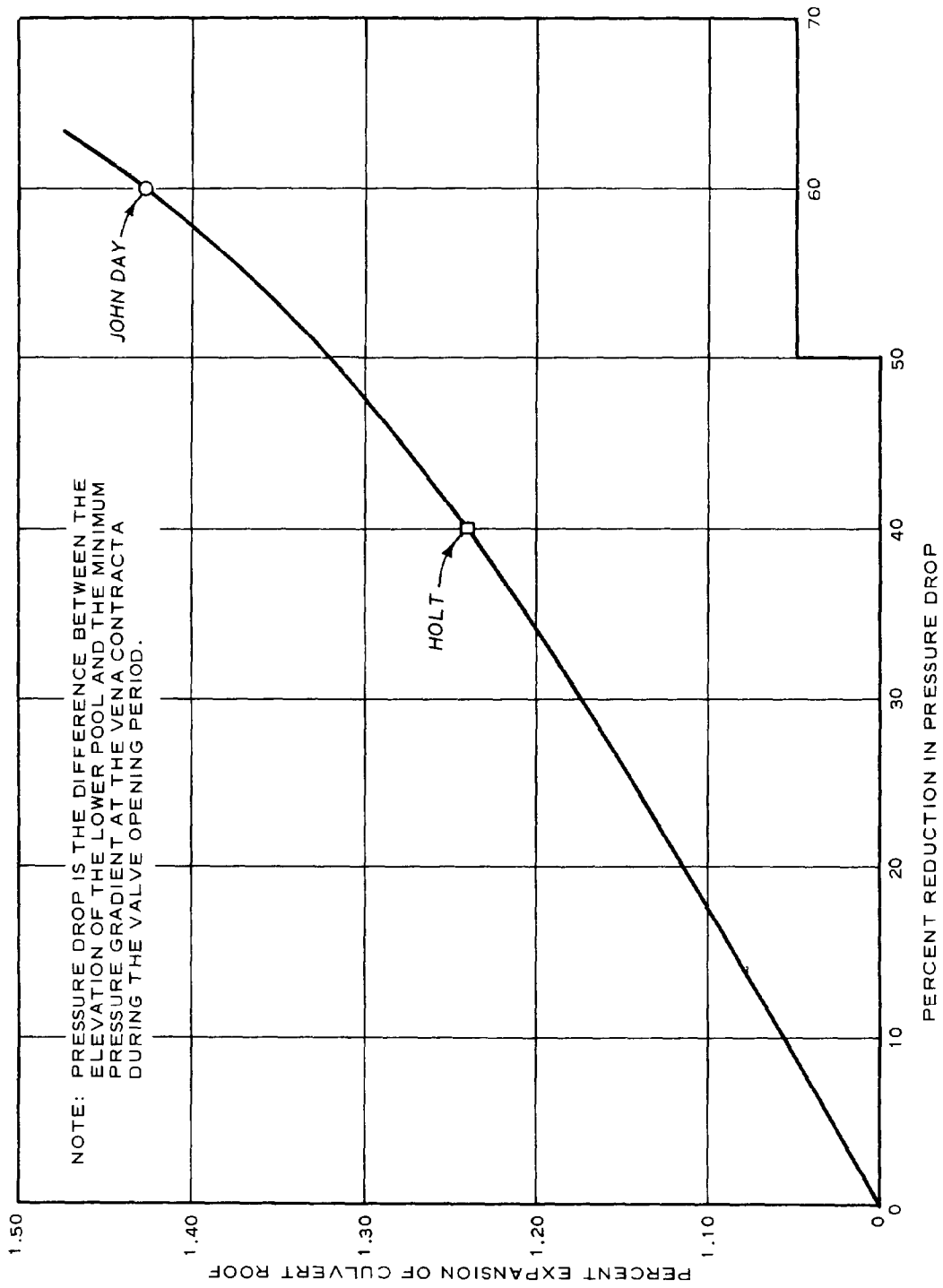

Figure 2-2. Effect of roof expansion on pressure gradient

and not recommended is water-venting by lateral inflow from the lock chamber into the low pressure zone.^{d, e} Such water vents will raise the pressure in the critical zone, an asset; but also the lateral inflow will increase turbulence in this zone, a liability. Systematic field tests would be required to determine whether lateral water vents actually are beneficial or detrimental and to establish design rules for their use.

c. In addition to the requirements listed in paragraph 2-3a, in all cases, the highest point in the culvert system between the filling and emptying valves should be at least 5 ft below the lower pool to assure that air will not seep into the culverts when the lock chamber water surface is at the level of the lower pool.

d. Design examples are given in Appendix C.

2-4. Conclusions and Recommendations Regarding Admission of Air into Culvert System. It is concluded that air pockets in the culvert filling system are hazardous but that air bubbles well entrained in the flow can be beneficial. Thus it is proposed that:

a. All elements of the culvert system between the filling and emptying valves should be at least 5 ft below minimum lower pool.

b. In locks with lifts of 40 ft and less, air should be sealed from the culvert system during filling operations. In low-lift locks, where turbulence levels are low, even small amounts of air admitted during filling could collect in pockets and become dangerous. The lock valves should be placed at an elevation that will result in the minimum value of K being greater than K_i and as a safety factor, the valves should be at an elevation equal to at least one-tenth of the lift less than the elevation required for minimum K to equal K_i . It is indicated in Example 1, Appendix C, that this will not require excessive submergence of the culverts and therefore, in most cases, should not prove costly.

c. In locks with lifts of 60 ft and greater, the valves should be placed at an elevation that will result in about 10 ft of negative pressure on the culvert roof during filling and air vents should be provided in the low pressure zone. An exception could be made in the very unlikely case that foundation conditions are such that it is economically desirable to place the valves very deep with respect to lower pool. Consideration of Example 2, Appendix C, provides insight into the submergence that would be necessary to prevent cavitation.

d. In locks with lifts of 40 to 60 ft, decision as to whether

cavitation will be prevented by submergence or admission of air should be based on economic considerations for the particular project.

2-5. Design of Air Vents.

a. All filling-valve air vents should be provided with means for controlling the amount of air entering the culvert system. Bulkhead slots, valve wells, or other such openings into the culvert should never be allowed to double as air vents for the filling valves.

b. Air vents for emptying valves should be controlled, the same as for filling valves, if flow is discharged into the lower approach to the lock. However, if flow is discharged outside of the lock approach, excessive air is not likely to be harmful and bulkhead slots can be used to double as air vents.

c. A satisfactory vent system for a valve would consist of two independent 12-in.-diam pipes entering flush with the culvert roof between the quarter and third points across the culvert. A vent slot extending across the roof of the culvert as provided in flood control conduits is not required. The vents should enter the culvert roof within the low pressure zone which extends from the valve to the vena contracta of the jet passing under the valve. Location of the vena contracta varies with culvert height and valve opening but vents have performed satisfactorily when placed no more than a distance of one-half of the valve height downstream from the valve well. The vent pipes should be brought through an accessible location, such as the platform that supports the valve operating machinery, and then to openings on the outside face of the lock wall at an elevation above the maximum pool at which the lock will be operated. Openings on the top or inside face of the lock wall are nuisances to personnel on the wall or in the lock chamber. A valve should be inserted in each vent at the accessible location. At the time the lock is put in operation, hydraulic design personnel should assist in determining vent valve settings that will preclude cavitation without an excessive amount of air and thus added turbulence in the lock chamber or lower approach. This should not be difficult as past experience has shown that satisfactory performance can be obtained within a range of settings. The vent valves should be locked in the desired position to prevent accidental changing of the setting.

CHAPTER 3. HOIST LOADS

3-1. Hoist Loads due to Flowing Water.

a. Tainter Valves. Three structurally different types of reverse tainter valves (horizontally framed, double skin plate, and vertically framed) have been used in recent designs of lock filling and emptying systems. The horizontally framed valve is desirable structurally but the double skin plate and vertically framed valves are less susceptible to critical hydraulic loads and load variations during the opening cycle.

b. Interpretation of Data. Hoist loads presented herein are the summation of forces on the valve members due to flowing water considered as a single force acting radially at the valve skin plate. Downpull loads act to rotate the valve to the closed position and uplift loads act to rotate the valve to the open position. Basic data were obtained with the valve at fixed positions and under steady-flow conditions. For each valve position, hoist-load data were obtained for a range of velocities under the valve (inflow or outflow divided by total valve opening). For the plots herein, figures 3-3 to 3-6, the velocity under the valve at each valve position was computed (see Appendix B) for different lifts in a specific lock. Table 3-1 gives the relation of velocity under the valve to lift used in plotting the data in figures 3-3 to 3-6.

Table 3-1. Velocity Under Valve, fps

Valve Open Percent	Lift, ft			
	20	40	60	100
0	0.0	0.0	0.0	0.0
10	28.5	41.0	50.0	65.0
20	27.5	39.0	49.0	63.5
30	26.0	37.0	45.5	59.5
40	26.0	37.5	46.5	60.5
50	26.5	39.0	48.5	64.0
60	27.0	40.5	50.0	66.5
70	27.5	40.5	50.5	67.0
80	26.5	39.5	49.0	65.0
90	25.0	37.0	46.5	61.0
100	23.0	34.5	43.0	57.0

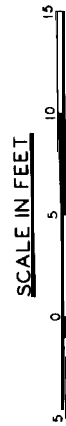
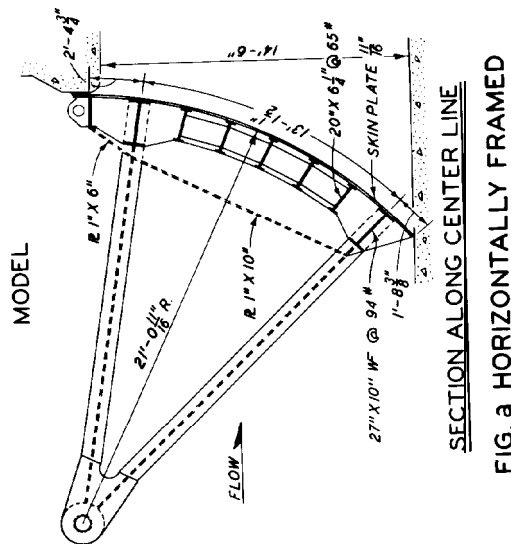
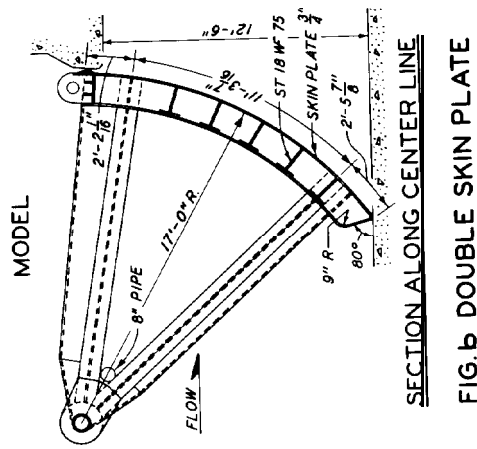
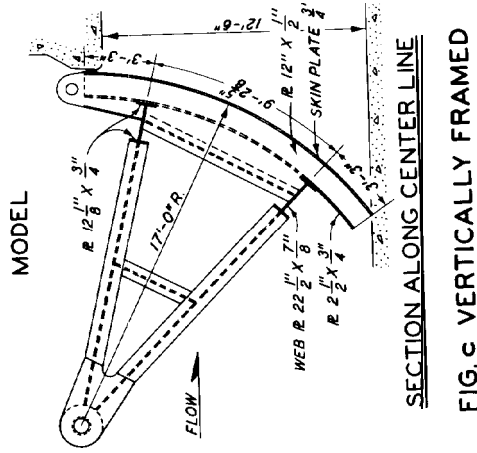
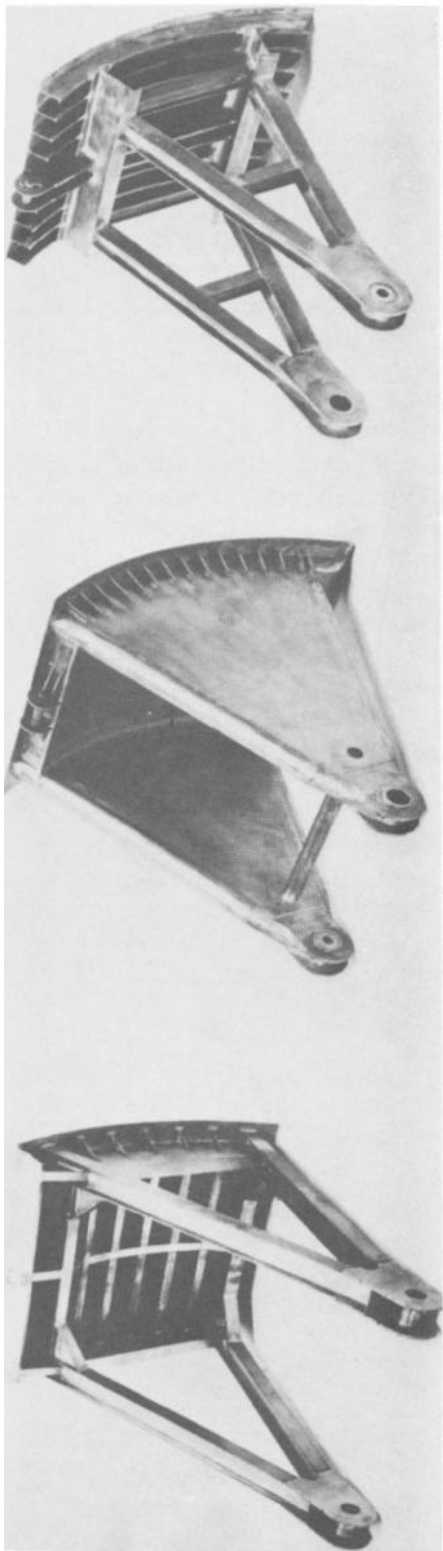

tainter type valves

Figure 3-1

c. Horizontally Framed Valve.

(1) As the name implies, the skin plate is attached directly to a series of horizontal beams and the loads are transmitted to the trunnion arms through vertical frames or girders near the sides of the valve (see fig. 3-1a).

(2) Horizontally framed valves were used almost exclusively in earlier low-lift locks and no inadequacies were indicated until locks in the medium- and high-lift category were required. Serious operational problems with the horizontally framed valve resulting from forces due to flowing water first were encountered in New Lock No. 19, Mississippi River.^f

(3) During trial operations at New Lock No. 19 it was found that when a valve was at greater than two-thirds angular opening, flowing water caused pulsating loads which were transmitted through the strut and strut arm, resulting in reversal of load on the operating machinery and a consequent severe clattering in the gear train. The pulsations appeared to increase in magnitude with increased valve opening. The resultant loading conditions were of such severity that remedial action was necessary prior to normal operation of the project.

(4) At New Lock No. 19, the lift is 38.2 ft and flow through the culverts is regulated by 14.5- by 14.5-ft reverse tainter valves. The valves are actuated by electric motors through strut-connected mechanical gear systems. Each valve weighs 28,350 lb, with the strut and strut arm adding weights of 3,500 and 3,100 lb, respectively. With a valve submerged in still water, the load on the hoist varied during an opening cycle from about 21 kips (1.45 kips per foot of valve width) near the closed position to about 31 kips (2.14 kips per foot of valve width) near the open position.

(5) Model tests revealed that under normal operating conditions flowing water caused an average load on the hoist in a downpull direction from a gate opening of 0 to about 75% and in an uplift direction from 75 to 100%. Flow approaching the partially open valve divided at the upstream face of the valve with part of the flow going under the valve and part into circulation in the valve well. When this division was above the lower girder, downpull forces prevailed and below the lower girder, uplift forces occurred. Flow patterns in the valve well during downpull and uplift conditions are shown in figure 3-2. Also, it was revealed that random variations in hoist load increased as the valve opening increased. With the valve near the open position, loads

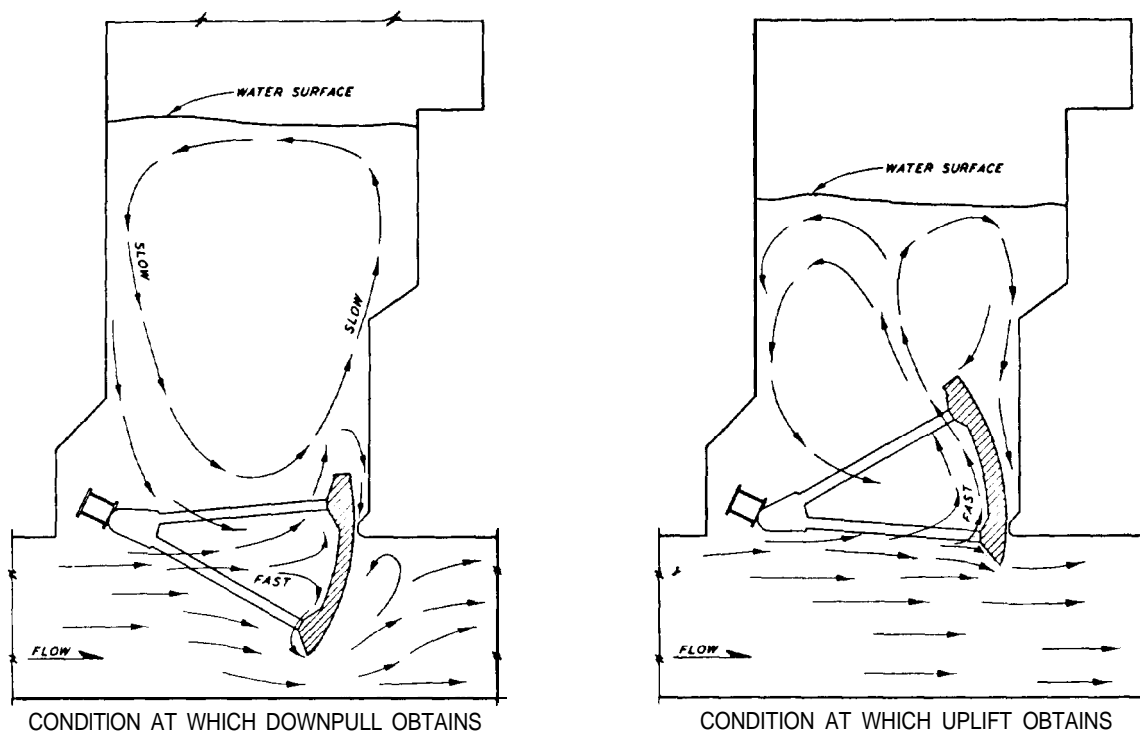
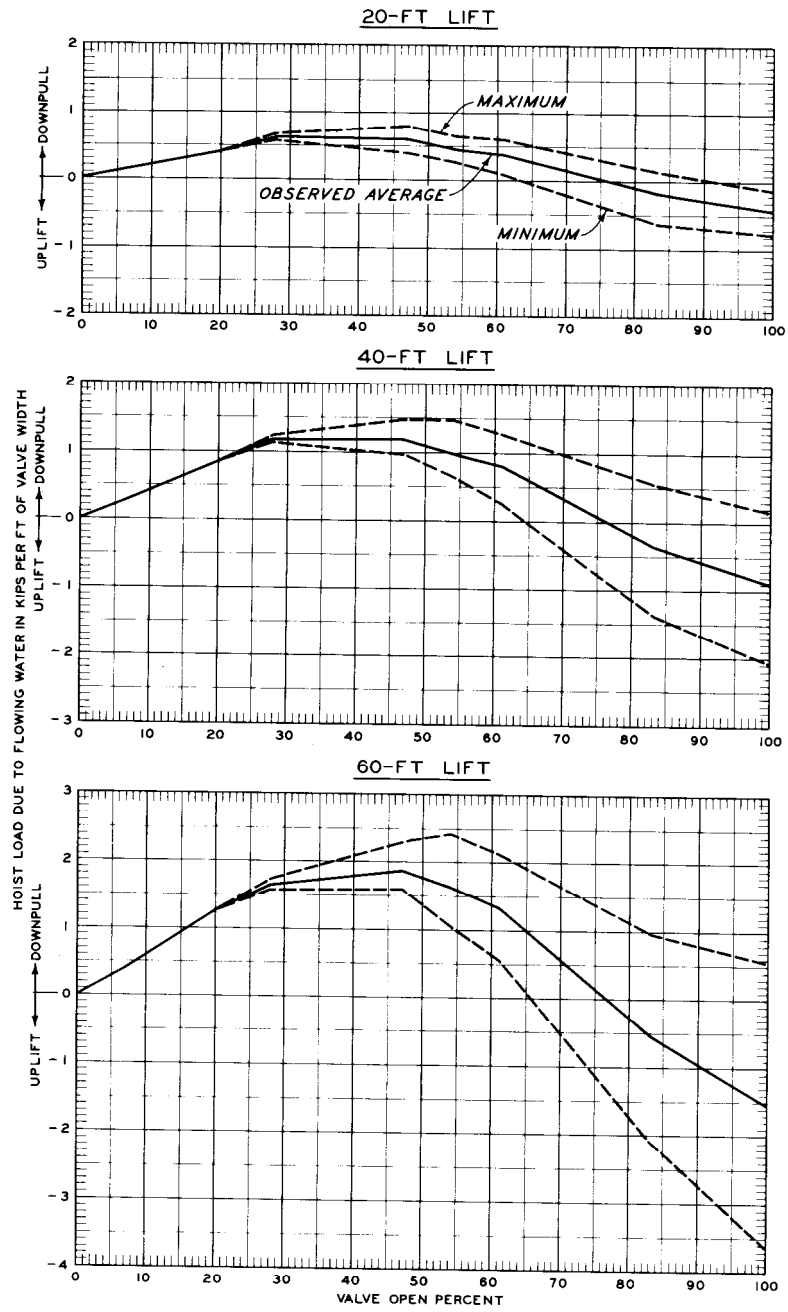

Figure 3-2. Currents in valve recess

on the hoist due to flowing water varied from 12 kips (0.83 kips per foot of valve width) downpull to 48 kips (3.31 kips per foot of valve width) uplift. Thus, with the submerged valve exerting a downpull load of only 31 kips on the valve hoist, it is obvious why severe clattering resulted in the gear train.

(6) Hoist loads due to flowing water obtained in a 1:12-scale model of the valve shown in figure 3-1a at lifts of 20, 40, and 60 ft are plotted in figure 3-3. For planning purposes, these data are considered generally applicable and the prediction of total loads for similar valves based on the width of the valve is justified by the fact that tests have revealed that modifications to valve members above the lower girder have a very small effect on hoist loads. Thus, the height of the valve has a negligible effect on hoist loads except as it modifies the velocity of approach and this is accounted for by plotting valve opening as a percentage of total opening rather than as a specific dimension.

(7) Modifications to the lower girder and the portion of the valve below the girder can have a material effect on valve loads.^{f, g} For



(SEE PARAGRAPH 3-1b)

Figure 3-3. Hoist loads, horizontally framed valve

15 Aug 75

instance, installation of a cover plate from the valve lip to the flange of the lower girder resulted in a 30% increase in peak downpull but a 35% decrease in both peak uplift and load variation.

d. Double Skin-Plate Valve.

(1) With the objective of presenting a smooth upstream surface to flow, instead of the projecting edges of the horizontal beams, the transverse beams are covered with a smooth, curved skin plate which results in a streamlining effect (see fig. 3-1b). The inside plate adds rigidity to the leaf and can be utilized in the stress analysis. It is customary to use welded construction, making the tank watertight. Thus, the valve can be operated with the tank filled with air, provided the valve has sufficient weight to counteract its buoyancy as well as the dynamic hydraulic uplift forces. In most instances, however, greater stability is needed and the tank is filled with water and a rust-inhibiting fluid.

(2) General design values of hoist loads due to flowing water obtained in a 1:15-scale model of the valve shown in figure 3-1b at lifts of 20, 40, 60, and 100 ft are plotted in figure 3-4. Results of other tests on valves of this type are given in references a, d, i, j, and k.

e. Vertically Framed Valve.

(1) In valves of this type the skin plate is attached to a series of curved T-beam ribs along parallel vertical planes (see fig. 3-1c). The water loads are transmitted to the trunnion arms through horizontal girders welded to the outer flanges of the ribs. Thus, open spaces where water can circulate freely are provided between the ribs, and between the skin plate and the horizontal girders.

(2) General design values of hoist loads due to flowing water obtained in a 1:15-scale model of the valve shown in figure 3-1c at lifts of 20, 40, 60, and 100 ft are plotted in figure 3-5. The flanges on the T-beam ribs that transmit loads from the skin plate to the horizontal girders must be narrow. Flanges 2.5 in. wide were suitable in the example valve, but flanges 12 in. wide inhibited the desired circulation and were very detrimental to loading characteristics. Results of an additional test on a valve of this type are given in reference g.

f. General Comments.

(1) Average loads and maximum load variations for the three valves shown in figure 3-1 at a 60-ft lift are plotted in figure 3-6 to show the relative load characteristics of each valve.

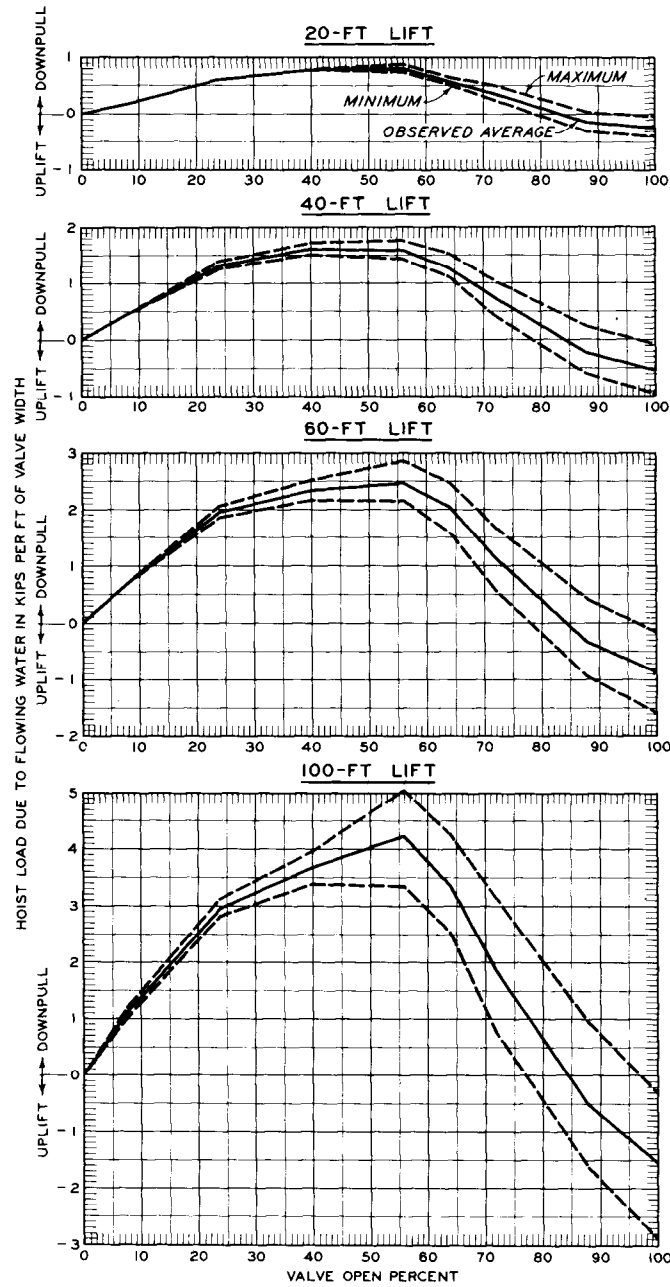

(SEE PARAGRAPH 3-1b)

Figure 3-4. Hoist loads, double skin-plate valve

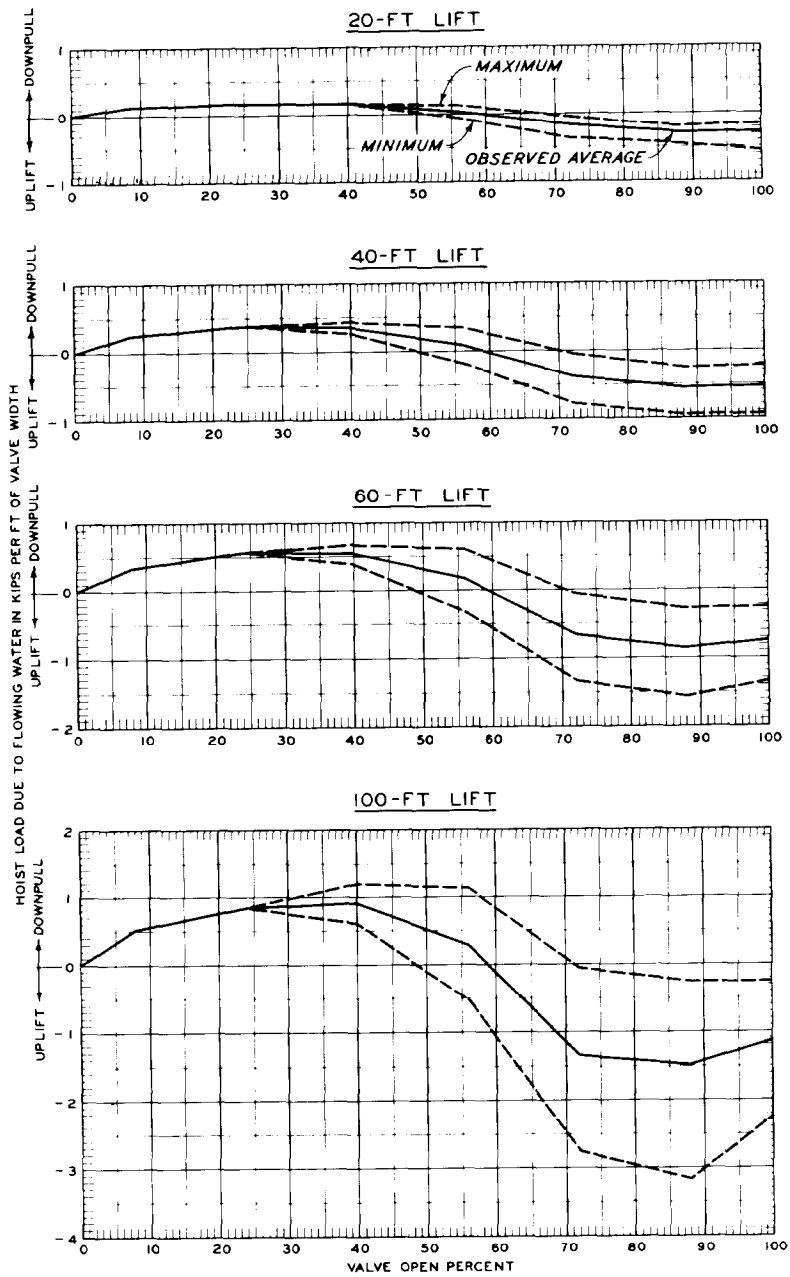

(SEE PARAGRAPH 3-1b)

Figure 3-5. Hoist loads, vertically framed valve

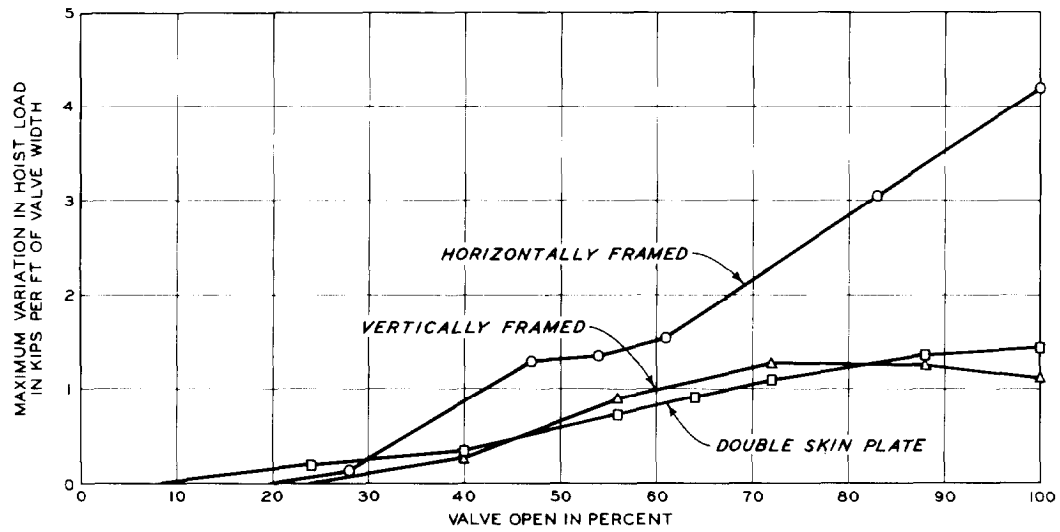
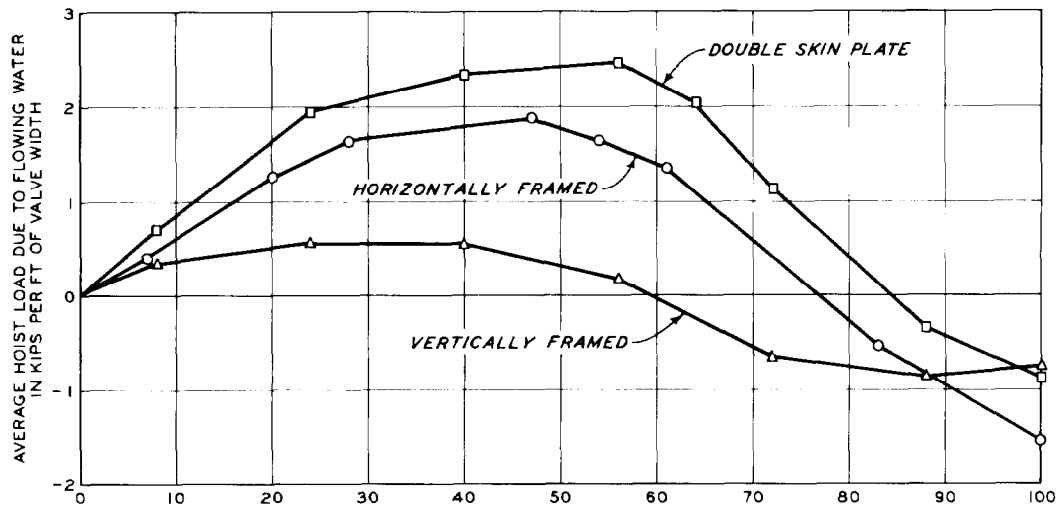

(SEE PARAGRAPH 3-1b)

Figure 3-6. Hoist loads, 60-ft lift

(2) For all three types of valves the two features that most affect loads on the valve hoist due to flowing water are the depth of the lower girder and the extension of the lower lip of the skin plate below the lower girder. A decrease in the depth of the lower girder results in a decrease in peak downpull and load variations and, also, a decrease in the range of valve positions at which downpull occurs and an increase in the range of positions at which uplift occurs. Data are not conclusive as to whether peak uplift is decreased. An increase in the extension of the lower lip of the valve below the lower girder decreases peak downpull and the range of valve positions at which downpull occurs but increases peak uplift and the range of valve positions at which uplift occurs. Load variations remain essentially unchanged.

(3) The effect of load reversals on the valve hoist was demonstrated dramatically at New Lock No. 19 by the severe clattering in the mechanical gear system. When operation is directly from a hydraulic piston, load reversals are not readily noticeable. However, these load reversals still are very undesirable as they are likely to result in excessive wear in the strut connections and could cause other structural damage.

(4) It should be apparent to the designer that consideration of a horizontally framed valve should be limited to locks with lifts of no more than about 30 ft. When designed for equal lifts, the double skin-plate valve usually will be heavier and, particularly if the tank is filled with a rust inhibitor, will require greater hoist capacity than will the vertically framed valve. However, some designers consider a heavy valve to be more stable and thus worth the cost of the additional hoist capacity. Certainly the double skin-plate valve can be used successfully at all lifts. The vertically framed valve probably has economic advantages over the double skin-plate valve and is being used with no problems at the 63.6-ft lift Holt Lock. If this valve is considered for a lock with a very high lift, excess weight may be required to prevent load reversals on the valve hoist.

3-2. Total Hoist Loads. In determination of total hoist loads, the designer must combine the loads due to flowing water (discussed in paragraph 3-1) with loads resulting from: (a) weight of the submerged valve, (b) weight of the operating stem, (c) friction at the side seals and in the trunnion, and (d) head differentials across the top seal (paragraphs 4-4 and 4-4a).

3-3. Peak Head Across Valve.

- a. Near the beginning of a filling or emptying operation if a

15 Aug 75

failure of the hoisting mechanism should allow a valve to slam shut, a head across the valve considerably larger than the difference between upper and lower pool would result. Time-history of pressures on each side of the valve can be developed from available formulas concerned with surges and water hammer. Pressure oscillations on each side of the valve will occur with decreasing amplitudes through several cycles. However, the periods of these oscillations are likely to be different on the two sides of the valve; and although individual peaks (positive and negative) on each side of the valve probably will occur during the first cycle, it is possible that the maximum head across the valve will occur later and be less than the difference between the first cycle peaks. Also, there are likely to be reversals in the head across the valve.

b. In a reverse tainter valve installation, the valve well would serve as a surge chamber and thereby delay and reduce the buildup of pressure on the high-head side of the valve. Although the surge in the valve well would spill out at the top of the lock wall the pressure on the valve would result from forces causing flow up the well and could be considerably greater than the difference between the top of the wall and the valve. If the valve is not vented, the pressure on the low-head side of the valve could drop quite rapidly to about -33 ft (one atmosphere negative); with a vented valve, the pressure would drop to essentially atmospheric.

c. Sudden closure of a valve due to breakage of the hoisting mechanism is very unlikely to occur and usually is not considered a design condition. On the other hand, operation that would produce surges is most probable. For many reasons the operator may reverse the valves during or immediately after the opening cycle. A series of tests was conducted in the Cannelton Lock model¹ during which the 18-ft-high by 16-ft-wide filling valves were opened at a rate to reach fully open in 2 min. Immediately upon reaching 1/2, 3/4, and then fully open, the valves were reversed and closed at the same rate. The surges generated produced a peak head differential across the valve of about 1.5 times the initial lift.

d. The conditions of peak head across the valve to be used in the structural design should depend on the local situation and judgment on the part of the designers. Certainly all designs must provide for the head created by the abnormal operation described in paragraph 3-3c. The hydraulic designer should describe the possible loadings that could result from operational and accidental closure of the valves during a filling or emptying operation.

CHAPTER 4. VALVE SEALS

4-1. General. Valve seals are the responsibility, primarily, of mechanical design but the hydraulic designer should be aware of cavitation, vibration, and hoist load problems that can result from poor seals. Leaks around valves in high-lift locks can result in cavitation and possible damage to the culvert or the valve. The seals given as examples in this manual have proved satisfactory; however, other arrangements of seals have also been used successfully. It has been found that inadequate anchorage is one of the major causes of problems with embedded items. The blockouts and anchorage systems shown on the examples of seals given herein are required for proper installation.

4-2. Bottom Seals. Satisfactory sealing across the bottom of a tainter valve can be accomplished by pressure contact of the lip of the valve on a metal sleeper embedded in the culvert floor (see fig. 4-1). The bottom edge of the skin plate should be ground in the field to provide a smooth and uniform contact with the sill plate. Flexible (rubber) bottom seals can be a source of serious vibrations; and since it has been demonstrated that with reasonable care good metal-to-metal contact can be obtained for the full length of the sill, use of flexible seals is not advocated. However, a compression-type rubber bottom seal has been used successfully on high-lift locks by the Walla Walla District.

4-3. Side Seals. Rubber J-type seals are recommended for the sides of the valve, figure 4-1. These seals should bear against and slide along curved stainless steel plates embedded flush with the culvert walls. Also, these plates should extend into the valve well for the full height of the opened valve in order to provide lateral support for the valve in the open position. In several installations where lateral support was not provided for the fully open valve, the jostling action of the highly turbulent flow circulating in the valve well resulted in loosening of trunnion anchorages and other damage. The side plates should be free of irregularities that might cause the rubber seal to wear or lose contact. It is very important that the rubber seals be adjusted to maintain a relatively uniform contact with the seal plates. Loss of contact, in addition to allowing leakage, can result in seal flutter which will cause serious vibrations throughout the valve.

4-4. Top Seals. The seal at the top of the valve is likely to present more problems than those at the sides and bottom. The top seal must mate smoothly with the top seal plate and, at the same time, allow the bottom edge of the valve to rest with sufficient pressure on the sill to seal the valve at the bottom. A prolonged rubbing contact and slow breakaway are very undesirable as they are conducive to vibration.

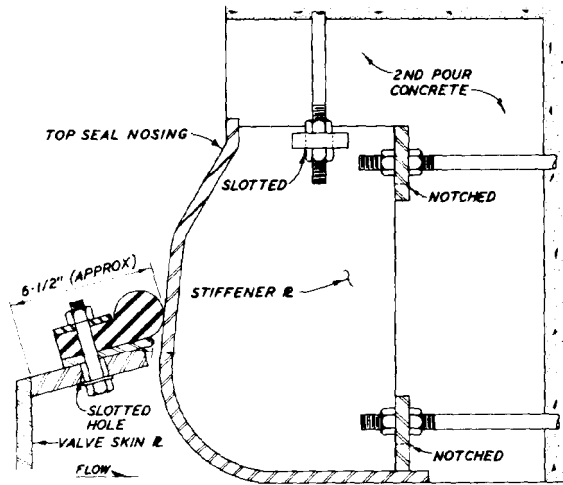

REVERSE TAINTER VALVE TOP SEAL
 LOW HEAD PROJECTS

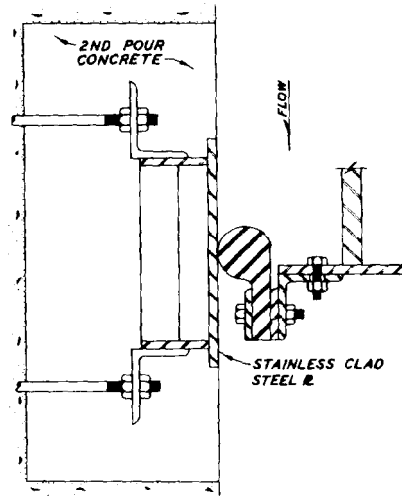

TAINTER VALVE SIDE SEALS

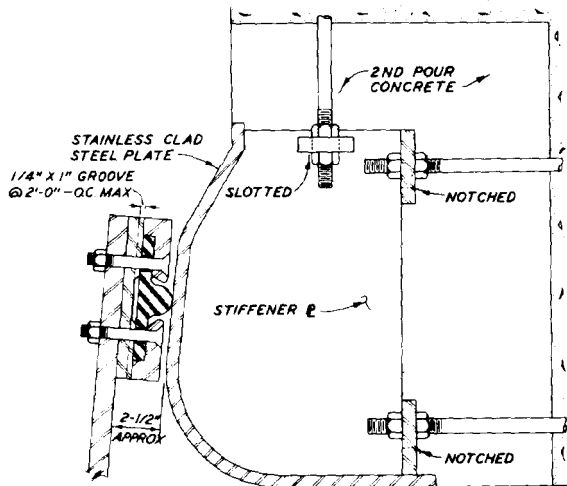

NORMAL AND REVERSE TAINTER VALVE
 TOP SEAL HIGH AND LOW HEAD PROJECTS

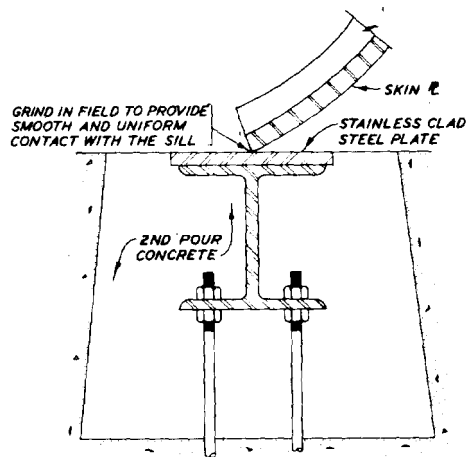

TAINTER VALVE BOTTOM SEAL

- NOTES: 1. PROVIDE 0.060° ABRASION RESISTANT FLUOROCARBON FILM ON RUBBER SEALS
 2. SEAL RETAINER BOLTS SHOULD BE LOCKED TO PREVENT LOOSENING DUE TO VIBRATION

Figure 4-1. Valve seals

Also, the portion of the top seal including the seal bracket that extends beyond the skin plate is exposed to an unbalanced head equal to the lift. This head decreases as the seal moves away from the top seal plate and becomes zero when the distance between the top seal and any part of the gate well face exceeds the distance between the skin plate and the seal plate. In a reverse tainter valve at the beginning of the opening cycle, the hoist must overcome this unbalanced head at the same time it is "breaking" the seals and this may result in the peak load on the hoist. Obviously, it is desirable to maintain the seal projection on the valve as short as practicable.

a. Two designs for the top seal are shown in figure 4-1. One design is suitable only for reverse tainter valves in locks with relatively low lifts (about 40 ft or less). In this design, the seal bracket projects about 6 in. (horizontally) beyond the skin plate. The unbalanced load in pounds per foot of valve width with the valve closed is equal to 31.25 times the lift in feet. The other design is suitable for all lifts with the valve in either the reverse or normal position. The unbalanced load (downpull for reverse tainter valve, uplift for normal) on this seal in pounds per foot of valve width is only about 13 times the lift in feet. A J-type seal also can be used in high-lift projects, but the clearance between the skin plate and seal nose should not exceed about 2-1/2 in. and the seal bulb should be partially constrained to prevent excessive flutter as the seal is broken.

b. It is difficult to prevent leaks at the junction of the side and top seals. For projects with lifts up to about 40 ft, a molded corner that in effect makes a continuous seal is desirable. However, molded corners tend to transmit movement of the side seals to the top seals and have caused working and eventual failure of the top seals. An arrangement that allows independent movement of side and top seals is suggested at projects with lifts greater than about 40 ft.

CHAPTER 5. RECESSES FOR UNWATERING BULKHEADS

5-1. General. To allow for service and repair to a valve without taking the lock out of operation, bulkhead recesses are provided on the high- and low-head sides of each of the four valves. Each recess consists of slots in the sides of the culvert, an opening in the culvert roof, and a shaft extending to the top of the lock wall. Although it is unlikely that more than one valve will be under repair at a given time, two sets of bulkheads normally are provided at each project to block upper and lower pools from the culvert system for unwatering of the lock. For storage, the bulkheads usually are held near the top of the shafts by dogging devices.

5-2. Bulkhead Recesses. Open-well bulkhead recesses on the high-head sides of the four valves have caused no problems during filling and emptying of the lock. However, there is one known case of a surge in the bulkhead recess created by operation, as discussed in paragraph 3-3c, lifting the bulkhead off of the dogging devices and then allowing it to slam down with sufficient force to break the dogging devices and drop into the culvert. The lifting force was due primarily to the stored bulkhead restricting flow up the shaft. It is suggested that the shaft be enlarged (see fig. 1-1) at the position of the stored bulkhead.

5-3. Location of Bulkhead Recesses. During the valve opening period, a zone of low and unstable pressures extends about 6-1/2 times the culvert height downstream from the valve. Usually, other considerations make it desirable to locate the bulkhead recess for the low-head side of the valve within this zone. Thus, an open well for the bulkhead recess on the low-head side of the valve would be a potential source for excess air entering the culvert system. Except for recesses on the low-head side of emptying valves discharging outside of the lower approach to the lock (see paragraphs 2-5a and b), the bulkhead recess on the low-head side of each valve should be sealed. Further, it is desirable that this seal be placed just above the level of the lower pool. If placed near the top of the lock wall, oscillations develop in the column of water in the bulkhead shaft and at some valve opening these oscillations interplay with and amplify the oscillations in the recess, causing unstable loads on the valve hoist.

APPENDIX A

CAVITATION AT LOCK CULVERT VALVES

A-1. During 1948, a 1:20-scale model of the 11-ft-wide by 12-ft-high valve proposed for the 92-ft lift McNary Lock on the Columbia River between Washington and Oregon was tested in a vacuum tank at the U. S. Army Engineer Waterways Experiment Station.^b Cavitation induced in the vacuum tank occurred in the cores of large vortexes that were shed randomly from the valve lip. Test results indicated that these large cavities would occur in the prototype unless the invert of the culvert at the valve section was placed at least 163 ft below the upper pool. The prototype was constructed with the invert of the culvert at the filling valves only 112 ft below the upper pool. Six 12-in.-diam air vents, two in the culvert roof and two in the upper portion of each sidewall, were installed immediately downstream of each valve. During initial operation of the lock, the air vents at the filling valves were capped. Pounding noises, resembling thunder or cannon shots, seemed to come from the bulkhead slots on the downstream sides of the filling valves when the valves were partially open. Certainly the collapse of large cavities, such as were indicated by the model, would be expected to result in pounding noises rather than the rattling gravel-type sounds that are heard in cavitating pumps, turbines, etc. With one 12-in.-diam vent open in the roof of the culvert downstream from each filling valve, the pounding noises are eliminated. It is concluded that sufficient air is drawn into this vent to cushion the collapse of the large cavities, eliminate shock pressures, and thus eliminate the pounding noises.

A-2. In the 113-ft lift John Day Lock on the Columbia River between Washington and Oregon, the culvert valves are 12 ft wide by 14 ft high. The culvert roof slopes up at the rate of 1V on 10H, beginning 19 ft from the downstream face of the filling valve recess to a height of 20 ft. This, together with the depth at which the culvert is placed, results in positive pressure on the roof of the culvert throughout the filling cycle. Although vents are installed downstream from the valve, they do not draw air during a normal 4-min valve time filling operation; however, severe pounding noises emit from the culvert.

A-3. In order to develop a method for improved operation of John Day Lock and to obtain data for design of future locks, cavitation tests were conducted at Holt, John Day, and Millers Ferry Locks.

A-4. General dimensions and elevations for the three locks at which tests were made are listed below:

15 Aug 75

Table A-1

Item	Holt	John Day	Millers Ferry
Location	Warrior River, Alabama	Columbia River, Washington-Oregon	Alabama River, Alabama
Chamber dimensions, ft	110 x 670	86 x 685.4	84 x 655
Type of filling system	Interlaced lateral	Split lateral	Bottom Longitudinal
Normal upper pool el	186.5	268	80
Min lower pool el	122.9	155	32
Max lift, ft	63.6	113	48
Size of reverse tainter valves, ft (width x height)	12.5 x 12.5	12 x 14	10 x 10
Culvert roof at filling valves, el	115	128	26
Size of culverts downstream from filling valves, ft (width x height)	12.5 x 15.5†	12 x 20††	10 x 10

† The culvert roof slopes up at the rate of 1V on 8H beginning at the downstream face of valve recess.
 †† The culvert roof slopes up at the rate of 1V on 10H beginning 19 ft from the downstream face of the valve recess.

A-5. During normal operation at Holt and Millers Ferry Locks, the filling valves are opened in 4 and 2 min, respectively; and a controlled amount of air is admitted to the system through vents downstream from the filling valves. Performance of the filling system at each of these locks is very satisfactory. At John Day Lock, the valves are opened in about 15 min, as pounding noises occur when the valves are opened at a faster rate.

A-6. Cavitation observations were made at all three locks with the air vents at the filling valves sealed; thus, no air was admitted to the culvert system during filling operations. Prior to starting each test, the filling valves were held at a small opening until the lock chamber water surface was raised to a predetermined level; the valves were closed and the system was allowed to stabilize. A normal filling operation then was performed. This procedure was repeated with various initial water-surface elevations in the lock chamber.

A-7. In the valve wells at Holt and Millers Ferry Locks, measurements were made of sound levels and recordings were made of sounds. Also, total valve time, constancy of valve movement, and initial water-surface elevations in the upper pool and lock chamber were noted. Formal reports were not prepared on these observations. At John Day Lock, 13 simultaneous measurements were made and recorded, both on magnetic tape and a light-beam oscillograph. Data taken included: valve position, lock water-surface elevation, pressures in the culvert at six points, sound at top of valve well, and air flow in vents. Results of these tests are described in reference c in paragraph 1-3.

15 Aug 75

A-8. Two phases of the test results are of primary interest in this manual. First, pressure measurements in the culverts at John Day Lock were made to determine the magnitude of pressures concurrent with the loud booms. It was found that the booms were accompanied by rapid pressure fluctuations from one atmosphere negative to about 100 psi positive. While these pressure conditions were most severe a short distance downstream from the filling valve, they carried throughout the system and were reduced only about 50% in the culvert immediately upstream from the emptying valve. Certainly, pressure conditions such as these cannot be tolerated for extended periods of operation without expectancy of a structural failure somewhere in the system. In a special test, bulkheads in the slot upstream from an emptying valve were unseated by the negative phase of the pressure surge. Thus, in a lock where cavitation might occur at the filling valves, a culvert should never be used for filling when the emptying valve for that culvert is bulkheaded off for maintenance or repairs. The second item of primary interest is the determination of conditions for incipient cavitation at each of the projects.

A-9. Data from the two tests that bracketed incipient cavitation at each project are tabulated below:

Table A-2

Item	Project					
	Holt		John Day		Millers	Ferry
	Test 2	Test 6	Test 2A	Test 3B	Test 5	Test 6
<u>Initial Conditions (Observed)</u>						
Upper pool el	186.3	186.3	262.3	262.8	80.3	80.3
Lock water surface el	144.0	140.5	180.0	169.5	46.0	45.0
Lift, ft	42.3	45.8	82.3	93.3	34.3	35.3
Culvert roof at valve, el	115	115	128	128	26	26
Submergence culvert roof at valve., ft	29	25.5	52	41.5	20	19
<u>Valve Time, min (Observed)</u>	3	3	4	4	2	2
<u>Conditions at K , min (Computed)</u>						
Valve open, %	61.5	61.5	57.1	57.1	59.5	59.5
P	15.9	10.1	24.3	7.1	13.2	11.7
V	62.0	64.8	85.6	91.7	53.8	54.7
K (see para 2-2b)	0.819	0.661	0.504	0.307	1.029	0.964
<u>Comments</u>	Quiet	One distinct boom	Quiet	Several loud booms	Quiet	Coughing noises

15 Aug 75

A-10. Cavitation at Holt and John Day Locks was indicated by very similar pounding noises that resembled thunder or cannon shots. When test conditions were such that cavitation was incipient, the booms occurred only when the valve was near 60% open. As conditions for cavitation were made more severe, booms were observed progressively at valve positions both less and more than 60% open; but there was no noticeable change in the intensity of the sound of the booms. At Millers Ferry Lock, cavitation was indicated only by coughing noises; and observers questioned whether these noises were accompanied by serious pressure fluctuations. With the level rather than the upsloping roof of the culvert downstream from the Millers Ferry valve, the pressure rise in the culvert certainly is more gradual than at Holt and John Day Locks. Also, during the tests, the most severe conditions for cavitation which were allowable (lift 42.5 ft with lower pool 11.5 ft above roof of culverts at filling valves) resulted in velocities less than those at which cavitation was observed at the other locks. Thus, it is probable that the collapse of the cavities was not sudden enough to produce loud sharp booms. However, at higher velocities loud sharp booms were produced in the McNary conduit which also has a level roof.

A-11. Engineers of the Mobile District have concluded that optimum operating conditions result with 6-in. orifice plates at Holt and 3-in. orifice plates at Millers Ferry in the two 12-in.-diam vents at each filling valve. It has been recommended that the valves at John Day Lock be opened to a 30% opening as rapidly as is feasible, maintained at this opening for 5 min, and then opened as rapidly as feasible to the fully open position. This requires a total time for opening the valves of about 6-3/4 min. During the tests it was verified that the above procedure eliminates the loud noises attributed to cavitation and results in a filling time of about 13 min rather than 16 min when the valves are opened at a constant speed in 15 min.

APPENDIX B

LOCK FILLING PROGRAM

MEMORANDUM FOR RECORD

8 March 1974

SUBJECT: Engineering Summary of Lock-Filling Program "FLOCK" (Millers Ferry Prototype Test Conditions)

OVERVIEW

1. Introduction. This FORTRAN program has been used primarily to simulate existing model and prototype test data. The input format is designed for expedient time-share operation and permits convenient changes in the values of flow coefficients, in the basic lock geometry, and in selecting which computed values are to be printed or plotted. The four primary deficiencies of the program in regards to being a comprehensive lock design program are as follows:

a. Type of lock operation. The program is for filling only; no allowance is made for emptying operations.

b. Valve schedules. Single valving and synchronous valving are included; nonsynchronous, stepped, or nonsimilar (land wall different than river wall) valving is not programmed.

c. Culvert geometry. The two culverts are identical; that is, the length, width, and height of the land-wall culvert is the same as that of the river-wall culvert; and the intake, conduit, and manifold loss coefficients of the two culverts are equal. These conditions are generally no drawback in analyzing a symmetrical filling system (Dardanelle Lock, Arkansas, for example); for contradictions to these conditions (a split lateral system, for example), average values are used as input data.

d. Calibration. The model should be calibrated for single-valve and synchronous-valve operation in order to accurately evaluate the flow coefficients. This may be done by means of (1) prototype tests, (2) model tests, or (3) using values pertinent to similar systems that have either model or prototype data available. A good estimate of the total loss coefficient may be calculated if the traditional lock-filling coefficient is known.

WESHF

8 March 1974

SUBJECT: Engineering Summary of Lock-Filling Program "FLOCK" (Millers Ferry Prototype Test Conditions)

2. The first three deficiencies are programmable; the fourth one will be resolved as more model and prototype data for different types of filling systems are inspected. Time and need permitting, a computer program will be constructed that will overcome the programmable deficiencies. Meanwhile the program "FLOCK" has accomplished the following:

a. The general mathematical formulation (an unsteady-flow problem is simulated by a succession of steady-flow situations; each steady-flow solution is modified to include an approximate inertial-correction term) has proven to be a reliable representation of the performance of the prototype and model locks studied.

b. The stepped predictor-corrector scheme used in the calculations has been shown to provide a sufficiently accurate solution.

c. A means of determining the pressures immediately below the valves (based on experimentally determined contraction coefficients) has been established.

d. The effects that the valve opening time, the loss coefficients, the lock and culvert geometry, and the head loss through the culverts have on filling time, overtravel, pressure below the valves, lock chamber rate-of-rise, and other dependent phenomena have been observed in some detail.

3. Since "FLOCK" is relatively small and convenient (compared with a program that incorporates the three programmable deficiencies listed above), it will probably be retained intact. The purpose of this memorandum is to briefly describe the computational techniques, and the input data required in order to run the program. Millers Ferry Lock, Alabama, is used for illustrative purposes. The reader is assumed to have some familiarity with the FORTRAN computer language and with time-shared computer operations.

MATHEMATICAL MODEL

4. Introduction. A definition sketch of the simulated flow conditions at time, t , during a filling operation is shown in Figure B-1. The governing equation is

$$[K_1 + K_2 + K_v(t) + K_3 + K_4] \frac{V(t)^2}{2g} = Z_u - z(t) - H_I(t) \quad (B1)$$

WESHP
SUBJECT: Engineering Summary of Lock-Filling Program "FLOCK" (Millers Ferry Prototype Test Conditions)

8 March 1974

in which
(intake, K_1 , K_2 , $K_v(t)$, K_3 , and K_4 are head loss coefficients respectively); $V(t)$ is the average velocity at a reference location in the culvert(s); g is the gravitational acceleration (32.2 ft/sec^2); Z_u is the upstream pool elevation; $z(t)$ is the elevation of the water surface in the lock chamber; and $H_I(t)$ is the head (effective inertia) required to accelerate (H_I is positive) or decelerate (H_I is negative) the flow.

5. The value of H_I for unsteady frictionless flow in a prismatic tube of length L is(1)

$$H_I = \frac{L}{g} \frac{\partial V(t)}{\partial t} \quad (B2)$$

Substituting Equation B2 in Equation B1 gives

$$[K_1 + K_2 + K_v(t) + K_3 + K_4] \frac{V(t)^2}{2g} = Z_u - z(t) - \frac{L}{g} \frac{\partial V(t)}{\partial t} \quad (B3)$$

6. The values of $z(t)$ and $V(t)$ are related by continuity, that is

$$A_1 \frac{\partial z(t)}{\partial t} = nA_c V(t) \quad (B4)$$

in which A_1 is the lock chamber water-surface area, n is the number (1 or 2) of culverts operated, and A_c is the culvert cross-sectional area. In programming "FLOCK" the value of A_c applies immediately below the valve well (i.e, before any change in area occurs); all velocity-dependent or area-dependent variables (loss coefficients, for example) are related to average conditions at this specific location.

7. Equations B3 and B4 are the basic relationships used in the lock filling. The valve loss coefficient $K_v(t)$ is a function only of valve position and, consequently, is known a priori for all t .

8. Computational sequence. All variables are known at an initial time, t_{i-1} , the time is incremented by a set amount, Δt , to the time of

WESH P

8 March 1974

SUBJECT: Engineering Summary of Lock-Filling Program "FLOCK" (Millers Ferry Prototype Test Conditions)

interest $t_i = t_{i-1} + \Delta t$. The corresponding increase in velocity, $\Delta V = V_i - V_{i-1}$ is to be determined using finite differences to simulate the differentials in Equations B3 and B4.

9. In the case of Equation B4

$$z_i = z_{i-1} + \frac{nA_c}{A_1} \left(V_{i-1} + \frac{\Delta V}{2} \right) \Delta t \quad (B5)$$

10. In the case of Equation B3, a backwards difference is used to represent the partial differential, Equation B5 if substituted for $z(t)$, and the terms are rearranged to give the following first approximation for ΔV .

$$\Delta V^2 + \Delta V \left[2V_{i-1} + \frac{2g}{K_i} \left(\frac{nA_c \Delta t}{2A_1} + \frac{L}{g\Delta t} \right) \right] + \left[V_{i-1}^2 - \frac{2g}{K_i} \left(z_u - z_{i-1} - \frac{nA_c \Delta t V_{i-1}}{A_1} \right) \right] = 0 \quad (B6)$$

ΔV is the positive real root of Equation B6; this value is used to obtain a first estimate of v_i and z_i .

11. Moving ahead one time interval and letting $\Delta V_+ = V_{i+1} - V_i$, a similar approximate solution at t_{i+1} is

$$\Delta V_+^2 + \Delta V_+ \left[2V_i + \frac{2g}{K_{i+1}} \left(\frac{nA_c \Delta t}{2A_1} + \frac{L}{g\Delta t} \right) \right] + \left[V_i^2 - \frac{2g}{K_{i+1}} \left(z_u - z_i - \frac{nA_c \Delta t V_i}{A_1} \right) \right] = 0 \quad (B7)$$

V_{i+1} is calculated once ΔV_+ , which is the positive real root of Equation B7, is known.

12. Now a central difference is used to obtain a better estimate of ΔV and of the conditions at time t_i ; that is

WESHP

8 March 1974

SUBJECT: Engineering Summary of Lock-Filling Program "FLOCK" (Millers Ferry Prototype Test Conditions)

$$\Delta V^2 + \Delta V \left[2V_{i-1} + \frac{2g}{K_i} \left(\frac{nA_c \Delta t}{2A_1} \right) \right] + \left[\frac{L(V_{i+1} - V_{i-1})}{2g\Delta t} + V_{i-1}^2 - \frac{2g}{K_i} \left(z_u - z_{i-1} - \frac{nA_c \Delta t V_{i-1}}{A_1} \right) \right] = 0 \quad (B8)$$

The program "FLOCK" solves Equations B7 and B8 sequentially to give an accurate evaluation ΔV . Equations B6, B7 and B8 provide a simple predictor-corrector numerical solution⁽²⁾ to Equation B3.

13. Starting and stopping the solution. In the program, the calculations are initiated at $i = 2$ and time $t = \Delta t$. All necessary conditions at $i - 1 = 1$ are known; that is $V_1 = t_1 = 0$ and z_1 equals the initial lock chamber water-surface elevation. The solution terminates whenever i attains a value preselected by the operator (whenever the complete filling time is not required) or whenever either ΔV or ΔV_+ has an imaginary value ($V_i < 0$)--the latter situation is a complete lock filling.

OBSERVATIONS REGARDING ACCURACY AND CONVERGENCE

14. General remarks. Several unsteady features of the flow are not included in the mathematical model--examples are oscillations of the water in the lock chamber; surging between the upstream pool, the lock chamber, and the valve wells; and pressure fluctuations below the filling valves. Cavitation below the filling valve (to the extent that the rate of flow through the valve is decreased) is also not included. In situations where these types of effects are of significance, the program will obviously generate erroneous values; on the other hand, when these effects are of a secondary nature (as usually is the case) and when the program is accurately calibrated, the calculated values appear to be as precise as any data with which they have been compared.

15. A maximum time step interval (Δt) of 15 set is recommended; Figure B-2a illustrates the effect that changing the time step size has on convergence (with regard to filling time and cavitation index*) for one test condition at Millers Ferry Lock. As indicated in Figure B-2a

* The procedure for evaluating the cavitation index is given in paragraph 30; a minimum value is of interest.

WESHP

8 March 1974

SUBJECT: Engineering Summary of Lock-Filling Program "FLOCK" (Millers Ferry Prototype Test Conditions)

the primary benefit of using a small t_i is simply to force a value of t_i to be near the time that the cavitation index is actually near its minimum value. The effects of looping through the predictor-corrector scheme for the same test conditions are tabulated below; soon after the flow begins to decelerate (after $i = 17$ in the example), the value of ΔV reaches a nearly constant value (-1.09991 in the example) and the need for the correcting procedure no longer exists.

Table B-1. Significance of the Predictor-Corrector Scheme
(Millers Ferry Tests 1, 3, and 7 Test Conditions)

<u>i</u>	<u>V_i</u> <u>f p s</u>	<u>(ΔV)₃*</u> <u>fps/15-set</u>	<u>(ΔV)₃ - (ΔV)₂</u>
1	0.00	--	--
2	3.12	3.12408	0.00000
3	6.47	3.34137	0.00000
4	9.73	3.26082	0.00000
5	13.95	4.22720	-0.00001
6	20.13	6.17296	-0.00004
7	27.40	7.27577	0.00036
8	32.97	5.56575	0.00105
9	35.47	2.49839	0.00110
10	35.04	-0.42901	0.00021
11	34.06	-0.97256	0.00005
12	32.99	-1.07507	0.00001
13	31.89	-1.09888	0.00000
14	30.80	-1.09969	0.00000
15	29.70	-1.09986	0.00000
16	28.60	-1.09990	0.00000
17	27.50	-1.09991	0.00000

* The subscripts 2 and 3 refer to the results of the second and third loop through the predictor-corrector sequence, respectively.

WESHP 8 March 1974
SUBJECT: Engineering Summary of Lock-Filling Program "FLOCK" (Millers
Ferry Prototype Test Conditions)

DATE FILE "LOCKD"

16. Introduction. All data which are needed to describe the lock geometry, the operating conditions, and the hydraulic characteristics are placed in this data file. Keyboard input during a run is limited to items having to do with the number and size of the computational steps and with plot and print options. An example of "LOCKD" is shown below; the items in the file are described in the following paragraphs.

```

100 80.34 38.77 26.00 2.00 2 MILLERS FERRY TEST NO. 5
102 377.00 10.00 10.00 655.00 84.00
104 0.20 0.05 0.70 0.25 0.13
106 2.20 3.20 0.65 0.80 0.90

```

17. The first number (100, 102, etc.) in each row is the reference line number and is not read as data. In addition, the first space following the line number is outside the format field and must be left blank.

18. Line No. 100. The format is (4F7.2, 12, 7A5); these data are read at line No. 170 in the main program "FLOCK." The items, identified by the FORTRAN symbol used in the program, are as follows:

<u>Value</u>	<u>Units</u>	<u>Symbol</u>	<u>Description</u>
80.34	Ft-Datum	ZU	Upper pool elevation
38.77	Ft-Datum	AL	Initial lock chamber elevation
26.00	Ft-Datum	ZR	Culvert roof (at valve) elevation
2.00	Minutes	VOT	Valve opening time
2	--	NC	No. of culverts operated
MILLERS, etc.	--	RUN (7)	Title of condition being studied

19. Line No. 102. The format is (5F7.2); the data are read at line No. 175 in "FLOCK." The items are as follows:

<u>Value</u>	<u>Units</u>	<u>Symbol</u>	<u>Description</u>
377.00	Ft	XL1	Length of culvert
10.00	Ft	XL2	Width of culvert (at valve)
10.00	Ft	XL3	Height of culvert (at valve)
655.00	Ft	XL4	Length of lock chamber (average)
84.00	Ft	XL5	Width of lock chamber

20. The preliminary evaluation of XL1 is simply the distance between the station at the downstream end of the intake manifold and the one at

WESHP

8 March 1974

SUBJECT: Engineering Summary of Lock-Filling Program "FLOCK" (Millers Ferry Prototype Test Conditions)

the center line of the crossover culvert (balanced flow system); or the average distance between the stations at the downstream ends of the intakes and the ones at the first lateral culverts (split lateral system). However, since irregularities in culvert geometry (location of the valve wells, expansions, etc.) also influence the inertial effect (see paragraph 5 and reference 3), the value of XL1 may be changed (usually decreased) from this simplified interpretation.

21. The amount of overfill is a measure of the momentum of the flow in the culverts; a comparison of observed and calculated (with no adjustments to the defined XL1 values) overfill follows.

<u>Symmetrical Systems</u>		<u>XL1, ft</u>	<u>Overfill, ft</u>	
			<u>Calculated</u>	<u>Observed</u>
Dardanelle prototype	(1 valve)	404.10	0.74	0.5 ⁽⁴⁾
	(2 valves)	404.10	1.14	1.1
Millers Ferry prototype	(1 valve)	377.00	0.46	0.4 ⁽⁵⁾
	(2 valves)	377.00	0.80	0.7
Bankhead model	(1 valve)	404.00	0.61	0.6 ⁽⁶⁾
	(2 valves)	404.00	0.96	1.2
<u>Nonsymmetrical System</u>				
Barkley prototype (L/W valve)	(1 valve)	650.00	1.25	0.79* ⁽⁷⁾
	(2 valves)	422.00	1.59	1.10*

* Miter gates open before maximum overfill occurs.

22. Line No. 104. The format is (5F7.2); the data are read at line No. 180 in "FLOCK." The items are as follows:

<u>Value</u>	<u>Units</u>	<u>Symbol</u>	<u>Description</u>
0.20	None	XK1	Intake loss coefficient (K_1 in Figure B-1)
0.05	None	XK2	Upstream conduit loss coefficient (K_2 in Figure B-1)
0.70	None	XK3	Downstream conduit loss coefficient (K_3 in Figure B-1)
0.25	None	XK4	Manifold loss coefficient (K_4 in Figure B-1)
0.13	None	A	Valve pattern coefficient (sag coef.)

23. The best way to precisely evaluate the loss coefficient values for an existing lock is to calibrate the program by adjusting the coefficients

WESHF 8 March 1974
SUBJECT: Engineering Summary of Lock-Filling Program "FLOCK" (Millers Ferry Prototype Test Conditions)

until a computed filling time equals a measured filling time. However, even without these data reasonably accurate, values may be obtained using the following relationships.

a. The sum of the four coefficients added to the loss coefficient of the fully open valve equals $1/c_L^2$ where C_L is the traditional lock coefficient.

b. The sum, $K_1 + K_2$, usually is approximately equal to 0.25.⁽⁸⁾

c. The values of K_2 and K_3 are estimated from the Darcy-Weisbach coefficient, fl/D , where f is the friction coefficient, l is the appropriate conduit length, and D is the hydraulic diameter of the culvert.

d. The value of K_4 is largely dependent on $(A_c/A_p)^2$ in which A_c is the culvert area and A_p is the corresponding discharge port area.

e. Minor losses (due to bends, expansions, etc.) may contribute to any of the four coefficients.

24. A brief listing of the loss coefficients for four locks is given below. For the first three locks the values are derived from items a.-e. above; for Barkley Lock the values are derived from prototype test data.

Symmetrical Systems	K_1	K_2	K_3	K_4	Kt^*	Lock Coefficient, CL	
						Program**	Observed***
Dardanelle prototype (9)							
(1 valve)	0.20	0.05	0.75	0.30	1.40	0.85	--
(2 valves)	0.20	0.05	0.75	0.70	1.80	0.75	0.66 ⁽⁴⁾
Millers Ferry prototype (10)							
(1 valve)	0.20	0.05	0.80	0.35	1.50	0.82	--
(2 valves)	0.20	0.05	0.80	0.55	1.70	0.77	0.72 ⁽⁵⁾
Bankhead model							
(1 valve)	0.20	0.05	1.18	0.20	1.73	0.76	--
(2 valves)	0.20	0.05	1.18	0.70	2.23	0.67	0.67 ⁽⁶⁾

EM 1110-2-1610
15 Aug 75

WESHP 8 March 1974
SUBJECT: Engineering Summary of Lock-Filling Program "FLOCK" (Millers
Ferry Prototype Test Conditions)

Non-symmetrical System	<u>K₁</u>	<u>K₂</u>	<u>K₃</u>	<u>K₄</u>	<u>Kt*</u>	Lock Coefficient, C _L	
						<u>Program**</u>	<u>Observed***</u>
Barkley prototype(7)							
(1 valve)	0.20	0.08	0.42	0.86	1.66	0.78	--
(2 valves)	0.20	0.08	0.22	0.86	1.46	0.83	0.75 ⁽¹¹⁾

* K_t = K₁ + K₂ + K₃ + K₄ + K_v(t_v); 0.10 is the value assumed for K_v(t_v) .

** C_L = $\sqrt{1/K_t}$.

*** The observed values of C_L are from model tests.

25. The valve opening pattern is approximated by the following equation:

$$\frac{b}{B} = \frac{t}{t_v} - A \sin \left(\frac{\pi t}{t_c} \right) \quad (B9)$$

in which b/B is the valve-opening ratio (B = XL3 = culvert height); t/t_v is valve-time ratio (t_v = VOT = valve opening time); and A is the sag coefficient. The calculation is at line No. 240 in "FLOCK." The value of A is obtained from the valve opening pattern; A equals (0.5 - b/B) at t/t_v = 0.5 .

<u>Lock</u>	<u>A</u>	<u>Comment</u>
Dardanelle	0.21	Large sag
Millers Ferry	0.13	
Bankhead	0.08	Small sag
Barkley	0.14	

26. The valve opening pattern for Millers Ferry Lock is shown in Figure B-2b.

27. Line No. 106. The format is (5F7.2); the data are read at line No. 185 in "FLOCK." These values (termed B*, C, D, E, and F, respectively) are used to fit a succession of curves to the valve loss coefficient (B*, C) and the valve contraction coefficient (D, E, F) as a function of valve opening. For data analysis purposes, the effects of

WESHHP

8 March 1974

SUBJECT: Engineering Summary of Lock-Filling Program "FLOCK" (Millers Ferry Prototype Test Conditions)

altering these values are often of interest; for design purposes the tabulated values are adequate.

28. The valve loss coefficient is approximated (as shown in Figure B-3) as follows:

$$(a) \quad \frac{b}{B} = 0 \quad K_v = 10000.$$

$$(b) \quad 0 < \frac{b}{B} < 0.2 \quad K_v = \frac{0.04}{\left(\frac{b}{B}\right)^2} (10^{B^*-0.2C}) \quad (B10)$$

$$(c) \quad 0.2 \leq \frac{b}{B} \leq 1.0 \quad K_v = 10^{B^*-C(b/B)} \quad (B11)$$

29. The following three points pertain to the above conditions as used in the computer program.

a. The value at $b/B = 0$ is not used in the calculations; it is only used to fill out the array of K_v values to simplify the programming.

b. The functions (b) and (c) are single valued and are equal at $b/B = 0.2$; the corresponding derivatives (which are not used in programming) are not equal at $b/B = 0.2$.

c. The value at $b/B > 1.0$ is the loss coefficient due to the valve well and the full open valve.

30. As used in "FLOCK" the contraction coefficient, C_c , is a parameter needed for calculating the piezometric head, $\left(\frac{p}{\gamma} + Z\right)_r$ at the roof of the culvert immediately downstream from the filling valve and the cavitation index, C_i , for the low pressure region below the valve. The expressions used to compute these values are:

$$\left(\frac{p}{\gamma} + Z\right)_r = Z_u - (K_1 + K_2) \frac{V^2}{2g} - \left(\frac{B}{C_c b}\right)^2 \frac{V^2}{2g} \quad (B12)$$

15 Aug 75

WESHP

8 March 1974

SUBJECT: Engineering Summary of Lock-Filling Program "FLOCK" (Millers Ferry Prototype Test Conditions)

$$C_i = \frac{p}{\gamma_r} + 33.0 - B \left(1 - \frac{C_c b}{B} \right) \left(\frac{C_c b}{B} \right)^2 \sqrt{\frac{v^2}{2g}} \quad (B13)$$

31. Since the flow pattern below the valve changes as the valve opens, published contraction coefficient values are appropriately used in Equation B11 only at intermediate values of b/B , say $0.3 < b/B < 0.7$. To fill in the values outside this range as well as to provide a reference set of values for C_c at the intermediate openings (the published data show considerable scatter) the following equations are used

$$0 \leq \frac{b}{B} \leq 0.2 ; \quad C_c = D + (E-D) \cos \left(\frac{\pi b}{0.6B} \right) \quad (B14)$$

$$0.2 < \frac{b}{B} ; \quad C_c = F - (F-D) \cos \left(\pi \frac{b - 0.3B}{1.4B} \right) \quad (B15)$$

32. The intermediate values of C_c are sensitive to the value of the parameter, D , in Equations B14 and B15; simulations of model and prototype test conditions have shown that the values 0.65, 0.8, and 0.9 for D , E , and F , respectively, are adequate for most design purposes--the corresponding curves are shown in Figure B-4.

33. Program Output. Three unsubscripted variables are computed and printed as follows:

Program Variable Name	Description
XKT	XKT is the sum of the loss coefficients; i.e., $XKT = K_t$ in paragraph 24.
I	I is a variable subscript; for example filling time is between $(I-2)\Delta t$ and $(I-1)\Delta t^*$ during the filling operation.
ZOT	Lock chamber overflow; ZOT is the difference between the lock-chamber water-surface and the upper pool elevations at time $M\Delta t$ where M is a value of I that terminates the computations.

* Δt is the incremental time.

WESHP

8 March 1974

SUBJECT: Engineering Summary of Lock-Filling Program "FLOCK" (Millers Ferry Prototype Test Conditions)

34. The subscripted output variables are as follows:

Program Variable Name	Dimensions	Evaluation--Dimension Conversions Are Omitted Here
CI	--	Equation B13, C
H	Ft	$Z_u - z_i$
HI	Ft	Equation B2, H_I
HL1	Ft	$K_1 V^2/2g$
HL2	Ft	$K_2 V^2/2g$
HL3	Ft	$K_3 V^2/2g$
HL4	Ft	$K_4 V^2/2g$
HLT	Ft	$K_t V^2/2g$
HLV	Ft	$K_{vi} V^2/2g$
PVC	Ft	Equation B12, $(P/\gamma)_r$
Q	Ft ³ /sec	$nV_i A_c$
RUN	--	Title (see para. 18)
RR	Ft/min	Q/A_λ
V	Ft/sec	$V_{i-1} + \Delta V$
VH	Ft	$V^2/2g$
XBB	--	Equation B8, b/B
xcc	--	Equations B14 and B15, C_c
XKV	--	Equations B10 and B11, K_v
XT	Min	$t_{i-1} + \Delta t$
Z	Ft-Datum	Equation B5, z
zv	Ft-Datum	$(p/\gamma + Z)_r$
zw	Ft-Datum	$Z_u - (1 + K_1 + K_2)V^2/2g$

EM 1110-2-1610
15 Aug 75

WESH P

8 March 1974

SUBJECT: Engineering Summary of Lock-Filling Program "FLOCK" (Millers
Ferry Prototype Test Conditions)

STATUS

35. The program is set up for 600-series time-sharing computer operation at the U. S. Army Engineer Waterways Experiment Station.

Frank M. Neilson
Engineer
Analysis Branch

References.

1. Rouse, H., Elementary Mechanics of Fluids, Wiley, New York, 1946, pp 125-132.
2. Herriot, J. G., Methods of Mathematical Analysis and Computation, Wiley, New York, 1963, pp 139-140.
3. Pillsburg, G. B., "Excess Head in the Operation of Large Locks Through the Momentum of the Column of Water in the Culverts," U. S. Army Corps of Engineers Professional Memoirs, Vol 7, Nos. 31-36, 1915, pp 206-212.
4. Ables, J. H., Jr., and Boyd, M. B., "Filling and Emptying System, Dardanelle Lock, Arkansas River; Hydraulic Model Investigation," Technical Report H-69-5, Apr 1969, U. S. Army Engineer Waterways Experiment Station, CE, Vicksburg, Miss.
5. Ables, J. H., Jr., and Boyd, M. B., "Filling and Emptying Systems, Millers Ferry and Jones Bluff Locks, Alabama River, Alabama; Hydraulic Model Investigation," Technical Report No. 2-718, Mar 1966, U. S. Army Engineer Waterways Experiment Station, CE, Vicksburg, Miss.
6. Ables, J. H., Jr., Murphy, T. E., and Oswalt, N. R., "Navigation Conditions and Filling and Emptying System, New Bankhead Lock, Black Warrior River, Alabama; Hydraulic Model Investigation," Technical Report H-72-6, Sep 1972, U. S. Army Engineer Waterways Experiment Station, CE, Vicksburg, Miss.

WESHHP

8 March 1974

SUBJECT: Engineering Summary of Lock-Filling Program "FLOCK" (Millers
Ferry Prototype Test Conditions)

References. (Continued)

7. Neilson, F. M., "Barkley Lock Prototype Tests" (in preparation), U. S. Army Engineer Waterways Experiment Station, CE, Vicksburg, Miss.
8. Murphy, T. E., Personal communication dated Nov 1973.
9. Pugh, C. J., "Trip Report, Dardanelle Lock, Arkansas River, Prototype Tests, 6-7 February 1974," Memorandum for Record, 11 Feb 1974, U. S. Army Engineer Waterways Experiment Station, CE, Vicksburg, Miss.
10. Neilson, F. M., "Trip Report, Millers Ferry Lock, Alabama River, 8-9 November 1973" (in preparation), U. S. Army Engineer Waterways Experiment Station, CE, Vicksburg, Miss.
11. Fidelman, S., "Filling and Emptying Systems for Barkley Lock, Cumberland River, Kentucky; Hydraulic Model Investigation," Hydraulic Laboratory Report No. 75, Jun 1963, U. S. Army Engineer District, St. Paul, Minn.; prepared by St. Anthony Falls Hydraulic Laboratory, Minneapolis, Minn.

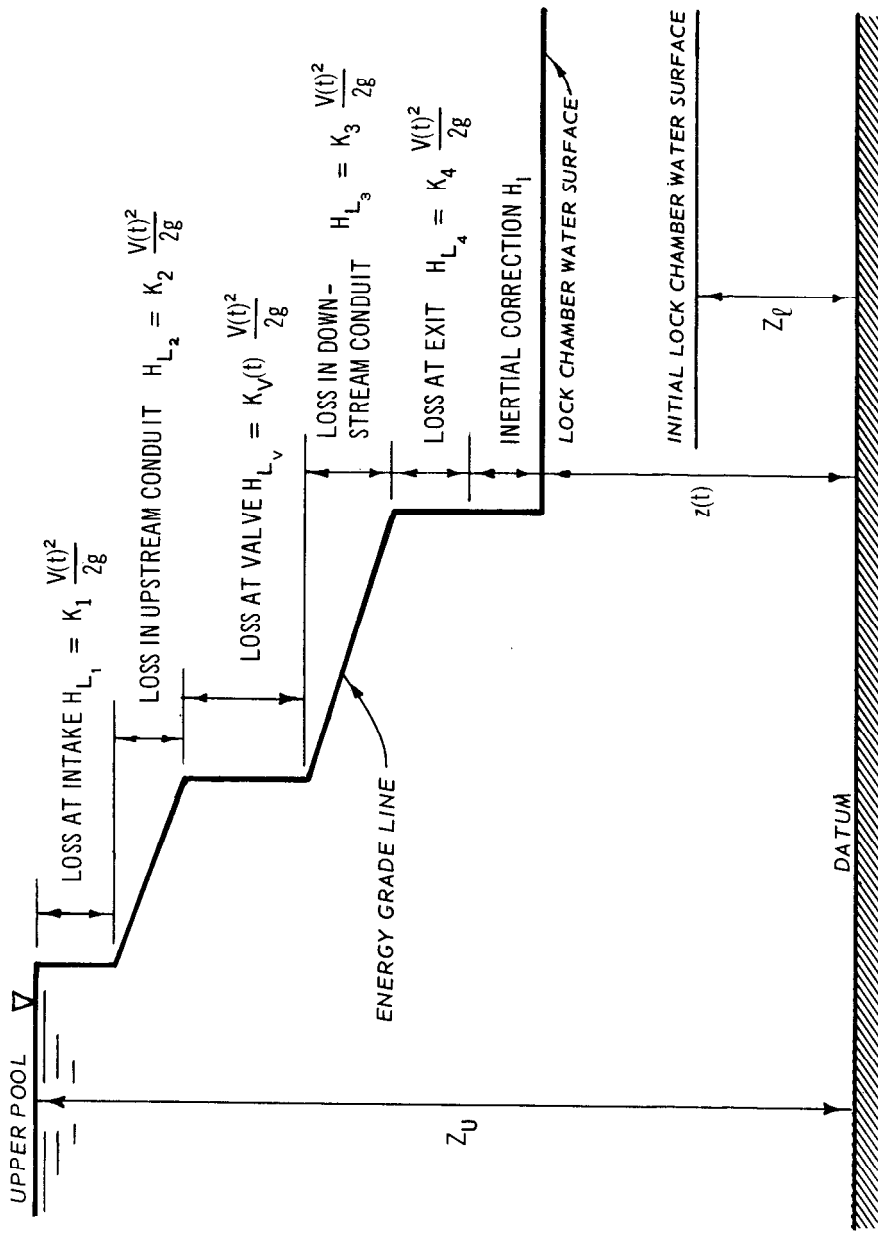

Figure B-1. Simulated flow conditions at time t

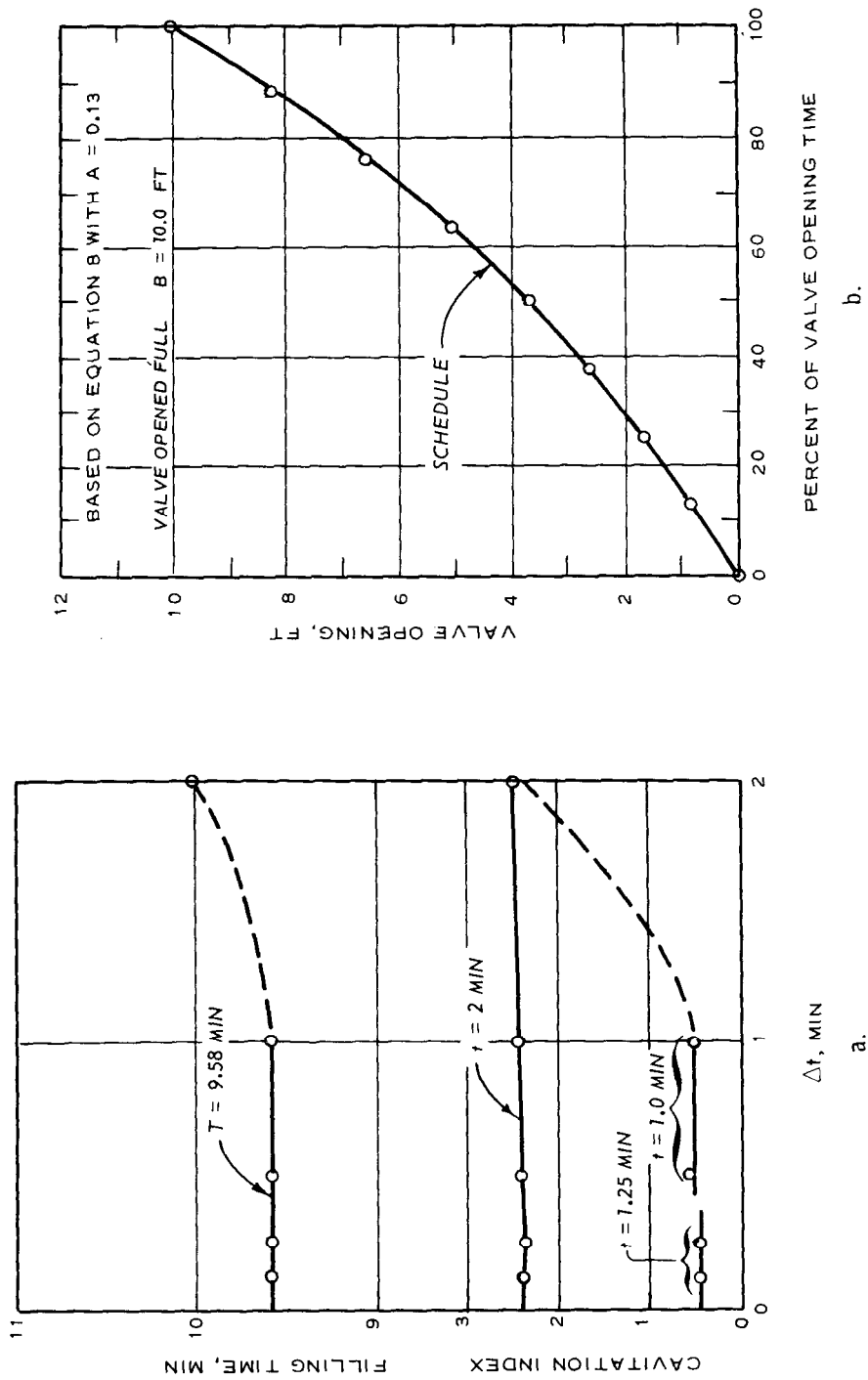

Figure B-2. Effect of time step size on accuracy (a) and valve opening pattern (b) at Millers Ferry Lock

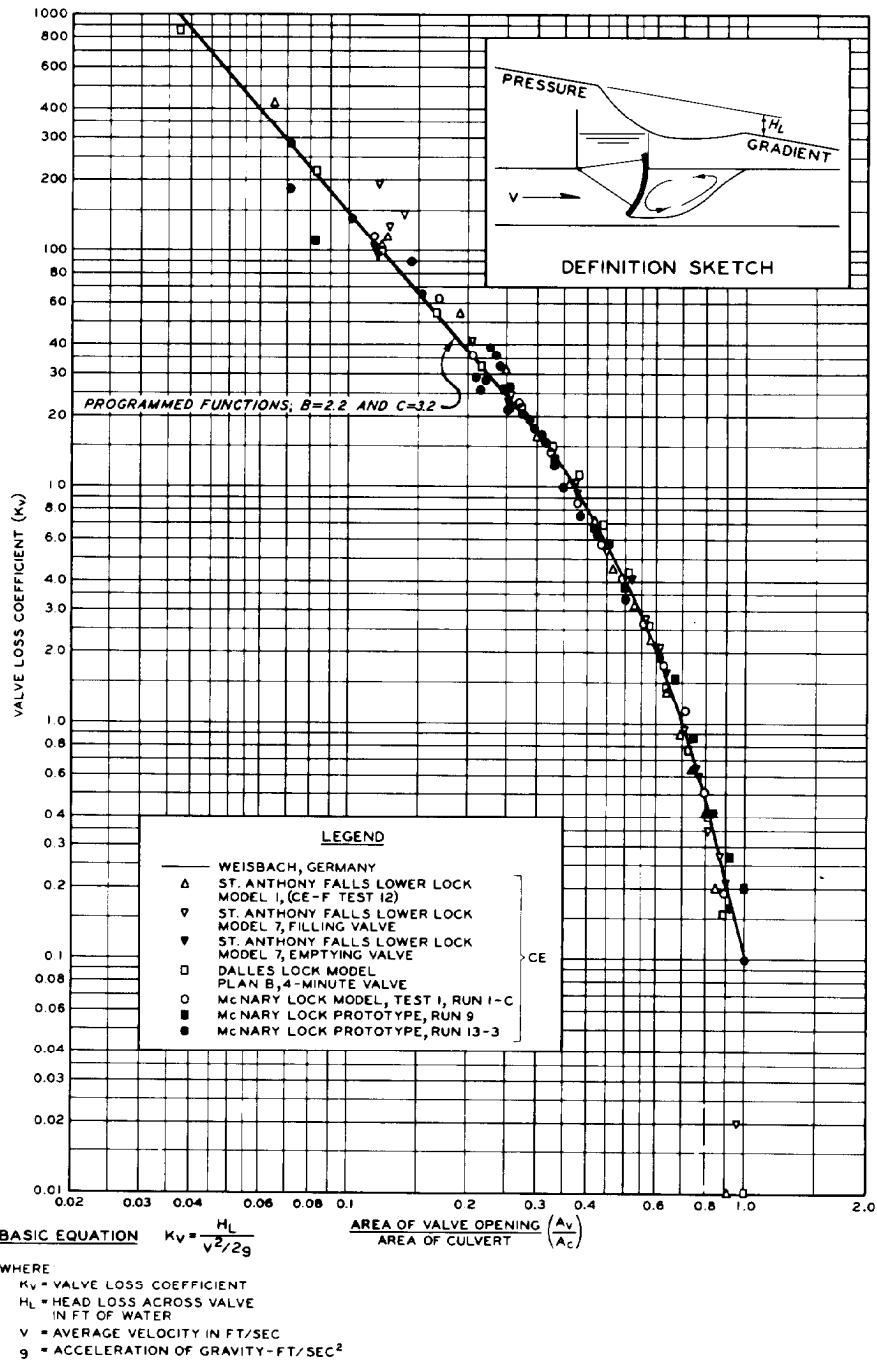

Figure B-3. Loss coefficient

15 Aug 75

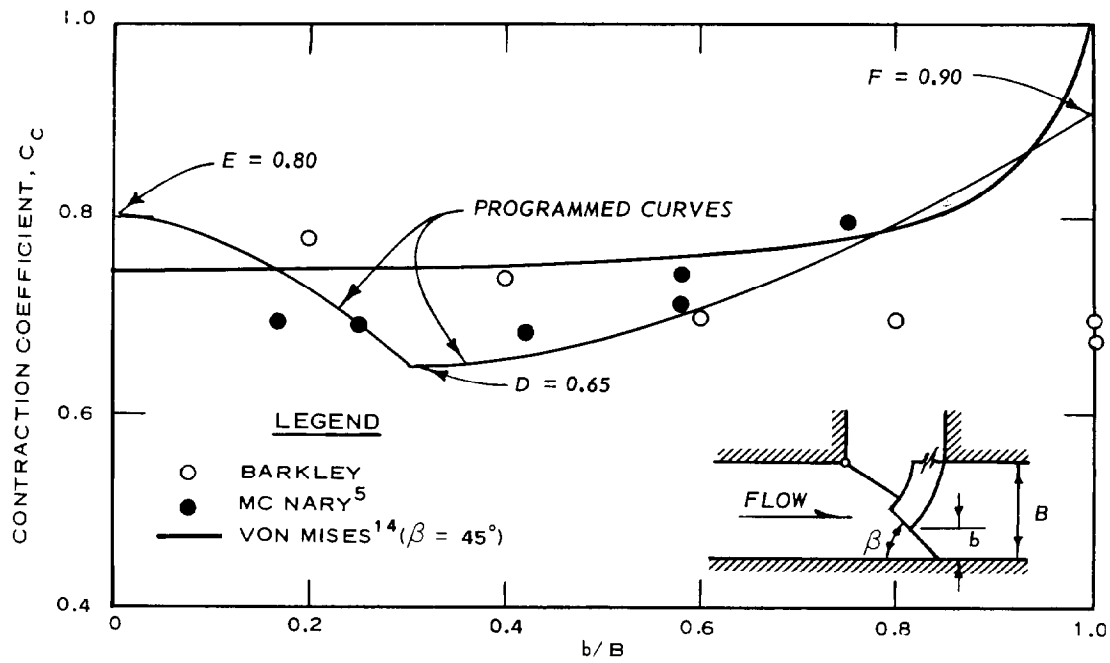

Figure B-4. Reverse tainter valve contraction coefficient

APPENDIX C

DESIGN EXAMPLES

C-1. Problem. Determine maximum elevation of culvert at filling valves for cavitation-free operation.

EXAMPLE 1

C-2. Data Previously Developed.

Upper pool - el 160
 Lower Pool - el 120
 Lift - 40 ft
 Lock Chamber - 670 ft by 110 ft
 Two Culverts
 Valves 12.5 by 12.5 ft
 Loss Coefficients for Filling

Intake	0.200 $V^2/2g$
Upstream conduit	0.050 $V^2/2g$
Downstream conduit	0.380 $V^2/2g$
Chamber manifold	1.000 $V^2/2g$
Total (valve open)	1.730 $V^2/2g$

C-3. Solution.

a. Develop Hydraulic Data. Assume culvert roof at filling valves at el 115 and no roof expansion downstream from the valves. (This is the maximum elevation permissible dictated by criterion of 5 ft of submergence of the culvert system at lower pool.) Use computer program (Appendix B) to develop hydraulic conditions during filling. Data from these computations pertinent to this example are listed in table C-1.

Table C-1

Time min	Valve Open %	Contraction Coefficient	Inflow cfs	At Vena Contracta	
				Pressure Gradient el	Pressure on Culvert Roof, ft
0.0	0.000	0.800	0	120.0	5.00
0.1	0.025	0.799	322	118.6	3.61
0.2	0.051	0.795	650	118.4	3.37
0.3	0.077	0.788	991	117.9	2.94
0.4	0.106	0.778	1,350	117.2	2.25

(Continued)

Table C-1 (Continued)

Time min	Valve Open %	Contraction Coefficient	Inflow cfs	At Vena Contracta	
				Pressure Gradient el	Pressure on Culvert Roof, ft
0.5	0.137	0.763	1,731	116.2	1.22
0.6	0.171	0.744	2,138	114.7	-0.30
0.7	0.207	0.720	2,554	113.2	-1.76
0.8	0.248	0.690	2,928	113.1	-1.90
0.9	0.292	0.656	3,375	110.2	-4.78
1.0	0.340	0.651	3,916	109.6	-5.39
1.1	0.392	0.655	4,565	108.9	-6.06
1.2	0.448	0.664	5,326	107.8	-7.20
1.3	0.507	0.677	6,188	106.8	-8.18
1.4	0.571	0.695	7,117	106.7	-8.29
1.5	0.637	0.718	8,053	108.1	-6.88
1.6	0.706	0.747	8,918	111.3	-3.67
1.7	0.777	0.780	9,641	116.1	1.13
1.8	0.851	0.818	10,179	121.8	6.83
1.9	0.925	0.858	10,530	127.6	12.61
2.0	1.000	0.900	10,746	132.7	17.74

b. Determine Minimum Value of Cavitation Parameter, K . From consideration of pressures in table C-1, it appears that K should be minimum within the time period of 1.2 to 1.5 min. Thus, from data in table C-1:

Table C-2

Time min	Valve Open ft	At Vena Contracta			P‡ ft	K See para 2-2b
		Depth-t ft	V†† fps	V ² /2g		
1.2	5.60	3.72	57.29	50.97	1.58	0.678
1.3	6.34	4.29	57.69	51.68	0.03	0.639
1.4	7.14	4.96	57.39	51.14	-0.75	0.631
1.5	7.96	5.72	56.34	49.29	-0.10	0.668

- † Valve open in feet times contraction coefficient.
- †† Inflow divided by product of number of culverts (2) times width of a culvert (12.5 ft) times depth at vena contracta.
- ‡ Pressure on culvert roof plus depth of culvert (12.5 ft) minus depth at vena contracta.

Since the minimum value of K , 0.631, is less than K_i 1.000 (fig. 2-1) the culvert must be lowered or expanded along the roof & immediately downstream from the valve.

c. Determine Elevation for Level Roof. Pressure required at vena contracta for minimum K to equal K_i is determined from equation for cavitation parameter (para 2-2b).

$$1.000 = \frac{P + 33}{51.14}$$

$$P = 18.14 \text{ ft}$$

Then the roof of the culvert must be at the elevation of the lower pool minus the pressure drop (table C-1, 120.00 - 106.7 = 13.30 ft), minus p , plus distance from vena contracta to roof of culvert (12.5 - depth of vena contracta) or el 120.00 - 13.30 - 18.14 + 12.5 - 4.96 = el 96.10. but factor of safety (para 2-3a, one-tenth lift) of 4.00 ft, should be subtracted and therefore culvert roof must not be higher than el 92.10.

d. Determine Elevation for Roof at Valve with Culvert Roof Downstream Sloped Up 5.0 ft (40% Expansion). From figure 2-1, $K_i = 0.470$. Loss coefficients in paragraph C-2 must be reevaluated and, for this example, become:

Intake	0.200 $V^2/2g$
Upstream conduit	0.050 $V^2/2g$
Downstream conduit	0.320 $V^2/2g$
Chamber manifold	0.630 $V^2/2g$
Total (valve open)	1.300 $V^2/2g$

e. Develop New Hydraulic Data and Determine Elevation for Expanded Roof. Computations outlined in paragraphs C-3a and C-3b are repeated. Again K is minimum at a time of 1.4 min but at the vena contracta the pressure drop now is 18.4 ft and the velocity head is 55.48 ft. As in paragraph C-3c:

$$0.470 = \frac{P + 33}{55.48}$$

$$P = -6.92$$

Culvert roof at valve: el 120.00 - (-6.92) - 18.4 + 12.5 - 4.96
= el 116.06 - 4.0 (safety factor) = el 112.06

15 Aug 75

Since this would place the roof of the expanded culvert at el 117.06, less than 5 ft below lower pool, the culvert roof at the valve must not be higher than el 110, that required for minimum submergence.

f. Maximum Feasible Elevation for Culvert Roof. An expansion of 4.25 ft would result in the requirements for no cavitation plus the safety factor matching the criterion for minimum submergence of the culvert system and would place the culvert roof at the valves at the maximum feasible elevation of 110.75.

EXAMPLE 2

C-4. Data Previously Developed. Identical to Example 1 except upper pool at el 180 and thus lift of 60 ft.

C-5. Solution.

a. Level Roof. Computations as in Example 1 reveal that with a level roof and a safety factor of 6.0 ft (one-tenth lift) the culvert roof must be placed no higher than el 51.69 to provide submergence needed to prevent cavitation. An alternative would be to provide air vents downstream from the valve and place the culvert at an elevation where air will be drawn in the vents during the critical portion of the valve opening period. Computations have revealed that the pressure drop (lower pool to minimum gradient at vena contracta) would be 23.10 ft. Thus to provide the desired 10 ft of negative pressure on the roof (para 2-3a) the culvert roof should be 13.10 below lower pool or at el 106.90.

b. Roof Sloped Up 5 ft (40% Expansion). If the roof is sloped up 5 ft, loss coefficients are reevaluated as in paragraph C-3d and computations indicate that the roof of the culvert at the valves can be placed no higher than el 81.76 to meet submergence requirements for cavitation-free operation. In this case, if the alternative of providing air vents is adopted then the recomputed pressure drop, 31.80 ft, must be reduced by 58% (fig. 2-2) due to the 40% culvert expansion. Thus the pressure drop becomes 13.4 ft and to provide 10 ft of negative pressure would require placing the roof of the culvert at the valves only 3.4 ft below lower pool. Obviously, this does not meet minimum submergence requirements and expansion of the roof by 5 ft is not feasible for venting.

C-6. Maximum Feasible Elevation for Culvert Roof. For this example, a roof expansion of 2.75 ft would be optimum and would allow the vented roof of the culvert at the valve to be at el 112.25.