

**Naval Surface Warfare Center
Carderock Division**
West Bethesda, MD 20817-5700

NSWCCD-50-TR-2002/012 February 2002

Hydromechanics Directorate
Technical Report

**ADVANCED HULL FORM INSHORE DEMONSTRATOR
Model Strut and Propulsor Performance in Uniform Flow**

by
KIRK J. ANDERSON
CARMEN G. BORDA
MARTIN J. DONNELLY

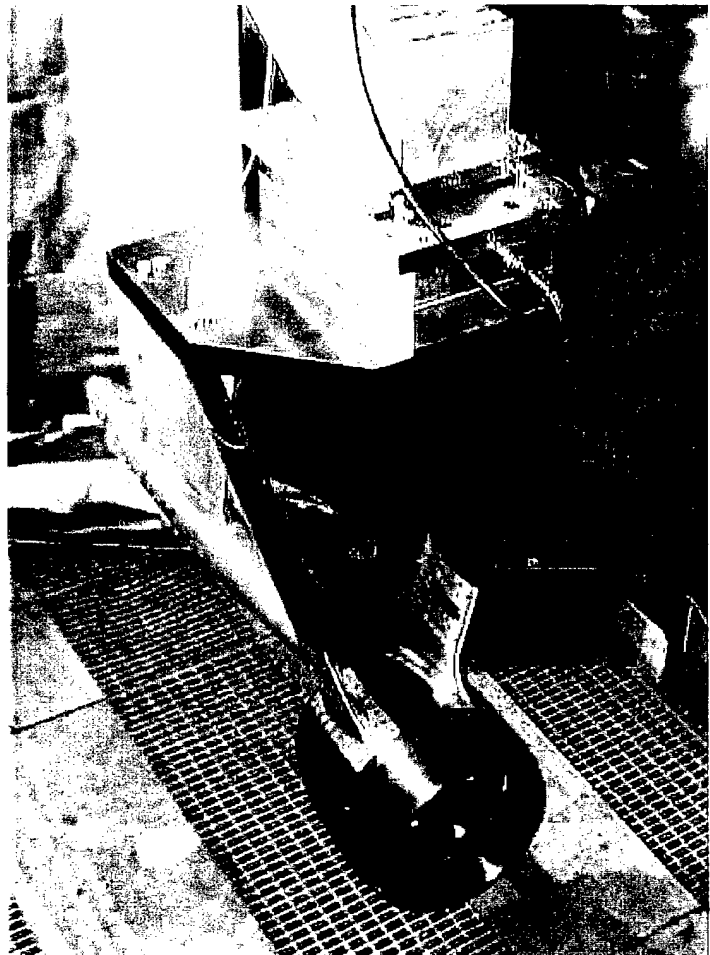

ADVANCED HULL FORM INSHORE DEMONSTRATOR
Model Strut and Propulsor Performance in Uniform Flow

NSWCCD-50-TR-2002/012



Approved for public release; distribution is unlimited.

20020517 022

REPORT DOCUMENTATION PAGE

Form Approved
OMB No. 0704-0188

Public reporting burden for this collection of information is estimated to average 1 hour per response, including the time for reviewing instructions, searching existing data sources, gathering and maintaining the data needed, and completing and reviewing this collection of information. Send comments regarding this burden estimate or any other aspect of this collection of information, including suggestions for reducing this burden to Department of Defense, Washington Headquarters Services, Directorate for Information Operations and Reports (0704-0188), 1215 Jefferson Davis Highway, Suite 1204, Arlington, VA 22202-4302. Respondents should be aware that notwithstanding any other provision of law, no person shall be subject to any penalty for failing to comply with a collection of information if it does not display a currently valid OMB control number. PLEASE DO NOT RETURN YOUR FORM TO THE ABOVE ADDRESS.

1. REPORT DATE (DD-MM-YYYY) 17-Feb-2002	2. REPORT TYPE Final	3. DATES COVERED (From - To) 20-Jul-2001 - 14-Dec-2001
--------------------------------------------	-------------------------	-----------------------------------------------------------

4. TITLE AND SUBTITLE ADVANCED HULL FORM INSHORE DEMONSTRATOR Model Strut and Propulsor Performance in Uniform Flow	5a. CONTRACT NUMBER
	5b. GRANT NUMBER
	5c. PROGRAM ELEMENT NUMBER

6. AUTHOR(S) Kirk J. Anderson, Carmen G. Borda, Martin J. Donnelly	5d. PROJECT NUMBER WPP-54-0194
	5e. TASK NUMBER
	5f. WORK UNIT NUMBER 1-5400-802

7. PERFORMING ORGANIZATION NAME(S) AND ADDRESS(ES) AND ADDRESS(ES) Naval Surface Warfare Center Carderock Division 9500 Macarthur Boulevard West Bethesda, MD 20817-5700	8. PERFORMING ORGANIZATION REPORT NUMBER NSWCCD-50-TR-2002/012
--------------------------------------------------------------------------------------------------------------------------------------------------------------------------------------	-------------------------------------------------------------------

9. SPONSORING / MONITORING AGENCY NAME(S) AND ADDRESS(ES) GENERAL DYNAMICS Electric Boat Corporation 75 Eastern Point Road Groton, CT 06340-4989	10. SPONSOR/MONITOR'S ACRONYM(S)
	11. SPONSOR/MONITOR'S REPORT NUMBER(S)

12. DISTRIBUTION / AVAILABILITY STATEMENT
Approved for public release; distribution is unlimited.

13. SUPPLEMENTARY NOTES

14. ABSTRACT
An experimental program was conducted at the Carderock Division Naval Surface Warfare Center (NAVSURFWARCEN CARDEROCKDIV) in support of the Advanced Hull Form Inshore Demonstrator (AHFID) ship for the Electric Boat Corporation. The objective of this work was to predict the ahead performance of a ducted propulsor and support struts designed for the AHFID in uniform inflow. Numerical and graphical results are presented. No anomalous performance characteristics were revealed. The total thrust and torque of the propulsor measured in the experiments should give an accurate indication of how the full-scale unit would perform in uniform flow.

15. SUBJECT TERMS
Advanced Hull Form Inshore Demonstrator, AHFID, Ducted Propulsor, Uniform Flow, Open Water

16. SECURITY CLASSIFICATION OF:			17. LIMITATION OF ABSTRACT SAR	18. NUMBER OF PAGES 74	19a. NAME OF RESPONSIBLE PERSON Kirk J. Anderson
a. REPORT UNCLASSIFIED	b. ABSTRACT UNCLASSIFIED	c. THIS PAGE UNCLASSIFIED			19b. TELEPHONE NUMBER (include area code) 301-227-4308

This page was intentionally left blank.

CONTENTS

	Page
NOTATION	vi
ABSTRACT	1
ADMINISTRATIVE INFORMATION	1
INTRODUCTION	1
DESCRIPTION OF PROPELLER	2
EXPERIMENTAL SET-UP	3
EXPERIMENTAL PROCEDURES	4
Bollard Pull	4
Reynolds Number Variation	4
Open Water	5
Oil Paint Flow Visualization	5
Strut Forces	6
PRESENTATION OF RESULTS	6
Bollard Pull	6
Reynolds Number Variation	7
Open Water	7
Oil Paint Flow Visualization	9
Strut Forces	9
CONCLUSIONS	9
APPENDIX A - EXPERIMENTAL PROCEDURES, ACCURACY AND UNCERTAINTY	47
APPENDIX B - PHOTOGRAPHS OF STRUT SPRAY AND WAVES	49
APPENDIX C - FLOW VISUALIZATION PHOTOGRAPHS	55
REFERENCES	63
INITIAL REPORT DISTRIBUTION	65

FIGURES

	Page
1. Sketch of the AHFID Propulsor	11
2. Drawing of the Model Propulsor Assembly	12
3. Drawing of the Test Set-up	13
4. Photographs of the Test Set-up	14
5. Photograph Showing the Light Rubbing on the Model	15
6. Photographs of the Strut Fairing End Caps	16
7. Bollard Pull Data at 0° of Pitch Presented as Thrust & Torque Coefficients	17
8. Bollard Pull Data at 0° of Pitch Presented as Thrust & Torque Indexes	18
9. Reynolds Number Variation Data at 0° of Pitch Presented as Thrust & Torque Coefficients	19
10. Reynolds Number Variation Data at 0° of Pitch Presented as Thrust & Torque Indexes	20
11. Open Water Rotor Performance Data at 0° of Pitch	21
12. Open Water Propulsor Performance Data at 0° of Pitch	22
13. Open Water Propulsor and Strut Assembly Performance Data at 0° of Pitch	23
14. Open Water Duct and Strut Assembly Performance Data at 0° of Pitch	24
15. Open Water Rotor Performance Data at 0° of Pitch; KTP, KQ, and ETAP	25
16. Open Water Propulsor Performance Data at 0° of Pitch; KTT, KQ, and ETAT	26
17. Open Water Rotor Performance Data at 6.5° of Pitch	27
18. Open Water Propulsor Performance Data at 6.5° of Pitch	28
19. Open Water Propulsor and Strut Assembly Performance Data at 6.5° of Pitch	29
20. Open Water Duct and Strut Assembly Performance Data at 6.5° of Pitch	30
21. Open Water Rotor Performance Data at 6.5° of Pitch; KTP, KQ, and ETAP	31
22. Open Water Propulsor Performance Data at 6.5° of Pitch; KTT, KQ, and ETAT	32
23. Strut Drag Results Presented in Physical Units	33
24. Strut Drag Results Presented in Coefficient Form	34

FIGURES - Continued

	Page
A-1. Drawing of the 6-Component Dynamometer Coordinate System	48
B-1. Strut Wave and Spray at 4 ft/sec, 0 degree pitch	50
B-2. Strut Wave and Spray at 8 ft/sec, 0 degree pitch	51
B-3. Strut Wave and Spray at 12 ft/sec, 0 degree pitch	52
B-4. Strut Wave and Spray at 16 ft/sec, 0 degree pitch	53
B-5. Strut Wave and Spray at 20 ft/sec, 0 degree pitch	54
C-1. Paint Applied before the Flow Visualization Run	56
C-2. Paint Flow on the Forward End of the Unit, 0 degree pitch	57
C-3. Paint Flow on the Aft End of the Unit, 0 degree pitch	58
C-4. Paint Flow on the Suction Side of the Rotor Blade, 0 degree pitch	59
C-5. Paint Flow on the Pressure Side of the Rotor Blade, 0 degree pitch	60
C-6. Paint Flow on the Outside of the Duct, 0 degree pitch	61

TABLES

1. Bollard Pull Data	35
2. Reynolds Number Variation Data	36
3. Open Water Propulsor Performance Data at 0 degree of Pitch	37
4. Open Water Duct and Strut Assembly Performance Data at 0 degree of Pitch	38
5. Open Water Propulsor Performance Data at 0 degree of Pitch Presented as Thrust & Torque Coefficients	39
6. Open Water Propulsor Performance Data at 6.5 degree of Pitch	40
7. Open Water Duct and Strut Assembly Performance Data at 6.5 degree of Pitch	41
8. Open Water Propulsor Performance Data at 6.5 degree of Pitch Presented as Thrust & Torque Coefficients	42
9. Comparison of Open Water Performance Results for the AHFID Propulsor	43
10. Strut Drag Results in Faired Physical Units	44
11. Strut Drag Results in Coefficient Form	45

NOTATION

The notations used in this document are consistent with the International Towing Tank Conference ITTC Standard Symbols from the "International Towing Tank Conference ITTC Symbols and Terminology List, Final Version 1996." Prepared by the 21st ITTC Symbols and Terminology Group; Edited and Produced by Bruce Johnson, U. S. Naval Academy, Annapolis, MD 21402-5042, USA.

A_O, A_O	Rotor Disc Area, $[\pi D^2/4]$
$\beta^*, BETA^*$	Effective advance angle $[\arctg(V_A/(0.7R\omega))]$
C_{FX}, C_{FX}	Axial Force Index along the X axis, $[F_X/A_Oq_S]$
C_{FY}, C_{FY}	Side Force Index along the Y axis, $[F_Y/A_Oq_S]$
C_{FZ}, C_{FZ}	Lift Force Index along the Z axis, $[F_Z/A_Oq_S]$
C_{MX}, C_{MX}	Moment Index about the X axis, $[M_X/DA_Oq_S]$
C_{MY}, C_{MY}	Moment Index about the Y axis, $[M_Y/DA_Oq_S]$
C_{MZ}, C_{MZ}	Moment Index about the Z axis, $[M_Z/DA_Oq_S]$
C_Q, C_Q	Rotor Torque Loading Coefficient, $[Q/DA_Oq_A]$
C_{Q^*}, C_{Q^*}	Rotor Torque Index, $[Q/DA_Oq_S]$
C_{TALL^*}, C_{TALL^*}	Propulsor & Strut Assembly Thrust Index, $[(T_P + F_X)/A_Oq_S]$
C_{TD^*}, C_{TD^*}	Duct & Stator Thrust Index, $[T_D/A_Oq_S]$
C_{TP}, C_{TP}	Rotor Thrust Loading Coefficient, $[T_P/A_Oq_A]$
C_{TP^*}, C_{TP^*}	Rotor Thrust Index, $[T_P/A_Oq_S]$
C_{TT}, C_{TT}	Total Ducted Propulsor Thrust Loading Coefficient, $[T_P + T_D/A_Oq_A]$
C_{TT^*}, C_{TT^*}	Total Ducted Propulsor Thrust Index, $[T_P + T_D/A_Oq_S]$
D	Reference diameter used in calculations
F_X, F_X	Axial Force along X axis of a coordinate system
F_Y, F_Y	Side Force along Y axis of a coordinate system
F_Z, F_Z	Lift Force along Z axis of a coordinate system
J	Propeller Advance Coefficient, $[V_A/(nD)]$
K_Q, K_Q	Propeller Torque Coefficient, $[Q/(\rho n^2 D^5)]$
K_T, K_T	Propeller Thrust Coefficient, $[T/(\rho n^2 D^4)]$
K_{TD}, K_{TD}	Duct & Stator Thrust Coefficient, $[T_D/(\rho n^2 D^4)]$
K_{TP}, K_{TP}	Rotor Thrust Coefficient, $[T_P/(\rho n^2 D^4)]$
K_{TT}, K_{TT}	Total Ducted Propulsor Thrust Coefficient, $[(T_P + T_D)/(\rho n^2 D^4)]$
K_{TALL}, K_{TALL}	Propulsor & Strut Assembly Thrust Coefficient, $[(T_P + F_X)/(\rho n^2 D^4)]$
M_X, M_X	Moment about the X axis of a reference coordinate system

NOTATION – Continued

M_Y, MY	Moment about the Y axis of a reference coordinate system
M_Z, MZ	Moment about the Z axis of a reference coordinate system
n	Revolutions per Second
Q	Rotor torque
q_A	Dynamic pressure based on advance speed $[(\rho V_A^2)/2]$
q_S	Dynamic pressure based on the 70% rotor radius advance speed $[(\rho V_S^2)/2]$
R	Reference radius used in calculations (D/2)
Rn	Reynolds Number, VL/v
T_D, TD	Total duct & stator axial force, $TDS+TDP$
T_{DP}, TDP	Duct & stator axial force measured on the port strut gage
T_{DS}, TDS	Duct & stator axial force measured on the starboard strut gage
T_P	Rotor thrust
V	Reference Velocity
V_A, VA	Advance speed of the propeller, $[V(1-w_T)]$
V_S, VS	Blade section advance speed at 0.7R, $[V_A^2+(0.7R\omega)^2]^{1/2}$
w_T	Taylor Wake Fraction
$\eta_{ALL}, ETAALL$	Total of rotor & support assembly open water efficiency, $[JK_{TALL}/2\pi K_Q]$
η_o	Open Water Efficiency, $[JK_T/2\pi K_Q]$
$\eta_p, ETAP$	Rotor Open Water Efficiency, $[JK_{TP}/2\pi K_Q]$
$\eta_T, ETAT$	Total Open Water Efficiency, $[JK_{TT}/2\pi K_Q]$
λ	Linear Ratio
ρ	Mass Density of Water
v	Kinematic Viscosity of Water
ω	Propeller Angular Velocity, $2\pi n$

ENGLISH TO METRIC CONVERSIONS

1 degree (angle)	=	0.01745 rad (radians)
1 ft (foot)	=	0.3048 m (meters)
1 ft/s (foot per second)	=	0.3048 m/s (meters per second)
1 in (inch)	=	25.40 mm (millimeters)
1 knot	=	0.5144 m/s (meters per second)
1 lbf (pound-force)	=	4.448 N (newton)
1 lbf-in (pound-force-inch)	=	0.1130 N-m (newton-meters)
1 long ton (2240 pounds)	=	1.016 metric tons or 1016 kg (kilograms)
1 hp (horsepower)	=	0.746 kW (kilowatts)

ABSTRACT

An experimental program was conducted at the Carderock Division Naval Surface Warfare Center (NAVSURFWARCEN CARDEROCKDIV) in support of the Advanced Hull Form Inshore Demonstrator (AHFID) ship for the Electric Boat Corporation. The objective of this work was to predict the ahead performance of a ducted propulsor and support struts designed for the AHFID in uniform inflow. Numerical and graphical results are presented. No anomalous performance characteristics were revealed. The total thrust and torque of the propulsor measured in the experiments should give an accurate indication of how the full-scale unit would perform in uniform flow.

ADMINISTRATIVE INFORMATION

The work described herein was authorized and funded by the Electric Boat Corporation, in accordance with Work for Private Party Agreement WPP-54-0194. This investigation was performed at the Carderock Division Naval Surface Warfare Center, by the Hydromechanics Directorate, Propulsion and Fluid Systems Department (Code 5400) and was funded under FY 01 work unit number 1-5400-802.

INTRODUCTION

The experimental evaluation of a model of the propulsor and struts was performed by the Carderock Division Naval Surface Warfare Center (NAVSURFWARCEN CARDEROCKDIV), in support of the Advanced Hull Form Inshore Demonstrator (AHFID) ship for the Electric Boat Corporation. The purpose of this test program was to evaluate the performance of the propulsor and struts in uniform flow in the towing basin. The test program consisted of the following:

- Ahead performance of the propulsor and struts in open water at a constant advance coefficient through a range of Reynolds numbers while operating at a pitch angle of 0 degrees.
- Ahead performance of the propulsor and struts in open water through a range of forward speeds and rotational speeds while operating at a pitch angle of 0 degrees.
- Ahead performance of the propulsor and struts in uniform flow through a range of forward speeds and rotational speeds while operating at a pitch angle of 6.5 degrees above the 0 degree shaft line.
- Bollard pull performance of the propulsor and struts in open water through a range of rotational speeds with no forward speed.
- Oil paint flow visualization to assess the flow over the propulsor and struts at the design condition which was run in the ahead test performed at 0 degrees of pitch.
- Ahead performance of the struts in open water through a range of Reynolds numbers while operating at a pitch angle of 0 degrees.

The purpose of this document is to present representative data from the experimental program and to verify that the results are reasonable.

DESCRIPTION OF PROPELLER

The full-scale AHFID propulsor will be a rim driven post-swirl propulsor. The Pennsylvania State University/Applied Research Laboratory (PSU/ARL) designed the propulsor. Propeller model 5408 represents the right hand rotor with a full-scale tip diameter at the trailing edge of 4.375 ft (1.33 m). The propulsor was manufactured to a scale ratio of 4.375 resulting in a 12.00 inch (30.48 cm) diameter model rotor. The rotor has 7 blades and a chord length at the 0.7 radius of 3.902 inches (9.912 cm). Propeller model 5409 represents post swirl stator portion of the AHFID propulsor and has five blades. Drawings showing the propulsor are presented in Figures 1 and 2.

EXPERIMENTAL SET-UP

Open water experiments were performed with propulsor 5408 and 5409 in the NAVSURFWARCEN CARDEROCKDIV Carriage 2 Towing Basin using the high speed open water apparatus and the arrangement shown in Figures 3 and 4. A Kempf and Remmers Model H 48 dynamometer was used for measuring rotor thrust and torque. The duct was held in proper position by two short strut sections, which attached to the strut axial force gages built by PSU/ARL. The strut force gages were used to measure the axial force on the stator, duct and lower struts, which they supported. An upper strut section supported the top of each strut gage. The upper strut section was bolted to a plate, which was attached to the base of the 6-component gage. The 6-component gage was used to measure the forces and moments on the stator, duct and struts acting at the center of the gage. The 6-component gage center was located 48.704 in. (123.71 cm) above the rotor shaft centerline and 4.265 in. (10.83 cm) back from the rotor blade reference line (see Figure 3). A high capacity 6-component gage was required because it had to be strong enough to support the weight of the stator, duct and struts, as well as measure the high moments produced by the propulsor. The unit was mounted forward of the high speed open water apparatus in order to achieve uniform flow into the propulsor. The depth of submergence to the shaft centerline of the model was 35.70 inches (90.68 cm), which was chosen to match full-scale waterline of 13.01 feet (3.97 m).

The design gap clearance between the band of the rotor and the duct was 0.040 inch (1.02 mm) on all sides. Maintaining this clearance while operating during the tests was a concern. If the gap were to close the hardware could be damaged and the measurements spoiled. In order to prevent damage and save the measurements a thrust bearing was incorporated into the design (Figure 2, Part 13). This thrust bearing rotated with the shaft and had a clearance of 0.030 inches (0.762 mm) on the forward and aft side of the stationary stator hub. The stator hub could move forward and aft by less than 0.030 inch with no interference. If the stator hub were to move 0.030 inches or greater in either direction the stator would ride on the bearing. This would leave the rotor torque measurement unchanged and the portion of the duct stator axial force not measured by the strut gages would be measured by the rotor dynamometer thereby preserving the unit thrust measurements.

Early in the test program, it was discovered that above a specific drag load the support system deflected enough to cause the gap between the rotating rotor band and stationary stator to close causing light rubbing at the bottom of the unit. The experiments were performed while monitoring the loads on the strut gages, keeping them below the limits, which would cause the rotor band/duct gap to close. The propulsor was disassembled and the gap clearances were checked for rubbing at the conclusion of each experiment to assure the integrity of the measurements.

EXPERIMENTAL PROCEDURES

Instrumentation details including measurement accuracies and repeatabilities are described in Appendix A.

Bollard Pull

Bollard pull data were acquired with Carriage 2 stopped and positioned in the middle of the Towing Basin. Shaft rotational speed was increased in increments and held constant. Steady state data were acquired for each steady rps until the load measured was close to the axial force limit of the strut gages or the torque limit of the rotor dynamometer.

Reynolds Number Variation

Experimental conditions were established by setting the propeller rotational speed and carriage speed to achieve the design propeller advance coefficient (J) of 1.85. The data were collected in steady state conditions, i. e.; each datum point was obtained at a constant carriage speed and rotational speed. Carriage speed was varied between 2 (0.61 m/s) and 20 ft/sec (6.10 m/s) over a range of shaft speeds which were set to maintain an advance coefficient of 1.85.

Open Water

Separate tests were performed with the propulsor at a pitch angle of 0 and upward pitch angle of 6.5 degrees. Experimental conditions were established by setting the propeller rotational speed and carriage speed to achieve specific advance coefficients. The data were collected in steady state conditions, i. e.; each datum point was obtained at a constant carriage speed and rotational speed. Carriage speed was varied between 0 and 16 ft/sec (4.88 m/s) over a range of shaft speeds that did not exceed the strut loading limits that would cause the rotor/hub gap to close. Once the maximum carriage speed of 16 ft/sec (4.88 m/s) and rotational speed of 8.64 rps was achieved the rotational speed was incrementally decreased to a minimum value of 0.16 rps.

Initial tests were attempted with a maximum speed of 20 ft/sec (6.10 m/s) at a pitch angle of 0 degrees. It was discovered that above a specific drag load the support system deflected enough to cause the gap between the rotating rotor band and stationary stator to close causing light rubbing at the bottom of the unit (see Figure 5). The maximum speed was reduced to 16 ft/sec (4.88 m/s) which was low enough to prevent the rotor band/duct gap from closing.

Photographs of the strut spray and waves were taken during the experiment performed at 0 degrees of pitch.

Oil Paint Flow Visualization

Mixtures of oil and artist paint pigments in various colors were applied to the propulsor and struts. Paint flow patterns were evaluated at a 0 degree pitch angle. The shaft centerline of the propulsor was submerged a depth of 35.70 inches (90.68 cm) which was used in the open water test. The carriage was accelerated up to a propeller advance speed (V_A) of 16 ft/sec (4.88 m/s) and rotational speed of 8.64 rps and kept at this steady condition for the remainder of the length of the basin (about 70 seconds). This is the same test condition, a J value of 1.85 and effective advance angle (β^*) of 0.70, which was run during the open water experiments. The carriage was stopped and the propulsor was lifted out of the water. The resulting paint flow patterns were photographed.

Strut Forces

The strut force test was the final test to be performed in the test program. The propulsor was removed from the strut gages by unbolting each strut at the base of the gage. The duct and lower struts were replaced by short strut end fairings (see Figure 6). Experimental conditions were established by setting a steady carriage speed. Strut drag data were collected in steady state conditions, i. e., each datum point was obtained at a constant carriage speed. Carriage speeds were varied between 0 and 20 ft/sec (6.10 m/s).

PRESENTATION OF RESULTS

Bollard Pull

Bollard pull data are presented in the form of nondimensional coefficients of rotor thrust (K_{TP}), duct/stator thrust (K_{TD}), and total thrust ($K_{TT} = K_{TP} + K_{TD}$) and rotor torque (K_Q) as a function of the Reynolds number computed at the 70% chord length of the rotor blade. Bollard pull data are also presented in the form of non-dimensional coefficients of rotor thrust index (C_{TP*}), duct/stator thrust index (C_{TD*}), total thrust index ($C_{TT*} = C_{TP*} + C_{TD*}$) and rotor torque index (C_{Q*}) as a function of the Reynolds number computed at the 70% chord length of the rotor blade. The bollard pull data are presented in Figures 7 and 8 and Table 1.

The C_{Q*} and C_{TT*} coefficients level off at Reynolds numbers higher than about 1.7×10^5 . The thrust force split between the rotor and duct appears to reach a constant level between the Reynolds numbers of 1.63 and 3.26×10^5 . At values of Reynolds numbers higher than 3.26×10^5 the rotor thrust decreases and the duct thrust increases. The strut drag measured at the Reynolds number of 3.26×10^5 was about 50 lbf (222.40 N). It was learned later in the test program that strut gage readings exceeding a total of 50 lbf could cause thrust bearing contact altering the rotor duct force split. It is recommended that the coefficient values recorded at the Reynolds number of 3.26×10^5 be used when estimating bollard pull performance of the propulsor at higher Reynolds numbers.

Reynolds Number Variation

The data are presented in the form of nondimensional coefficients of rotor thrust (K_{TP}), duct/stator thrust (K_{TD}), and total thrust ($K_{TT} = K_{TP} + K_{TD}$) and rotor torque (K_Q) as a function of the Reynolds number computed at the 70% chord length of the rotor blade. Data are also presented in the form of non-dimensional coefficients of rotor thrust index (C_{TP*}), duct/stator thrust index (C_{TD*}), total thrust index ($C_{TT*} = C_{TP*} + C_{TD*}$) and rotor torque index (C_{Q*}) as a function of the Reynolds number computed at the 70% chord length of the rotor blade. The data are presented in Figures 9 and 10 and Table 2.

The coefficients level off at Reynolds numbers higher than about 3.22×10^5 . At values of Reynolds numbers higher than 8.74×10^5 the rotor thrust decreases and the duct thrust increases. The strut drag measured at the Reynolds numbers of 8.739×10^5 was about 50 lbf (222.40 N). These results show that a strut drag exceeding a total of 50 lbf (222.40 N) probably caused thrust bearing contact altering the rotor duct force split. It was determined that the open water tests would be performed at a maximum speed of 16 ft/sec (4.88 m/s) to avoid the possibility of stator hub contact with the thrust bearing. This results in a Reynolds number of 6.44×10^5 , well into the range where the coefficients are constant.

Open Water

Open water experiments were performed at 0 and 6.5 degrees of pitch. The data are presented in the form of nondimensional coefficients of rotor thrust index (C_{TP*}), total thrust index measured on the rotor and duct/stator ($C_{TT*} = C_{TP*} + C_{TD*}$), thrust index measured on all components including the rotor and strut/duct/stator ($C_{TALL*} = C_{TP*} + C_{FX}$), and rotor torque index (C_{Q*}), as a function of effective advance angle (β^*). Forces and moments measured on the strut/duct/stator assembly with the 6-component dynamometer are presented as non-dimensional force and moment index coefficients C_{FX} , C_{FY} , C_{FZ} , C_{MX} , C_{MY} and C_{MZ} . The experimental data points were faired using a least squares curve fit. C_{TP*} , C_{TT*} , C_{TALL*} , C_{Q*} , C_{FX} , C_{FY} , C_{FZ} , C_{MX} ,

$C_{MY}/10$ and C_{MZ} were faired independently against β^* . The resulting polynomial coefficients were used to produce tabulated coefficients and the faired curves shown in the plots. Data are also presented in the form of nondimensional coefficients of rotor thrust (K_{TP}), total thrust ($K_{TT} = K_{TP} + K_{TD}$), rotor torque (K_Q) as a function of propeller advance coefficient (J). Rotor thrust loading coefficients (C_{TP}), total thrust loading coefficient of the duct/stator and rotor (C_{TT}), rotor torque loading coefficient, (C_Q) are presented in tables as a function of effective advance angle (β^*).

Figures 11 – 16 and Tables 3 - 5 present the results of the open water experiments conducted with propulsor 5408 & 5409 at the 0 degrees of pitch angle. Figures 17 – 22 and Tables 6 - 8 present the results of the open water experiments conducted with propulsor 5408 & 5409 at the 6.5 degrees of pitch angle. The figures show both the experimental data points and the faired curves. The tables contain values based on the faired curves shown in the figures.

Faired performance data at the 0 and 6.5 degree pitch conditions for $J = 1.85$ are presented in Table 9. The performance at 0 and 6.5 degrees was similar showing that the performance of this propulsor is not influenced by a small inflow angle, as expected for a ducted unit.

The thrust contributions of the various propulsor components are also shown in Table 9. The propulsor produced 83.3% of the rotor thrust; therefore, the drag of the stators/duct reduced the thrust produced by the rotor by 16.7%. The differential pressures in the gap between the rotor band and the recess in the duct can have a significant effect on the thrust measured on each component of the propulsor. The differential pressures in the gap increase rotor thrust and increase duct drag by the same amount so unit thrust is not effected. Michael presented propulsor performance predictions and an estimate of the gap pressure effect on rotor and duct thrust forces [Reference 1].

Photographs taken of the strut spray and waves at various carriage speeds at the 0-degree pitch condition are presented in Appendix B.

Oil Paint Flow Visualization

The oil paint flow patterns were photographed at the 0 degree pitch condition and are presented in Appendix C.

Strut Forces

Strut force experiments were performed at 0 degrees of pitch. Strut drag data are presented as physical units for the axial force (F_x) measured on the 6-component gage and the total of the drag measured on the portion of each strut below the strut gages ($T_{DS} + T_{DP}$) as a function of model speed (carriage speed). The physical unit data and faired values are presented in Figure 23 and Table 10.

Strut drag data are presented as an axial force index coefficient (C_{FX}) measured on the 6-component gage and as an index coefficient of the total of the drag measured on the portion of the struts below the strut gages (C_{TD^*}) as a function of model speed (carriage speed). Test coefficient data are presented in Figures 24 and Table 11.

CONCLUSIONS

Examination of the open water data for model propulsor 5408 and 5409 disclosed that the performance of the unit was about the same at pitch angles of 0° and 6.5° . The total thrust and torque of the propulsor measured in the experiments should give an accurate indication of how the full-scale unit would perform in uniform flow. The pressures produced in the gap between the band and the groove in the duct depend on the gap distances, which may have influenced the thrust/drag measured on the rotor and duct/stator. Consequently, the thrust force measured on the rotor and the drag force measured on the duct/stator may not give a true indication of the actual full-scale forces that would be produced by each component.

This page was intentionally left blank.

AHFID (8/13/2001)

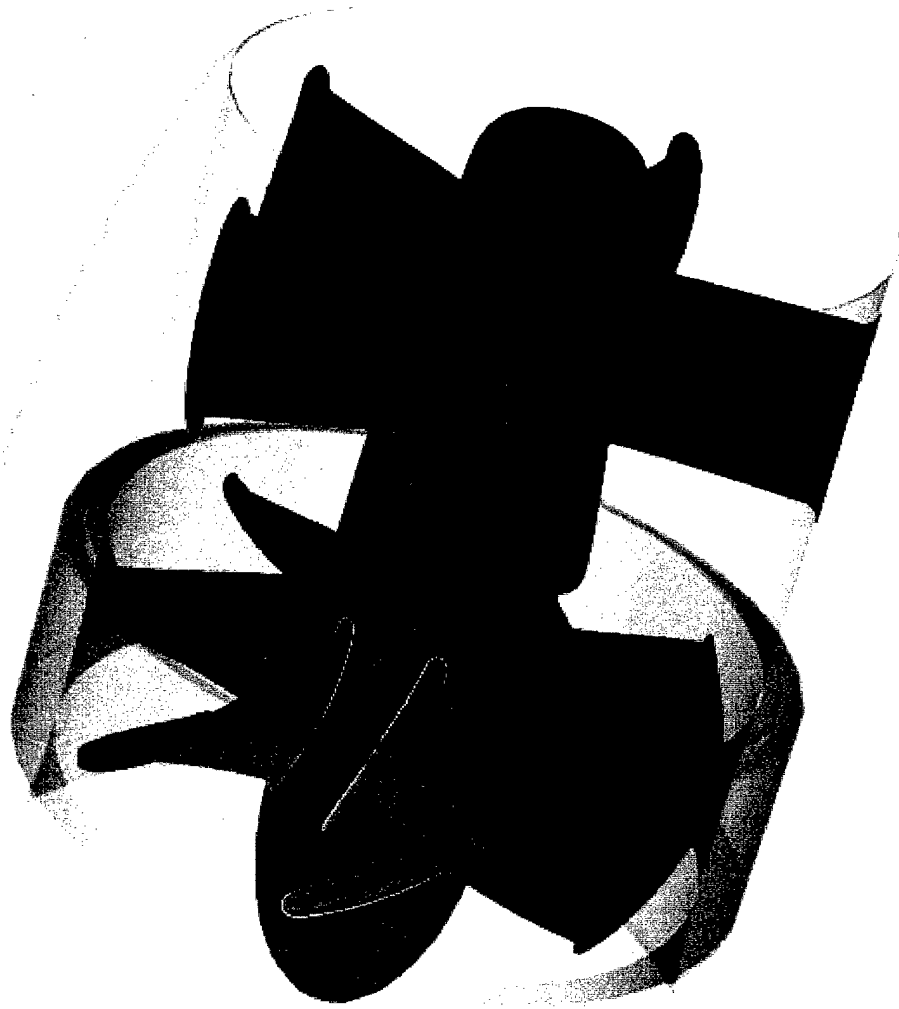
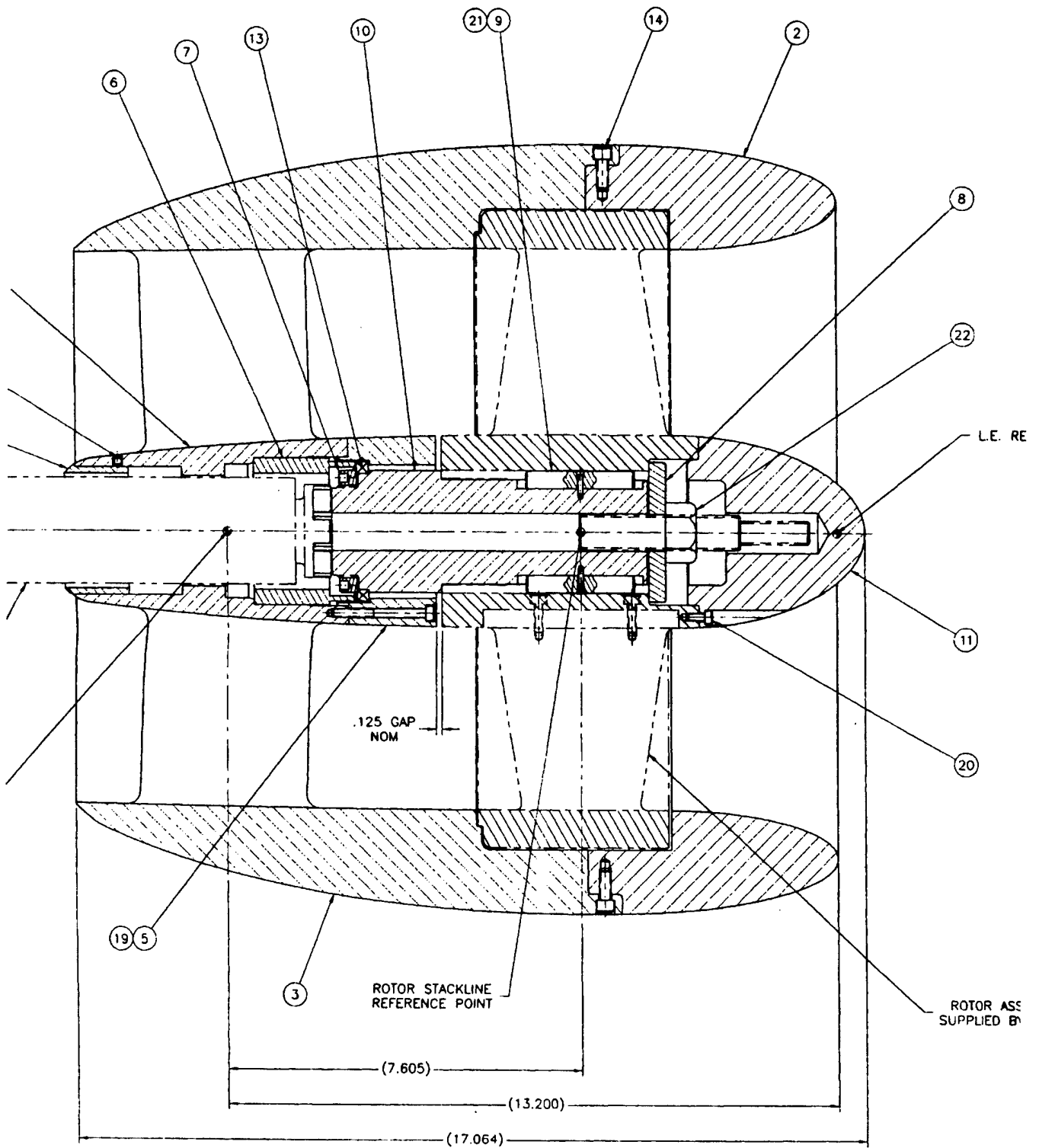
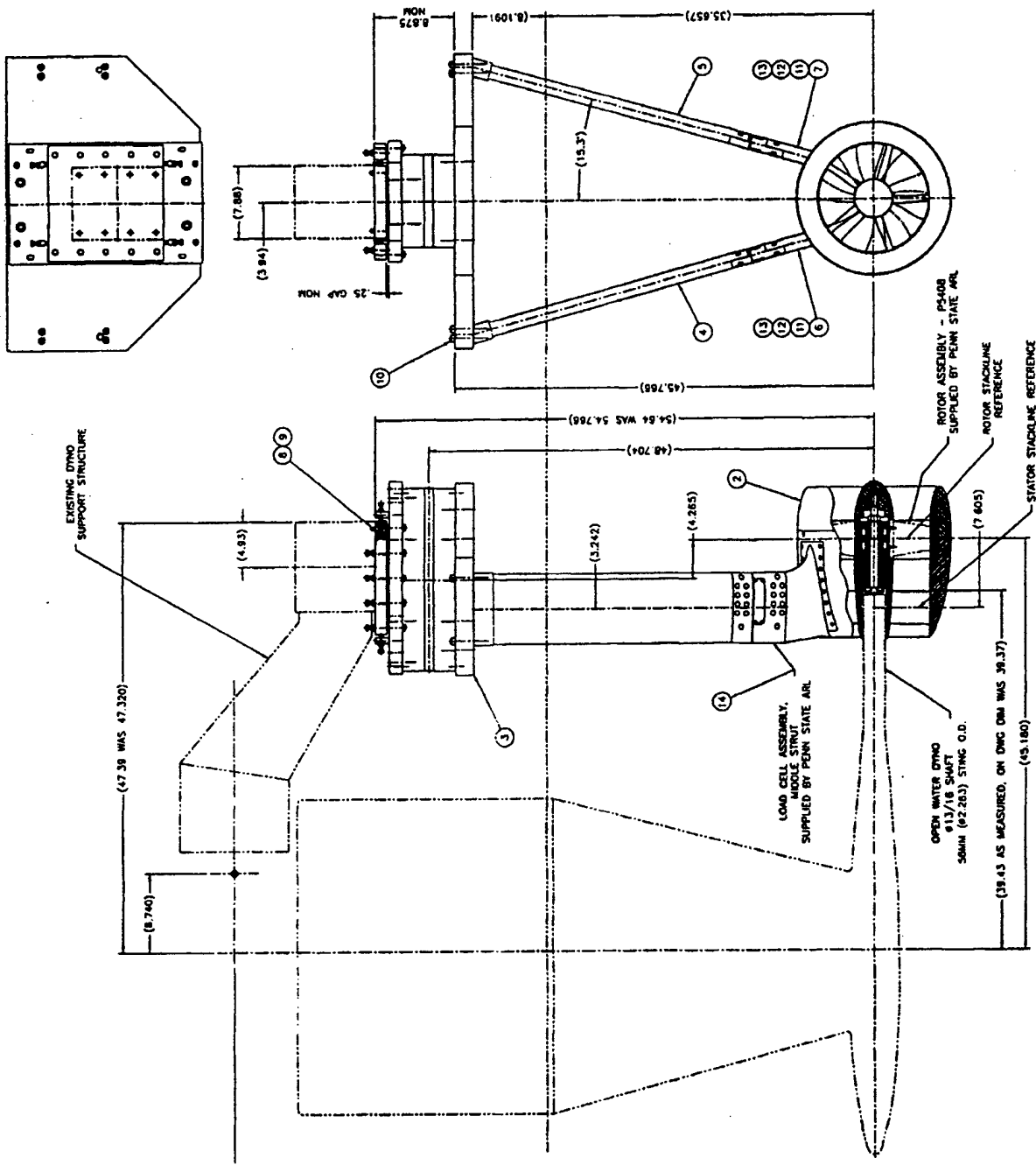

Figure 1. Sketch of the AHFID Propulsor



① PROPULSOR ASSEMBLY
1 REQUIRED

Figure 2. Drawing of the Model Propulsor Assembly



① ADED. - GENERAL ARRANGEMENT

Figure 3. Drawing of the Test Set-up

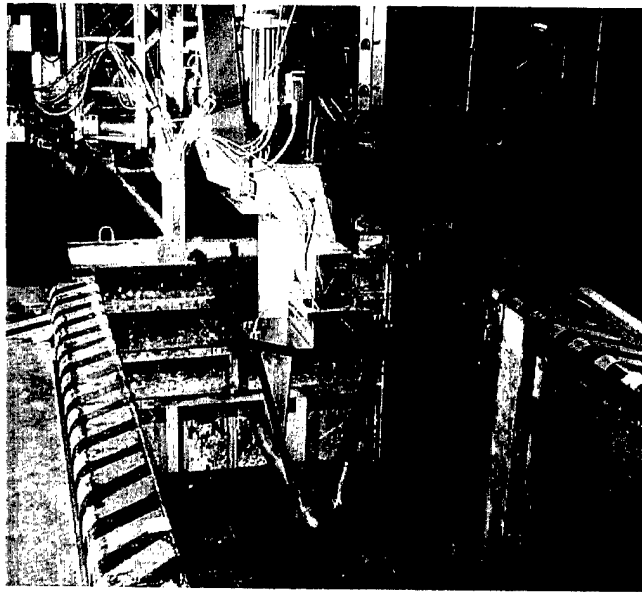

Figure 4. Photographs of the Test Set-up

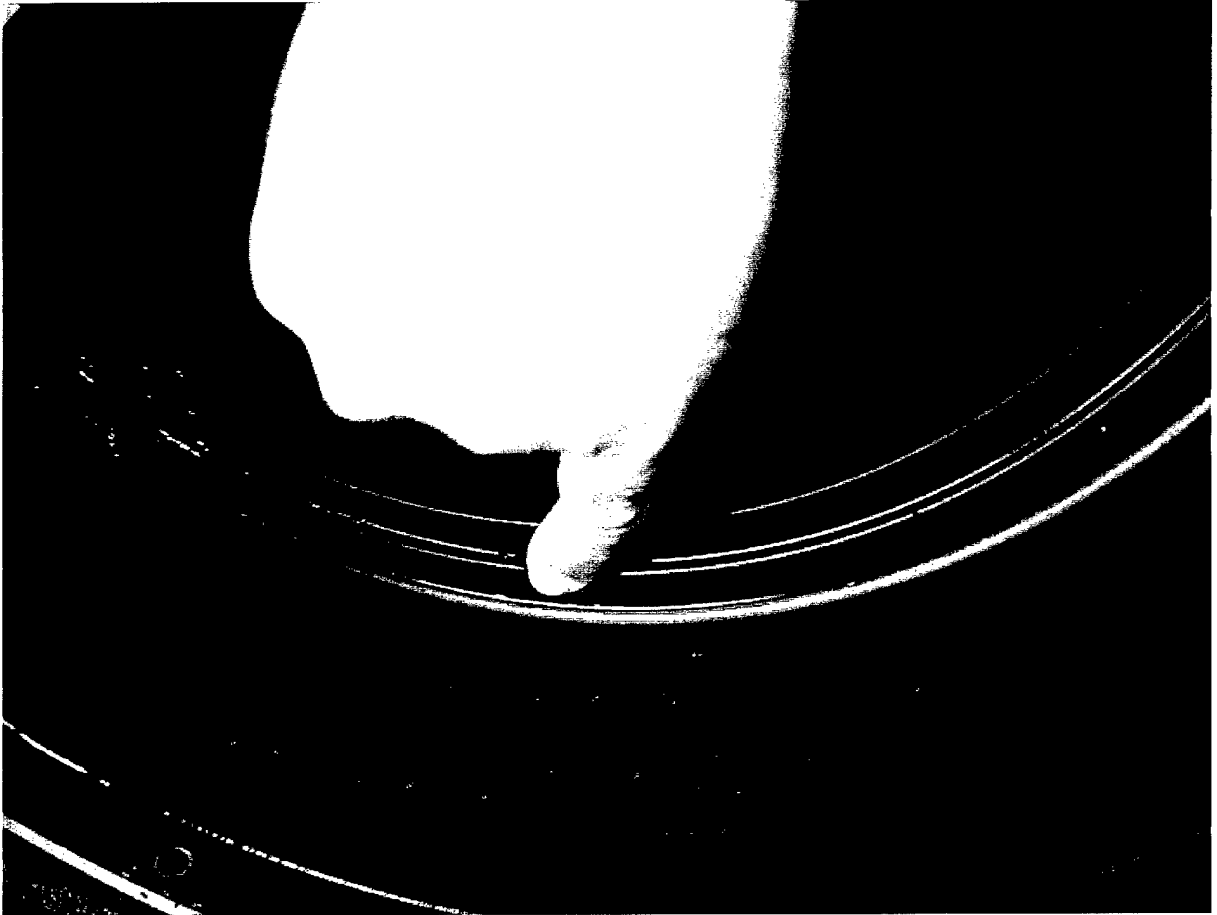

Figure 5. Photograph Showing the Light Rubbing on the Model

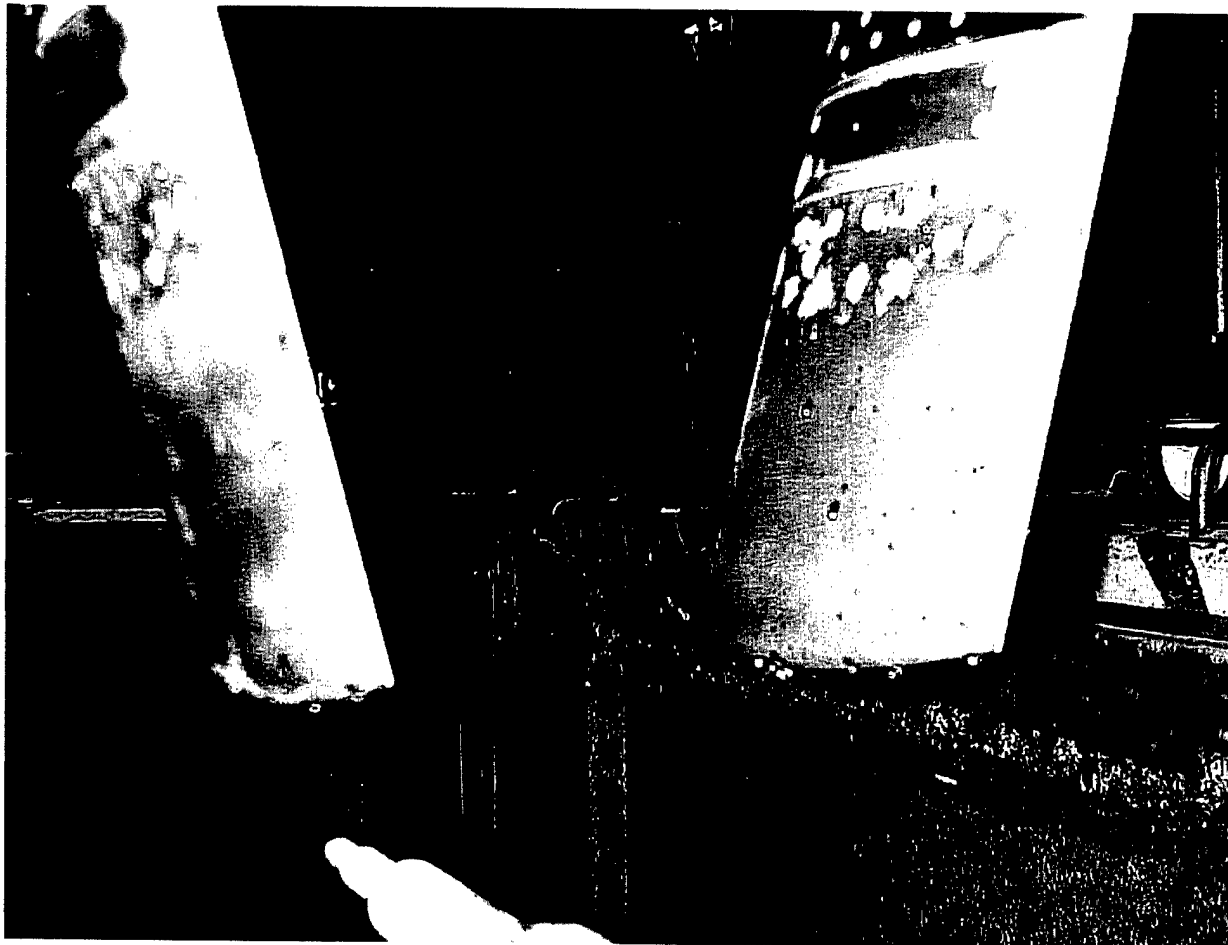

Figure 6. Photographs of the Strut Fairing End Caps

BOLLARD EXPERIMENT - NSWCDD TOWING BASIN CARRIAGE 2
 NOVEMBER 2001 - STRUT W/PROPULSOR 5408/5409 - EXP. 12

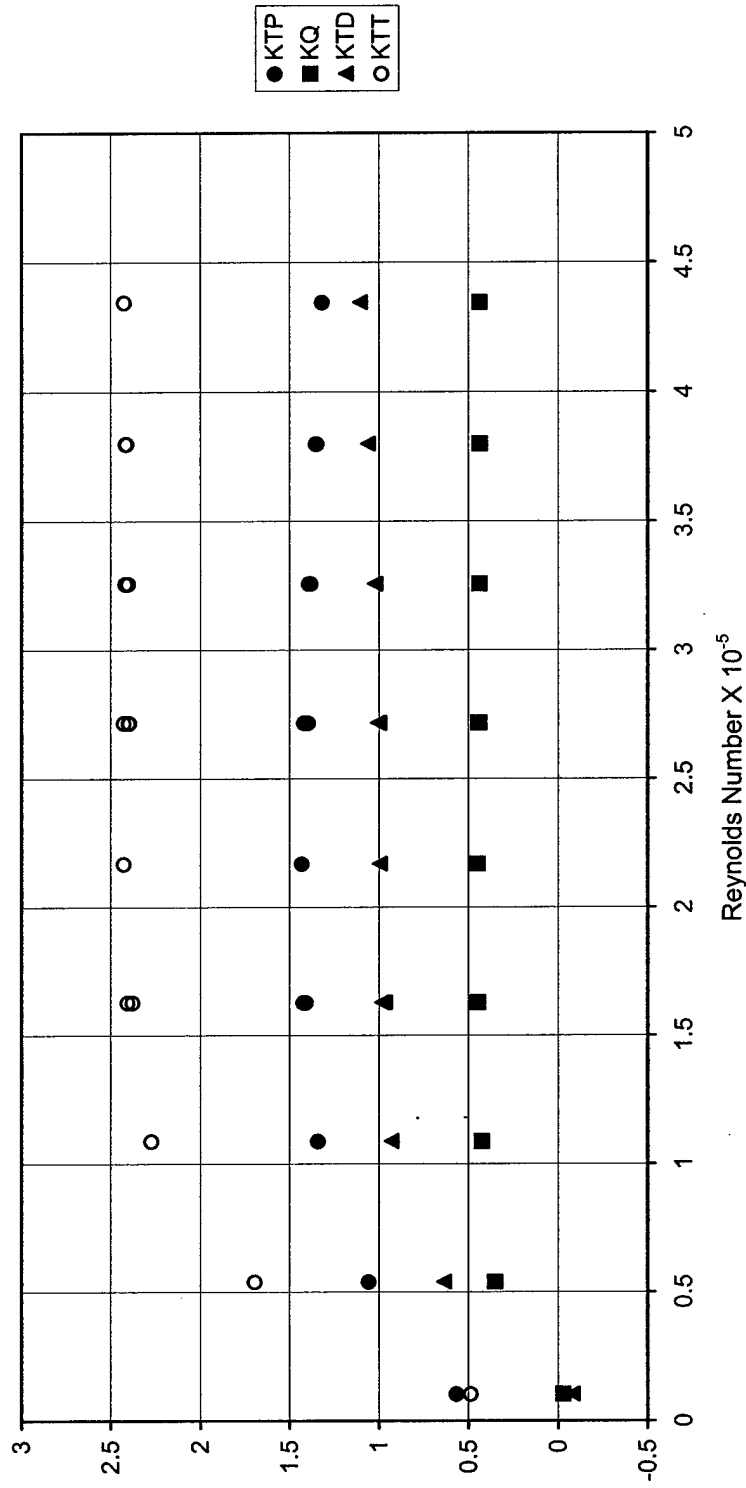

Figure 7. Bollard Pull Data at 0° of Pitch Presented as Thrust & Torque Coefficients

BOLLARD EXPERIMENT - NSWCCD TOWING BASIN CARRIAGE 2
 NOVEMBER 2001 - STRUT w/PROPULSOR 5408/5409 - EXP. 12

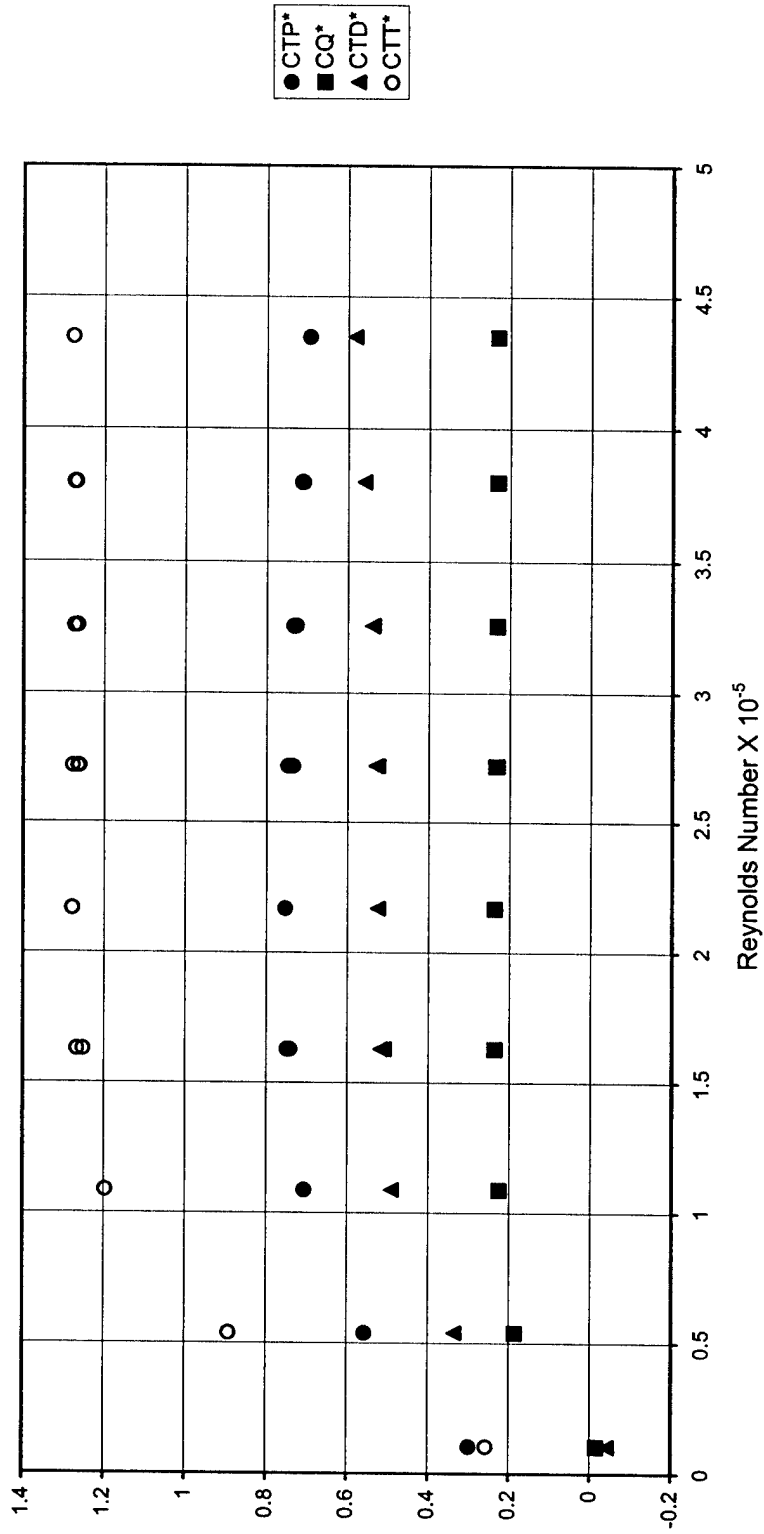

Figure 8. Bollard Pull Data at 0° of Pitch Presented as Thrust & Torque Indexes

REYNOLDS NUMBER VARIATION EXPERIMENT - NSWCCD TOWING BASIN CARRIAGE 2
 NOVEMBER 2001 - STRUT w/PROPULSOR 5408/5409 - EXP. 15

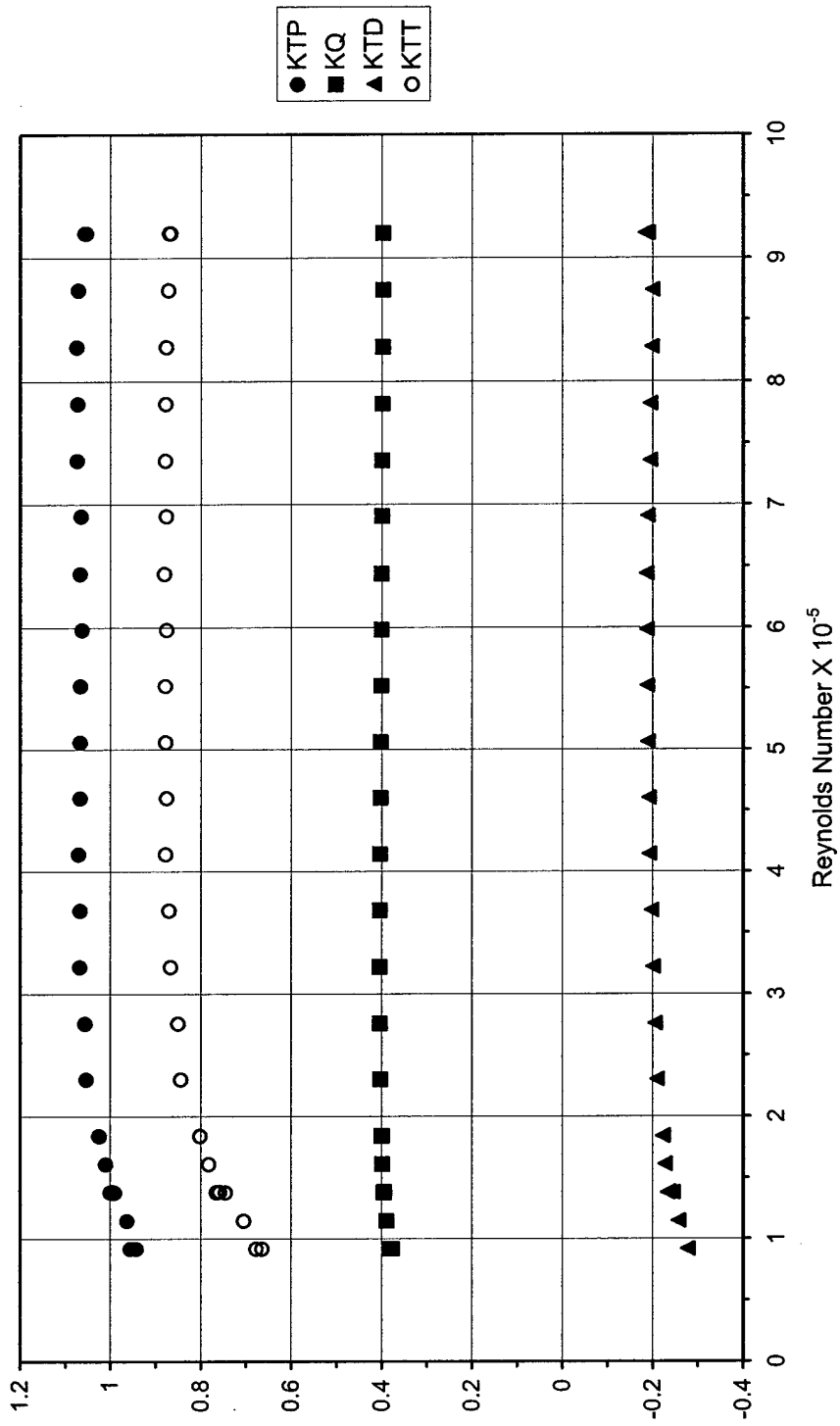

Figure 9. Reynolds Number Variation Data at 0° of Pitch Presented as Thrust & Torque Coefficients

REYNOLDS NUMBER VARIATION - NSWCCD TOWING BASIN CARRIAGE 2
 NOVEMBER 2001 - STRUT w/PROPULSOR 5408/5409 - EXP. 15

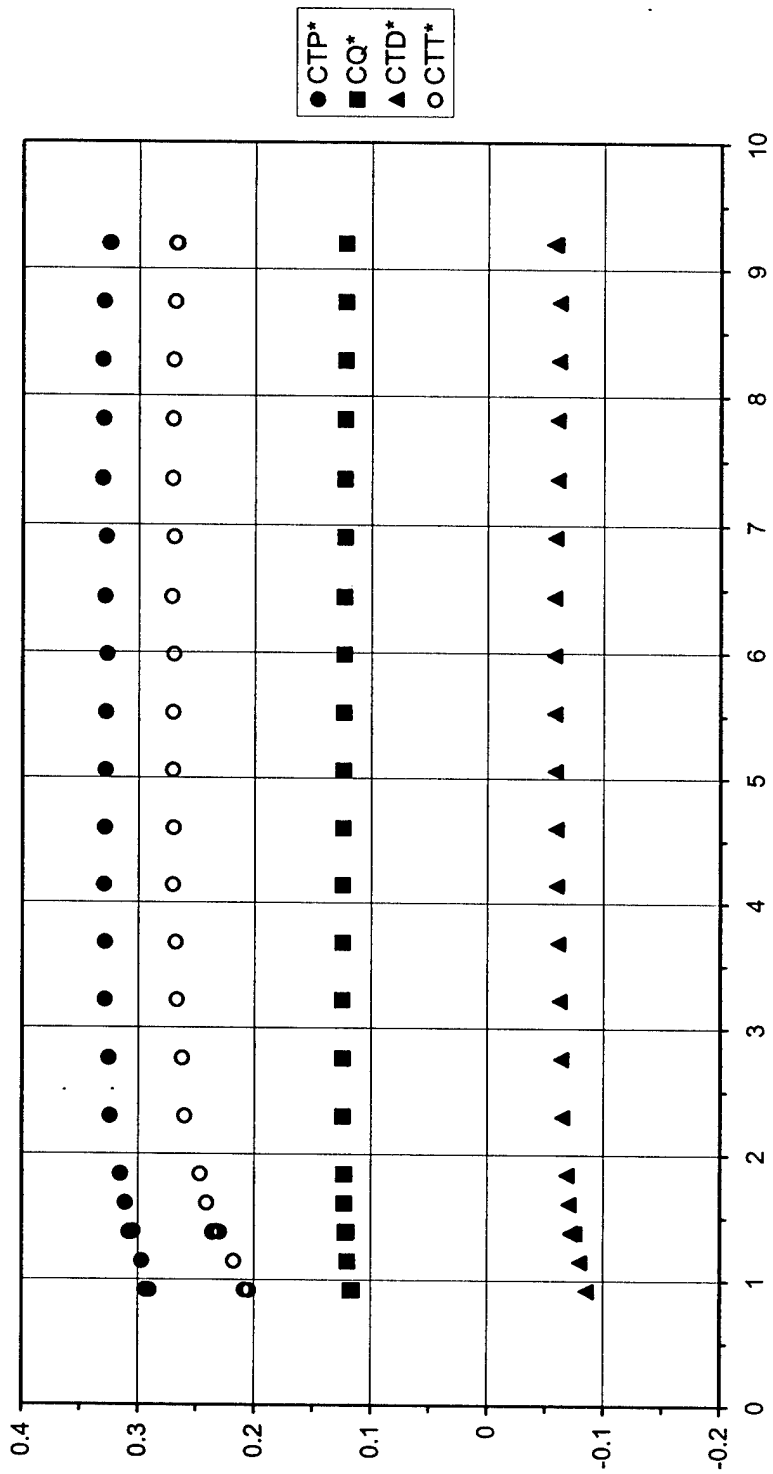

Figure 10. Reynolds Number Variation Data at 0° of Pitch Presented as Thrust & Torque Indexes

AHEAD OPEN WATER EXPERIMENT @ 0° PITCH - NSWCCD TOWING BASIN CARRIAGE 2
 NOVEMBER 2001 - STRUT w/PROPULSOR 5408/5409 - EXP. 16

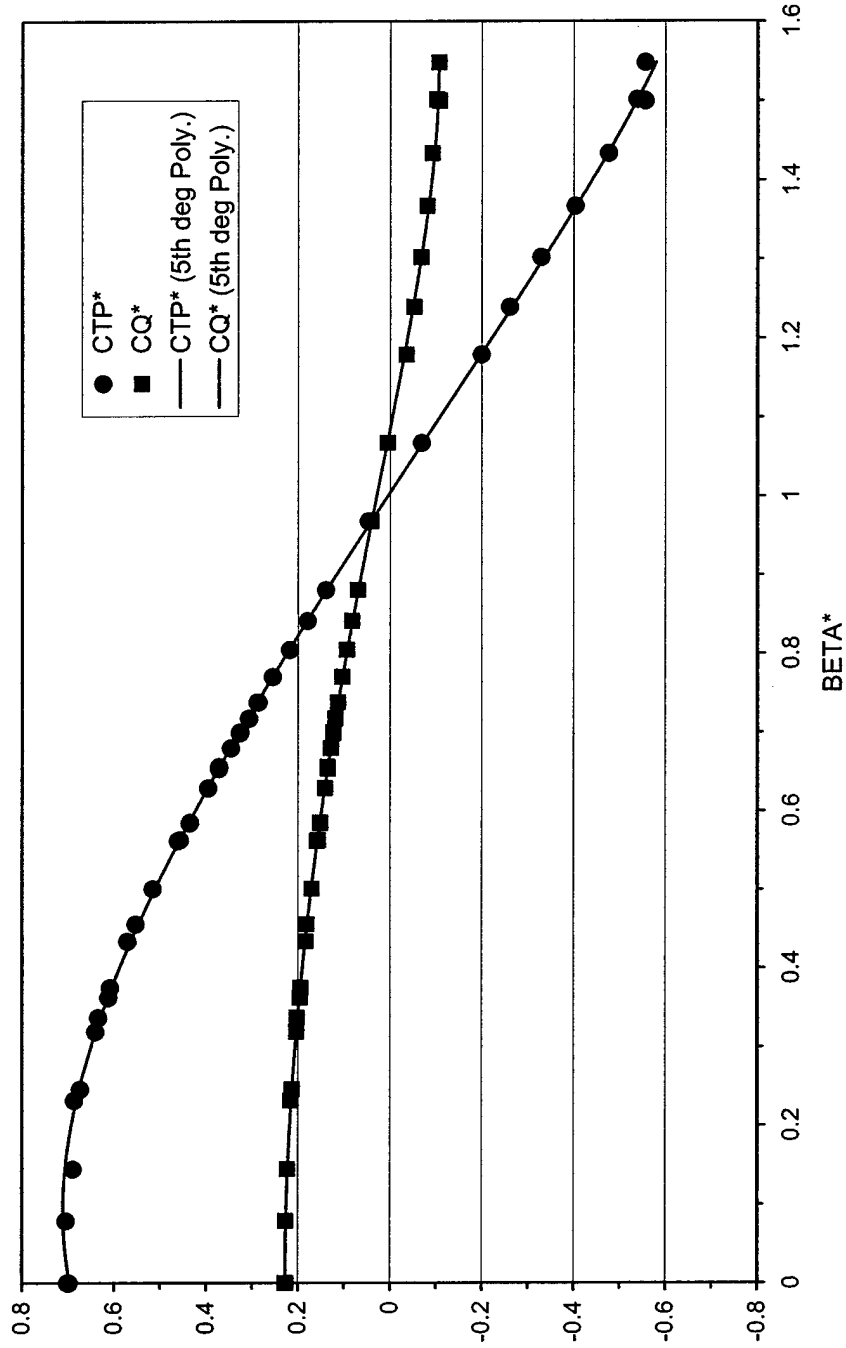

Figure 11. Open Water Rotor Performance Data at 0° of Pitch

AHEAD OPEN WATER EXPERIMENT @ 0° PITCH - NSWCCD TOWING BASIN CARRIAGE 2
 NOVEMBER 2001 - STRUT w/PROPULSOR 5408/5409 - EXP. 16

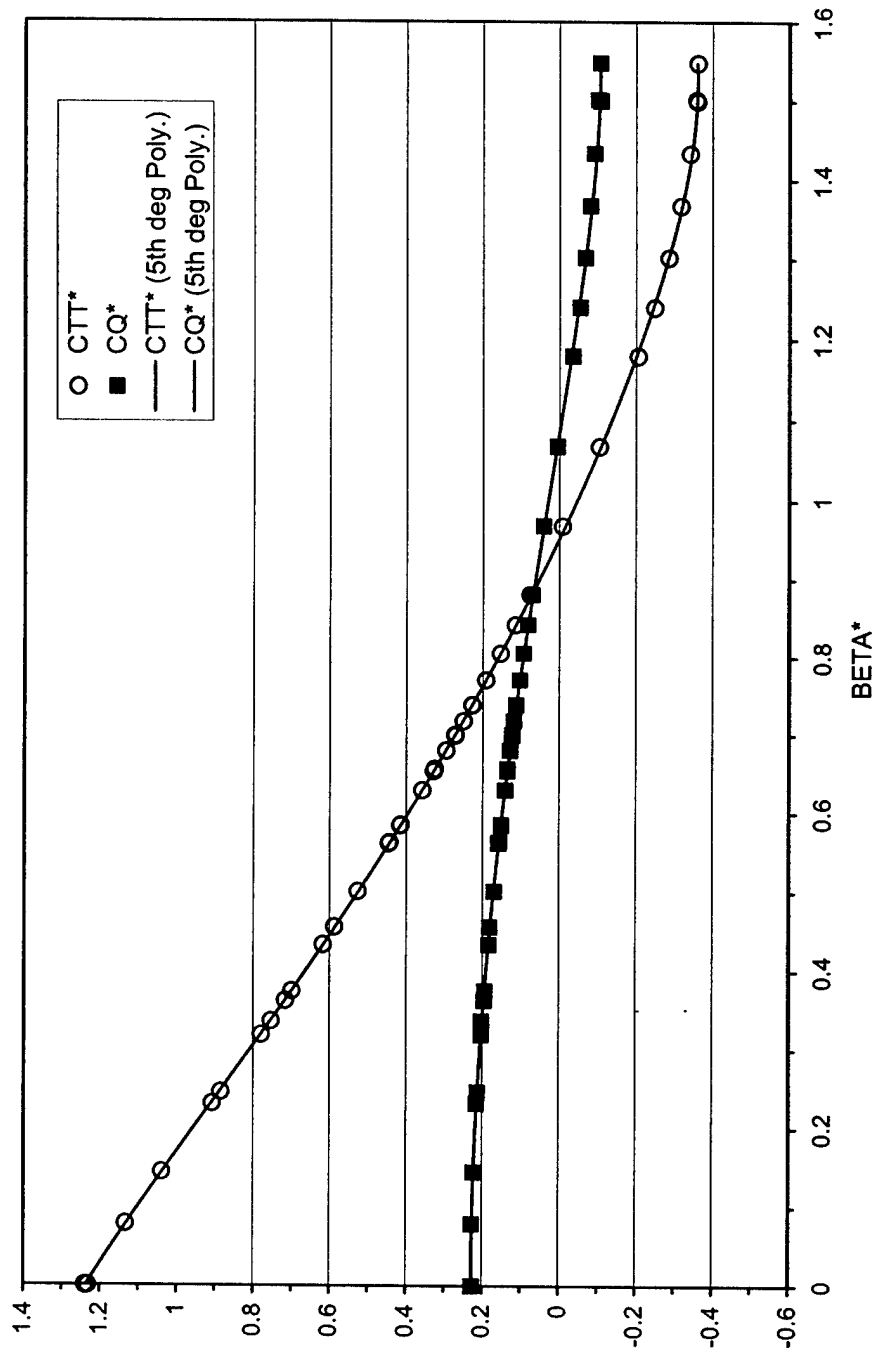

Figure 12. Open Water Propulsor Performance Data at 0° of Pitch

AHEAD OPEN WATER EXPERIMENT @ 0° PITCH - NSWCCD TOWING BASIN CARRIAGE 2
 NOVEMBER 2001 - STRUT w/PROPULSOR 5408/5409 - EXP. 16

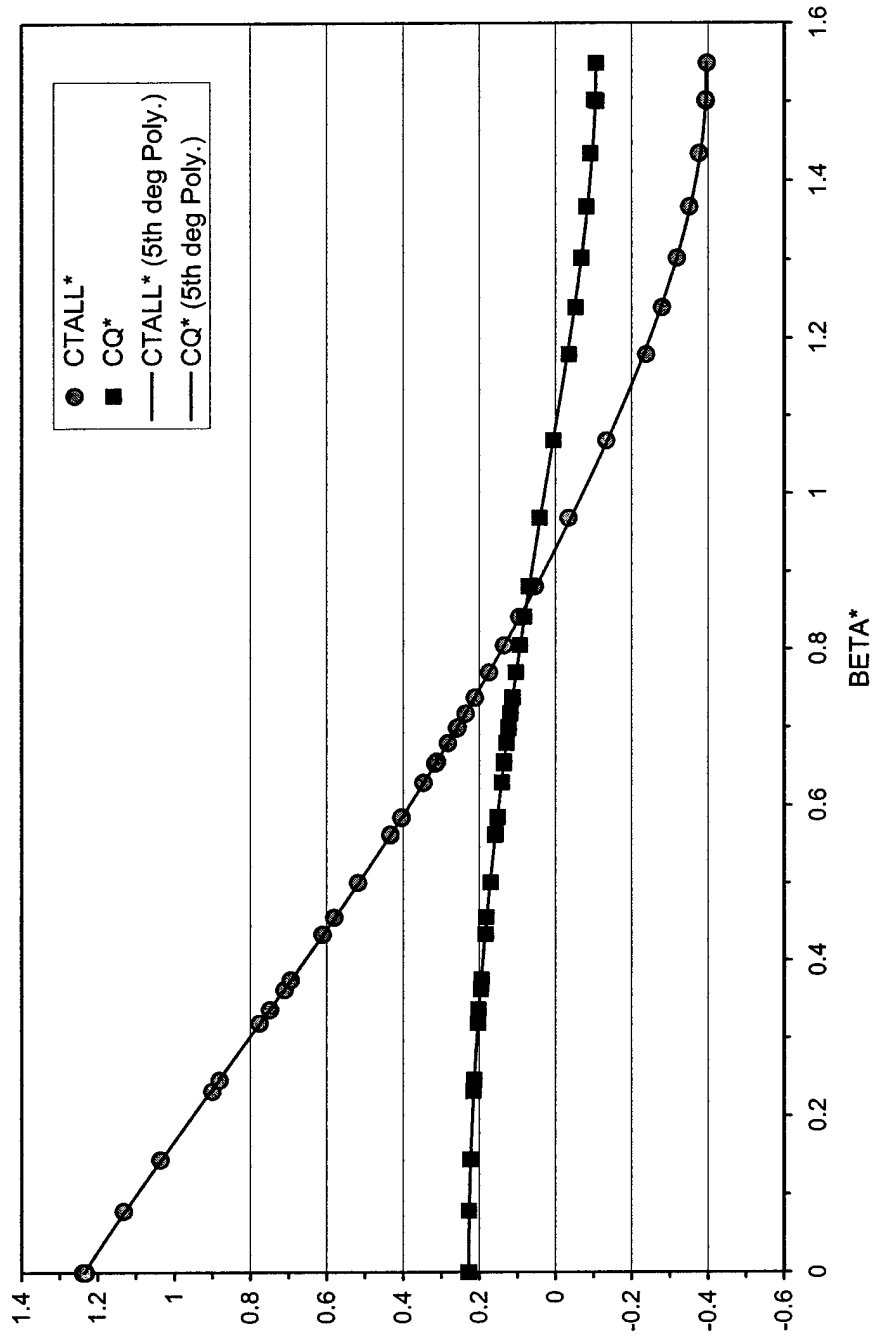

Figure 13. Open Water Propulsor and Strut Assembly Performance Data at 0° of Pitch

AHEAD OPEN WATER EXPERIMENT @ 0° PITCH - NSWCCD TOWING BASIN CARRIAGE 2
 NOVEMBER 2001 - STRUT w/PROPULSOR 5408/5409 - EXP.16

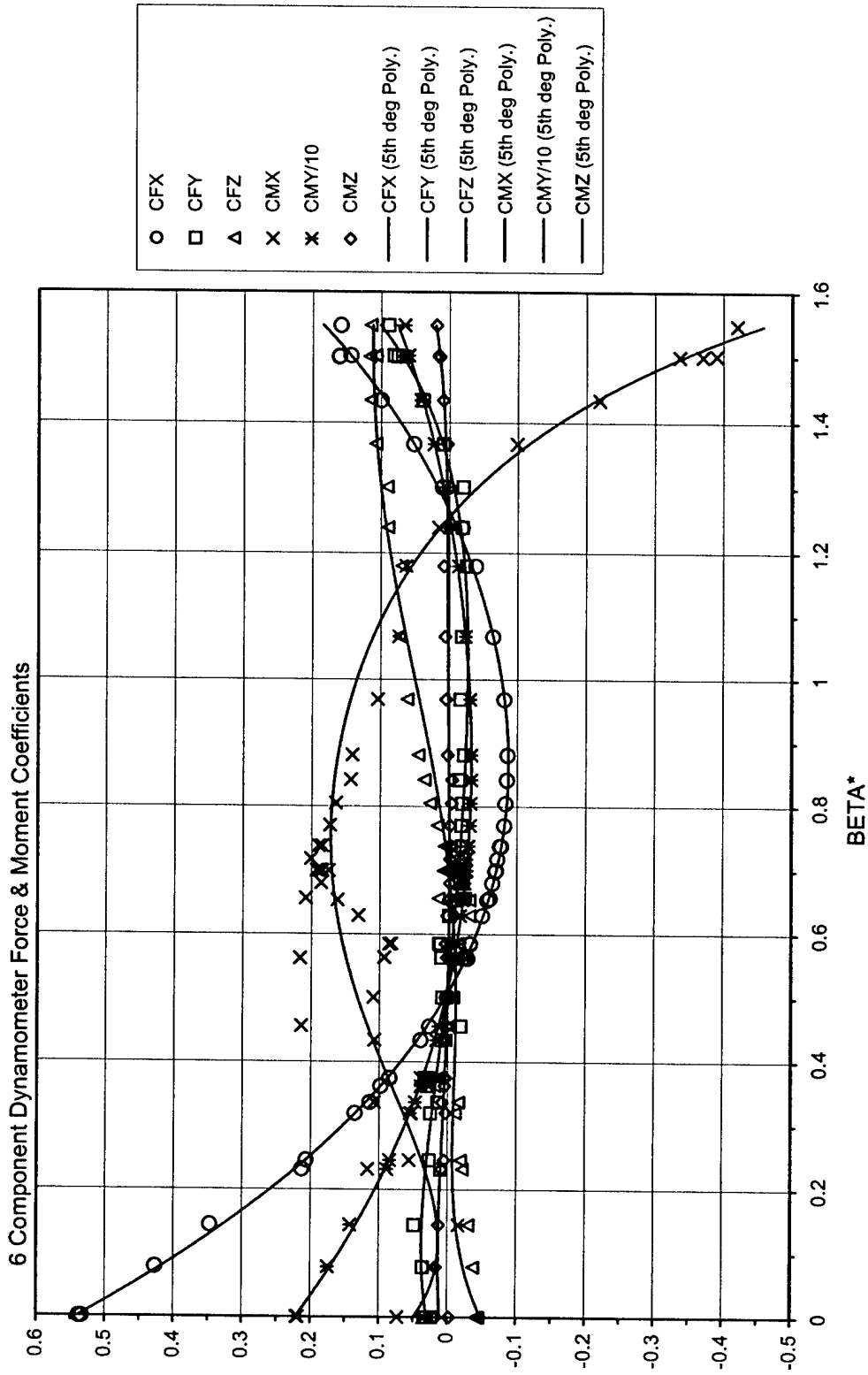

Figure 14. Open Water Duct and Strut Assembly Performance Data at 0° of Pitch

AHEAD OPEN WATER EXPERIMENT @ 0° PITCH - NSWCCD TOWING BASIN CARRIAGE 2
 NOVEMBER 2001 - STRUT w/PROPULSOR 5408/5409 - EXP. 16

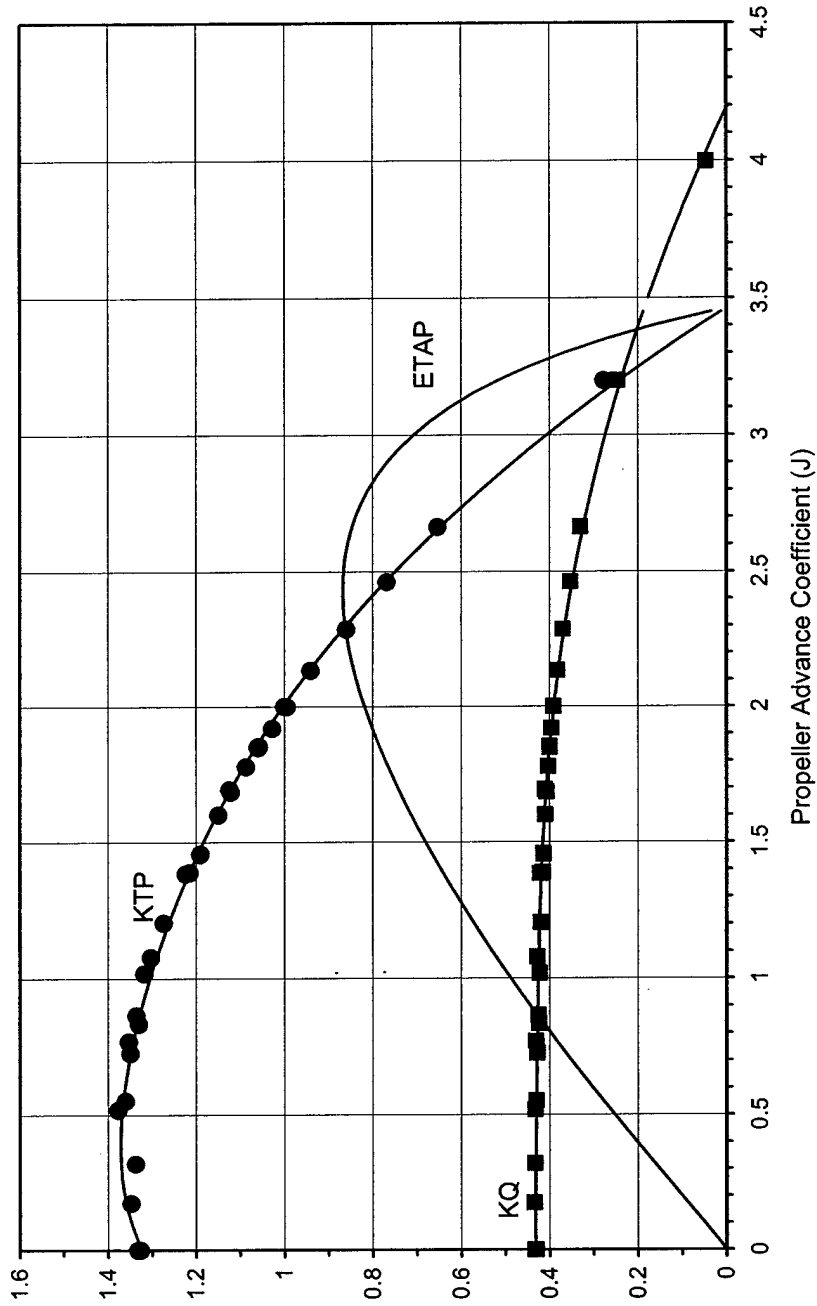

Figure 15. Open Water Rotor Performance Data at 0° Pitch; KTP, KQ, and ETAP

AHEAD OPEN WATER EXPERIMENT @ 0° PITCH - NSWCCD TOWING BASIN CARRIAGE 2
 NOVEMBER 2001 - STRUT w/PROPULSOR 5408/5409 - EXP. 16

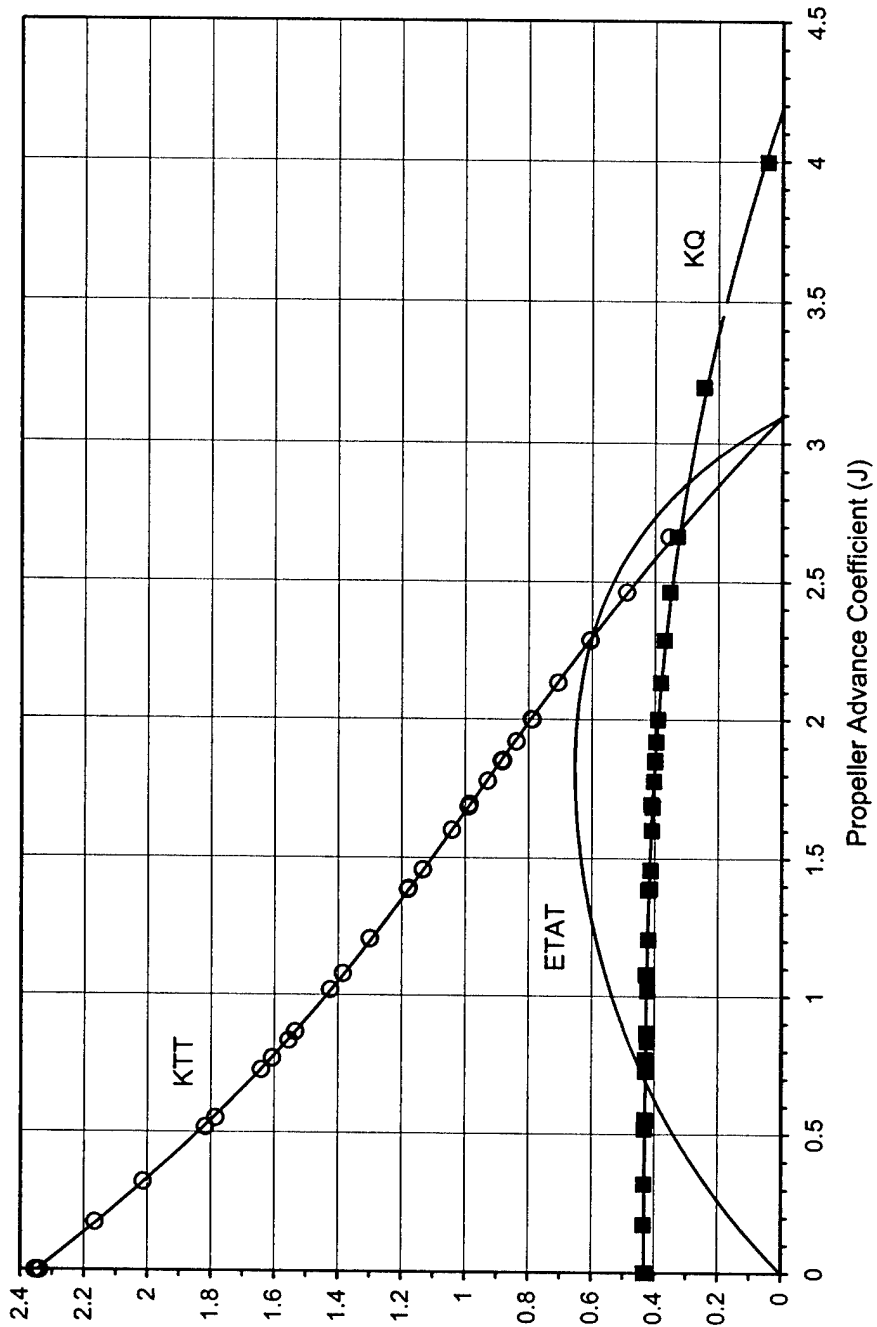

Figure 16. Open Water Propulsor Performance Data at 0° of Pitch; KTT, KQ, and ETAT

AHEAD OPEN WATER EXPERIMENT @ 6.5° PITCH - NSWCCD TOWING BASIN CARRIAGE 2
 NOVEMBER 2001 - STRUT w/PROPULSOR 5408/5409 - EXP. 18

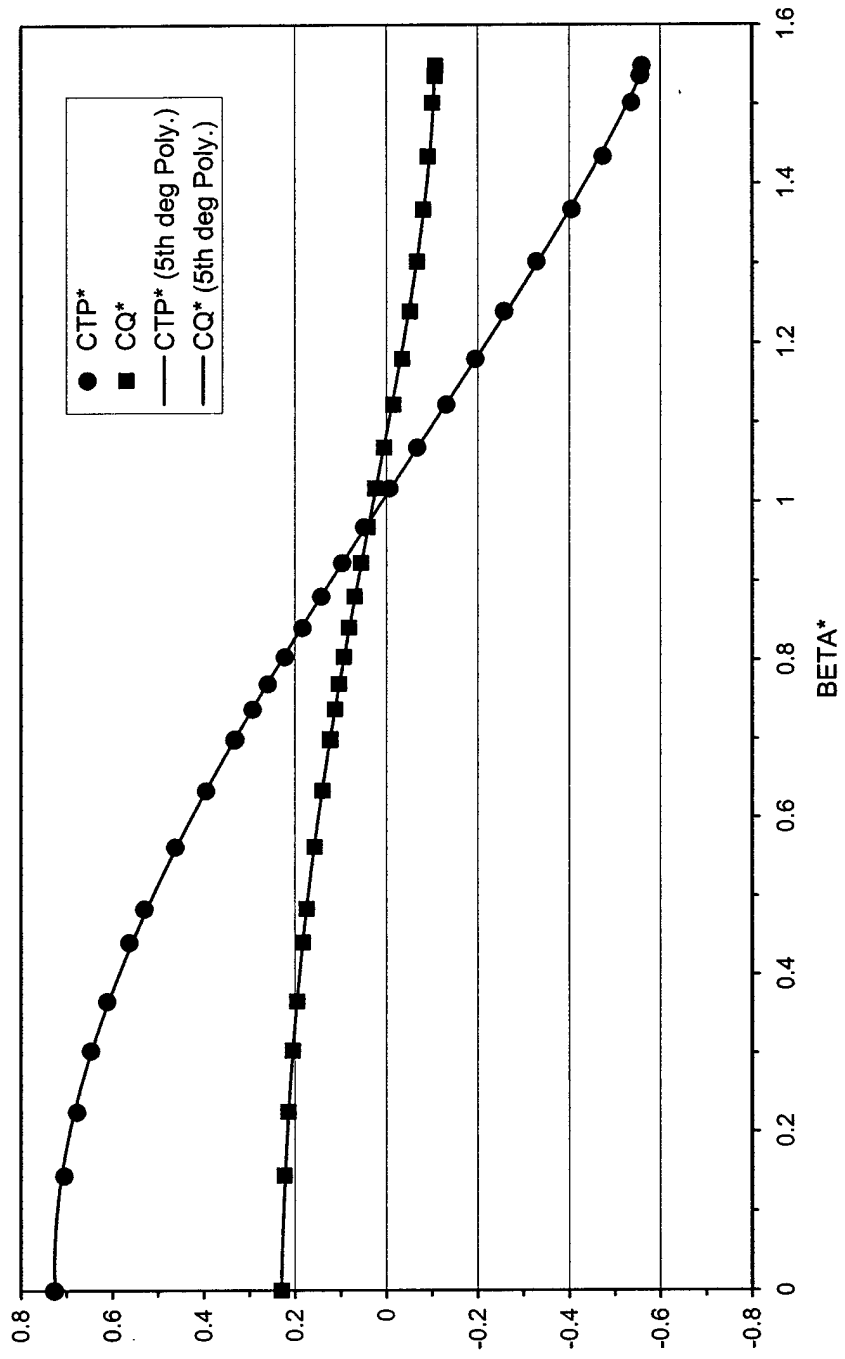

Figure 17. Open Water Rotor Performance Data at 6.5° of Pitch

AHEAD OPEN WATER EXPERIMENT @ 6.5° PITCH - NSWCCD TOWING BASIN CARRIAGE 2
 NOVEMBER 2001 - STRUT w/PROPULSOR 5408/5409 - EXP.18

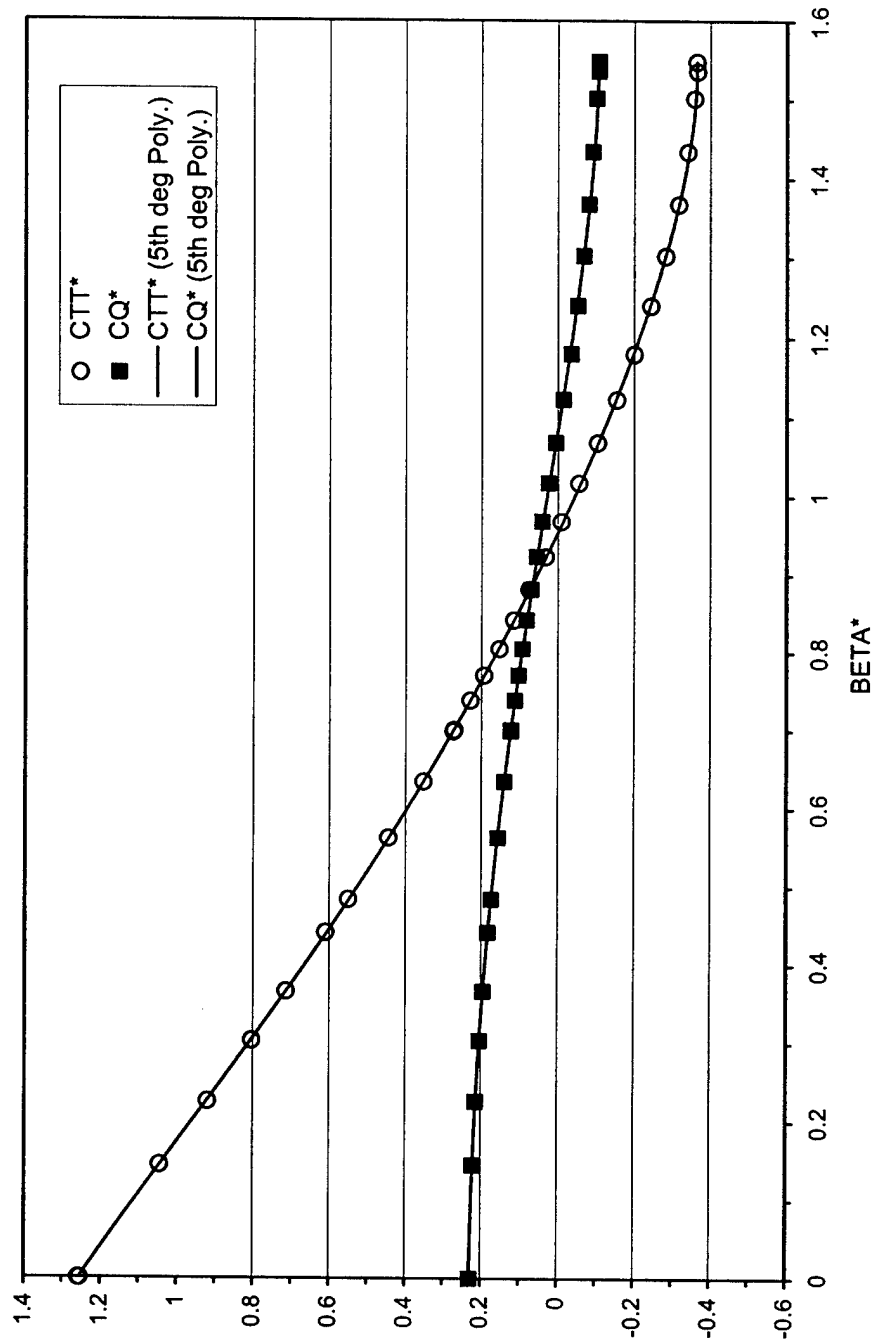

Figure 18. Open Water Propulsor Performance Data at 6.5° of Pitch.

AHEAD OPEN WATER EXPERIMENT @ 6.5° PITCH - NSWCCD TOWING BASIN CARRIAGE 2
 NOVEMBER 2001 - STRUT w/PROPULSOR 5408/5409 - EXP. 18

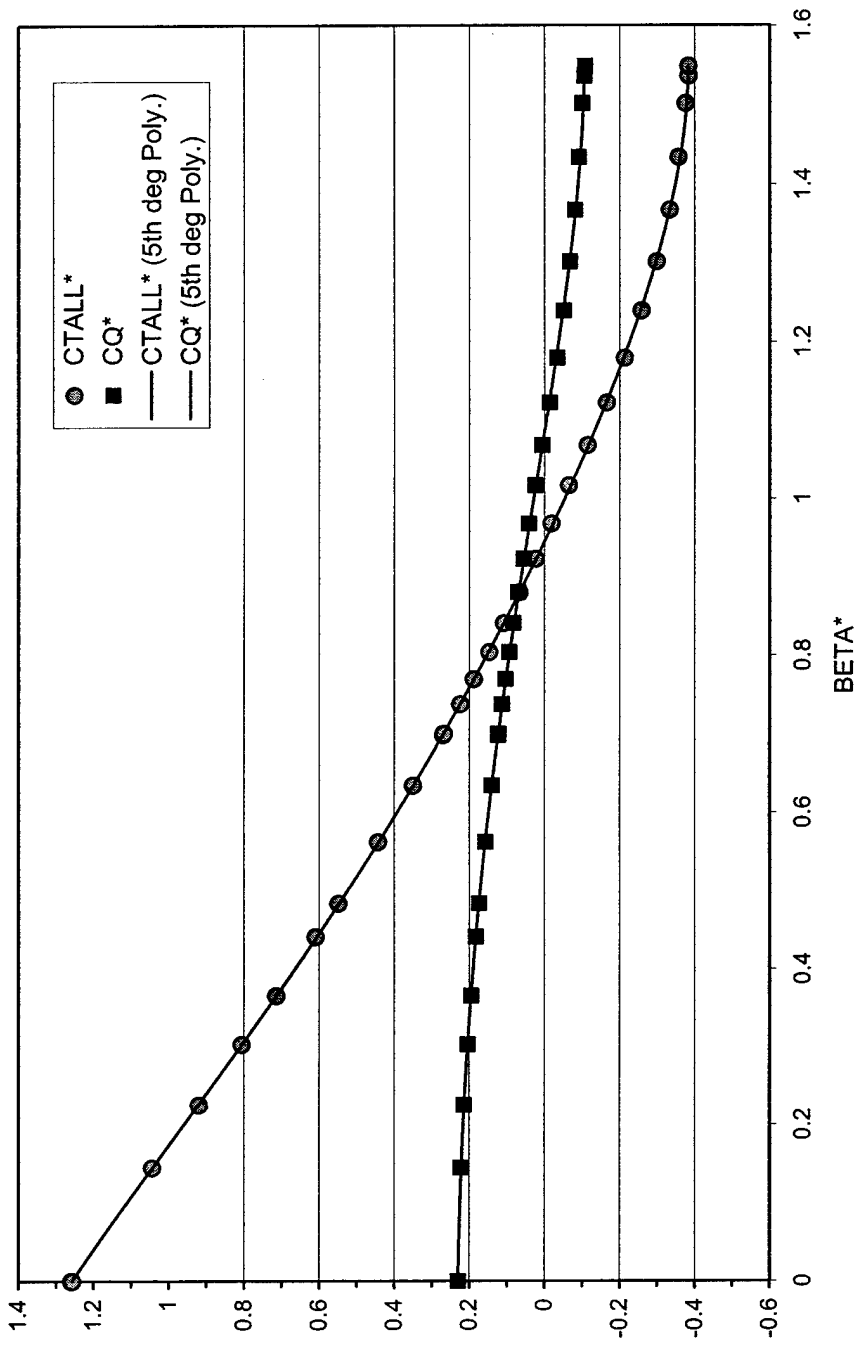

Figure 19. Open Water Propulsor and Strut Assembly Performance Data at 6.5° of Pitch

AHEAD OPEN WATER EXPERIMENT @ 6.5° PITCH - NSWCCD TOWING BASIN CARRIAGE 2
 NOVEMBER 2001 - STRUT w/PROPULSOR 5408/5409 - EXP. 18

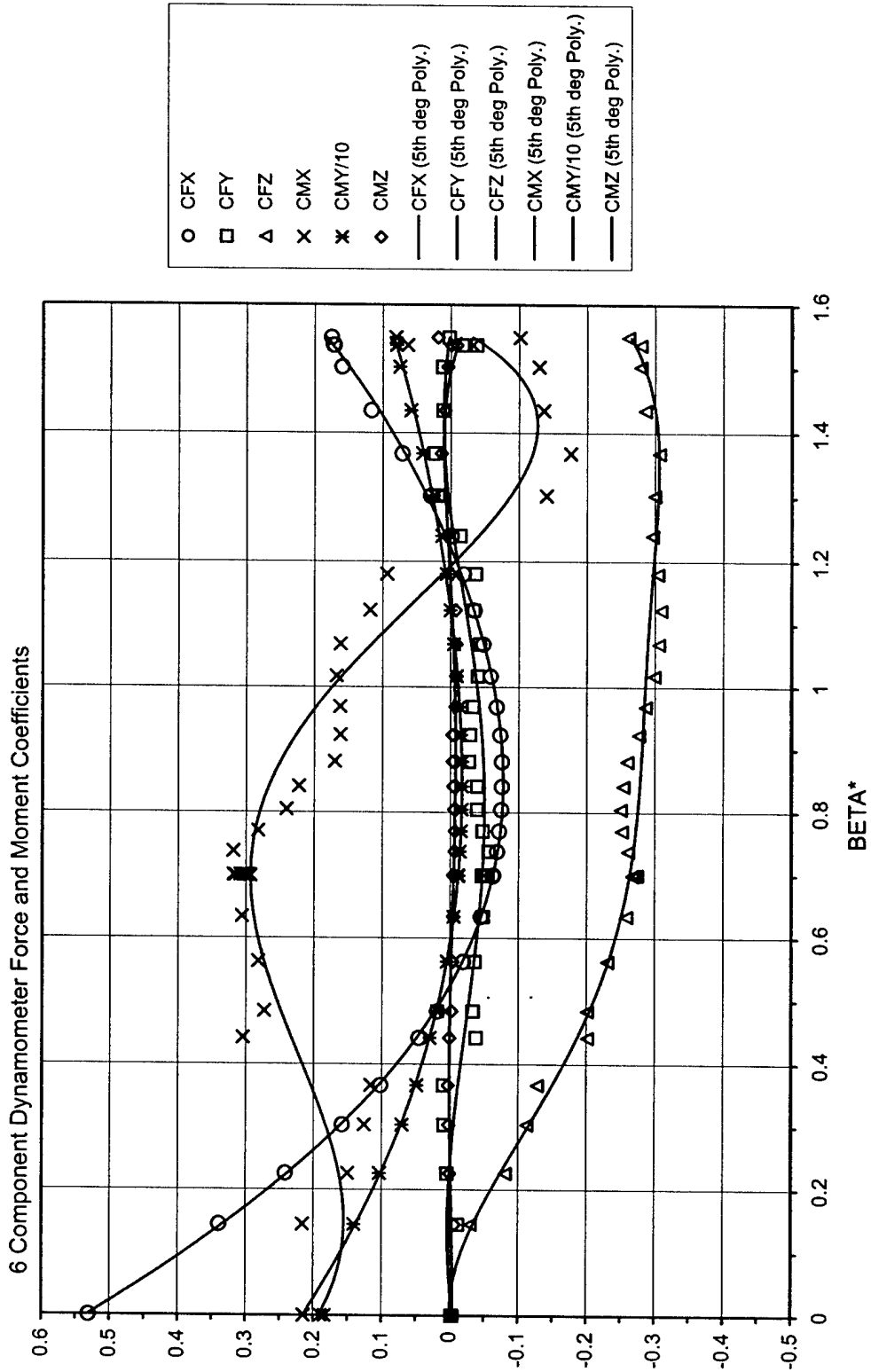

Figure 20. Open Water Duct and Strut Assembly Performance Data at 6.5° of Pitch

AHEAD OPEN WATER EXPERIMENT @ 6.5° PITCH - NSWCCD TOWING BASIN CARRIAGE 2
 NOVEMBER 2001 - STRUT w/PROPULSOR 5408/5409 - EXP. 18

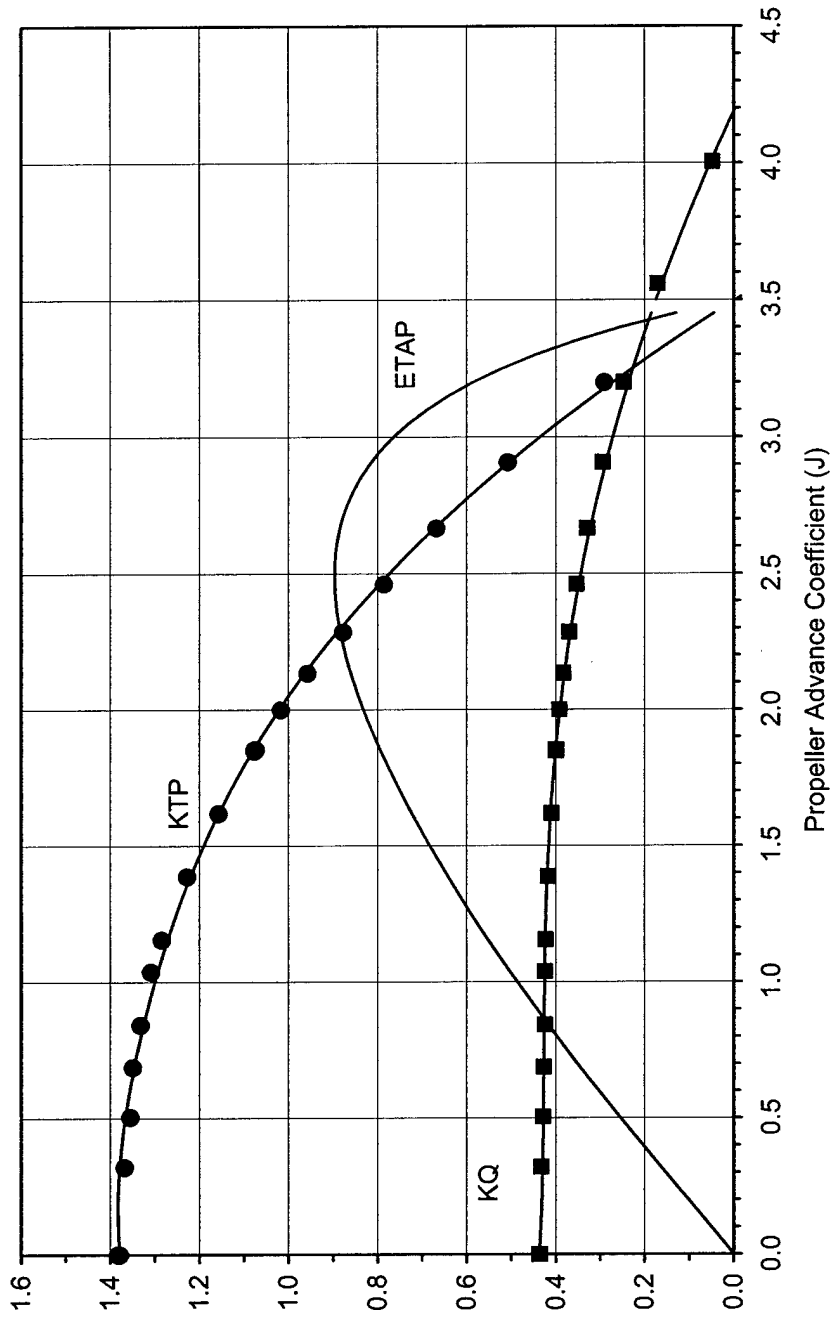

Figure 21. Open Water Rotor Performance Data at 6.5° of Pitch; KTP, KQ, and ETAP

AHEAD OPEN WATER EXPERIMENT @ 6.5° PITCH - NSWCCD TOWING BASIN CARRIAGE 2
 NOVEMBER 2001 - STRUT w/PROPULSOR 5408/5409 - EXP. 18

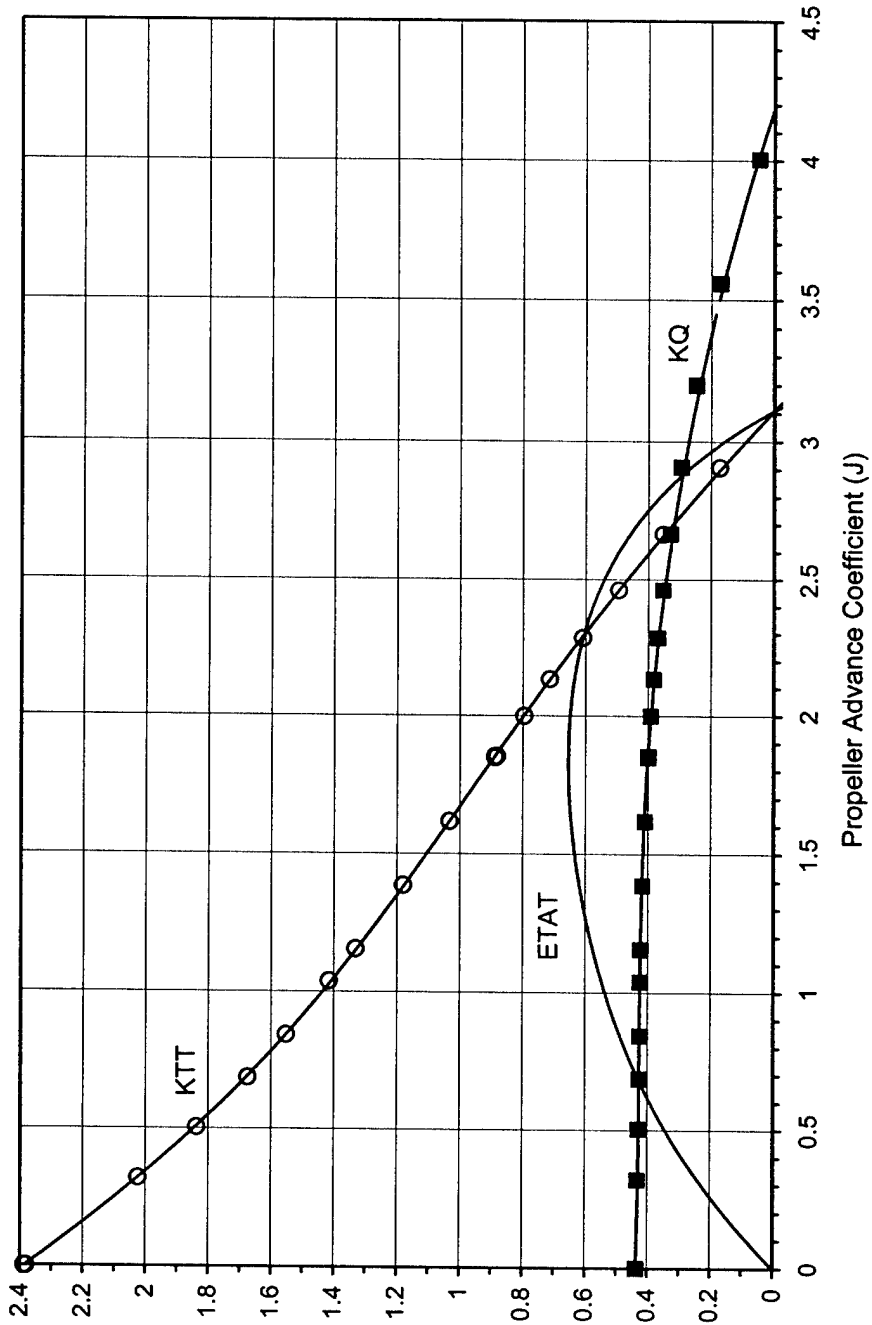

Figure 22. Open Water Propulsor Performance Data at 6.5° of Pitch; KTT, KQ, and ETAT

STRUT DRAG EXPERIMENT - NSWCCD TOWING BASIN CARRIAGE 2
 NOVEMBER 2001 - "V" STRUTS w/LOWER STRUT FAIRINGS - EXP. 22

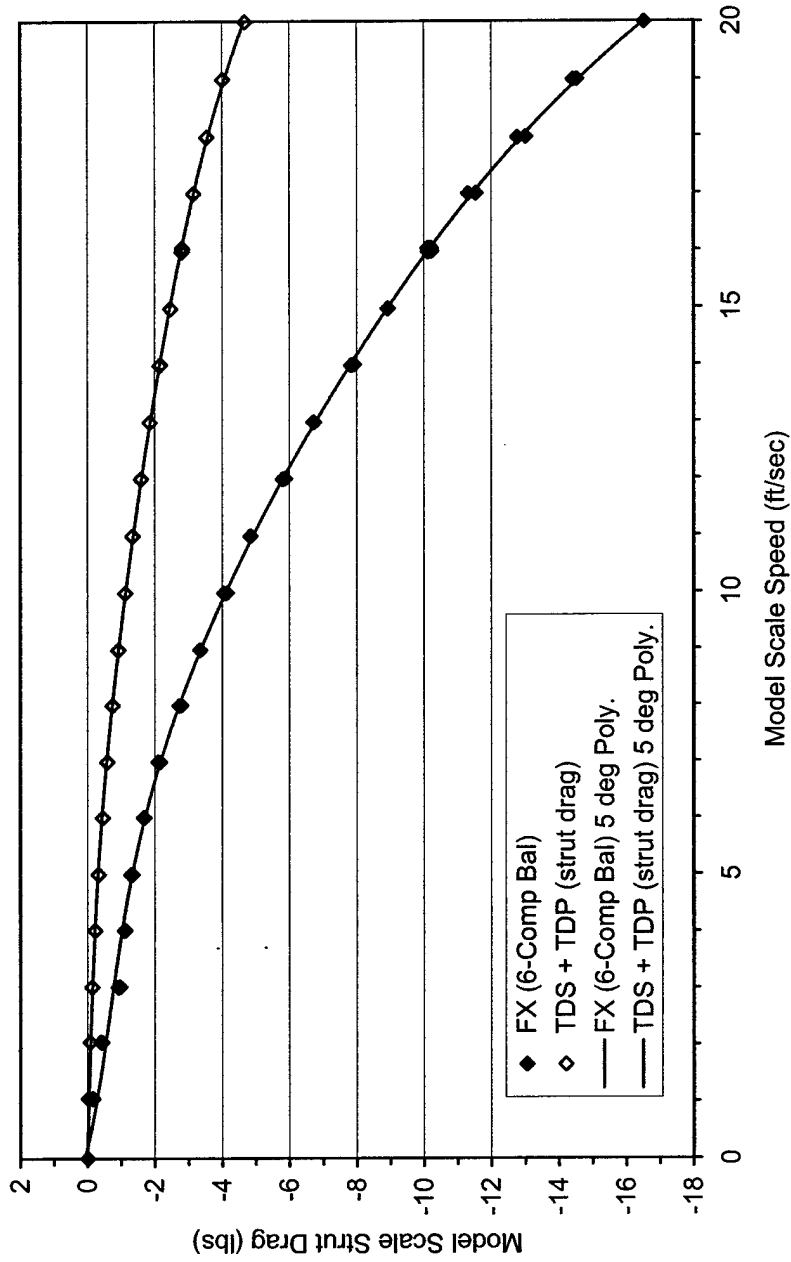

Figure 23. Strut Drag Results Presented in Physical Units

STRUT DRAG EXPERIMENT - NSWCCD TOWING BASIN CARRIAGE 2
 NOVEMBER 2001 - "V" STRUTS w/LOWER STRUT FAIRINGS - EXP. 22

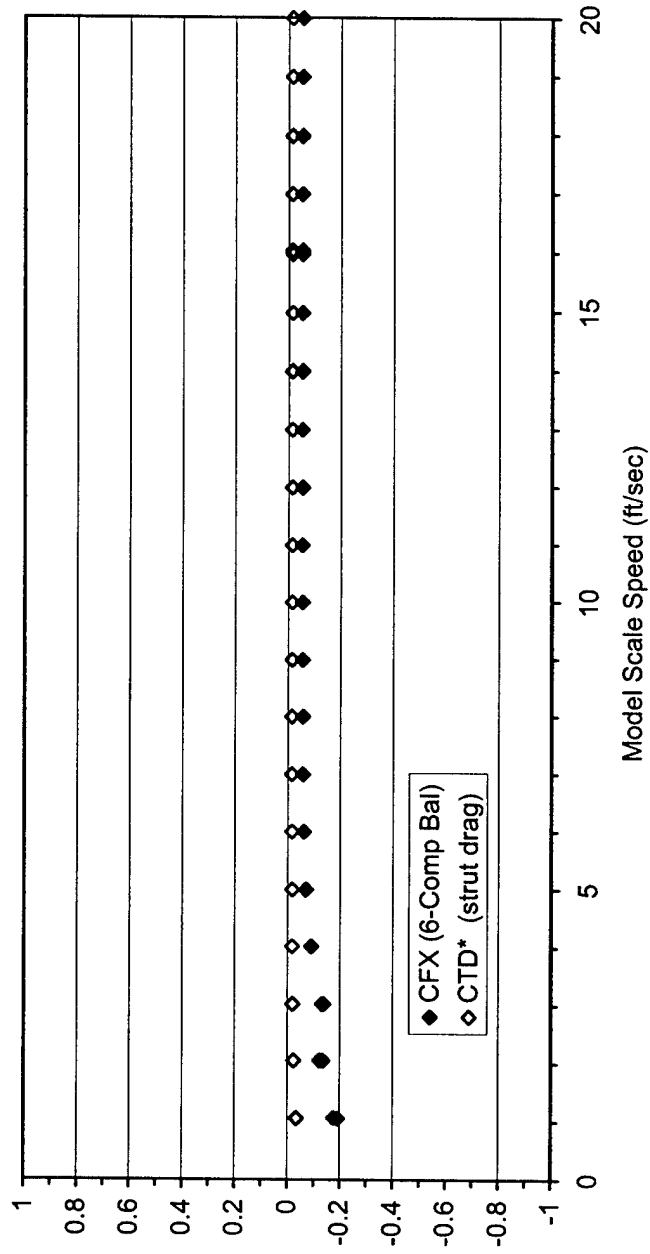

Figure 24. Strut Drag Results Presented in Coefficient Form

Table 1. Bollard Pull Data

BOLLARD EXPERIMENT - NSWCCD TOWING BASIN CARRIAGE 2
 NOVEMBER 2001 - STRUT w/PROPULSOR 5408/5409 - EXP. 12

Reynolds Number X 10 ⁻⁵	KTP	CTP*	KQ	CQ*	KTD	CTD*	KTT	CTT*
0.1042	0.5687	0.2995	-0.0291	-0.0153	-0.0807	-0.0425	0.4881	0.2570
0.5405	1.0583	0.5573	0.3529	0.1858	0.6364	0.3351	1.6947	0.8924
1.0878	1.3416	0.7064	0.4269	0.2248	0.9317	0.4906	2.2732	1.1970
1.6288	1.4229	0.7493	0.4497	0.2368	0.9841	0.5182	2.4071	1.2675
1.6289	1.4100	0.7424	0.4477	0.2357	0.9680	0.5097	2.3780	1.2521
2.1699	1.4321	0.7541	0.4498	0.2368	0.9964	0.5246	2.4285	1.2787
2.7172	1.4200	0.7477	0.4456	0.2346	1.0078	0.5307	2.4278	1.2784
2.7173	1.3966	0.7354	0.4397	0.2315	0.9999	0.5265	2.3965	1.2619
2.7173	1.4033	0.7389	0.4412	0.2323	0.9986	0.5258	2.4019	1.2647
3.2583	1.3930	0.7335	0.4414	0.2324	1.0254	0.5399	2.4184	1.2734
3.2583	1.3821	0.7277	0.4388	0.2311	1.0209	0.5376	2.4030	1.2653
3.7993	1.3486	0.7101	0.4378	0.2305	1.0629	0.5597	2.4115	1.2698
3.7994	1.3550	0.7135	0.4395	0.2314	1.0628	0.5596	2.4178	1.2731
4.3467	1.3196	0.6948	0.4383	0.2308	1.1063	0.5825	2.4259	1.2774

Table 2. Reynolds Number Variation Data

REYNOLDS NUMBER VARIATION EXPERIMENT - NSWCCD TOWING BASIN CARRIAGE 2
 NOVEMBER 2001 - STRUT w/PROPULSOR 5408/5409 - EXP. 15

Reynolds Number X 10 ⁻⁵	KTP	CTP*	KQ	CQ*	KTD	CTD*	KTT	CTT*
0.9196	0.9426	0.2904	0.3819	0.1176	-0.2777	-0.0855	0.6649	0.2048
0.9205	0.9554	0.2938	0.3763	0.1157	-0.2775	-0.0854	0.6778	0.2085
1.1490	0.9629	0.2969	0.3894	0.1201	-0.2576	-0.0794	0.7054	0.2175
1.3784	0.9977	0.3079	0.3956	0.1221	-0.2331	-0.0719	0.7646	0.2359
1.3792	0.9903	0.3053	0.3947	0.1217	-0.2446	-0.0754	0.7457	0.2299
1.3821	1.0006	0.3074	0.3939	0.1210	-0.2349	-0.0722	0.7657	0.2352
1.3845	0.9945	0.3044	0.3939	0.1206	-0.2357	-0.0722	0.7588	0.2322
1.6101	1.0105	0.3111	0.3983	0.1226	-0.2280	-0.0702	0.7825	0.2409
1.8407	1.0241	0.3152	0.4004	0.1233	-0.2219	-0.0683	0.8021	0.2469
1.8416	1.0255	0.3154	0.3986	0.1226	-0.2233	-0.0687	0.8022	0.2467
2.3007	1.0540	0.3246	0.4033	0.1242	-0.2095	-0.0645	0.8445	0.2601
2.7592	1.0564	0.3257	0.4038	0.1245	-0.2057	-0.0634	0.8507	0.2623
3.2209	1.0680	0.3289	0.4045	0.1246	-0.2013	-0.0620	0.8668	0.2669
3.6811	1.0678	0.3289	0.4040	0.1244	-0.1974	-0.0608	0.8704	0.2681
4.1420	1.0711	0.3298	0.4039	0.1243	-0.1927	-0.0593	0.8784	0.2704
4.5999	1.0678	0.3291	0.4026	0.1241	-0.1918	-0.0591	0.8760	0.2700
5.0616	1.0674	0.3287	0.4024	0.1239	-0.1892	-0.0583	0.8782	0.2704
5.5230	1.0667	0.3284	0.4012	0.1235	-0.1878	-0.0578	0.8789	0.2706
5.9835	1.0632	0.3272	0.4003	0.1232	-0.1869	-0.0575	0.8763	0.2697
6.4373	1.0673	0.3292	0.4000	0.1234	-0.1866	-0.0576	0.8807	0.2716
6.9046	1.0657	0.3280	0.3989	0.1228	-0.1890	-0.0582	0.8767	0.2698
7.3576	1.0741	0.3312	0.3992	0.1231	-0.1950	-0.0601	0.8791	0.2711
7.8191	1.0727	0.3306	0.3984	0.1228	-0.1946	-0.0600	0.8781	0.2707
8.2810	1.0748	0.3312	0.3979	0.1226	-0.1981	-0.0610	0.8767	0.2702
8.7394	1.0716	0.3303	0.3969	0.1223	-0.1996	-0.0615	0.8720	0.2688
9.2017	1.0570	0.3256	0.3967	0.1222	-0.1900	-0.0585	0.8670	0.2671
9.2020	1.0546	0.3249	0.3968	0.1222	-0.1866	-0.0575	0.8680	0.2674
9.2019	1.0539	0.3247	0.3969	0.1223	-0.1841	-0.0567	0.8698	0.2680

Table 3. Open Water Propulsor Performance Data at 0 degree of Pitch

AHEAD OPEN WATER EXPERIMENT AT 0 DEG PITCH
 NSWCCD TOWING BASIN CARRIAGE 2 - EXP. 16
 NOVEMBER 2001 - STRUT w/PROPULSOR 5408/5409

BETA*	CTP*	CQ*	CTT*	CTALL*	CTP	CQ	CTT
0.00	0.6963	0.2274	1.2358	1.2358	*	*	*
0.05	0.7082	0.2270	1.1701	1.1687	283.5135	90.8799	468.4461
0.10	0.7109	0.2252	1.1008	1.0983	71.3303	22.5931	110.4450
0.15	0.7056	0.2221	1.0289	1.0257	31.5972	9.9447	46.0757
0.20	0.6932	0.2178	0.9557	0.9519	17.5637	5.5189	24.2140
0.25	0.6746	0.2125	0.8819	0.8776	11.0216	3.4717	14.4086
0.30	0.6505	0.2062	0.8083	0.8034	7.4490	2.3606	9.2557
0.35	0.6217	0.1989	0.7355	0.7300	5.2874	1.6912	6.2551
0.40	0.5886	0.1906	0.6638	0.6575	3.8817	1.2571	4.3775
0.45	0.5520	0.1815	0.5938	0.5865	2.9174	0.9594	3.1384
0.50	0.5121	0.1715	0.5255	0.5171	2.2278	0.7462	2.2863
0.55	0.4694	0.1607	0.4592	0.4494	1.7181	0.5880	1.6809
0.60	0.4243	0.1490	0.3950	0.3837	1.3307	0.4672	1.2389
0.65	0.3770	0.1364	0.3329	0.3199	1.0293	0.3725	0.9089
0.70	0.3279	0.1231	0.2729	0.2581	0.7900	0.2967	0.6576
0.75	0.2771	0.1091	0.2150	0.1983	0.5963	0.2347	0.4627
0.80	0.2249	0.0943	0.1591	0.1404	0.4370	0.1832	0.3091
0.85	0.1714	0.0789	0.1051	0.0845	0.3037	0.1397	0.1863
0.90	0.1169	0.0629	0.0532	0.0305	0.1906	0.1025	0.0866
0.95	0.0616	0.0464	0.0031	-0.0214	0.0930	0.0702	0.0047
1.00	0.0055	0.0296	-0.0450	-0.0713	0.0078	0.0418	-0.0636
1.05	-0.0511	0.0127	-0.0912	-0.1191	-0.0679	0.0168	-0.1211
1.10	-0.1079	-0.0043	-0.1351	-0.1645	-0.1359	-0.0054	-0.1701
1.15	-0.1648	-0.0210	-0.1766	-0.2073	-0.1978	-0.0252	-0.2120
1.20	-0.2215	-0.0372	-0.2155	-0.2473	-0.2550	-0.0428	-0.2481
1.25	-0.2777	-0.0526	-0.2512	-0.2839	-0.3084	-0.0585	-0.2789
1.30	-0.3331	-0.0669	-0.2833	-0.3166	-0.3587	-0.0721	-0.3051
1.35	-0.3871	-0.0797	-0.3110	-0.3448	-0.4066	-0.0837	-0.3266
1.40	-0.4395	-0.0905	-0.3335	-0.3677	-0.4526	-0.0932	-0.3434
1.45	-0.4897	-0.0989	-0.3499	-0.3844	-0.4969	-0.1003	-0.3550
1.50	-0.5370	-0.1042	-0.3589	-0.3939	-0.5397	-0.1047	-0.3607
1.55	-0.5808	-0.1060	-0.3593	-0.3947	-0.5811	-0.1060	-0.3594

5th Degree Polynomial Coefficients

X ⁵	0.18409083	0.08320702	0.36315308	0.3161425
X ⁴	-0.80696748	-0.20902282	-1.37528735	-1.18063238
X ³	1.652103	0.23231517	2.01203868	1.74674597
X ²	-2.05568421	-0.31058181	-1.01265159	-0.88609974
X	0.33561668	0.00627096	-1.26812373	-1.30331708
1	0.6963453	0.2274441	1.2358263	1.23582321

Note: * Division by zero.

Table 4. Open Water Duct and Strut Assembly Performance Data at 0 degree of Pitch

AHEAD OPEN WATER EXPERIMENT AT 0 DEG PITCH
 6 COMPONENT DYNAMOMETER FORCES AND MOMENTS
 NSWCCD TOWING BASIN CARRIAGE 2 - EXP. 16
 NOVEMBER 2001 - STRUT w/PROPULSOR 5408/5409

BETA*	CFX	CFY	CFZ	CMX	CMY/10	CMZ
0.00	0.5395	0.0299	-0.0492	0.0498	0.2215	0.0110
0.05	0.4605	0.0357	-0.0308	0.0245	0.1888	0.0131
0.10	0.3873	0.0378	-0.0187	0.0142	0.1587	0.0136
0.15	0.3201	0.0371	-0.0116	0.0153	0.1311	0.0129
0.20	0.2587	0.0344	-0.0081	0.0245	0.1060	0.0115
0.25	0.2030	0.0303	-0.0070	0.0394	0.0834	0.0097
0.30	0.1529	0.0253	-0.0075	0.0575	0.0631	0.0076
0.35	0.1083	0.0198	-0.0088	0.0772	0.0451	0.0055
0.40	0.0689	0.0141	-0.0102	0.0969	0.0293	0.0036
0.45	0.0345	0.0084	-0.0112	0.1155	0.0155	0.0020
0.50	0.0050	0.0030	-0.0114	0.1321	0.0037	0.0007
0.55	-0.0199	-0.0021	-0.0105	0.1463	-0.0063	-0.0003
0.60	-0.0405	-0.0067	-0.0083	0.1575	-0.0145	-0.0010
0.65	-0.0571	-0.0109	-0.0048	0.1656	-0.0211	-0.0013
0.70	-0.0697	-0.0147	0.0000	0.1705	-0.0261	-0.0013
0.75	-0.0788	-0.0180	0.0061	0.1722	-0.0297	-0.0011
0.80	-0.0845	-0.0208	0.0134	0.1707	-0.0319	-0.0007
0.85	-0.0869	-0.0232	0.0217	0.1662	-0.0329	-0.0002
0.90	-0.0864	-0.0251	0.0307	0.1588	-0.0327	0.0003
0.95	-0.0830	-0.0265	0.0403	0.1483	-0.0313	0.0009
1.00	-0.0768	-0.0273	0.0501	0.1348	-0.0289	0.0013
1.05	-0.0680	-0.0273	0.0599	0.1180	-0.0254	0.0017
1.10	-0.0566	-0.0263	0.0694	0.0974	-0.0208	0.0021
1.15	-0.0425	-0.0242	0.0784	0.0724	-0.0152	0.0024
1.20	-0.0257	-0.0204	0.0866	0.0423	-0.0085	0.0027
1.25	-0.0061	-0.0146	0.0938	0.0056	-0.0007	0.0031
1.30	0.0165	-0.0063	0.0999	-0.0389	0.0084	0.0039
1.35	0.0423	0.0054	0.1048	-0.0933	0.0188	0.0051
1.40	0.0718	0.0211	0.1084	-0.1598	0.0306	0.0070
1.45	0.1052	0.0418	0.1107	-0.2411	0.0441	0.0099
1.50	0.1432	0.0685	0.1119	-0.3405	0.0594	0.0143
1.55	0.1861	0.1026	0.1122	-0.4617	0.0767	0.0205

5th Degree Polynomial Coefficients

X ⁵	0.13205167	0.28593916	0.27792678	-1.0320878	0.049106	0.13947394
X ⁴	-0.3736649	-1.0202758	-1.3759207	3.97943837	-0.1260275	-0.540586
X ³	0.09464297	1.44617179	2.35956348	-6.0187898	-0.0147603	0.75172962
X ²	1.16958447	-0.9265786	-1.6052299	3.83994255	0.52112782	-0.4210015
X	-1.6389338	0.15755697	0.44296788	-0.6834548	-0.6797936	0.06068446
1	0.53947791	0.02993377	-0.0491987	0.04975567	0.22146497	0.01103068

Table 5. Open Water Propulsor Performance Data at 0 degree of Pitch
Presented as Thrust and Torque Coefficients

AHEAD OPEN WATER EXPERIMENT AT 0 DEG PITCH
NSWCDD TOWING BASIN CARRIAGE 2 - EXP. 16
NOVEMBER 2001 - STRUT w/PROPULSOR 5408/5409

J	KTP	KQ	ETAP	KTT	ETAT
0.000	1.322	0.432	0.000	2.347	0.000
0.050	1.336	0.432	0.025	2.292	0.042
0.100	1.346	0.432	0.050	2.239	0.082
0.150	1.355	0.432	0.075	2.185	0.121
0.200	1.362	0.432	0.100	2.133	0.157
0.250	1.366	0.432	0.126	2.081	0.192
0.300	1.369	0.432	0.152	2.031	0.225
0.350	1.371	0.431	0.177	1.981	0.256
0.400	1.371	0.431	0.203	1.933	0.286
0.450	1.371	0.431	0.228	1.886	0.314
0.500	1.369	0.430	0.253	1.839	0.340
0.550	1.366	0.430	0.278	1.794	0.365
0.600	1.362	0.430	0.303	1.750	0.389
0.650	1.357	0.429	0.327	1.707	0.412
0.700	1.351	0.429	0.351	1.666	0.433
0.750	1.345	0.428	0.375	1.625	0.453
0.800	1.338	0.428	0.398	1.585	0.472
0.850	1.331	0.428	0.421	1.546	0.489
0.900	1.323	0.427	0.444	1.508	0.506
0.950	1.314	0.427	0.466	1.471	0.522
1.000	1.305	0.426	0.488	1.435	0.536
1.050	1.295	0.425	0.509	1.399	0.550
1.100	1.285	0.425	0.530	1.365	0.563
1.150	1.274	0.424	0.550	1.330	0.575
1.200	1.263	0.423	0.570	1.297	0.586
1.250	1.251	0.422	0.590	1.264	0.596
1.300	1.239	0.421	0.609	1.231	0.605
1.350	1.226	0.420	0.628	1.199	0.614
1.400	1.213	0.418	0.646	1.167	0.621
1.450	1.199	0.417	0.663	1.135	0.628
1.500	1.184	0.415	0.680	1.104	0.634
1.550	1.169	0.414	0.697	1.073	0.640
1.600	1.153	0.412	0.713	1.042	0.644
1.650	1.137	0.410	0.729	1.011	0.648
1.700	1.120	0.408	0.743	0.980	0.651
1.750	1.102	0.405	0.758	0.949	0.652
1.800	1.084	0.403	0.771	0.918	0.653
1.850	1.065	0.400	0.784	0.887	0.653
1.900	1.046	0.397	0.797	0.856	0.652
1.950	1.025	0.394	0.808	0.825	0.650
2.000	1.004	0.390	0.819	0.793	0.647
2.050	0.982	0.387	0.829	0.762	0.643
2.100	0.960	0.383	0.838	0.730	0.637
2.150	0.936	0.379	0.845	0.697	0.630
2.200	0.912	0.375	0.852	0.665	0.621
2.250	0.887	0.370	0.858	0.632	0.611
2.300	0.861	0.365	0.863	0.599	0.599
2.350	0.835	0.361	0.866	0.565	0.586
2.400	0.807	0.355	0.868	0.531	0.570
2.450	0.779	0.350	0.868	0.496	0.553
2.500	0.749	0.344	0.866	0.461	0.533
2.550	0.719	0.338	0.863	0.425	0.510
2.600	0.688	0.332	0.857	0.389	0.485
2.650	0.656	0.326	0.850	0.352	0.456
2.700	0.623	0.319	0.840	0.315	0.425
2.750	0.589	0.312	0.827	0.277	0.389
2.800	0.555	0.305	0.811	0.239	0.350
2.850	0.519	0.297	0.791	0.200	0.305
2.900	0.482	0.290	0.768	0.161	0.256
2.950	0.444	0.282	0.741	0.121	0.201
3.000	0.406	0.273	0.708	0.080	0.139
3.050	0.366	0.265	0.671	0.038	0.070
3.100	0.325	0.256	0.626	-0.004	-0.007
3.150	0.284	0.247	0.575		
3.200	0.241	0.238	0.516		
3.250	0.197	0.228	0.446		
3.300	0.152	0.218	0.366		
3.350	0.106	0.208	0.272		
3.400	0.060	0.198	0.163		
3.450	0.012	0.187	0.034		

Table 6. Open Water Propulsor Performance Data at 6.5 degree of Pitch

AHEAD OPEN WATER EXPERIMENT AT 6.5 DEG PITCH
 NSWCCD TOWING BASIN CARRIAGE 2 - EXP. 18
 NOVEMBER 2001 - STRUT w/PROPULSOR 5408/5409

BETA*	CTP*	CQ*	CTT*	CTALL*	CTP	CQ	CTT
					*	*	*
0.00	0.7253	0.2301	1.2556	1.2576			
0.05	0.7260	0.2278	1.1840	1.1856	290.6559	91.1962	473.9903
0.10	0.7205	0.2248	1.1102	1.1115	72.2956	22.5558	111.3890
0.15	0.7095	0.2211	1.0351	1.0363	31.7692	9.9004	46.3516
0.20	0.6933	0.2166	0.9596	0.9606	17.5650	5.4881	24.3117
0.25	0.6725	0.2113	0.8842	0.8851	10.9864	3.4525	14.4460
0.30	0.6474	0.2052	0.8096	0.8104	7.4133	2.3495	9.2704
0.35	0.6185	0.1982	0.7362	0.7367	5.2605	1.6854	6.2610
0.40	0.5861	0.1902	0.6642	0.6645	3.8649	1.2546	4.3801
0.45	0.5504	0.1814	0.5940	0.5939	2.9094	0.9588	3.1399
0.50	0.5118	0.1716	0.5258	0.5252	2.2268	0.7467	2.2877
0.55	0.4705	0.1609	0.4596	0.4584	1.7221	0.5890	1.6824
0.60	0.4267	0.1493	0.3956	0.3936	1.3382	0.4682	1.2407
0.65	0.3805	0.1367	0.3336	0.3308	1.0390	0.3734	0.9109
0.70	0.3323	0.1234	0.2738	0.2701	0.8008	0.2972	0.6598
0.75	0.2822	0.1092	0.2161	0.2113	0.6075	0.2350	0.4651
0.80	0.2305	0.0943	0.1604	0.1546	0.4478	0.1832	0.3117
0.85	0.1772	0.0787	0.1067	0.0998	0.3139	0.1394	0.1890
0.90	0.1226	0.0626	0.0549	0.0469	0.1998	0.1020	0.0895
0.95	0.0669	0.0461	0.0051	-0.0040	0.1012	0.0697	0.0078
1.00	0.0104	0.0293	-0.0427	-0.0529	0.0147	0.0414	-0.0603
1.05	-0.0466	0.0125	-0.0884	-0.0998	-0.0620	0.0166	-0.1175
1.10	-0.1040	-0.0043	-0.1320	-0.1444	-0.1309	-0.0054	-0.1662
1.15	-0.1613	-0.0207	-0.1732	-0.1866	-0.1937	-0.0249	-0.2079
1.20	-0.2183	-0.0366	-0.2118	-0.2260	-0.2513	-0.0422	-0.2439
1.25	-0.2745	-0.0517	-0.2474	-0.2624	-0.3048	-0.0574	-0.2748
1.30	-0.3295	-0.0656	-0.2796	-0.2953	-0.3549	-0.0706	-0.3011
1.35	-0.3828	-0.0780	-0.3077	-0.3241	-0.4021	-0.0820	-0.3232
1.40	-0.4338	-0.0887	-0.3312	-0.3481	-0.4467	-0.0913	-0.3410
1.45	-0.4820	-0.0971	-0.3491	-0.3666	-0.4891	-0.0985	-0.3542
1.50	-0.5266	-0.1029	-0.3605	-0.3785	-0.5293	-0.1034	-0.3623
1.55	-0.5670	-0.1056	-0.3644	-0.3828	-0.5673	-0.1056	-0.3645

5th Degree Polynomial Coefficients

X ⁵	0.12385431	0.03179767	0.29054654	0.27233814
X ⁴	-0.4389821	-0.0028272	-1.0823629	-1.0030849
X ³	0.87905939	-0.0650849	1.5502778	1.43792663
X ²	-1.3582949	-0.1246405	-0.6534633	-0.603303
X	0.07946254	-0.040044	-1.4032565	-1.4144358
1	0.72534475	0.230121	1.25558974	1.25764031

Note: * Division by zero.

Table 7. Open Water Duct and Strut Assembly Performance Data at 6.5 degree of Pitch

AHEAD OPEN WATER EXPERIMENT AT 6.5 DEG PITCH
 6 COMPONENT DYNAMOMETER FORCES AND MOMENTS
 NSWCCD TOWING BASIN CARRIAGE 2 - EXP. 18
 NOVEMBER 2001 - STRUT w/PROPULSOR 5408/5409

BETA*	CFX	CFY	CFZ	CMX	CMY/10	CMZ
0.00	0.5323	-0.0044	-0.0013	0.1922	0.2154	-0.0039
0.05	0.4596	0.0002	-0.0038	0.1710	0.1871	-0.0041
0.10	0.3910	0.0027	-0.0163	0.1591	0.1605	-0.0036
0.15	0.3268	0.0032	-0.0358	0.1554	0.1358	-0.0027
0.20	0.2673	0.0019	-0.0600	0.1587	0.1130	-0.0016
0.25	0.2127	-0.0009	-0.0866	0.1680	0.0921	-0.0006
0.30	0.1630	-0.0049	-0.1140	0.1817	0.0732	0.0002
0.35	0.1182	-0.0099	-0.1410	0.1986	0.0562	0.0006
0.40	0.0784	-0.0156	-0.1664	0.2173	0.0412	0.0007
0.45	0.0435	-0.0216	-0.1895	0.2363	0.0280	0.0004
0.50	0.0133	-0.0277	-0.2100	0.2545	0.0167	-0.0002
0.55	-0.0121	-0.0335	-0.2275	0.2704	0.0071	-0.0012
0.60	-0.0331	-0.0388	-0.2420	0.2829	-0.0007	-0.0023
0.65	-0.0497	-0.0434	-0.2537	0.2909	-0.0069	-0.0036
0.70	-0.0623	-0.0469	-0.2628	0.2936	-0.0115	-0.0048
0.75	-0.0709	-0.0491	-0.2697	0.2902	-0.0147	-0.0059
0.80	-0.0759	-0.0500	-0.2747	0.2803	-0.0164	-0.0068
0.85	-0.0774	-0.0495	-0.2784	0.2635	-0.0169	-0.0073
0.90	-0.0757	-0.0474	-0.2812	0.2398	-0.0161	-0.0074
0.95	-0.0709	-0.0438	-0.2835	0.2096	-0.0141	-0.0070
1.00	-0.0634	-0.0388	-0.2858	0.1734	-0.0111	-0.0061
1.05	-0.0531	-0.0326	-0.2884	0.1323	-0.0071	-0.0047
1.10	-0.0404	-0.0255	-0.2913	0.0875	-0.0021	-0.0027
1.15	-0.0252	-0.0177	-0.2947	0.0409	0.0038	-0.0003
1.20	-0.0077	-0.0099	-0.2983	-0.0054	0.0106	0.0023
1.25	0.0121	-0.0024	-0.3018	-0.0488	0.0183	0.0050
1.30	0.0342	0.0039	-0.3046	-0.0859	0.0269	0.0076
1.35	0.0587	0.0082	-0.3057	-0.1132	0.0364	0.0095
1.40	0.0857	0.0097	-0.3039	-0.1264	0.0468	0.0106
1.45	0.1154	0.0071	-0.2977	-0.1207	0.0582	0.0101
1.50	0.1481	-0.0006	-0.2852	-0.0906	0.0707	0.0076
1.55	0.1842	-0.0149	-0.2638	-0.0300	0.0844	0.0023

5th Degree Polynomial Coefficients

X ⁵	0.14848383	-0.1937104	0.84415171	0.76406214	0.04857571	-0.1727749
X ⁴	-0.5641028	0.38393859	-3.4118711	-1.275103	-0.1793956	0.5881527
X ³	0.55886724	0.10838294	4.88446902	-1.0030501	0.15287854	-0.6458062
X ²	0.75499195	-0.4468756	-2.6729221	2.01682332	0.33537443	0.24439355
X	-1.4938983	0.11386004	0.07161523	-0.5214689	-0.5839794	-0.0162233
1	0.53229556	-0.0043941	-0.0012633	0.19218132	0.2154195	-0.0038691

Table 8. Open Water Propulsor Performance Data at 6.5 degree of Pitch
Presented as Thrust & Torque Coefficients

AHEAD OPEN WATER EXPERIMENT AT 6.5 DEG PITCH
NSWCCD TOWING BASIN CARRIAGE 2 - EXP. 18
NOVEMBER 2001 - STRUT w/PROPULSOR 5408/5409

J	KTP	KQ	ETAP	KTT	ETAT
0.000	1.378	0.437	0.000	2.385	0.000
0.050	1.380	0.435	0.025	2.325	0.042
0.100	1.382	0.434	0.051	2.266	0.083
0.150	1.383	0.433	0.076	2.208	0.122
0.200	1.383	0.432	0.102	2.152	0.159
0.250	1.381	0.431	0.128	2.098	0.194
0.300	1.380	0.430	0.153	2.044	0.227
0.350	1.377	0.429	0.179	1.993	0.259
0.400	1.374	0.429	0.204	1.942	0.288
0.450	1.370	0.428	0.229	1.893	0.317
0.500	1.366	0.428	0.254	1.845	0.343
0.550	1.362	0.428	0.279	1.799	0.368
0.600	1.356	0.427	0.303	1.754	0.392
0.650	1.351	0.427	0.327	1.711	0.414
0.700	1.345	0.427	0.351	1.668	0.435
0.750	1.338	0.427	0.374	1.627	0.455
0.800	1.332	0.427	0.397	1.587	0.474
0.850	1.324	0.426	0.420	1.547	0.491
0.900	1.317	0.426	0.443	1.509	0.507
0.950	1.309	0.426	0.465	1.472	0.523
1.000	1.300	0.425	0.486	1.436	0.537
1.050	1.292	0.425	0.508	1.400	0.550
1.100	1.282	0.425	0.529	1.365	0.563
1.150	1.273	0.424	0.549	1.331	0.575
1.200	1.262	0.423	0.570	1.298	0.586
1.250	1.252	0.422	0.590	1.265	0.596
1.300	1.241	0.421	0.609	1.232	0.605
1.350	1.229	0.420	0.628	1.200	0.613
1.400	1.217	0.419	0.647	1.168	0.621
1.450	1.204	0.418	0.665	1.137	0.628
1.500	1.191	0.416	0.683	1.106	0.634
1.550	1.177	0.415	0.700	1.075	0.639
1.600	1.162	0.413	0.717	1.044	0.644
1.650	1.147	0.411	0.733	1.013	0.648
1.700	1.131	0.408	0.749	0.982	0.651
1.750	1.115	0.406	0.765	0.952	0.653
1.800	1.098	0.403	0.779	0.921	0.654
1.850	1.080	0.401	0.794	0.890	0.654
1.900	1.061	0.398	0.807	0.859	0.654
1.950	1.042	0.394	0.820	0.828	0.652
2.000	1.022	0.391	0.832	0.797	0.649
2.050	1.001	0.387	0.843	0.766	0.645
2.100	0.979	0.383	0.854	0.734	0.640
2.150	0.956	0.379	0.863	0.702	0.634
2.200	0.933	0.375	0.872	0.670	0.626
2.250	0.909	0.370	0.879	0.637	0.616
2.300	0.884	0.365	0.886	0.604	0.605
2.350	0.858	0.360	0.891	0.570	0.592
2.400	0.831	0.355	0.894	0.537	0.577
2.450	0.803	0.349	0.896	0.502	0.561
2.500	0.774	0.343	0.897	0.467	0.541
2.550	0.745	0.337	0.896	0.432	0.520
2.600	0.714	0.331	0.893	0.396	0.495
2.650	0.683	0.325	0.887	0.360	0.468
2.700	0.650	0.318	0.880	0.323	0.437
2.750	0.617	0.311	0.869	0.286	0.403
2.800	0.583	0.303	0.856	0.248	0.364
2.850	0.547	0.296	0.839	0.210	0.321
2.900	0.511	0.288	0.819	0.171	0.273
2.950	0.474	0.280	0.794	0.131	0.219
3.000	0.435	0.272	0.765	0.091	0.159
3.050	0.396	0.263	0.730	0.050	0.092
3.100	0.356	0.254	0.690	0.008	0.016
3.150	0.314	0.245	0.642	-0.034	-0.069
3.200	0.272	0.236	0.587		
3.250	0.228	0.226	0.522		
3.300	0.184	0.216	0.446		
3.350	0.138	0.206	0.357		
3.400	0.092	0.196	0.253		
3.450	0.044	0.185	0.130		

Table 9. Comparison of Open Water Performance Results
for the AHFID Propulsor

Propeller Models 5408 and 5409:

$$J = 1.85$$

$$\beta^* = 0.70$$

	NSWCCD Experimental Data		
	0 degrees Pitch	6.5 degrees Pitch	6.5 deg. / 0 deg.
KTP	1.065	1.080	1.014
KTT	0.887	0.890	1.003
KTD=KTT-KTP	-0.178	-0.190	1.067
KQ	0.400	0.401	1.003
ETAT	0.653	0.654	1.002

Table 10. Strut Drag Results in Faired Physical Units

STRUT DRAG EXPERIMENT - NSWCCD TOWING BASIN CARRIAGE 2
 NOVEMBER 2001 - "V" STRUTS w/LOWER STRUT FAIRINGS - EXP. 22

VS (ft/sec)	FX (6-Comp Bal) (lbs)	TDS + TDP (lower strut drag) (lbs)
0	0.0873	0.0144
1	-0.2670	-0.0374
2	-0.5307	-0.0856
3	-0.7655	-0.1418
4	-1.0184	-0.2139
5	-1.3230	-0.3073
6	-1.7014	-0.4246
7	-2.1665	-0.5666
8	-2.7236	-0.7327
9	-3.3723	-0.9212
10	-4.1084	-1.1303
11	-4.9261	-1.3580
12	-5.8195	-1.6032
13	-6.7846	-1.8657
14	-7.8216	-2.1471
15	-8.9361	-2.4509
16	-10.1416	-2.7836
17	-11.4611	-3.1545
18	-12.9291	-3.5769
19	-14.5936	-4.0681
20	-16.5177	-4.6501

5th Degree Polynomial Coefficients

X ⁵	-1.58506E-05	-4.2467E-06
X ⁴	0.000789556	0.000186701
X ³	-0.014669475	-0.002942097
X ²	0.084086928	0.009396912
X	-0.424542787	-0.058461262
1	0.087306564	0.014394065

Table 11. Strut Drag Results in Coefficient Form.

STRUT DRAG EXPERIMENT - NSWCCD TOWING BASIN CARRIAGE 2
 NOVEMBER 2001 - "V" STRUTS w/LOWER STRUT FAIRINGS - EXP. 22

VS	CFX (6-Comp Bal)	CTD* (strut drag)
1.0	-0.1918	-0.0338
1.1	-0.1754	-0.0338
2.0	-0.1353	-0.0234
2.0	-0.1214	-0.0235
3.0	-0.1317	-0.0190
3.0	-0.1380	-0.0192
4.0	-0.0905	-0.0179
4.0	-0.0893	-0.0174
5.0	-0.0682	-0.0169
5.0	-0.0698	-0.0169
6.0	-0.0607	-0.0161
6.0	-0.0617	-0.0163
7.0	-0.0580	-0.0155
7.0	-0.0563	-0.0156
8.0	-0.0561	-0.0150
8.0	-0.0572	-0.0152
9.0	-0.0547	-0.0148
9.0	-0.0544	-0.0148
10.0	-0.0535	-0.0146
10.0	-0.0546	-0.0147
11.0	-0.0527	-0.0145
11.0	-0.0528	-0.0146
12.0	-0.0531	-0.0145
12.0	-0.0537	-0.0146
13.0	-0.0524	-0.0144
13.0	-0.0525	-0.0144
14.0	-0.0526	-0.0144
14.0	-0.0531	-0.0145
15.0	-0.0524	-0.0144
15.0	-0.0523	-0.0144
16.0	-0.0522	-0.0144
16.0	-0.0526	-0.0145
16.0	-0.0522	-0.0144
16.0	-0.0517	-0.0144
16.0	-0.0522	-0.0144
16.0	-0.0521	-0.0144
17.0	-0.0515	-0.0143
17.0	-0.0525	-0.0143
18.0	-0.0520	-0.0144
18.0	-0.0529	-0.0144
19.0	-0.0526	-0.0146
19.0	-0.0530	-0.0146
20.0	-0.0544	-0.0154
20.0	-0.0546	-0.0154

This page was intentionally left blank.

APPENDIX A

EXPERIMENTAL PROCEDURES, ACCURACY AND UNCERTAINTY

The open water experiments were performed with the model propulsor in the NAVSURFWARCEN CARDEROCKDIV Carriage 2 Towing Basin. Propulsor rotor shaft thrust and torque were measured with a Kempf and Remmers H 48 dynamometer to the nearest 0.01 lbf (0.045 N) of thrust and 0.25 in-lbs (0.028 N-m) of torque. The accuracy of the rotor shaft thrust and torque readings was ± 0.15 percent. Rotor shaft rate of revolution was measured to the nearest 0.01 revolutions per second using a magnetic pick-up and a gear with 100 teeth. A 620-tooth gear and a magnetic pick-up were used to measure the speed of advance (carriage speed) to the nearest 0.1 ft/s (0.03048 m/s).

Duct, post-swirl stator and lower support strut axial force was measured by two axial force gages designed and built by PSU/ARL. The load capacity of each of these gages was about 155 lbf (689.4 N). The calibration constant for each axial force gage was chosen to give a positive axial load in the forward direction. The uncertainty of the axial force measurements was estimated to be ± 0.60 percent of the sum of the loads measured on both gages. The uncertainty estimate was based on data from in-situ calibrations performed with the gages and hardware installed on the carriage before the test.

Duct, post-swirl stator and strut forces and moments were measured by a 6-component body dynamometer designed and built by Advanced Mechanical Technology Inc (S/N M3623). The 6-component gage can measure up to $\pm 5,000$ lbf ($\pm 22,240$ N) in axial (F_x), side force (F_y) and lift (F_z) forces. Moments up to $\pm 2,500$ ft-lb ($\pm 4,067.5$ N-m) in roll (M_x), $\pm 25,000$ ft-lb ($\pm 33,895.5$ N-m) in pitch (M_y) and $\pm 5,000$ ft-lb ($\pm 2,711.6$ N-m) in yaw (M_z) can be measured by the 6-component gage. The uncertainty of the 6-component gage measurements for each force component is ± 0.08 % (± 4.0 lbf / ± 17.8 N) in F_x , ± 0.12 % (± 6.0 lbf / ± 26.7 N) in F_y and ± 0.33 % (± 16.5 lbf / ± 73.4 N) in F_z . The uncertainty of the moment measurements is ± 0.33 % (± 8.3 ft-lb / ± 11.3 N-m) in M_x , ± 0.12 % (± 30.0 ft-lb / ± 40.7 N-m) in M_y , and ± 0.43 % (± 21.5 ft-lb / ± 29.1 N-m) in M_z . Measurement uncertainty was estimated based on calibrations of the 6-component gage (Modern Machine & Tool Co., Inc., November 9, 1999). The sign convention of the forces and moments acting on the center of the 6-component gage is shown in Figure A-1.

Open water results are plotted as nondimensional coefficients. The experimental uncertainty of these coefficients is approximately 2 percent for measurements made at identical Reynolds numbers.

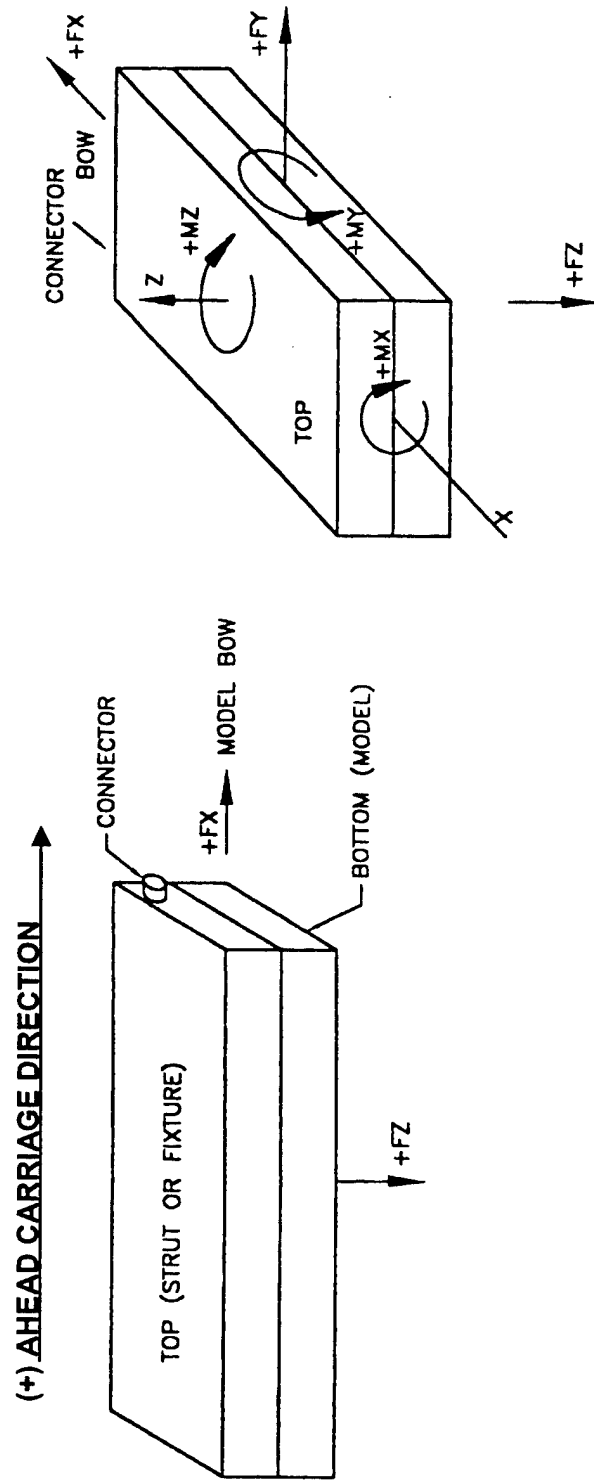

Figure A-1. Drawing of the 6-Component Dynamometer Coordinate System

APPENDIX B

PHOTOGRAPHS OF STRUT SPRAY AND WAVES

Wave and Spray Pictures



4 ft/sec (1.22 m/s)

Figure B-1. Strut Wave and Spray at 4 ft/sec, 0 degrees pitch

Wave and Spray Pictures



8 ft/sec (2.44 m/s)

Figure B-2. Strut Wave and Spray at 8 ft/sec, 0 degrees pitch

Wave and Spray Pictures



12 ft/sec (3.66 m/s)

Figure B-3. Strut Wave and Spray at 12 ft/sec, 0 degrees pitch

Wave and Spray Pictures



16 ft/sec (4.88 m/s)

Figure B-4. Strut Wave and Spray at 16 ft/sec, 0 degrees pitch

Wave and Spray Pictures

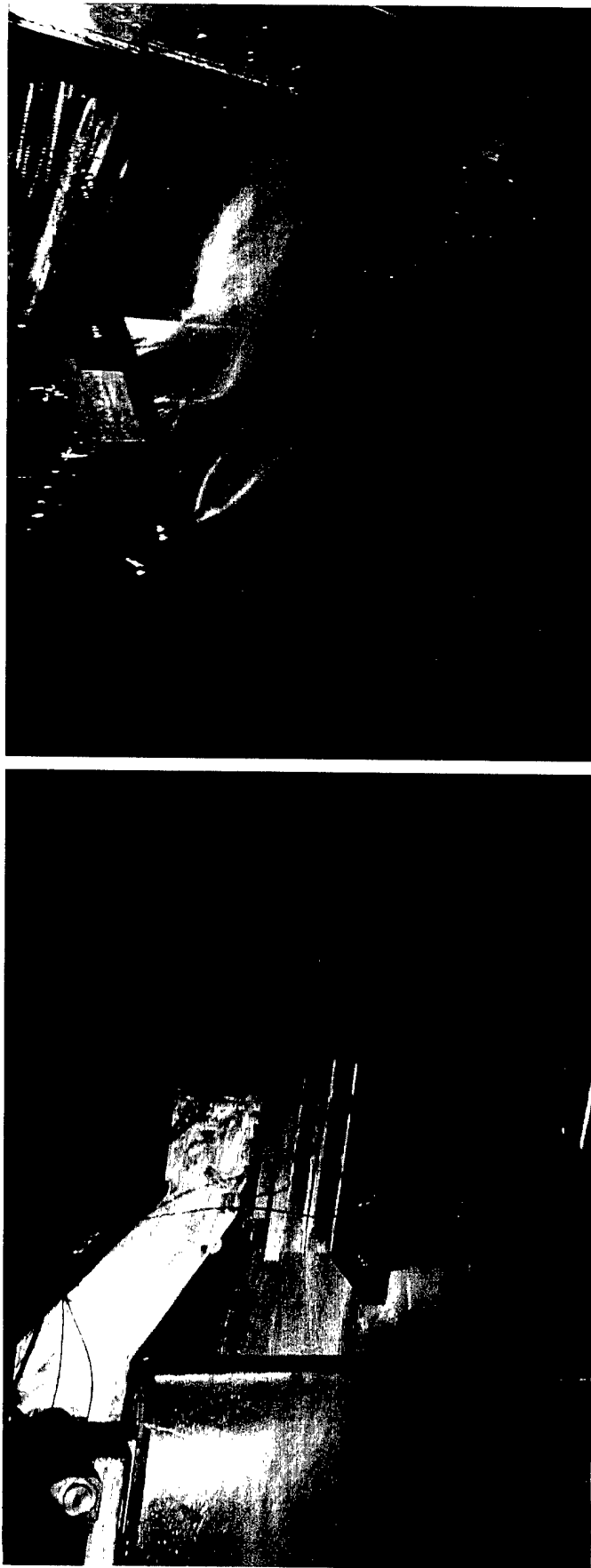

20 ft/sec (6.10 m/s)

Figure B-5. Strut Wave and Spray at 20 ft/sec, 0 degrees pitch

APPENDIX C

FLOW VISUALIZATION PHOTOGRAPHS

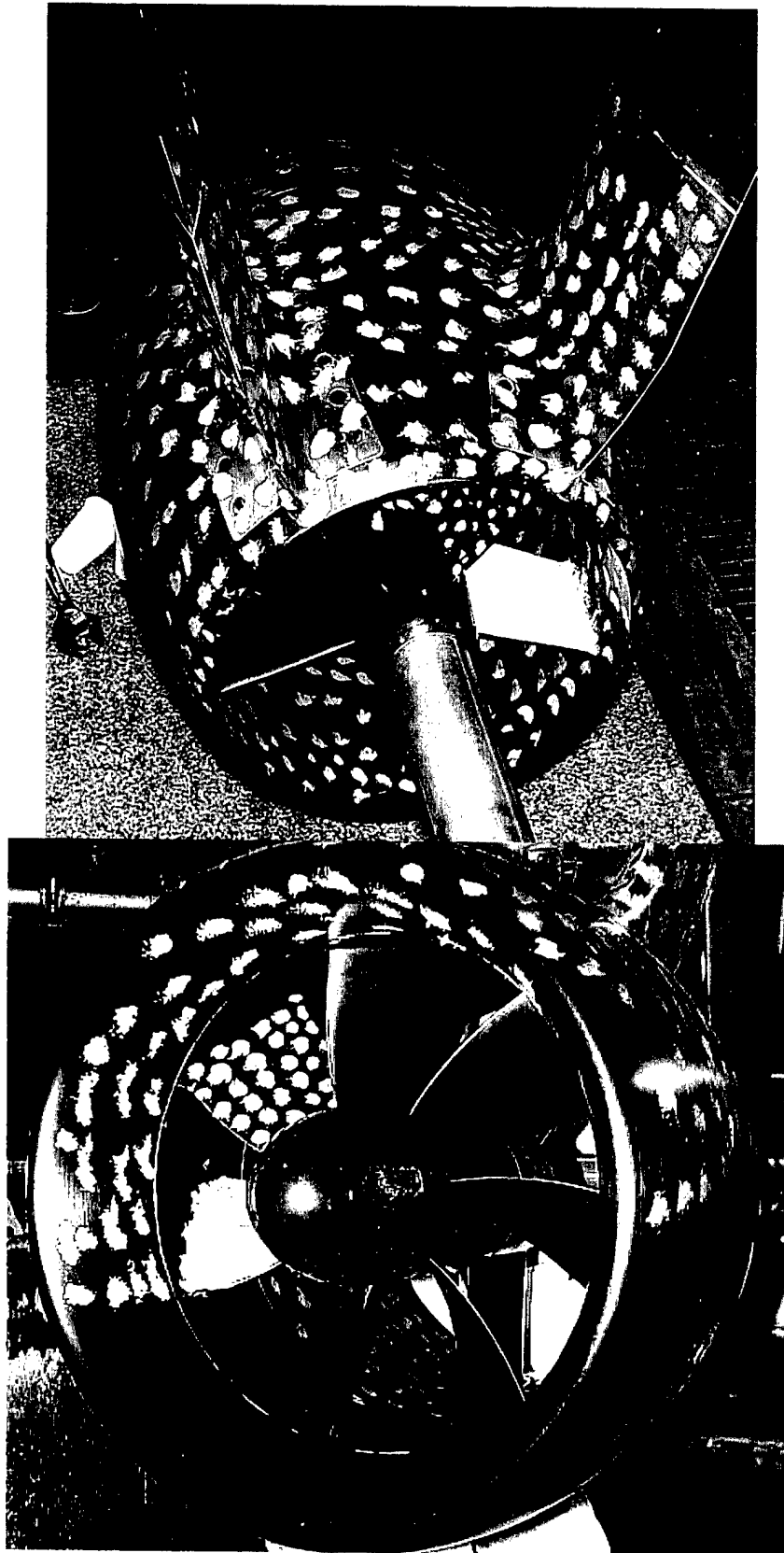

Figure C-1. Paint Applied before the Flow Visualization Run

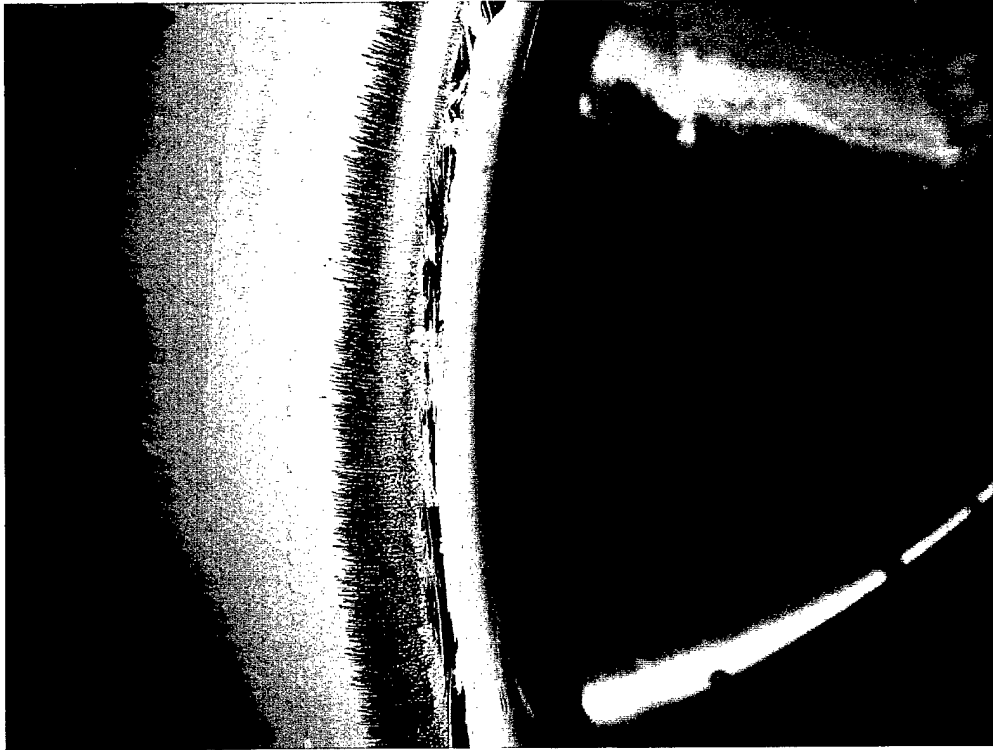

Figure C-2. Paint Flow on the Forward End of the Unit, 0 degrees pitch



Figure C-3. Paint Flow on the Aft End of the Unit, 0 degrees pitch

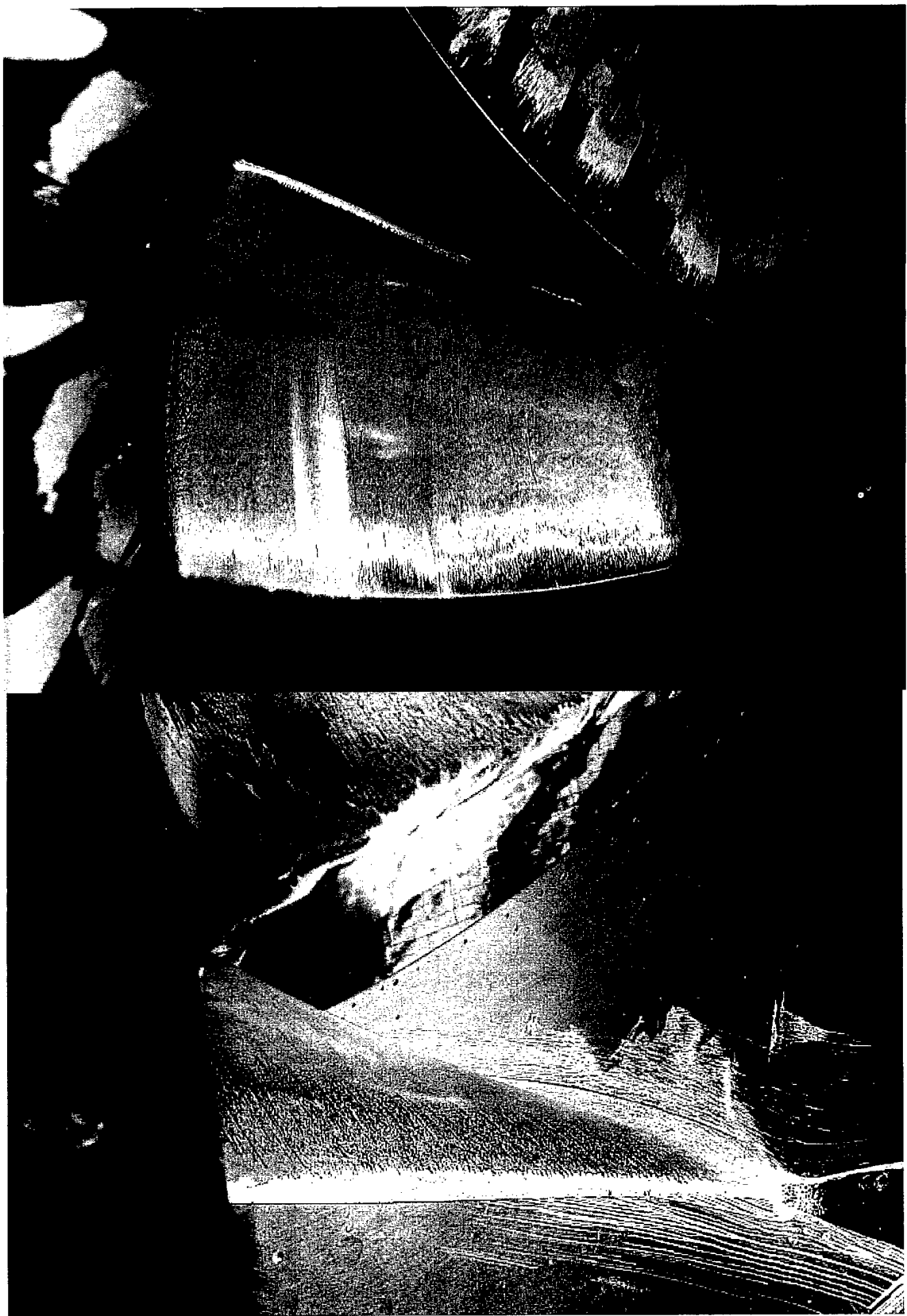

Figure C-4. Paint Flow on the Suction Side of the Rotor Blade, 0 degrees pitch

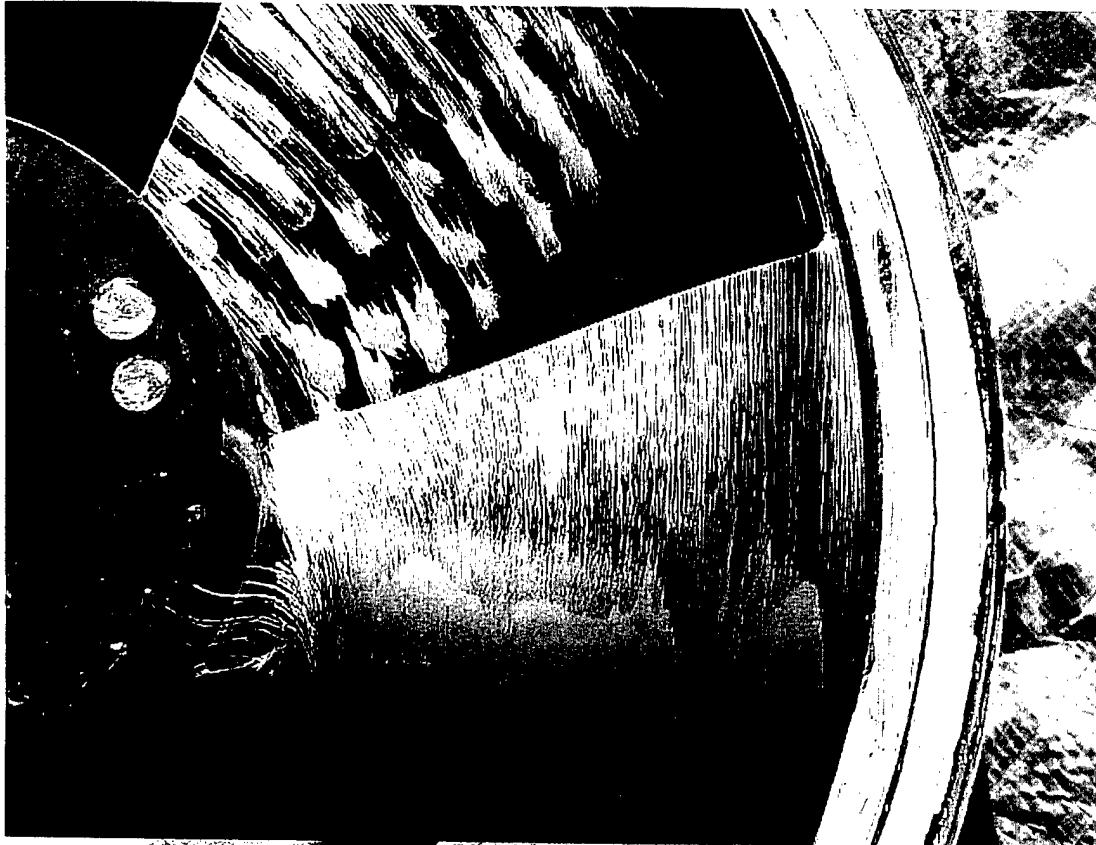

Figure C-5. Paint Flow on the Pressure Side of the Rotor Blade, 0 degrees pitch

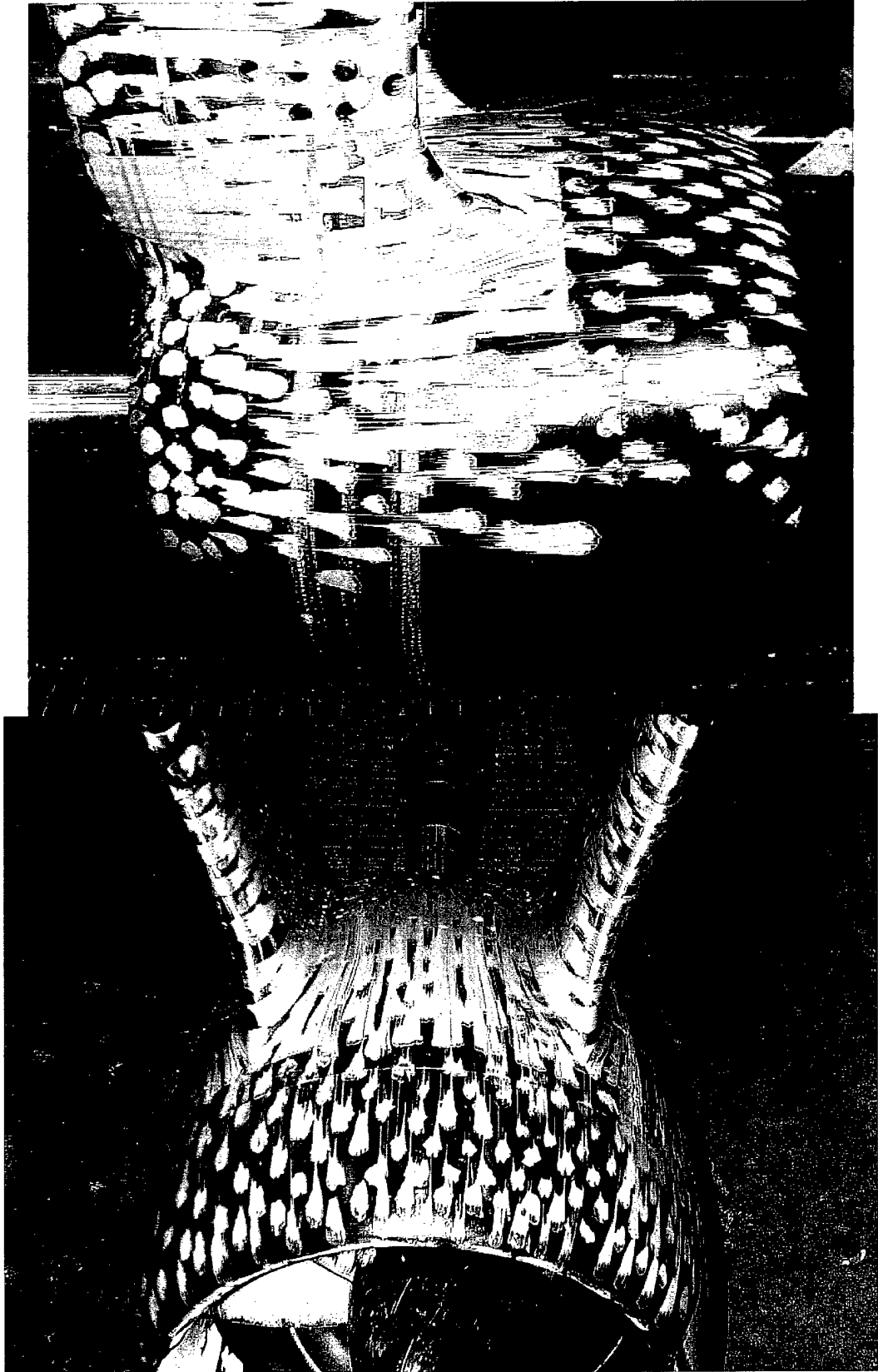

Figure C-6. Paint Flow on the Outside of the Duct, 0 degrees pitch

This page was intentionally left blank.

REFERENCES

1. Michael, Thad J., S. D. Jessup and O. Scherer, "AHFID Propulsor Performance Prediction," NSWCCD-50-TR-2002/003 (January 2002).

This page was intentionally left blank.

INITIAL REPORT DISTRUBITION

ORGANIZATION	NAME	(COPIES)
General Dynamics Electric Boat	M. Quadrini	10
	J. Panosky	1
	C. Knight	1
PSU/ARL	D. Boger	1
	J. Eaton	1
NSWCCD Code 3421	NSWCCD Library	1
Code 506	D. Walden	10
Code 5400	Library	1
Code 5400	K. Anderson	1
Code 5400	C. Borda	1
Code 5400	M. Donnelly	1
Code 5400	T. Michael	1
DTIC		2

This page was intentionally left blank.