



**AN EXAMINATION OF LATENCY AND DEGRADATION ISSUES IN
UNMANNED COMBAT AERIAL VEHICLE ENVIRONMENTS**

THESIS

Shane A. Dougherty, Captain, USAF

AFIT/GOR/ENS/02-05

**DEPARTMENT OF THE AIR FORCE
AIR UNIVERSITY**

AIR FORCE INSTITUTE OF TECHNOLOGY

Wright-Patterson Air Force Base, Ohio

APPROVED FOR PUBLIC RELEASE; DISTRIBUTION UNLIMITED

Report Documentation Page

Report Date 26 Mar 02	Report Type Final	Dates Covered (from... to) May 2001 - Mar 2002
Title and Subtitle An Examination of Latency and Degradation Issues in Unmanned Combat Aerial Vehicle Environments	Contract Number	
	Grant Number	
	Program Element Number	
Author(s) Capt Shane A. Dougherty, USAF	Project Number	
	Task Number	
	Work Unit Number	
Performing Organization Name(s) and Address(es) Air Force Institute of Technology Graduate School of Engineering and Management (AFIT/EN) 2950 P Street, Bldg 640 WPAFB, OH 45433-7765	Performing Organization Report Number AFIT/GOR/ENS/02-05	
Sponsoring/Monitoring Agency Name(s) and Address(es) Unmanned Aerial Vehicle BatteLab 1003 Nomad Way, Suite 107 Eglin AFB, FL 32542-6867	Sponsor/Monitor's Acronym(s)	
	Sponsor/Monitor's Report Number(s)	
Distribution/Availability Statement Approved for public release, distribution unlimited		
Supplementary Notes The original document contains color images.		
Abstract There are two basic ways to control an Unmanned Combat Aerial Vehicle (UCAV) as it searches for targets: allow the UCAV to act autonomously or employ man-in-the-loop control. There are also two target sets of interest: fixed of mobile targets. This research focuses on UCAV-based targeting of mobile targets using man-in-the-loop control. In particular, the interest is in how levels of satellite signal latency or signal degradation affect the ability to accurately track, target, and attack mobile targets. This research establishes a weapon effectiveness model assessing targeting inaccuracies as a function of signal latency and/or signal degradation. The research involved three phases. The first phase in the research was to identify the levels of signal latency associated with satellite communications. A literature review, supplemented by interviews with UAV operators, provided insight into the expected range latency values. The second phase of the research identified those factors whose value, in the presence of satellite signal latency, could influence targeting errors during UCAV employment. The final phase involved developing and testing a weapon effectiveness model explicitly modeling satellite signal latency in UCAV targeting against mobile targets. This phase included an effectiveness analysis study.		

Subject Terms

Unmanned Aerial Vehicle, UAV, Unmanned Combat Aerial Vehicle, UCAV, simulation, ARENA.

Report Classification

unclassified

Classification of this page

unclassified

Classification of Abstract

unclassified

Limitation of Abstract

UU

Number of Pages

55

The views expressed in this thesis are those of the author and do not reflect the official policy or position of the United States Air Force, Department of Defense, or the U.S. Government.

AFIT/GOR/ENS/02-05

AN EXAMINATION OF LATENCY AND DEGRADATION ISSUES IN
UNMANNED COMBAT AERIAL VEHICLE ENVIRONMENTS

THESIS

Presented to the Faculty

Department of Operational Sciences

Graduate School of Engineering and Management

Air Force Institute of Technology

Air University

Air Education and Training Command

In Partial Fulfillment of the Requirements for the
Degree of Master of Science in Operations Research

Shane A. Dougherty, B.A.E.

Captain, USAF

March 2002

APPROVED FOR PUBLIC RELEASE; DISTRIBUTION UNLIMITED.

AFIT/GOR/ENS/02-05

AN EXAMINATION OF LATENCY AND DEGRADATION ISSUES IN
UNMANNED COMBAT AERIAL VEHICLE ENVIRONMENTS

Shane A. Dougherty, B.A.E.
Captain, USAF

Approved:

Raymond R. Hill, Lt Col, USAF (Advisor)

date

Dr. James T. Moore (Reader)

date

Acknowledgments

I would like to thank the members of my thesis committee, Lt Col. Raymond Hill and Dr. James Moore. Their guidance and knowledge have enabled me to maintain my sanity and complete this thesis effort on time. I have thoroughly enjoyed my time at AFIT and my work with them both.

I would like to thank my classmates that have helped me maintain balance in my life while working on this thesis effort. Countless hours of basketball games and numerous card games were the perfect release when frustrations began to mount.

I would like to thank my children whose enthusiasm and innocence was a constant reminder of God's greatest gift. Their unconditional love made the long hours of work and study bearable.

Finally, I would like to thank my wife. Words cannot express how important her love and support has been to me. Her patience and sacrifice are unmatched and without bounds. I love her now and forever.

Shane Dougherty

Table of Contents

	Page
Acknowledgments.....	iv
List of Figures	vii
List of Tables	ix
Abstract	x
I. Introduction.....	1
General Issue	1
Background	1
The Problem.....	2
Research Objectives.....	3
Scope of Research.....	3
Contribution of Research.....	4
II. Literature Review	5
Introduction.....	5
UCAV ACTD Program	5
Command and Control.....	8
Satellite Connectivity.....	11
Bandwidth Requirements.....	13
Dynamic Engineering Equations	14
III. Methodology	16
Introduction.....	16
Assumptions	16
UCAV to Ground Control Station (GCS) Transmission.....	17
Ground Control Station (GCS) to UCAV Transmission.....	19
Jamming Environment	23
Analysis Methodology.....	23
Chapter Summary	23
IV. Results and Analysis	24
Overview.....	24
Scenario One: Constant Velocity, Non-maneuvering Target	24
Scenario Two: Accelerating, Non-maneuvering Target.....	28
Scenario Three: Constant Velocity, Non-Maneuvering Target (w/ Jamming).....	30
Scenario Four: Constant Velocity, Maneuvering Target.....	32
Satellite Connectivity Baselines	34
Chapter Summary	34

V. Conclusions	35
Literature Review Findings	35
Recommendations for Future Research.....	36
Appendix A. ARENA MODEL.....	37
Bibliography.....	42
Vita.....	43

List of Figures

	Page
Figure 1. UCAV Acquisition Strategy (1)	6
Figure 2. Phase I Milestone (1)	6
Figure 3. Boeing X-45A UCAV ACTD	7
Figure 4. Acceptable data time late versus target types (10)	12
Figure 5. Hypothesized Signal Latency to Miss-Distance Relationship	19
Figure 6. Location Designation and Target Relationship	22
Figure 7. Mobile Target Engagement with Constant Velocity (30-second engagement)	25
Figure 8. Mobile Target Engagement with Constant Velocity (60-second engagement)	26
Figure 9. Mobile Target Engagement with Constant Velocity (Latency 2-7 sec)	28
Figure 10. Accelerating Ground Target (2 ft/sec^2), $V_{\text{max}} = 100 \text{ ft/sec}$	29
Figure 11. Accelerating Ground Target (4 ft/sec^2), $V_{\text{max}} = 100 \text{ ft/sec}$	29
Figure 12. Low Level Jamming Engagement	30
Figure 13. Medium Level Jamming Engagement	31
Figure 14. High Level Jamming Engagement	31
Figure 15. Maneuvering Target with Constant Velocity	32
Figure 16. Non-Maneuvering Target with Constant Velocity	33
Figure 17. UCAV to GCS Transmission Algorithm w/o Jamming	38
Figure 18. GCS to UCAV Transmission Algorithm w/o Jamming	39
Figure 19. Target Maneuvering Algorithm	39
Figure 20. Target Update/End Simulation Algorithm	39

Figure 21. Designation Algorithm	39
Figure 22. UCAV to GCS Transmission Algorithm w/ Jamming	40
Figure 23. GCS to UCAV Transmission Algorithm w/ Jamming	40
Figure 24. Jamming Algorithm.....	41

List of Tables

	Page
Table 1. UCAV-GCS Latency Bounds	18
Table 2. GCS-UCAV Latency Bounds	20
Table 3. Avg Miss Distance Variance (Scenario 1, 30-second engagement).....	25
Table 4. Avg Miss Distance Variance (Scenario 1, 60-second engagement).....	27
Table 5. Avg Miss Distance Variance (Scenario 4).....	33
Table 6. Initial Setting Variables	37
Table 7. Boolean Variables (1 = Yes).....	37
Table 8. Global Variables	38

Abstract

There are two basic ways to control an Unmanned Combat Aerial Vehicle (UCAV) as it searches for targets: allow the UCAV to act autonomously or employ man-in-the-loop control. There are also two target sets of interest: fixed or mobile targets. This research focuses on UCAV-based targeting of mobile targets using man-in-the-loop control. In particular, the interest is in how levels of satellite signal latency or signal degradation effect the ability to accurately track, target, and attack mobile targets. This research establishes a weapon effectiveness model assessing targeting inaccuracies as a function of signal latency and/or signal degradation. The research involved three phases.

The first phase in the research was to identify the levels of latency associated with satellite communications. A literature review, supplemented by interviews with UAV operators, provided insight into the expected range latency values.

The second phase of the research identified those factors whose value, in the presence of satellite signal latency, could influence targeting errors during UCAV employment. The final phase involved developing and testing a weapon effectiveness model explicitly modeling satellite signal latency in UCAV targeting against mobile targets. This phase included an effectiveness analysis study.

AN EXAMINATION OF LATENCY AND DEGRADATION ISSUES IN UNMANNED COMBAT AERIAL VEHICLE ENVIRONMENTS

I. Introduction

General Issue

Operations Allied Hope, Desert Shield, and Desert Storm were military operations that showcased the abilities of Unmanned Aerial Vehicles (UAVs). UAVs provide intelligence, surveillance, reconnaissance, and command and control information to Allied commanders in real-time or near real-time format. The success of UAVs raised the question about future roles for UAVs in military operations. These roles include weaponization of UAVs and the use of UAVs for designation, grouped commonly as Unmanned Combat Aerial Vehicles (UCAVs). A concern with UCAVs is the potential impact of time-delays or signal interruptions on UCAV to ground control unit (GCU) communications and interactions. This research quantifies the potential impact of signal disruption and interruption on UCAV mission capability. A prototype ARENA simulation model is defined, built, and used to quantify the effect of latency on an expected UCAV mission.

Background

Typical UCAV missions could be the attack of heavily defended high value targets, active Suppression of Enemy Air Defenses (SEAD), and target designation for standoff precision guided munitions. The use of UAVs in a combat role is not a new idea. The Israeli military has already used UAVs in actual combat. The Israelis used

Electro-Optical seeking Maverick missiles attached to AQM-34 Lightning Bug drones to attack Soviet-built Egyptian air defenses in the Bekka Valley. This tactic was successful in the 1970s, because the Surface-to-Air Missiles (SAM) systems continued electro-optical emissions while actively seeking targets. Due to changes in system hardware and tactics, Surface-to-Air Missile (SAM) systems no longer continually emit electromagnetic energy. SAM system attacks now require TV-guided, laser-guided, or gravity munitions. If the targets are mobile, the n interruptions between the UCAV and satellites or ground control units controlling the UCAV can become an issue. The source of these interruptions range from the time a signal takes to travel from a UCAV to GCU and back, commonly referred to as latency, to possible signal denial via adversary jamming.

The Problem

Little, if any, work has quantitatively examined how critical a signal time delay may be in operator-controlled UCAV missions. We want to provide such an examination. Thus, we ask, what is the impact of satellite latency and signal degradation on the mission capability of the Unmanned Combat Aerial Vehicle? The true value of UCAVs lie in their ability to effectively perform those tasks deemed too dangerous for manned flight. While autonomously guided weapons, like cruise missiles, already perform similar missions, they lack the ability to attack highly mobile targets or “targets-of-opportunity”. The UCAV provides a means to designate a target, such as with a laser designator, while a precision-guided munition, fired outside any lethal range of enemy systems, hones in on the UCAV-maintained designation.

Research Objectives

The objective of this research is to develop and employ a methodology for quantifying the effects of control signal latency for the UCAV target designation mission. Part of this process is to develop an ARENA simulation model to examine latency issues. The first step is to identify the expected levels of satellite latencies accounting for degradation effects due to jamming and loss of satellite coverage. For this research, these are identified through review of current literature and interviews with Air Force satellite operators, weapons system operators, and UCAV pilots. Next, the latencies levels are input into the ARENA model to ascertain the amount of potential designation or weapon impact position error as a function of latency and degradation. The intent is to help UCAV operators determine potential mission effectiveness in various theaters of operation.

Scope of Research

This research is limited to current and planned satellite constellations and UAV communication capabilities. Within the satellite constellations, research is limited to those most likely to be used by theater UAVs.

This research is limited to latency issues resulting from transmission via satellites and from degradation effects and how they affect the UCAVs' ability to target a mobile target. Our measures are precision munitions miss distances only. We do not model probability of kill as a function of miss distance.

Contribution of Research

To the best of our knowledge, the effects of latency have yet to be quantified other than notionally. This study provides background on latency and an ARENA model for assessing UCAV combat capability while experiencing various levels of latencies. Our hope is that this knowledge will allow Air Force senior leaders to make more educated decisions on the UCAVs' combat effectiveness under various operating conditions.

II. Literature Review

Introduction

This chapter provides a thorough review of the literature relevant to this research effort. Initially, we provide a current description of the Defense Advanced Research Projects Agency funded UCAV Advanced Concept Technology Demonstration (ACTD). Then we present the type of command and control structure that could be used by a UCAV, specifically addressing the autonomous and man-in-the-loop control methods. We then review current satellite orbitology and bandwidth requirements associated with UCAV systems. Finally, we review the dynamic engineering equations used to determine the distance between a mobile target and the UCAVs laser designation when latency or signal degradation exists.

UCAV ACTD Program

In March of 1998, the Defense Advanced Research Projects Agency, in conjunction with the U.S. Air Force, released a UCAV ACTD solicitation. The purpose of the ACTD was to aid decision-makers in determining whether or not it was technically feasible to continue development of a UCAV system. The primary objective of the UCAV ACTD was to design, develop, integrate, and demonstrate the targeting/weapons delivery, air vehicle design, human-systems interactions, command, control, and communications critical technologies pertaining to an operational UCAV system (1).

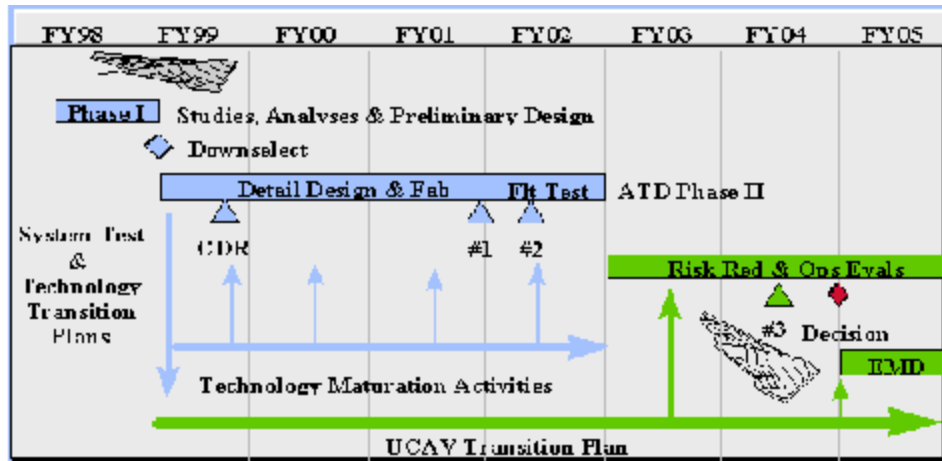

Figure 1. UCAV Acquisition Strategy (1)

The UCAV ACTD was divided into two phases (Fig 1.) where Phase II was conditioned upon positive results from Phase I. Phase I was a 10-month trade study, analyses, and preliminary design phase with \$4M in contracts awarded to four different contractor teams. In April 1998, DARPA selected Lockheed Martin Tactical Aircraft Systems; Northrop Grumman Corporation, Military Aircraft Systems Division; Raytheon Co., Raytheon Systems Co.; and The Boeing Company, Information, Space & Defense Systems, Phantom Works as contractor team leads (2).

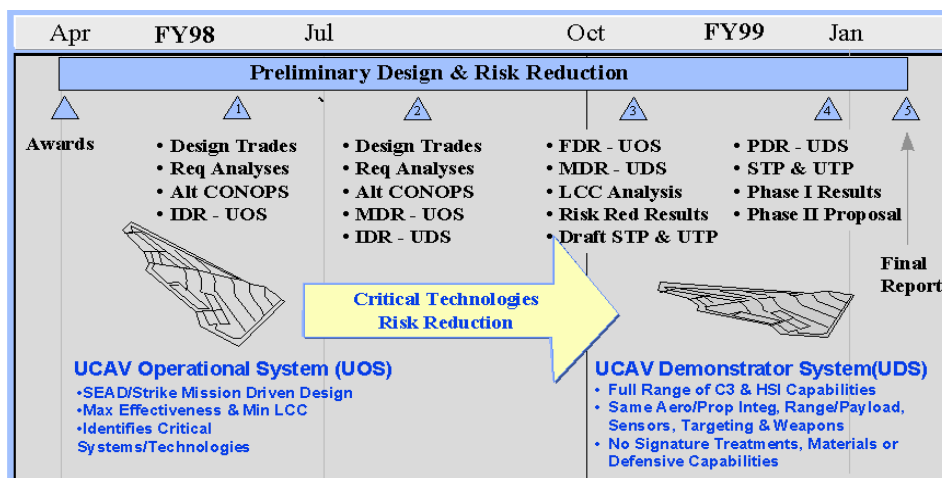

Figure 2. Phase I Milestone (1)

Phase I (Fig 2.) culminated with the decision to proceed to Phase II. Phase II is a 42-month phase, worth approximately \$131M, awarded in March 1999 to The Boeing Company contractor team to develop, fabricate, and flight test demonstrator vehicles and a mission control station (3). Boeing will develop and build two 27-ft-long, tailless UCAVs (see Fig 3.) with 34-ft wingspans that exploit real-time on-board and off-board sensors to detect, identify and locate both fixed and mobile targets (8). In addition, Boeing will also develop a reconfigurable mission control system with line-of-sight and satellite relay communications links.



Figure 3. Boeing X-45A UCAV ACTD

Command and Control

A critical UCAV operational issue is what degree of autonomy should be used to control a UCAV system. The degree of autonomy used is a function of the level of technological maturity (9). According to Major General Kostelnik, Air Armament Center (AAC) Commander, “the technologies that will make UCAVs capable in the future are not hardware technologies. They are not airfoils, engines, or weapons. We have those technologies at our fingertips. The challenge lies in the software. It’s all about connectivity and C²” (9). Current UCAV literature identifies two methods of UCAV control: fully autonomous control or remotely piloted (man-in-the-loop) control.

Autonomous Control

A totally autonomous command and control structure is fully reliant on its own systems, such as automatic target recognition (ATR), to make engagement decisions (9). As the degree of UCAV autonomy increases, a UCAV system must possess an increased capability to sense changes in its environment and make appropriate decisions (4). The combination of on-board sensors, control and analysis software, and pattern recognition software that gives UCAVs the ability to think for themselves is often referred to as their “wetware” (7).

The question surrounding the development of “wetware” type of machine intelligence is how to ensure UCAVs make and learn the appropriate lessons in the presence of the fog and friction of warfare. The ability of “wetware” to compensate for all uncertainties is analogous to the idea of totally replacing flight-testing with simulation techniques. For example, simulation-based technology advocates have continually

expressed the opinion that with the advancement in simulation techniques, actual flight-testing is no longer required. However, flight-testing continues today, albeit at a diminished level, to identify those unknown interactions not accounted for or even recognized by the software designers. A UCAV will ultimately function based upon the software designed by computer engineers and the engineers ability to design the software to handle all possible contingencies.

Humans are by their nature intuitive creatures that can assimilate incomplete, conflicting, and confusing information and still produce reasonable courses of action (5). It is this skill and experience that the UCAV “wetware” seeks to replace. The question is whether or not computer coding can exhibit the reasoning and cognitive capabilities of an experienced combat pilot (6)? In addition, will this wonderous software package have the requisite reliability and maintainability attributes? Finally, are we willing to let software (in the UCAV) cause potential fratricide and missed targeting given these events still occur with fully manned systems?

One of the benefits of an autonomous UCAV is the lack of a data-link required to support command, control, and communication (7). The data link will still exist to unload mission changes to the UCAV; however, the data link is no longer directly tied to mission success. This reduces the UCAV vulnerability to data-link jamming effects because as the degree of autonomous control increases, the need for two-way directional communications and data-transfer decreases (4).

Man-in-the-Loop (MITL) Control

Like autonomous UCAVs, man-in-the-loop (MITL) systems have their own problems and benefits. A MITL controlled UCAV requires a two-way communications/data-link. The data link relays signals from the UCAV's sensors to the remote controller who then returns instructions to the UCAV (4). This can limit UCAV operations as the telemetry signals for each UCAV/controller combination must be unique, and satellite bandwidth availability limits the number of simultaneously operated UCAV aircraft (7).

The first problem with MITL UCAV is the requirement for a data-link transmission. Data-link or radio-control transmissions are vulnerable as there is no such thing as a jam-proof data-link (5,7). The adversary's jamming effort could occur at the most critical engagement moment – aiming and delivering ordnance (5). The enemy only needs to jam the data-link for a few seconds, possibly even milli-seconds, to produce profound, and negative effects (5). The impact of this disruption of the data-link (modeled in the form of a latency) is one of the areas of analysis addressed in this research.

A second problem with MITL UCAV is the bandwidth requirements in an area of operations. A satellite link is viewed as a possible solution to the difficulty imposed by the transmission of large quantities of data over existing communication technologies (5). The satellite impacts and bandwidth requirements for MITL UCAV operation are discussed later in this literature review.

The worst scenario is an adversary jamming our signals and then taking control of the UCAV. Unfortunately, this scenario has actually been realized albeit not in a UCAV

scenario. A data-link controlled EOD (explosive ordinance disposal) robot was turned against its operator. While the robot was disarming a bomb, the bomber successfully jammed and replaced the police signal controlling the robot and then directed the robot at the officers that were originally controlling the robot (7). We mention this worst-case scenario but exclude its impact from our analysis.

The risk of temporary, partial, or total interruption in the data-link between the UCAVs and mission control system must be evaluated when assessing the level of autonomy associated with UCAV employment. Developing secure, over-the-horizon, anti-jam data-links is likely crucial to the future effectiveness of UCAVs (9).

Satellite Connectivity

A tolerable level of latency for targeting data depends significantly upon the target type, as shown in the notional chart in Figure 4 (10). Relocatable targets require timely targeting, varying from hours to minutes, while moving targets require precise targeting, varying from seconds to milliseconds. One significant factor that actually influences the amount of latency is the location of the orbit of the satellite constellation being used.

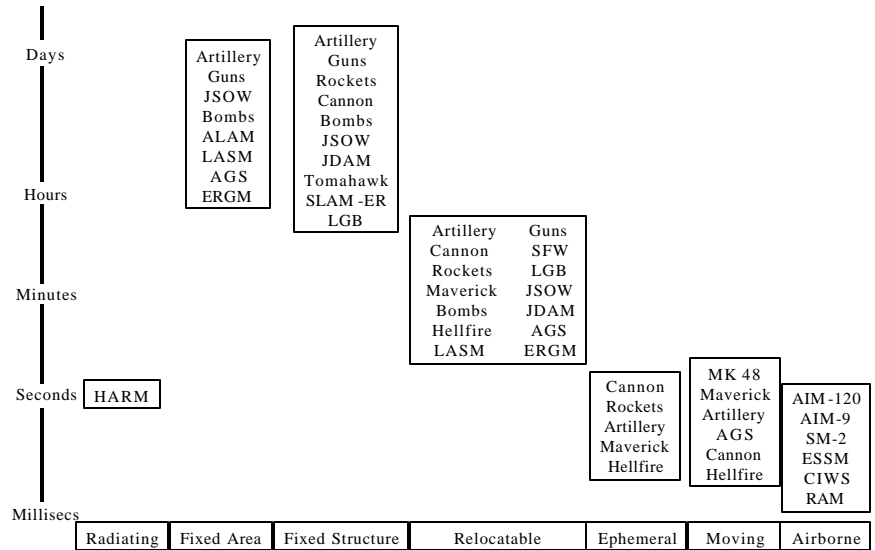

Figure 4. Acceptable data time late versus target types (10)

Geosynchronous Earth Orbit (GEO)

Geosynchronous Earth Orbit is a stationary orbit located about 22,241 miles above the earth’s equator (11). Satellite constellations in GEO provide communications coverage over a majority of the earth’s surface using just a few satellites. However, due to the large distance a signal must travel, these satellites have a minimum 0.24 second signal latency (11). This level of latency may or may not be acceptable to a MITL UCAV engagement against moving targets. In addition, geosynchronous satellites cannot provide full coverage to the northern and southern hemispheres. Finally, because GEO orbits are stationary, there is a limit to the number of satellites that can maintain this orbit, although geosynchronous satellites are relatively easy to track.

Medium Earth Orbit (MEO)

Medium Earth Orbit (MEO) is an orbit located from 6,250 to 12,500 miles above the earth’s surface (11). Unlike GEO, MEO can cover the entire surface of the earth

because their relative position in the sky changes with time. However, for full coverage of the earth, more satellites are required than with a GEO. The advantage of MEO over GEO is that minimum signal latency is reduced from 0.24 seconds to the 0.06 – 0.14 second range (11). Again this level of latency may or may not be acceptable to a MITL UCAV engagement against moving targets. In addition, because of their position changes with time, medium earth orbit satellites are not always in position to support combat operations.

Low Earth Orbit (LEO)

Low Earth Orbit (LEO) satellites normally orbit less than 3,150 miles above the earth's surface, with the majority in the 400 – 1,000 mile range (11). In terms of latency, LEO satellites are most suitable for MITL UCAV engagements because the inherent latency is measured in hundredths of seconds (11). However, whether or not this level of latency is still unacceptable has not been determined. Similar to MEO, LEO requires a large number of satellites to provide continuous coverage over the entire surface of the earth. Additionally, the constellations fault tolerance, the ability to successfully operate when a percentage of the constellation malfunctions, for low earth orbit satellites, is quite large. For example, computer modeling of the Iridium constellation, with only 45 percent of the satellites operational, resulted in communication delays never exceeding 178 milliseconds (11).

Bandwidth Requirements

In the envisioned high-tech combat operations of the future, the amount of bandwidth available for UCAV operations may be limited and thus a concern. The

transmission of analysis quality target pictures significantly expands the amount of data that occupies available bandwidth (9). If the data-link system gets overloaded, it may result in transmission delay (latency) or even shut down (9).

With increasing autonomy, UCAV demands for data-link capacity and thus bandwidth will decrease. Thus, for a full autonomous UCAV with human-like cognitive and reasoning ability, the requirement for data-link bandwidth is no more than a manned combat aircraft (6). However, if some MITL control is present, it is reasonable to assume that necessary video transmissions would greatly increase the bandwidth requirements, especially if multiple UCAVs are operating simultaneously within close proximity. With poor compression techniques, bandwidth requirements will typically be on the order of tens of Megabits per second (6). In addition, this bandwidth requirement can grow to the order of 10 GHz per UCAV when employing a spreading ratio for signal modulation in a jamming environment (6).

“Such bandwidth requirements are arguably not implementable over satellite microwave links, given the established antenna and transmission technology base, and the need for both redundancy and the concurrent support of multiple UCAVs in a given area of operations” (6).

Dynamic Engineering Equations

In order to ascertain the precision munitions miss distance, it is necessary to use several dynamic equations relating location with speed, acceleration, and direction.

The distance a mobile target travels per unit time is a function of its speed. When the target is moving with a constant speed, the distance covered is given by the speed times time.

$$\text{DISTANCE} = \text{SPEED} * \text{TIME} \quad (2.1)$$

When the speed of the target is non-constant, the target has an acceleration (deceleration) component. Acceleration is the change in speed (final – initial) divided by the length of time required for the speed change. If the change in speed is negative (positive), the target is decelerating (accelerating).

$$\text{ACCELERATION} = \frac{(\text{FINAL SPEED} - \text{INITIAL SPEED})}{\text{TIME}} \quad (2.2)$$

When the target's acceleration is constant, but the speed is non-constant Eq. 2.1 is changed slightly. The distance traveled is the average speed (Eq. 2.3) times time.

$$\text{AVERAGE SPEED} = \frac{(\text{INITIAL SPEED} + \text{FINAL SPEED})}{2} \quad (2.3)$$

By combining the above equations, it can be shown that the distance traveled is:

$$\text{DISTANCE} = \text{INITIAL SPEED} * \text{TIME} + \frac{1}{2} * \text{ACCELERATION} * \text{TIME}^2 \quad (2.4)$$

In the next chapter, these equations are used in the development of a UCAV latency model.

III. Methodology

Introduction

The purpose of this research is to develop and implement a methodology for quantifying the effects of signal latency on UCAV targeting effectiveness. An ARENA discrete-event simulation model was designed, built and tested, and used to demonstrate the methodology. The ARENA model captured latency effects in the UCAV to GCS two-way signal and control link. This chapter discusses the particulars of modeling the communication links and the specifics of the study demonstrating the methodology.

Assumptions

Several assumptions were required in order to simplify the UCAV laser designation scenario. The first assumption is that the lasing of the mobile ground target is always successful. The model does not account for different levels of laser returns based upon angles of incident and whether or not the laser is actually on the target. Another assumption involving the laser designation is that once the designator is turned on, it stays on. A third assumption assumes that the GCS operator's cueing data once received, is instantaneous and 100% accurate in relation to a desired weapon impact point. We assume perfect designator accuracy given a specific GCS command. Additionally, the effects of any terrain elevation or location were assumed to be negligible. We do not model bandwidth effects, or picture quality to GCS. The Arena model also does not account for weapon delivery altitudes, type of weapon, seeker gimble limits, or a weapons' ability to make last second corrections to strike a target at the laser designation point.

UCAV to Ground Control Station (GCS) Transmission

The ARENA model simulates the transmission of video from the UCAV to the GCS as snap shot pictures of a mobile ground target. The GCS operator is attempting to designate that mobile target in order to deploy a precision guided munition. The GCS operator designation command is based on the picture presented on the workstation

Frequency of Transmission

The video transmission from the UCAV to the GCS is actually a continuous process. Within ARENA, the process is discretized. The trade-off in this discretization process is modeling fidelity versus computing speed. We model a picture transmission every 0.001 seconds, as this provided a reasonable level of run-time and model fidelity.

Delivery of Transmission

Two factors help determine whether or not the GCS receives the transmitted pictures from the UCAV. These factors are the latency of the signal and whether the signal is jammed or lost.

The effects of signal latency are examined across a full range of latency levels. Because no specific data currently exists dictating how to model satellite latency, we chose 6 latency bands. The lower and upper bounds for each band are shown in Table 1. Each band was used in a simulation scenario with actual latencies modeled as uniformly distributed within the latency band.

Table 1. UCAV-GCS Latency Bounds

Sets	Lower Bound (sec)	Upper Bound (sec)
Set 1	0.0001	0.0005
Set 2	0.001	0.005
Set 3	0.01	0.05
Set 4	0.1	0.5
Set 5	1	5
Set 6	10	50

The latency time for each signal determines delivery time from sender (UCAV or GCS) to receiver (GCS or UCAV). For example, if Picture A was sent by the UCAV at the 10-second mark of the simulation, and this picture has a 4-second latency, the GCS would receive Picture A at the 14-second mark. However, since the actual latencies are random variables it is possible for subsequent picture deliveries to occur out of sequence. For example, if Picture B was sent at the 11-second mark with a 2-second latency, the GCS would receive Picture B at the 13-second mark. This is one second before Picture A arrives at the GCS, which we deem impossible. To solve this problem, if a picture is scheduled to arrive prior to a preceding picture, the picture is considered lost (Picture B in this example). Additionally pictures sent, or currently delayed, when the link between the UCAV and GCS is lost or jammed, are also considered lost.

Perceived Versus Ground Truth

The concern with signal latency during UCAV targeting missions is targeting error due to a disconnect between perception (what the operator sees as a target location) and truth (what is the actual target location). Any signal delay means the operator is effectively viewing the past (not the present). The ARENA model tracks ground truth

(actual target location) and operator perception. A UCAV designator is pointed based on operator commands. Final miss distances are calculated based on ground truth and GCS-commanded target designation locations. The research hypothesis is that latency increases the difference between ground truth and operator perception and this equates to increased weapons miss distances at impact (see Fig 5).

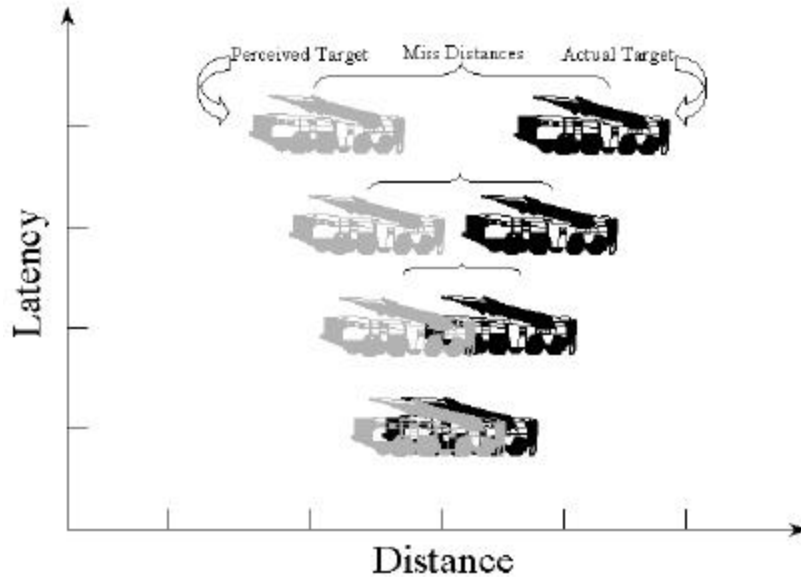

Figure 5. Hypothesized Signal Latency to Miss-Distance Relationship

Ground Control Station (GCS) to UCAV Transmission

The ARENA model also simulates the transmission of GCS command data for a laser designator mounted on the UCAV. The GCS operator is attempting to center the designator on the mobile target. The GCS operator designator centering commands are based on coordinates corresponding to the view in the GCS system (the operator perception).

Frequency of Transmission

The command data transmission from the GCS to the UCAV is discretized in the same manner as previously discussed for the video transmission. However, the GCS does not actually begin transmitting designation command information until the time to turn the designator on has been reached and a transmission has been received from the UCAV.

Delivery of Transmission

Latency and jamming effect control data transmission just as it effects video transmissions. However, bandwidth requirements for control data are less than required for video transmission. Thus the latency bands considered are different than those used for the UCAV-to-GCS link. These bands are provided in Table 2. There are also two important differences when modeling the GCS-to-UCAV link.

Table 2. GCS-UCAV Latency Bounds

Sets	Lower Bound (sec)	Upper Bound (sec)
Set 1	0.00001	0.00005
Set 2	0.0001	0.0005
Set 3	0.001	0.005
Set 4	0.01	0.05
Set 5	0.1	0.5
Set 6	1	5

The first difference is the scenario time must be greater than our equal to the desired time for designating. For example, the majority of engagements using a laser designator actually do not begin “lazing” a target until the final portion of the attack. This minimizes a target’s ability to take defensive measures after being warned by a

laser-warning receiver. Our Arena model runs 30 second engagement scenarios with designating commencing in the final 10 seconds of the engagement.

The second difference is that the UCAV must receive a transmission from the GCS in order to designate. There are two ways for the UCAV not to receive the designation command: the link is lost (jammed) when the transmission is sent or while the transmission is being delayed (GCS-UCAV latency factor). If the UCAV never receives a transmission from the GCS, the laser designator on the UCAV is never turned on by the GCS command.

Laser Designation Location

The scenario associated with determining the location designated by the GCS is depicted in Figure 6. The black tank is used to depict an actual target, while the gray tank symbolizes the location of the target as displayed in the GCS. The first segment (6a) shows the UCAV transmitting the actual target location to a satellite. The second segment (6b) shows the delivery of the UCAV transmission to the GCS monitor, and the GCS designation point (depicted by the cross-hair on the monitor). Because the signal from the UCAV to the GCS is delayed (due to latency), 6b shows the disconnect between the actual target and the target seen by the GCS. The final segment, Figure 6c, shows the UCAV designating the location specified by the GCS operator. Again due to latency, there is a disconnect between the actual location designated (depicted by white cross-hair) and GCS displayed designation location. The over-all miss-distance between the actual target and the location designated has two components. The first component is the difference between the actual target location and the target location perceived by the

GCS. The second component is the difference between the displayed designation location on the perceived target and the actual designation location.

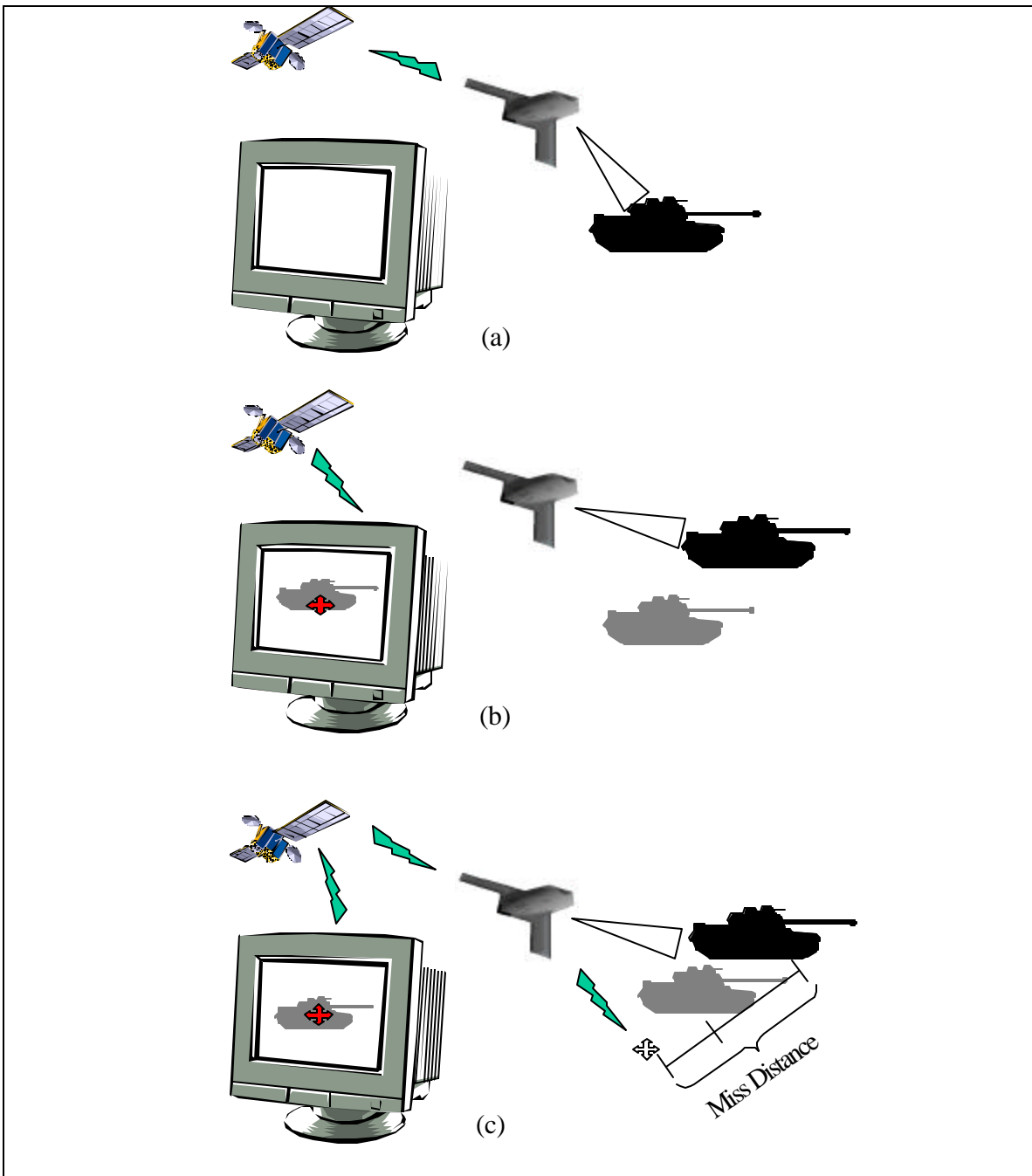

Figure 6. Location Designation and Target Relationship

Jamming Environment

In addition to the standard latency between the UCAV and GCS transmissions, the ARENA model simulates three jamming environments. These three levels are low, medium, and high. The percentage chance of loss of transmission for each level is randomly assigned. The low level has a 0 – 33% chance of signal loss, while the medium level has a 33 – 66% chance of signal loss. Finally, the high level has a 66 – 100 % chance. The value assigned to each jamming level is arbitrary since no data was found related to UCAV jamming environments. If a transmission is lost due to jamming, the ARENA model also determines how long the transmission is lost.

Analysis Methodology

ARENA results are miss distance statistics for each latency and jamming level examined. These data are plotted to produce latency versus miss distance plots and the data is analyzed to assess statistical significance between mean miss distances. Additional modeling is used to hone in on those segments of the resulting latency versus miss distance plot deemed of interest. Targets move at either constant speed or accelerate to some maximum speed.

Chapter Summary

This chapter explained the basic underlining methodology used in an Arena model to simulate the impact that satellite latency and transmission loss has on UCAV laser designation employment. A description of the ARENA model is found in Appendix A. The next chapter presents simulation results and their analysis.

IV. Results and Analysis

Overview

This chapter describes the results associated with four different engagement scenarios. The first scenario involves a non-maneuvering ground target moving at constant velocity in a jam-free environment. The second scenario, also in a jam-free environment, involves an accelerating ground target. The third examines the potential effects of jamming on engagement accuracy against a non-maneuvering ground target. The fourth scenario involves a ground target, in a jam-free environment, which randomly changes direction every 5 seconds. Each scenario is replicated 100 times at each latency setting. Latency is modeled as a discretized process. We examine average latency levels of 0.0003, 0.003, 0.03, 0.3, 3, and 30 seconds. Although we realize latencies around 30 seconds are operationally unacceptable, these levels were used to primarily bound the process and provide insight. Actual tabulated data for the figures in this section can be found in Appendix B.

Scenario One: Constant Velocity, Non-maneuvering Target

Both signal latency and ground target velocity impact potential targeting miss distance. These relationships are direct and linear in logarithmic form.

Figure 7 depicts, on log scale, the average miss distance as a function of signal latency for each target ground speed modeled. As expected, target ground speed directly influences miss distance – higher speeds mean larger differences. As expected, near real time latency translates to very low miss distances (less than a foot). The implication is clear; minor signal problems mean poor targeting accuracy resulting in inaccurate bombs.

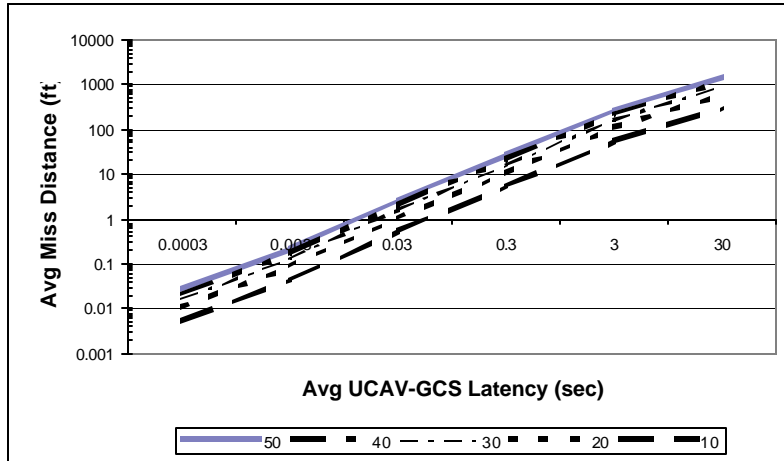

Figure 7. Mobile Target Engagement with Constant Velocity (30-second engagement)

Latency and target velocity also influences the miss distance distribution. Since signal latency is modeled as a random variable with a specified mean, the miss distance is also a random variable. For very low signal latency there is nearly zero variance. However, as seen in Table 3, the variance of observations increases as latency and ground target speed increases. This is expected as both parameters introduce greater levels of uncertainty into the model scenario.

Table 3. Avg Miss Distance Variance (Scenario 1, 30-second engagement)

Latency (sec)	Velocity (ft/s)				
	50	40	30	20	10
0.0003	0.000030	0.000019	0.000011	0.000005	0.000001
0.003	0.002475	0.001584	0.000891	0.000396	0.000099
0.03	0.046257	0.029604	0.016652	0.007401	0.001850
0.3	0.621548	0.397791	0.223757	0.099448	0.024862
3	7.097151	4.542176	2.554974	1.135544	0.283886
30	0.000676	0.000432	0.000243	0.000108	0.000027

At the lower latency levels (milli-second range), the variance of the miss distance is quite small regardless of the target speed. For instance, at the 0.0003-second latency level, the miss distance is 0.00003 and 0.000001 ft for target velocities of 50 and 10 ft/s,

respectively. Table 3 indicates a dramatic decrease in the variance when the average satellite latency increases from 3 to 30 seconds. However, the decrease in variance is not due to an improved process capability, but a result of the scenario length combined with the large average satellite latency. With a 30-second average satellite latency, a large number of the 30-second scenarios end before the GCS receives a single picture. The end result is a decrease in the variance.

60-Second Simulation

To gain additional insight on the 30-second simulation length, we examined the impact from increasing the scenario length to 60 seconds. Figure 8 depicts, on log scale, the average miss distance as a function of signal latency for each target ground speed modeled. As expected, the length of scenario does not significantly change the overall average miss distances except when the average satellite latency is 30-seconds.

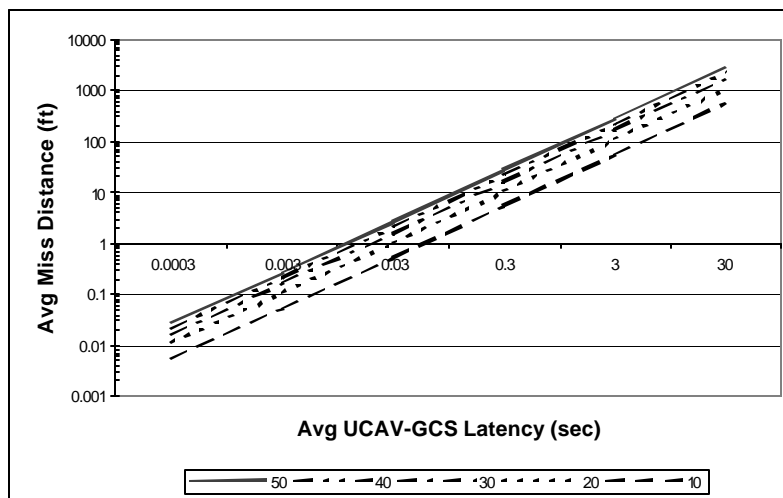

Figure 8. Mobile Target Engagement with Constant Velocity (60-second engagement)

Table 4. Avg Miss Distance Variance (Scenario 1, 60-second engagement)

Latency (sec)	Velocity (ft/s)				
	50	40	30	20	10
0.0003	0.000048	0.000031	0.000017	0.000008	0.000002
0.003	0.003126	0.002001	0.001125	0.000500	0.000125
0.03	0.058316	0.037322	0.020994	0.009331	0.002333
0.3	0.545407	0.349060	0.196346	0.087265	0.021816
3	5.861970	3.751661	2.110309	0.937915	0.234479
30	61.153673	39.138351	22.015322	9.784588	2.446147

As expected, with a 30-second satellite latency, the average miss distance increased for a 60-second simulation because the target has more time to move and the GCS receives few position updates. Table 4 shows that the variance of observations expands as latency and ground target speed increases. As expected, we did not have a decrease in variance, similar to Table 3, when the average satellite latency increased from 3 to 30 seconds. Since the simulation length increased from 30 to 60 seconds, the GCS does receive a few picture updates, which was not the case for the 30-second simulation.

Focused Latencies

To gain a better understanding on the average miss distance in the 1 to 10 second latency range, we examined average latency levels of 2, 3, 4, 5, 6, and 7 seconds.

Figure 9 depicts the average miss distance as a function of signal latency for each target ground speed modeled. As expected, the relationship is still linear in form where target ground speed directly influences miss distance – higher speeds mean larger differences. The implication is clear; full second signal delays result in inaccurate bombs even for slow moving targets.

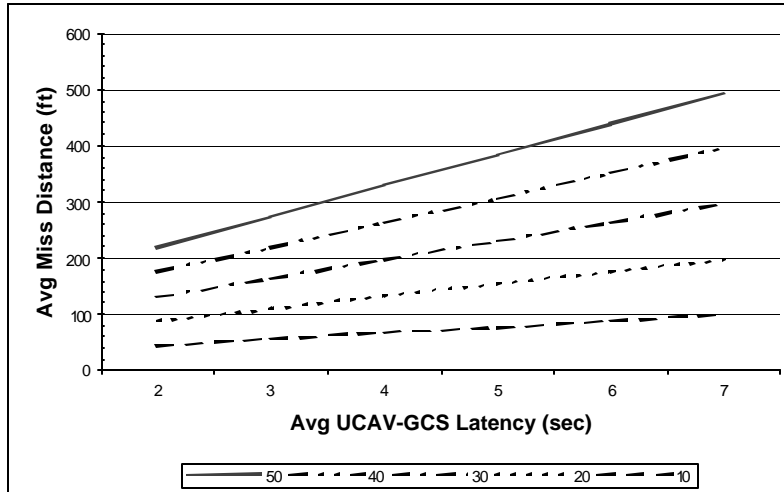

Figure 9. Mobile Target Engagement with Constant Velocity (Latency 2-7 sec)

Scenario Two: Accelerating, Non-maneuvering Target

Signal latency, initial ground target velocity, and ground target acceleration impact potential targeting miss distance.

Figures 10 and 11 depict, on log scale, the average miss distance as a function of signal latency for each initial target ground speed with accelerations of 2 and 4 ft/sec², respectively. To ensure the ground targets velocity does not exceed a reasonable value, the ground targets were given a maximum velocity. As expected, target acceleration directly influences miss distance. Accelerations mean larger miss distance differences as compared to a constant velocity ground target. However, by comparing Figures 10 and 11, as the acceleration increases the maximum velocity becomes a more limiting factor.

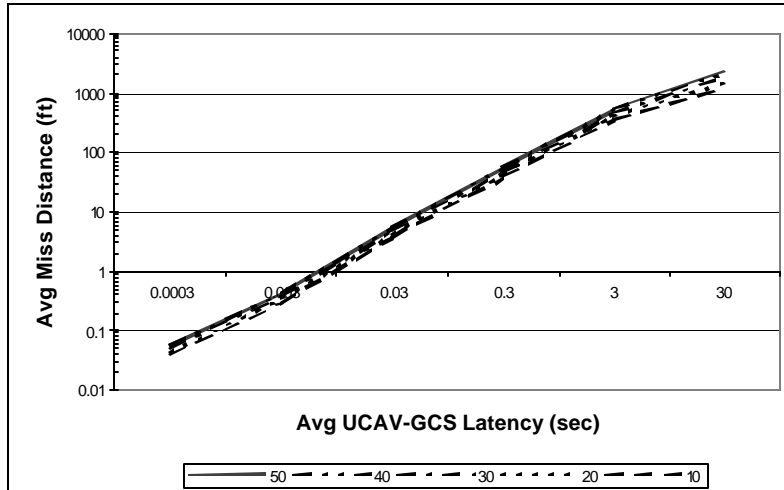

Figure 10. Accelerating Ground Target (2 ft/sec^2), $V_{\text{max}} = 100 \text{ ft/sec}$

As expected, near real time latency translates to very low miss distances (less than a foot), even when the target is accelerating. The implication is clear; with low levels of latency, the impact of acceleration on miss distance is small; however, as latency increases, minor acceleration rates mean even greater targeting inaccuracy.

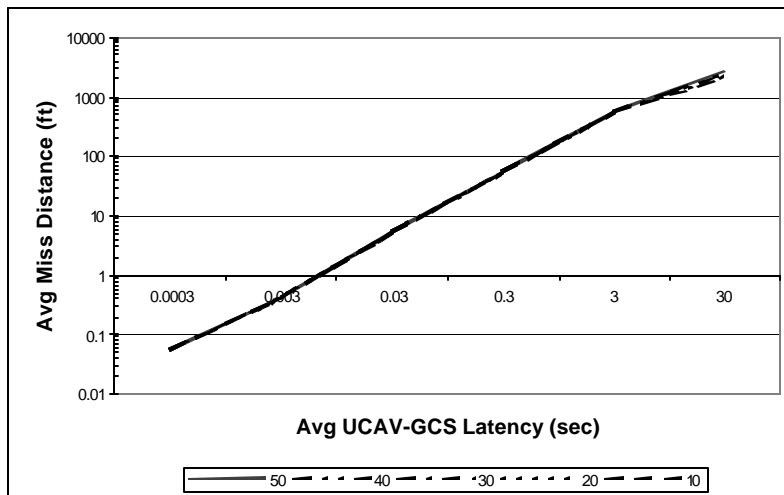

Figure 11. Accelerating Ground Target (4 ft/sec^2), $V_{\text{max}} = 100 \text{ ft/sec}$

Scenario Three: Constant Velocity, Non-Maneuvering Target (w/ Jamming)

Any level of jamming (signal interruption) severely impacts potential targeting miss distance. This relationship caused total transmission disruption at high latency levels.

Figure 12 depicts, on log scale, the average miss distance in a low-level jamming environment as a function of signal latency for each target ground speed modeled.

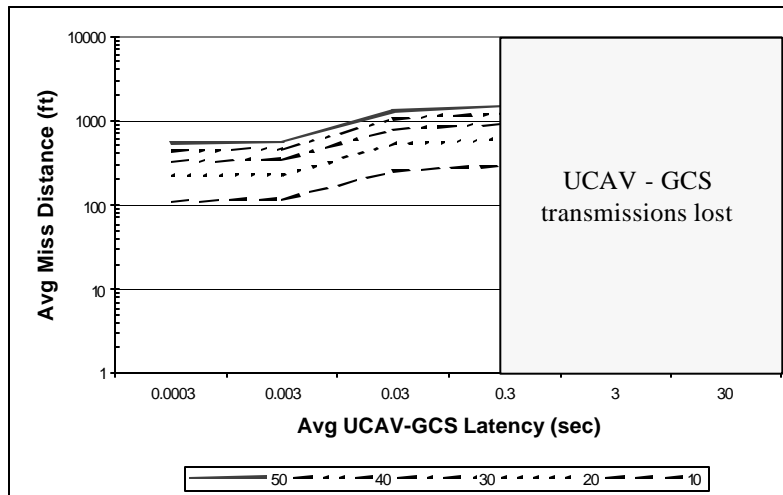

Figure 12. Low Level Jamming Engagement

As expected, target ground speed directly influences miss distance – higher speeds mean larger differences. Any level of latency translates to large miss distances. The implication is clear; any level of jamming or signal interruption during simulation means poor targeting accuracy resulting in inaccurate bombs.

As the level of jamming is increased, the amount of transmissions lost increase. Figures 13 and 14 show the impact of increasing the jamming level.

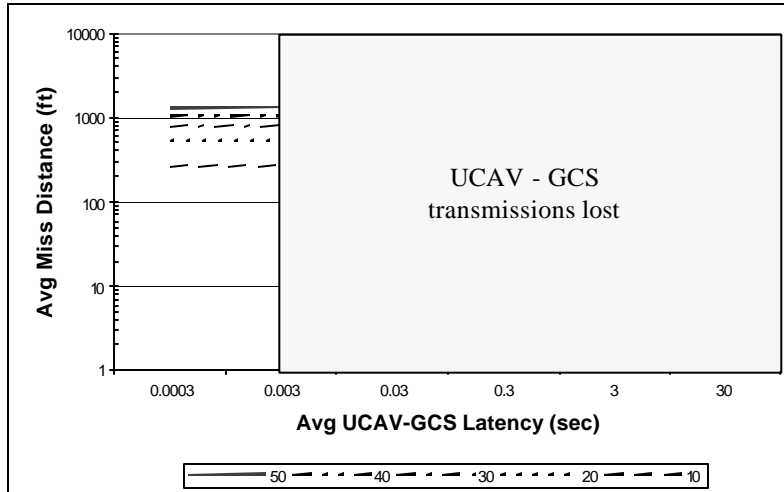

Figure 13. Medium Level Jamming Engagement

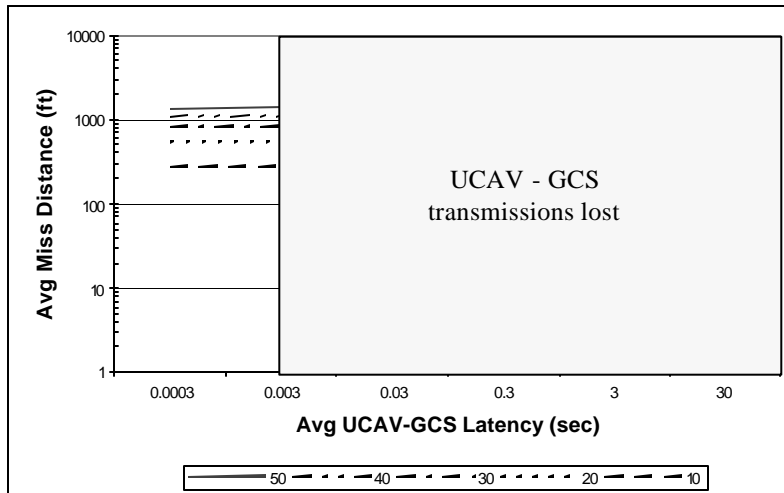

Figure 14. High Level Jamming Engagement

Jamming also influences the miss distance distribution. Since jamming is modeled as a random variable with a specified mean, the miss distance is also a random variable. The variances of observations are extremely large when jamming is present regardless of the level of latency and ground target speed. This is expected as jamming introduces large levels of uncertainty into the model scenario.

Scenario Four: Constant Velocity, Maneuvering Target

Both signal latency and ground target velocity impact potential targeting miss distance; however, maneuvering capability does not impact the average potential targeting miss distance.

Figure 15 depicts, on log scale, the average miss distance of a maneuvering ground target as a function of signal latency for each ground speed modeled. For convenience, Figure 7, which depicts, on log scale, the average miss distance of a non-maneuvering ground target as a function of signal latency for each ground speed modeled, is reproduced as Figure 16 for comparative purposes. As expected, the ability of a target to maneuver does not significantly change miss distance above the influences due to target ground speed and latency. Comparison of Figures 15 and 16 confirms the lack of influence of maneuverability on average miss distance. This result may be an artifact of the random natures of the maneuvers and thus further investigation should be conducted using maneuvering target scenarios.

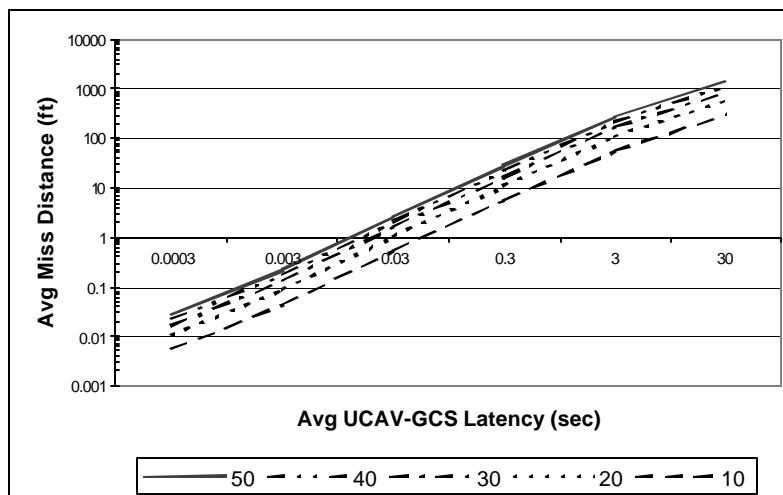

Figure 15. Maneuvering Target with Constant Velocity

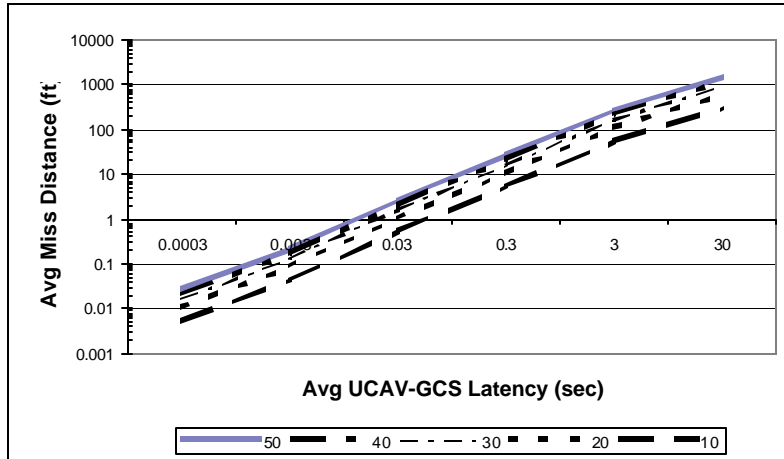

Figure 16. Non-Maneuvering Target with Constant Velocity

Maneuvering, similar to latency and target velocity, does influence the miss distance distribution. Like signal latency, mobile ground target’s direction is modeled as a random variable with a specified mean. As seen in Table 5, the variance of observations expands as latency and ground target speed increase. Since we have introduced an additional level of uncertainty, we expected an increase in variance over a non-maneuvering target. A comparison of Table 3 (non-maneuvering target) and Table 5 (maneuvering target) shows that introducing the maneuvering capability does cause the miss distance variance to increase.

Table 5. Avg Miss Distance Variance (Scenario 4)

Latency (sec)	Velocity (ft/s)				
	50	40	30	20	10
0.0003	0.000030	0.000019	0.000011	0.000005	0.000001
0.003	0.003185	0.002038	0.001146	0.000510	0.000127
0.03	0.043933	0.028117	0.015816	0.007029	0.001757
0.3	0.720447	0.461086	0.259361	0.115272	0.028818
3	7.857572	5.028846	2.828726	1.257212	0.314303
30	1733.986951	1109.751646	624.235304	277.437912	69.359478

Satellite Connectivity Baselines

Each type of satellite connectivity carries some minimum signal latency. Our results suggest an average miss distance on the order of 10 feet for GEO, 1-10 feet for MEO and less than a foot for LEO. These are conservative estimates based on minimum signal latencies rather than actual observed latency values.

Chapter Summary

This chapter explained the impacts that satellite latency and ground target speeds, associated with four different engagement scenarios, have on average miss distance. Regardless of the scenario, target ground speed directly influences miss distance – higher speeds mean larger differences. Also, as expected the greater the satellite latency level, the greater the average miss distances. Jamming effects included severe loss of transmission signal and large average miss distances at even very low latency levels.

V. Conclusions

Satellite signal latency, ground target velocity, and jamming environment impact potential targeting miss distance with varying degrees of severity. Regardless of scenario, the higher the target ground speeds, the larger the average miss distances. Also, as expected, the greater the satellite latency level, the greater the average miss distances. However, at lower latency levels, the average miss distances are quite reasonable (less than a foot) regardless of speed. The introduction of jamming greatly influences the miss distances. When jamming is present with high levels of latency, the transmission between the UCAV and GCS is lost. In addition, with jamming scenarios, miss distances are still quite large even at low levels of satellite latency.

Latency, jamming and target velocity also influences the miss distance distribution. Since signal latency and jamming are modeled as random variables with a specified means, the miss distance is also a random variable. Therefore, as latency increases and/or jamming is present, the variance of observations expands. This is expected as levels of uncertainty are introduced into the model scenario.

Literature Review Findings

This research provides a thorough review of literature relevant to the use of a UCAV as a laser designator for precision munitions against ground mobile targets. We present the type of command and control structure that could be used by a UCAV, specifically addressing the autonomous and man-in-the-loop control methods. We then review current satellite orbitology to better understand possible levels of satellite latency. Associated with satellite latency was bandwidth requirements of UCAV systems.

Finally, we review the dynamic engineering equations used to determine the distance between a mobile target and the UCAVs laser designation when latency or signal degradation exists.

Recommendations for Future Research

Recommendations can be made that could confirm this research. The first recommendation is to identify true satellite latency levels between a UCAV and GCS in multiple environments. Since the jamming scenarios show such a large impact on average miss distances and transmission capability, the second recommendation would be to develop a more realistic jamming environment model based upon actual data. A third recommendation would be to develop a user-friendly interface to the model for input parameters and scenario definition.

Additionally, several recommendations can be made that could expand the capabilities of this research model. The first recommendation would be to incorporate a laser designation algorithm. This algorithm should take into account probability of designation, angle of incidence, heading angles, and other factors. A second recommendation would be to incorporate a GCS operation algorithm to take into account operator error. A third recommendation would be some weapon effectiveness algorithm. This algorithm should include attributes of type of weapon, weather effects, delivery altitudes, seeker gimble limits, and weapon energy envelopes. This would augment miss distance data with lethality assessments to provide probability of target kill information.

Appendix A. ARENA MODEL

This Appendix explains the basic layout of our ARENA model to include variable definitions and algorithm design. All the process variables can be accessed from the Basic Process Template by selecting [Variable]. Table 6 depicts the variables (and their definition) that are set-up prior to each scenario. The variables in Table 6 do not change their value during each replication.

Table 6. Initial Setting Variables

MessageFreq	Frequency of Messages Sent From UCAV and GCS
UGLB	UCAV to GCS Latency Lower Bound
UGUB	UCAV to GCS Latency Upper Bound
Atar	Target Acceleration
GULB	GCS to UCAV Latency Lower Bound
GUUB	GCS to UCAV Latency Upper Bound
TOF	Time of Flight (Scenario Length)
TTD	Time to Designate (Measured from end of Scenario)
VtarMax	Maximum Velocity of Target
VUCAV	Velocity of UCAV
AUCAV	Acceleration of UCAV
FreqMove	Frequency of Target Changing Direction
CdirLB	Target Change of Direction Lower Bound
CDirUB	Target Change of Direction Upper Bound
UCAVHeading	UCAV Heading
JAM LEVEL	Jamming Environment Level (1, 2, or 3)

Table 7 depicts the Boolean variables incorporated within the ARENA model. DESIGNATOR, TgtChgDir, and JAM ENVIRO are set prior to each scenario. JAMMED, REC, and SET are changed during a simulation.

Table 7. Boolean Variables (1 = Yes)

DESIGNATOR	Is Designator Turned On?
TgtChgDir	Is Target Manuevering?
JAMMED	Is Transmission Currently Jammed?
REC	Has UCAV Received a Transmission From GCS?
SET	Has the Percentage Chance of Jamming Been Set?
JAM ENVIRO	Does the Potential For Jamming Exist?

Table 8 depicts the remainder of the variables used within the ARENA model.

Table 8. Global Variables

VTarUpdate	Updated Target Velocity (place holder variable)
VTar	Target Velocity
TX	X-Direction Location of Target
TY	Y-Direction Location of Target
TOJ	Time Jamming Occurred
LOJ	Length of Jam
DIR	Heading of Target
GX	X-Direction of Target Seen By GCS
GY	Y-Direction of Target Seen By GCS
TSL_Update	Time Since Last Update
TL_Update	Time of Last Update
LXLoc	X-Location of Laser
LYLoc	Y-Location of Laser
DELAY1	Length of Delay of Signal From UCAV to GCS
DELAY2	Length of Delay of Signal From GCS to UCAV
VStor	Stored Perceived Velocity of Target as Last Seen By GCS
AStor	Stored Perceived Acceleration of Target as Last Seen By GCS
Sdir	Stored Perceived Direction of Target as Last Seen By GCS
LastPicture	Time Last Transmission Received from UCAV
TIMEi	Time Current Message Received by GCS
TIMEj	Time Current Message Received by UCAV
LEVEL	Percentage Chance of Transmission Jammed

Figures 17 – 21 depict the algorithms found in ARENA 5.0 file

UCAV_Baseline18Feb. The file is a baseline model not including the jamming environment capability. Each figure depicts their respective flow of information.

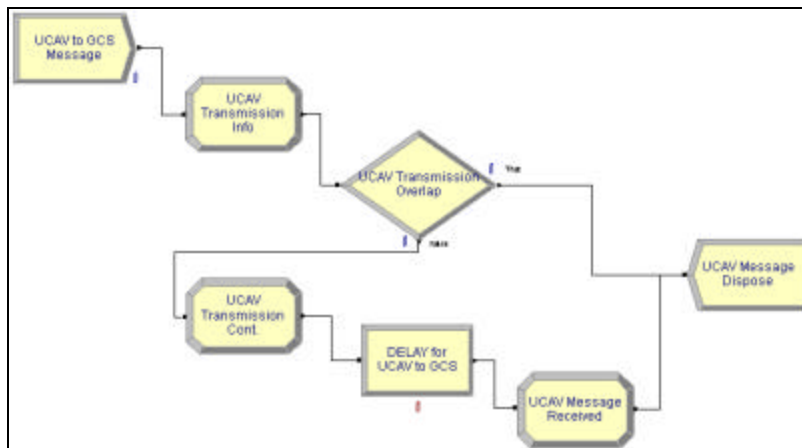

Figure 17. UCAV to GCS Transmission Algorithm w/o Jamming

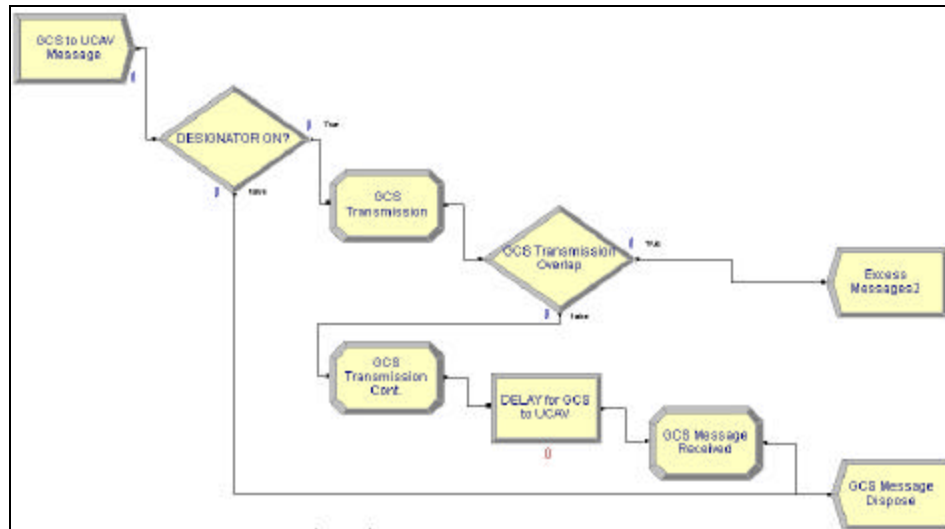

Figure 18. GCS to UCAV Transmission Algorithm w/o Jamming

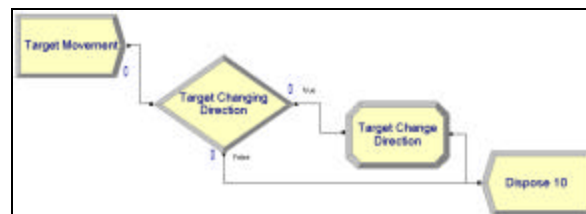

Figure 19. Target Maneuvering Algorithm

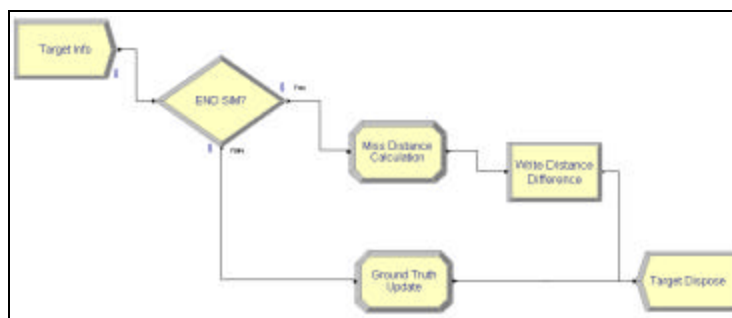

Figure 20. Target Update/End Simulation Algorithm

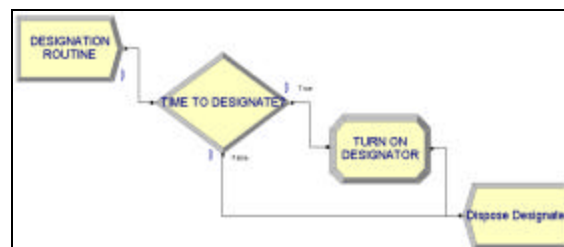

Figure 21. Designation Algorithm

Figures 22 – 24 depict the changes in algorithms from the baseline model. The jamming model can be found in ARENA 5.0 file UCAV_Jam18Feb. Figure 22 (23) shows the change to the UCAV to GCS (GCS to UCAV) Transmission Algorithm when jamming potential is added to model. Figure 24 depicts the actual jamming algorithm.

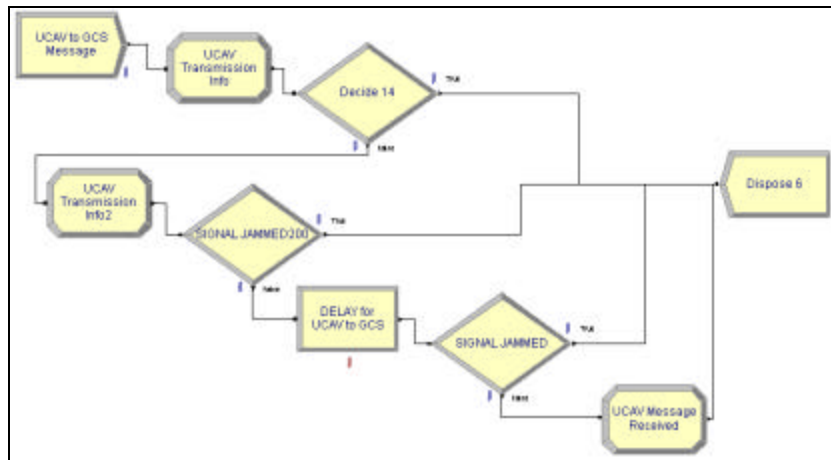

Figure 22. UCAV to GCS Transmission Algorithm w/ Jamming

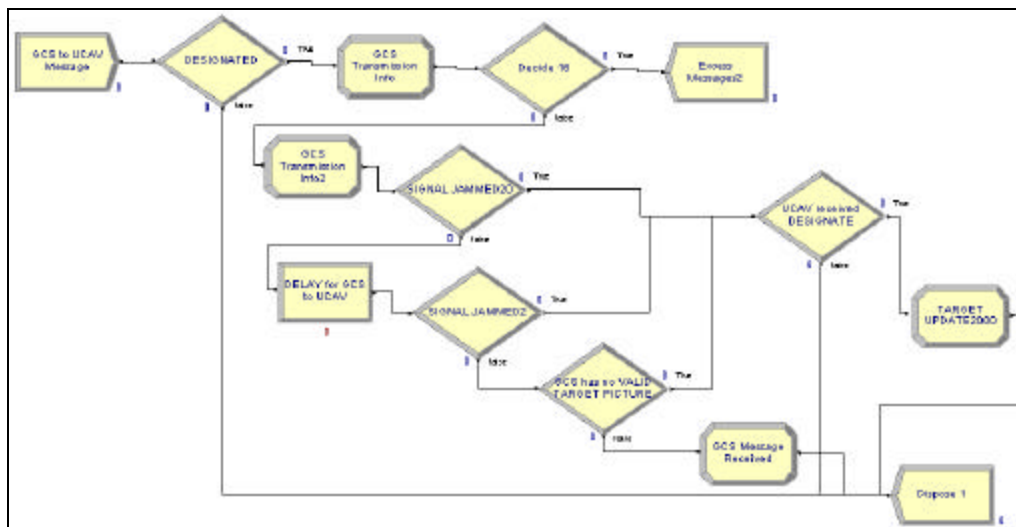

Figure 23. GCS to UCAV Transmission Algorithm w/ Jamming

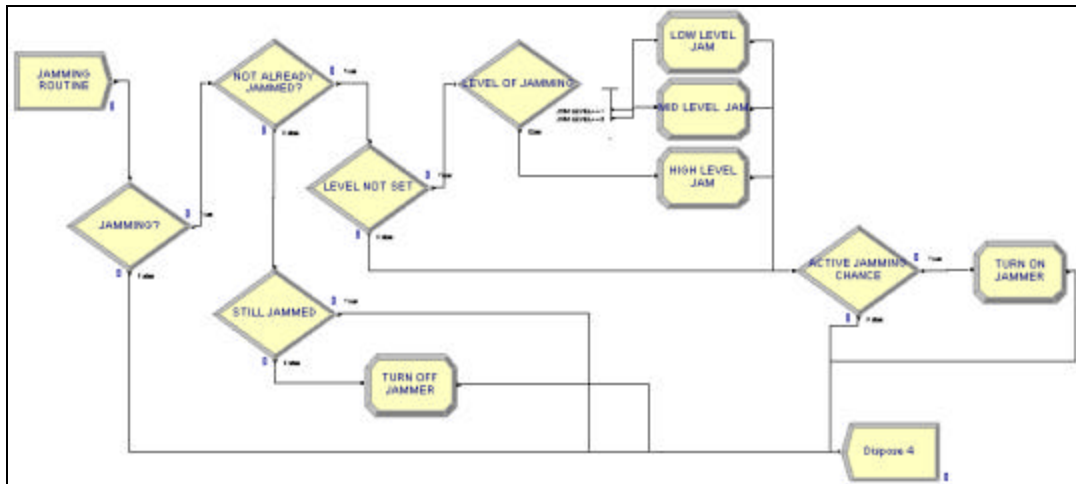

Figure 24. Jamming Algorithm

Bibliography

1. Defense Advanced Research Projects Agency. "Unmanned Combat Air Vehicle Advanced Technology Demonstration (UCAV ATD) Phase I Selection Process Document ('Solicitation')." Taken from website: <http://www.fas.org/man/dod-101/sys/ac/docs/ucav-sol.html>, 26 July 2001.
2. DefenseLink News. "DARPA and Air Force Select UCAV Contractors." Taken from website: http://www.fas.org/man/dod-101/sys/ac/docs/b04161998_bt178-98.html, 28 July 2001.
3. DefenseLink News. "DARPA and Air Force Select Boeing To Build UCAV Demonstrator System." Taken from website: http://www.fas.org/man/dod-101/sys/ac/docs/b03241999_bt123-99.htm, 28 July 2001.
4. Lawson, Cliff. "UCAVs may find niche in 21st Century." The Rocketeer, 25 June 1998.
5. Marsh, Nicholas. "GR57. Issues involved in developing pilotless combat aircraft." Taken from website: <http://www.ukdf.org.uk/gr57.html>, 27 July 2001.
6. Kopp, Carlo. "The UCAV Ascendary: What are the Problem Issues?" Taken from website: <http://www.csse.monash.edu.au/~carlo/archive/MILITARY/ADFA/ucav-2001.pdf>, 27 July 2001.
7. Nolan, Robert C. II. The Pilotless Air Force? A Look at Replacing Human Operators with Advanced Technology. Maxwell Air Force Base AL: Air Command and Staff College, Air University: March 1997.
8. Canan, James W. "Seeing more, and risking less, with UAVs." Aerospace America, October 1999, Volume 37, Number 10.
9. Clark, Richard. Uninhabited Combat Aerial Vehicles: Airpower by the People, For the People, But Not with the People. Maxwell Air Force Base AL: Air University Press CADRE Paper: August 2000.
10. Naval Studies Board. *Network-Centric Naval Forces: A Transition Strategy for Enhancing Operational Capabilities*. Washington DC: National Academy Press: 2000.
11. Nichols, Mark. Uninhabited Combat Air Vehicles and Commercial Satellites: "The Missing Link." Maxwell Air Force Base AL: Air War College, Air University: April 1998.

Vita

Captain Shane A. Dougherty entered the United States Air Force Academy in June of 1990. He graduated in June of 1994 with a Bachelor of Science degree in Aeronautical Engineering. He was a distinguished graduate and assigned to the 46th Test Wing (Air Force SEEK Eagle Office) at Eglin AFB, Florida. While stationed there, he worked as an aircraft and stores structural strength engineer performing flight clearances and certifications.

In April 1997, he transferred to the Single-Face-to-Customer Office at Eglin AFB, Florida to work as a test planning officer. In September 1998, he was transferred to the National Air Intelligence Center, Wright-Patterson AFB, Ohio to be a system threat analyst. In June 2000, he attended Squadron Officer School, Maxwell AFB, Alabama. He was a distinguished graduate and in August 2000, he entered the Graduate School of Engineering and Management, Air Force Institute of Technology, Wright Patterson Air Force Base, Ohio. Upon graduation, he will be assigned to the 422nd Test and Evaluation Squadron, Nellis AFB, Nevada.

REPORT DOCUMENTATION PAGE

*Form Approved
OMB No. 074-0188*

The public reporting burden for this collection of information is estimated to average 1 hour per response, including the time for reviewing instructions, searching existing data sources, gathering and maintaining the data needed, and completing and reviewing the collection of information. Send comments regarding this burden estimate or any other aspect of the collection of information, including suggestions for reducing this burden to Department of Defense, Washington Headquarters Services, Directorate for Information Operations and Reports (0704-0188), 1215 Jefferson Davis Highway, Suite 1204, Arlington, VA 22202-4302. Respondents should be aware that notwithstanding any other provision of law, no person shall be subject to a penalty for failing to comply with a collection of information if it does not display a currently valid OMB control number.

PLEASE DO NOT RETURN YOUR FORM TO THE ABOVE ADDRESS.

1. REPORT DATE (DD-MM-YYYY) 26-03-2002		2. REPORT TYPE Master's Thesis		3. DATES COVERED (From - To) May 2001 - Mar 2002	
4. TITLE AND SUBTITLE AN EXAMINATION OF LATENCY AND DEGRADATION ISSUES IN UNMANNED COMBAT AERIAL VEHICLE ENVIRONMENTS				5a. CONTRACT NUMBER	
				5b. GRANT NUMBER	
				5c. PROGRAM ELEMENT NUMBER	
6. AUTHOR(S) Dougherty, Shane A., Captain, USAF				5d. PROJECT NUMBER	
				5e. TASK NUMBER	
				5f. WORK UNIT NUMBER	
7. PERFORMING ORGANIZATION NAMES(S) AND ADDRESS(S) Air Force Institute of Technology Graduate School of Engineering and Management (AFIT/ENS) 2950 P Street, Building 640, WPAFB OH 45433-7765				8. PERFORMING ORGANIZATION REPORT NUMBER AFIT/GOR/ENS/02-05	
9. SPONSORING/MONITORING AGENCY NAME(S) AND ADDRESS(ES) Unmanned Aerial Vehicle BatteLab 1003 Nomad Way, Suite 107 Eglin AFB, FL. 32542-6867				10. SPONSOR/MONITOR'S ACRONYM(S)	
				11. SPONSOR/MONITOR'S REPORT NUMBER(S)	
12. DISTRIBUTION/AVAILABILITY STATEMENT APPROVED FOR PUBLIC RELEASE; DISTRIBUTION UNLIMITED.					
13. SUPPLEMENTARY NOTES					
14. ABSTRACT There are two basic ways to control an Unmanned Combat Aerial Vehicle (UCAV) as it searches for targets, allow the UCAV to act autonomously or employ man-in-the-loop control. There are also two target sets of interest: fixed or mobile targets. This research focuses on UCAV-based targeting of mobile targets using man-in-the-loop control. In particular, the interest is in how levels of satellite signal latency or signal degradation effect the ability to accurately track, target, and attack mobile targets. This research establishes a weapon effectiveness model assessing targeting inaccuracies as a function of signal latency and/or signal degradation. The research involved three phases. The first phase in the research was to identify the levels of latency associated with satellite communication. A literature review, supplemented by interviews with UAV operators, provided insight into the expected range of latency values. The second phase of the research identified those factors whose value, in the presence of satellite latency, could influence targeting errors during UCAV employment. The final phase involved developing and testing a weapon effectiveness model explicitly modeling satellite latency in UCAV targeting against mobile targets. This phase included an effectiveness analysis study.					
15. SUBJECT TERMS Unmanned Aerial Vehicle, UAV, Unmanned Combat Aerial Vehicle, UCAV, simulation, ARENA					
16. SECURITY CLASSIFICATION OF:		17. LIMITATION OF ABSTRACT UU	18. NUMBER OF PAGES 55	19a. NAME OF RESPONSIBLE PERSON Raymond R. Hill, LtCol, USAF	
a. REPORT U	b. ABSTRACT U			c. THIS PAGE U	19b. TELEPHONE NUMBER (Include area code) (937) 255-6565, ext 4323 (Raymond.Hill@afit.edu)