



NAVAL FACILITIES ENGINEERING SERVICE CENTER  
Port Hueneme, California 93043-4370

---

---

## USER DATA PACKAGE UDP-2008-ENV

### AIR-PROPANE PROPORTIONING DEVICE FOR NAVAL FIREFIGHTER TRAINING FACILITIES (FFTFS)

by

Robert Levine  
Tom Sheng Lin  
Richard Lee

March 2001

20020204 151

---

Approved for public release; distribution is unlimited.

Reproduced From  
Best Available Copy

 Printed on recycled paper

REPORT DOCUMENTATION PAGE			Form Approved OMB No. 0704-0188	
Public reporting burden for this collection of information is estimated to average 1 hour per response, including the time for reviewing instructions, searching existing data sources, gathering and maintaining the data needed, and completing and reviewing the collection of information. Send comments regarding this burden estimate or any other aspect of this collection of information, including suggestions for reducing this burden to: Washington Headquarters Services, Directorate for Information Operations and Reports, 1215 Jefferson Davis Highway, Suite 1204, Arlington, VA 22202-4302, and to the Office of Management and Budget, Paperwork Reduction Project (0704-0188), Washington, DC 20503.				
1. AGENCY USE ONLY (Leave blank)	2. REPORT DATE November 2000		3. REPORT TYPE AND DATES COVERED Not Final; Sept 1998 – Sept 2000	
4. TITLE AND SUBTITLE <b>AIR-PROPANE PROPORTIONING DEVICE FOR NAVAL FIREFIGHTER FACILITIES (FFTF)</b>			5. FUNDING NUMBERS	
6. AUTHOR(S) Robert Levine, Tom Sheng Lin, and Richard Lee				
7. PERFORMING ORGANIZATION NAME(S) AND ADDRESS(ES) Commanding Officer Naval Facilities Engineering Service Center 1100 23 <sup>RD</sup> Ave Port Hueneme, CA 93043-4370			8. PERFORMING ORGANIZATION REPORT NUMBER UDP-2008-ENV	
9. SPONSORING/MONITORING AGENCY NAME(S) AND ADDRESS(ES) Commander Naval Facilities Engineering Command Washington Navy Yard 1322 Patterson Ave SE STE 1000 Washington DC 20374-5065			10. SPONSORING/MONITORING AGENCY	
11. SUPPLEMENTARY NOTES				
12a. DISTRIBUTION/AVAILABILITY STATEMENT Approved for public release; distribution is unlimited.			12b. DISTRIBUTION CODE	
13. ABSTRACT (Maximum 200 words)  The Naval Facilities Engineering Service Center (NFESC) was tasked by the Naval Facilities Engineering Command (NAVFAC) to investigate the feasibility of reducing air pollution emissions from the Navy Fire Fighter Training Facilities (FFTF). As a part of this task, the NFESC assessed the feasibility of using a 50-50 air-propane fuel as an alternative fuel to the current use of 100 percent propane fuel and adopted an air-propane proportioning device which can mix and supply air and propane mixture automatically. The air-propane proportioning device is a commercial available, off-of-the-shelf item which is commonly installed as "standby" device to substitute natural gas with an air-propane mixture on short notice. The results of this study indicated that air pollution emissions are reduced approximately 40 percent and fuel costs are reduced by 50 percent because only half of the fuel will be used. Operational safety is assured because the specified amount of air in the propane is less than a quarter of air required to reach the upper combustible limit and the control box for the controlling the air-propane proportioning device is an explosion proof device.				
14. SUBJECT TERMS Fire Fighter Training Facilities, air-propane mixture, proportioning device			15. NUMBER OF PAGES 85	
			16. PRICE CODE	
17. SECURITY CLASSIFICATION OF REPORT U	18. SECURITY CLASSIFICATION OF THIS PAGE U	19. SECURITY CLASSIFICATION OF ABSTRACT U	20. LIMITATION OF ABSTRACT U	

## PREFACE

The Naval Facilities Engineering Service Center (NFESC), Port Hueneme, California, was tasked by the Naval Facilities Engineering Command (NAVFAC) to investigate the feasibility of reducing air emissions from existing propane-fueled Naval Fire Fighter Training Facilities (FFTF). This can be accomplished by using a proportioning device to pre-mix a controlled amount of air to the propane. In addition to the environmental benefit, this air-propane pre-mix reduces the fuel consumption substantially.

The air-propane-proportioning device that was tested is commercially available. Similar devices can be easily procured from many manufacturers.

A series of field demonstration tests were carried out using an actual Navy FFTF "bilge" fireplace at the Maryland Fire and Rescue Institute (MFRI), University of Maryland from 1998 through 2000. The appearance of the flame (e.g., color, shape, etc.) was observed and documented. Samples of air pollutants were collected and analyzed. The results of laboratory and field tests, laboratory analyses, and engineering assessment are documented in this User Data Package.

## EXECUTIVE SUMMARY

Air-propane proportioning devices have been widely used in industries to mix air and propane as an alternative fuel. The proportioning device is used when the supply of natural gas may have to be temporarily interrupted and a mixture of air-propane used as an alternative fuel. An air-propane-proportioning device is commonly installed as "standby" device to substitute natural gas with an air-propane mixture on short notice.

The U.S. Navy adopted the air-propane-proportioning device for reasons other than industrial. The U.S. Navy wants to know whether the device can be used to reduce air pollutants emitted from FFTF, which currently use 100 percent propane as fuel. To achieve this objective, the Naval Facilities Engineering Service Center (NFESC) undertook the task to assess the feasibility of using an air-propane mixture as an alternative to the current use of 100 percent propane fuel. Several reports documenting the assessment of feasibility and benefits were presented (Lee, 1993 and Roby, et al., 1996a and 1996b).

The advantages of the 50-50 mixture of air and propane by volume over the 100 percent propane fuel are summarized as follows:

- Air pollution emissions are reduced approximately 40 percent
- Fuel cost are reduced by 50 percent
- Safety is assured because the specified amount of air in the propane is less than a quarter of the air required to reach the upper combustible limit.

Based on the results of this investigation, the air-propane-proportioning device is recommended to be installed at all FFTFs in order to reduce air pollution and fuel cost.

## TABLE OF CONTENTS

	Page
1.0 INTRODUCTION .....	1-1
1.1 Background .....	1-1
1.2 Brief Description of FFTF .....	1-1
1.3 Fuel for Current FFTFs .....	1-3
1.4 Objectives .....	1-7
2.0 SYSTEM DESCRIPTION .....	2-1
2.1 Introduction to the Equipment .....	2-3
2.2 Description of the Equipment .....	2-3
2.3 The Vaporizer .....	2-9
2.4 The Mixer .....	2-9
2.5 The Control Box .....	2-9
2.6 The LPG Liquid Pump .....	2-10
3.0 INSTALLATION .....	3-1
4.0 EXPERIMENTAL RESULTS .....	4-1
4.1 Flame Appearance .....	4-1
4.1.1 Laboratory Flames .....	4-1
4.1.2 Full Scale Flames .....	4-6
4.1.2.1 Apparatus .....	4-6
4.1.2.2 Flame Observation Tests .....	4-6
4.1.2.3 Conclusion of Flame Observation Tests .....	4-7
4.2 Reflash/Re-ignition .....	4-13
5.0 POLLUTANT MEASUREMENTS .....	5-1
5.1 Overview on Generation of Pollutants .....	5-1

## TABLE OF CONTENTS

	Page
5.1.1 Introduction.....	5-1
5.2 Apparatus .....	5-2
5.3 Exhaust Gas Sampling .....	5-2
5.4 Data .....	5-5
5.4.1 Calculations.....	5-6
5.5 Conclusions on Air Pollutant Emissions.....	5-6
6.0 ECONOMIC FEASIBILITY – ESTIMATED COST/BENEFIT ANALYSIS.....	6-1
6.1 Total Annual Propane Consumption.....	6-1
6.2 Annual Fuel Costs.....	6-1
6.3 Modification Costs.....	6-2
6.4 Payback Assessment .....	6-3
7.0 OPERATION AND MAINTENANCE.....	7-1
7.1 Adjustment procedures for System Operating and Safety Controls .....	7-1
7.1.1 Motive Pressure (set pressure of the venturi regulator).....	7-1
7.1.2 System Delivery Pressure .....	7-2
7.1.2.1 Pressure Control Switch .....	7-2
7.1.2.2 High Tank Pressure Switch .....	7-2
7.1.2.3 Low Vapor Pressure Switch .....	7-2
7.1.2.4 Further Maintenance and Troubleshooting Information .....	7-2
7.2 Operation and Maintenance of the Liquid Propane Pump.....	7-2
7.2.1 Initial Startup .....	7-2
7.2.1.1 Operation Check.....	7-2
7.2.2.2 Verify that the Pump System has Been Installed Correctly.....	7-3
7.2.1.3 Pump Setting and Adjustment Procedures .....	7-3
7.2.1.3.1 Adjusting Output Setpoint .....	7-3
7.2.1.3.2 Internal Pump Relief Valve Adjustment.....	7-4

## TABLE OF CONTENTS

	Page
7.2.2 Operation.....	
7.2.3 Maintenance Procedures .....	
8.0 PROPANE MATERIAL SAFETY DATA SHEET (MSDS) .....	8-1
9.0 CONCLUSIONS AND RECOMMENDATIONS .....	9-1
9.1 Conclusions.....	9-1
9.2 Recommendations.....	9-1
10.0 ACKNOWLEDGEMENTS.....	10-1
11.0 REFERENCES .....	11-1

## APPENDICES

Appendix A – Chemical Analysis Results.....	A-1
Appendix B – Safety and Automatic Operational Features of the Vaporizer/Mixer and “STABILAIR” LPG Pump Package .....	B-1
Appendix C – Sam Dick Industries Operation and Maintenance Manuals .....	C-1
Appendix D – Material Safety Data Sheet for Propane.....	D-1

## LIST OF FIGURES

Figure 1-1	19F1A advanced fire fighter trainer.....	1-4
Figure 1-2	Upper floor fireplaces in 19F1A trainer.....	1-5
Figure 1-3	Lower floor fireplaces in 19f1 trainer.....	1-6
Figure 2-1	“Standby” air-propane mixing system .....	2-2
Figure 2-2	Propane tank, air mixer, and burner at MFRI .....	2-5
Figure 2-3	1,000-gallon propane tank .....	2-5
Figure 2-4	Major Components Drawing.....	2-6
Figure 2-5	Detail of XPV vaporizer/mixer system.....	2-7
Figure 2-6	Detail of control box .....	2-11
Figure 2-7	Liquid propane pump.....	2-12
Figure 3-1	Installation of liquid propane pump.....	3-2
Figure 4-1	Propane feed system and rotameters.....	4-2
Figure 4-2	Bilge burner segment attached to mixing tube .....	4-3
Figure 4-3	Flame along long side of burner, propane only .....	4-3
Figure 4-4	Flame along long side of burner, air-propane mix.....	4-4

Figure 4-5	Flame along short side of burner, propane only .....	4-4
Figure 4-6	Flame along short side of burner, air-propane mix .....	4-5
Figure 4-7	Eclipse Company nozzle mixing pilot .....	4-5
Figure 4-8	“Standby” air-propane mixing system .....	4-7
Figure 4-9	Bilge burner from 19F5 trainer .....	4-8
Figure 4-10	Propane fire at 80 SCFM, 1/500 second exposure.....	4-8
Figure 4-11	Propane fire at 80 SCFM, 1/250 second exposure.....	4-9
Figure 4-12	50-50 air-propane fire at 80 SCFM, 1/250 second exposure .....	4-9
Figure 4-13	50-50 air-propane fire at 80 SCFM, 1/250 second exposure .....	4-10
Figure 4-14	Propane fire at 40 SCFM, 1/250 second exposure.....	4-10
Figure 4-15	Propane fire at 40 SCFM, 1/250 second exposure.....	4-11
Figure 4-16	50-50 air-propane fire at 40 SCFM, 1/250 second exposure .....	4-11
Figure 4-17	50-50 air-propane fire at 40 SCFM, 1/250 second exposure .....	4-12
Figure 4-18	50-50 air-propane fire at 40 SCFM, 1/30 second exposure .....	4-12
Figure 4-19	Grating assembled over burner .....	4-14
Figure 5-1	Burner assembly without grating .....	5-3
Figure 5-2	Flames issuing through grating .....	5-3
Figure 5-3	Flames issuing through grating, showing water-cooled probe .....	5-4
Figure 5-4	Collector pan with probes inserted inside .....	5-4

#### LIST OF TABLES

Table 1-1	A Summary of Navy Fire Fighting Trainers.....	1-2
Table 1-2	Description of Navy Fire Fighter Trainers.....	1-2
Table 2-1	List of Manufacturers of Air-Propane Proportioning Devices .....	2-3
Table 2-2	XPV Major Component Identification.....	2-8
Table 2-3	Liquid Propane Pump Components .....	2-13
Table 5-1	Emission of Air Pollutants With 100 Percent Propane Fuel and 50-50 Air-Propane Mixture.....	5-1
Table 5-2	Summary Results of Air Pollutants With 100 percent Propane (Test #6) .....	5-5
Table 6-1	Annual Propane Consumption of FFTFs .....	6-2
Table 6-2		

## CHAPTER 1.0

### 1.0 INTRODUCTION

#### 1.1 BACKGROUND

Shipboard fires represent a constant threat to the safety of personnel, the operational capability of naval forces, and may result in compromising the mission. The U.S. Navy requires all officers and enlisted personnel to complete the required fire fighting training prior to reporting to their first duty station. The training includes skills in fire fighting, use of equipment, and skills of communication in reporting fire casualty and damage information as defined in OPNAVINST 3541.1 (series). All officers and enlisted personnel must be retrained in fire fighting at least once every 4 years thereafter. All personnel are trained to fight one or more classes of fires.

In an effort to upgrade this training capability, the Chief Naval Education and Training (CNET), through the Training Systems Division of Naval Air Warfare Center (NAWC), conducted a program to provide the environmental friendly fire fighter training facilities (FFTF). The FFTFs were built onshore to allow the trainees to learn fire fighting skills under a controlled environment, free of danger of injury or exposure to hazards.

There are three classes of fires. Each requires a distinctive fire fighting approach and use of extinguishing agents. A brief description of these classes of fire is:

- Class A Fire: The fire is on paper, clothes, trash and other solid materials. The fire may be located in a storage compartment, locker room, trash can, ventilation duct, clothes dryer, on hull insulation, etc.
- Class B Fire: The fire is on oil, grease, or other liquid or semi-liquid material which may be encountered in the bilge, oil spray from a leak, a pit, a crashed aircraft or other spill on the deck, deep fat fryer, oil contaminated vent hood, etc.
- Class C Fire: The fire is on a charged electric appliance or utility. The fire may be on an electric motor, generator, on electronic equipment and components, on an electric panel, or electric wire bundle.

#### 1.2 BRIEF DESCRIPTION OF FFTF

The U.S. Navy currently owns and operates 18 FFTFs at ten Naval activities within the continental United States and Hawaii. A total of 22 FFTFs have been built and operated since 1989, however 4 of them were closed under the Base Realignment And Closure (BRAC) act. A summary of Navy FFTFs including locations, fire fighting training institutions, devices, operational dates, and current status (active or inactive) is shown in Table 1-1.

Table 1-1. A Summary of Navy FFTFs

(a) Active Status

Type of Trainer	Training Institution	Devices	Operation Date	
Submarine Fire Fighting Trainer	NSS, New London CT	21C12	Oct	1989
	STF, San Diego CA	21C12	Apr	1991
	STF, Norfolk VA	21C12A	Jul	1992
	NSTCP, Pearl Harbor HI	21C12A	Mar	1993
	TTF, Bangor ME	21C12A	Nov	1993
	TTF, Kings Bay GA	21C12A	May	1996
Advanced Fire Fighting Trainer	FTC, Mayport FL	19F1A/3	Jun	1990
	FTC, San Diego CA	19F1B	Nov	1994
	FTC, Norfolk VA	19F1B	Mar	1995
Basic Fire Fighting Trainer	NETC, Newport, RI	19F3A	Sep	1992
	FTC, San Diego CA	19F3B	Nov	1994
	FTC, Norfolk VA	19F3B	Mar	1995
	NS, Ingleside, TX	19F3C	Jan	1997
	NTC, Great Lakes IL	19F3C	May	1997
Open Burn Fighting Trainer	FTC, San Diego CA	19F4A	Mar	1996
	FTC, Norfolk VA	19F4A	Apr	1996
	FTC, Mayport, FL	19F4A	Apr	1996
Recruit Fire Fighting Trainer	NTC, Great Lakes IL	19F5	Nov	1990

(b) Inactive Status due to BRAC

NTTC, San Francisco CA	19F4	Mar	1991
NTTC, San Francisco CA	19F1A/3	Oct	1992
RTC, Orlando FL	19F5A	Dec	1992
RTC, San Diego CA	19F5A	Jan	1993

A typical FFTF may consist of one or more burners or fireplaces to simulate various types or classes of fires. Figure 1-1 is an FFTF, designated as "19F1A, Advanced Fire Fighting Trainer." Figures 1-2 and 1-3 show fireplaces on the upper and the lower floors, respectively (LANTDIV, 1987).

The Navy has developed several types of FFTFs for specific training functions and purposes. The general description of these FFTFs devices are listed in Table 1-2.

Table 1-2. Description of Navy FFTFs Devices

Device	General Description
19F1(series)	Advanced Fire Fighting Trainer
19F3(series)	Basic Fire Fighting Trainer
19F4(series)	Open Burn Fighting Trainer
19F5(series)	Recruit Fire Fighting Trainer
21C12(series)	Submarine Fire Fighting Trainer

### 1.3 FUEL FOR CURRENT FFTFS

The current FFTF devices use 100 percent propane as fuel in the fireplaces. Propane is not a significant fuel on most naval vessels, but it has been used in the FFTFs to simulate fires of jet fuel, diesel fuel, waste oils, grease, electrical motors and appliances. The advantages of using propane fuel for fire fighting training:

- The fuel bed does not need to be restored after each training session.
- The residual burn or flashback of a fire is minimal.
- The fire can be safely controlled during an emergency by shutting off a control valve. In normal operation, a computer controls the valve to simulate the actions of a real fire as it responds to suppression.
- Propane leaks can be detected easily at floor level.

The U.S. Navy, like many private industries, is under increased regulatory and monetary pressures to reduce the quantities of air pollutants generated each year, as well as budgetary pressure to reduce costs that can be accomplished without deteriorating functions.

Reducing Air Pollutants. Adding a controlled amount of air to propane reduces emissions by approximately 40 percent. Reduction of carbon monoxide (CO) emissions was also observed during the laboratory tests and in the field demonstration tests.

Fuel Savings. In addition to the reduction of the air pollutants, the use of air-propane pre-mix also significantly reduces the amount of propane used, thus achieving energy cost savings.

For the training purpose the propane fire must look like the fire of hydrocarbon waste, or other fuels. For this reason, the propane is not mixed with stoichiometric air before combustion, as it would be mixed in a commercial furnace, which has efficient, blue, hot, short flames. Instead it issues as many small jets from burners in the "fireplaces" in the FFTFs. The propane gas burns as long tongues in turbulent diffusion flames as it mixes with air. The flame creates soot and small amounts of other chemical species that cause yellow flame luminosity, like the flames of solid or liquid fuels.

Most of the chemical species are burned up in the flames, but a small fraction of propane and its derivative escapes unburned, and constitutes air pollutants. This existing pollution is far less than the pollution created by burning pools of hydrocarbon wastes or liquid fuels.

NFESC instituted this program to look into the possibility that the emission of pollutants could be further reduced by mixing a controlled amount of air with the propane before combustion. Based on the results of laboratory tests (Roby, Scheffey, and Hamer, 1996a), it is suggested that the use of 50-50 air-propane mixture as an alternative to 100 percent propane fuel is feasible.

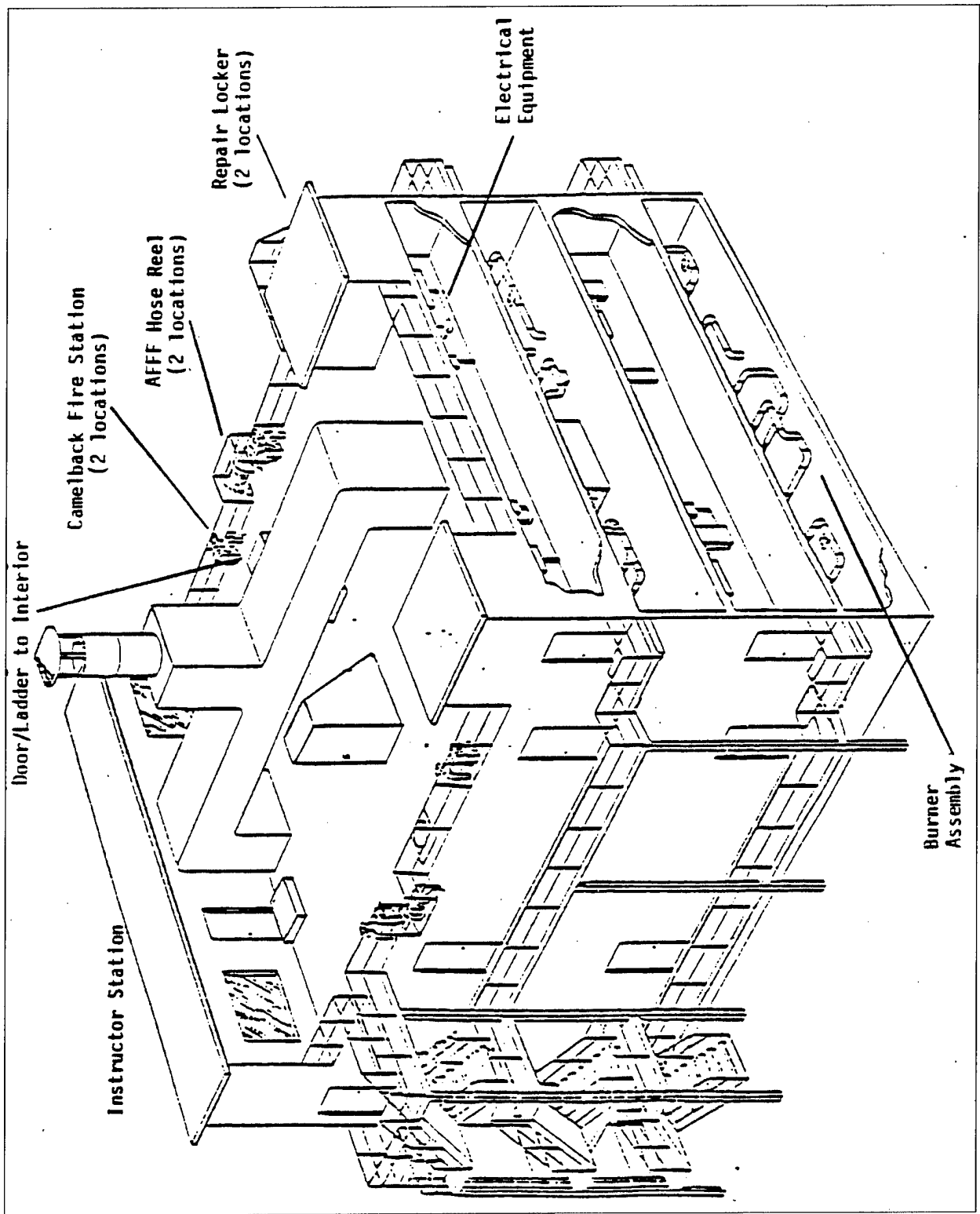

Figure 1-1. 19F1A Advanced Fire Fighter Trainer.

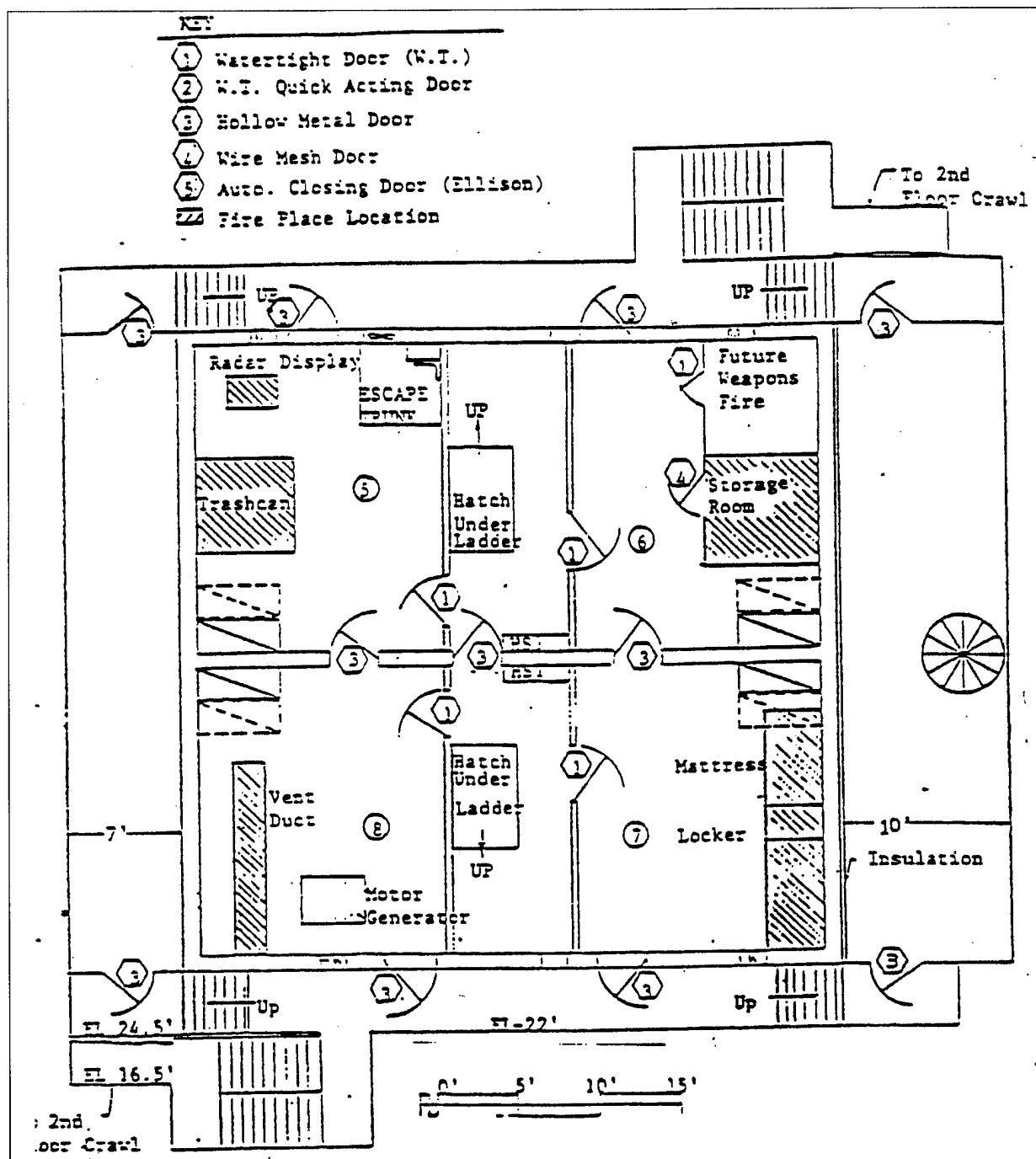

Figure 1-2. Upper floor fireplaces in 19F1A trainer.

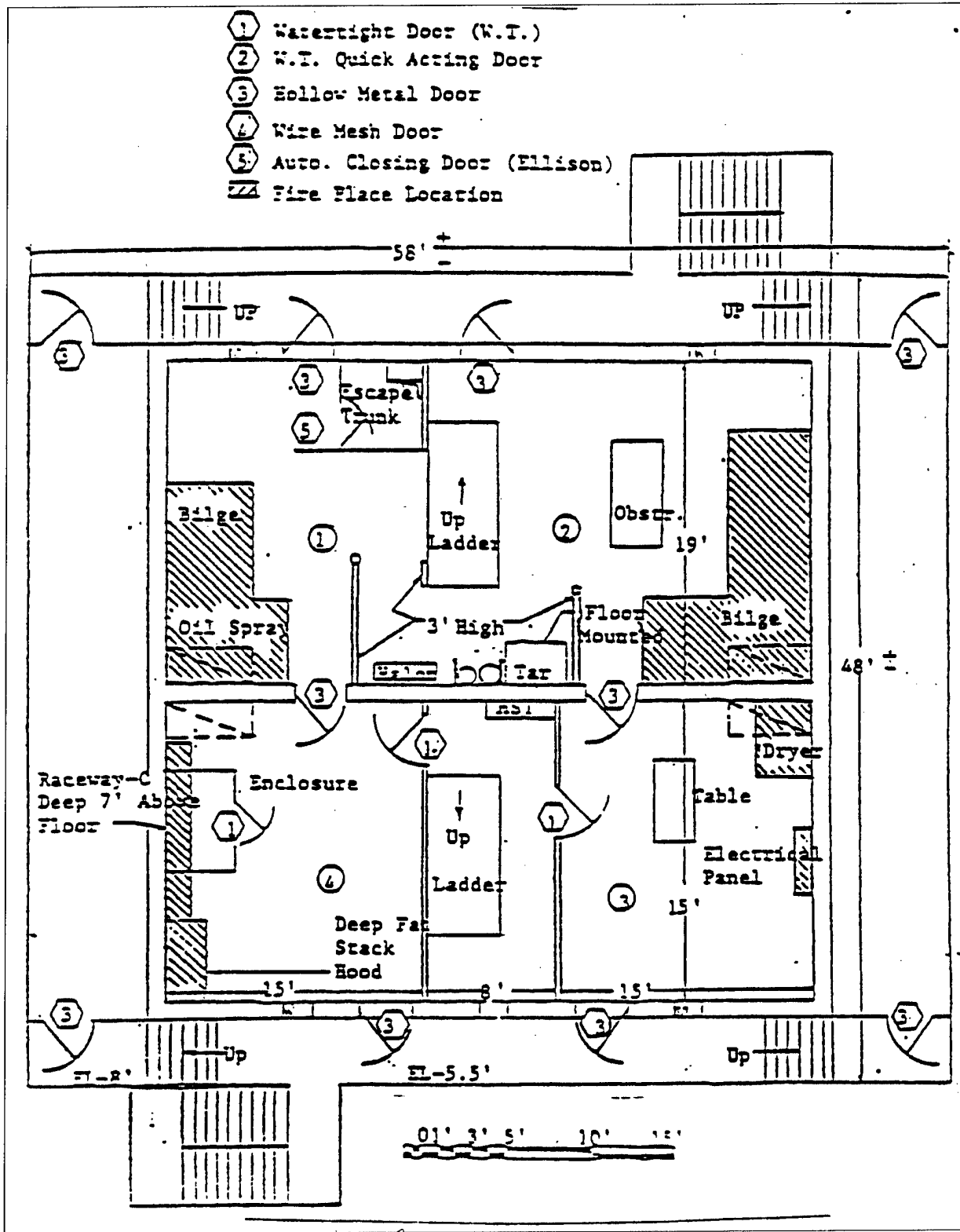

Figure 1-3. Lower floor fireplaces in 19F1A trainer.

## 1.4 OBJECTIVES

The objectives of this field demonstration test program were as follows:

- Determine whether 50-50 air-propane mixture can provide realistic flame appearance for training.
- Determine the ability of the air-propane mixture to reduce the emission of air pollutants.
- Determine what changes or modifications to the existing trainer systems are needed.
- Demonstrate the safety and operability of the equipment and design changes.
- Determine operation, maintenance, and life cycle costs.
- Document the results in a User Data Package (UDP) report.

## CHAPTER 2.0

### 2.0 SYSTEM DESCRIPTION

Several critical factors are addressed which include conceptual development, fabrication of an actual air-propane proportioning device system, and installation of the system. Criteria for major design, equipment selection, and operational considerations are:

- Safety of operation, maintenance, and storage
- Operational under all weather conditions without additional protection
- Infrequent and easily accomplished maintenance
- Long term durability
- Well engineered and commercially available spare parts
- Well-written installation and maintenance manuals
- Automatic operation
- Minimum adjustments after initial installation

The air-propane proportioning device as shown in Figure 2-1, is a commercial "standby" system that is designed to mix air and propane on demand to the same heating value per unit volume as natural gas. Tests described below demonstrate that adding this amount of air does not degrade the appearance of the flames, such as luminosity and radiation heat.

The proportioning device tested was designed by the manufacturer to stand up in an open space without the need of shelters or other protection. The device is expected to operate automatically and is equipped with a number of safety devices to guard against any dangerous hazards or off-standard condition. The manufacturer's operation and maintenance manuals are provided as Appendix C.

The commercial air-propane proportioning device is for industrial use and can switch to an air-propane mixture if the supply of the natural gas is interrupted.

The proportioning device may be fully automatic. When the pressure in the natural gas main falls, the proportioning device furnishes an air-propane mixture. The proportioning device may be set so that this air-propane mixture has the same volumetric heating value as the natural gas. The mixture will not explode because it has less than 1/5 of the air necessary to reach the rich limit of flammability. Despite the fact that the gas density is somewhat different than the natural gas, the furnace burners or other devices at the industrial plant continue to operate normally.

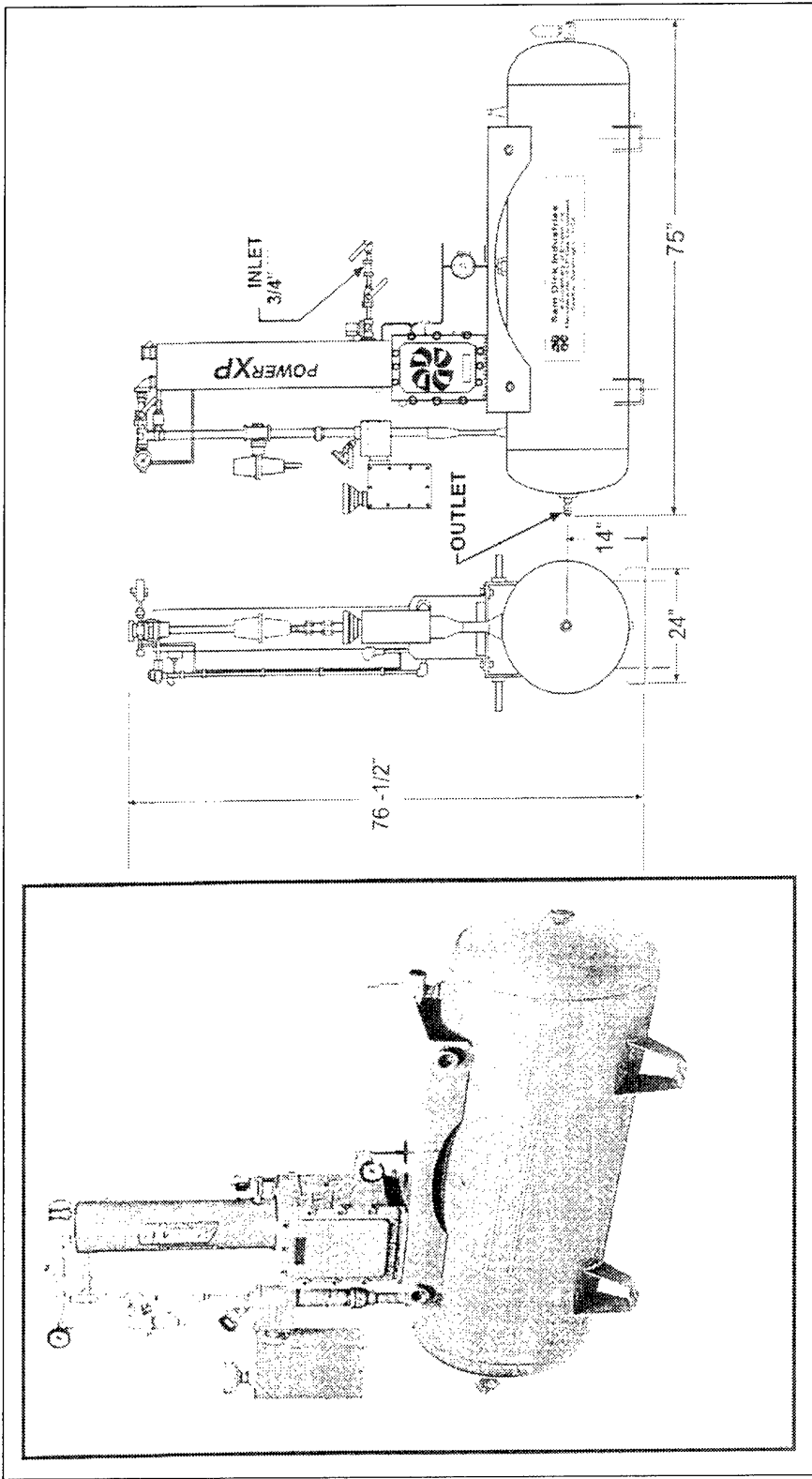

Reprinted with permission from Algas-SDI International, LLC,

Figure 2-1. "Standby" air-propane mixing system.

Several manufacturers make applicable “standby” equipment. The current edition of the “Thomas’ Register” lists 13 companies that manufacture this kind of equipment as shown in Table 2-1 (Thomas’ Register, 1998).

Table 2-1. List of Manufacturers of Air-Propane Proportioning Devices

<b>Manufacturer</b>	<b>Phone Number</b>
Sam Dick Industries, (subsidiary of Eclipse Co.)	1-800-959-0270
ALGAS Industries Inc.	1-972-686-7455
RANSOME Mfg.	1-800-342-0979
GAS PLANTS INCORPORATED	1-800-432-8538
ALTERNATE ENERGY SYSTEMS	1-770-487-8596
Thomas Associates Inc.	1-908-771-9100
CHESMONT Engineering Company, Inc.	1-800-221-5174
TOTAL ENERGY CORP.	1-914-682-0181
PLANT SYSTEMS INC.	1-800-235-3925
ELY ENERGY	1-918-250-6601
ENGINEERED SYSTEMS	1-800-948-2489
SYSTEMS CORP.	1-800-832-7818
A TECH Equipment, Inc.	1-770-487-7899
Combustion Services, Inc.	1-800-878-5535
MAXON	1-317-284-3304

The proportioning device selected for this project was the XPV 2.5 model manufactured by Sam Dick Industries. The U.S. Navy does not intend to endorse or advertise any specific manufacturers products.

## **2.1 INTRODUCTION TO THE EQUIPMENT**

The XPV Liquefied Petroleum Gas (LPG) vaporizing/mixing system is a self-contained unit that provides a mixture of LPG with air to replace natural gas. This system is explosion-proof, compact, and portable so that it can be installed almost anywhere. The system is quiet, reliable, safe, and automatic. The system has built in solid state electronics that controls the mixing process simple and easy. An accumulator tank enables the venturi to cycle on and off to meet the required load demand.

## **2.2 DESCRIPTION OF THE EQUIPMENT**

A photograph of the equipment including propane tank, air mixer, and burner is shown in Figure 2-2. A 1,000-gallon propane tank is shown in Figure 2-3. The major component drawings are shown in Figures 2-4 and 2-5.

Sam Dick Industries manufactures various sizes of vaporizer/mixer systems with heating output ratings from 2.5 to 28 million Btu and delivery pressures from 5 to 12 psig. The field tests described here were conducted with the XPV 2.5 model, which provides enough air-propane mixture for two trainer bilge fireplaces, simultaneously. A larger size of vaporizer/mixer system would be needed for a larger demand. For use in the fire fighting trainers, the pressure in the surge tank is increased to 16.5 psig by adjusting the screw in the control box (item 1 in Figure 2-4).

The XPV 2.5 model uses an electric vaporizer to vaporize the propane. The propane gas is mixed with air in the venturi and the air-propane mixture is stored in the accumulator tank. The accumulator tank serves as a reservoir that provides uninterrupted flow of mixed air-propane gas from full flow to no flow, automatically. All XPV models are designed and fabricated as explosion-proof and meet the requirements of Class I, Division 1, Group D as defined by National Fire Protection Association (NFPA) pamphlets 58 and 70 (National Fire Code 1998 and 1999). This classification allows installation almost anywhere (no protection from the elements or sources of ignition is required) with minimum clearances for convenient installation. The components are identified in Table 2-2.

The system can be operated either automatically or semi-automatically. The operational sequence of the system is outlined as follows:

- Turn on the electricity
- Open the hand-valve of liquid propane inlet
- Open the hand-valve of gas discharge outlet
- Press the "start" switch
- Run the system

If the propane tank temperature is low and the vapor pressure is less than 124 psig, a liquid propane booster pump will be turned on automatically. A solid state control system controls all operations and continuously monitors the safety of the system. When the system is turned on, mixed gas will be available immediately. If the system is turned off, it will take less than 1 minute after the start switch is pressed to provide gas at full flow.

The power requirements of the vaporizer/mixer systems are 240V alternating current (AC), 3 phase, 30 amperes. In addition, the pump requires 240V AC, 3 phase, 3.6 amperes separately.

The vaporizer/mixer system weighs approximately 800 pounds, and the pump weighs approximately 150 pounds. The manufacturer states that the combination of explosion-proof vaporizer and venturi, and solid state control system make the XPV 2.5 system completely safe and reliable regardless of the installation site.



Figure 2-2. Propane tank, air mixer, and burner at MFRI.



Figure 2-3. 1,000-gallon propane tank.

# MAJOR COMPONENTS DRAWING

MODEL: 2.5 - 5# & 8#; MODELS: 5.0 THROUGH 10.5 - 5#, 8#, 12#; MODEL: 9.0 - 12#

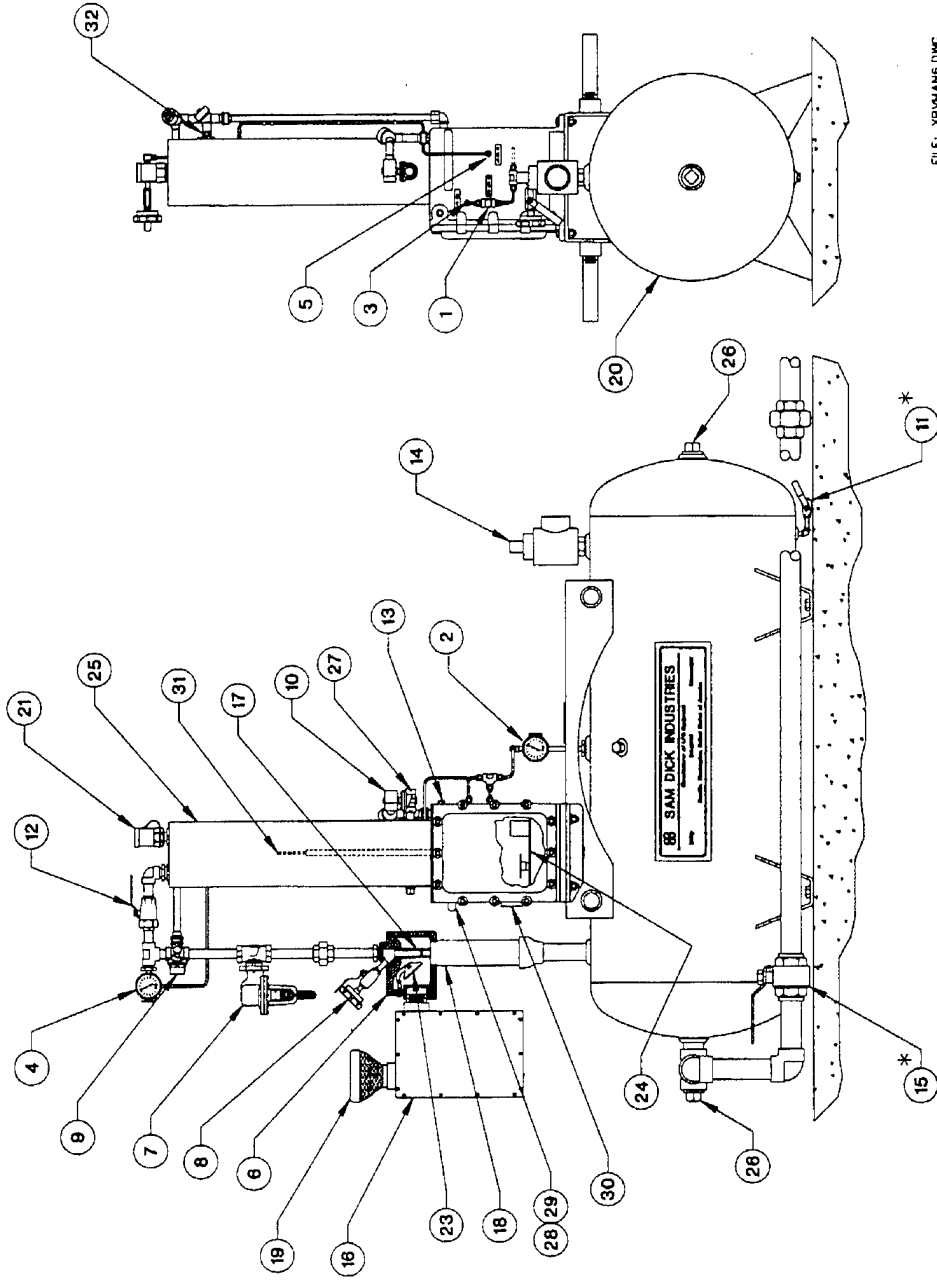

Note: See Table 2-2 for legend

Reprinted with permission from Algas-SDI International, LLC

Figure 2-4. Major components drawing.

# TYPICAL OPERATION OF XPV VAPORIZER/MIXER SYSTEM

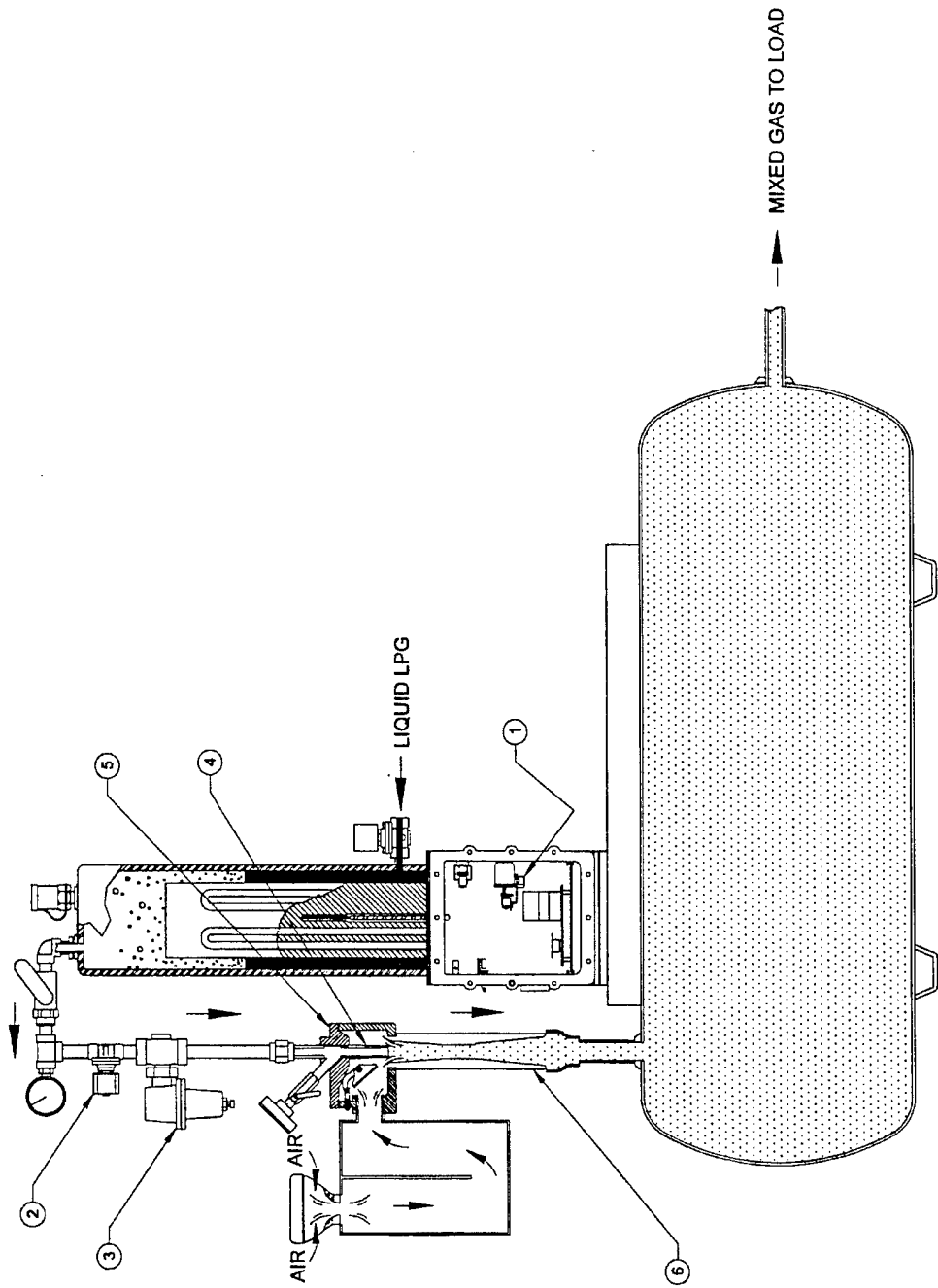

Reprinted with permission from Algas-SDI International, LLC

Figure 2-5. Detail of XPV vaporizer/mixer system.

Table 2-2. XPV Major Component Identification

Item Number	Description
1	Venturi Pressure Switch
	A. "On" pressure adjustment B. "Off" pressure adjustment
2	Mixed Gas Pressure Gauge
3	High Tank Pressure Switch
4	Inlet Vapor Pressure Gauge
5	Low Vapor Pressure Switch
6	Venturi Housing Assembly
7	Venturi Vapor Pressure Regulator
8	Venturi Motive Pressure Gauge
9	Venturi Vapor Solenoid Valve
10	Inlet Safety Solenoid Valve (closes with tank over-pressure)
11	Accumulator Tank Drain Valve (by others)
12	Venturi Shut-off Valve (vaporizer outlet shut-off valve), Isolation Valve
13	Control Box
14	Accumulator Tank Relief Valve
15	Mixed Gas Discharge Valve (by others)
16	Air Intake Silencer
17	Nozzle
18	Diffuser
19	Air Inlet
20	Mixed Gas Accumulator
21	Vaporizer Relief Valve
22	Accumulator Tank Mixed Gas Discharge Pressure Adjusting Screw
23	Air Intake Check Valve Assembly
24	Control Board Assembly
25	Vaporizer
26	Inspection Opening
27	LPG Inlet
28	Start Button
29	Stop Button
30	Electric Supply Connection Point
31	Vaporizer Temperature Sensor
32	Vaporizer Liquid Level Switch
33	Time Delay Relay
34	Venturi Control Circuit Transformer
35	Auto Restart Module
36	Toggle Switch

### **2.3 THE VAPORIZER**

The vaporizer, shown in Figure 2-5, is composed of multiple heating elements imbedded in a finned aluminum heat exchanger core. An RTD temperature sensor and a solid state control system maintain the heater core temperature from 200° to 210°F. Liquid propane enters the vaporizer through the inlet solenoid valve and comes in contact with the heater core. The liquid propane is then heated up to become propane gas. When the temperature of the heater core falls below a preset minimum temperature, the control system turns the heater on. The control system also contains the logic to shut off the system if an unsafe or overheating condition exists.

### **2.4 THE MIXER**

The pressure of the propane vapor closes the “low vapor switch” which is shown as item 5 in Figure 2-4 in the control box. After an initial time delay, the control box activates the venturi control circuit and opens the venturi solenoid valve which is shown in item 9 of Figure 2-4. The propane vapor is fed through a pressure regulator and then through the venturi nozzle.

This propane vapor flow creates a pressure lower than atmospheric pressure in the venturi housing. As a result air flows in through the silencer. The air and the propane vapor are mixed in the diffuser section, and pressurized in the accumulator tank. When the air-propane mixture in the accumulator tank reaches a preset pressure level, the venturi solenoid valve closes.

After the air-propane mixture in the accumulator tank is used, the following three steps will occur to resupply the air-propane mixture:

- The pressure inside the tank drops
- The venturi control switch closes
- The venturi solenoid valve opens resupply air-propane mixture to the accumulator tank

Results of these three steps will automatically

### **2.5 THE CONTROL BOX**

The control box, as shown in Figure 2-6 contain:

- A contractor that supplies current to the vaporizer elements
- Push button switches to turn the unit on and off
- A timer
- Several pressure switches that control solenoid valves, and

- A transformer to supply current to the electrical switches and solenoids.

The control box is built in an explosion-proof container. The control box does not have any explosive materials within the device. Propane leaks may occur outside the control box, but the only potential ignition sources in the apparatus are inside the box. So propane leaks in the system cannot be ignited by any of the components of the system.

## **2.6 THE LPG LIQUID PUMP**

The liquid line pressure supplied to the vaporizer must be high enough for the venturi to meter the flow of air accurately and still develop enough static pressure in the diffuser to fill the accumulator tank. For an accumulator tank pressure of 14 psig, the liquid line pressure must be at least 123 psig. In warm weather, the propane vapor pressure in the storage tank may be this high, but it will be lower in cold weather. So a liquid pump must be installed to provide adequate liquid line pressure.

The pump package selected was the "Stabilaire," BS1 model (Figure 2-7). The Stabilaire is manufactured by Sam Dick Industries and is compatible with the XPV 2.5 vaporizing/mixing system. It contains a positive displacement pump driven by an explosion-proof electric motor. Again, the explosion-proof motor housing, and electrical housing are not to protect the equipment, but to prevent ignition of any propane leaks.

The output pressure is set by a regulator that bypasses liquid back to the storage tank when the output pressure exceeds the set pressure. This process limits the output pressure to the set point of the regulator. This bypass system is normally in operation, since the pump is capable of supplying more liquid propane than the maximum amount needed by the vaporizing/mixing system. The pump package also has a bypass system that allows liquid to flow directly from the storage tank to the vaporizing system if the vapor pressure in the storage tank is high enough that the pump is not needed. The pump body has an internal bypass to prevent damage to it if the return line is blocked. The pump components are identified in Table 2-3.

The pump package also contains the electrical components to operate the motor (a manual starter), valves, check valves, gauges, and a relief valve for safe and flexible operation. The relief valve opens if liquid is trapped in the plumbing (due to closed valves) and the pipes are heated, for instance, by sunlight. A strainer is provided to protect the pump from ingesting any solid material in the LPG supply line. An automatic motor starter can be made available to turn the pump on if the propane line pressure is too low to operate the vaporizer/mixer. The pump is capable of continuous use.

The pump is designed for easy maintenance. It has replaceable end disks, vanes, casing liners, and seals which can be easily replaced with basic tools. The sliding vanes are self-adjusting and maintain their efficiency throughout their life. The pump motor operates on 240V, 3 phase electrical current. If the motor turns in the wrong direction, simply switch any two conductors (performed at installation, only).

**MAJOR COMPONENTS DRAWING - CONTROL BOX**  
**MODELS 2.5 THROUGH 28.0**

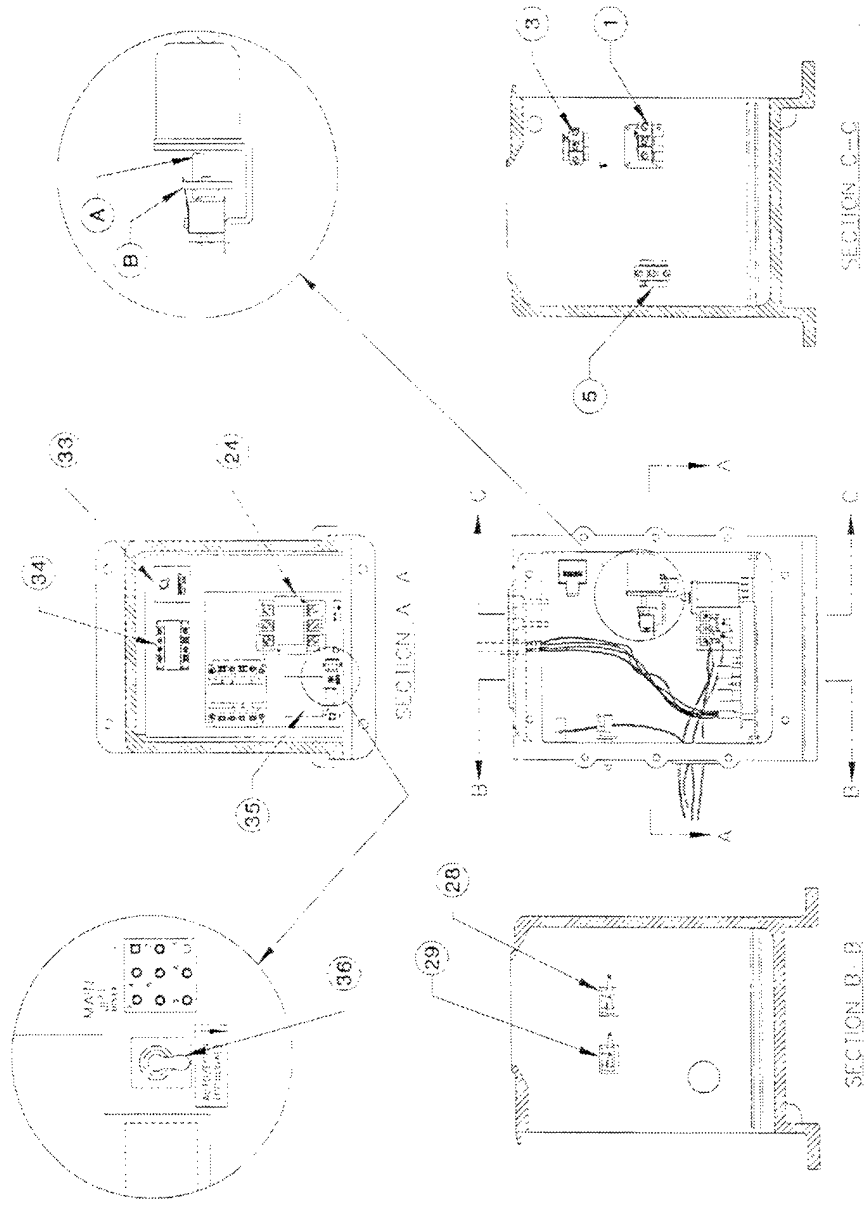

Notc: See Table 2-2 for legend

Reprinted with permission from Algas-SDI International, LLC

Figure 2-6. Detail of control box.

**COMPONENT DRAWING - BS1 AND BS-1 1/2**

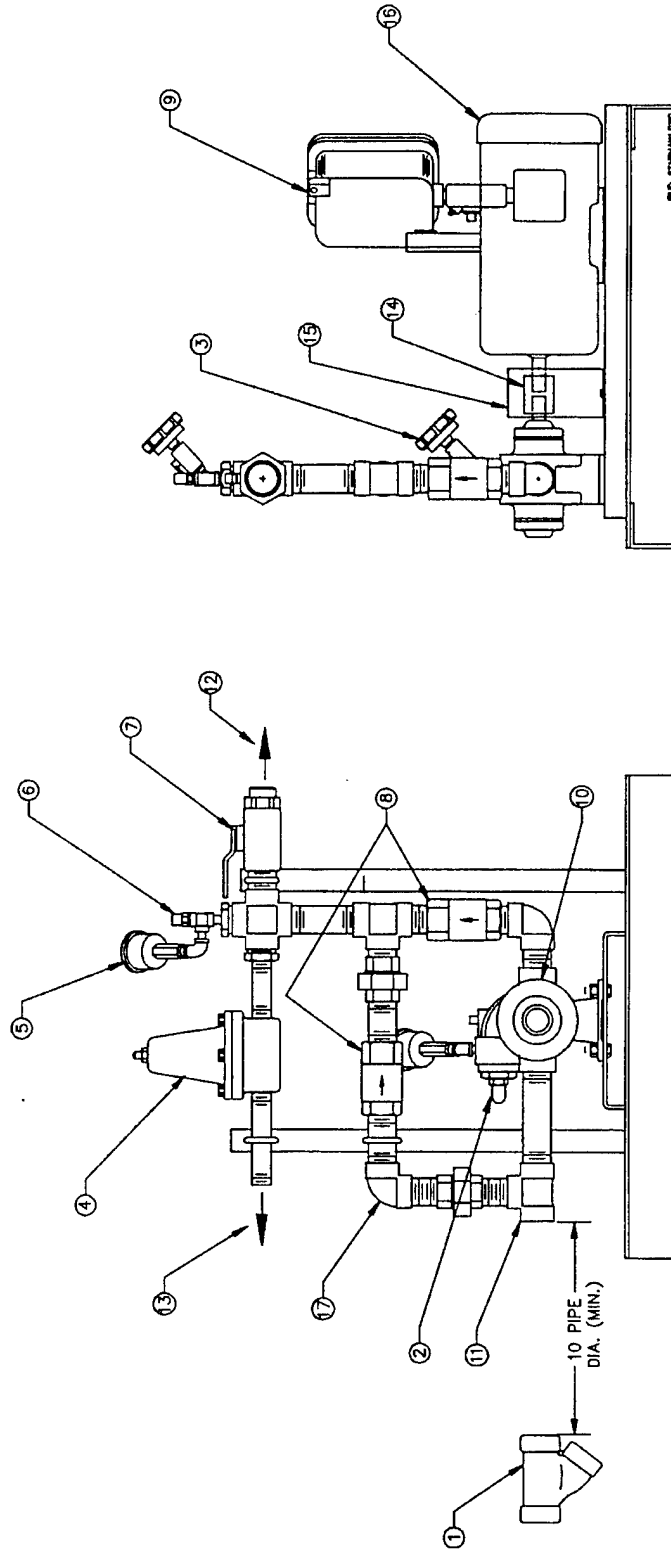

Note: See Table 2-3 for legend

Reprinted with permission from Algas-SDI International, LLC

Figure 2-7. Liquid propane pump.

Table 2-3. Liquid Propane Pump Components

Item Number	Description
1	LPG Inlet Strainer
2	Internal Relief/Bypass Valve
3	LPG Inlet Pressure Gauge
4	Back Pressure Control Valve
5	LPG Outlet Pressure Gauge
6	Hydrostatic Relief Valve
7	Outlet Isolation Valve
8	Check Valves
9	Starter Switch
10	Pump – positive displacement sliding vane type
11	LPG Inlet
12	LPG Outlet
13	LPG Excess Return
14	Coupling Guard
15	Coupling Between Motor and Pump
16	Explosion Proof Electric Motor
17	LPG Bypass

## CHAPTER 3

### 3.0 INSTALLATION

As previously mentioned, the equipment chosen for this demonstration is designed to operate outdoors and does not require protection from the weather. This was demonstrated by operating it in an open parking lot from time-to-time during the winter at the Maryland Fire and Rescue Institute (MFRI) at the University of Maryland.

This equipment can be used at an existing FFTF. The vapor line from the accumulator tank will be attached to the 4-inch gas line feeding the trainer, downstream of the "Block and Vent" setup (located outside the trainer building). The Block and Vent hand valves will be left closed. It is possible that a software patch will be needed to operate the trainer with the Block and Vent closed. Liquid propane must be provided to the equipment. It was planned to use a liquid propane tank provided by the propane supplier for this demonstration. The tank outlets (liquid and gas) are typically large enough for 3/4-inch standard pipe, and 5/8-inch copper tubing, which has been found to be large enough to service the equipment. Since the 5/8-inch tubing used in the return line is subjected to vapor pressures as high as 200 psi in the summer, it is recommended that this tubing be a stronger grade, which has double the wall thickness of refrigeration grade tubing.

For permanent installation, the equipment will be fed with liquid propane from the existing tanks, as shown in Figure 3-1. In this case, the electrically driven pump would be located close to the propane storage tanks and liquid propane pumped to the vaporizer/mixer. Locating the pump close to the storage tanks facilitates the installation of the vapor return line to the gas space above the liquid in the tanks, and placement of the pump to obviate gas bubbles in the pump inlet line. The existing vaporizer(s) on the fuel tanks would not be needed since the vaporizer/mixer has an electrically heated vaporizer.

# TYPICAL INSTALLATION DRAWING

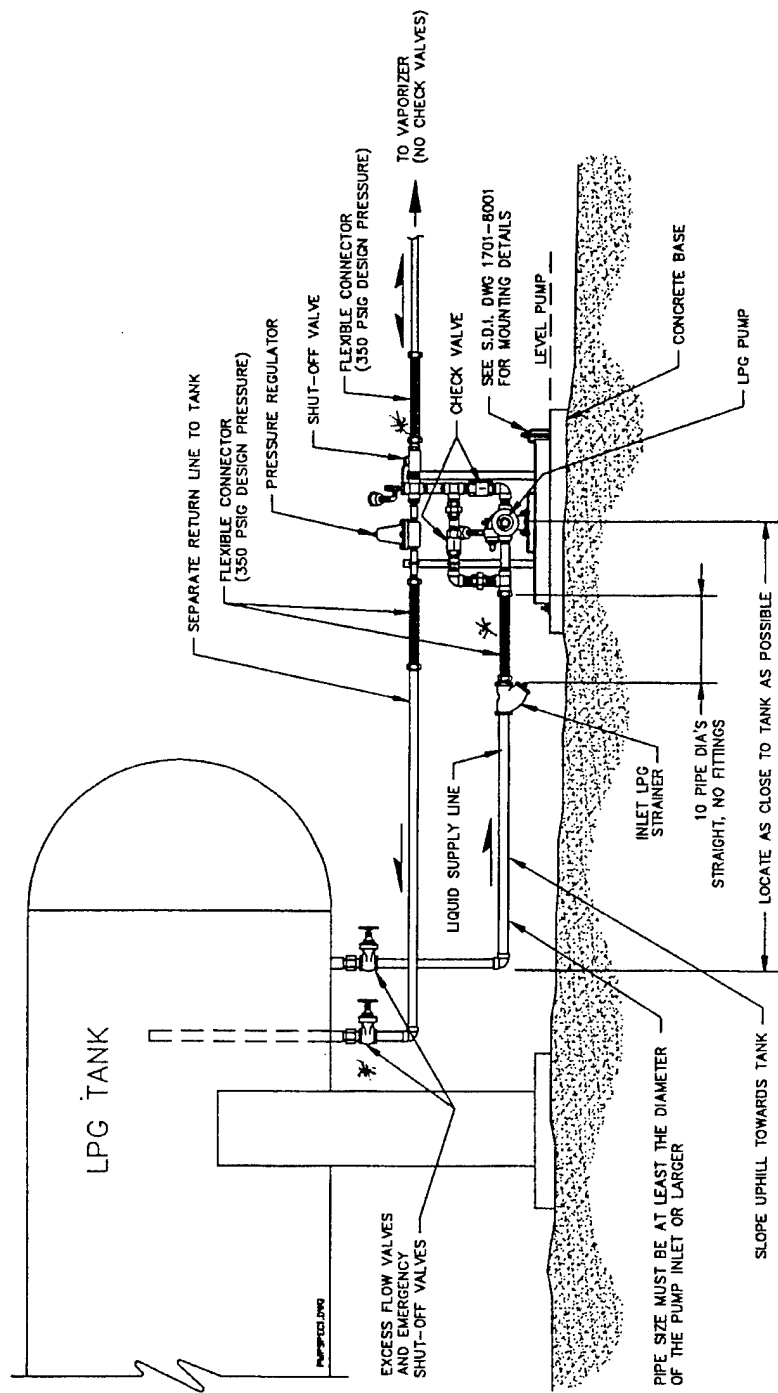

NOTES:  
 INSTALLATION MUST MEET NFPA58 AND 70 OR  
 OTHER APPLICABLE CODES.

Reprinted with permission from Alaaq-SDI International, LLC

Figure 3-1-1. Installation of liquid propane pump.

## CHAPTER 4.0

### 4.0 EXPERIMENTAL RESULTS

#### 4.1 FLAME APPEARANCE

A series of tests on the flame appearance were conducted in a laboratory under field conditions. The results of the observations are documented in the following sections.

##### 4.1.1 Laboratory Flames

The initial experiments were run indoors, inside a laboratory. The burner used in the initial laboratory experiments was one of the four segments of a full size bilge burner from a decommissioned 19F5 Navy (recruit) fire fighting training facility. Tests were carried out in the "Potomac" laboratory of the University of Maryland. The experimental arrangement is shown in Figures 4-1 and 4-2. In order to reduce the fire extent to meet laboratory capabilities, 80 percent of the burner holes were plugged, but the remaining holes were grouped as originally designed for the burner. This meant that the flame appearance and vertical extent would be the same as the original burner except the horizontal extent of the fire (and fuel flow) was reduced by 80 percent. With this change, the maximum gaseous propane flow rate that did not cause noisy flame turbulence (or a change in flame appearance) was 150 standard cubic foot-per-hour (SCFH). So the total flow rate was held at 150 SCFH in all the initial laboratory tests described below, whether the fuel was pure propane, or 50-50 air-propane by volume.

Two large liquid propane cylinders supplied the propane (Figure 4-1). A compressor supplied the air. Both gases passed through rotameters. Throttle valves at the base of each rotameter adjusted both the air and propane flow. Mixing of air and propane gases occurred in a 5-foot long, 1-inch standard pipe that fed the burner. Figure 4-2 shows the burner segment, attached to the downstream end of the mixing tube.

Photographs of the flames were taken both facing the long side of the burner, and at right angles to the long side. Figure 4-3 shows the flame facing the long side with 100 percent propane. Figure 4-4 shows the flame with 50-50 air-propane mixture. The total flow rate is 150 SCFH in both cases.

Figure 4-5 was taken at right angles to the long side of the burner with propane only, and Figure 4-6 was the same view with 50-50 air-propane mixture.

As is seen in the photographs, the appearance of the yellow flames is the same in both cases, with or without air. In the photographs, the extent of the flame is less when the fuel is 50-50 air-propane, but this is not apparent to the naked eye. In fact, both flames appeared to be the same. An explanation is that the camera had a relatively short exposure, short enough to "stop" the tongues of flame. To the eye, these tongues were integrated into a continuous flame, and as stated above, the extent of the field of flame seemed to be about the same, with or without air addition.

There was concern that some of the equipment used in the FFTFs, for instance the pilot equipment, might require pure propane. However, the literature for the "flame pilot," shown in Figure 4-7, states that it will operate with a wide range of fuel heating values, so it should not be sensitive to the addition of air. Also, tests described in Section 4.2 of this User Data Package indicate the early "spark" pilot is not sensitive to the fuel heating value and works well with the 50-50 air-propane mixture.

Also, the temperature within the training compartment building will be reduced if less propane is burned. If there is a desire for training under heat up compartment the ventilation fan speeds and damper settings can be controlled to reduce airflow ventilation so the temperature in the training compartment building will not be decreased.

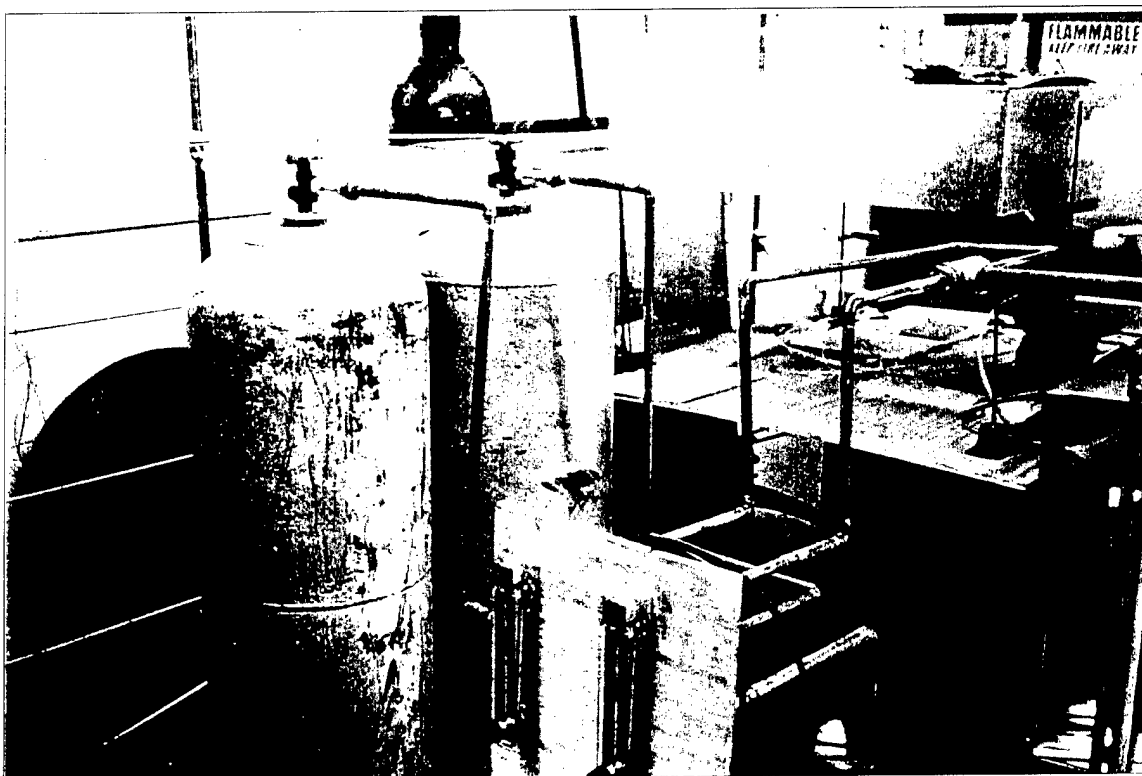

Figure 4-1. Propane feed system and rotameters.

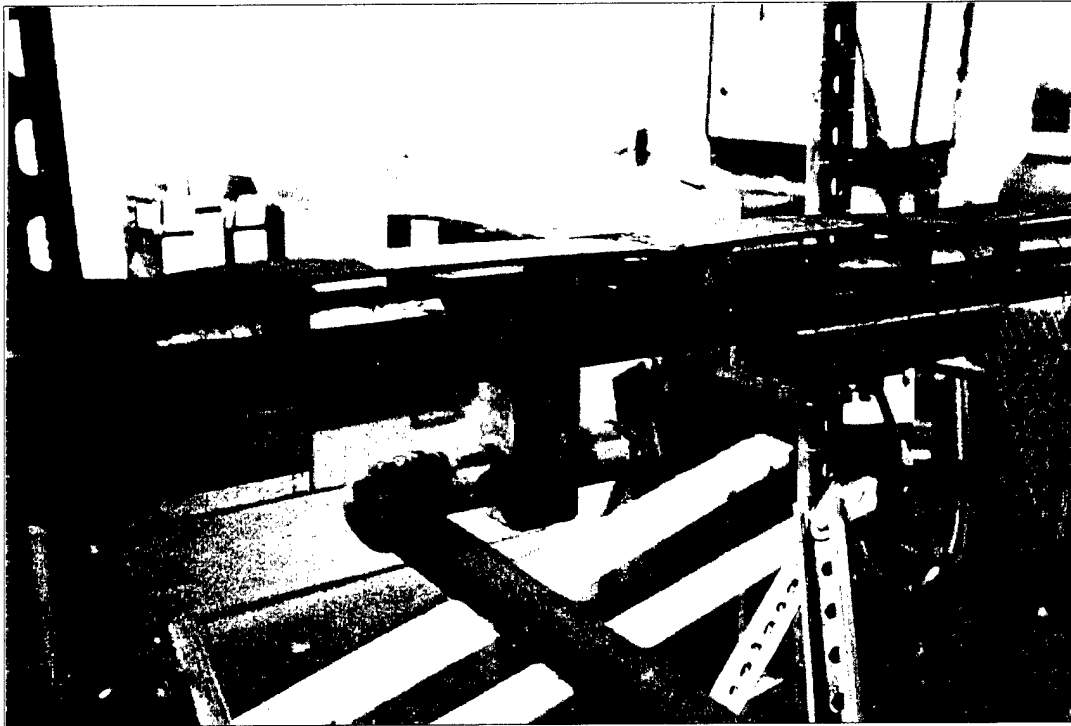

Figure 4-2. Bilge burner segment attached to mixing tube.

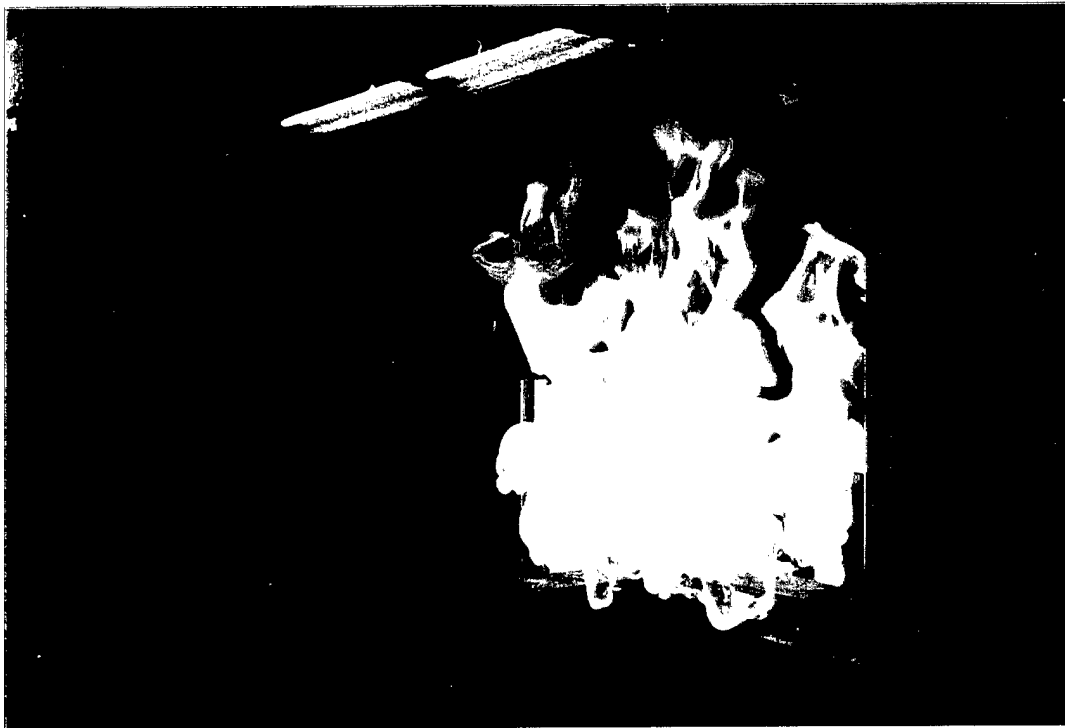

Figure 4-3. Flame along long side of burner, propane only.

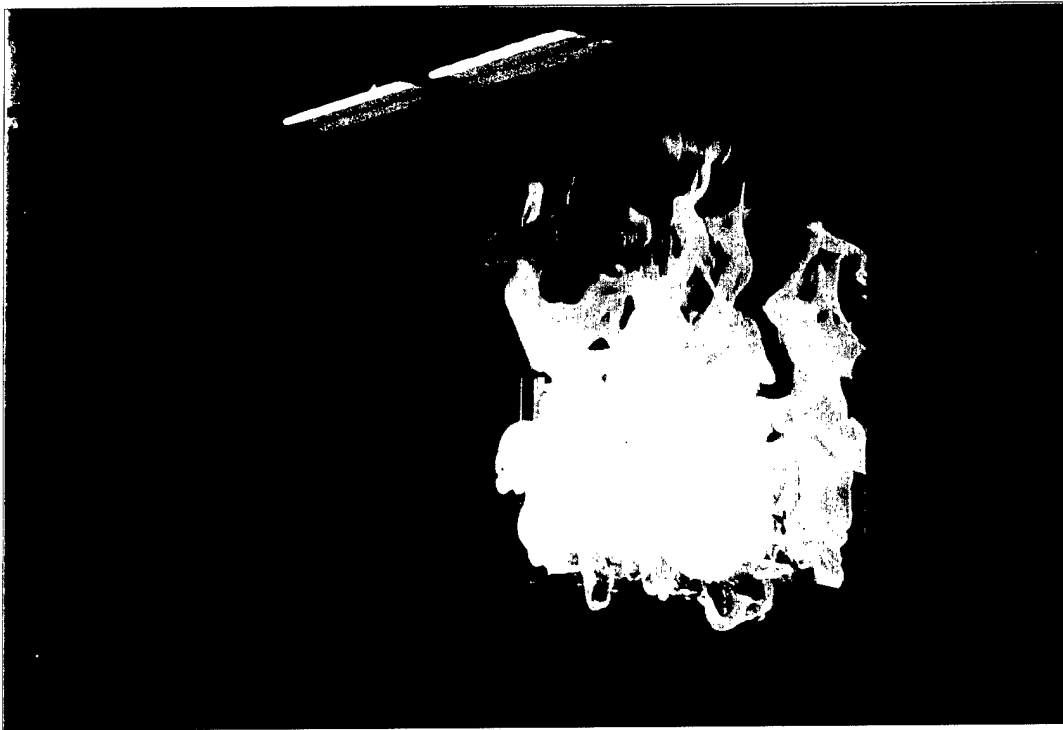

Figure 4-4. Flame along long side of burner, air-propane mix.

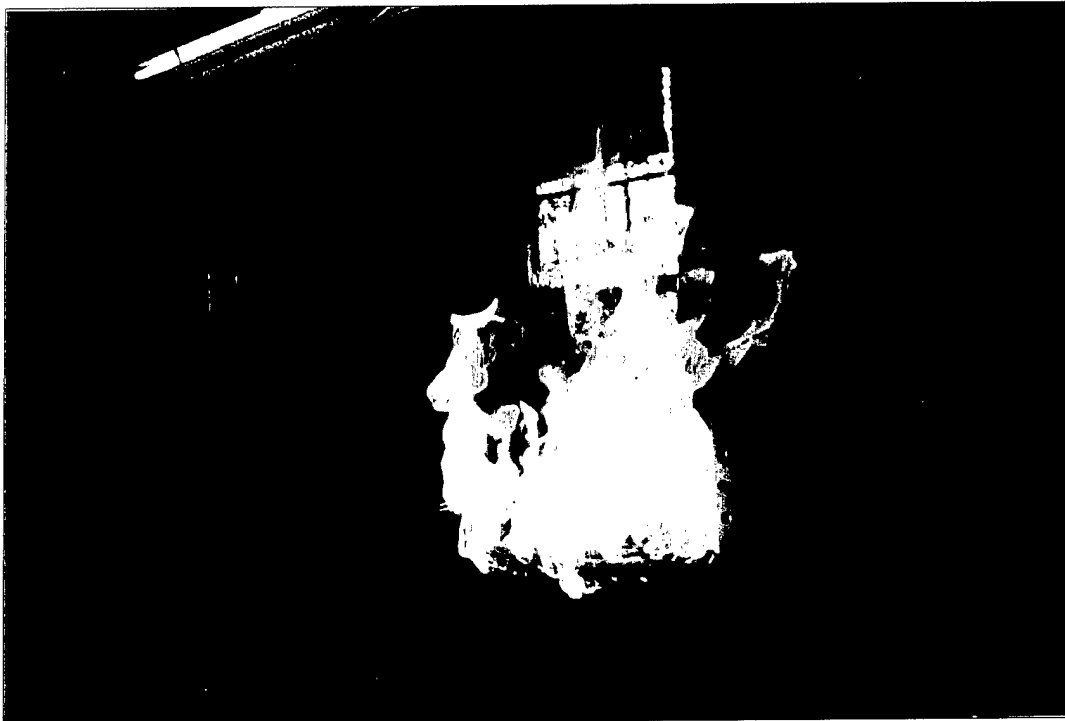

Figure 4-5. Flame along short side of burner, propane only.



Figure 4-6. Flame along short side of burner, air-propane mix.

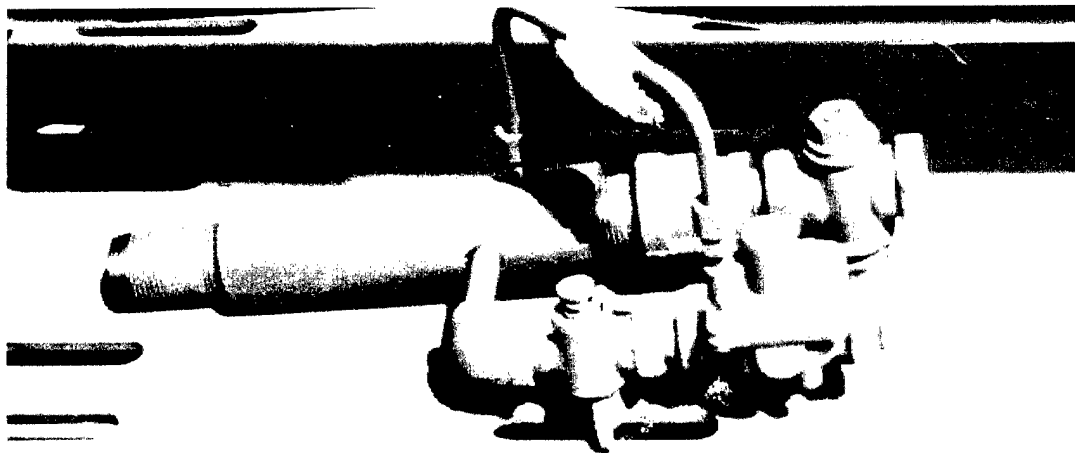

Figure 4-7. Eclipse Company nozzle, mixing pilot.

## 4.1.2 Full Scale Flames

**4.1.2.1 Apparatus.** The full size test was set up in the MFRI facility at the University of Maryland. The Sam Dick Industries XPV 2.5-15 model Standby LPG/air System used to mix the air and propane in approximately 50-50 by volume proportions is shown in Figure 4-8. When fuel of 100 percent propane was tested, the air intake on the device was closed with duct tape. When the air-propane mixture is withdrawn from the storage tank, the pressure inside the tank falls slightly, subsequently the device automatically resupplies more air-propane mixture. It is equipped with a complete set of safety devices.

The burner and pilot box are supported on cinder blocks in the same configuration as in a trainer, as shown in Figure 4-9.

Based on the measurements during laboratory testing, a flowmeter of a maximum flow rate of 100 standard cubic foot-per-minute (SCFM) was selected. Results of laboratory tests indicated that experience in these tests showed this range of the flow rates to be correct. At flow rates above 80 SCFM or below 30 SCFM, the flame did not resemble a bilge fire. The vane-type flowmeter is more sensitive to the flow of the denser propane than to the air-propane mixture. The actual volume of air-propane mix is about 94 percent of the metered volume per manufacturer's conversion factor of 0.94. This correction has been taken into account in the flow rates throughout the tests.

The burner was installed under a roofed shelter without side walls. Prior to testing, two wooden wind shields of 6 feet in height were added to one side of the burner to reduce the distortion of the fire by outdoor winds. The wooden shields were painted black to facilitate photography. In addition three horizontal white lines were painted at a vertical spacing of 1-foot. The lowest line is at the same level as the burner.

In these tests the pilot box is fed with the same fuel mixture as the burner. Provisions were made to feed air as well, as in the existing trainer. Both air and fuel flows to the pilot box were measured by rotameters.

**4.1.2.2 Flame Observation Tests.** A series of three tests were conducted to photographically compare the appearance of flames with the two fuels.

The first series of photographs were taken early in the morning without perceptible wind with an ASA 100 film in the camera. The results of photographs showed that exposure times longer than 1/8 second did not look like the flames seen by eye, but the 1/16-second or shorter exposures did appear realistic. So, photographs from this series are used in this User Data Package to compare the 50-50 air-propane with 100 percent propane; 80 SCFM flames with 40 SCFM flames, and 1/250-second and 1/16-second exposures.

Figures 4-10 and 4-11 show flames with 100 percent propane at 80 SCFM. Figures 4-12 and 4-13 show flames with 50-50 air-propane at 80 SCFM. The exposure settings for these were 1/250 second. The photos were taken at front and quarter-view angles to the burner. There

is some difference in the color of the flames, probably due to the angle of the sunlight, but to the eye the flames with the two fuels appeared identical.

Figures 4-14 and 4-15 (100 percent propane), and Figures 4-16 and 4-17 (50-50 air-propane mix) show similar results at a total flow of 40 SCFM. Figure 4-18 shows the flame of the 50-50 mix at 40 SCFM, but an exposure of 1/30-second, which gives a result similar to that seen by the eye. (Note: These photographs were selected because the flames were least affected by the wind. Even light winds caused the flames to become partly horizontal, despite the shields.)

**4.1.2.3 Conclusions of Flame Observation.** After viewing these photographs of full-scale flames, it is concluded that the visual differences between the flames of 100 percent propane and 50-50 air-propane mixture are small both in full-scale tests and laboratory tests.

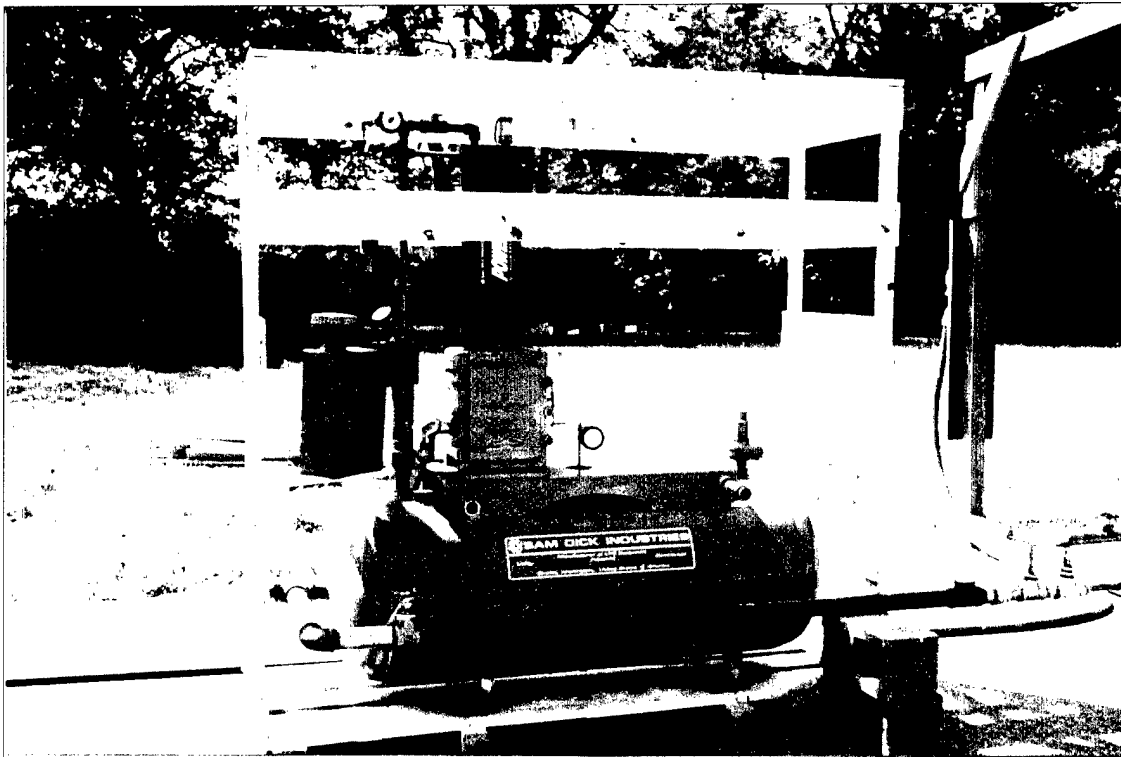

Figure 4-8. "Standby" air-propane mixing system.

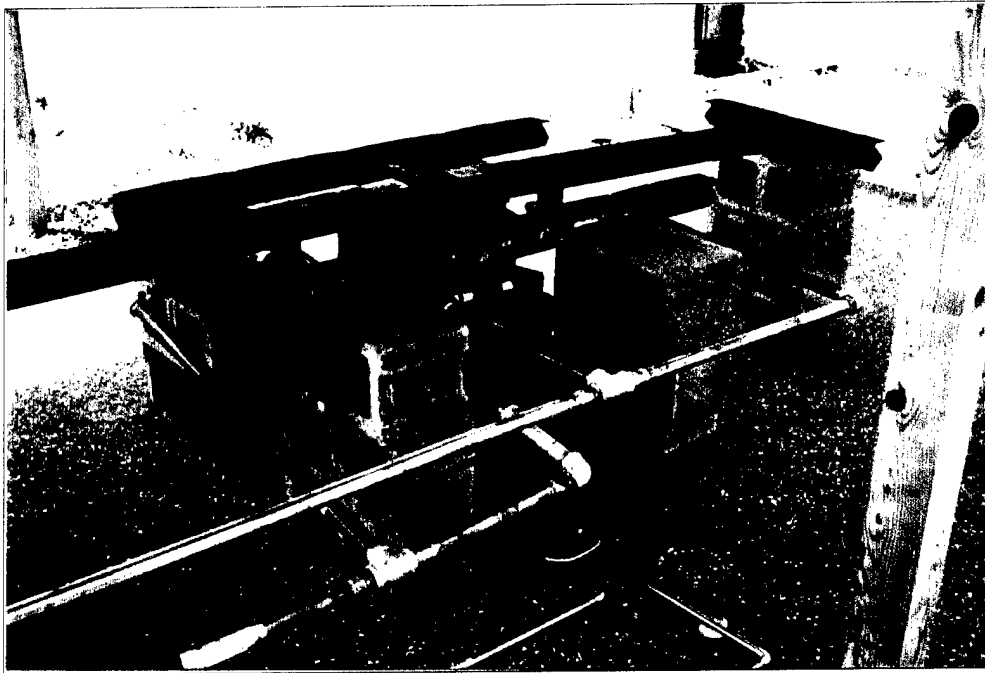

Figure 4-9. Bilge burner from 19F5 trainer.

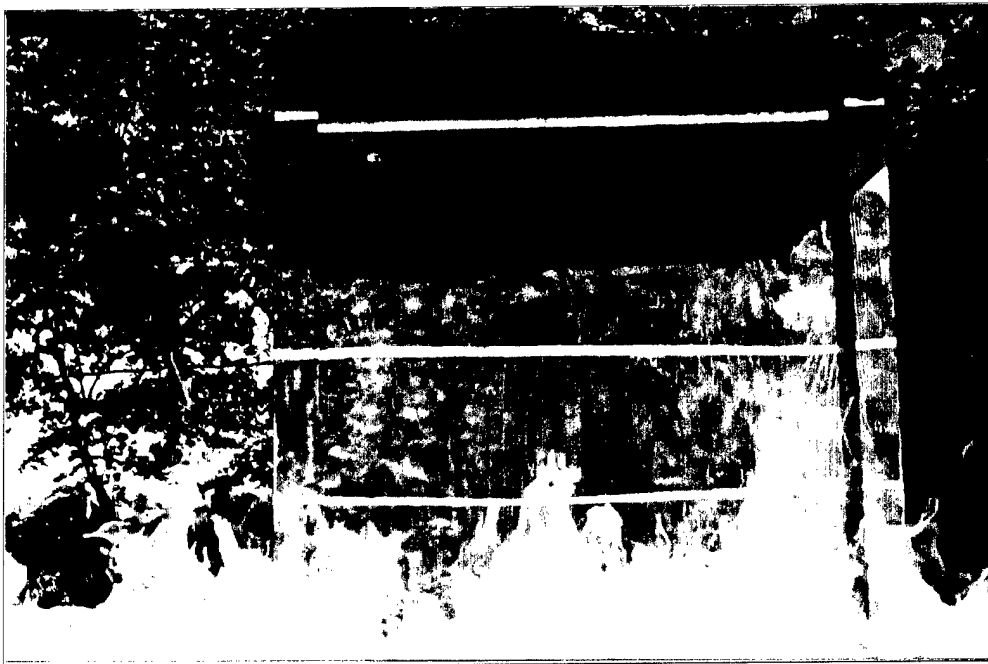

Figure 4-10. Propane fire at 80 SCFM, 1/500-second exposure.

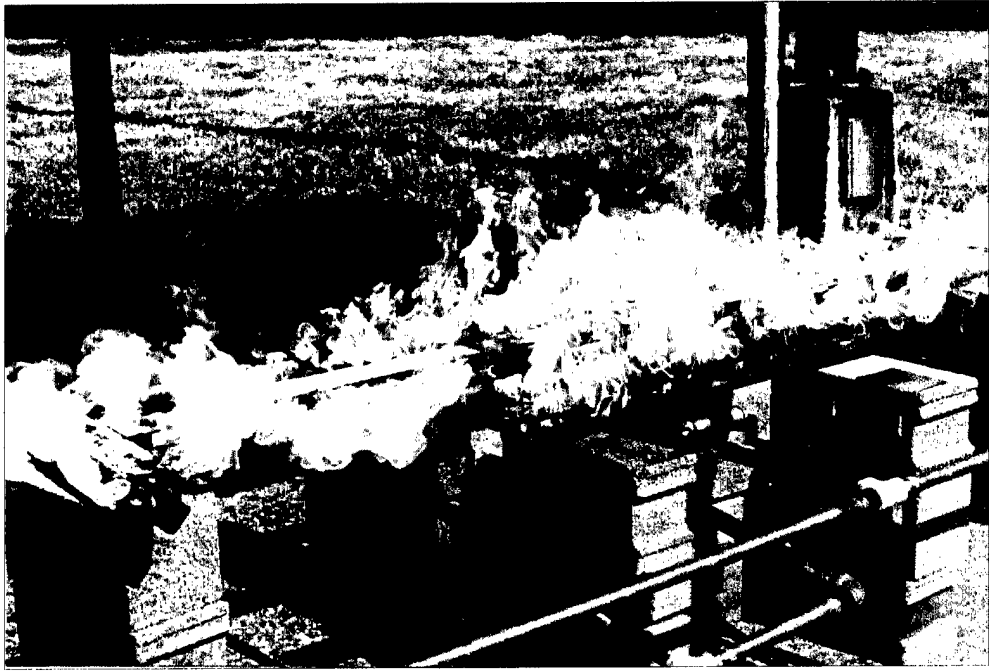

Figure 4-11. Propane fire at 80 SCFM, 1/250-second exposure.

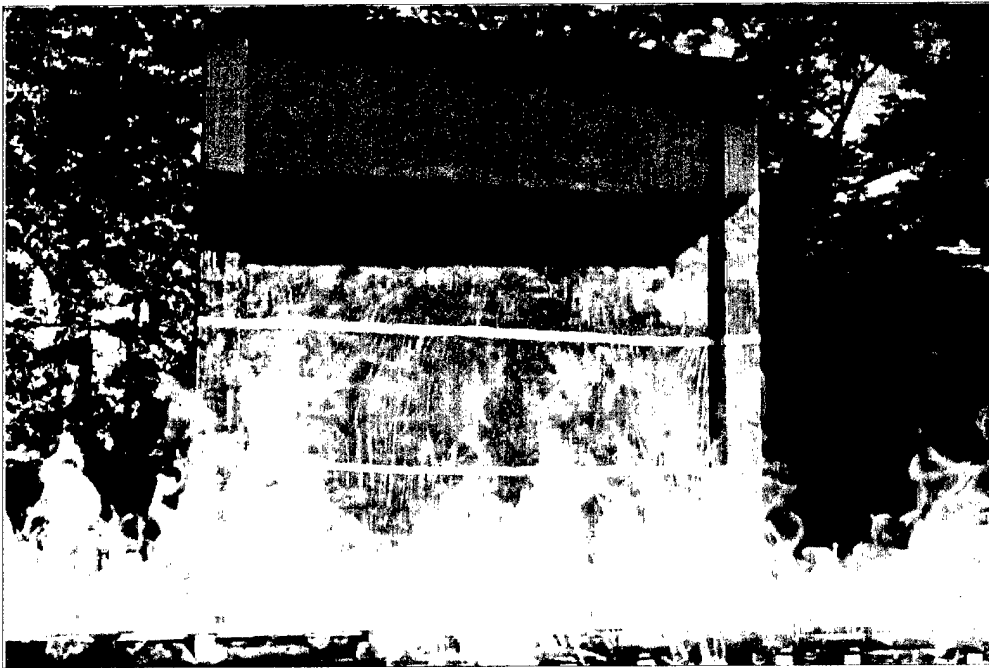

Figure 4-12. 50-50 air-propane fire at 80 SCFM, 1/250-second exposure.

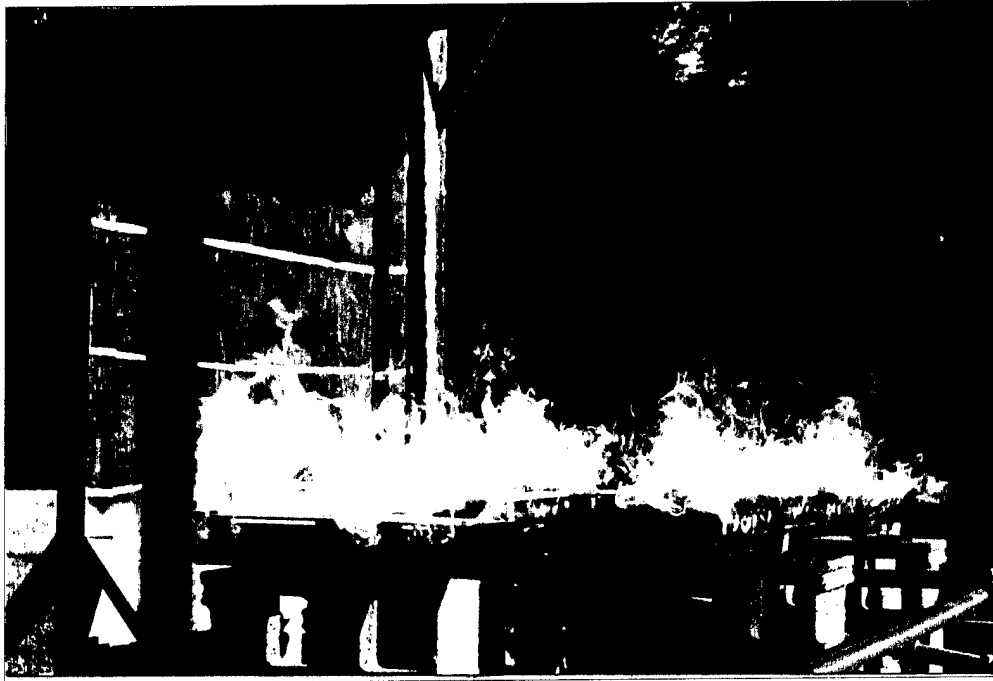

Figure 4-13. 50-50 air-propane fire at 80 SCFM, 1/250-second exposure.

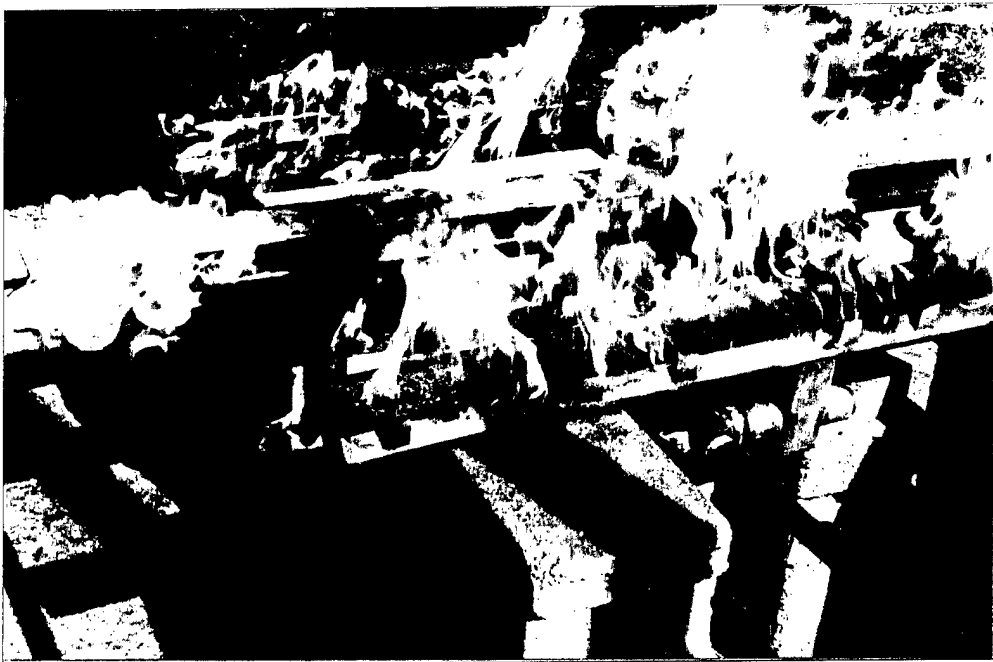

Figure 4-14. Propane fire at 40 SCFM, 1/250-second exposure.

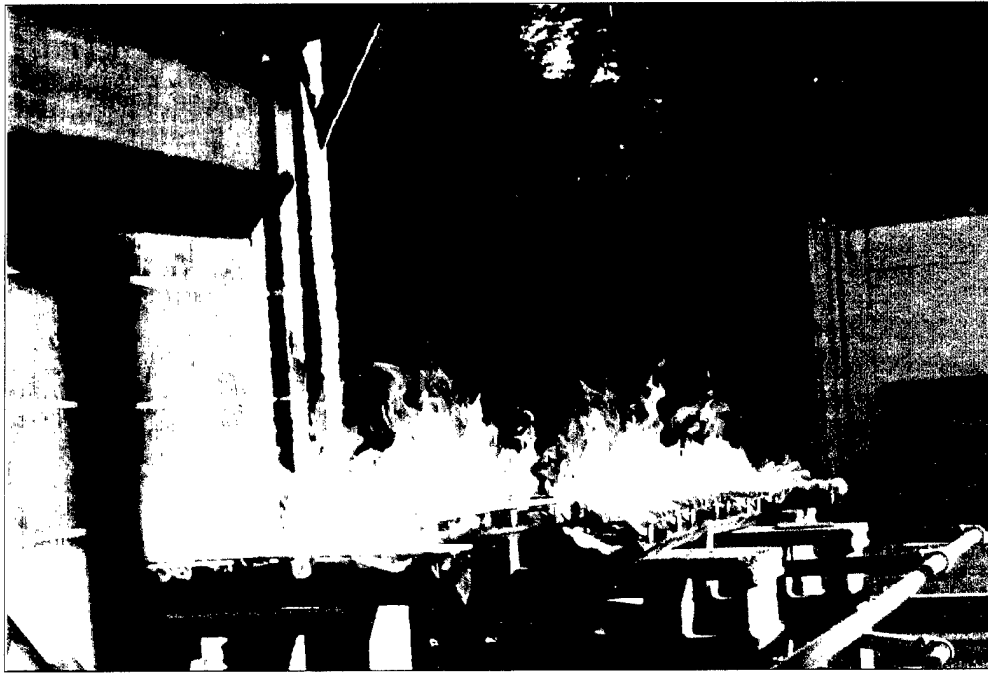

Figure 4-15. Propane fire at 40 SCFM, 1/250-second exposure.

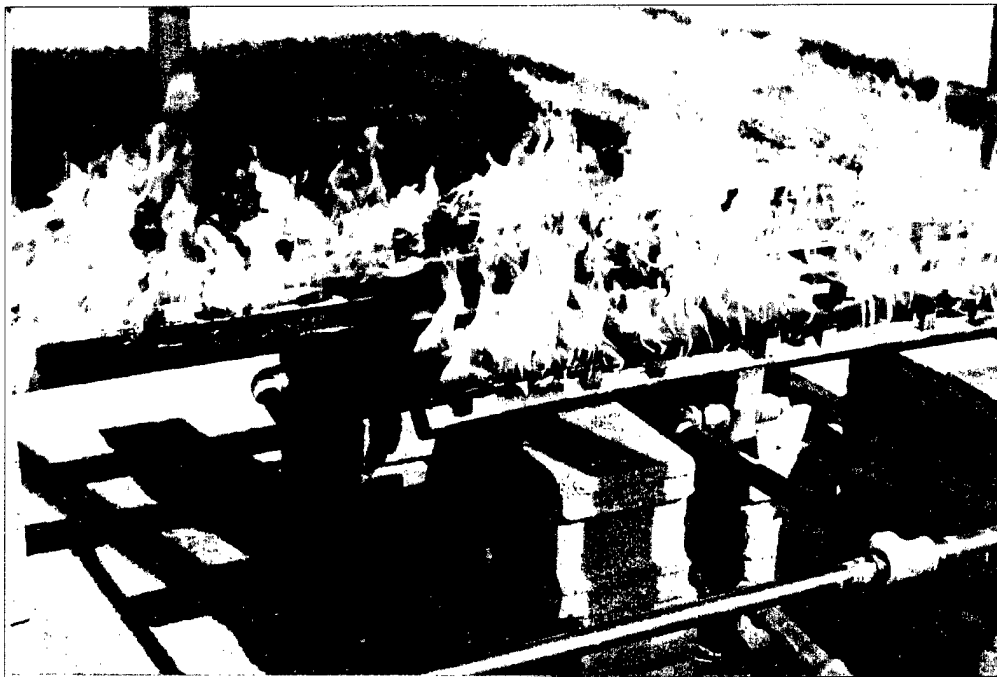

Figure 4-16. 50-50 air-propane fire at 40 SCFM, 1/250-second exposure.



Figure 4-17. 50-50 air-propane fire at 40 SCFM, 1/250-second exposure.

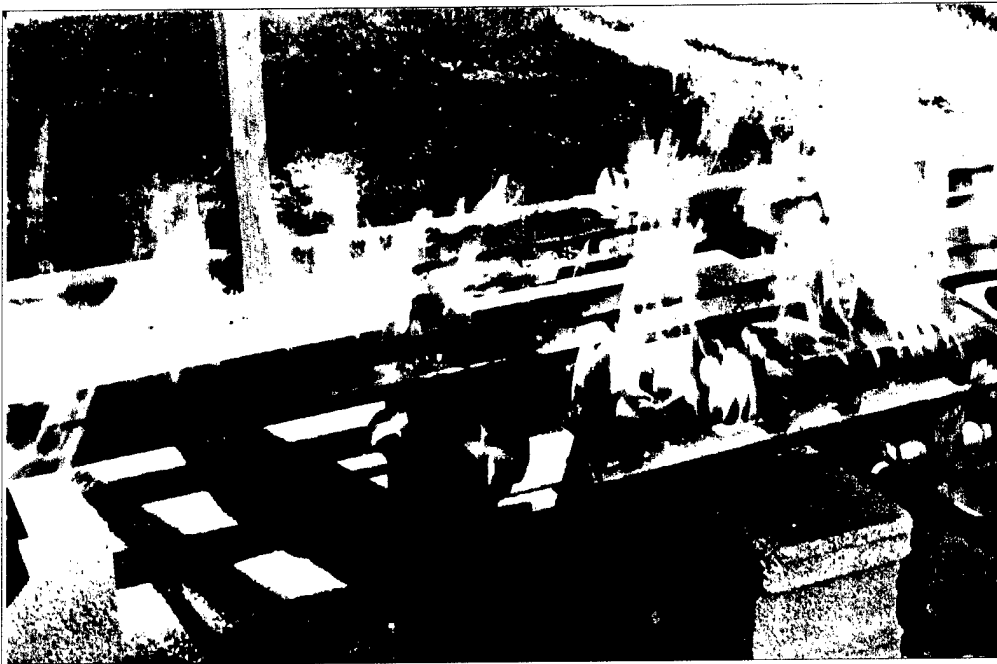

Figure 4-18. 50-50 air-propane fire at 40 SCFM, 1/30-second exposure.

## 4.2 REFLASH/RE-IGNITION

If the trainees do not apply an extinguishing agent long enough to extinguish the flame, the computer will simulate a re-ignition by reopening the propane (fuel) valve. As a result, the bilge fire will be re-ignited. This is a part of the training scenario to reproduce the problem that can occur in real fires if the small areas of flame, or hot ignition surfaces, are not properly taken care of while fighting the fire. The phenomenon is termed "reflash."

During the actual firefight training, the steel structure in and around the burner and the steel grating above the fire are heated up to a high temperature. When these hot steel surfaces contact with the extinguishing agent, hot steam is created. The restored propane flow may not re-ignite immediately with the presence of hot steam. The flame may not be able to propagate from the igniter to the burner. It has been found that providing a blower to blow the steam away minimizes or prevents this problem. It is necessary to assess this re-ignition problem with the air-propane mixture.

A series of tests were performed to observe the re-ignition problem with and without air admixture. For this purpose, a heavy steel grating, matching that used in the trainers, was installed above the bilge burner, as shown in Figure 4-19. Tests were run with the grating heated by the burner, to about 550° F as measured with an optical pyrometer, with steam formed by water from a fire hose hitting the hot steel. A fog nozzle was used on the fire hose, as is used in the trainers.

In the first of these tests, the flow rate of air and propane to the pilot box was low, and the steam extinguished the pilot. In subsequent tests the flow rate increased to 50 SCFM, both with 100 percent propane and 50-50 air-propane flows to the pilot were used. The results demonstrated that there were no subsequent ignition failures for both fuels. No delays or other differences in re-ignition could be detected.

The tests results concluded that using a 50-50 mix of air and propane will not affect reflash in the trainers.



Figure 4-19. Grating assembled over burner.

## CHAPTER 5.0

### 5.0 POLLUTANT MEASUREMENTS

#### 5.1 OVERVIEW ON GENERATION OF POLLUTANTS

The full size bilge burner using 100 percent propane and 50-50 air-propane fuels was tested to measure the air pollutants. The results of the tests indicated that it created about a total of 0.01-pound of methane, ethane, and acetylene per pound of propane if 100 percent propane is used. With a 50-50 air-propane mixture, about the same amount of pollutants are formed per pound of propane, as seen in Table 5-1. But the pollutants are reduced by a factor of 2 because less propane is used.

Table 5-1. Emission of Air Pollutants With 100 Percent Propane Fuel  
and 50-50 Air-Propane Mixture

Emissions*	Fuels					
	100 % Propane			50-50 Air -Propane		
	Test 1	Test 2	Avg.	Test 3	Test 4	Avg.
Methane	0.0032	0.0011	-	0.0018	0.0018	-
Ethylene	0.0005	0.00053	-	0.0005	0.0007	-
Acetylene	0.0071	0.0024	-	0.0044	0.0040	-
Ethane	-	-	-	-	-	-
Propene	-	-	-	-	-	-
Propane	-	0.0014	-	-	-	-
Propyne	0.0001	-	-	-	-	-
Butane	-	-	-	-	-	-
<b>TOTAL</b>	<b>0.0106</b>	<b>0.0054</b>	<b>~0.008</b>	<b>0.0067</b>	<b>0.0065</b>	<b>~0.0066</b>

Note: \* Weight of pollutant per unit weight of propane burned.

Roby, Scheffey, and Hamer (1996a) reported that air addition to 100 percent propane in the experiment laboratory burners, resembled those in the FFTFs. These burners had holes about the right size, but they were smaller than the real burners, and had no splash plates, that the full size burner had. Previous analyses of emissions from full-scale FFTFs found that the major unburned material was propane, equivalent to about 1 percent of the fuel, (Levine, 1991a, b, c). A number of minor constituents were noted (e.g., benzene, toluene, dimethyl benzene, etc.) but these ranged from 1/10 to 1/100 of the 1 percent (of the fuel burned) of the unburned propane. These species were observed by collecting them in traps such as tubes filled with adsorbent, then passing the adsorbent through a GC-MS. The adsorbent would not have adsorbed low molecular weight material, and the GC-MS used would not have responded to these species if they had been collected.

## 5.2 APPARATUS:

When the burner was first received it was coated with soot (see Figure 5-1). With the 50-50 air-propane mixture as fuel, the soot burned off and the measurements of exhaust CO simultaneously decreased to near zero.

Heavy steel gratings were placed above the burner. Figures 5-2 and 5-3 show the appearance of the flame as it issues from the grating and the gas sampling apparatus. A water-cooled sampling line is used for the gas sample that enters the plastic bags. A second line, not water cooled, is mounted as close as feasible to the water-cooled line. This line was used to measure CO<sub>2</sub>, which is proportional to the propane burned in the fire (as corrected for the other unburned species). An instrument gas pump is used to suck the gas sample through the water-cooled line and pressurize the sample bag. The CO<sub>2</sub> instrument has its own pump.

## 5.3 EXHAUST GAS SAMPLING

The exhaust gas was sampled at a stand-off distance of approximately 6 inches above the tips of the luminous flames (Figures 5-2 and 5-3). This was done to allow any exhaust and unburned fuel to burn to completion. The drawback of this distance is that the plume may mix with a varying amount of external air. Wind also has a major effect on the concentration of exhaust gases in the plume, but even when the wind was light (which was when data were taken) the CO<sub>2</sub> concentration varied from 0.2 percent to over 1 percent during the time the bag was filling. This shows that the plumes above the burner were highly striated, and even light winds moved the striations.

A series of tests were conducted with a large pan suspended above the burner. This pan was intended to mix and integrate the striations of the flow, and the sample tube assembly was inserted through a hole in the side of the pan. This assembly is shown in Figure 5-4.

The chemical analyses of the bag air samples were tested as shown in Table A-1 of Appendix A. Two bags were filled with 100 percent propane (Tests 1 and 2), and two bags were filled with the 50-50 air-propane fuel (Tests 3 and 4). In addition, a bag was filled while the burner was off (bag 5, as a blank).

The latter was subsequently analyzed to establish that the analysis method was valid for propane and that the low molecular weight species found in the exhaust did not come from the fuel.

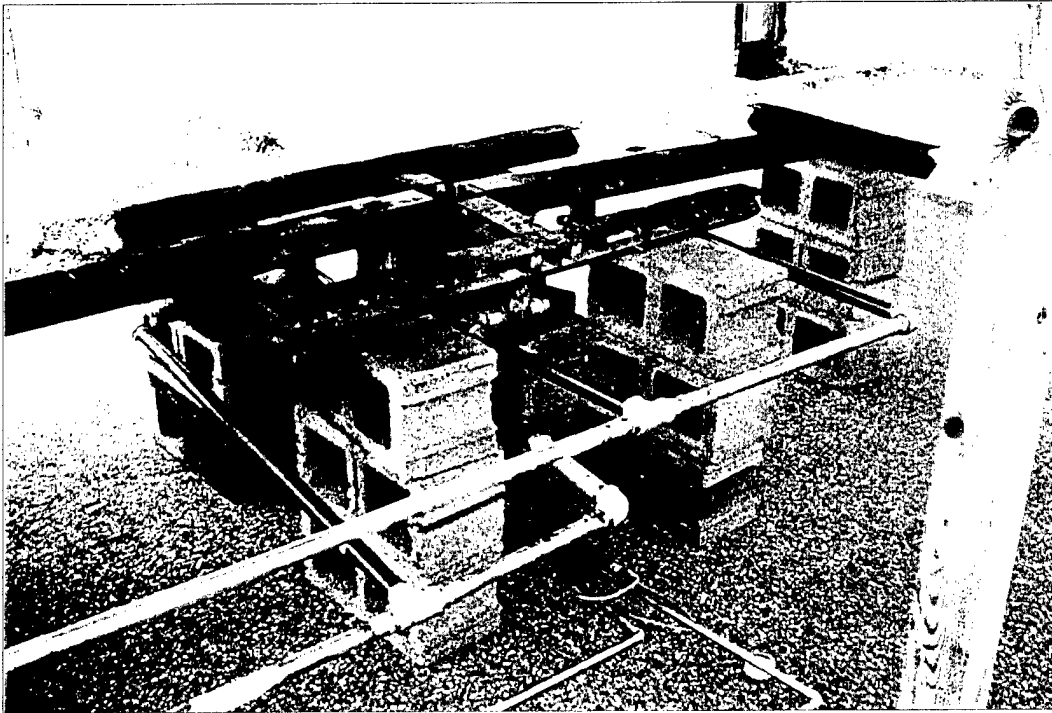

Figure 5-1. Burner assembly without grating.

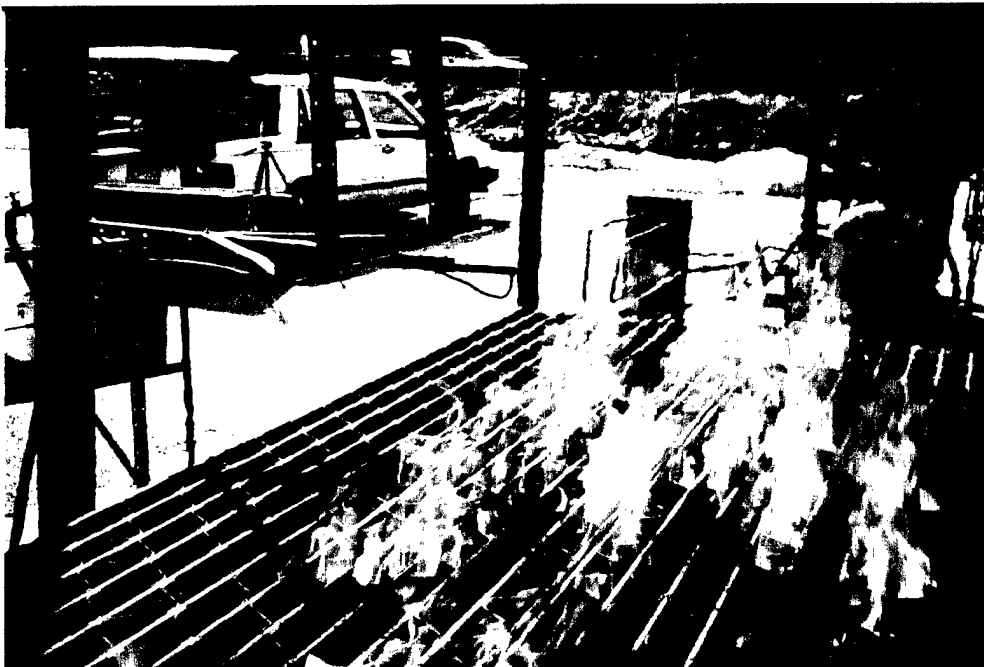

Figure 5-2. Flames issuing through grating.

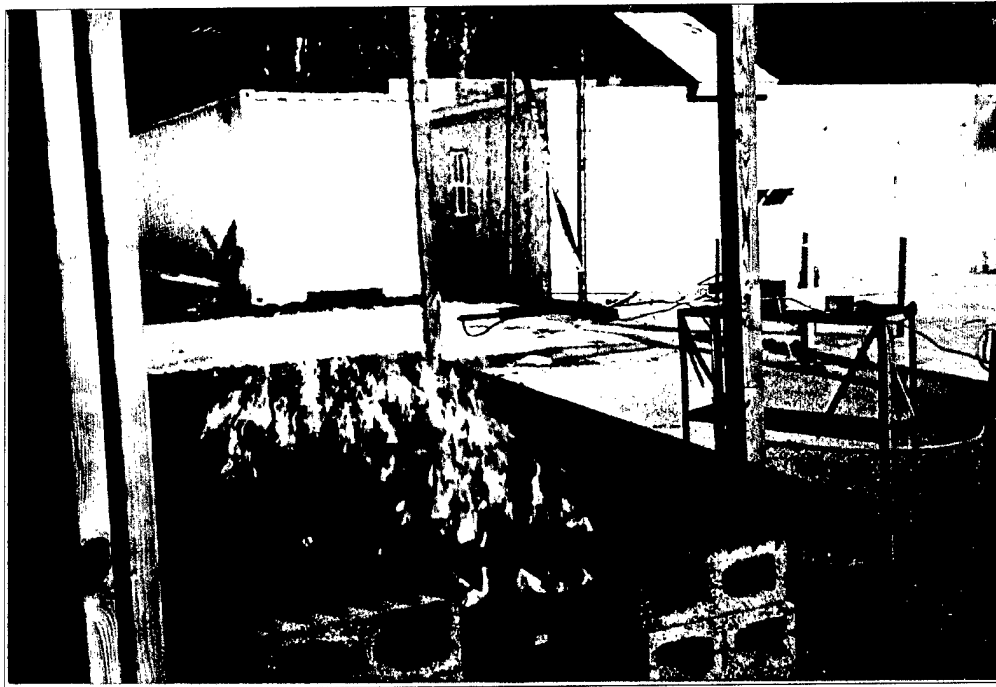

Figure 5-3. Flames issuing through grating, showing water-cooled probe.

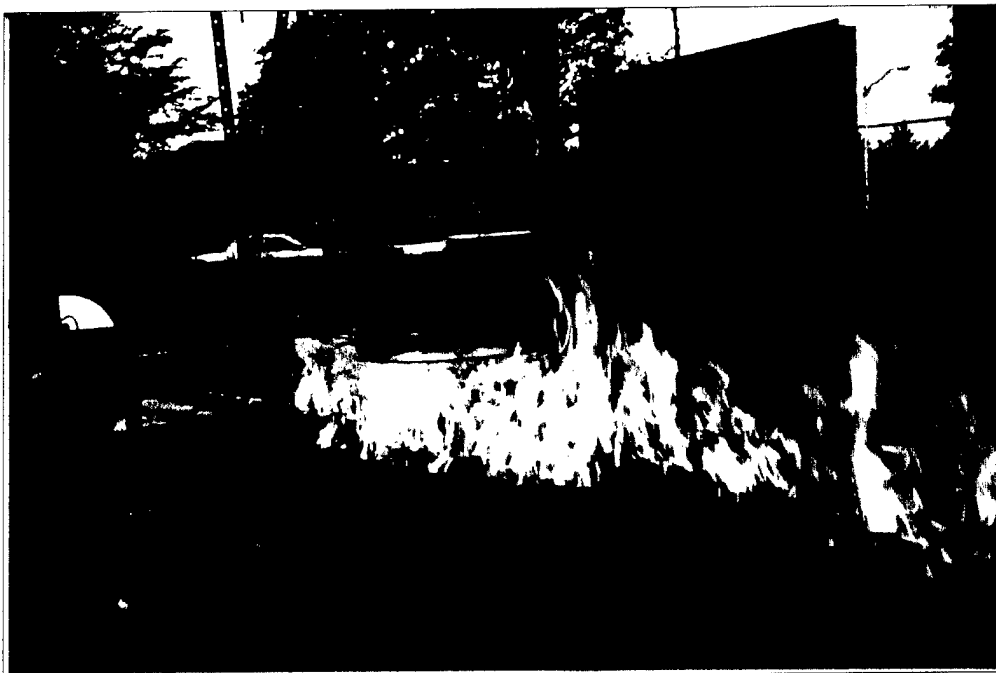

Figure 5-4. Collector pan with probes inserted inside.

## 5.4 DATA

The U. S. Army Center for Health Promotion and Preventative Medicine, Aberdeen Proving Ground, Maryland analyzed the bag samples. The test used a very sensitive gas chromatograph (GC) with a column sensitive to hydrocarbons from methane on up, and a flame ionization detector. The results of the analyses are shown in Appendix A.

Note that both the blank taken at MFRI and the laboratory blank (Table A-1) showed the absence of contamination. The air-propane mix had less than one part in a hundred of methane and the other light species. The concentration of propane in the fuel sample was actually closer to 500,000 part per million (ppm) than 250,000 ppm, but the analysis here is not precise because the sample was diluted multiple times, and even then the reading of the GC detector had to be estimated.

### 5.4.1 Calculations

The data were calculated on the basis of the weight of each species emitted in the exhaust per unit weight of propane fed to the burner. This number can be used, along with the amount of propane used per day (or year) in the trainer to calculate the amount of each pollutant formed. The results of a test with 100 percent propane (#1) are presented below as a sample calculation. The calculation method is presented in Appendix A.

The measured concentration of CO<sub>2</sub> is 4.35 mol percent, which is equivalent to 1.44 percent or 14,400 part per million (ppm) propane burned. Table 5-2 shows the calculations of the various species of air pollutants.

Table 5-2. Summary Results of Air Pollutants With 100 percent Propane  
(Test #1)

Gas	Analysis ppm	Mol. Fraction	Mol. Weight	Wt. of Species	Weight/ Wt. Propane*
Methane	128	0.009	16	0.142	0.0032
Ethylene	34	0.0236	28	0.019	0.00055
Acetylene	174	0.121	26	0.314	0.0071
Ethane	<1.7	-	30	-	-
Propylene	<1.7	-	42	-	-
Propane	<1.7	-	44	-	-
Propyne	2	0.00014	40	0.0055	0.00013
Butane	<1.7	-	58	-	-

\*The last column of Table 5-2 was previously posted as TEST 1 in Table 5-1.

## 5.5 CONCLUSIONS ON AIR POLLUTANT EMISSIONS

As indicated in Table 5-1, the mixture of 50-50 air-propane fuel reduces the total amount of the air pollutants by a factor of about 2 since only half the amount of propane was used. The major pollutants are acetylene, ethane, and ethylene. Based on the tests results, it can be concluded that the appearance of the flame with or without air is almost no different.

## CHAPTER 6.0

### 6.0 ECONOMIC FEASIBILITY - ESTIMATED COST/ BENEFIT ANALYSIS

To convert FFTFs that use 100 percent propane to those that use 50-50 air-propane fuel, some modifications of the current feed system from the propane tank to the trainer are required. These modifications involve the procurement of the liquid propane pump, air-propane proportioning device, and reconstruction of the fuel lines. Test and inspection of the new proportioning device requires time and additional cost. The trade-off between the fuel savings and modification costs are presented in this section.

#### 6.1 TOTAL ANNUAL PROPANE CONSUMPTION

As a part of this User Data Package, a survey of the total annual propane consumption within the U.S. Navy FFTFs was conducted. The results of the survey indicated that about 343,000 gallons of propane were used during year 1999 as shown in Table 6-1.

#### 6.2 ANNUAL FUEL COSTS

The unit price of propane varies with locality, weather, seasons, time of purchase, and global supply and demand. For the field experimental tests during the 1999 to 2000 period, the unit cost of propane the contractor paid was:

- \$0.70 per gallon during summer
- \$1.00 per gallon during winter
- \$0.80 per gallon annual average unit price

The average unit price is derived on a basis that the price was increased during 4 months of cold weather as:

$$(\$1.0 \times 4 \text{ months} + \$0.7 \times 8 \text{ months}) / 12 \text{ months} = \$0.80.$$

If a mixture of 50-50 air propane is used, the total savings in fuel purchase price is approximated as:

$$\$0.80 \times (343,000 \text{ gallon}/2) = \$137,200$$

Table 6-1. Annual Propane Consumption of FTFs

Site	Annual Propane Consumption of FTFs (In Gallons)				
	Surface Trainers	Actual Use	Submarine Trainers	Actual Use	Site Subtotal
New London CT			21C12	12,500	12,500
Bangor ME			21C12A	7,500	7,500
Pearl Harbor HI			21C12A	5,500	5,500
Kings Bay GA			21C12A	14,000	14,000
San Diego CA	19F1B, 19F3B, 19F4A	95,000	21C12	6,000	101,000
Norfolk VA	19F1B, 19F3B, 19F4A	111,000	21C12A	7,500	118,500
Mayport FL	19F1A, 19F4A	55,000			55,000
Newport RI	19F3A	9,000			9,000
Great Lakes, IL	19F5, 19F3C	15,000			15,000
Ingleside, TX	19F3C	5,000			5,000
	Subtotal	290,000	Subtotal	53,000	343,000

### 6.3 MODIFICATION COSTS

The additional cost to incorporate the air-propane proportioning device system is shown in Table 6-2:

Table 6-2.

Items	Est. Cost
Hardware procurement: Propane pump and propane/air proportioning device (off-of-the-shelf items)	\$20,000
Installation labor including a concrete pad	\$2,000
Test, certification and permit	\$2,000
Subtotal of initial modification cost	\$24,000

The total modification cost for all 18 FFTFs is:

$$\$ 24,000 \times 18 = \$ 432,000$$

If the service life of the propane pump and air-propane proportioning device is assumed to be 10 years, then the depreciation cost is \$2,000 per FFTFs per year.

The annual savings for the 18 FFTFs is:

$$\$137,200 - (\$2,000 \times 18) = \$101,200.$$

#### **6.4 PAYBACK ASSESMENT**

The total payback of the modifications is estimated:

$$\$432,000 / \$101,200 = 4.23 \text{ years, or about 4 years and 3 months.}$$

In other words, the additional costs induced from the modifications can be paid off in 4.26 years. After that the savings in fuel procurement are \$101,200 annually.

If the life cycle is assumed to be 10 years the total savings with the 50-50 air-propane proportioning device is:

$$\$101,200 * 5.77 \text{ yrs} = \$ 582,000.$$

## CHAPTER 7.0

### 7.0 OPERATION AND MAINTENANCE

Operation and Maintenance of the equipment is described in the following Sam Dick Industries reports:

(1) Operation and Maintenance Manual, XPV Packaged Vaporizing/Mixing System Models: XPV 2.5 through XPV 28.0, dated 04 December 1996 (P/N 52568)

(2) Operation and Maintenance Manual, STABILAIRES Liquid LPG Pump Packages Model: BS1 through BS3, dated 14 September 1996 (P/N 62631)

These reports were included with the equipment when it was purchased and is attached as Appendix C. Part of the text in this section is copied from those reports<sup>1</sup>.

“The XPV packaged vaporizing/mixing system is designed for long term trouble free operation. Due to the nature of its use, and the heavy duty it receives, it is important to provide scheduled maintenance.” A maintenance schedule and recommended spare parts list are shown in Appendix C.

#### 7.1 ADJUSTMENT PROCEDURES FOR SYSTEM OPERATING AND SAFETY CONTROLS

“All of the controls (except for the venturi regulator) are preset at the factory. However, vibration in transportation may alter the settings or it may be desirable to change the system delivery pressure (within the range of the installed venturi). Thus the control settings may need to be checked or readjusted. Any replaced controls will also require adjustment.”

“Most of these operations require the control enclosure to be open while the circuits are tested. At all time make absolutely sure that no LPG vapor is present around the wiring.” In addition, “always have a fire extinguisher handy when operating with the control enclosure open.” “The electrical arcing that occurs when the various switches and relays within the enclosure operate is a possible source of explosive ignition.” For these reasons, do not attempt to adjust the pressure switches with the power on.

##### 7.1.1 Motive Pressure (set pressure of the venturi regulator)

“The motive pressure for the venturi is stamped on the base of the venturi housing. This pressure is adjusted using the vapor pressure regulator on the LPG (propane) vapor train. The adjustment should be made with the system in operation.” The manual suggests using a Btu meter for accurate adjustment, but the actual amount of air mixed with propane is not critical for fire fighter trainers. Using the supplied venturi, the air-propane mixture will be about 50-50 percent by volume.

---

<sup>1</sup>Reprinted with permission from Algas-SDI International, LLC

The XPV operation manual states that for a delivery pressure (accumulator tank pressure) of 12 psig, the inlet vapor pressure should be 140 psig, leading to a nozzle motive pressure of 110 to 130 psig. Experimental tests show that an inlet vapor pressure of 123 psig is barely adequate. Navy FFTFs seem to be operational at an inlet pressure (downstream of the block and vent) of 14 psig, so a delivery pressure somewhat above 123 psig may be needed.

## **7.1.2 System Delivery Pressure<sup>2</sup>**

**7.1.2.1 Pressure Control Switch (1).** “The system delivery pressure (within the range of the installed venturi) is set by means of the tank pressure adjustment screw (item 22). The on/off differential pressure is set by means of item 22. See Appendix C for additional adjustment information.

To adjust the switch, use a 1/4” open-end wrench, turn the main adjustment screw counterclockwise to lower the setpoint or clockwise to raise the setpoint. Turn the adjusting screw until the “ON” setpoint is reached, then set the differential adjustment for a deadband (off) of 0.75 to 1 psi. A typical setting is between E and F.”

**7.1.2.2 High Tank Pressure Switch (3).** “The pressure switch (3) is located in the control box (13). To set, turn adjusting wheel to approximate setting shown on the indicator scale on the switch.” For a delivery pressure of 12 psig, set the high tank pressure switch for 15 psig.” If the switch has a higher setting, set it to 17 psig for a delivery pressure of 14 psig.

**7.1.2.3 Low Vapor Pressure Switch (5).** Slowly throttle the vaporizer propane vapor outlet valve (12), while the system is operating. This lowers the propane vapor pressure being sent to the mixer. Observe the propane inlet vapor pressure gauge (4) and note the pressure at which the low vapor pressure switch (5) opens and disables the venturi solenoid valve. “To set the low vapor pressure switch, turn the adjusting wheel to the approximate setting shown on the indicator scale on the switch body. Repeat the process to verify the setpoint. Note the low vapor pressure switch only disables the venturi solenoid valve, and does not shut off the XPV.”

**7.1.2.4 Further maintenance and troubleshooting information.** Appendix C of this User Data Package presents the manufacturer’s detailed information on subjects such as testing and replacing the venturi check valve and a detailed troubleshooting guide.

## **7.2 OPERATION AND MAINTENANCE OF THE LIQUID PROPANE PUMP**

### **7.2.1 Initial Startup**

**7.2.1.1 Operation Check.** Thoroughly check the entire facility for safe operation and function before starting up the process. The check must include the condition and operation of the storage tanks, pipes, electrical wiring, and appropriate valves all the way to the outlet (inlet pipes to the trainer). Prohibit all smoking throughout the entire facility until a complete inspection is conducted to ensure that there are no propane leaks. Even smoking outdoors close by is dangerous.

---

<sup>2</sup> Refer to Table 2-2 and Figure 2-4 for item numbers listed in this subsection

### 7.2.1.2 Verify that the Pump System has Been Installed Correctly:

1. Check the pump system for correct installation of all components. All bolts should be tightened and fittings secured.
2. Check the wiring, make sure that there are no broken or frayed wires and that all wiring is properly installed. Check all electrical conduits for correct installation and ensure that all fittings are tightened.
3. Measure the incoming voltage with a voltmeter to check if it is the correct voltage for the system.
4. "All piping should be clean, free of moisture and have not leaks. Even a small leak anywhere in the entire facility is unacceptable."

**7.2.1.3 Pump Setting and Adjustment Procedures.** "Perform these procedures on initial startup of the system, if the pump is restarted after being idle, or if the delivery pressure or tank pressure changes."

#### 7.2.1.3.1 Adjusting Output Setpoint:

1. "Determine the required pump discharge pressure."
2. "Slowly open the shut-off valves in the storage tank for pump suction line and return lines. Open all shut-off valves between the storage tank and the pump."
3. Verify tank pressure reading and the gauge reading on the propane pump inlet. They should correspond with each other. If not, refer to step #2 above.
4. "Close shut-off valve at pump outlet."
5. "Loosen locknut on adjustment bolt for the control valve, item #4. Turn adjustment bolt out until it is loose." **DO NOT** remove it completely.
6. Turn pump on. You may notice a slight pressure increase at the outlet pressure gauge.
7. "Slowly start to turn the adjustment bolt "in", on the control relief valve, item #4, until the desired outlet pressure is attained. Stop the adjustment when the pressure is obtained."

8. "Tighten locknut, making sure adjustment bolt does not turn while tightening"

### 7.2.1.3.2 Internal Pump Relief Valve Adjustment<sup>3</sup>

**Caution: Try this test only briefly. "If the relief valve doesn't open during the test, open the outlet valve. The internal bypass valve of the pump is designed for emergency protection only. It may be damaged if this procedure is done for any length of time."**

1. "To test internal pump bypass valve (item #2) for proper operation, with pump outlet closed and pump on, momentarily close manual shut-off valve in the control relief valve return line to the tank. The differential pressure increase should be between 150 psi and 170 psi over the inlet pressure (the factory setting of the internal bypass valve of the pump.)"

"For example: if the inlet pressure is 40 psig, the outlet pressure should be between 190 and 210 psig."

Differential pressure is the difference between pump inlet and outlet pressure, or the amount of pressure the pump adds to the propane coming into it

1. "The internal bypass valve is factory set. Under normal operation the valve should not need to be adjusted. However, if the valve opens above 170 psig or below 120 psig differential pressure, then it should be adjusted."
2. "Open manual shut-off valve in the control relief valve return line to the tank."
3. "Open pump outlet shut-off valve (item #7). Pump is now ready for operation."

## 7.2.2 Operation

### A. Start-up

1. "Check the system thoroughly before putting it into operation. Any problem with the system: leak, faulty valve, loose bolt or connection is unacceptable. Repairs must be made immediately."
2. "The wiring should be examined for correct connections, voltage and proper rotation."
3. "Open all valves in the lines to the pump."

---

<sup>3</sup> Refer to Table 2-3 and Figure 2-7 for item numbers listed in this subsection

4. "Turn on the power to the pump."

5. "Turn on the pump."

"If it is in correct operating order, the motor should start quickly, the pressure will come up immediately, and the pump will run at normal operating speed and the pressure gauge on the discharge side of the pump will indicate the correct operating pressure." If the pump turns in the wrong direction, shut it off and shift (transpose) two of the three electrical wires feeding the pump. Then turn it on again. Refer to the troubleshooting guides in Appendix C if there is pump noise, vibration, leakage, overheating, or low pressure.

B. Normal Operation:

1. Operating Precautions

- "Do not run the pump dry. This will damage the pump."
- "Do not allow propane liquid to cavitate in the pump as this will also damage it."
- "Correct piping minimizes vaporization of the propane liquid into the pump. Excessive vaporization in the inlet line causes pump noise and excessive wear. Restrictive intake piping, globe valves, or some types of tank outlet valves can cause cavitation. Circulation of propane liquid through the built-in relief valve causes cavitation inside the pump. The relief valve is an emergency protection device only."
- "Check the inlet and outlet pressure at regular intervals."
- "Check the bearing seal at the side of the pump for leaks."
- "Pump drives should operate satisfactorily with a minimum of vibration."
- "If direct coupled pumps vibrate excessively they should be checked for alignment as noted in the maintenance section."

2. Inlet Pressure

If the inlet pressure differs or fluctuates from the setpoint, the system should be shut down. Fuel lines should be bled to zero gauge pressure and purged, and the sources of problems identified and corrected. (Changes in climate and different batches of propane will also cause changes in inlet pressure)

### 3. Outlet Pressure

If the outlet pressure and all other parts of the pump system are functioning normally but the outlet pressure is incorrect, the control valve must be reset. See “Adjusting the Output Setpoint” procedure in the initial startup section.”

#### **7.2.3 Maintenance Procedures**

Maintenance procedures, including cleaning the inlet strainer, lubrication of the pump bearings, and detailed instructions for replacement of pump vanes and other parts are described in the manufacturer’s manual in Appendix C of this User Data Package.

## CHAPTER 8.0

### 8.0 PROPANE MATERIAL SAFETY DATA SHEET (MSDS)

The Material Safety Data Sheet containing the required information about the propane used in the air-propane mixture used as in the FFTFs is presented in Appendix D. This information includes:

- Chemical product and company identification
- Composition information on ingredients
- Hazardous identification
- First aid measures
- Fire fighting measures
- Accidental release measures
- Handling and storage
- Exposure controls
- Personal protection
- Physical and chemical properties
- Stability and reactivity
- Toxicology information
- Disposal considerations
- Transport information
- Regulatory information

## CHAPTER 9.0

### 9.0 CONCLUSIONS AND RECOMMENDATIONS

#### 9.1 CONCLUSIONS

- The use of the equipment described in this User Data Package will greatly reduce the already low air emissions from Navy FFTFs, and save about half the cost of the propane used. If all 18 Navy FFTFs are retrofitted, the cost to the Navy will be about \$582,000, and propane savings per year will be about \$100,000 at current FFTF utilization rates.
- The already low emissions of air pollutants by the FFTFs will be reduced by a factor of 2, primarily because less propane is used. The air admixture to the propane will reduce or eliminate the buildup of carbon (soot) on the burners, and in tests to date, the elimination of this carbon leads to a carbon monoxide emission of substantially zero.
- To maintain the same compartment temperatures in the FFTFs with half the flow of propane, the ventilation airflow through the FFTFs will have to be reduced by a factor of 2. Existing FFTFs are equipped with controllable speed fans and adjustable dampers to permit easy adjustment to the ventilation airflow. Reducing the ventilation airflow will have no effect on the safety of the trainees because they wear breathing equipment. Even if they lost their breathing protection, the fresh air flowing up through the floor grates would provide enough air to ensure their safety.
- Reducing the ventilation airflow has another advantage. With less air to dilute the artificial smoke introduced into the training compartment, the smoke will be denser, hence more realistic for training. Alternatively, less smoke agent can be used, further reducing the emissions of air pollutants from the FFTFs.
- Exhaustive tests described in this User Data Package establish that with a 50-50 mix of air and propane by volume there will not be detectable changes in the appearance or size of the flames or operational changes in the FFTFs.
- The equipment is carefully engineered and manufactured to maintain safety under all conditions. It needs no protection from the weather, operates automatically, and requires little maintenance.

#### 9.2 RECOMMENDATIONS

- It is recommended that Navy commands of FFTFs consider the use of this equipment, particularly if there is a need to meet tightened local environmental restrictions.

- A full-scale demonstration should be conducted at one of the existing fire fighting training facilities. This demonstration should be properly conducted to ensure no disruption of the training activity.
- Integration of the automatic 50-50 air-propane proportioning device to the existing computer-controlled console in the FFTFs should be made prior to a full-scale demonstration.

## CHAPTER 10.0

### 10.0 ACKNOWLEDGEMENTS

The authors wish to thank Mr. Stephen S. Carter and his staff for providing facilities and supporting tests of the equipment at the Maryland Fire and Rescue Institute University of Maryland, and Mr. Harry Tyler of Automated Energy Systems, Royal Oak, Md., for assistance with respect to defining the equipment purchased.

## CHAPTER 11.0

### 11.0 REFERENCES

Chief of Naval Operations (1995): Surface Ship Survivability Training Requirements, OPNAV Instruction 3541.1E, Washington, D.C., March 1995.

Lee, T. R. (1993). Initiation Decision Report (IRD) on Environmentally Benign Firefighting Training Facilities (FFTF), Naval Civil Engineering Laboratory, Technical Memorandum TM-74-93-02, Port Hueneme, CA, 1993.

Levine, R. S. (1991a). Partial Results of Gas Analysis II, Memo to Naval Training Systems Center, July 1991.

\_\_\_\_\_ (1991b). Results of Gas Analysis, Prototype Fireplaces at AAI Corp, Memo to Naval Training Systems Center, Oct 1991.

\_\_\_\_\_ (1991c). Results of Gas Analysis II, Prototype Fireplaces at AAI Corp, Analysis of Minor Constituents, Memo to Naval Training Systems Center, Nov 1991.

National Fire Code. (1998). No. 58, Liquefied Petroleum Gases, vol 3., National Fire Protection Association, Quincy MA, 1998.

National Fire Code. (1999). No. 70, National Electrical Code, vol 3., National Fire Protection Association, Quincy, MA, 1999.

Naval Facilities Engineering Command, Atlantic Division (1987). Firefighting Schools Facilities Criteria 21C12 and 19F Series Devices. March 1987

Roby, R. J., Scheffey, J. L., and Hamer, A. J. (1996a). Environmentally Friendly Fire Fighter Training Facilities, Hugh Associates, Incl, 6180/0515A.1:FWW, Aug 1996.

Roby, R. J., Scheffey, J. L., Hamer, A. J., Lee, T. R., Leonard, J., Williams, F., and Clark, K. (1996). Air Emission Reduction for Advanced FireFighter Training Facilities (FFTF), Naval Facilities Engineering Service Center, Technical Memorandum TM-2213-ENV. Port Hueneme, CA Sept 1996.

Thomas Register. (1998). List of manufacturers, Vol 9, pp 16162-16174

**APPENDIX A**  
**CHEMICAL ANALYSIS RESULTS**  
**FROM**  
**THE ARMY CENTER FOR HEALTH**  
**PROMOTION AND PREVENTIATIVE MEDICINE**

Table A-1. Analysis of Exhaust Gas From Bagged Samples  
 By Army Center for Health Promotion and Preventative Medicine  
 Edgewood, MD. Analysis of 25 May 2000

Compound	LAB BLANK (PPM)	1 (PPM)	2 (PPM)	3 (PPM)	4 (PPM)	5 (PPM)
Methane	<1.7	128	28	58	560	1.9
Ethylene	<1.7	34	8	8.8	127	<1.7
Acetylene	<1.7	174	38	87	770	<1.7
Ethane	<1.7	<1.7	<1.7	<1.7	3.6	<1.7
Propylene	<1.7	<1.7	<1.7	<1.7	<1.7	<1.7
Propane	<1.7	<1.7	13	<1.7	<1.7	<1.7
Propyne	<1.7	2	<1.7	<1.7	<1.7	<1.7
Butane	<1.7	<1.7	<1.7	<1.7	<1.7	<1.7
Pentane	<1.7	<1.7	<1.7	<1.7	<1.7	<1.7
Hexane	<1.7	<1.7	<1.7	<1.7	<1.7	<1.7
CO <sub>2</sub>	N/A	43,500	29,500	34,500	34,500	300

N/A Not Analyzed

Note: Samples were diluted 30 fold with helium prior to CO<sub>2</sub> analysis. CO<sub>2</sub> values are  $\pm$  500 PPM

The first step is to calculate the amount of propane that was burned to furnish the gases in the sample. Virtually all the propane burned formed CO<sub>2</sub>, measured here as 43,500 parts per-million (ppm). But three CO<sub>2</sub> molecules are formed for each molecule of propane. To be consistent, the amounts of gas will be expressed in terms of ppm of gas in the bag. The propane burned, if it had not been burned but has been collected in the bag, is 43500/3 or 14,500ppm.

Methane was measured as 128 ppm. The mole fraction of methane formed per mole of propane is then, 128/14,500 = 0.009. The molecular weight of methane is 16. So the weight of methane formed per gram mole of propane burned is (0.009 x 16) = 0.142 grams. Since 1 mole of propane weighs 44 grams, the amount of methane formed [er unit weight of propane is 0.142/44 = 0.004 grams/gram or pounds/pounds of propane burned.

**APPENDIX B**

**SAFETY AND AUTOMATIC OPERATIONAL FEATURES  
OF THE VAPORIZER/MIXER AND  
“STABILAIRES” LIQUID LPG PUMP PACKAGE**

## VAPORIZER/MIXER

The unit has a solid state control system in the control box that controls all operation and continuously monitors the safety of the system.

The control box is explosion proof, Class 1, Division 1, Group D, as defined in National Fire Protection Association (NFPA) Standards 58 and 70. All electrical components that can cause ignition are located in the control box. While it is possible that accidental leaks in the propane piping can mix with air and create combustible or explosive mixtures, there are no ignition sources in the equipment that can be contacted by the adventitious gas cloud.

A venturi system is used to mix air into the vaporized petroleum gas stream in the equipment. This limits the amount of air entrained by the mechanical design of the venturi, and of course, no air at all is entrained unless the vaporized fuel is flowing through the venturi at the design pressure, which causes the pressure at the venturi throat to fall below atmospheric pressure. There is no danger that this air/fuel mix will burn or explode, since approximately 1/5 the amount of air needed to reach a combustible limit can be entrained. The air/fuel blend is too rich to burn.

The heated core of the vaporizer is maintained between 200 and 210°F by a dual unit solid state sensor and the control board. Each sensor unit can tell the control board to shut down the equipment if it senses an overtemperature. The fuel inlet solenoid valve will not open until the heater temperature is high enough to vaporize the liquid propane. If the liquid level in the vaporizer gets too high, a float operated level device will shut the inlet solenoid valve.

The accumulator tank pressure, at 14 or 16 psig, is too low for liquid propane to exist in that tank. This means that even if a sustained fire could exist outside the tank, a Boiling Liquid Expanding Vapor Explosion (BLEVE) can not occur. The BLEVE phenomenon has been known to occur with railroad tank cars in train accidents. When metal failure releases the pressure over hot liquid in the car, it boils rapidly, the vapor becomes ignited, and the burning gas cloud causes radiant heat that can kill fire fighters.

A safety relief valve on the accumulator prevents the pressure from exceeding the preset value (a little over 20 psig). A safety relief valve, set at approximately 150 psig, is also installed on the vaporizer.

The propane inlet solenoid valve also closes in case of accumulator overpressure.

The entire vaporizer/mixer unit will not suffer any damage if for some reason it is energized in "dry" (no liquid propane) conditions.

## **“STABILAIRES” LIQUID LPG PUMP PACKAGE**

The unit has an explosion proof motor, meeting the requirements of NFPA Class 1, Division 1, Group D. Therefore, it will not ignite a cloud of air-gas mixture that might exist in the vicinity due to an accidental propane leak.

The motor bearings do not require lubrication or maintenance of any kind.

It has a pressure relief valve that sets the output pressure by returning excess fluid to the storage tank. An additional relief valve internal to the pump recycles fluid if the return line and the delivery line are blocked (such as by the valves inadvertently being closed). A strainer installed in the inlet line prevents pump damage due to debris in the propane. A relief valve is also installed on the system outlet line in case valves are closed locking liquid propane in this line.

A bypass check valve is included so that the pump need not be operated in case the vapor pressure in the storage tank is high enough to operate the vaporizer/mixer.

**APPENDIX C**

**OPERATION AND MAINTENANCE MANUALS  
FOR SAM DICK INDUSTRIES**

**\*XPV PACKAGED VAPORIZING/MIXING SYSTEM  
MODELS XPV2.5 THROUGH XPV28.0**

**AND**

**\*STABILIAIRE LIQUID LPG PUMP PACKAGES  
MODELS: BS1 THROUGH BS3**

# XPV

**Packaged Vaporizing/Mixing System**  
**Models: XPV2.5 through XPV28.0**

## OPERATION & MAINTENANCE MANUAL

PO. Box 70498, 1140 N.W. 46th Street, Seattle, WA 98107, U.S.A.  
Tel.: 206-789-5410 Fax: 206-789-5414

## **WARNING**

- Read this OPERATION MANUAL before operating this equipment.
- **NOTE:** Sam Dick Industries, Inc. reserves the right to use alternate manufacturers' components as vendor delivery applicability dictates. Literature contained in the Operation Manual has been supplied by vendors. Please check to be sure supplied data matches your configuration. Contact Sam Dick Industries if any questions exist.
- This equipment uses LPG, a flammable fuel handled under pressure. Inherent hazards exist and a thorough understanding of the equipment is required to allow safe operation and maintenance.
- Allow only a TRAINED and FULLY QUALIFIED PERSON to service this equipment.
- Any time a components must be replaced, use the same type, model, etc. DO NOT SUBSTITUTE! The consequences from such actions are unpredictable and may lead to dire consequences. When components are replaced with components not approved for use in our FM/CSA listed equipment, the FM/CSA listing becomes void for that unit.

**WARRANTY REGISTRATION**

**Roger Duquette**  
**Customer Service Department**

Type of Equipment: \_\_\_\_\_ Serial Number: \_\_\_\_\_

SDI Sales Order #: \_\_\_\_\_ Order Date: \_\_\_\_\_

Purchased By: \_\_\_\_\_

\_\_\_\_\_

\_\_\_\_\_

To help us give you better service, please fill out this warranty registration form and return it to us so we can register your purchase and follow up on the performance of our equipment. We are dedicated to producing a quality product and if you have a problem, we want to know about it. Please help us with a small amount of information about your company and about how you are using the equipment. If you need to call us, please have the type of equipment and the serial number handy so we can give you accurate information. If you have had any kind of problem with this equipment up to now, or you have any comments, please attach a separate sheet to this form to tell me about it. Keep a copy of this for your records.

End Customer/Company Name: \_\_\_\_\_

Address: \_\_\_\_\_ Tel: \_\_\_\_\_

City: \_\_\_\_\_ State: \_\_\_\_\_ Zip: \_\_\_\_\_ Fax: \_\_\_\_\_

Name of individual to contact for follow up information: \_\_\_\_\_

Title: \_\_\_\_\_

Usage - Circle one:      Base Load      Standby System  
                                 Peak Shaving      Other: \_\_\_\_\_

In what industry is the equipment being used? \_\_\_\_\_ SIC Code: \_\_\_\_\_

When was the equipment put in service? \_\_\_\_ / \_\_\_\_ / \_\_\_\_

Note: If you have more than one piece of our equipment, fill out one warranty sheet and staple the others to it. We'll do the rest.

How can we better meet your needs?

\_\_\_\_\_  
\_\_\_\_\_  
\_\_\_\_\_

*Innovative Solutions to Energy Challenges*

---

-----  
-----  
-----  
-----

Place  
Postage  
Here

 **Sam Dick Industries**

*....a subsidiary of Eclipse, Inc.*

**Attn: Customer Service Department**  
**P.O. Box 70498**  
**Seattle WA 98107**

---

## NOTICE

*Sam Dick Industries, Inc. (SDI)* shall not be liable for technical and/or editorial errors in this manual nor omissions from this manual. **SDI** makes no warranties, express or implied, including the implied warranties of merchantability and fitness for a particular purpose with respect to this manual, and in no event shall **SDI** be liable for any special or consequential damages including, but not limited to, loss of production, loss of profits, etc.

Product names used herein are for manufacturer or supplier identification only and may be trademarks/registered trademarks of these companies.

Copyright © 1997  
by **Sam Dick Industries, Inc.**  
Seattle, WA 98107

All rights reserved. No part of this manual may be reproduced or copied in any form or by any means - graphic, electronic, or mechanical - without the prior express written consent from **Sam Dick Industries, Inc.**, Seattle, WA., USA

**Table 1** — Wire Length Chart (#4 AWG)

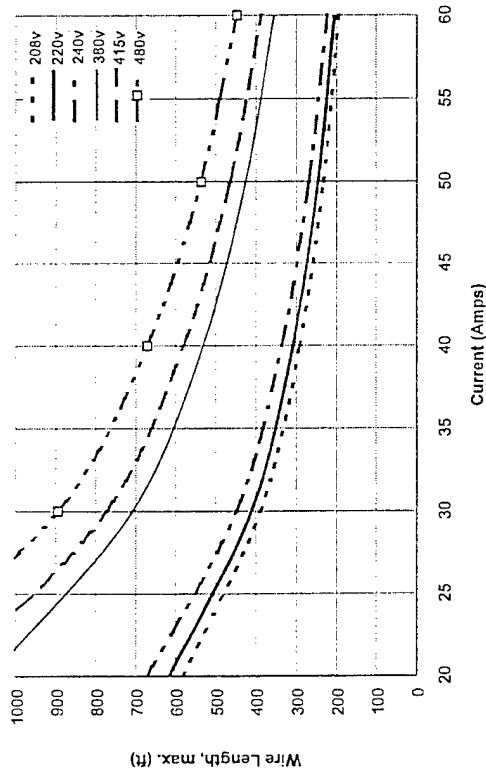

**Table 2** — Wire Length Chart (#6 AWG)

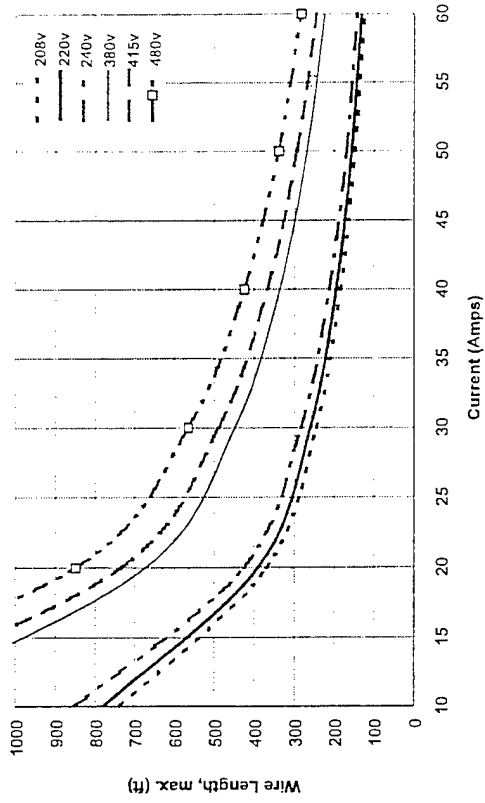

**Table 3** — Wire Length Chart (#8 AWG)

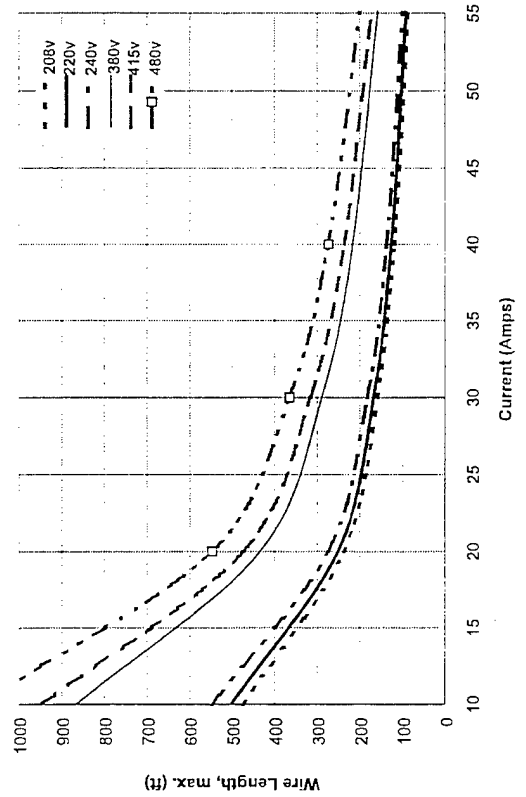

**Table 4** — Wire Length Chart (#10 AWG)

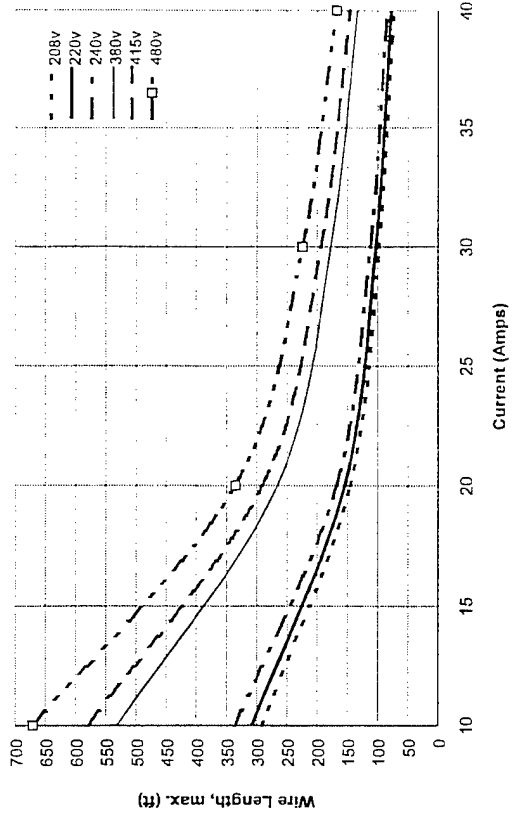

# TABLE OF CONTENTS

<u>DESCRIPTION</u>	<u>PAGE</u>
1. INTRODUCTION . . . . .	2
2. DESCRIPTION . . . . .	2
A. Liquid Line . . . . .	5
B. Liquid Pump . . . . .	5
C. Safety Relief Valve . . . . .	5
D. Electrical Service . . . . .	5
E. Major Components . . . . .	11
3. INSTALLATION . . . . .	10
4. OPERATING INSTRUCTIONS . . . . .	17
5. MAINTENANCE . . . . .	18
A. System Adjustment Procedures . . . . .	20
B. Venturi Check Valve Installation Instructions . . . . .	24
C. Leak Check Procedure - Venturi Check Valve . . . . .	26
D. BTU Gas/Air Mixture Adjustment Procedures . . . . .	27
6. TROUBLESHOOTING . . . . .	30

## APPENDIX

Parts Information . . . . .	A
Technical System Information . . . . .	B
Data Sheet	
Drawings	
Recommended Spare Parts	

## DRAWINGS

Typical Operation Drawing . . . . .	1
Liquid Line Reference Drawing . . . . .	4
Typical Installation Drawings . . . . .	8
Components Drawing . . . . .	11
Venturi Check Valve Assembly Drawing . . . . .	23

# TABLE OF CONTENTS

DESCRIPTION

PAGE

TABLES AND CHARTS

Liquid Line Sizing Chart . . . . .	6
Wire Sizing Chart . . . . .	7

**This page intentionally left blank.**

# TYPICAL OPERATION OF XPV VAPORIZER/MIXER SYSTEM

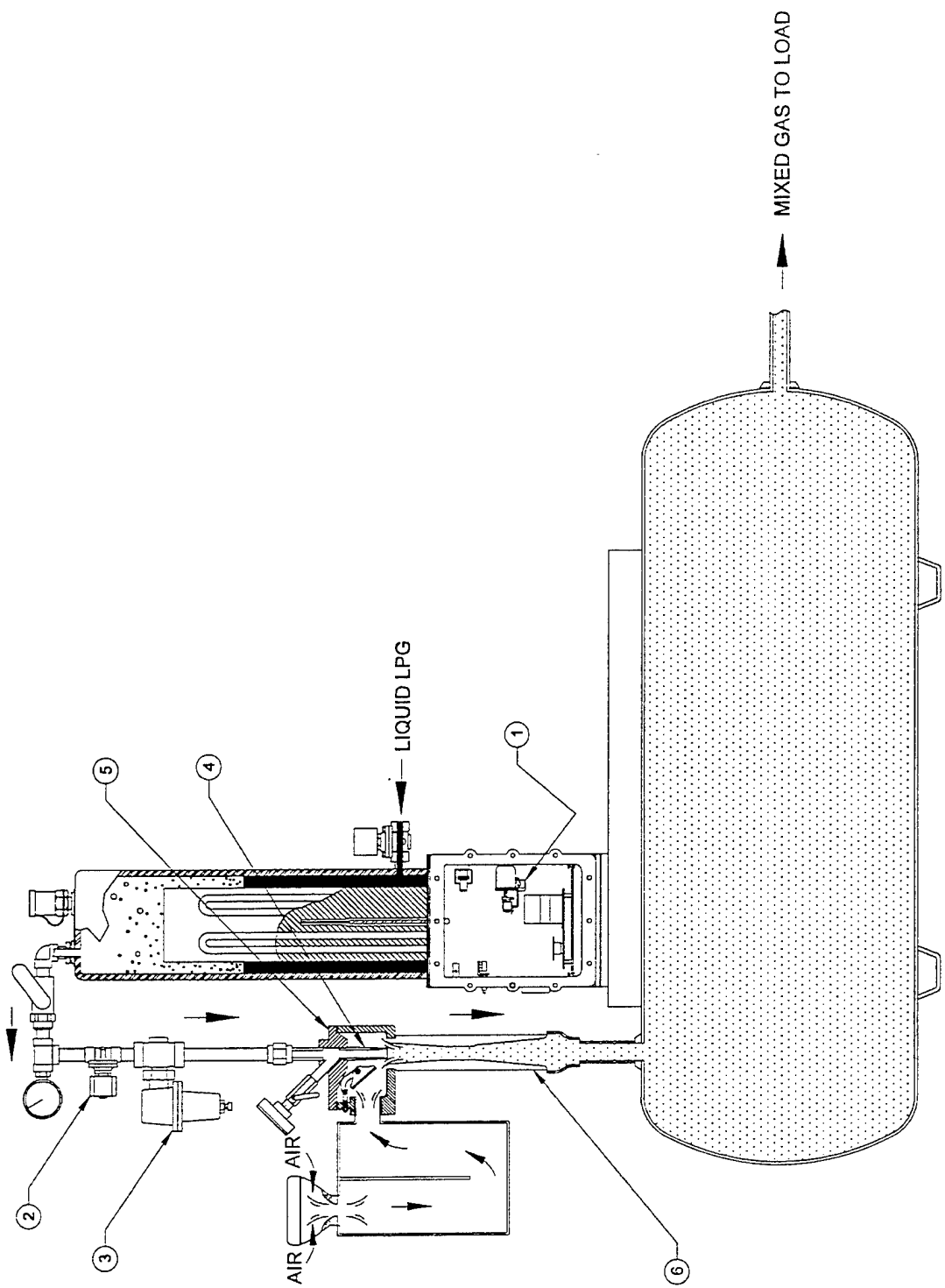

# XPV

**Packaged Vaporizing/Mixing System**  
**Models: XPV2.5 through XPV28.0**

## 1. INTRODUCTION

The XPV Liquefied Petroleum Gas (LPG) vaporizing/mixing systems from Sam Dick Industries are self-contained units providing a mixture of LPG gas and air which can replace natural gas. These explosion-proof systems are compact and made to very strict standards so they can be installed almost anywhere. Operation is quiet, reliable, safe and automatic. Solid state electronics make control of the mixing process simple and easy. An accumulator tank enables the venturi to cycle on and off to meet the required load demand.

## 2. DESCRIPTION

The XPV compact LPG vaporizer/mixer systems are available in various propane models providing a gas/air mix from 2.5 to 28 million BTU at pressures from 5 to 12 PSIG depending on the model selected. Other models are available for butane and butane/propane mixtures. The gas/air mix provided is compatible with natural gas and may be used as a direct replacement for it without adjustments to your burner systems.

This combination system uses our proven XP electric vaporizer to vaporize the LPG and the same atmospheric venturi system used on our reliable Vaporaire mixing machines. The gas is mixed and stored in the accumulator tank to provide uninterrupted flow of mixed gas from full flow to no flow, automatically.

All models are explosion-proof and meet the requirements of Class I, Division 1, Group D as defined by NFPA Pamphlets 58 and 70. That classification allows you to install them almost anywhere with minimum clearances for convenient installation.

Operation is automatic. To start the system, simply open the liquid inlet hand valve and press the "start" switch. A solid state control system controls all operations and continually monitors the safety of the system. When the system is on, mixed gas is available immediately. If the system is off, it takes less than one minute after the start switch is pressed to be ready to provide gas at full flow.

Power requirements vary depending on the size and model of the system. Please refer to the data sheet provided in Appendix B of this manual for the specific requirements for your system.

The combination of explosion-proof vaporizer and venturi, accumulator tank and solid state control make XPV systems completely safe and reliable regardless of where they are installed.

A liquid pump, such as the Sam Dick Industries Stabilaire pump system, may be required to provide sufficient gas pressure for the mixing process. The required pressure for your system is indicated on the data sheet in Appendix B of this manual. If your supply tank will not provide the required pressure under all expected conditions, a pump will be needed.

The drawings on pages 9 through 13 identify the components of the XPV system. The number references in the following description of operation refer to the drawing on page 9 for external components and on page 13 for control components.

**THE VAPORIZER:** The vaporizer is composed of multiple resistance heating elements imbedded in a finned aluminum heat exchanger core. An RTD temperature sensor (31) and a solid state control system (24) maintain the heater core temperature at 200 to 210° F. Liquid LPG enters the vaporizer through the inlet solenoid valve (27) and comes in contact with the heater core. The LPG extracts heat from the core and vaporizes. When the core cools to the set temperature the control system turns the heater contactor on heating the core as needed to maintain temperature. The control board also provides the logic to shut off the system if an unsafe condition exists.

**THE MIXER:** The pressure of the vaporized LPG from the vaporizer closes the low vapor switch (5) and activates the venturi control circuit after an initial time delay. The venturi solenoid (9) opens, feeding LPG vapor through a pressure regulator (7) and then through the venturi nozzle (17). The LPG creates a pressure lower than atmospheric pressure in the venturi housing (6) as it exits the venturi nozzle. The air and the LPG streams are mixed and compressed in the diffuser section (18) and pressurize the accumulator. When the pressure in the accumulator reaches a preset level, the venturi solenoid valve (9) closes. As the mixed gas is used, the tank pressure drops, the venturi control switch (1) closes and the solenoid valve opens again to refill the tank.



**WARNING:**

The contactor that powers the heaters produces sparks which may ignite any propane vapors in the area when the control box cover is removed. If the cover must be removed, first shut off the power, remove the cover and check very carefully for LPG fumes, leaks or any indication of LPG in the atmosphere.



Do not re-apply power if LPG fumes are present.  
They may ignite!

Keep a fire extinguisher available in the immediate vicinity before re-applying power when the control cover is removed.

**This page intentionally left blank.**

## LIQUID LINE REFERENCE DRAWING

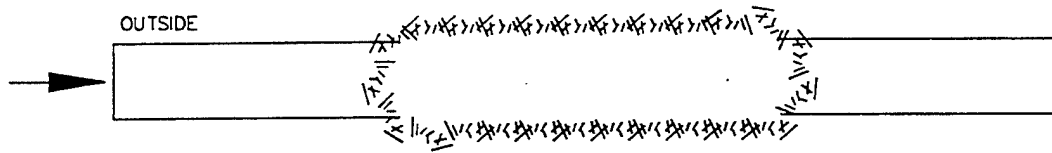

FROST ON LIQUID LINE

### NOTE:

Frost on the liquid line indicates propane is vaporizing due to a restriction that causes a pressure drop.

If the inlet pipe is too small, the LPG vaporizes before it enters the vaporizer causing a drastic drop in efficiency.

Wrong size inlet pipes can reduce output as much as 50%. When referring to the line sizing chart, note that the pipe sizes recommended are minimum size.

Restrictive valves or other devices may also cause frosting on the liquid line resulting in a pressure drop.

If pressure drop is excessive a liquid pump may be required.

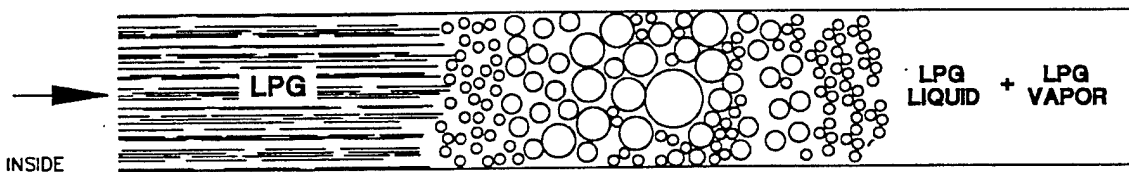

LPG VAPORIZES IF INLET PIPE IS TOO SMALL -

A. **LIQUID LINE**

Size the liquid line from the storage tank to the vaporizer to supply the vaporizer at full capacity with a minimal pressure drop. A liquid line sizing chart is provided on page 7. Install a liquid line strainer with magnet at the vaporizer inlet.



**CAUTION:**

**A liquid pump must be installed if the pressure drop in the liquid line exceeds the hydrostatic liquid head in the storage tank. ONE FOOT OF LIQUID PROPANE EQUALS .21 PSI! Liquid line frosting is a sure indication of too much pressure drop in the liquid line.**

B. **LIQUID PUMP**

Pressure in the LPG storage tank depends on ambient temperature. Install an S.D.I. **STABILAI**RE liquid pump beneath the storage tank if the saturation pressure is inadequate. Refer to the data sheet provided in Appendix C of the manual to determine the pressure required for your specific system.

C. **SAFETY RELIEF VALVE**

Always install the raincap or similar device (if removed) to prevent water and other debris from entering the relief valve discharge port. If water enters, it may freeze and prevent the relief valve from proper discharge, creating a potentially hazardous situation.

D. **ELECTRICAL SERVICE**

The data sheet in Appendix B of this manual provides proper electrical power requirements, wiring diagrams and schematics. This unit meets Class I, Division 1, Group D requirements. Wiring to the unit must meet the applicable codes for the area in which it is being installed. Provide a fused disconnect outside of the classified area. If it is not within sight of the vaporizer, it must have a locking device. Run wire within rigid conduit (see page 8 for recommended wire sizing chart), and install a seal-off at the connection of the field conduit to the vaporizer. The seal-off must be installed within 18" of the enclosure connection point.

***Install in accordance with applicable codes and local regulations as required.***

## LPG LIQUID LINE SIZING CHART (MINIMUM PIPE SIZE)

System Size	Distance in feet from storage to vaporizer*							
	25	50	75	100	150	200	300	400
XPV2.5 through XPV7.0	3/4"	3/4"	1"	1"	1"	1 1/4"	1 1/4"	1 1/4"
XPV10.5	1"	1"	1 1/4"	1 1/4"	1 1/4"	1 1/2"	1 1/2"	1 1/2"
XPV14.0	1"	1 1/4"	1 1/4"	1 1/4"	1 1/4"	1 1/2"	1 1/2"	1 1/2"
XPV21.0	1"	1 1/4"	1 1/4"	1 1/4"	1 1/2"	1 1/2"	1 1/2"	1 1/2"
XPV28.0	1"	1 1/4"	1 1/4"	1 1/2"	1 1/2"	1 1/2"	1 1/2"	1 1/2"

## EQUIVALENT PIPE LENGTH OF VARIOUS VALVES AND FITTING LENGTH IN FEET

Size/Description	1/2"	3/4"	1"	1 1/4"	1 1/2"
Globe Valve	15.5	21	27	36	43
Gate Valve	.6	.8	1.0	1.4	1.6
Angle Valve	8	11	14	18	21
Elbow, 90	1.4	1.9	2.4	3.2	3.8
Elbow, 45	.7	1.0	1.2	1.6	2.0
Elbow, 90 STR	2.3	3.1	4.0	5.3	6.3
Tee	2.7	3.7	4.8	6.4	7.5

\* Add equivalent length of all valves and fittings to the length of pipe. Use this value from the tables shown above to determine minimum pipe size.

## XPV RECOMMENDED WIRE SIZING CHART\*

VAPORIZER MODEL	XPV2.5 through XPV7.0		XPV10.5		XPV14.0	
VOLTAGE	LINE CURRENT	WIRE SIZE	LINE CURRENT	**WIRE SIZE	LINE CURRENT	***WIRE SIZE
208	49.7	6				
220	52.6	4				
240	57.3	4				
380	30.3	8	45.3	6	59.6	4
415	33.1	8	49.5	6	54.8	4
440	26.3	8	39.4	8	51.8	6
480	28.7	8	42.9	6	47.5	6

### NOTES:

\*Recommended minimum AWG wire size, based on one conductor per phase, three line conductors maximum per conduit, 75° C rated wire, and a maximum wire length of 150 ft. Wire sizing must be based on 125% of rated load and 3% maximum voltage drop. Use Class B or class C stranded wire with untinned ends.

\*\*The XPV 21.0 must have two power feeds since it requires two XPV 10.5 units to make the XPV 21.0.

\*\*\*The XPV 28.0 must have two power feeds since it requires two XPV14.0 units to make the XPV 28.0.

**MAJOR COMPONENTS DRAWING**  
**MODEL: 2.5 - 5# & 8#; MODELS: 10.5 - 5#, 8#, 12#; MODEL: 9.0 - 12#**

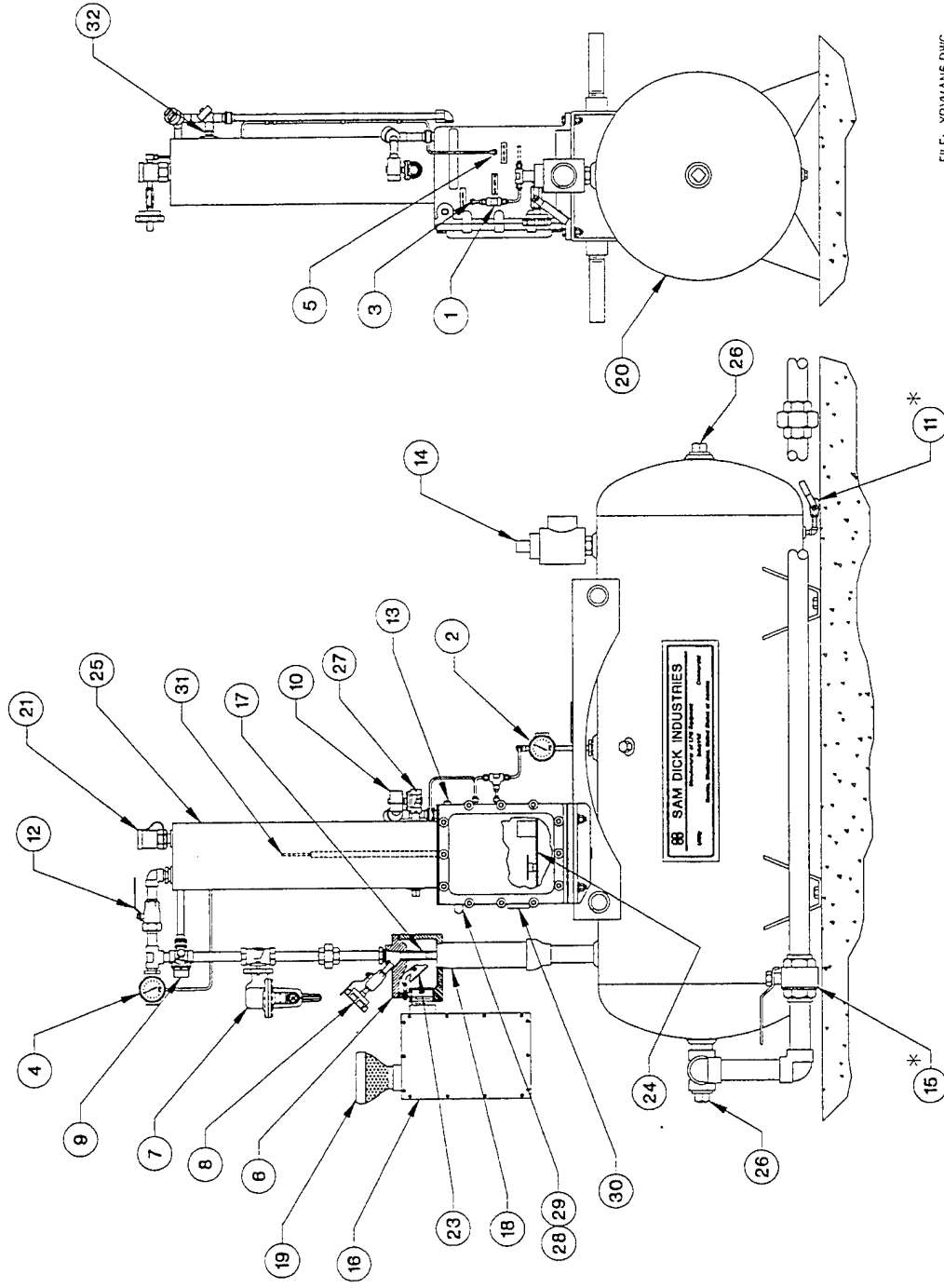

FILE: XPVMAN6.DWG

**MAJOR COMPONENTS DRAWING**  
**MODEL: 13.0 - 10#; MODEL: 14.0 - 5# & 8#**

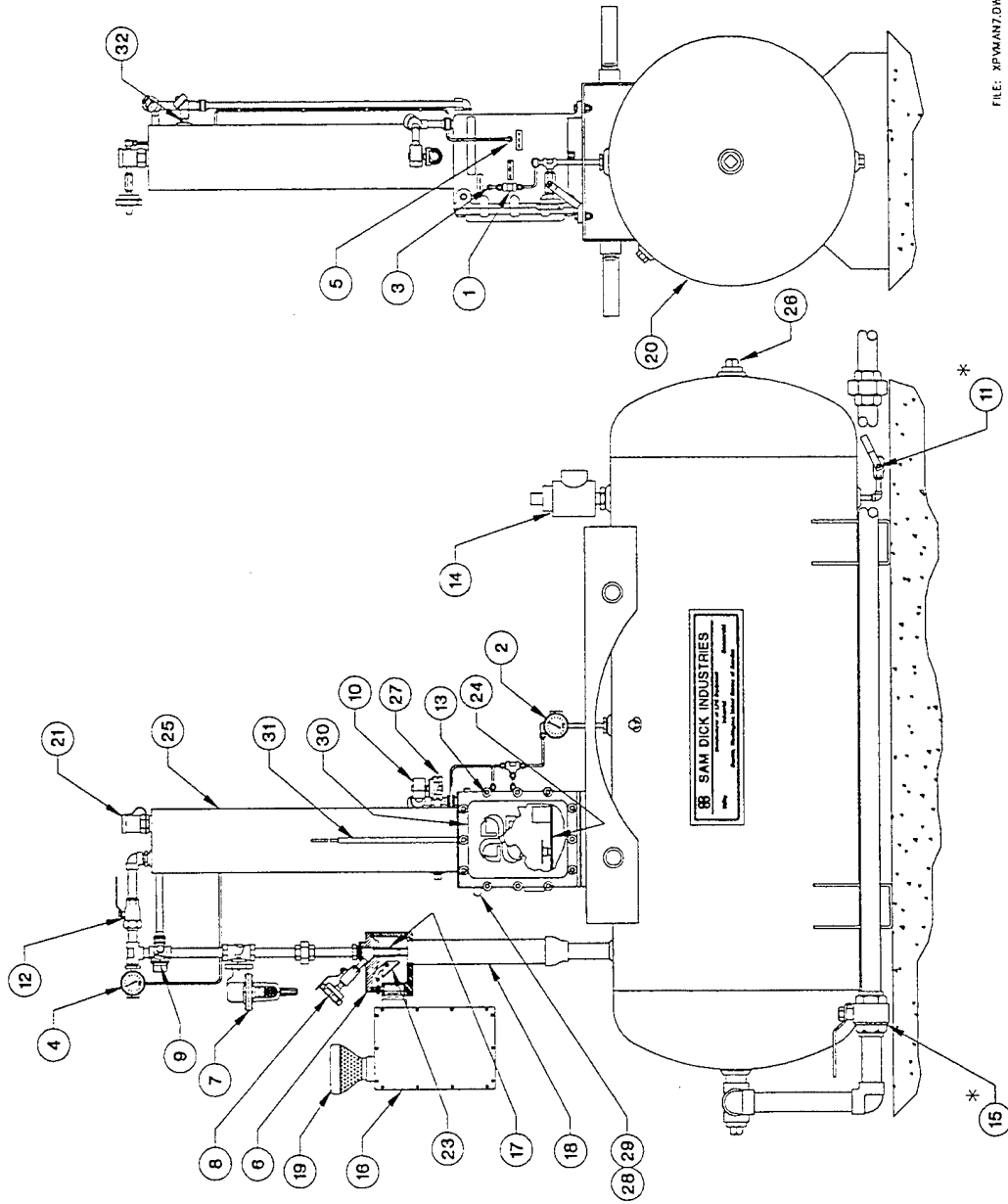

FILE: XPMAN7.DWG

**MAJOR COMPONENTS DRAWING**  
**MODELS: 14.0 & 18.0 - 12#; MODEL: 21.0 - 5#, 8#, 12#**

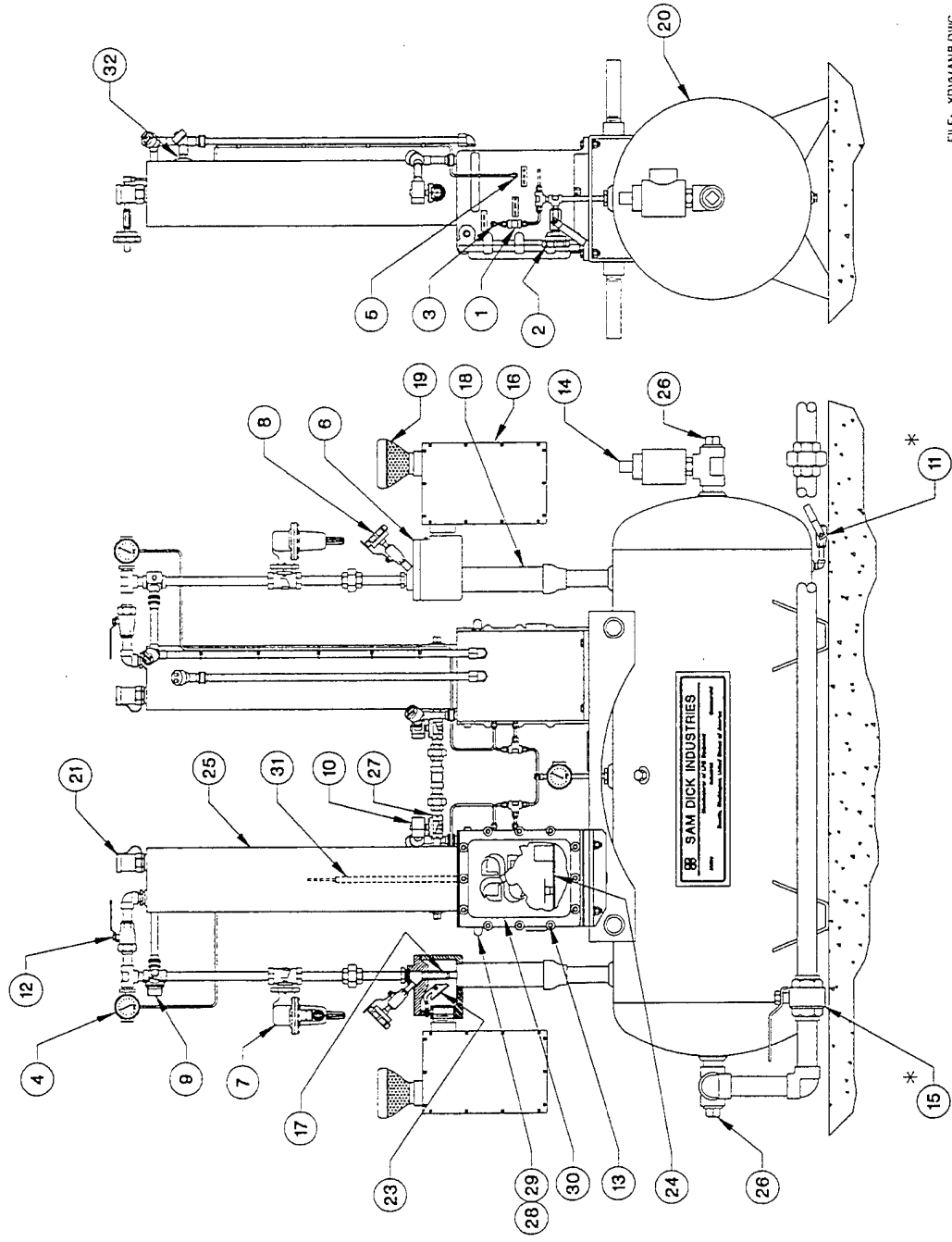

FILE: XPVMA18.DWG

**MAJOR COMPONENTS DRAWING**  
**MODEL: 26.0 - 10#; MODEL: 28.0 - 5#, 8#**

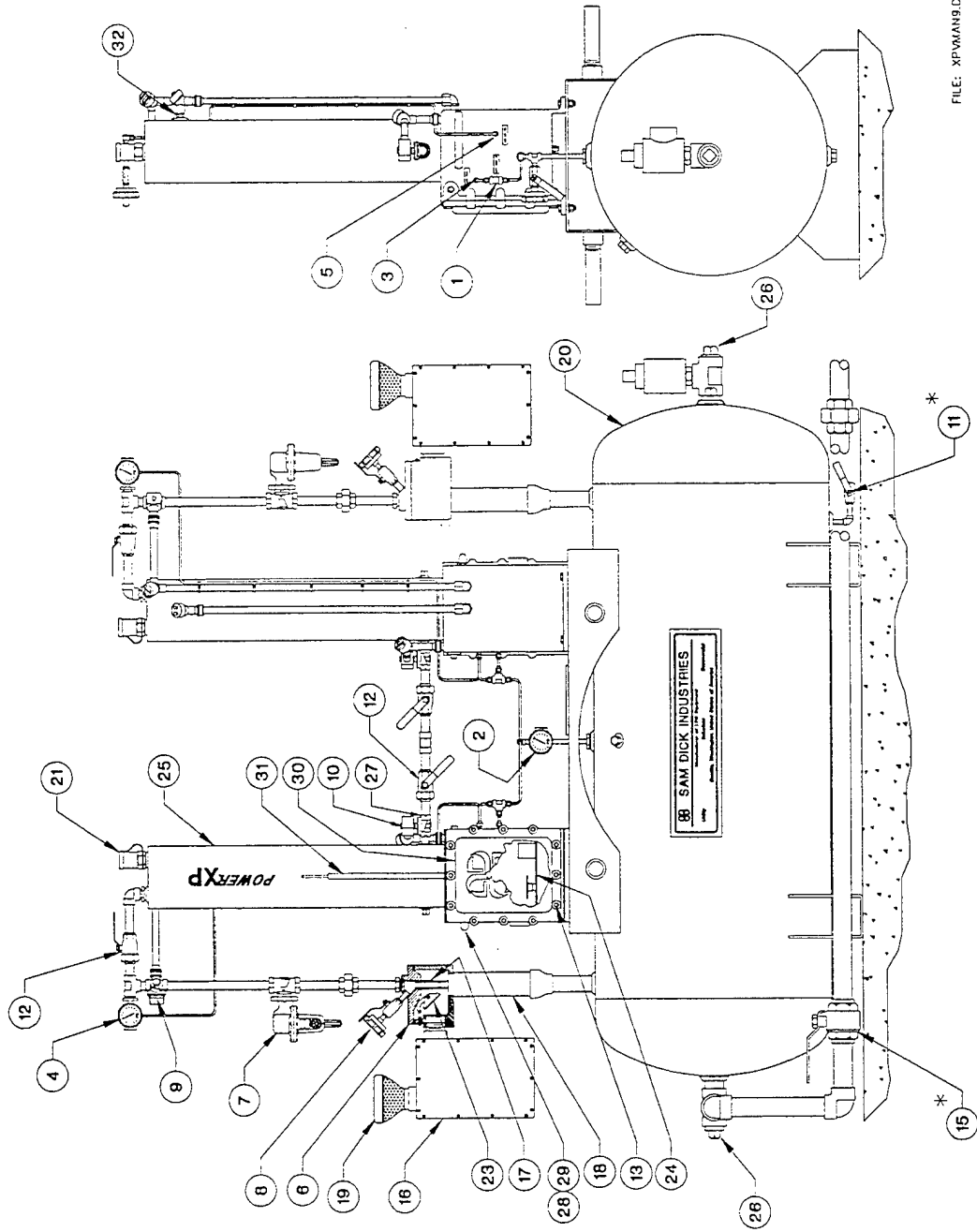

FILE: XPVMAN9.DWG

# MAJOR COMPONENTS DRAWING - CONTROL BOX MODELS 2.5 THROUGH 28.0

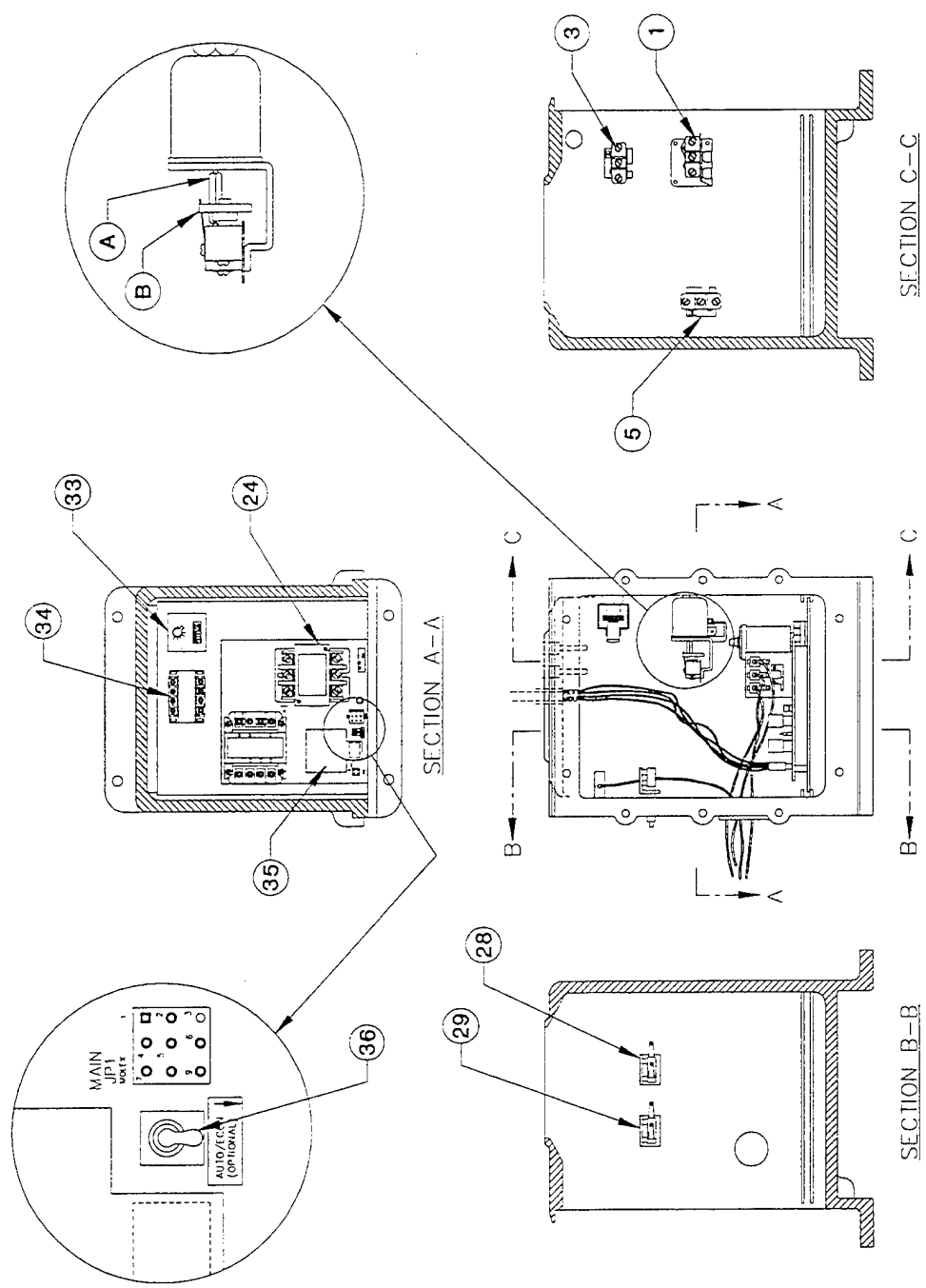

E. XPV MAJOR COMPONENT IDENTIFICATION  
(Ref: Pages 9 through 13)

1. Venturi Pressure Control Switch
  - A. "On" pressure adjustment
  - B. "Off" pressure adjustment
2. Mixed Gas Pressure Gauge
3. High Tank Pressure Switch
4. Inlet Vapor Pressure Gauge
5. Low Vapor Pressure Switch
6. Venturi Housing Assembly
7. Venturi Vapor Pressure Regulator
8. Venturi Motive Pressure Gauge
9. Venturi Vapor Solenoid Valve
10. Inlet Safety Solenoid Valve (closes with tank over-pressure)
11. Accumulator Tank Drain Valve (by others)
12. Venturi Shut-off Valve (vaporizer outlet shut-off valve), Isolation Valve
13. Control Box
14. Accumulator Tank Relief Valve
15. Mixed Gas Discharge Valve (by others)
16. Air Intake Silencer
17. Nozzle
18. Diffuser
19. Air Inlet
20. Mixed Gas Accumulator
21. Vaporizer Relief Valve
22. Accumulator Tank Mixed Gas Discharge Pressure Adjusting Screw
23. Air Intake Check Valve Assembly
24. Control Board Assembly
25. Vaporizer
26. Inspection Opening
27. LPG Inlet
28. Start Button
29. Stop Button
30. Electric Supply Connection Point
31. Vaporizer Temperature Sensor
32. Vaporizer Liquid Level Switch
33. Time Delay Relay
34. Venturi Control Circuit Transformer
35. Auto Restart Module (Optional)
36. Toggle Switch

# TYPICAL INSTALLATION DRAWING

## NOTES

1. BY OTHERS
2. INSTALL SYSTEM PER NFPA 58, 70 AND OTHER APPLICABLE CODES.
3. OUTLET AND RELIEF VALVE MAY BE REVERSED TO ALLOW FOR EASE OF PIPING INSTALLATION. THROUGH END OF TEE MUST REMAIN UNUSED TO ALLOW FOR INSPECTION.

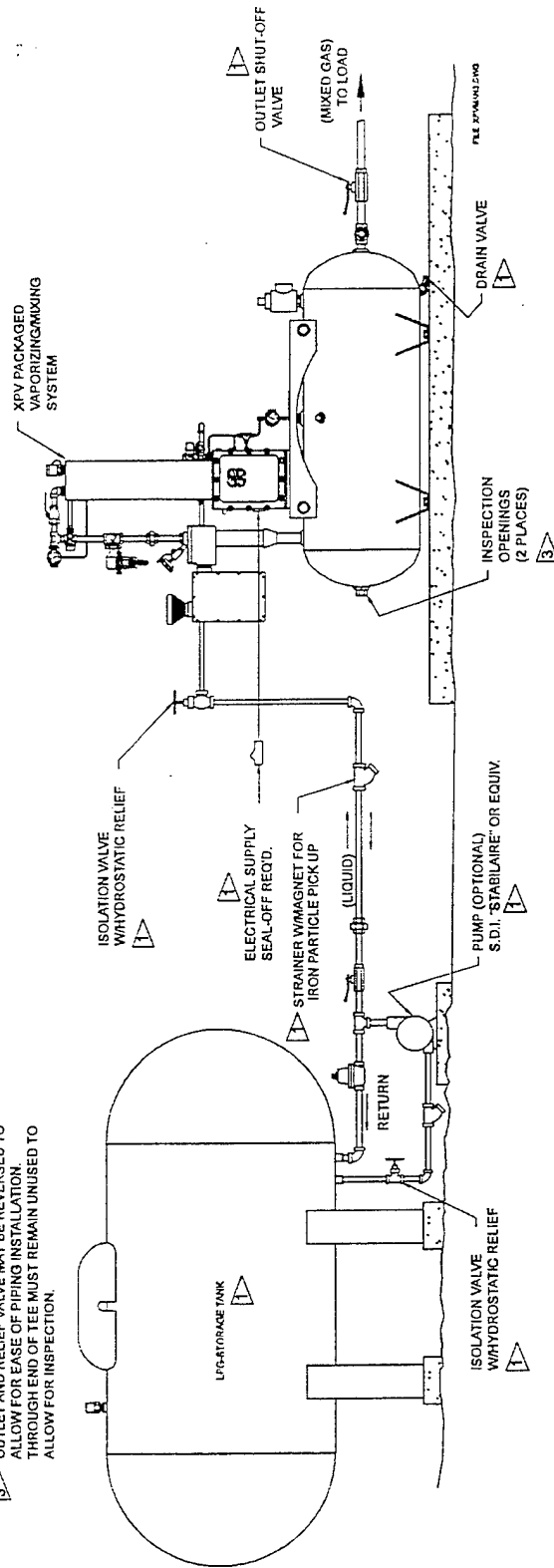

# TYPICAL INSTALLATION DRAWING

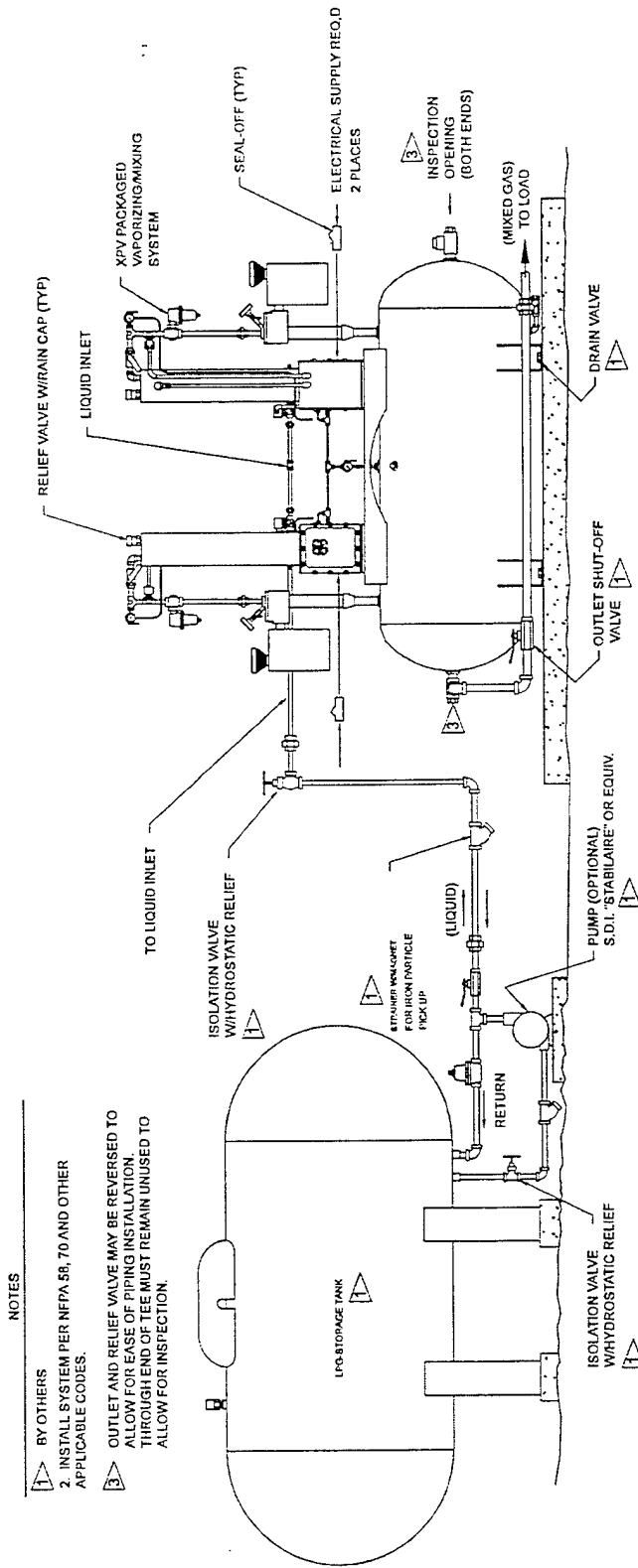

**NOTES**

- 1. BY OTHERS
- 2. INSTALL SYSTEM PER NFPA 58, 70 AND OTHER APPLICABLE CODES.
- 3. OUTLET AND RELIEF VALVE MAY BE REVERSED TO ALLOW FOR EASE OF PIPING INSTALLATION. THROUGH END OF TEE MUST REMAIN UNUSED TO ALLOW FOR INSPECTION.

MODELS XPV 21.0 THRU XPV 28.0

FILE SPANNING.DWG

### 3. INSTALLATION

(See pages 15 and 16 for typical installation drawings.)

- A. The XPV system is normally installed outside of plant buildings on a concrete pad. Install the XPV system on a level base and secure it through the four mounting holes. Use 1/2", grade 5 "J" bolts embedded in a concrete pad at least 6"x10"x8" thick. Protect the equipment against damage by moving vehicles by use of an appropriate barrier. Consult state, provincial, insurance carriers, and local authorities for installation requirements
- B. Electrical service must be provided to the control box (13) mounted on the surge tank (20). See data sheet in Appendix B for power and voltage requirements.
- C. Connect the liquid LPG line to the vaporizer inlet (27). Back flow of liquid from the vaporizer toward the tank is part of the normal operation of the vaporizer. **Do not install check valves in that line.** Install an SDI Stabilaire pump system if conditions require. Also install a strainer, with magnet for iron particle pick-up, before the inlet of the vaporizer with a size 40 or smaller wire mesh screen.
- D. Install a manual valve (15) after the mixed gas outlet and an isolation valve with a hydrostatic relief on the liquid inlet. Refer to the typical installation drawings (pages 15 and 16) for general layout indications.
- E. Connect the mixed gas outlet to the plant piping as required. A shut off valve and a back check valve should be installed between the connection point and the outlet of the accumulator tank.

Clean all foreign material from all pipe lines **prior** to making final connections. All joints require a pipe sealant approved for LPG. Test for leaks using an inert gas, such as compressed carbon dioxide or nitrogen, at approximately 100 PSIG [7 Kg/Cm<sup>2</sup>]. Check all connections using an appropriate leak detection solution or device. **Even very small leaks are unacceptable!** Eliminate all leaks prior to operation.

- F. Install a small drain valve (11) in the plugged opening provided on the lower portion of the tank (20).
- G. Remove the four 2" pipe nipples that are provided to ease lifting.

#### 4. OPERATING INSTRUCTIONS

##### NOTE:

1. Complete the installation and leak test.
2. Check current and voltage to verify proper operation of the vaporizer. *See Procedure under Troubleshooting (Appendix A).*
3. Check operation of the inlet solenoid valve (10). *See Step 5 of the "Operating the XPV System" Procedure.*
4. This unit will **not** be damaged by operating the unit in a "dry" condition. It is not necessary to have LPG in the unit for testing or evaluation.
5. Normal operating temperature is about 195° F. [90° C.] for propane applications. *Use caution when working around vaporizer.*

##### A. OPERATING THE XPV SYSTEM

1. Close mixed gas outlet valve.
2. Open all valves between the LPG storage tank and the vaporizer (25) to allow liquid flow to the vaporizer (25). If a pump is required to achieve the necessary vapor pressure, start the pump and check the outlet pressure. Refer to the data sheet (Appendix B) for required vapor pressure.
3. Push the "Start" button (28) on the vaporizer. The vaporizer heater elements will then be energized, heating the body. When the heater core temperature attains 125° F. [52° C.], the inlet solenoid valve will automatically energize and the valve will open allowing liquid to enter the vaporizer body. It will take less than 60 seconds to reach a ready condition.
4. After another short delay the venturi will cycle, raising the pressure in the mixed gas accumulator (20) to the preset level. The unit is now ready to supply mixed gas and opening the outlet shutoff valve (15) will allow mixed gas to flow. The heaters and venturi(s) will cycle automatically to match flow conditions while the accumulator tank will insure continuous LPG/air supply.
5. **CAUTION:** Make an operational check of the inlet solenoid valve (10) once the vaporizer is started. **PROCEDURE:** *Press the stop switch (29). The valve (10) should stop the flow of gas as indicated by the loss of pressure at the vaporizer outlet (4). Pressing the start switch (28) should immediately restore operation.*

**B. STOPPING THE XPV**

1. Push the **STOP** button (29) on the vaporizer (25). This de-energizes and closes the inlet solenoid valve (10). Power is also disconnected from the heater elements.
2. For extended shutdowns, close the liquid withdrawal valve at the LPG storage tank while there is demand on the LPG system. After the LPG is drained from the line, turn off the electrical power at the disconnect and close the manual outlet valve (12) at the vaporizer outlet.

## 5. MAINTENANCE

The XPV packaged vaporizing/mixing system is designed for long term trouble free operation. Because of the nature of its use, and the heavy duty it receives, it is important to provide scheduled maintenance. We provide a **RECOMMENDED SPARE PARTS** list located in the back of this manual (see Appendix B).

ITEM	1 MONTH	3 MONTHS	6 MONTHS	ANNUALLY
*Liquid LPG Inlet Strainer	Clean		Check as conditions require	Check as conditions require
Safety Relief Valve(s) (14, 21)				Visually check.  Replace if any leakage is observed.
Inlet Solenoid (10)				Change the diaphragm and operating parts if the unit is being used regularly or if the valve makes unusual noises (i.e. buzzing, etc.) during operation.  See the enclosed maintenance & operation sheet for ASCO 2-way valves replacement procedure (Appendix A).
Electrical Wiring and Connections				Visually inspect for corrosion, loose wires, build-up and charring.
Low Vapor Pressure Switch (5) Set Points				Verify against the values on the data sheet
High Tank Pressure Switch (3) Set Points				Verify against the values on the data sheet
Venturi Check Valve Assembly (23)			Check for wear and leakage.	
Motive Pressure	Check set point	Check set point	Check set point	Check set point

\*The relief valves are **not** serviceable in the field. Be certain that the relief valve(s) has a cover over the outlet.

A. ADJUSTMENT PROCEDURES FOR SYSTEM OPERATING AND SAFETY CONTROLS

All of the controls (except for the venturi regulator) are preset at the factory. However, vibration in transportation may alter the settings or it may be desirable to change the system delivery pressure (within the range of the installed venturi). Thus the control settings may need to be checked or readjusted. Any replaced controls will also require adjustment.



**WARNING:**

The pressure control switch (1) is mounted in an explosion-proof control box (13). The box also contains electronic devices capable of producing electrical sparks when they are activated. Power to the control box must be turned off at a remote disconnect before the cover is removed. Check for propane leaks before applying power.



**WARNING:**

Most of these operations require the control enclosure to be open while the circuits are tested. (Refer to system operation manuals.) At all times make absolutely sure no LPG vapor is present around the enclosure. The electrical arcing that occurs when the various switches and relays within the enclosure operate is a possible source of explosive ignition.



**WARNING:**

***DO NOT APPLY POWER IF LPG FUMES ARE PRESENT. THEY MAY IGNITE!***



**WARNING:**

Do ***NOT*** attempt to adjust the pressure switches with the power turned on.



**WARNING:**

Always have a fire extinguisher handy when operating with the control enclosure open.

1. **MOTIVE PRESSURE (set pressure of the venturi regulator)**

The motive pressure for the venturi is stamped on the base of the venturi housing (6). This pressure is adjusted using the vapor pressure regulator (7) on the LPG vapor train. The adjustments should be made with the system in operation, using an SDI LP-1000 BTU Meter while adjusting the Motive Pressure (8) and monitoring the LP-1000 to attain a 1450 BTU/cu. ft. mix. See page 27.

<b>(PROPANE) PRESSURE REQUIREMENT DATA</b>		
<b>MIXED AIR/PROPANE DELIVERY PRESSURE PSIG (KG/CM<sup>2</sup>)</b>	<b>INLET VAPOR PRESSURE PSIG (KG/CM<sup>2</sup>)</b>	<b>*NOZZLE MOTIVE PRESSURE PSIG (KG/CM<sup>2</sup>)</b>
5.0 (.35)	45.0 (3.2)	35-40 (2.5-2.8)
8.0 (.56)	90.0 (7.0)	75-80 (5.1-5.4)
10.0 (.70)	130.0 (9.1)	110-115 (7.7-8.1)
12.0 (.84)	140.0 (11.2)	110-130 10.2-12.5)

**\*Refer to data sheet for specific settings  
CONTACT FACTORY FOR ADDITIONAL INFORMATION  
AND FOR DATA ABOUT BUTANE/PROPANE LPG MIXTURES**

2. **SYSTEM DELIVERY PRESSURE**

***Pressure Control Switch (1)***

The system delivery pressure (within the range of the installed venturi) is set by means of the tank pressure adjustment screw (Item 22). The on/off differential pressure is set by means of Item 22.

To adjust the switch, use a 1/4" open end wrench, turn the main adjustment screw counterclockwise to lower the setpoint or clockwise to raise the setpoint. Turn the adjusting screw until the "ON" setpoint is reached, then set the differential adjustment for a deadband (off) of .75 to 1 psi. A typical setting is between E and F. See Appendix A for additional adjustment information.

Delivery pressure is indicated on the mixed gas pressure gauge (2). See the chart on the next page for set points.

SYSTEM DELIVERY PRESSURE SET POINTS						
XPV 2.5 - XPV 14.0						
DELIVERY PRESSURE	VENTURI "ON" (PSIG)	VENTURI "OFF" (PSIG)		DEADBAND	DEADBAND POSITION	
5#	5	5 3/4 -6		.75 -1	E -F	
6#	6	6 3/4 -7		.75 -1	E -F	
8#	8	8 3/4 -9		.75 -1	E -F	
10#	10	10 3/4 -11		.75 -1	E -F	
12#	12	12 3/4 -13		.75 -1	E -F	
XPV 21.0 - XPV 28.						
DELIVERY PRESSURE	#1 ON (PSIG)	#1 OFF (PSIG)	#2 ON (PSIG)	#2 OFF (PSIG)	DEADBAND	DEADBAND POSITION
5#	5	5 3/4	5 1/4	6	.75	E -F
6#	6	6 3/4	6 1/4	7	.75	E -F
8#	8	8 3/4	8 1/4	9	.75	E -F
10#	10	10 3/4	10 1/4	11	.75	E -F
12#	12	12 3/4	12 1/4	13	.75	E -F

### 3. HIGH TANK PRESSURE SWITCH

The pressure switch (3) is located in the control box (13). To set, turn adjusting wheel to approximate setting shown on indicator scale on the switch. The set points for the high tank pressure switch in the control box are as follows:

HIGH TANK PRESSURE SWITCH SET POINTS	
MIXED AIR/PROPANE DELIVERY PRESSURE	HIGH TANK PRESSURE SWITCH
5 PSIG	8 PSIG
6 PSIG	9 PSIG
8 PSIG	1# PSIG
10 PSIG	1# PSIG
12 PSIG	15 PSIG

4. **LOW VAPOR PRESSURE SWITCH**

With the system operating, slowly throttle the vaporizer LPG vapor outlet valve (12). This reduces the LPG vapor pressure being sent to the mixer. Observe the LPG vapor pressure gauge (4) and note the pressure at which the low vapor pressure switch (5) opens and disables the venturi solenoid valve. To set the low vapor pressure switch, turn the adjusting wheel to the approximate setting shown on the indicator scale on the switch body. The set points are shown below. Repeat the process to verify the setpoint. Note that the low vapor pressure switch only disables the venturi solenoid valve and does not shut off the XPV.

LOW VAPOR PRESSURE SWITCH SET POINTS	
MOTIVE PRESSURE	LOW VAPOR PRESSURE SWITCH
35-40 PSIG	40-45 PSIG
65-70 PSIG	75-80 PSIG
110-115 PSIG	120-125 PSIG
110-140 PSIG	120-150 PSIG

*Low pressure*

# VENTURI CHECK VALVE ASSEMBLY

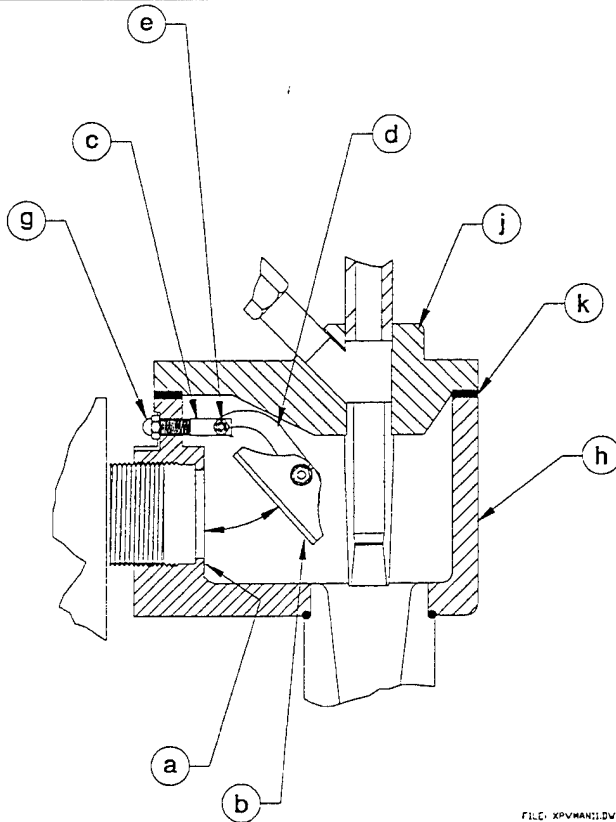
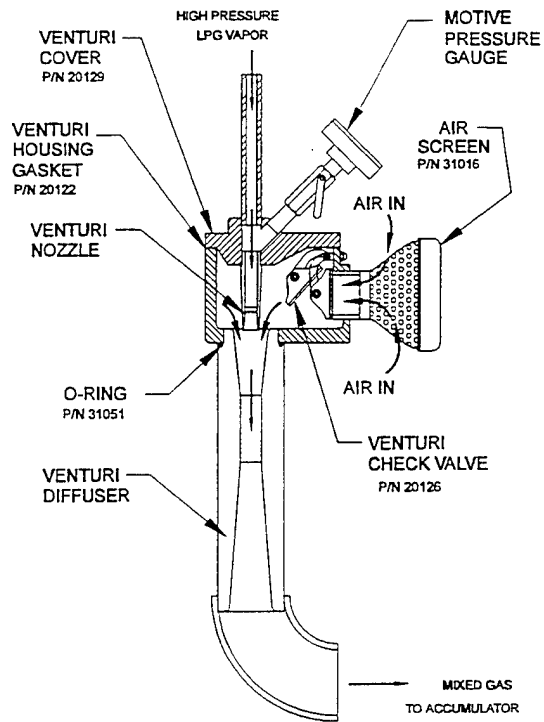

FILE: XPMAN1.DWG

## B. VENTURI CHECK VALVE INSTALLATION INSTRUCTIONS

If the venturi check valve leaks or the pivot mechanism operates poorly, the venturi check valve assembly must be replaced. Follow the procedure below to replace the venturi check valve and pivot arm.

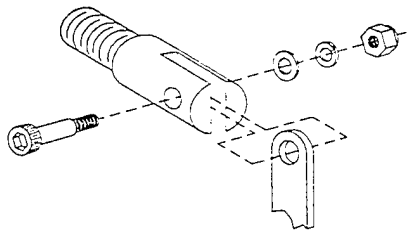

1. After the existing check valve (b, c) has been removed, examine the machined seating surface (a) on the venturi housing (h) to be sure the surface is clean and without flaws.
2. Insert the check valve arm (d) into the slot of the clevis and connect the two pieces with the clevis/arm pivot screw through the aligned holes. Be sure that the lock washer and a flat washer are inserted on the lock nut end (with the lock washer next to the lock nut) and a flat washer on the other end. Tighten the lock nut (e), allowing for free swing of the arm.
3. Screw the clevis (c) into the housing, using Permatex No. 1 or equivalent on the threads, until 3-3 1/2 threads are exposed outside of the housing. Do not use a screwdriver or other prying device to install the clevis.

4. Check for proper clevis installation as follows:

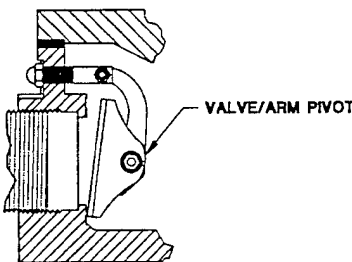

- a. With the arm (d) raised, rotate the valve (b) around the valve/arm pivot so that the edge of the valve nearest the clevis is lowered without allowing the valve (b) to turn around the valve/arm pivot; only the lower part of the valve should contact the seating surface (a).

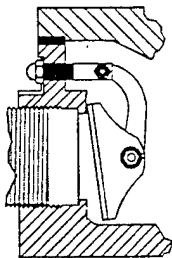

- b. With the valve (b) rotated to the other extreme position around the valve/arm pivot, lowering the arm (d) should cause only the upper part of the valve (b) to contact the seating surface (a).

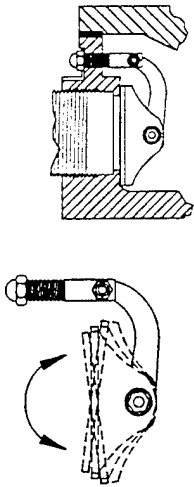

- c. Lower the arm (d) a third time, allowing free rotation of the valve (b). The valve (b) should be able to contact the seating surface (a) uniformly all around.
  - d. If the valve does not contact the seat as described above, reposition the clevis (c) in the housing (h). At least three threads must be exposed for proper installation of the acorn nut (g).
5. Tighten the acorn nut (g) onto the clevis (c) outside the housing (h), making sure that the nut is tight, the valve is centered. Do not use any tools on the clevis inside the housing, or on the arm or valve. It may be helpful to start with the valve offset to the side and allow it to rotate to its centered position while tightening the acorn nut.
  6. Tighten the lock nut (e) on the clevis/arm pivot screw until the arm is tight in the clevis. Then slowly loosen the lock nut just until the arm can swing freely. Check that the valve is centered and clears the housing on both sides.
  7. Install the venturi housing lid (j), using a new gasket (k).
  8. Apply pressure to the unit and check for leaks around the lid and around the check valve. Initially a small leak may occur around the check valve, but after a few cycles the leak should correct itself. If it persists, remove the lid and re-check the seating surfaces and the alignment.

**AS WITH ALL COMPONENTS CONTAINING MATERIALS SUBJECT TO DETERIORATION, THE VENTURI CHECK VALVES SHOULD ROUTINELY BE CHECKED AND REPLACED AS NECESSARY. A MINIMUM ANNUAL INSPECTION SHOULD BE CONDUCTED.**

C. LEAK CHECK PROCEDURE FOR VENTURI CHECK VALVES

1. Remove silencer from venturi.
2. Build up pressure in the surge tank to the system operating pressure, shut off the system, close the inlet valve, and disconnect all power.
3. Use either a gas detector or a soapy solution applied to the check valve and seat to determine if there is a leak.
4. If there is a slight leak from the venturi check valve, tapping the valve open quickly with a screwdriver or suitable tool may dislodge a small particle on the lip of the valve. Otherwise the venturi must be disassembled and the check valve and valve face cleaned and the valve arm pivot adjusted as outlined in an earlier section of the manual.
5. When assembling the silencer into the venturi housing, use an anti-seize compound on the threads.



WARNING:

LPG is heavier than air and LPG vapor either mixed with or without air will "pool" in low areas without ventilation or wind. Check potential "pooling" areas with a gas detector if gas is suspected.

D. **BTU ADJUSTMENT PROCEDURE** (Refer to Major Components Drawings)

1. System is "ON" and ready for operation with **NO** load.
2. Begin taking gas samples from the accumulator tank (20) using a BTU indicator.
3. Introduce load to the system. The frequency of the venturi cycling should be approximately 50/50. ("ON" 50% of the time, "OFF" 50% of the time).
4. Verify that the LPG vapor motive pressure (8) and the mixed gas tank pressure (2) are set at the correct pressure. See pg. 22 for LPG motive pressure settings. Adjust the LPG vapor regulator (7) if adjustment is required. See pg. 23 for mixed gas tank pressure settings. Adjust items 1A and 1B if adjustments are required.
5. Let the system operate a sufficient length of time in order for the BTU indicator to stabilize.
6. Repeat step 4 as necessary until the proper motive pressure and BTU value are achieved. Due to the physical properties of venturis, as the motive pressure is increased, the LPG flow rate increases accordingly. If the motive pressure is set too high, it may overdraw the vaporizer. A general rule of thumb is not to exceed the motive pressure stamped on the venturi housing by more than 5 psig.
7. Increase the system load and verify the mixed gas BTU value.

## TROUBLESHOOTING GUIDE

The troubleshooting guide for the Sam Dick Industries XPV Vaporizer/Mixing System is presented in seven trees:

- Tree #1 & #2 - System does not start
- Tree #3 - System starts but will not stay on
- Tree #4 - System starts but venturi/mixer does not operate
- Tree #5 - System starts, cycles once, and shuts down
- Tree #6 - Liquid solenoid valve doesn't open
- Tree #7 - Intermittant shutdown of system

Additional information on replacing and adjusting components can be found in the vendor parts information in Appendix A.



**WARNING:**

High voltage is present throughout the control enclosure even if the unit is turned off! You must shut off the power at the disconnect before you can safely reach into the enclosure to do anything!



**WARNING:**

The contactor that powers the heaters produces sparks which may ignite any propane vapors in the area when the control box cover is removed. If the cover must be removed, shut off the power, remove the cover and check very carefully for LPG fumes or any indication of LPG in the atmosphere.



**WARNING:**

Do not re-apply power if LPG fumes are present. They may ignite!



**WARNING:**

Keep a fire extinguisher available in the immediate vicinity before re-applying power when the control cover is removed.

**NOTE:** Do not test AC power by going from the ground to the power lead. This could produce an erroneous reading. Check from one power lead to another.

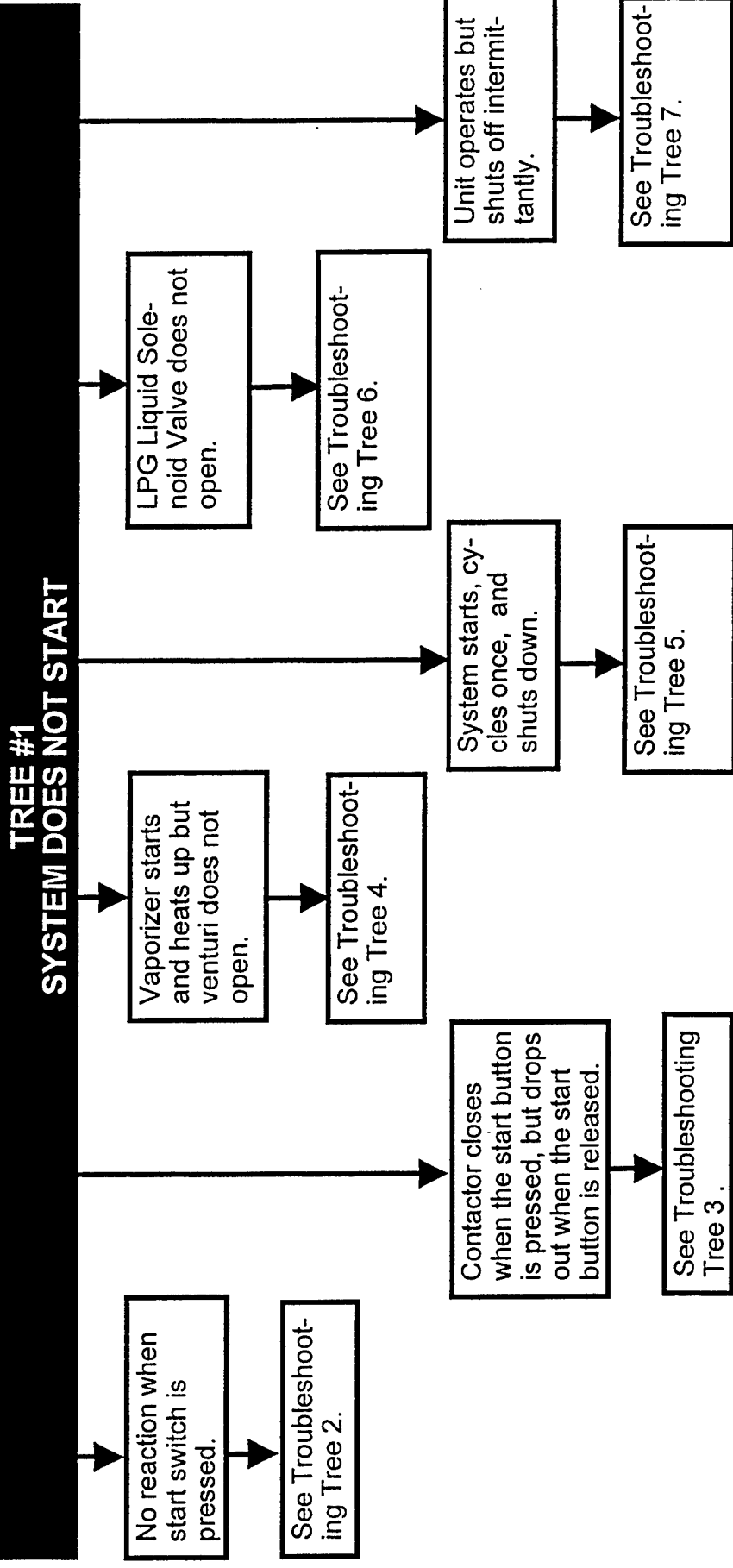

# TREE #2 NO REACTION WHEN START SWITCH IS PRESSED

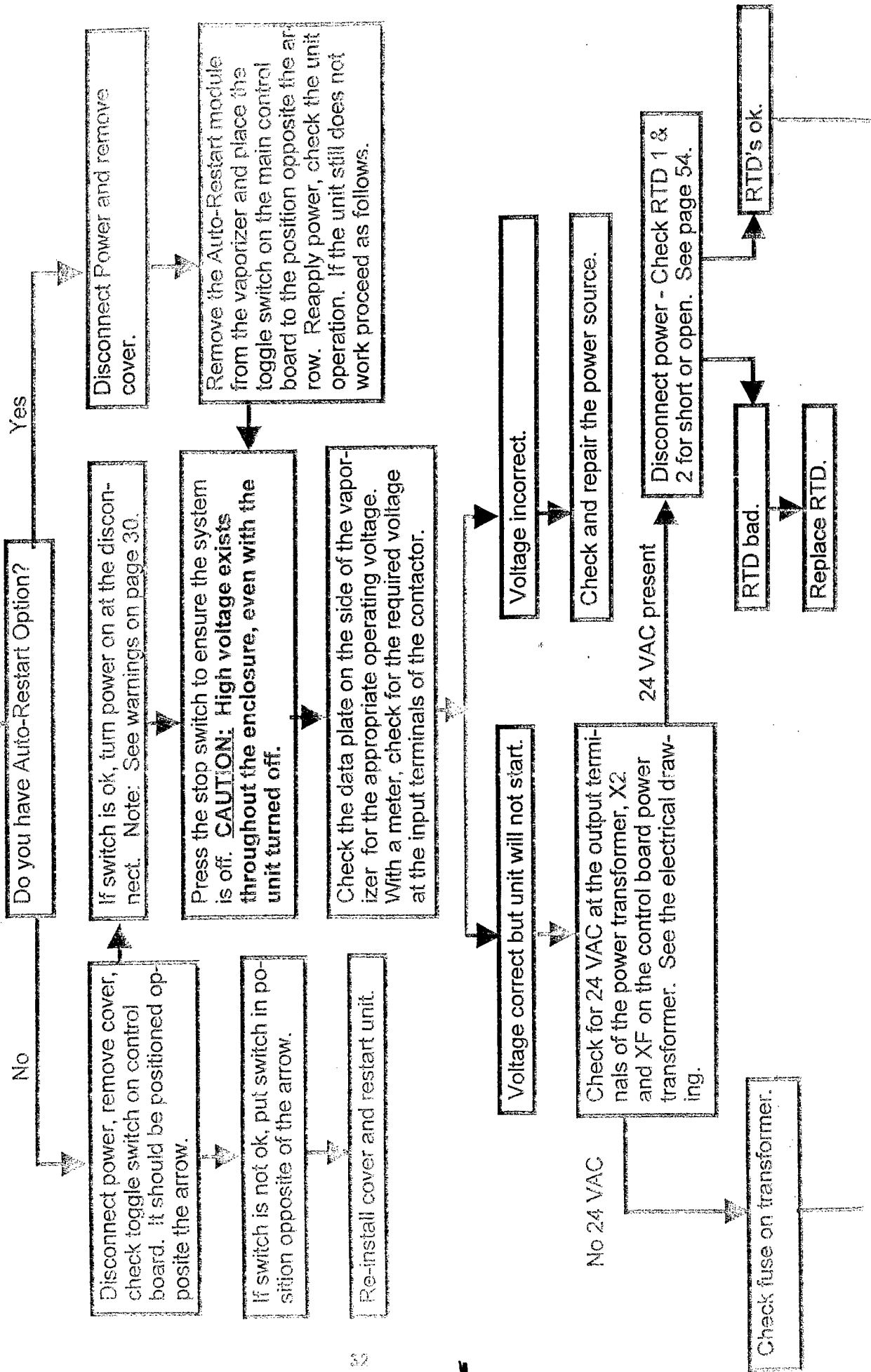

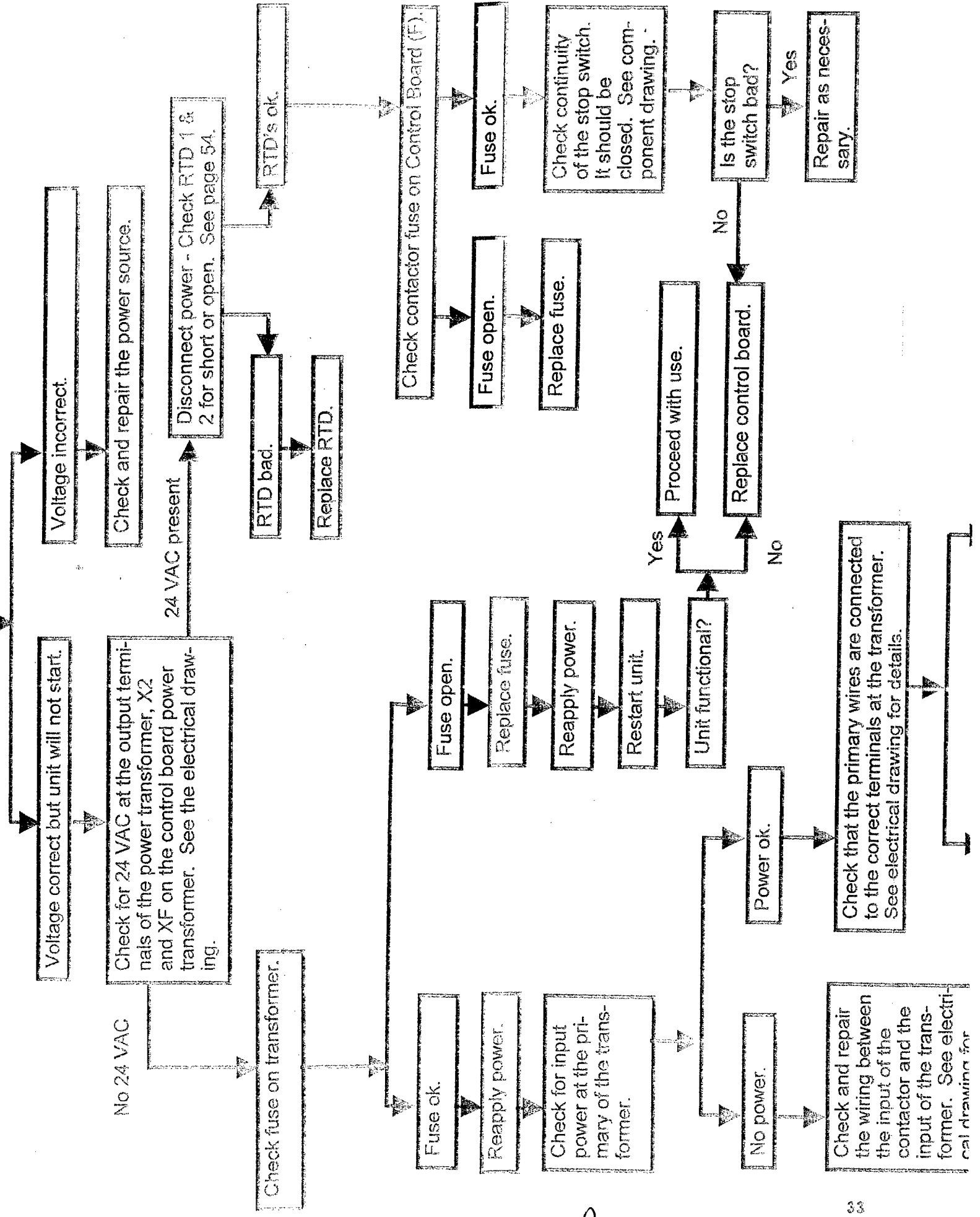

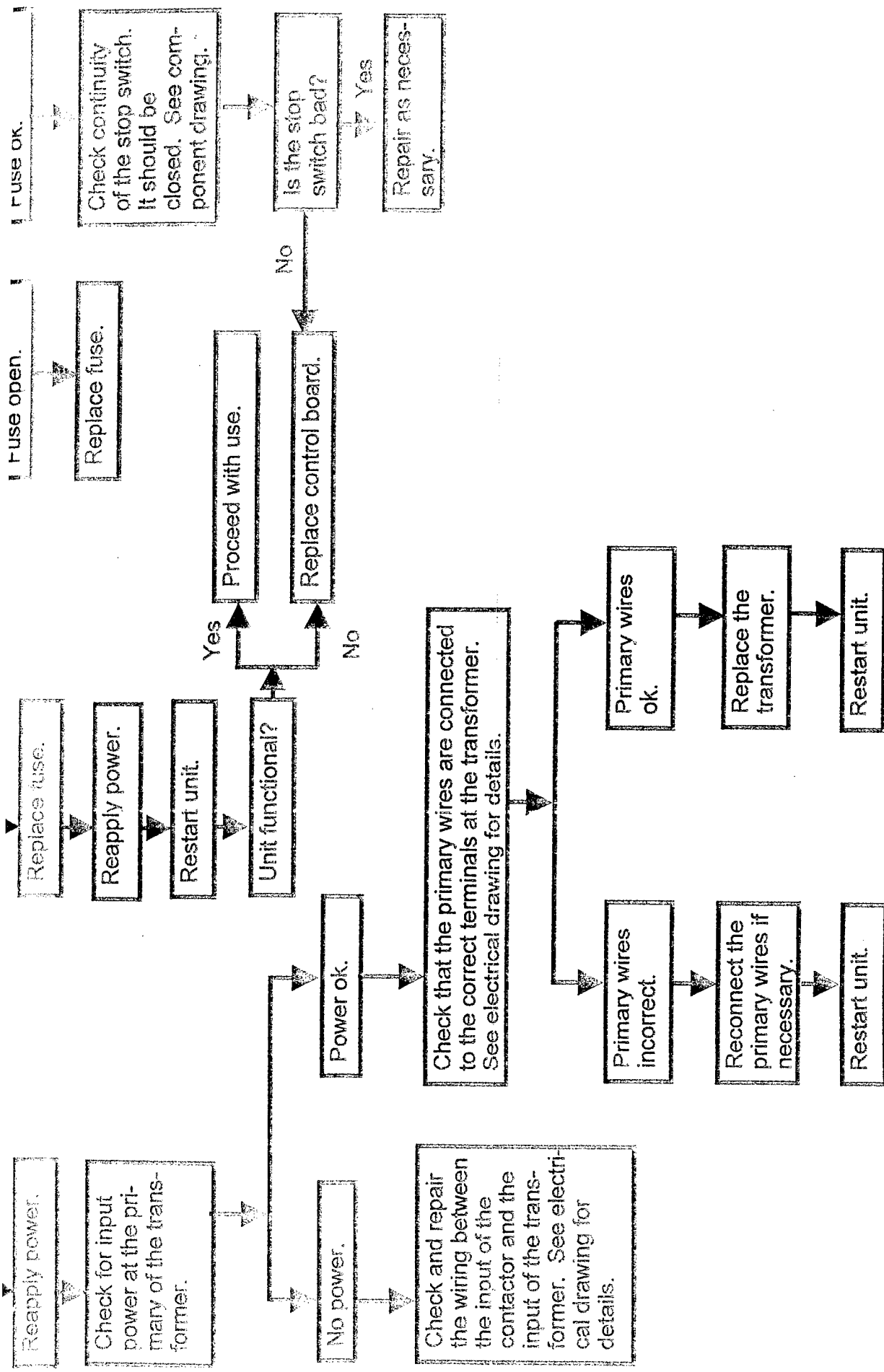

**TREE #3**  
**CONTACTOR CLOSSES WHEN THE START BUTTON IS PRESSED, BUT DROPS OUT WHEN THE BUTTON IS RELEASED.**

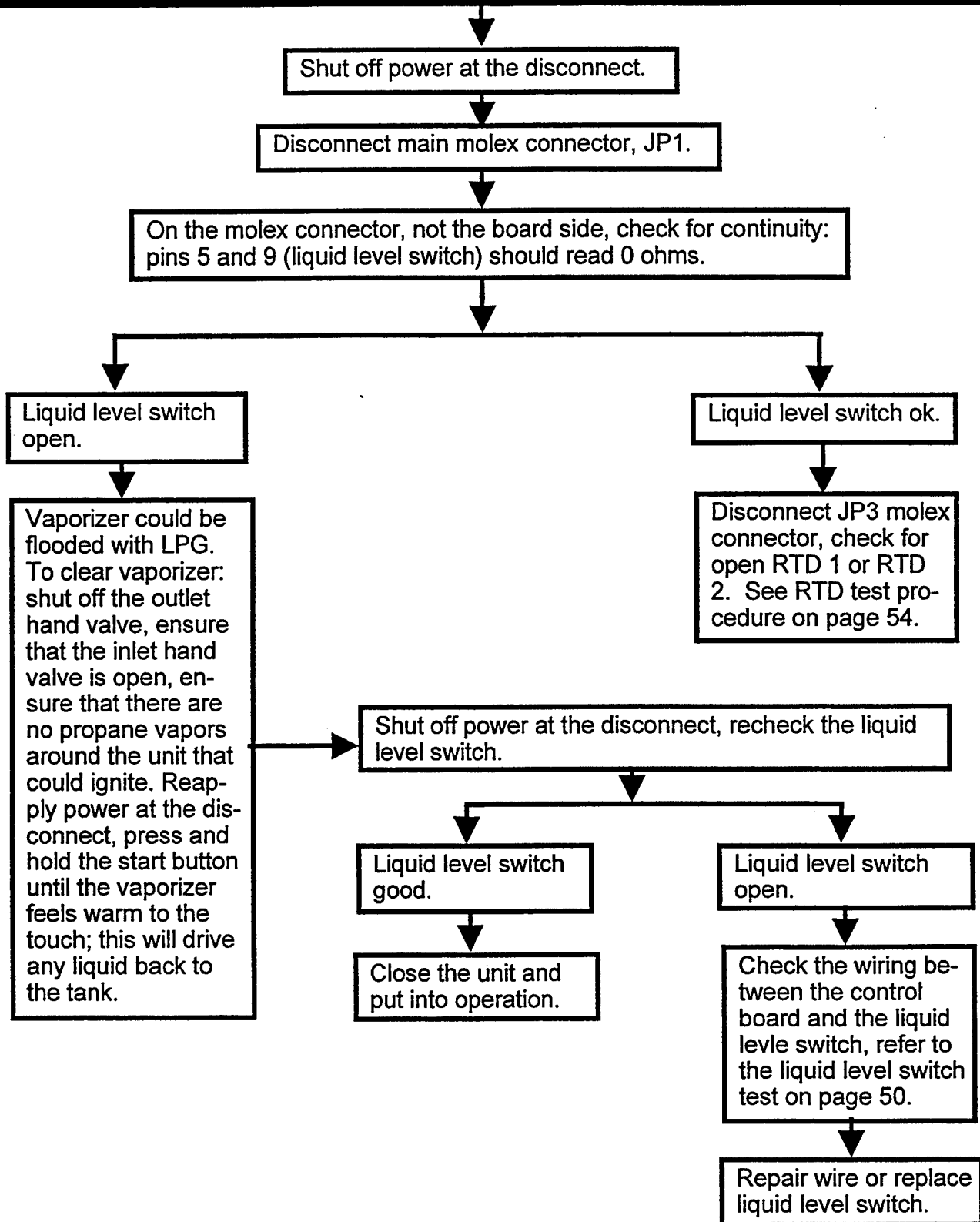

# TREE #4 VAPORIZER STARTS AND HEATS UP, BUT VENTURI MIXER DOES NOT OPERATE

Disconnect power at the disconnect, open the control enclosure, connect the meter to XF and X2 on the venturi power transformer, set the meter on 24 VAC. Reapply power, but do not press the start switch, meter should read 24 VAC. NOTE: Read WARNINGS on page 30.

Meter does not read 24 VAC.

Disconnect power. Connect meter leads to the primary leads of the mixer transformer. CAUTION: This is high voltage. Re-apply power.

No high voltage.

Disconnect power.

Repair wiring between the power contactor and the transformer.

Retest unit.

High voltage good.

Replace transformer fuse or replace transformer.

Retest unit.

Meter reads 24 VAC.

Disconnect power. Remove meter lead from XF and connect it to the normally open contact of the low vapor pressure switch. NOTE: See WARNINGS on page 30. Press the start switch. The meter should read 24 VAC.

Meter does not read 24 VAC.

Low vapor pressure switch is open.

Check vapor pressure.

Vapor pressure good.

Replace vapor pressure switch.

Vapor pressure low.

Repair vapor pressure source.

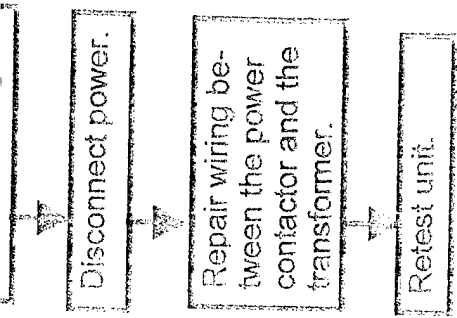
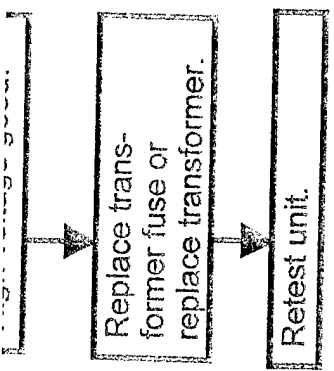
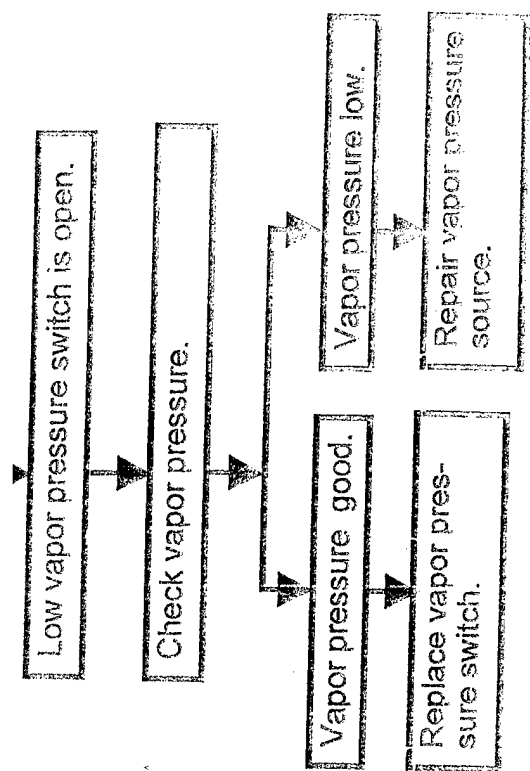

Meter reads 24 VAC.

Disconnect power. Move meter lead to the common of the venturi pressure control switch. Reapply power, press start switch. After 5 seconds the meter should read 24 VAC.

Meter reads 24 VAC.

Disconnect power. Move meter lead to NC contact of venturi pressure control switch. Reapply power. After 5

Meter does not read 24 VAC.

Replace Time Delay Relay (TDR).

Disconnect power.  
Move meter lead to the common of the venturi pressure control switch. Reapply power, press start switch. After 5 seconds the meter should read 24 VAC.

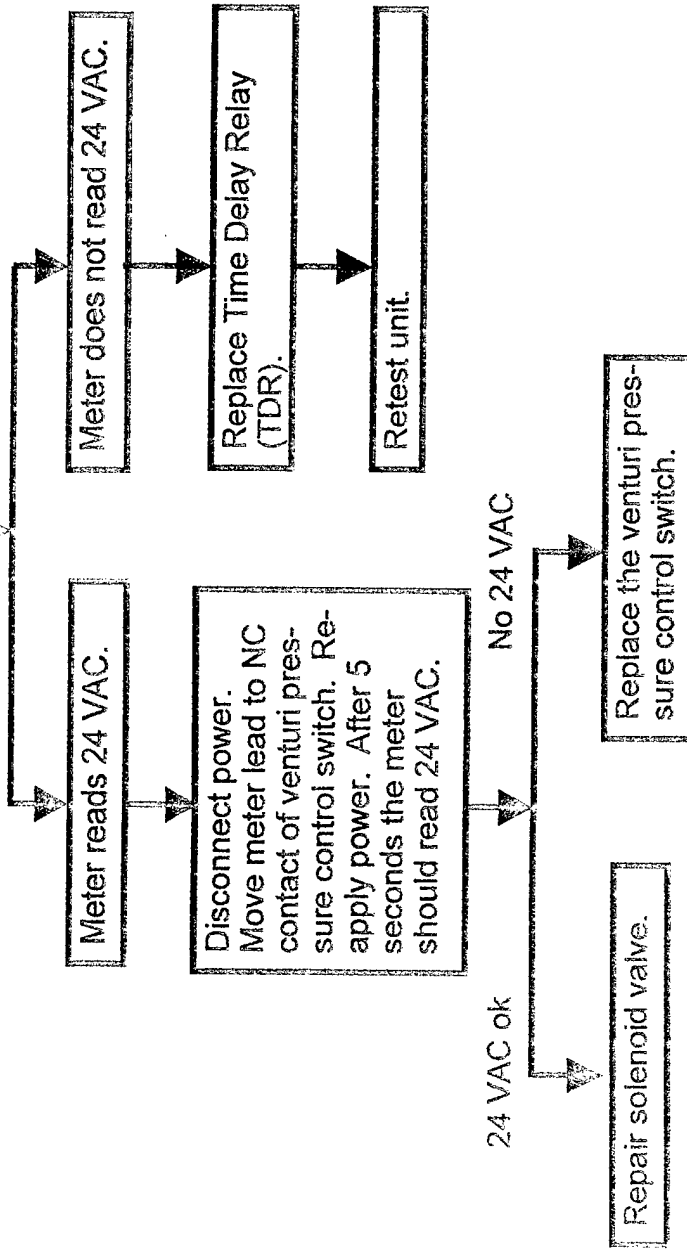

**TREE #5  
XPV STARTS, CYCLES ONCE AND SHUTS DOWN.**

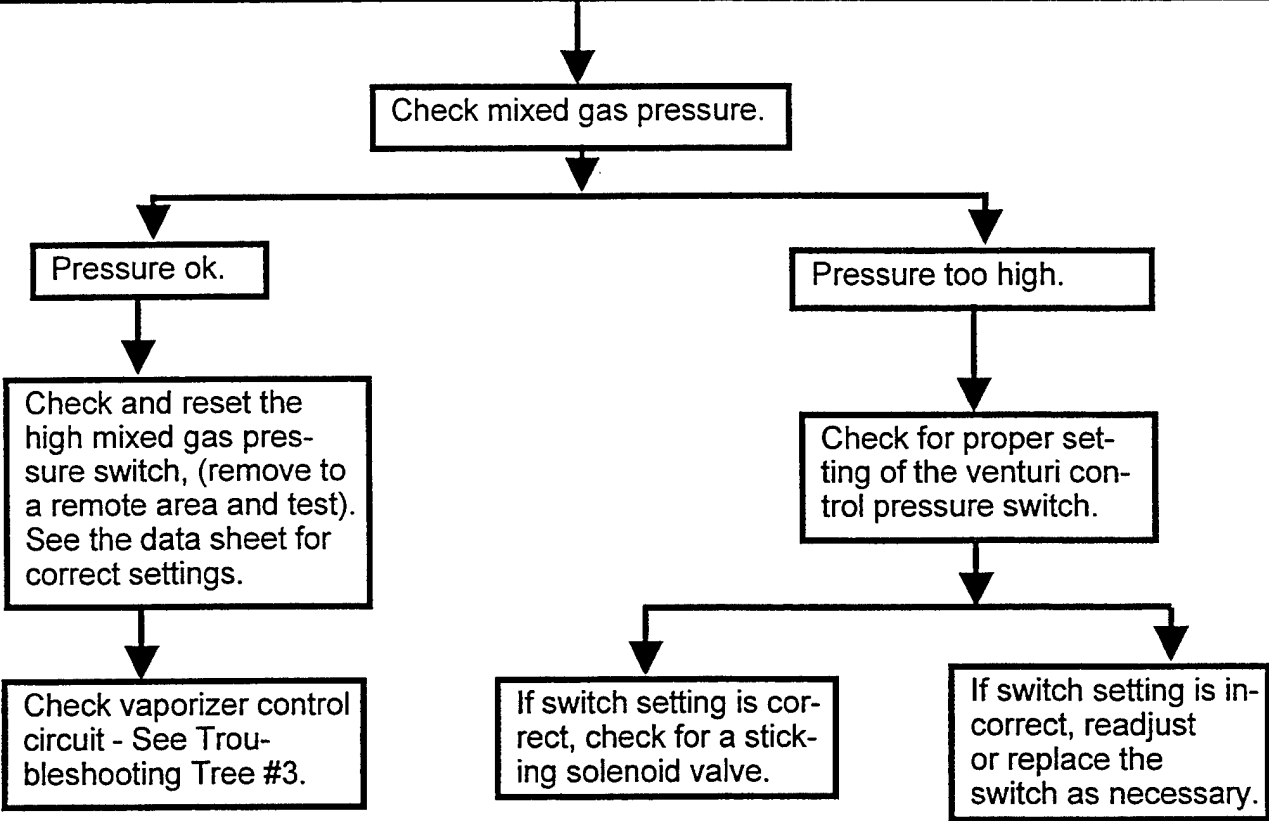

**TREE #6  
LPG LIQUID SOLENOID VALVE DOES NOT OPEN.**

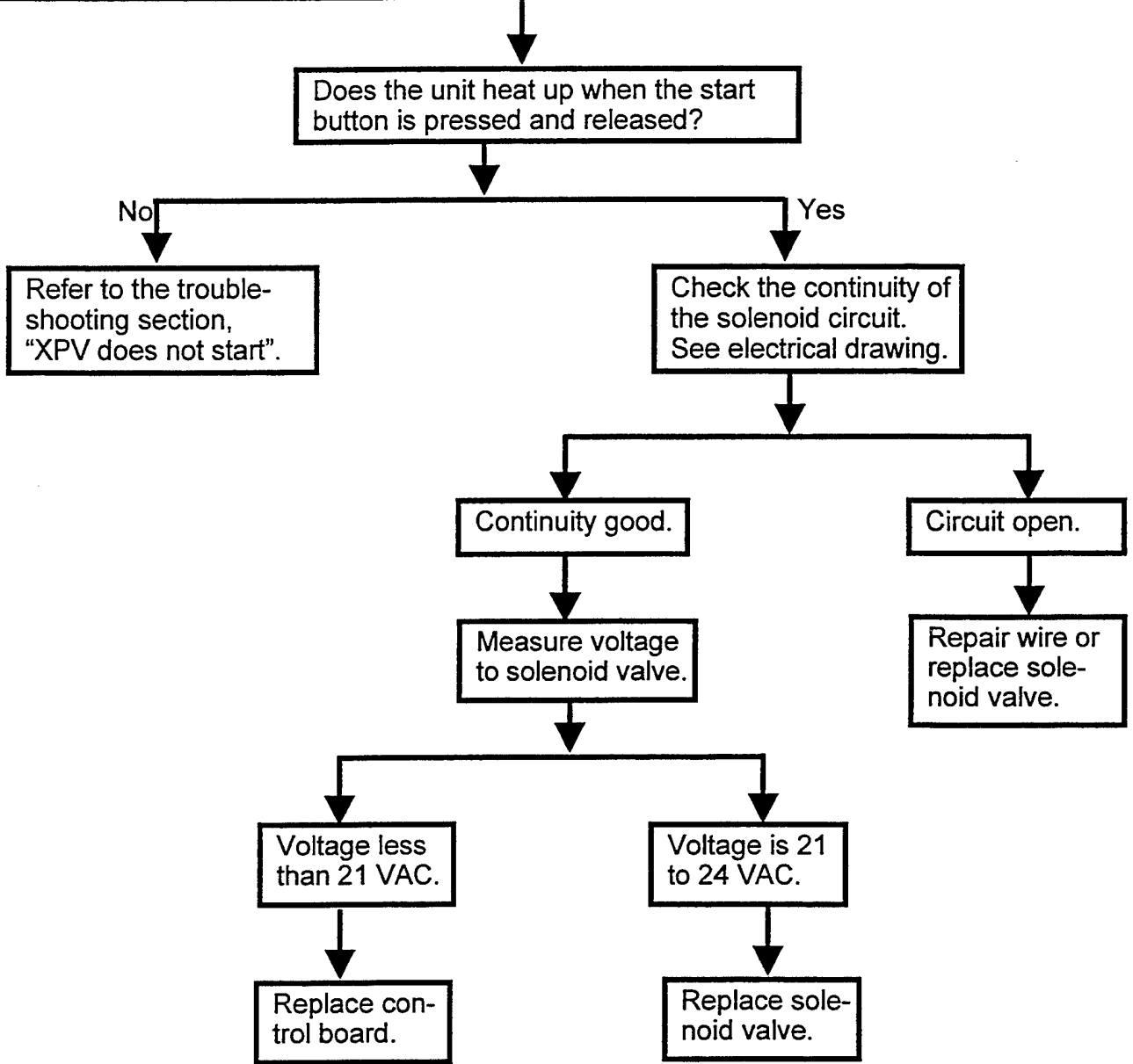

**TREE #7  
UNIT OPERATES BUT SHUTS OFF INTERMITTENTLY.**

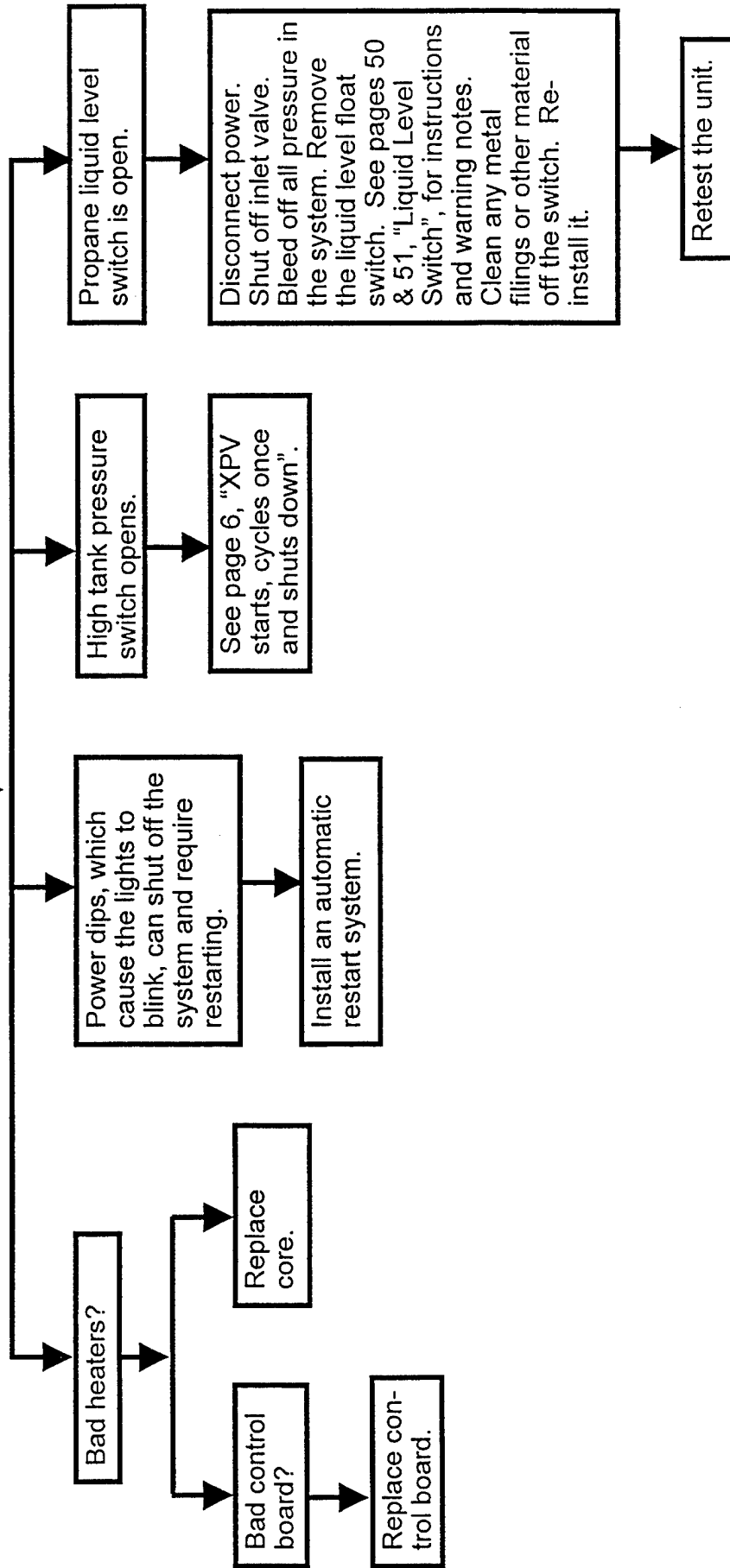

## TESTING INDIVIDUAL COMPONENTS

### 1. CONTACTORS

Checking the contactor:

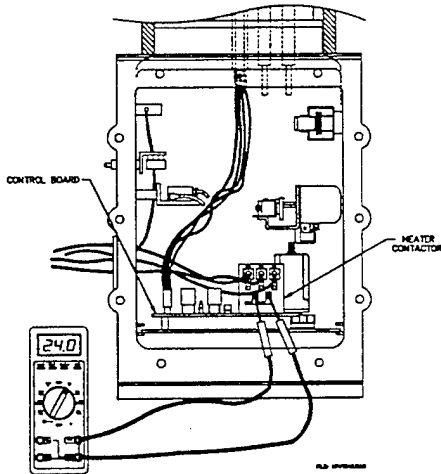

If the contactor is not closing:

Check the voltage across the contactor coil. The voltage should be 24 VAC. If the voltage is 24 VAC and the contactor is not closing, and therefore energizing the heaters, replace the contactor. If the voltage is 0 VAC, check the wiring from the contactor coil to the control board connections, E3 and E4. If the wiring is OK and the voltage across the coil and E3/E4 is 0 VAC, replace the control board.

### 2. HIGH TANK PRESSURE SAFETY SWITCH

Shuts off the unit when the mixed gas pressure is too high due to a malfunction in the control system. See data sheet for pressure setting. The pressure is adjusted by turning the adjustment dial on the switch.

Accuracy of the high tank pressure safety switch can be checked with an external regulator and calibrated pressure gauge or by removing the gauge and testing it with a known pressure.

*Switch?*

### 3. LOW VAPOR SAFETY SWITCH

Shuts off the unit if the vapor pressure is too low.

Accuracy of the low vapor safety switch can be checked with an external regulator and calibrated pressure gauge or by removing the gauge and testing it with a known pressure.

*Switch?*

## REPLACING XPV SYSTEMS COMPONENTS

### A. REPLACING THE CONTACTOR:

1. Turn off the power at the disconnect
2. Close the inlet isolation valve, bleed the system to 0 pressure.
3. Remove the front cover.
4. Remove the RTD and Main Molex connectors from the control board.
5. Slide out the control board.
6. Remove the top four or six power wires from the contactor line terminals.
7. Remove both quick disconnect coil wires.
8. Remove the holddown bolts of the contactor.
9. Install the new contactor.
10. Re-connect the coil wires and power wires.
11. Slide the control board back into the housing.
12. Reconnect the RTD and Main Molex connectors.
13. Replace the front cover.
14. Turn on power at the disconnect.
15. Restart the system.
16. Check operation, refer to the "Adjustment procedures for system operating controls."

**B. REPLACING THE MIXED GAS PRESSURE VENTURI CONTROL SWITCH:**

**NOTE:** See Adjustment Procedures for System Operating and Safety Controls: Mixed Gas Pressure Control Switch, earlier in this manual for additional information.

1. Turn off the power at the disconnect, close the inlet hand valve and bleed the system to 0 pressure.
2. Remove the wires to the switch.
3. Remove the switch with an open end wrench.
4. Install a new switch.
5. Turn power on, open isolation valve and bring system up to operating pressure.
6. Verify operation with external pressure gauges.
7. Refer to the adjustment procedures section for setting the switch.

**C. REPLACING THE HIGH TANK PRESSURE SAFETY SWITCH:**

1. Turn off the power at the disconnect, bleed the system to 0 pressure.
2. Remove the wires to the switch.
3. Remove the switch with an open end wrench.
4. Install a new switch.
5. Turn power on, open isolation valve, and bring system up to operating pressure.
6. Check carefully for leaks at all connections.
7. Refer to the adjustment procedures section for setting the switch.

**D. REPLACING THE LOW VAPOR SAFETY SWITCH:**

1. Turn off the power at the disconnect, bleed the system to 0 pressure.
2. To replace the low vapor safety switch, the Mixed Gas Operating Pressure Control Switch and the High Tank Pressure Switch must be removed.
3. Remove the wires to the switch.
4. Remove the switch with an open end wrench.
5. Install a new switch.
6. Replace the Mixed Gas Operating Pressure Control Switch and the High Tank Pressure Switch.
7. Turn power on, open isolation valve and bring system up to operating pressure.
8. Refer to the adjustment procedures section for setting the switch.

**E. TIME DELAY RELAY**



**WARNING: Turn power off at the disconnect before servicing!**

The time delay relay is used to allow the vaporizer sufficient time for the vapor pressure switch to be satisfied before opening the venturi. It should be set for five seconds. The correct dip switch settings are shown on the electrical schematic in this manual.

The time delay relay simply plugs in a multi-pin socket. To remove it, rock back and forth gently to loosen it and pull it up. The plastic aligning pin is notched for correct alignment.

**F. REPLACING THE LIQUID LEVEL SWITCH:**

See page 20.

## VAPORIZER OPERATION

The POWER XP Series Electric Vaporizer utilizes a finned, cast aluminum heater core. The heater core contains multiple cast-in resistance heater elements. Multiple wiring configurations allow a variety of AC input voltages to suit local power supply requirements.

Liquid LPG enters the vaporizer through an inlet safety solenoid valve at the base of the pressure vessel.

The solenoid is a normally closed valve. It opens at a preset temperature after initial start-up, and remains open under normal operation. Violation of either the high temperature safety or the liquid level float switch cause the solenoid to de-energize (close).

During operation, an RTD temperature sensor and solid state control system maintain the core temperature at approximately 195° F. Liquid LPG enters the vaporizer and comes in contact with the heater core. Vaporization results as the liquid LPG extracts energy (heat) from the heater core. As the heater core cools, the RTD provides a signal to the control system to energize the heater power contactor, applying power to the heater elements. The control board also provides the logic to shut off the vaporizer in the event of a safety circuit violation.

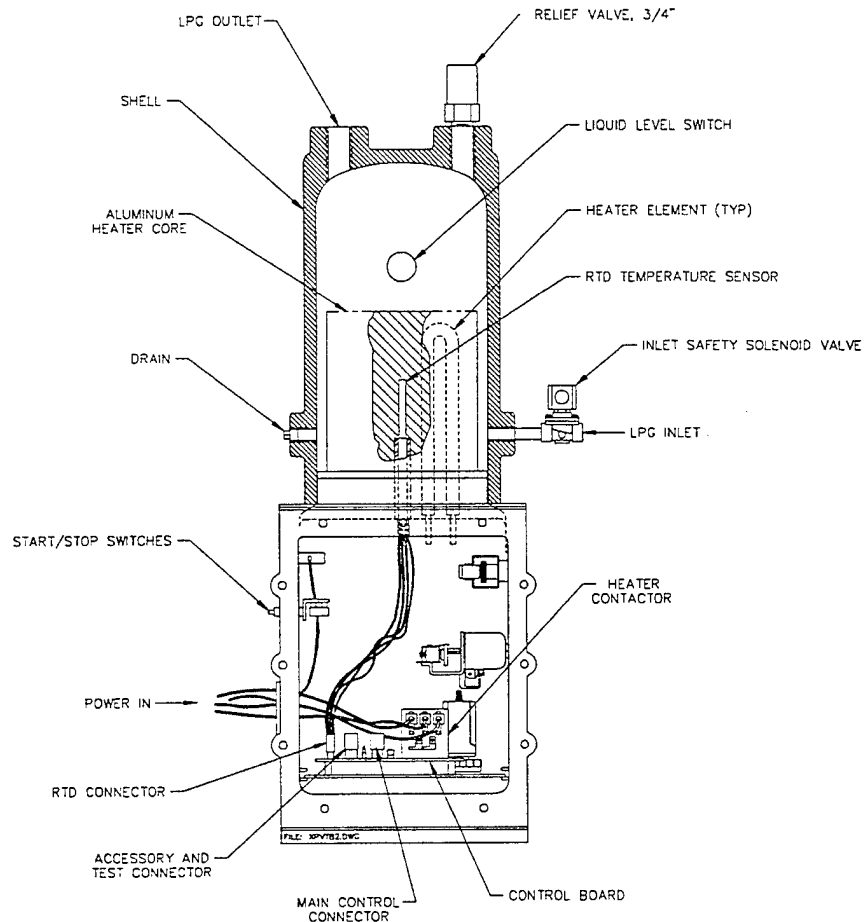

## FULL LOAD VOLTAGE CHECK

Current flow depends on the applied voltage. Voltage lower than the specified voltage causes low current. Make all measurements with the heater **ON** (contactor closed).



### **WARNING:**

**THESE TESTS INCLUDE HIGH VOLTAGE. EXERCISE GREAT CAUTION IN MAKING THESE FOLLOWING TESTS. CARELESSNESS COULD RESULT IN SEVERE INJURY OR DEATH.**

## FULL LOAD VOLTAGE CHECK

Check heater voltage by measuring voltage at the contactor terminals. Check the Data Sheet in Appendix C of your manual or the data tag on the vaporizer to determine the correct voltage reading for your vaporizer. Measure voltage between all connected poles of the relay. The readings should be equal to  $\pm 3\%$ .

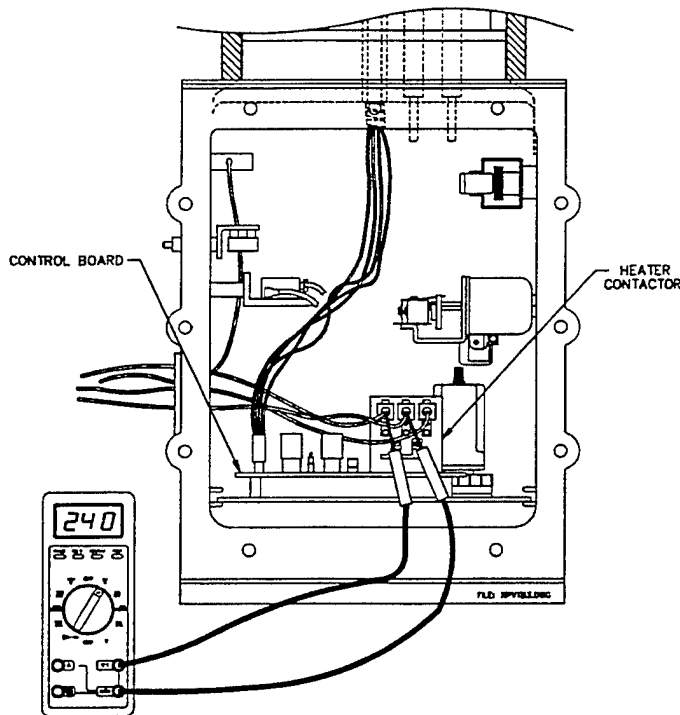

### **NOTE:**

**Low voltage reduces the vaporization capacity of your vaporizer.**

## VAPORIZER OPERATION

The POWER XP Series Electric Vaporizer utilizes a finned, cast aluminum heater core. The heater core contains multiple cast-in resistance heater elements. Multiple wiring configurations allow a variety of AC input voltages to suit local power supply requirements.

Liquid LPG enters the vaporizer through an inlet safety solenoid valve at the base of the pressure vessel. The solenoid is a normally closed valve. It opens at a preset temperature after initial start-up, and remains open under normal operation. Violation of either the high temperature safety or the liquid level float switch cause the solenoid to de-energize (close).

During operation, an RTD temperature sensor and solid state control system maintain the core temperature at approximately 195° F. Liquid LPG enters the vaporizer and comes in contact with the heater core. Vaporization results as the liquid LPG extracts energy (heat) from the heater core. As the heater core cools, the RTD provides a signal to the control system to energize the heater power contactor, applying power to the heater elements. The control board also provides the logic to shut off the vaporizer in the event of a safety circuit violation.

## FULL LOAD CURRENT CHECK

Measure the current on each of the heater AC power input wires. Check the Data Sheet in Appendix C of your manual for the correct reading (line current) for your vaporizer. All wires should have equal readings of +/-3%.

Low current on all wires indicates low input voltage. Drastically different current readings indicate a defective heater, defective wiring or an open fusible link (if incorporated) due to overheating. If a fusible link is open, contact the factory. Do not attempt to repair. See Heater Resistance Check for more information.



### **WARNING:**

**THESE TESTS INCLUDE HIGH VOLTAGE. EXERCISE GREAT CAUTION IN MAKING THE FOLLOWING TESTS. CARELESSNESS COULD RESULT IN SEVERE INJURY OR DEATH. (See additional warnings on page 1 of Appendix A.)**

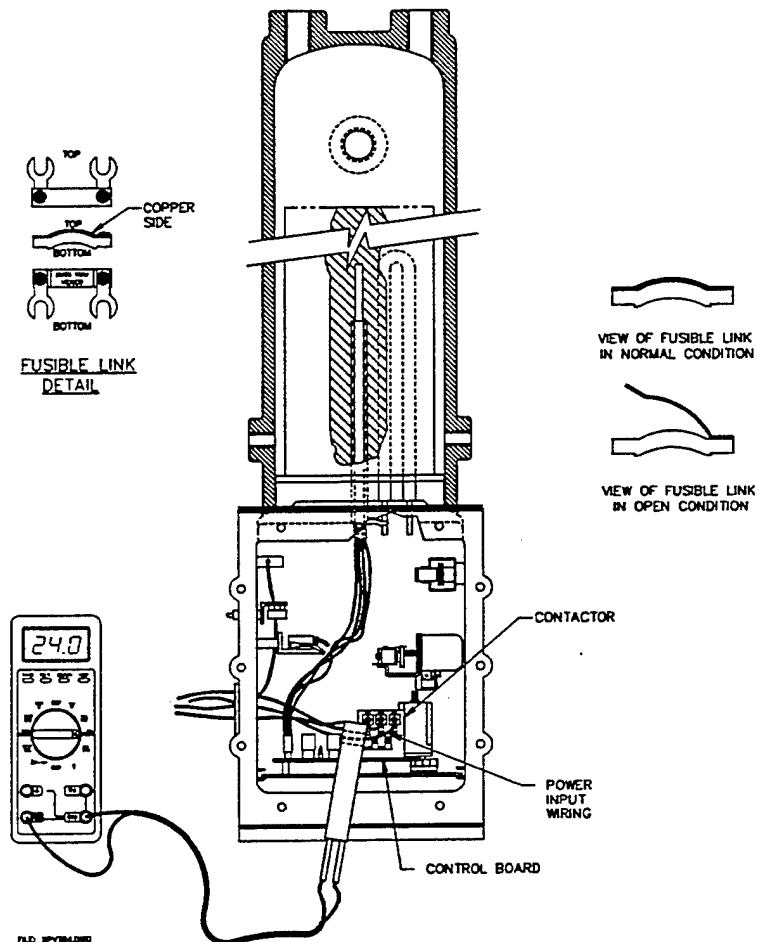

## HEATER CORE RESISTANCE



**CAUTION:**

Turn off electrical power at the disconnect before proceeding.

Remove the two molex plugs (MAIN and RTD) from the control board. Slide out the control board to obtain access to the heater wire connections on the contactor. Measure the resistance across each pair of wires. Refer to the wiring diagram in your manual for resistance data. An incorrect resistance reading indicates either a faulty heater element, a wiring problem, or an open fusible link (if incorporated).

READS WIRE TO WIRE  
RESISTANCE.  
SEE SPEC SHEET FOR  
YOUR VAPORIZER

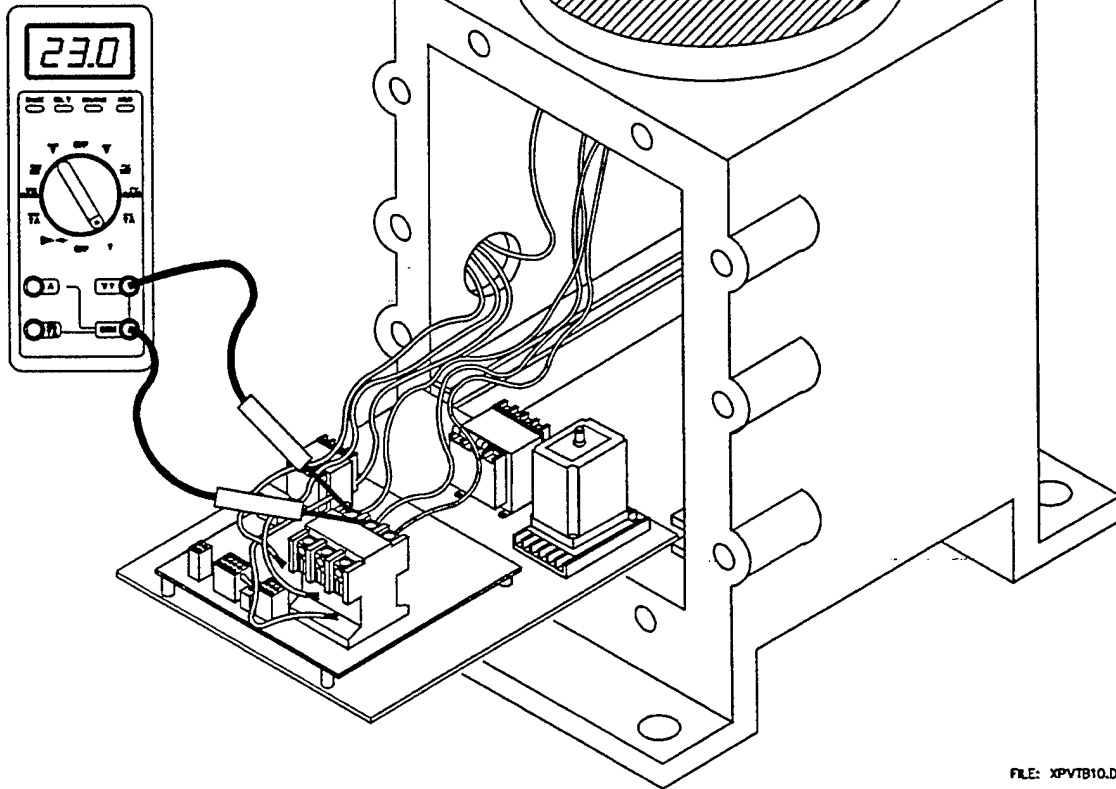

FILE: XPVTB10.DWG

## LIQUID LEVEL SAFETY SWITCH



**CAUTION:** Turn off power at the disconnect.

Open the control box housing and disconnect the "MAIN" connector on the front of the control board. Check for continuity between pins 5 & 6 as shown below. If your meter reads 0 ohms, the float switch is good. Close the control box. Turn power on at the disconnect. Start vaporizer again.

If the switch reads open (OL on the meter), do the following tests: Remove the conduit elbow cover at the liquid level switch. Disconnect and separate the four wires and test as shown below. A reading other than what is indicated shows a bad liquid level switch. Replace it. If the liquid level switch is good, repair the wiring between the liquid level switch and the control board.

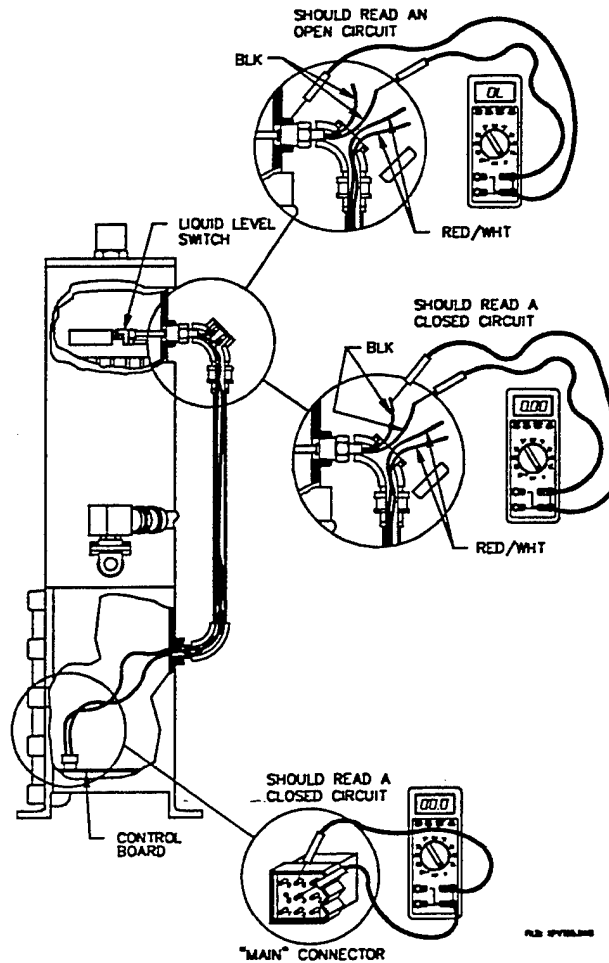

## REPLACING THE LIQUID LEVEL SWITCH



**CAUTION:** Turn power off at the disconnect.



**CAUTION:** Close the liquid LPG inlet hand valve, bleed off all of the pressure in the vaporizer before proceeding.

- Step 1: Remove the conduit elbow cover (1).
- Step 2: Pull out and separate the wires (2).
- Step 3: Disconnect the conduit union (3).
- Step 4: Unscrew the conduit elbow from the liquid level safety switch (4).
- Step 5: Remove the liquid level safety switch (5). The arrow scribe on the float switch must be up in order to pull the float back through the mounting hole. See below.

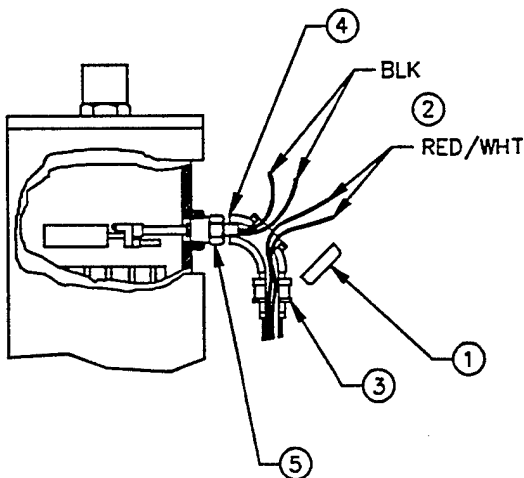

SCRIBE MARK SHOWS UP POSITION OF FLOAT SWITCH



CORRECT: FLOAT SWITCH WITH MARK IN UP POSITION

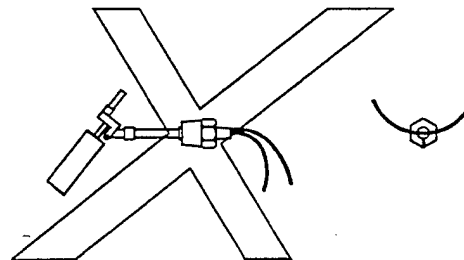

WRONG: FLOAT SWITCH WITH MARK IN DOWN POSITION

**NOTE:** Use a teflon base thread compound to seal for leaks when re-installing the float switch.

## SOLENOID VALVE LEAK TEST

1. Shut off the outlet hand valve. The inlet hand valve should be open. Start the vaporizer and allow it to heat up until the heaters shut off. This allows any accumulated liquid in the vaporizer to be forced back toward the supply tank.
2. Turn off the vaporizer. Shut off the power at the disconnect. Shut off the inlet hand valve. Close ball valve on vaporizer pressure gauge and remove the pressure gauge. Cautiously bleed off any LPG pressure in the vaporizer and outlet supply piping. When the pressure reaches no pressure in the vaporizer, reinstall the pressure gauge and verify 0 pressure.
3. Turn on the inlet hand valve. The solenoid valve is closed and you should not have any pressure build up in the vaporizer. If pressure increases, the solenoid valve is leaking and needs to be repaired or replaced. If it is not leaking in this condition, turn the power back on at the disconnect. Do not turn on the vaporizer power switch.
4. Check again for a leaking solenoid valve. The pressure should remain at zero. If the pressure does not remain at zero, change the diaphragm.

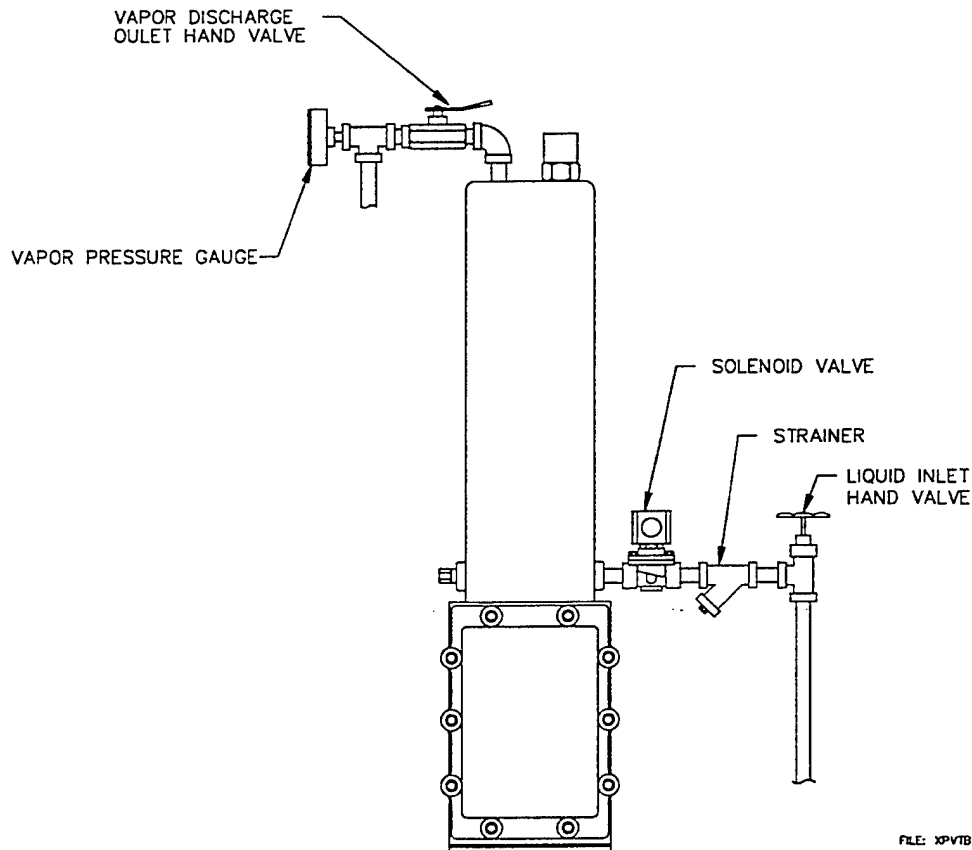

FILE: XPVTB7.DWG

## SOLENOID VALVE ELECTRICAL TEST



### WARNING:

SHUT OFF POWER AT THE ELECTRICAL DISCONNECT BEFORE PROCEEDING.

Open the electrical housing at the vaporizer base. Disconnect the "MAIN" (JP1) connector and measure resistance between pins 6 & 7 on the molex plug connector. You should measure approximately 3 ohms. If not, remove the cover at the conduit elbow, disconnect the wires and measure the solenoid leads again. If the measured resistance is still incorrect, change the **solenoid coil**. If it is good, repair the wiring between the elbow and the control board.

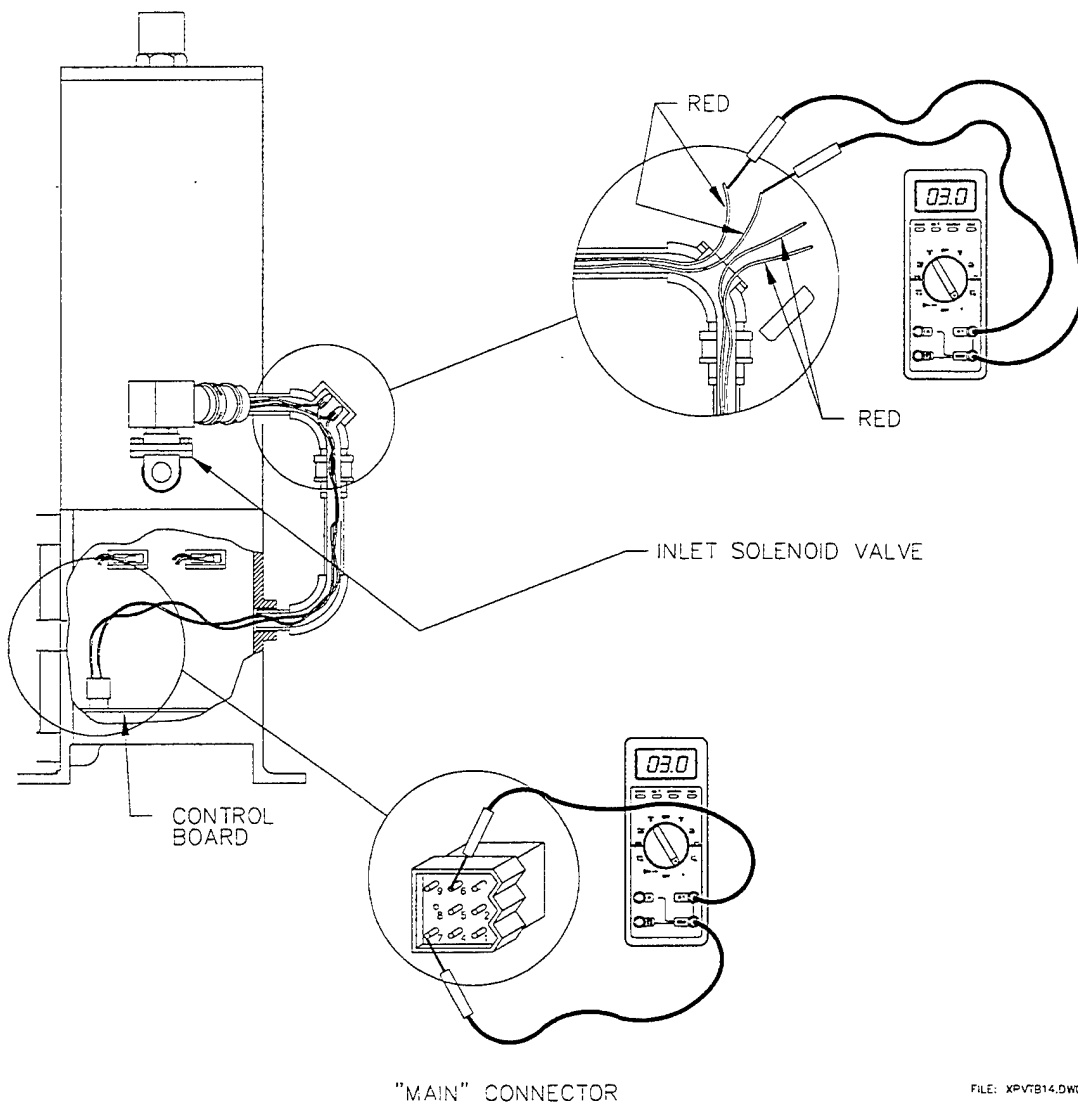

FILE: XPVTB14.DWG

## RTD TEMPERATURE SENSOR

RTD resistance varies according to temperature. Consult the Temperature vs. Resistance tables on the following pages.

**NOTE:** RTD #1 is pins 1 & 2 (High Temp. Limit and Solenoid)  
RTD #2 is pins 3 & 4 (High Temp. Limit & Heater Control)

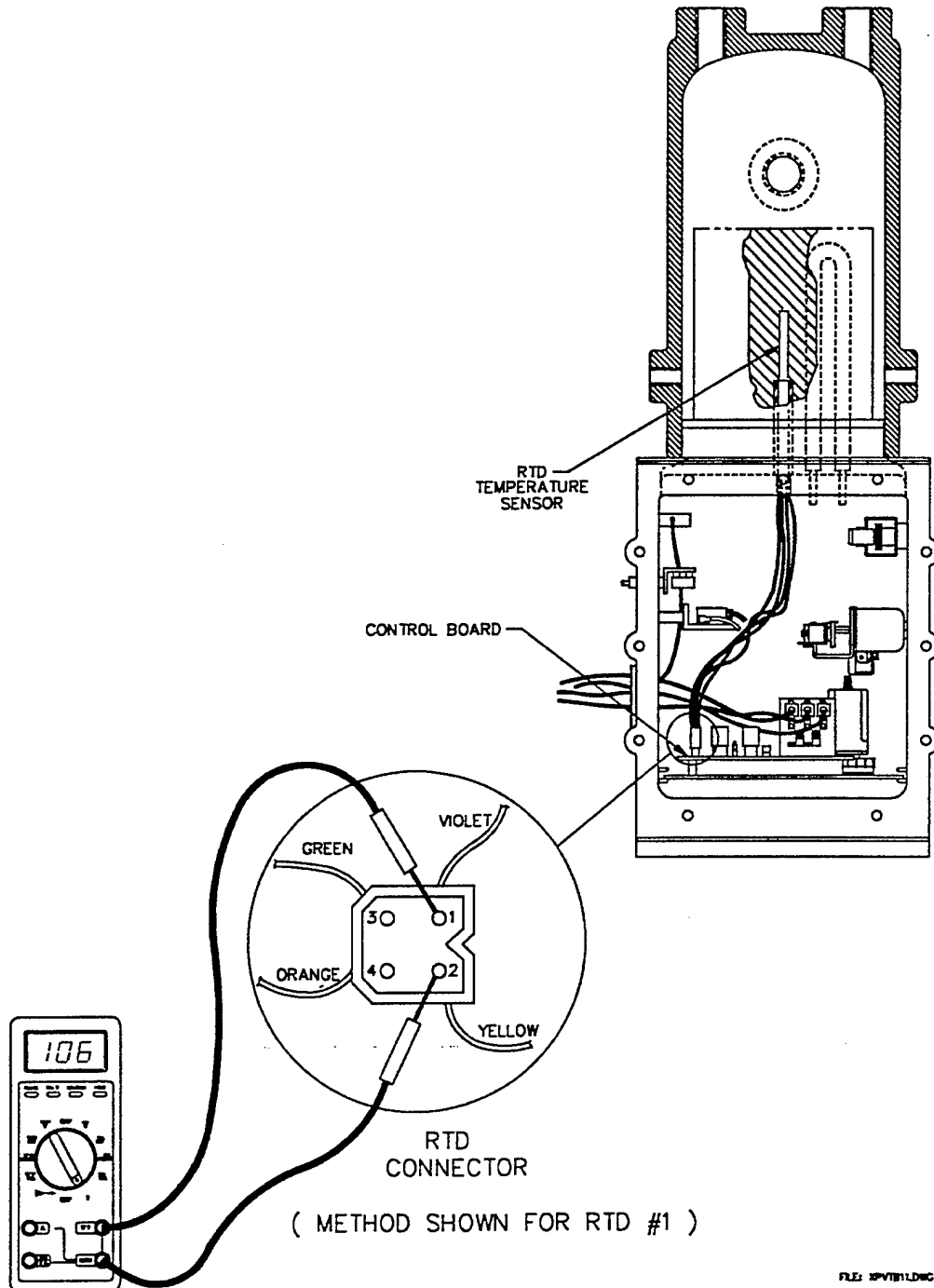

**TEMPERATURE vs. RESISTANCE TABLE - Centigrade**

**Platinum 100Ω at 0° C. 0.00385 Ω/Ω° C.**

T (°C)	R (Ω)	T (°C)	R (Ω)	T (°C)	R (Ω)	T (°C)	R (Ω)
0.0	100.000	50.0	119.395	100.0	138.500	150.0	157.315
1.0	100.391	51.0	120.780	101.0	138.879	151.0	157.668
2.0	100.781	52.0	120.165	102.0	139.258	152.0	158.061
3.0	101.172	53.0	120.549	103.0	139.637	153.0	158.434
4.0	101.562	54.0	120.943	104.0	140.016	154.0	158.807
5.0	101.953	55.0	121.318	105.0	140.394	155.0	159.180
6.0	102.343	56.0	121.703	106.0	140.773	156.0	159.553
7.0	102.733	57.0	122.087	107.0	141.151	157.0	159.925
8.0	103.123	58.0	122.471	108.0	141.530	158.0	160.298
9.0	103.513	59.0	122.855	109.0	141.908	159.0	160.670
10.0	103.902	60.0	123.239	110.0	142.286	160.0	161.043
11.0	104.292	61.0	123.623	111.0	142.664	161.0	161.415
12.0	104.681	62.0	124.007	112.0	143.042	162.0	161.787
13.0	105.071	63.0	124.390	113.0	143.420	163.0	162.159
14.0	105.460	64.0	124.774	114.0	143.797	164.0	162.531
15.0	105.849	65.0	125.157	115.0	144.175	165.0	162.902
16.0	106.238	66.0	125.540	116.0	144.552	166.0	163.274
17.0	106.627	67.0	125.923	117.0	144.929	167.0	163.646
18.0	107.016	68.0	126.306	118.0	145.307	168.0	164.017
19.0	107.404	69.0	126.689	119.0	145.684	169.0	164.388
20.0	107.793	70.0	127.072	120.0	146.061	170.0	164.759
21.0	108.181	71.0	127.454	121.0	146.437	171.0	165.130
22.0	108.570	72.0	127.837	122.0	146.814	172.0	165.501
23.0	108.958	73.0	128.219	123.0	147.191	173.0	165.872
24.0	109.346	74.0	128.601	124.0	147.567	174.0	166.243
25.0	109.734	75.0	128.984	125.0	147.943	175.0	166.613
26.0	110.122	76.0	129.366	126.0	148.320	176.0	166.984
27.0	110.509	77.0	129.748	127.0	148.696	177.0	167.354
28.0	110.897	78.0	130.129	128.0	149.072	178.0	167.724
29.0	111.284	79.0	130.511	129.0	149.448	179.0	168.094
30.0	111.672	80.0	130.893	130.0	149.823	180.0	168.464
31.0	112.059	81.0	131.274	131.0	150.199	181.0	168.834
32.0	112.446	82.0	131.655	132.0	150.575	182.0	169.204
33.0	112.833	83.0	132.037	133.0	150.950	183.0	169.573
34.0	113.220	84.0	132.418	134.0	151.325	184.0	169.943
35.0	113.607	85.0	132.799	135.0	151.701	185.0	170.312
36.0	113.994	86.0	133.180	136.0	152.076	186.0	170.682
37.0	114.380	87.0	133.560	137.0	152.451	187.0	171.051
38.0	114.767	88.0	133.941	138.0	152.825	188.0	171.420
39.0	115.153	89.0	134.322	139.0	153.200	189.0	171.789
40.0	115.539	90.0	134.702	140.0	153.575	190.0	172.158
41.0	115.925	91.0	135.082	141.0	153.949	191.0	172.526
42.0	116.311	92.0	135.463	142.0	154.324	192.0	172.895
43.0	116.697	93.0	135.843	143.0	154.698	193.0	173.263
44.0	117.083	94.0	136.223	144.0	155.072	194.0	173.632
45.0	117.469	95.0	136.602	145.0	155.446	195.0	174.000
46.0	117.854	96.0	136.982	146.0	155.820	196.0	174.368
47.0	118.239	97.0	137.362	147.0	156.194	197.0	174.736
48.0	118.625	98.0	137.741	148.0	156.568	198.0	175.104
49.0	119.010	99.0	138.121	149.0	156.941	199.0	175.472

**TEMPERATURE vs. RESISTANCE TABLE - Fahrenheit**

**Platinum 100Ω at 0° F. 0.00385 Ω/Ω° C.**

T (°F)	R (Ω)	T (°F)	R (Ω)	T (°F)	R (Ω)	T (°F)	R (Ω)
32.0	100.000	82.0	110.811	132.0	121.532	182.0	132.164
33.0	100.217	83.0	111.026	133.0	121.746	183.0	132.375
34.0	100.434	84.0	111.241	134.0	121.959	184.0	132.587
35.0	100.651	85.0	111.457	135.0	122.172	185.0	132.799
36.0	100.868	86.0	111.672	136.0	122.386	186.0	133.010
37.0	101.085	87.0	111.887	137.0	122.599	187.0	133.222
38.0	101.302	88.0	112.102	138.0	122.813	188.0	133.434
39.0	101.519	89.0	112.317	139.0	123.026	189.0	133.645
40.0	101.736	90.0	112.532	140.0	123.239	190.0	133.857
41.0	101.953	91.0	112.747	141.0	123.452	191.0	134.068
42.0	102.169	92.0	112.962	142.0	123.666	192.0	134.279
43.0	102.386	93.0	113.177	143.0	123.879	193.0	134.491
44.0	102.603	94.0	113.392	144.0	124.092	194.0	134.702
45.0	102.819	95.0	113.607	145.0	124.305	195.0	134.913
46.0	103.036	96.0	113.822	146.0	124.518	196.0	135.125
47.0	103.253	97.0	114.037	147.0	124.731	197.0	135.336
48.0	103.469	98.0	114.251	148.0	124.944	198.0	135.547
49.0	103.686	99.0	114.466	149.0	125.157	199.0	135.758
50.0	103.902	100.0	114.681	150.0	125.370	200.0	135.969
51.0	104.119	101.0	114.895	151.0	125.583	201.0	136.180
52.0	104.335	102.0	115.110	152.0	125.795	202.0	136.391
53.0	104.551	103.0	115.325	153.0	126.008	203.0	136.602
54.0	104.768	104.0	115.539	154.0	126.221	204.0	136.813
55.0	104.984	105.0	115.754	155.0	126.434	205.0	137.024
56.0	105.200	106.0	115.968	156.0	126.646	206.0	137.235
57.0	105.417	107.0	116.183	157.0	126.859	207.0	137.446
58.0	105.633	108.0	116.397	158.0	127.072	208.0	137.657
59.0	105.849	109.0	116.611	159.0	127.284	209.0	137.868
60.0	106.065	110.0	116.826	160.0	127.497	210.0	138.078
61.0	106.281	111.0	117.040	161.0	127.709	211.0	138.289
62.0	106.497	112.0	117.254	162.0	127.922	212.0	138.500
63.0	106.713	113.0	117.469	163.0	128.134	213.0	138.710
64.0	106.929	114.0	117.683	164.0	128.347	214.0	138.921
65.0	107.145	115.0	117.897	165.0	128.559	215.0	139.132
66.0	107.361	116.0	118.111	166.0	128.771	216.0	139.342
67.0	107.577	117.0	118.325	167.0	128.984	217.0	139.553
68.0	107.793	118.0	118.539	168.0	129.196	218.0	139.763
69.0	108.009	119.0	118.753	169.0	129.408	219.0	139.974
70.0	108.224	120.0	118.967	170.0	129.620	220.0	140.184
71.0	108.440	121.0	119.181	171.0	129.832	221.0	140.394
72.0	108.656	122.0	119.395	172.0	130.045	222.0	140.605
73.0	108.871	123.0	119.609	173.0	130.257	223.0	140.815
74.0	109.087	124.0	119.823	174.0	130.469	224.0	141.025
75.0	109.303	125.0	120.036	175.0	130.681	225.0	141.235
76.0	109.518	126.0	120.250	176.0	130.893	226.0	141.446
77.0	109.734	127.0	120.464	177.0	131.105	227.0	141.656
78.0	109.949	128.0	120.678	178.0	131.317	228.0	141.866
79.0	110.165	129.0	120.891	179.0	131.528	229.0	142.076
80.0	110.380	130.0	121.105	180.0	131.740	230.0	142.286
81.0	110.595	131.0	121.318	181.0	131.952	231.0	142.496

# *APPENDIX A*

*PARTS INFORMATION*

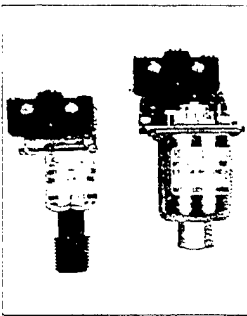

## 54 Series Pressure Switches

### Types

Enclosed: J54, J54A, H54,  
Skeleton: J54S, J54AS, H54S,



UNITED ELECTRIC  
CONTROLS

## Installation and Maintenance Instructions

Please read all instructional literature carefully and thoroughly before starting. Refer to the final page for the listing of Recommended Practices, Liabilities and Warrantees.

### GENERAL

As the pressure changes, a diaphragm, bellows or piston sensor actuates one or two snap acting switches. The 54 Series offers two types of adjustments: internal hex adjustment on the "J" types or a calibrated adjustment dial on "H" types.

## Part I - Installation

#### Tools Needed

Flatblade screwdriver  
Adjustable wrench to 1 1/8"

### MOUNTING

LOCATE SWITCH WHERE VIBRATION, SHOCK, AND AMBIENT TEMPERATURE FLUCTUATIONS ARE MINIMAL. TO AVOID DAMAGE TO CONTROL, ALWAYS HOLD THE WRENCH ON THE WRENCH FLATS OR HEX PORTION OF THE PRESSURE CONNECTION WHEN TIGHTENING.

The control can be mounted in any position.

#### Enclosed Versions J54, J54A and H54

Remove cover first by removing the one captive screw located on the front of the cover.

#### Pipe Mounting

Mount the control directly to the line via the NPT pressure connection.

#### Vertical Surface Mount

Two holes for #10 screws are provided in the bracket plate.

#### Conduit Connection

A 7/8" diameter hole has been provided in the bracket plate for mounting a 1/2" NPT conduit fitting.

#### Skeleton Versions J54S, J54AS H54S

#### Pipe Mounting

Mount the control directly to the line via the NPT pressure connection.

#### Vertical Surface Mount

Two openings for #6 screws are provided in the rear of the bracket plate.

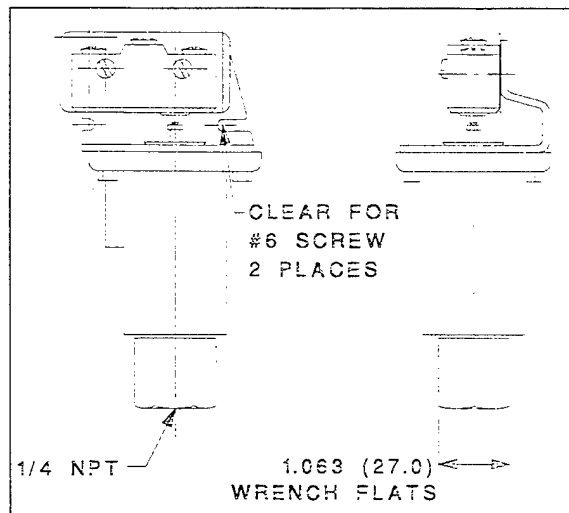

Mounting for skeleton versions (J54S shown)

### WIRING

ALL LIVE SUPPLY CIRCUITS MUST BE DISCONNECTED BEFORE WIRING THE CONTROL. WIRE IN ACCORDANCE WITH NATIONAL AND LOCAL WIRING CODES. MAXIMUM RECOMMENDED WIRE SIZE IS #14AWG.

Bring wires up to the terminals from the rear, so that wires lay along insulator.

## Part II - Adjustments

#### Tools Needed

1/4" open end wrench  
Flatblade screwdriver

# Dimensions

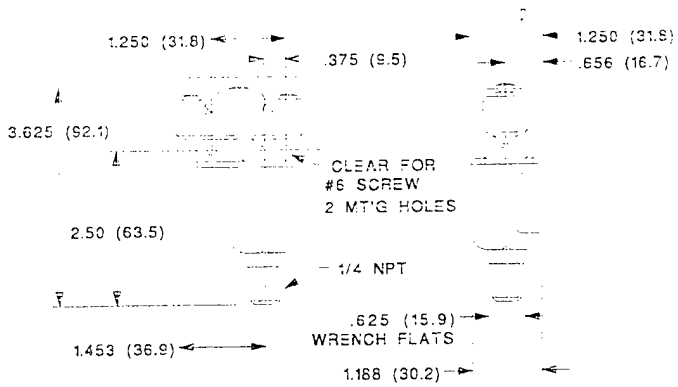

**Type J54S models 22 - 28**

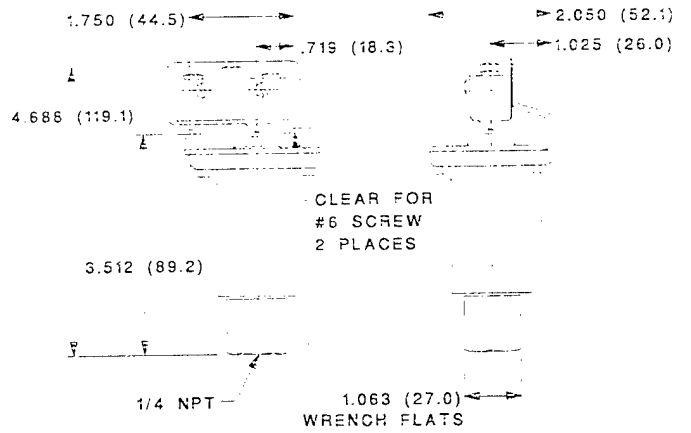

**Type J54S models 610 - 614**

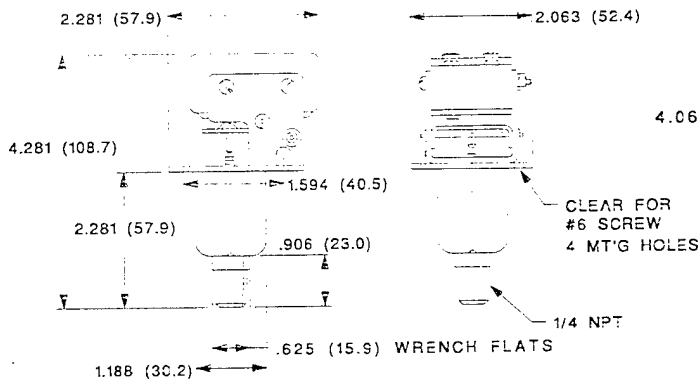

**Type J54AS models 22 - 28**

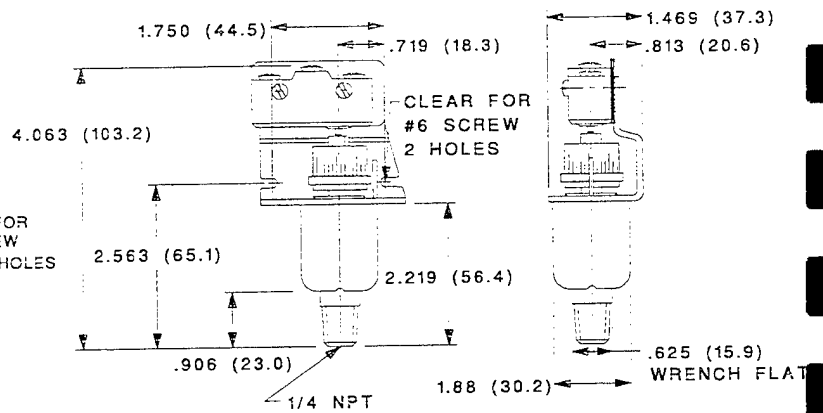

**Type H54S models 22 - 28**

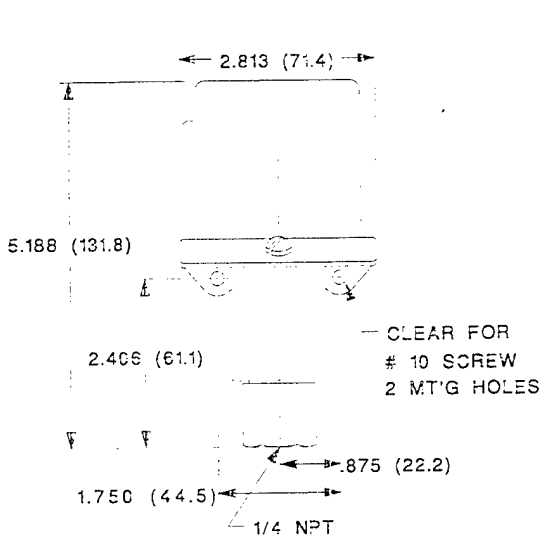

**Type J54 models 610 - 614**

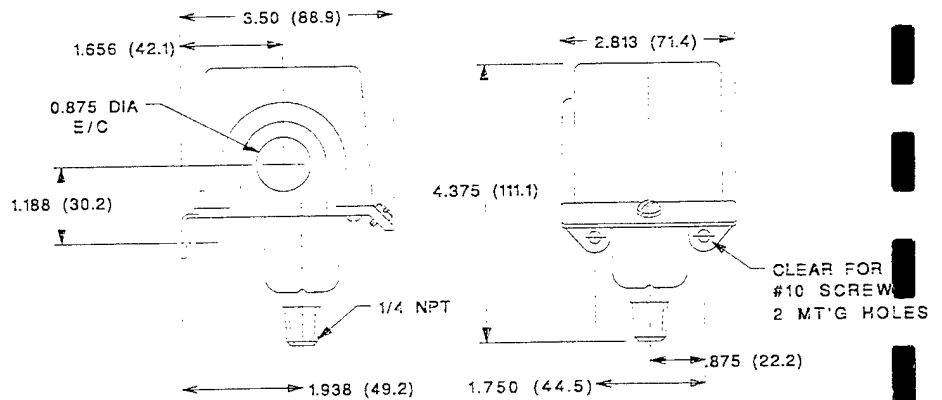

**Type H54, J54 and J54A models 22 - 28**

### Uncalibrated Single Switch Versions J54, J54S

Mount control onto a calibrated pressure source (vacuum source for model 22). Secure. Use pipe sealant or teflon tape to ensure tight vacuum seal.

 USING THE SENSOR HOUSING OR BRACKET TO TIGHTEN THE FITTING TO THE SOURCE WILL RESULT IN DAMAGE TO THE CONTROL.

Using a 1/4" open end wrench, turn main adjustment screw counterclockwise (out of sensor plunger) to lower set point or clockwise (into sensor plunger) to raise set point.

 ALWAYS RECHECK SET POINTS AFTER ANY ADJUSTMENTS ARE MADE.

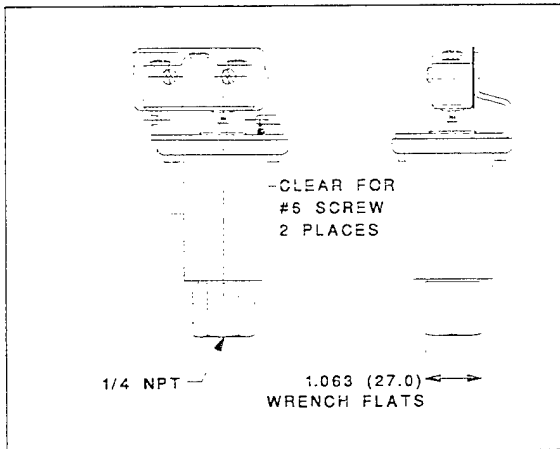

Type J54S, models 610-614

### Calibrating Single Switch Versions H54, H54S

Turn the calibrated reference dial to desired set point by aligning setting on dial with dowel pin.

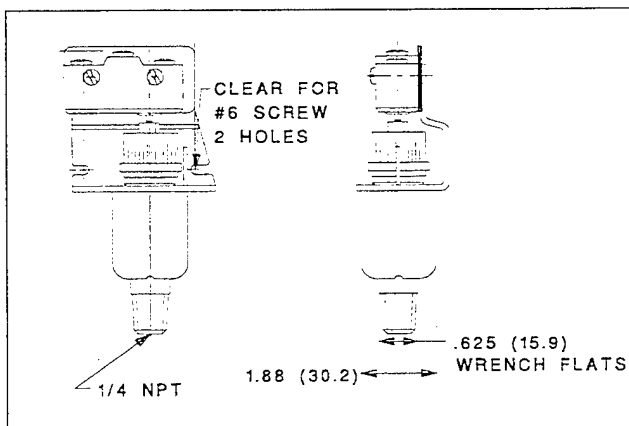

Type H54S, models 22-28

### Calibrating All Dual Switch Versions J54A, J54AS

Mount control via an NPT pressure connection onto a calibrated pressure source (vacuum source for model 22). Secure fitting to source tight enough to prevent leaks. Use teflon tape to secure firmly. Apply tightening torque to the fitting only.

 USING THE SENSOR HOUSING OR BRACKET TO TIGHTEN THE FITTING TO THE SOURCE WILL RESULT IN DAMAGE TO THE CONTROL.

#### High Set of Range

Using a 1/4" open end wrench, turn main adjustment screw counterclockwise (out of sensor plunger) to lower set point or clockwise (into sensor plunger) to raise set point. Turning the 1/4" hex screw clockwise until "high set" switch transfers at the target pressure point provides a pressure rise set point.

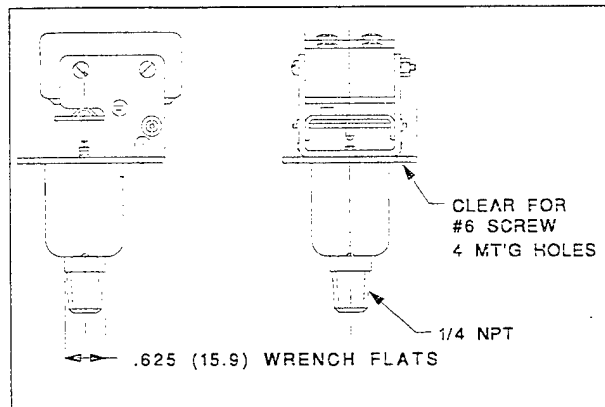

Type J54AS, models 22-28

#### Low Set of Range

Using a 1/4" open end wrench, turn "low set" microswitch screw counterclockwise (out of sensor plunger) to lower set point or clockwise (into sensor plunger) to raise set point. Turn screw until both "high set" and "low set" switches transfer together on or near the target pressure on rise.

Turn the "low set" switch adjustment screw clockwise (into sensor plunger) until the "low set" switch transfers at the desired pressure on fall (unless required otherwise).

Raise the pressure source to the "high set" pressure valve to check the set point pressure. Adjust the 1/4" hex screw accordingly if further fine adjustments are needed. Lower pressure to check the set point of the "low set". Fine adjust if necessary.

 ALWAYS RECHECK SET POINTS AFTER ANY ADJUSTMENTS ARE MADE.

### Manual Reset. Option 1530 or suffix "G"

A snap-acting switch with this option will remain tripped until pressure changes and the reset button is manually depressed, which resets the switch.

## Part III - Replacements

### Tools Needed

Flatblade screwdriver



**DISCONNECT ALL LIVE ELECTRICAL SUPPLY TO THE CONTROL BEFORE PERFORMING ANY DISASSEMBLY.**

Remove the cover if an enclosed type. Disconnect wires from switch terminals. Label each wire to ensure proper reconnections. Remove the two hex nuts and pull out the long screws. Remove the switch(es) and insulators. Note the position of switch plunger relative to sensor plunger or lever of dual switch.

Replace the old switch(es) with new ones, making sure that the switch plunger(s) is aligned with the sensor plunger, and the insulators are located between the switch(es) and bracket plate.

Align switch(es) and insulators with bracket plate. Install screws with hex nuts and tighten securely.



**DO NOT OVERTIGHTEN THE HEX NUTS OR SWITCH ACTUATION WILL BE AFFECTED. RECONNECT THE WIRES.**

The sensor assembly is not field replaceable. Do not attempt any disassembly of these parts. If any questions, consult the UE factory.

### **RECOMMENDED PRACTICES**

United Electric Controls Company recommends careful consideration of the following factors when specifying and installing UE pressure and temperature units. Before installing a unit, the Installation and Maintenance instructions provided with unit must be read and understood.

- To avoid damaging unit, proof pressure and max temperature limits stated in literature and on nameplates must never be exceeded, even by surges in the system. Operation of the unit up to proof pressure or max temperature is acceptable on a limited basis (i.e. start-up, testing) but continuous operation must be restricted to the designated adjustable range. Excessive cycling at proof pressure or maximum temperature limits could reduce sensor life.

- A back-up unit is necessary for applications where damage to the primary unit could endanger life, limb or property. A high or low limit switch is necessary for applications where dangerous runaway condition could result.

- The adjustable range must be selected so that incorrect, inadvertent or malicious setting at any range point can not result in an unsafe system condition.

- Install unit where shock, vibration and ambient temperature fluctuations will not damage unit or affect operation. Orient unit so that moisture does not enter the enclosure via the electrical connection.

- Unit must not be altered or modified after shipment. Consult UE if modification is necessary.

- Monitor operation to observe warning signs of possible damage to unit, such as drift in set point. Check unit immediately.

- Preventative maintenance/periodic testing is necessary for critical applications where damage could endanger property/ personnel.

- For all applications, a factory set unit should be tested before use.

Electrical ratings stated in literature and on nameplate must not be exceeded. Overload on a switch can cause possible damage on the first cycle. Wire unit according to local and national electrical codes, using wire size recommended in installation sheet.

- Use only factory authorized replacement parts and procedures.

- Do not mount unit in ambient temp. exceeding published limits.

- For remote mounted temperature units, capillary lengths beyond 10 feet can increase chance of error, and may require re-calibration of set point and indication.

### **LIMIT WARRANTY**

UE warrants that the product thereby purchased is, upon delivery, free from defects in material and workmanship and that any such product which is found to be defective in such workmanship or material will be repaired or replaced by UE (F.O.B. UE); provided, however, that this warranty applies only to equipment found to be so defective within a period of 12 months after installation by buyer but not to exceed 18 months after delivery by the seller. Except for the limited warranty of repair and replacement stated above, UE disclaims all warranties whatsoever with respect to the product, including all implied warranties of merchantability or fitness for any particular purpose.

### **LIABILITY LIMITATION**

The sole and exclusive remedy of buyer for any liability or seller for any claim, including incurred in connection with (I) breach of any warranty whatsoever expressed or implied, (II) a breach of contract, (III) a negligent act or acts (or negligent failure to act) committed by seller, or (IV) an act for which strict liability will be imputed to seller, is limited to the limited warranty or repair and replacement stated herein. In no event shall the seller be liable for any special, indirect, consequential or other damages or like general nature, including, without limitation, loss of profits or production, or loss or expenses of any nature, incurred by the buyer or any third party.



**UNITED ELECTRIC CONTROLS**

P.O. Box 9143, Watertown, MA 02272-9143 USA  
617 926-1000 Fax 617 926-2568

# INSTALLATION & MAINTENANCE INSTRUCTIONS

**ASCO**<sup>®</sup>  
SERIES

**ASCO**<sup>®</sup> **TRI-POINT**<sup>®</sup> Pressure Switches

MINIATURE-SIZE, FIXED DEADBAND PRESSURE SWITCHES  
WITH FIELD ADJUSTABLE SET POINTS

H

Form No. P7079R2

## DESCRIPTION

Series H are miniature size pressure switches having field adjustable set points, fixed deadbands, and diaphragm/piston sensors. These pressure switches are designed to provide long life and maintain set point accuracy. Materials wetted by the process fluid include pressure connections of brass or stainless steel, and internal elastomers of Buna N, styrene propylene, fluorosilicone, or VITON<sup>®</sup> depending upon service requirements.

Series H pressure switches are available with:

- Open frame construction
- Type 1-General Purpose Enclosure
- Types 2, 3S, and 4-Rainight/Watertight Enclosure

## OPERATION

The pressure switch will control electrical circuits in response to changes in pressure. The set and reset points are adjustable over the full range of the switch. As the switch is adjusted both set point on increasing pressure and set point on decreasing pressure are changed; the difference between this is fixed and is not adjustable. Pressure setting adjustments are made by turning the adjustment wheel at the center of the switch.

NOTE: The maximum overrange pressure for Series H pressure switches is 250 psig.

## INSTALLATION

Check the nameplate for the correct catalog number, electrical rating, and pressure range.

Pressure setting adjustments are made by turning the adjustment wheel at the center of the switch. IMPORTANT: All internal adjustments have been made at the factory. Any adjustment, alteration or repair to the parts of the switch other than stated herein voids all warranties.

## Temperature Limitations

- Standard Switch Ambient: -4°F to +140°F
- Suffix "U" Switch Ambient: -4°F to +122°F

Check catalog number on nameplate to determine fluid temperature limitations. The seventh (7th) digit in the catalog number indicates diaphragm material and fluid temperature limitations. See chart below.

Seventh (7th) Digit in Catalog Number	Diaphragm Material	Fluid Temperature Limitations
1	Buna N	-4°F to +180°F
2	VITON <sup>®</sup>	-4°F to +250°F
6	Ethylene Propylene	-4°F to +250°F
7	Fluorosilicone	-40°F to +250°F

EXAMPLE: For Catalog Number HB-6A278, the seventh digit of the catalog number is 2. This indicates that the diaphragm material is Fluorosilicone and the fluid temperature limitations are -40°F to +250°F.

## Positioning

The pressure switch may be mounted in any position.

## Mounting

For mounting bracket (optional feature) or mounting dimensions, for the general purpose switch refer to Figure 3.

## Piping/Tubing

Adequate support of piping and proper mounting of pressure switch should be made to avoid excessive shock or vibration. To minimize the effect of vibration on a switch, mount perpendicular to vibration. Connect piping or tubing at base of pressure switch. CAUTION: Do not use 1/2" pipe thread on pressure switch body as a pressure connection. This thread is provided for mounting the pressure switch in a panel enclosure or mounting bracket through a 7/8" diameter hole.

CAUTION: Pressure switches with the seventh (7th) digit in the catalog number being a six (6) are provided with ethylene propylene diaphragm material which can be attacked by oils and greases. Wipe the pipe threads clean of cutting oils. Apply pipe compound sparingly to male pipe threads only. If applied to internal threads, the compound may enter the sensor and cause operational difficulty. Avoid pipe strain on pressure switch by properly supporting and aligning piping. When tightening pipe, do not use the pressure switch as a lever. Locate wrenches applied to pressure switch body on wrenching flats only.

CAUTION: For steam service, install a condensate loop (pigtail or steam siphon tube) between the steam line and the pressure switch.

## Wiring

Wiring must comply with local codes and the National Electric Code. Use No. 14 AWG copper wire rated for 60°C minimum. Switch is marked "NO" for Normally Open, "NC" for Normally Closed, and "C" for Common. The general purpose switch enclosure is provided with two 7/8" diameter knockouts to accommodate 1/2" electrical hub or connector. For extra support, leave switch housing assembled when driving out 7/8" diameter knockout. It is recommended that flexible conduit be used. If rigid conduit is used, do not consider it or use it as a means of supporting (mounting) the pressure switch. The rainight/watertight switch enclosure is provided with a 1/2" conduit hub. When replacing housing cover, torque screws in a crisscross manner to 10 inch-pounds (1.1 newton-meters) to insure even gasket compression.

CAUTION: Electrical load must be within range stated on nameplate. Failure to stay within the electrical range of the switch rating may result in damage to or premature failure of the electrical switch. CAUTION: Do not over-tighten terminal connections. When connections are made, be sure there is no stress on the wire leads. Excess of either condition may cause malfunction of switch.

### STANDARD SWITCH RATINGS (Single Pole, Double Throw)

Maximum Load  
15 amps resistive, 250 volts AC  
1/8 HP, 125 volts AC  
1/4 HP, 250 volts AC  
1/2 amp resistive, 125 volts DC  
1/4 amp resistive, 250 volts DC

### SUFFIX "U" SWITCH RATINGS (Single Pole, Double Throw)

Maximum Load  
5 amps resistive, 125 and 250 volts AC  
1/8 HP, 125 volts AC  
1/4 HP, 250 volts AC  
1/2 amp resistive, 125 volts DC  
1/4 amp resistive, 250 volts DC

IMPORTANT: Series H pressure switches are available with optional snap switches which have different electrical ratings than listed above. Check nameplate on housing cover or frame to verify electrical ratings.

\*DuPont Co. Registered Trademark

Form No. P7079R2

Printed in U.S.A.

## Set Point Adjustment (Pressure Setting) of Fixed Deadband Pressure Switch

When making adjustment (pressure setting) a pressure gauge with suitable range is required. If electrical hook-up (to line of final application) to the switch is not desirable, a battery powered test lamp or ammeter may be used. The markings on the pressure switch calibration scale (in PSI or BAR) are for an approximate pressure setting. The adjustment wheel in the center of the pressure switch is turned clockwise or counterclockwise to change pressure setting. For an exact pressure setting proceed as follows:

### To Adjust Set Point on "Increasing Pressure"

1. If the pressure switch is in the line of final application when set point adjustment is made, be sure switch can be test operated without affecting other equipment.
2. Turn adjustment wheel clockwise until indicator is full down (toward pressure connection) or well beyond desired pressure setting (set point).
3. Follow the steps in the chart below to make the pressure setting.

Adjustment Procedure	Normally Closed		Normally Open	
	Switch Terminal	Status Of Test Lamp	Switch Terminal	Status Of Test Lamp
1. Starting with zero pressure, connect test lamp to common and ...	NC	On (Closed Circuit)	NO	Off (Open Circuit)
2. Apply desired set point pressure. Then turn adjustment wheel counterclockwise until switch operates.	NC	Off (Open Circuit)	NO	On (Closed Circuit)
3. Lower pressure until switch returns on decreasing pressure.	NC	On (Closed Circuit)	NO	Off (Open Circuit)

4. For exact pressure setting, cycle pressure switch and make fine adjustments with wheel.
5. After setting has been made, make permanent electrical connections. WARNING: Be sure power is off when electrical connections are made.

### To Adjust Set Point on "Decreasing Pressure"

1. If the pressure switch is in the line of final application when set point adjustment is made, be sure switch can be test operated without affecting other equipment.
2. Turn adjustment wheel counterclockwise until indicator is full up (toward snap switch).
3. Follow the steps in the chart below to make the pressure setting.

Adjustment Procedure	Normally Closed		Normally Open	
	Switch Terminal	Status Of Test Lamp	Switch Terminal	Status Of Test Lamp
1. Starting with initial pressure above desired pressure (set point), connect test lamp to common and ...	NC	Off (Open Circuit)	NO	On (Closed Circuit)
2. Decrease pressure to desired set point pressure. Then turn adjustment wheel clockwise until switch operates.	NC	On (Closed Circuit)	NO	Off (Open Circuit)
3. Increase pressure until switch returns on increasing pressure.	NC	Off (Open Circuit)	NO	On (Closed Circuit)

4. For exact pressure setting, cycle pressure to pressure switch and make fine adjustments with wheel.
5. After setting has been made, make permanent electrical connections. WARNING: Be sure power is off when electrical connections are made.

## Testing of Installation

If the adjustment of the switch has been made outside of the line of final application, the switch should be retested when installed in the line of final application. Follow adjustment instructions. Be sure switch can be test operated without affecting other equipment.

## MAINTENANCE

WARNING: Turn off electrical power supply and line pressure to switch before removal or inspection. IMPORTANT: Pressure switch is not field repairable. In case of damage, replace the entire pressure switch. Address all service inquiries to Automatic Switch Company, 50-60 Hanover Road, Florham Park, New Jersey 07932, Valve Service Department.

### Preventive Maintenance

1. While in service, operate the fixed deadband pressure switch periodically (cycle between two set points) to insure proper operation. If necessary, electrical wiring and pipe connections should be made so that switch can be test operated without affecting other equipment.
2. Periodic inspection of the pressure switch, external surfaces only, should be carried out. Switch should be kept clean and free from paint, foreign matter, corrosion, icing, and freezing conditions.
3. Keep the medium entering the pressure switch as free from dirt and foreign material as possible.

Automatic Switch Co. 50-60 Hanover Road, Florham Park, New Jersey 07932

© Automatic Switch Co. MCMLXXXII. All Rights Reserved



### Causes of Improper Operation

1. **Incorrect Electrical Connection:** Check leads to switch. Be sure they are properly connected. Switch is marked "NO" for Normally Open, "NC" for Normally Closed and "C" for Common.
2. **Faulty Control Circuit:** Check electrical power supply to switch. Check for loose or blown fuses, open-circuited or grounded wires, loose connections at switch. See nameplate for electrical rating and range.
3. **Incorrect Pressure:** Check pressure in system with suitable pressure gauge. Pressure must be within range specified on nameplate.
4. **Incorrect Adjustment:** Check pressure scale to see approximate setting. Refer to section on "Set Point Adjustment of Fixed Deadband Pressure Switch".
5. **External Leakage or Snap Switch Failure:** Replace pressure switch, see "ORDERING INFORMATION."
6. **Excessive Vibration or Surges Causing Switch to Operate Undesirably:** Check for pressure fluctuations in system and install pressure surge suppressor. Check switch mounting and be sure there is no excessive vibration.

If the operation of the pressure switch cannot be corrected by the above means, it should be replaced.

FOR SERVICE, REPLACEMENT OR INFORMATION  
Consult Factory or Authorized Factory Representative  
or Distributors

ORDERING INFORMATION  
When Ordering, Specify Catalog Number,  
Fluid, and Pressure Range.

NAMEPLATES ARE LOCATED ON HOUSING COVER  
OR ARE PART OF THE  
PRESSURE SCALE.

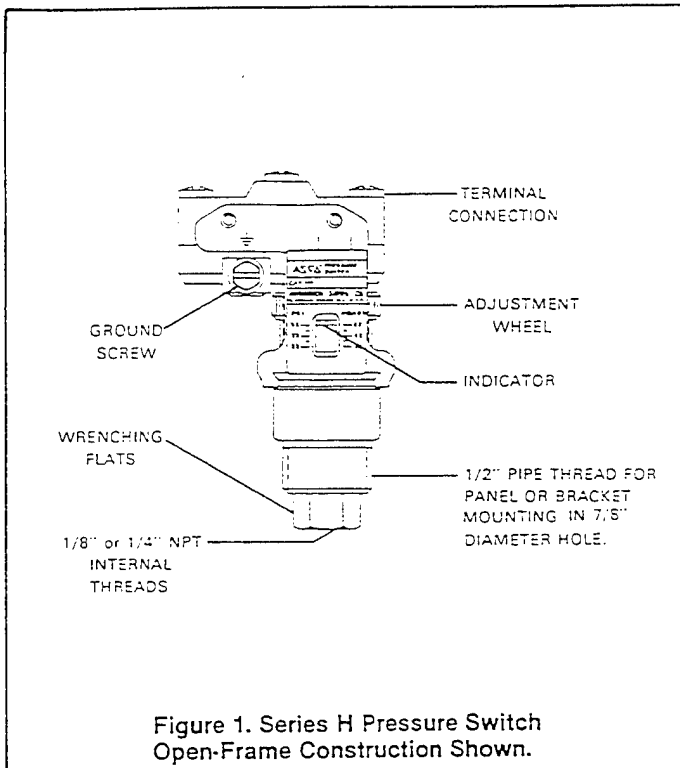

Figure 1. Series H Pressure Switch Open-Frame Construction Shown.

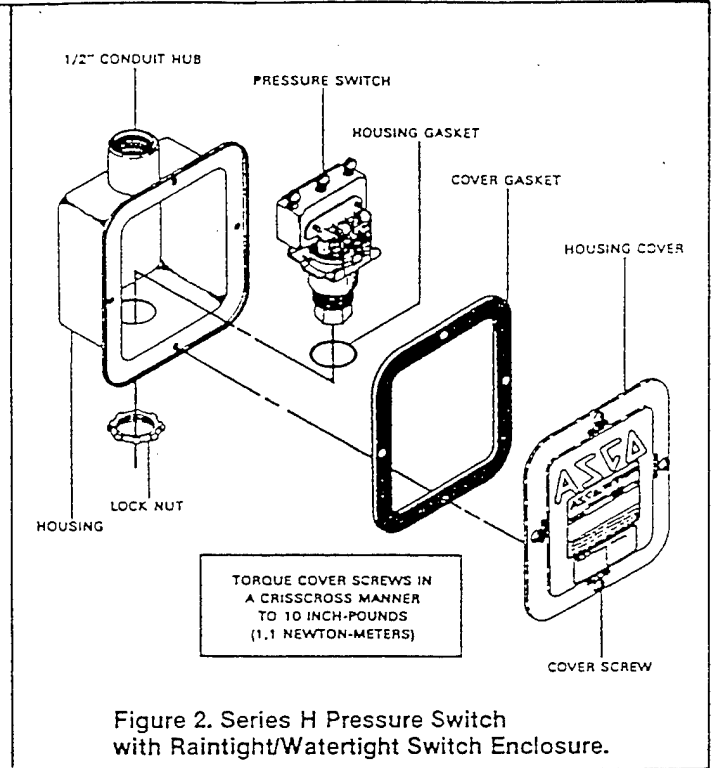

Figure 2. Series H Pressure Switch with Raintight/Watertight Switch Enclosure.

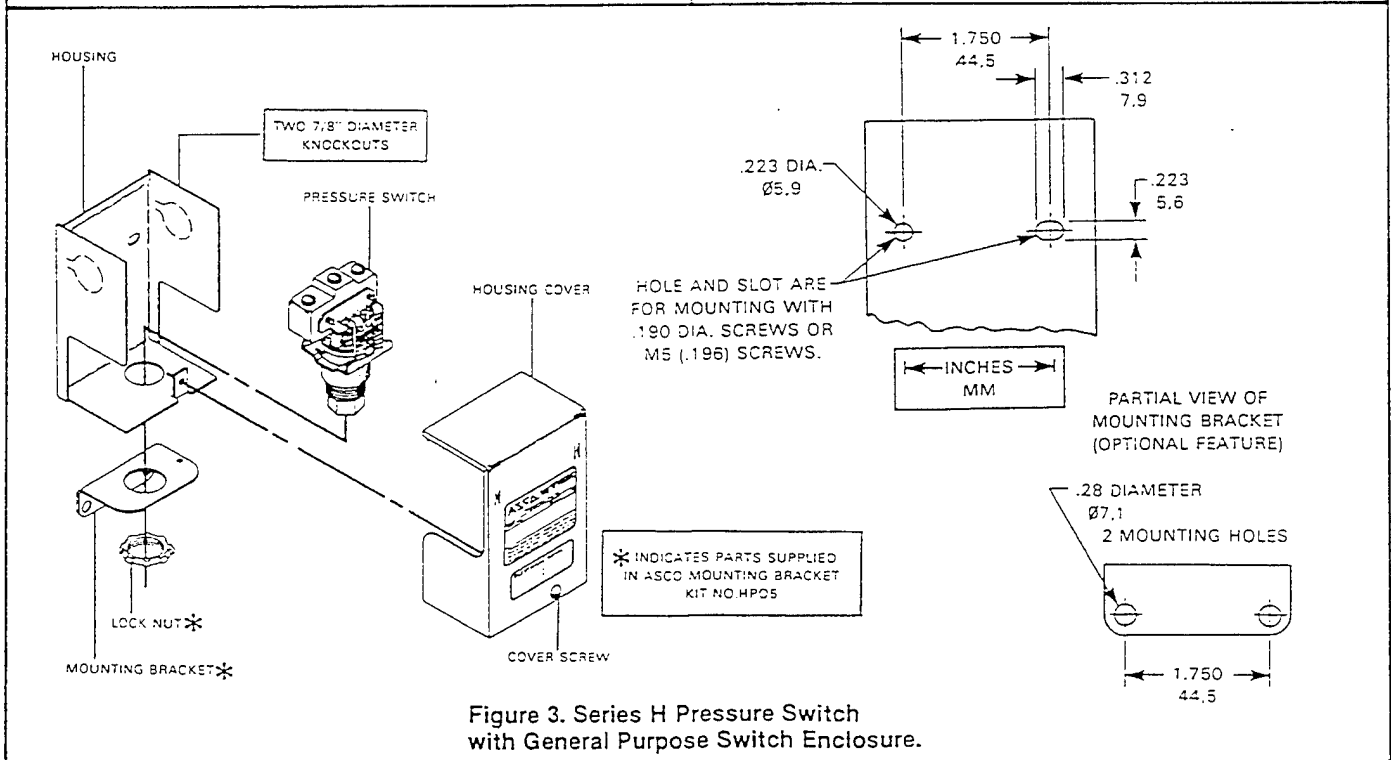

Figure 3. Series H Pressure Switch with General Purpose Switch Enclosure.



# INSTALLATION & MAINTENANCE INSTRUCTIONS

## ASCO Red-Hat II SOLENOIDS

ASCO<sup>®</sup>  
BULLETINS

8003G

8202G

Form No. V6584R1

OPEN-FRAME, GENERAL PURPOSE AND WATERTIGHT/EXPLOSIONPROOF  
(INCLUDING OPTIONAL FEATURES)

### SERVICE NOTICE

ASCO<sup>®</sup> solenoid valves with design change letter "G" in the catalog number (example: 8210G) have an epoxy encapsulated ASCO<sup>®</sup> Red Hat II solenoid. This solenoid replaces some of the solenoids with metal enclosures and the open-frame constructions.

Follow these installation and maintenance instructions if your valve or operator uses this solenoid.

### DESCRIPTION

Catalog numbers 8003G1 and 8003G2 are epoxy encapsulated pull-type solenoids. The green solenoid with lead wires and 1/2" conduit connection is designed to meet Enclosure Type 1 - General Purpose, Type 2-Dripproof, Types 3 and 3S-Raintight, and Types 4 and 4X-Watertight. The black solenoid on catalog numbers prefixed "EF" is designed to meet Enclosure Types 3 and 3S-Raintight, Types 4 and 4X-Watertight, Types 5 and 5P-Submersible, Type 7 (A, B, C, & D) Explosionproof Class I, Groups A, B, C & D and Type 9 (E, F, & G)-Dust Ignitionproof Class II, Groups E, F, & G. The Class II, Groups F & G Dust Locations designation is not applicable for solenoids or solenoid valves used for steam service or when a class "H" solenoid is used. See "Temperature Limitations" section for solenoid identification and nameplate, retainer for service. When installed just as a solenoid and not attached to an ASCO valve, the core has a 0.250-28 UNF-2B tapped hole, 0.33 or 0.63 minimum full thread.

Catalog numbers 8202G1, 8202G3, 8202G5 and 8202G7 are epoxy encapsulated push-type, reversing solenoids having the same enclosure types as previously stated for Catalog numbers 8003G1 and 8003G2.

Bulletins 8003G and 8202G solenoids are available in:

- Open-Frame Construction: The green solenoid may be supplied with 1/4" spade, screw, or DIN terminals. (Refer to Figure 4)
- Panel Mounted Construction: These solenoids are specifically designed to be panel mounted by the customer through a panel having a .0625-.093 maximum wall thickness. Refer to Figure 1 and section on "Installation of Panel Mounted Solenoid".
- Optional Features For Type 1 - General Purpose Construction Only
  - Junction Box: This junction box construction meets Enclosure Types 2, 3, 3S, 4, and 4X. Only solenoids with 1/4" spade or screw terminals may have a junction box. The junction box provides a 1/2" conduit connection, grounding and spade or screw terminal connections within the junction box (See Figure 5).
  - Plug Connector Kit No. K236-034: Use this kit only for solenoids with with DIN terminals. The plug connector kit provides a two pole with grounding contact DIN Type 4350 construction (See Figure 5).

### OPERATION

Bulletin 8003G - When the solenoid is energized, the core is drawn into the solenoid base sub-assembly. **IMPORTANT:** When the solenoid is de-energized, the initial return force for the core, whether developed by spring, pressure, or weight, must exert a minimum force to overcome residual magnetism created by the solenoid. Minimum return force for AC Construction is 11 ounces, and 5 ounces for DC Construction.

Bulletin 8202G - When the solenoid is energized, the disc holder assembly seats against the orifice. When the solenoid is de-energized, the disc holder assembly returns. **IMPORTANT:** Initial return force for the disc or disc holder assembly, whether developed by spring, pressure, or weight, must exert a minimum force to overcome residual magnetism created by the solenoid. Minimum return force is 1 pound, 5 ounces.

### INSTALLATION

Check nameplate for correct catalog number, service and voltage. Check front of solenoid for voltage and frequency.

**WARNING:** To prevent the possibility of electrical shock from the accessibility of live parts, install the open-frame solenoid in an enclosure.

### FOR BLACK ENCLOSURE TYPES 7 AND 9 ONLY

**CAUTION:** To prevent fire or explosion, do not install solenoid and/or valve where ignition temperature of hazardous atmosphere is less than 165°C. On valves used on steam service or when a class "H" solenoid is used, do not install in hazardous atmosphere where ignition temperature is less than 180°C. See nameplate/retainer for service.

**NOTE:** These solenoids have an internal non-resettable thermal fuse to limit solenoid temperature in the event that extraordinary conditions occur which could cause excessive temperatures. These conditions include high input voltage, a jammed core, excessive ambient temperature or a shorted solenoid, etc. This unique feature is a standard feature only in solenoids with black explosionproof/dust-ignitionproof enclosures (Types 7 & 9).

**IMPORTANT:** To protect the solenoid valve or operator, install a strainer or filter, suitable for the service involved in the inlet side as close to the valve or operator as possible. Clean periodically depending on service conditions. See ASCO Bulletins 3600, 3601 and 3602 for strainers.

### Temperature Limitations

For maximum valve ambient temperatures, refer to chart. The temperature limitations listed only indicate maximum application temperatures for field wiring rated at 90°C. Check catalog number prefix and watt rating on nameplate to determine maximum ambient temperature. See valve installation and maintenance instructions for maximum fluid temperature.

**NOTE:** For steam services, refer to "Wiring" section, "Junction Box" for temperature rating of supply wires.

### TEMPERATURE LIMITATIONS FOR BULLETINS 8003G OR 8202G SOLENOIDS OR VALVES RATED AT 10.1, 11.5, 17.1, or 22.5 WATTS

Watt Rating	Catalog Number Prefix	Solenoid Class	Maximum Ambient Temp. °F
10.1 & 17.1	None, FB, KF, KP, SC, SD, SF, & SP	F	125
10.1 & 17.1	HT, HB, KB, KH, SS, ST, SU, & SV	H	140
11.5 & 22.5	None, FB, KF, KP, SC, SD, SF, & SP	F	104
11.5 & 22.5	HB, HT, KB, KH, SS, ST, SU, & SV	H	104

### Positioning

This solenoid is designed to perform properly when mounted in any position. However, for optimum life and performance, the solenoid should be mounted vertically and upright to reduce the possibility of foreign matter accumulating in the solenoid base sub-assembly area.

### Wiring

Wiring must comply with local codes and the National Electrical Code. All solenoids supplied with lead wires are provided with a green grounding wire and a 1/2" conduit connection. To facilitate wiring, the solenoid may be rotated 360°. For the watertight and explosionproof solenoid, electrical fittings must be approved for use in the approved hazardous locations.

### Additional Wiring Instructions For Optional Features:

- Open-Frame solenoid with 1/4" spade or screw terminals.  
For solenoids supplied with screw terminal connections use #12-18 AWG stranded copper wire rated at 90°C or greater. Torque terminal block screws to 10 = 2 inch-pounds (1.1 = 0.2 newton-meters). A tapped hole is provided in the solenoid for grounding, use a #10-32 machine screw. Torque grounding screw to 25 = 5 inch-pounds (2.3 = 0.5 newton-meters). On solenoids with screw terminals, the socket head screw holding the terminal block to the solenoid is the grounding screw. Torque the screw to 25 = 5 inch-pounds (2.3 = 0.5 newton-meters) with a 5/32" hex key wrench.
- Junction Box  
The junction box is used with spade or screw terminal solenoids only and is provided with a grounding screw and a 1/2" conduit connection. Connect #12-18 AWG stranded copper wire only to the screw terminals. Within the junction box use field wire that is rated 90°C or greater for connections. For steam service use 105°C rated wire up to 50 psi or use 125°C rated wire above 50 psi. After electrical hookup, replace cover gasket, cover and screws. Tighten cover screws evenly in a crisscross manner.

### Plug Connector Kit No. K236-034 (optional)

1. The open-frame solenoid is provided with a spade connector with DIN terminals to accommodate the plug connector kit.
2. Remove center screw from plug connector. Using a small screwdriver, pry terminal block from connector housing.
3. Use #12-18 AWG stranded copper wire rated at 90°C or greater for connections. Strip wire leads back approximately 1/4" for installation in socket terminals. The use of wire-end sleeves is also recommended for these socket terminals. Maximum length of wire-end sleeves to be approximately 1/4". Tinning of the ends of the lead wires is not recommended.
4. Thread wire through gland nut, gland gasket, washer, and connector housing. **NOTE:** Connector housing may be rotated in 90° increments from position shown for alternate positioning of cable entry.
5. Check DIN connector terminal block for electrical markings. Then make electrical hookup to terminal block according to the markings on it. Strip terminal block into connector housing and install center screw.
6. Position connector gasket on solenoid and install plug connector. Torque center screw to 5 = 1 inch-pounds (0.6 = 0.1 newton-meters).

**NOTE:** Alternating current (AC) and direct current (DC) solenoids are built differently. To convert from one to the other, it may be necessary to change the complete solenoid including the core and solenoid base sub-assembly, not just the solenoid. Consult ASCO.

### Installation of Solenoid

Solenoids may be assembled as a complete unit. Tightening is accomplished by means of a hex flange at the base of the solenoid.

### Installation of Panel Mounted Solenoid

1. Disassemble solenoid following instruction under "Solenoid Replacement".
2. Install solenoid base sub-assembly through customer panel.
3. Position finger spring washer on opposite side of panel over solenoid base sub-assembly. The finger portion of the spring washer seats against the surface of the panel.
4. Replace solenoid, nameplate/retainer and red cap.
5. Make electrical hookup, see "Wiring" section.

### Solenoid Temperature

Standard solenoids are designed for continuous duty service. When the solenoid is energized for a long period, the solenoid becomes hot and can be touched by hand only for an instant. This is a safe operating temperature.

## MAINTENANCE

**WARNING:** Turn off electrical power supply and depressurize solenoid operator and/or valve before making repairs.

### Cleaning

All solenoid operators and valves should be cleaned periodically. The time between cleanings will vary depending on medium and service conditions. In general, if the voltage to the solenoid is correct, sluggish valve operation, excessive noise or leakage will indicate that cleaning is required. Clean strainer or filter when cleaning the valve.

### Preventive Maintenance

1. Keep the medium flowing through the solenoid operator or valve as free from dirt and foreign material as possible.
2. While in service, the solenoid operator or valve should be operated at least once a month to insure proper opening and closing.
3. Depending on the medium and service conditions, periodic inspection of internal valve parts for damage or excessive wear is recommended. Thoroughly clean all parts. Replace any parts that are worn or damaged.

### Causes Of Improper Operation

1. **Faulty Control Circuit:** Check the electrical system by energizing the solenoid. A metallic "click" signifies that the solenoid is operating. Absence of the "click" indicates loss of power supply. Check for loose or blown fuses, open-circuited or grounded solenoid, broken lead wires or splice connections.
2. **Burned-Out Solenoid:** Check for open-circuited solenoid. Replace if necessary. Check supply voltage; it must be the same as specified on nameplate and as marked on the solenoid. Check ambient temperature and check that the core is not jammed.
3. **Low Voltage:** Check voltage across the solenoid leads. Voltage must be at least 85% of rated voltage.

### Solenoid Replacement

**WARNING:** Turn off electrical power supply. For 3-way construction, depressurize solenoid operator or valve.

**CAUTION:** Check solenoid number and electrical service markings on front of new solenoid before installation.

#### Solenoids with Lead Wires:

1. Disconnect conduit, coil leads and grounding wire. Note: Any optional parts attached to the old solenoid must be reinstalled on the new solenoid. For 3-way construction, piping or tubing must be removed from pipe adapter.
2. Disassemble solenoids with optional features as follows:
  - A. **For Spade or Screw Terminals:** Remove terminal connections, grounding screw, grounding wire and terminal block (screw terminal type only). Note: For screw terminals, the socket head screw holding the terminal block serves as a grounding screw.
  - B. **For Junction Box:** Remove conduit and socket head screw (use 5/32" hex key wrench) from center of junction box. Disconnect junction box from solenoid.
  - C. **For Plug Connector:** Remove center screw from plug connector. Disconnect plug connector from plug connector adapter. Remove socket head screw (use 5/32" hex key wrench) DIN terminal block, and gasket from solenoid.
3. Snap off red cap from top of solenoid base sub-assembly. For 3-way construction with pipe adapter (Figure 3), remove pipe adapter, nameplate and solenoid. Omit steps 4 and 5.
4. Push down on solenoid. Then using a suitable screwdriver, insert blade between solenoid and nameplate/retainer. Pry up slightly then pull nameplate/retainer forward (toward electrical marking on solenoid) to disengage nameplate/retainer from solenoid base sub-assembly. Note: Bulletin 8202G solenoids have a spacer between the nameplate/retainer and solenoid.

5. Remove solenoid from solenoid base sub-assembly.
6. Reassemble in reverse order of disassembly. Use exploded views for identification and placement of parts.
7. Torque pipe adapter to 90 inch-pounds maximum (10.2 newton-meters maximum). Then make up piping or tubing to pipe adapter on solenoid.

### Disassembly and Reassembly of Solenoids

**NOTE:** Check nameplate for solenoid catalog number then proceed as follows:

**WARNING:** Turn off electrical power supply and depressurize solenoid operator and/or valve before making repairs.

1. Remove solenoid, see "Solenoid Replacement".
2. Remove finger spring washer from solenoid base sub-assembly. For 3-way construction, remove plugnut gasket.
3. Unscrew solenoid base sub-assembly and remove the following parts:

\*Catalog Nos.  
8003G1  
8003G2

• Core

\*Catalog Nos.  
8202G1  
8202G3  
(With Adapter Construction)

- Bonnet Washer
- Core
- Plugnut Assembly
- Solenoid Base Gasket
- Adapter Gasket
- Adapter
- Disc Holder Assembly
- Disc Holder Spring

\*Catalog Nos.  
8202G5  
8202G7  
(Without Adapter Construction)

- Bonnet Washer
- Core
- Plugnut Assembly
- Solenoid Base Gasket
- Stem
- Disc
- Disc Spring Gasket
- Retainer

\* Includes catalog numbers with prefix "EF" or "OF".

4. Internal solenoid parts are now accessible for cleaning or replacement.
5. If the solenoid is part of a valve, refer to basic valve installation and maintenance instructions for further disassembly.
6. Reassemble solenoid in reverse order of disassembly. Use exploded views for identification and placement of parts.
7. Torque solenoid base sub-assembly (into adapter) to 175 ± 25 inch-pounds (19.3 ± 2.8 newton-meters).

## ORDERING INFORMATION FOR ASCO SOLENOIDS

When Ordering Solenoids for ASCO Solenoid Operators or Valves, order the number stamped on your solenoid. Also specify voltage and frequency.

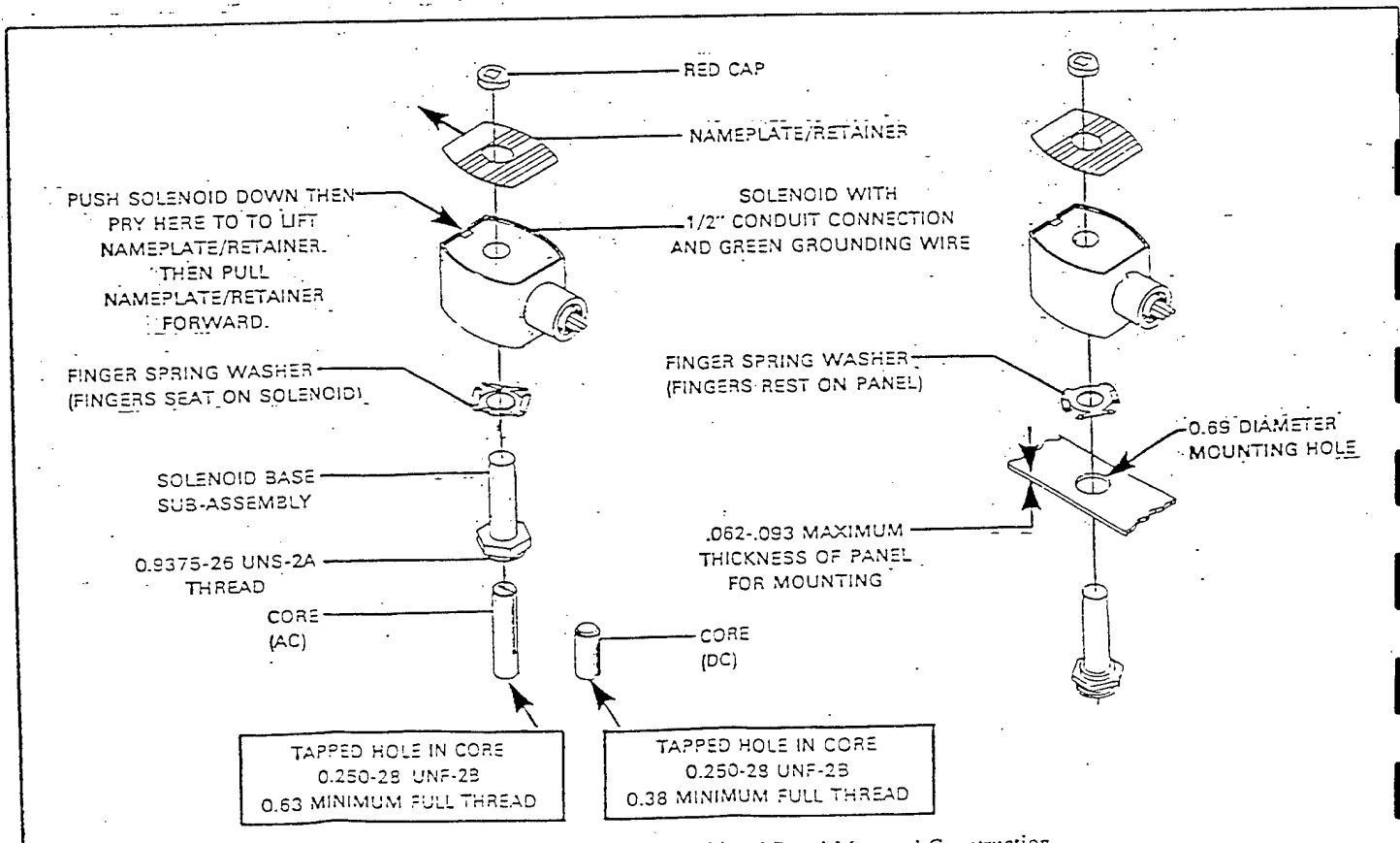

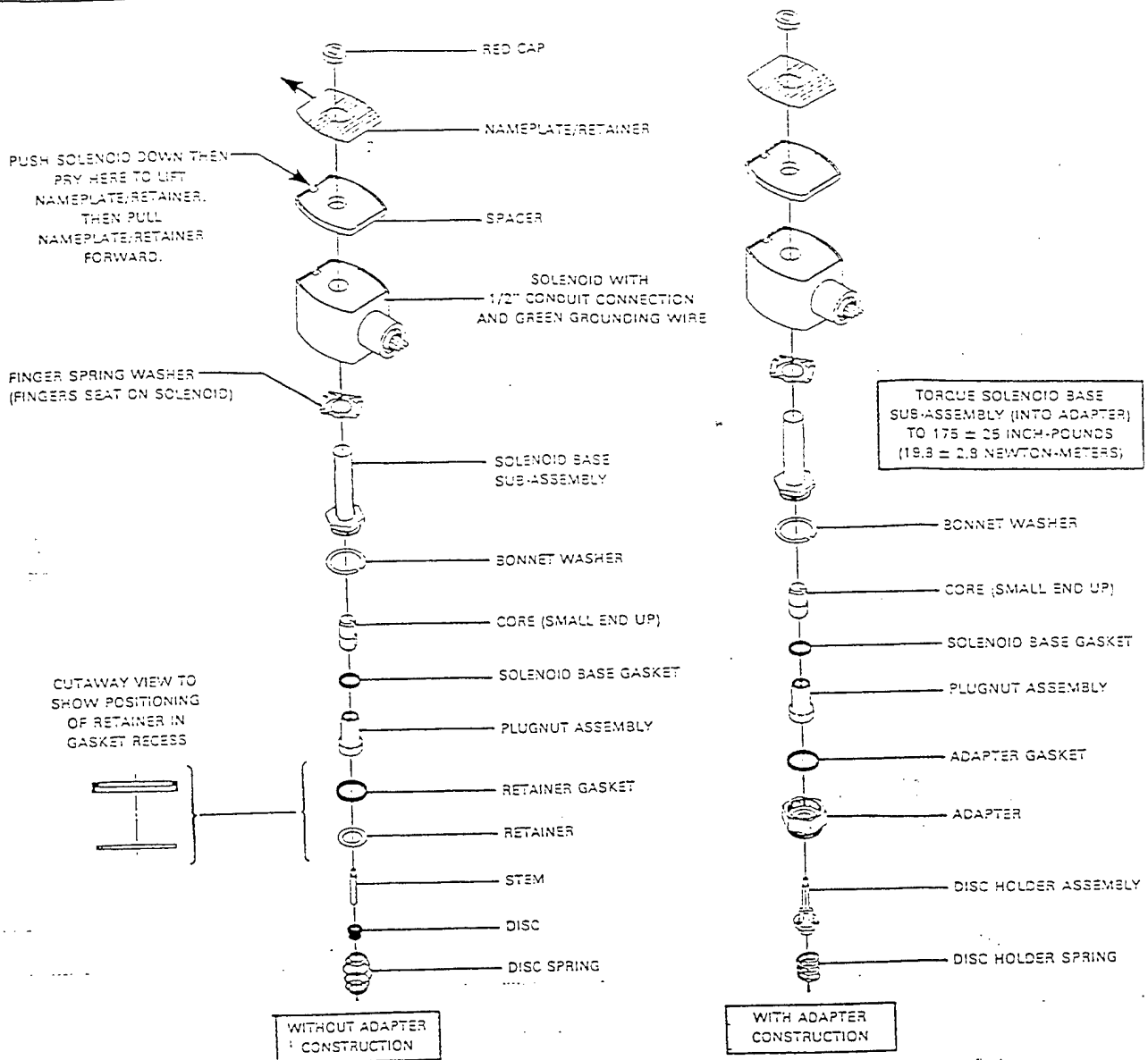

Figure 2. Bulletin 3202G Solenoids

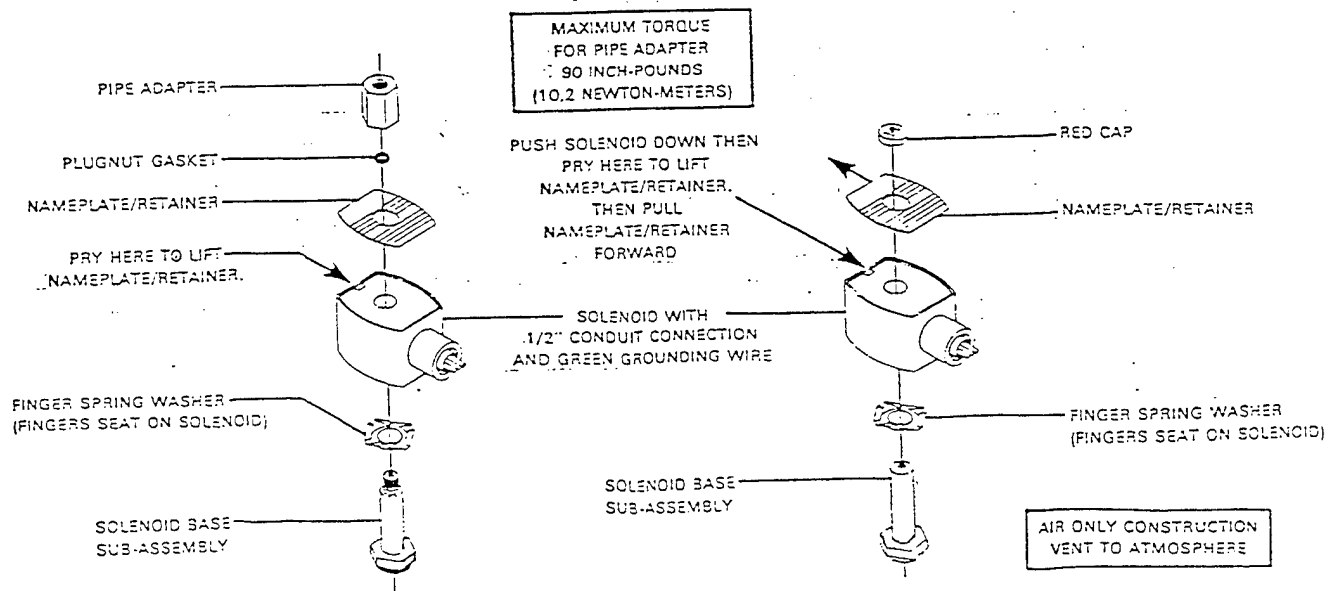

Figure 3. 3-Way Construction

OPEN-FRAME SOLENOID WITH 1/4" SPADE TERMINALS



TORQUE TERMINAL BLOCK SCREWS TO  $10 \pm 2$  INCH-POUNDS ( $1.1 \pm 0.2$  NEWTON-METERS)

OPEN-FRAME SOLENOID WITH SCREW TERMINALS. SOCKET HEAD SCREW IS USED FOR GROUNDING

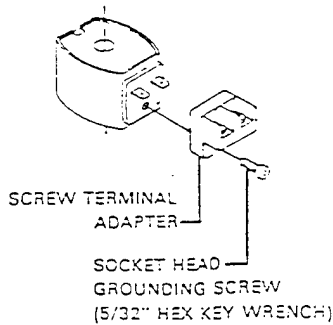

OPEN-FRAME SOLENOID WITH 1/4" SPADE TERMINALS FOR PLUG CONNECTOR ADAPTER

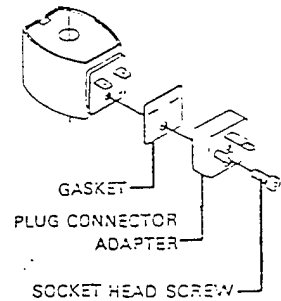

TORQUE SOCKET HEAD SCREW TO  $25 \pm 5$  INCH-POUNDS ( $2.8 \pm 0.6$  NEWTON-METERS)

Figure 4. Open-Frame Solenoids

TIGHTEN COVER SCREWS EVENLY IN A CRISSCROSS MANNER

OPEN-FRAME SOLENOID WITH 1/4" SPADE TERMINALS

TORQUE TERMINAL BLOCK SCREWS TO  $10 \pm 2$  INCH-POUNDS ( $1.1 \pm 0.2$  NEWTON-METERS)

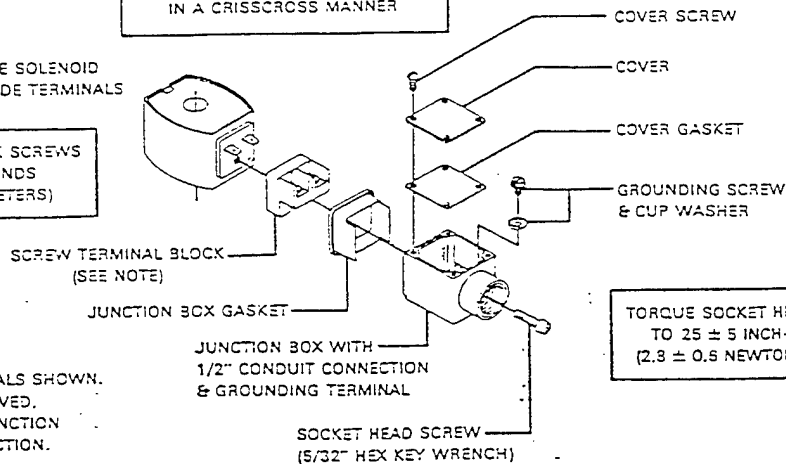

TORQUE SOCKET HEAD SCREW TO  $25 \pm 5$  INCH-POUNDS ( $2.8 \pm 0.6$  NEWTON-METERS)

NOTE: JUNCTION BOX WITH SCREW TERMINALS SHOWN. WITH SCREW TERMINAL BLOCK REMOVED, REMAINING PARTS COMPRISE THE JUNCTION BOX FOR SPADE TERMINAL CONSTRUCTION.

Figure 5. Junction Box (Optional Feature)

\* INDICATES THAT THESE PARTS ARE INCLUDED IN PLUG CONNECTOR KIT NO. K236-034

OPEN-FRAME SOLENOID WITH 1/4" SPADE TERMINALS

TORQUE SOCKET HEAD SCREW TO  $25 \pm 5$  INCH-POUNDS ( $2.8 \pm 0.6$  NEWTON-METERS)

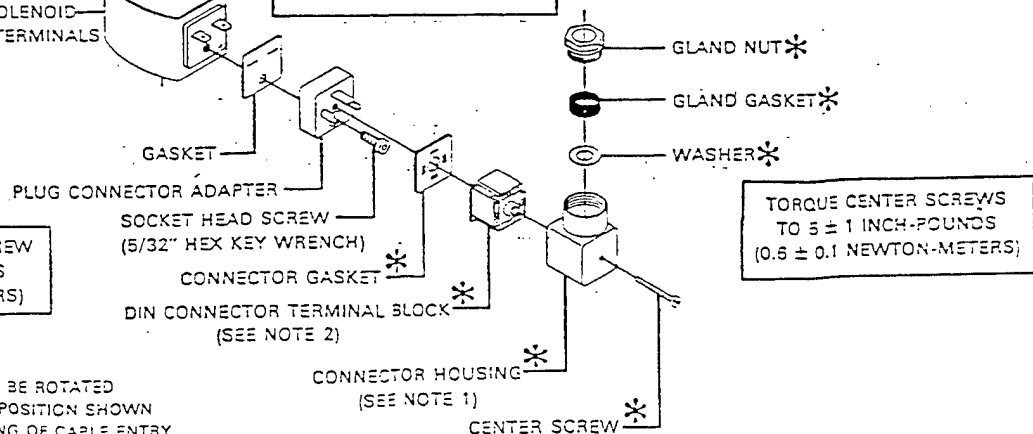

TORQUE CENTER SCREWS TO  $5 \pm 1$  INCH-POUNDS ( $0.6 \pm 0.1$  NEWTON-METERS)

NOTES:  
1. CONNECTOR HOUSING MAY BE ROTATED IN 90° INCREMENTS FROM POSITION SHOWN FOR ALTERNATE POSITIONING OF CABLE ENTRY.  
2. REFER TO MARKINGS ON DIN CONNECTOR FOR PROPER ELECTRICAL CONNECTIONS.

Figure 6. Plug Connector Kit No. K236-034 (Optional Feature)

# INSTALLATION AND MAINTENANCE INSTRUCTIONS

2-WAY INTERNAL PILOT OPERATED SOLENOID VALVES  
PISTON TYPE — 3/4 AND 1" N.P.T.  
NORMALLY CLOSED OPERATION

BULLETINS

8210  
8211



Form No. V-5411R2

## DESCRIPTION

Bulletin 8210's are 2-way, normally closed, internal pilot operated, piston type solenoid valves. Standard valves have a General Purpose, NEMA Type 1 Solenoid Enclosure. Bulletin 8211's are the same as Bulletin 8210's except they are provided with an enclosure which is designed to meet NEMA Type 4 - Watertight, NEMA Type 7 (C or D) Hazardous Locations - Class I, Group C or D and NEMA Type 9 (E, F or G) Hazardous Locations - Class II, Group E, F or G. For explosion-proof/watertight solenoid enclosure used for A-C Construction, see Form No. V-5351.

## OPERATION

Normally Closed: Valve is closed when solenoid is de-energized and opens when solenoid is energized.

### MANUAL OPERATOR (Optional)

Valves with suffix 'MO' in catalog number are provided with a manual operator which allows manual operation when desired or during an interruption of electrical power.

## OPERATION

For 1 inch N.P.T. Valves: To open, push knob upward and rotate 1/2 turn. Rotate 1/2 turn to close.  
For 3/4 inch N.P.T. Valves: To open, turn stem clockwise. To close turn stem counter-clockwise.  
**CAUTION:** Stem must be fully retracted before operating valve electrically.

## INSTALLATION

Check nameplate for correct catalog number, pressure, voltage and service.

### TEMPERATURE LIMITATIONS

For maximum valve ambient and fluid temperature limitations, refer to chart below. The temperature limitations listed are for UL applications. For other valves and non UL applications, higher ambient and fluid temperature limitations are available. Consult factory. Check catalog number on nameplate to determine maximum temperatures.

Catalog Number	Catalog Number Prefix	Coil Class	Maximum Ambient Temp. °F	Maximum Fluid Temp. °F
8210B26 A-C Construction Only (Alternating Current)	None or DA	A	77	260
	FT	F	104	260
	HT	H	140	260
8210B27	None	F	77	260

## POSITIONING

Valve must be mounted with solenoid vertical and upright.

## PIPING

Connect piping to valve according to markings on the valve body. Apply pipe compound sparingly to male pipe threads only; if applied to valve threads, it may enter valve and cause operational difficulty. Pipe strain on valve body should be avoided by proper support and alignment of piping. When tightening connections, do not use body or solenoid as a lever. Wrenches applied to valve body or piping are to be located as close as possible to connection point.

**IMPORTANT:** For protection of solenoid valve, install a strainer or filter suitable for the service involved in the inlet side as close to valve as possible. Periodic cleaning is required depending on service conditions. See Bulletins 8600, 8601 and 8602 for strainers.

## WIRING

Wiring must comply with Local and National Electrical Codes. For valves equipped with an explosion-proof/watertight solenoid enclosure, the electrical fittings must be approved for use in the approved hazardous locations. Housings for all solenoids are made with connections for 1/2 inch conduit. The general purpose solenoid enclosure and the explosion-proof/watertight solenoid enclosure may be rotated to facilitate wiring by loosening the cover or removing the retaining cap or clip. **CAUTION:** When metal retaining clip disengages it will spring upwards. Rotate enclosure to desired position. Tighten cover or replace retaining cap or clip before operating. Torque cover on explosion-proof/watertight solenoid enclosure to 135 ± 10 inch pounds.

## SOLENOID TEMPERATURE

Standard catalog valves are supplied with coils designed for continuous duty service. When solenoid is energized for a long period, solenoid enclosure becomes hot and can be touched by the hand for only an instant. This is a safe operating temperature. Any excessive heating will be indicated by the smoke and odor of burning coil insulation.

## MAINTENANCE

**WARNING:** Turn off electrical power supply and depressurize valve before making repairs. It is not necessary to remove valve from pipe line for repairs.

### CLEANING

A periodic cleaning of all solenoid valves is desirable. The time between cleanings will vary depending on media and service conditions. In general, if voltage to coil is correct, sluggish valve operation, excessive leakage or noise will indicate cleaning is required.

### PREVENTIVE MAINTENANCE

1. Keep the medium flowing through the valve as free from dirt and foreign material as possible.
2. While in service, operate valve at least once a month to insure proper opening and closing.

3. Periodic inspection (depending on media and service conditions) of internal valve parts for damage or excessive wear is recommended. Thoroughly clean all parts. Replace any parts that are worn or damaged.

### IMPROPER OPERATION

1. **Faulty Control Circuit:** Check the electrical system by energizing the solenoid. A metallic click signifies that the solenoid is operating. Absence of the click indicates loss of power supply. Check for loose or blown-out fuses, open circuited or grounded coil, broken lead wires or splice connections.
2. **Burned-Out Coil:** Check for open circuited coil. Replace coil if necessary.
3. **Low Voltage:** Check voltage across the coil leads. Voltage must be at least 85% of nameplate rating.
4. **Incorrect Pressure:** Check valve pressure. Pressure to valve must be within the range specified on nameplate.
5. **Excessive Leakage:** Disassemble valve and clean all parts. Replace parts that are worn or damaged with a complete Spare Parts Kit for best results. Damage to seating surface may also cause leakage.
6. **Improper Opening and Closing:** Check for worn or damaged piston ring and clogged internal passages. Clean piston bleed hole and orifice in piston.

### COIL REPLACEMENT (Refer to Figures 1, 2 and 3)

Turn off electrical power supply and disconnect coil lead wires.

### A-C CONSTRUCTION (Refer to Figures 1 and 2)

1. Remove retaining cap or clip, nameplate and cover. **CAUTION:** When metal retaining clip disengages it will spring upwards.
2. Slip yoke containing coil, sleeves and insulating washers off the solenoid base sub-assembly. Insulating washers are omitted when a molded coil is used.
3. Remove coil, sleeves and insulating washers from yoke.
4. Reassemble in reverse order of disassembly paying careful attention to exploded views provided for identification and placement of parts.

### D-C CONSTRUCTION (Refer to Figure 3)

1. Unscrew cover with nameplate and retaining ring attached.
2. Slip spring, fluxwasher, insulating washer and coil off the solenoid base sub-assembly. Insulating washers are omitted when a molded coil is used.
3. Reassemble in reverse order of disassembly paying careful attention to exploded views provided for identification and placement of parts.
4. Torque cover on solenoid enclosure to 135 ± 10 inch pounds.

**CAUTION:** The solenoid must be fully reassembled as the housing and internal parts are part of and complete the magnetic circuit. Place insulating washers at each end of coil if required.

**NOTE:** Installation and maintenance of explosion-proof equipment requires more than ordinary care to insure safe performance. All finished surfaces of the solenoid are constructed to provide a flameproof seal. Be sure that surfaces are wiped clean before replacing. If watertight, as well as explosion-proof is a requirement, grease the joints of the explosion-proof/watertight solenoid with Exxon Company, U.S.A. Nebula EP-2 grease or equivalent. A high grade silicone grease similar to Dow Corning's Valve Seal may also be used.

### VALVE DISASSEMBLY & REASSEMBLY (Refer to Figs. 1, 2 & 3)

Depressurize valve and turn off electrical power supply. Disconnect conduit and lead wires when necessary. Proceed in the following manner:

1. For the general purpose solenoid enclosure remove the retaining cap or clip and slip the entire solenoid enclosure off the solenoid base sub-assembly. **CAUTION:** When metal retaining clip disengages it will spring upwards. For explosion-proof/watertight construction or general purpose D-C construction, follow disassembly instructions under 'Coil Replacement, D-C Construction.'
2. Unscrew solenoid base sub-assembly. For D-C construction a special wrench adapter (Order No. 168-146-1) is required. Remove bonnet gasket.
3. Remove bonnet screws (4), valve bonnet and body gasket. Remove piston/core sub-assembly and core spring.
4. All internal parts are now accessible for cleaning or replacement. Replace worn or damaged parts with a complete Spare Parts Kit for best results.
5. For normal maintenance it is not necessary to disassemble the manual operator unless external leakage is evident. If disassembly is required, refer to manual operator paragraph. **IMPORTANT:** If Spare Parts Kits are installed in 1 inch N.P.T. valves, Catalog Nos. 8210B27MO or 8211B27MO (valves supplied with manual operator) all new manual operator parts provided in Spare Parts Kits must be installed. Failure to install new manual operator parts will result in valve malfunction.
6. Reassemble in reverse order of disassembly paying careful attention to exploded views provided for identification and placement of parts.
7. Replace body gasket in groove in valve body.
8. Insert piston/core sub-assembly in bonnet. To prevent damage, compress rider rings and piston ring when preassembling piston/core sub-assembly in valve bonnet. Be sure there is free movement of the piston assembly.
9. When replacing bonnet with piston/core sub-assembly compressed inside of it, a flat steel rule (or similar flat tool) may be used to retain the piston/core sub-assembly in the valve bonnet while bonnet is engaged to the valve body. Torque bonnet screws (4) in a crisscross manner to 110 ± 10 inch pounds.
10. Replace core spring with closed end protruding from the top of the core, bonnet gasket and solenoid base sub-assembly. Torque solenoid base sub-assembly to 175 ± 25 inch pounds.
11. Reassemble solenoid and operate the valve a few times to be sure there is no binding or misalignment of internal parts.

ASCO Valves



**MANUAL OPERATOR DISASSEMBLY AND REASSEMBLY** (Refer to Figures 1 & 2)

**For 3/4 inch N.P.T. Valves:** Unscrew bonnet, remove gasket and stem pin. Unscrew stem from bonnet and remove stem gasket. Reassemble in reverse order of disassembly paying careful attention to exploded view provided for identification and placement of parts.

**For 1 inch N.P.T. Valves:** Unscrew stuffing box and remove stuffing box gasket. Remove knob pin using a suitable punch. Remove knob, spring, stem, stem gasket and stem guide. Reassemble in reverse order of disassembly paying careful attention to exploded view provided for identification and placement of parts.

**SPARE PARTS KITS**

Spare Parts Kits and Coils are available for ASCO valves. Parts marked with an asterisk (\*) are supplied in Spare Parts Kits.

**ORDERING INFORMATION FOR SPARE PARTS KITS**  
When Ordering Spare Parts Kits or Coils Specify Valve Catalog Number, Serial Number and Voltage.

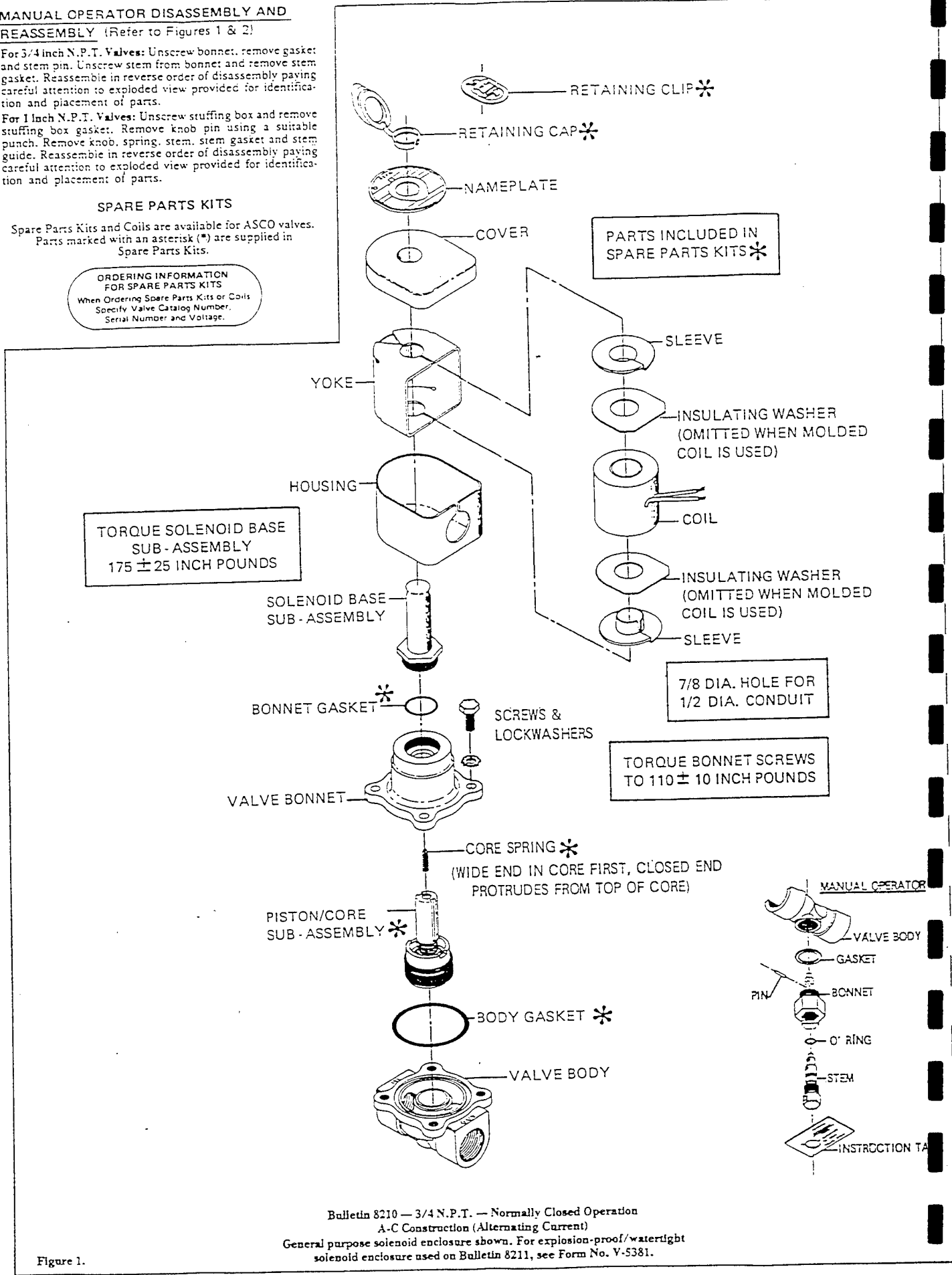
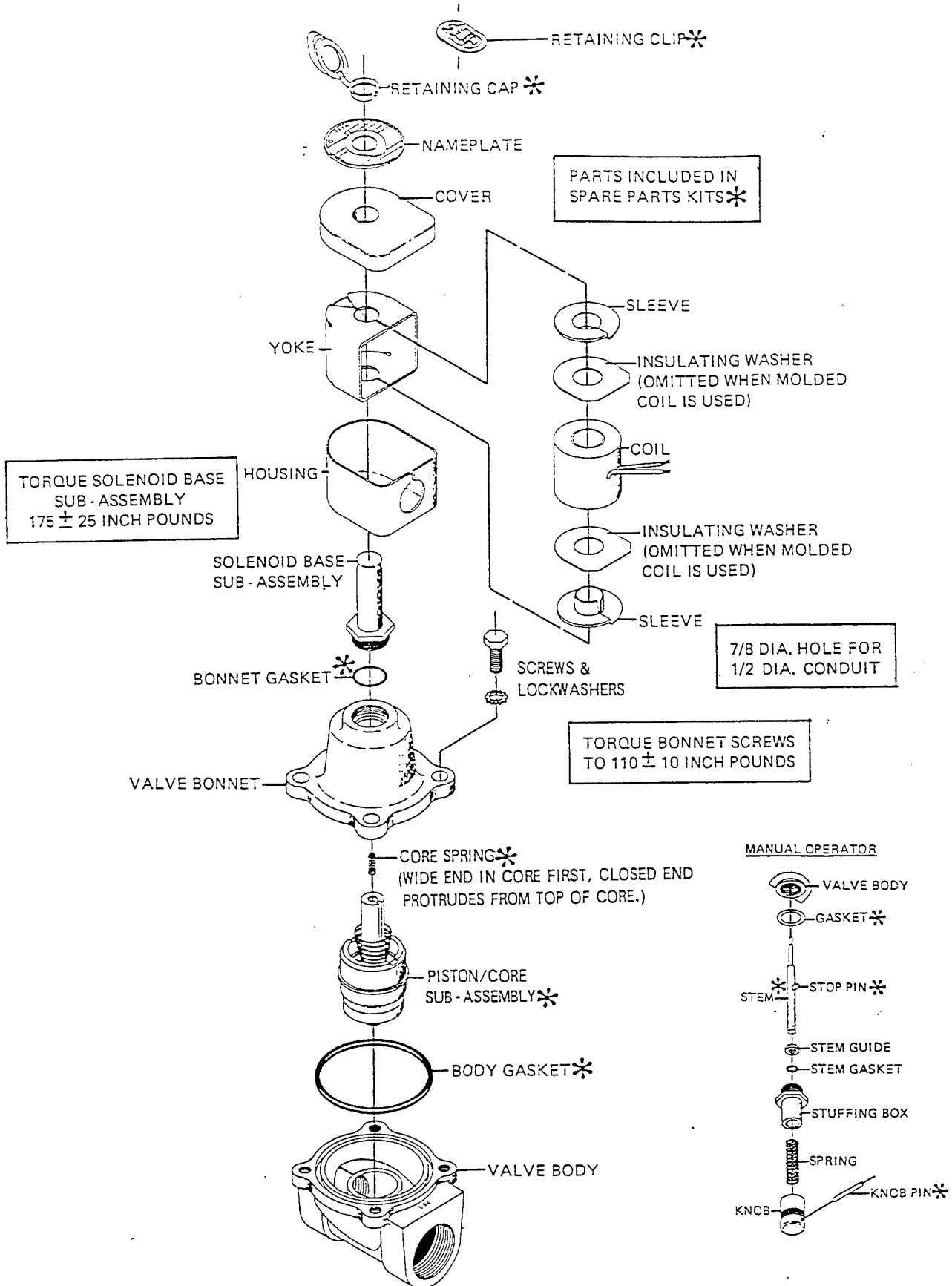

Figure 1.

Bulletin 8210 — 3/4 N.P.T. — Normally Closed Operation  
A-C Construction (Alternating Current)  
General purpose solenoid enclosure shown. For explosion-proof/watertight solenoid enclosure used on Bulletin 8211, see Form No. V-5381.



Bulletin 8210 — 1 Inch N.P.T. — Normally Closed Operation  
 A-C Construction (Alternating Current)  
 General purpose solenoid enclosure shown. For explosion-proof/watertight  
 solenoid enclosure used on Bulletin 8211, see Form No. V-5381.

Figure 2.

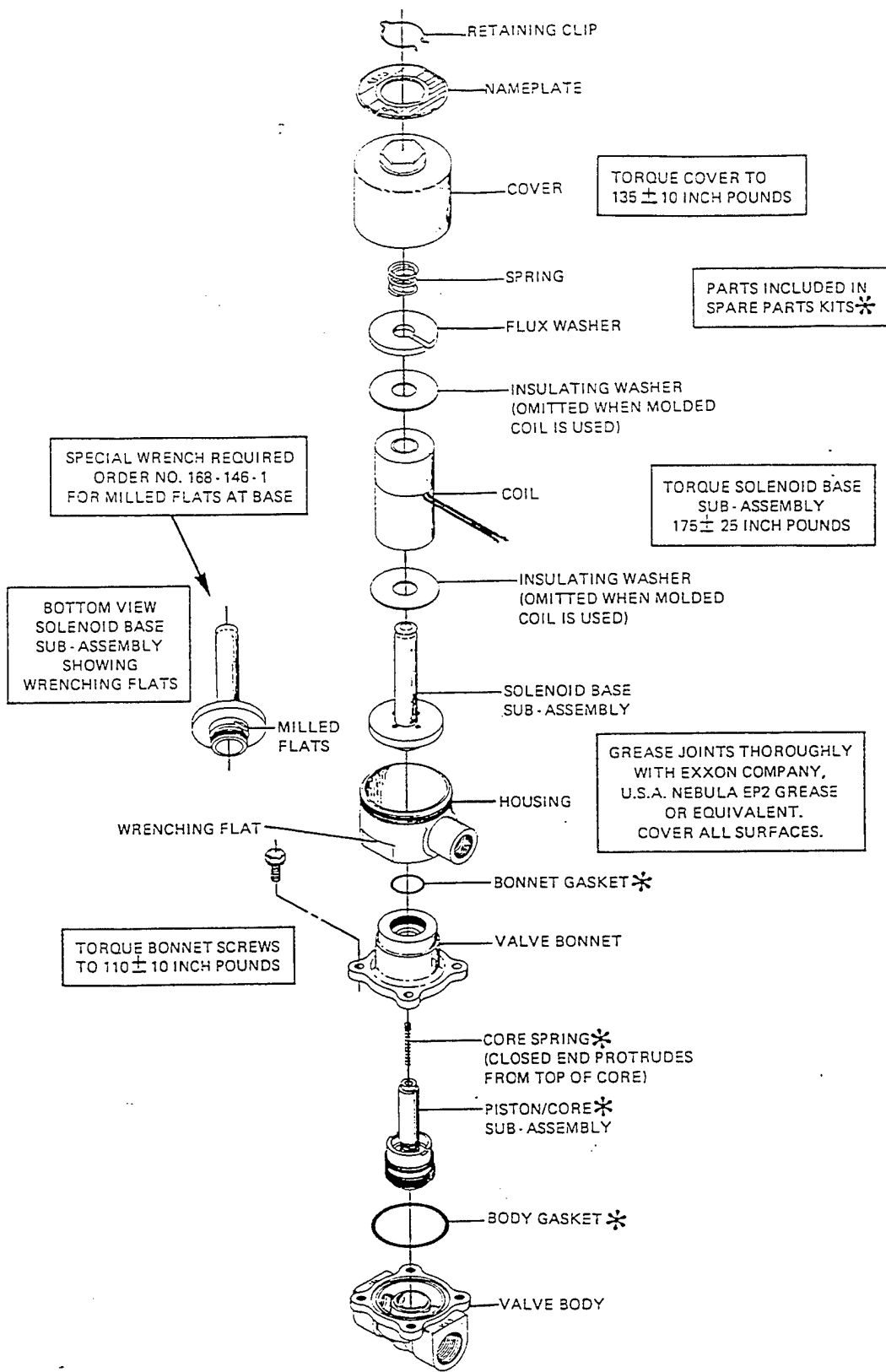

Bulletins 8210 and 8211 — 3/4 N.P.T. — Normally Closed Operation  
 D-C Construction (Direct Current)  
 Solenoid enclosure shown is used for general purpose and explosion-proof/watertight.  
 For explosion-proof/watertight requirements, see note under "Coil Replacement".

Figure 3.

# INSTALLATION AND MAINTENANCE INSTRUCTIONS

2-WAY INTERNAL PILOT OPERATED SOLENOID VALVES  
HUNG DIAPHRAGM - 1/2 AND 3/4 N.P.T.  
NORMALLY CLOSED OPERATION

BULLETINS

8210

8211



## DESCRIPTION

Bulletin 8210's are 2-way normally closed, internal pilot operated solenoid valves. Valves are of stainless steel construction. Standard valves have a General Purpose, NEMA Type 1 Solenoid Enclosure.

Bulletin 8211's are the same as Bulletin 8210's except the solenoids are equipped with an enclosure which is designed to meet NEMA Type 4 Watertight, NEMA Type 7 (C or D) Hazardous Locations - Class I, Group C or D, and NEMA Type 9 (E, F or G) Hazardous Locations - Class II, Group E, F or G. The explosion-proof/watertight solenoid enclosure is shown on a separate sheet of Installation and Maintenance Instructions, Form No. V-5380.

## OPERATION

Normally Closed: Valve is closed when solenoid is de-energized and opens when solenoid is energized.

## MANUAL OPERATOR (Optional)

Valves with suffix 'MO' in catalog number are provided with a manual operator which allows manual operation when desired or during an interruption of electrical power. To operate valve manually, rotate stem clockwise 180°. Disengage manual operator by rotating stem counterclockwise 180° before operating electrically.

## INSTALLATION

Check nameplate for correct catalog number, pressure, voltage and service.

## TEMPERATURE LIMITATIONS

For maximum valve ambient and fluid temperatures refer to chart below. The temperature limitations listed are for UL applications. For non UL applications, higher ambient and fluid temperature limitations are available. Consult factory. Check catalog number on nameplate to determine maximum temperatures.

Construction	Coil Class	Catalog Number Prefix	Maximum Ambient Temp. °F	Maximum Fluid Temp. °F
A-C Construction (Alternating Current)	F	None	77	175
D-C Construction (Direct Current)	A, F or H	None, FT or HT	77	150

## POSITIONING/MOUNTING

Valve may be mounted in any position. For mounting bracket (optional feature) dimensions, refer to Figure 1.

## PIPING

Connect piping to valve according to markings on valve body. Apply pipe compound sparingly to male pipe threads only; if applied to valve threads, it may enter the valve and cause operational difficulty. Pipe strain should be avoided by proper support and alignment of piping. When tightening the pipe do not use valve as a lever. Wrenches applied to valve body or piping are to be located as close as possible to connection point.

**IMPORTANT:** For the protection of the solenoid valve, install a strainer or filter suitable for the service involved in the inlet side as close to the valve as possible. Periodic cleaning is required depending on the service conditions. See Bulletins 8600, 8601 and 8602 for strainers.

## WIRING

Wiring must comply with Local and National Electrical Codes. Housings for all solenoids are provided with connections for 1/2 inch conduit. The general purpose solenoid enclosure may be rotated to facilitate wiring by removing the retaining cap or clip. **CAUTION:** When metal retaining clip disengages it will spring upwards. Rotate to desired position. Replace retaining cap or clip before operating.

**NOTE:** Alternating Current (A-C) and Direct Current (D-C) Solenoids are built differently. To convert from one to the other, it is necessary to change the complete solenoid including the solenoid base sub-assembly and core assembly.

## SOLENOID TEMPERATURE

Standard catalog valves are supplied with coils designed for continuous duty service. When the solenoid is energized for a long period, the solenoid enclosure becomes hot and can be touched with the hand for only an instant. This is a safe operating temperature. Any excessive heating will be indicated by the smoke and odor of burning coil insulation.

## MAINTENANCE

**WARNING:** Turn off electrical power and depressurize valve before making repairs. It is not necessary to remove valve from pipe line for repairs.

## CLEANING

A periodic cleaning of all solenoid valves is desirable. The time between cleanings will vary, depending on media and service conditions. In general, if the voltage to the coil is correct, sluggish valve operation, excessive leakage or noise will indicate that cleaning is required.

ASCO Valves



## PREVENTIVE MAINTENANCE

1. Keep the medium flowing through the valve as free from dirt and foreign material as possible.
2. While in service, operate the valve at least once a month to insure proper opening and closing.
3. Periodic inspection (depending on media and service conditions) of internal valve parts for damage or excessive wear is recommended. Thoroughly clean all parts. Replace any parts that are worn or damaged.

## IMPROPER OPERATION

1. **Faulty Control Circuit:** Check electrical system by energizing solenoid. A metallic click signifies the solenoid is operating. Absence of the click indicates loss of power supply. Check for loose or blown-out fuses, open circuited or grounded coil, broken lead wires or splice connections.
2. **Burned-Out Coil:** Check for open circuited coil. Replace coil if necessary.
3. **Low Voltage:** Check voltage across coil leads. Voltage must be at least 85% of nameplate rating.
4. **Incorrect Pressure:** Check valve pressure. Pressure to the valve must be within range specified on nameplate.
5. **Excessive Leakage:** Disassemble valve and clean all parts. Replace worn or damaged parts with a complete Spare Parts Kit for best results.

## COIL REPLACEMENT (Refer to Figure 2)

Turn off electrical power and disconnect coil lead wires. Proceed in the following manner:

1. Remove retaining cap or clip, nameplate and cover. **CAUTION:** When metal retaining clip disengages, it will spring upwards.
2. Slip spring washer, insulating washer and coil off solenoid base sub-assembly. Insulating washers are omitted when a molded coil is used.
3. Reassemble in reverse order of disassembly paying careful attention to exploded views provided for identification and placement of parts.

**CAUTION:** Solenoid must be fully reassembled as the housing and internal parts are part of and complete the magnetic circuit. Place insulating washers at each end of the coil if required.

## VALVE DISASSEMBLY AND REASSEMBLY (Refer to Figures 2 & 3)

Depressurize valve and turn off electrical power supply. Proceed in the following manner:

**NOTE:** For valves with a manual operator (Suffix M.O. in catalog number) refer to Figure 3. For standard valves refer to Figure 2.

1. Remove retaining cap or clip and slip the entire solenoid enclosure off the solenoid base sub-assembly. **CAUTION:** When metal retaining clip disengages, it will spring upwards.
2. Unscrew the solenoid base sub-assembly and remove bonnet gasket. For valves with a manual operator unscrew manual operator body and remove stem retainer, manual operator stem sub-assembly, stem gasket and bonnet gasket.
3. Remove bonnet screws (4), valve bonnet, core spring, core/diaphragm sub-assembly and body gasket. **CAUTION:** Do not damage or distort hanger spring between core/diaphragm sub-assembly.
4. All parts are now accessible for cleaning or replacement. Replace worn or damaged parts with a complete Spare Parts Kit for best results.
5. Reassemble in reverse order of disassembly paying careful attention to exploded views provided for identification and placement of parts.
6. Replace body gasket and core/diaphragm sub-assembly locating the bleed hole in the diaphragm assembly approximately 45° from the valve outlet.
7. Replace valve bonnet and bonnet screws (4). Torque bonnet screws (4) in a crisscross manner to  $110 \pm 10$  inch pounds.
8. Insert core spring in core, wide end of core spring in core first, closed end protrudes from top of core.
9. Replace bonnet gasket and solenoid base sub-assembly. Torque solenoid base sub-assembly to  $175 \pm 25$  inch pounds.

10. For valves with a manual operator, replace stem gasket and manual operator stem sub-assembly in manual operator body.
11. Replace stem retainer on manual operator body. Be sure that the captive washer on manual operator stem sub-assembly is on the outside of stem retainer when assembled.
12. Replace bonnet gasket, manual operator body, bonnet gasket and solenoid base sub-assembly. Torque manual operator body and solenoid base sub-assembly to  $175 \pm 25$  inch pounds.
13. Replace solenoid enclosure and retaining cap or clip.
14. After maintenance, operate the valve a few times to be sure of proper opening and closing.

## SPARE PARTS KITS

Spare Parts Kits and Coils are available for ASCO valves. Parts marked with an asterisk (\*) are supplied in Spare Parts Kits.

### ORDERING INFORMATION FOR SPARE PARTS KITS

When Ordering Spare Parts Kits or Coils Specify Valve Catalog Number, Serial Number and Voltage.

### PARTIAL VIEW OF MOUNTING BRACKET (OPTIONAL)

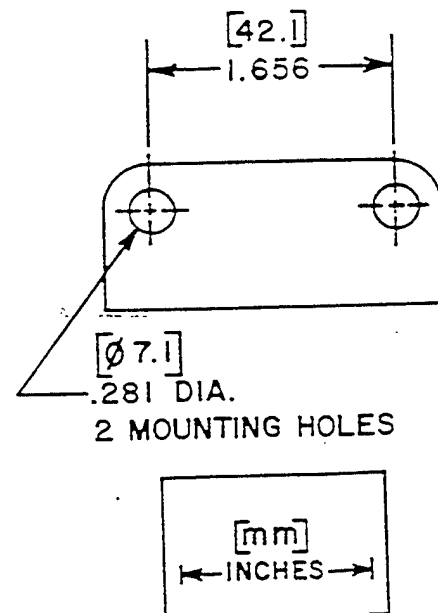

Figure 1.

Dimensions For Mounting Bracket (Optional Feature)



ASCO Valves  
Automatic Switch Co.

FLORHAM PARK, NEW JERSEY 07932

Form No. V-5827

PRINTED IN U.S.A.

71

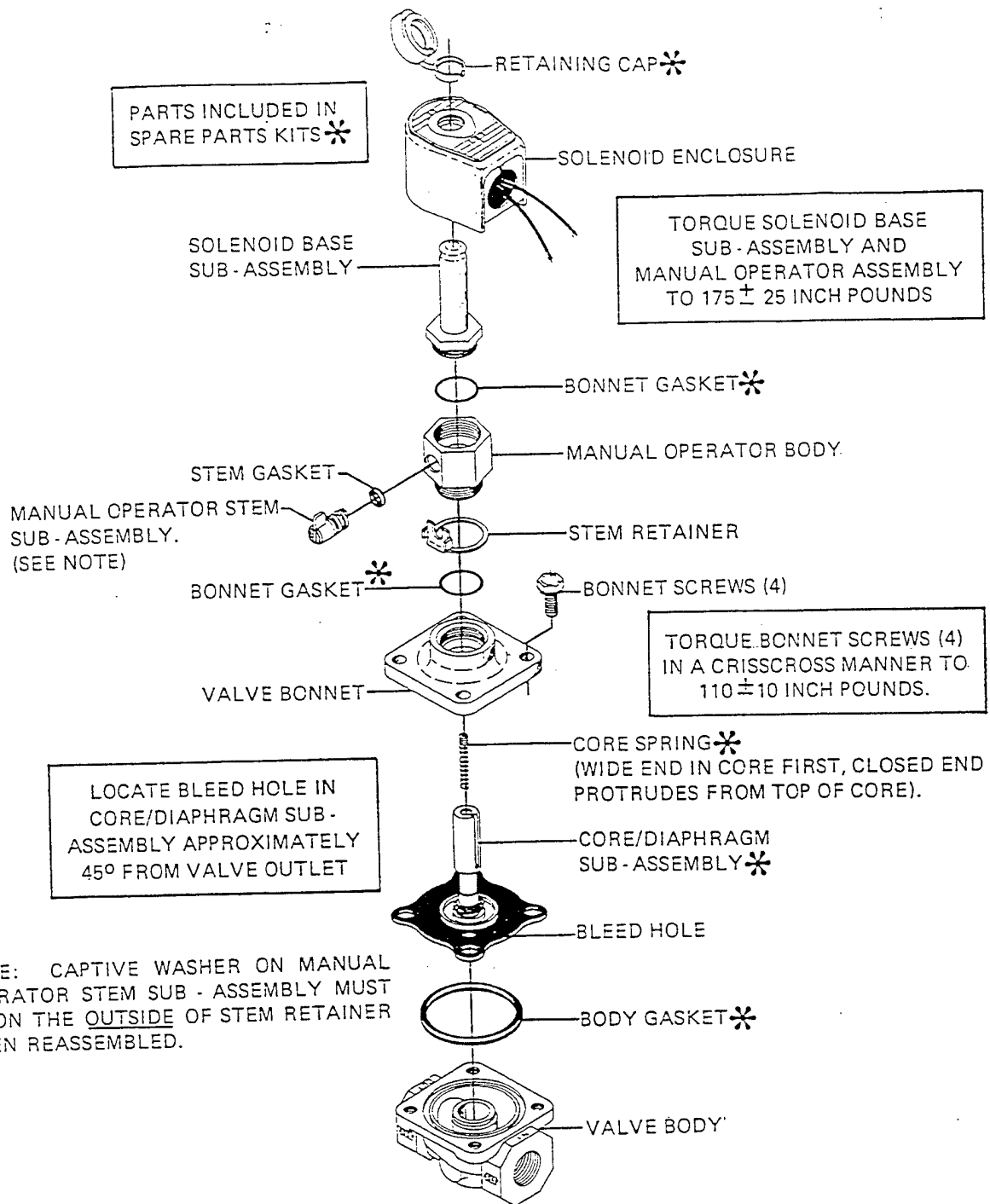
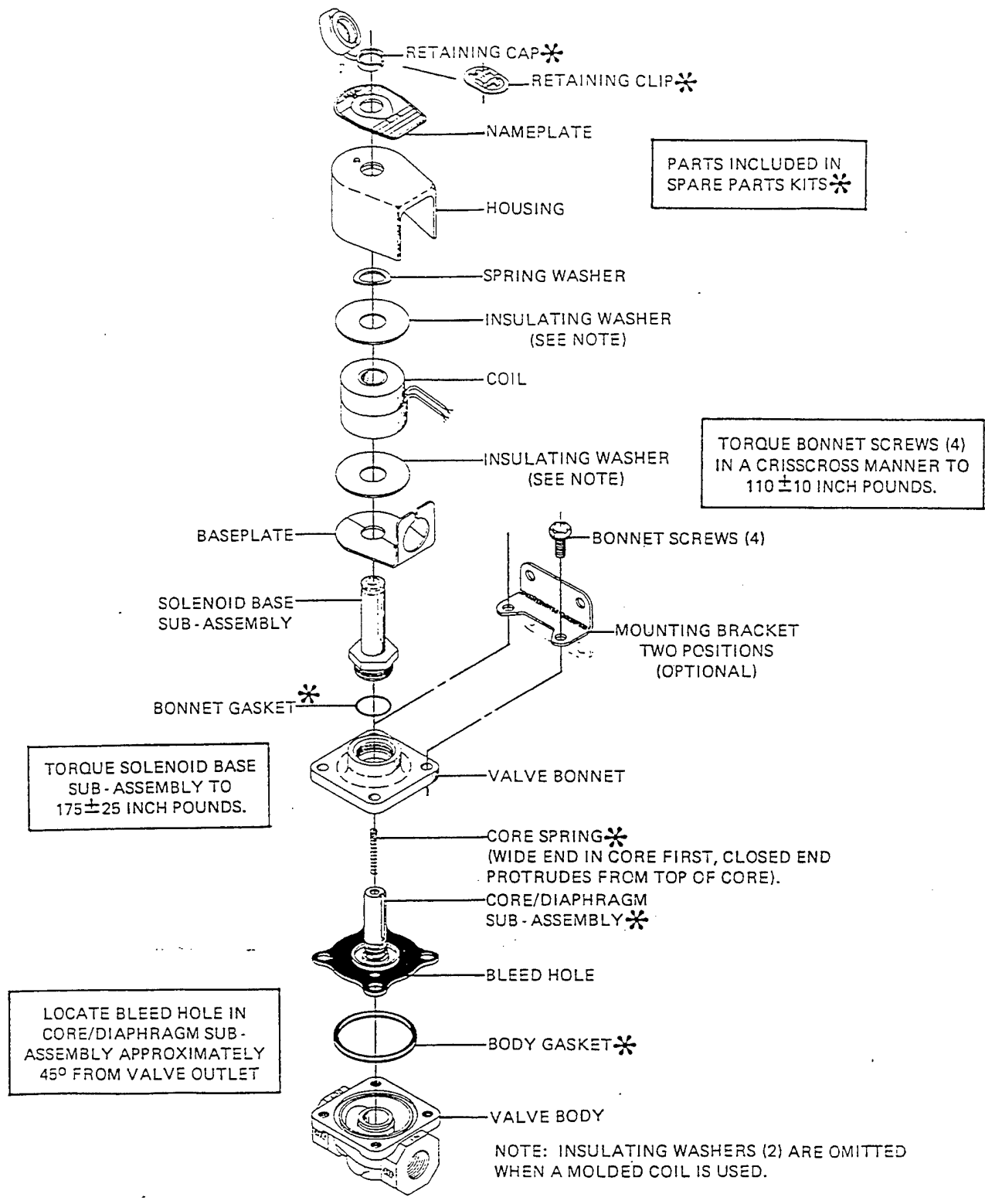

Figure 3.

Bulletin 8210 — Manual Operator  
 (Catalog No. with Suffix M.O.) General purpose solenoid enclosure shown.  
 For explosion-proof/watertight solenoid enclosure used on Bulletin 8211, see Form No. V-5380.





Bulletin 8210 — 1/2 & 3/4 N.P.T.  
 General purpose solenoid enclosure shown.

Figure 2.

For explosion-proof/watertight solenoid enclosure used on Bulletin 8211, see Form No. V-5380.

Fisher Controls

Instruction Manual

## 627 Series Self-Operated Pressure Reducing Regulators



January 1987

Form 5252

### Introduction

#### Scope of Manual

This manual provides instructions for the installation, adjustment, maintenance, and parts ordering for the 627 Series regulators. These regulators usually are shipped separate for line installation, although sometimes they are shipped installed on other equipment. Refer to the instruction manual for the other equipment for installation and operating instructions.

### Description

The Fisher 627 Series self-operated pressure reducing regulators (figure 1) are for high and low pressure systems. These regulators can be used with natural gas, air, or a variety of other gases. Performance characteristics vary according to construction (see the AVAILABLE CONFIGURATIONS specification in table 1).

### Specifications

Table 1 gives some general specifications for the 627 Series regulators. The nameplates (figure 2) gives detailed information for a particular regulator as it comes from the factory.

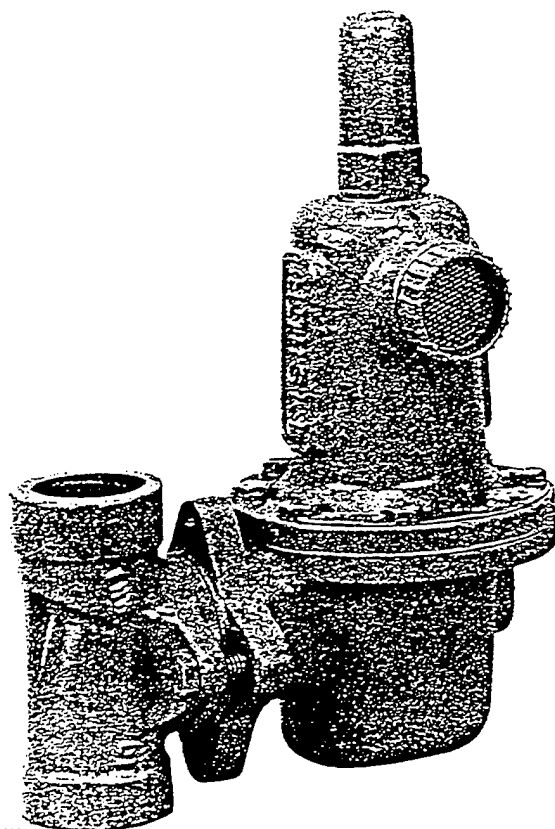

Figure 1. Typical 627 Series Self-Operated Pressure Reducing Regulator

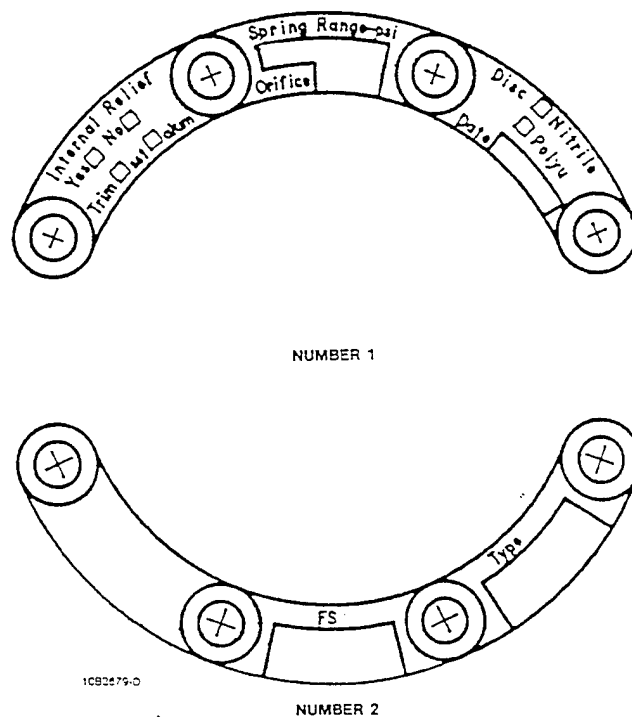

Figure 2. Nameplates

Table 1. Specifications

AVAILABLE CONSTRUCTIONS	<p>Type 627: Self-operated pressure reducing regulator equipped with a pitot tube for greater regulated capacities (figure 7)</p> <p>Type 627R: Type 627 with internal relief and with an open throat (figure 8)</p> <p>Type 627M: Type 627 with a stem seal between the body outlet pressure and diaphragm case. Pressure is measured under the diaphragm through the 1/4-inch NPT downstream control line connection (figure 9)</p> <p>Type 627MR: Type 627M with internal relief (figure 10)</p>	MAXIMUM BODY OUTLET PRESSURE <sup>(1)</sup> (TYPE 627M AND 627MR ONLY)	2000 psig (138 bar) for screwed steel, 1480 psig (102 bar) for RF flanged steel, or 1000 psig (69 bar) for ductile iron. (Type 627 and 627R are limited by maximum diaphragm casing pressure)
BODY SIZES	3/4, 1, or 2-inch	PORT DIAMETERS	See table 2
END CONNECTION STYLES	<p>NPT screwed with 3/4, 1, or 2-inch sizes</p> <p>ANSI Class 600 raised face (RF) flanged with 1 or 2-inch sizes</p>	INTERNAL RELIEF PERFORMANCE	<p>Type 627R: See table 3</p> <p>Type 627MR: Limited by field-installed control line piping</p>
MAXIMUM INLET PRESSURE <sup>(1)</sup> (BODY RATING)	2000 psig (138 bar) for screwed steel, 1480 psig (102 bar) for RF flanged steel, or 1000 psig (69 bar) for ductile iron	TEMPERATURE CAPABILITIES <sup>(1)</sup>	- 20 to 180°F (- 29 to 82°C)
MAXIMUM VALVE DISK INLET PRESSURE RATING <sup>(1)</sup>	2000 psig (138 bar) for polyurethane disk or 1000 psig (69 bar) for nitrile disk	PRESSURE REGISTRATION	<p>Type 627 or 627R: Internal</p> <p>Type 627M or 627MR: External through 1/4-inch NPT control line connection in the diaphragm casing</p>
MAXIMUM INLET AND OUTLET PRESSURE RANGES <sup>(1)</sup>	See table 2 for pressures by port and spring range	DE-ICER SYSTEM	See figure 3 and Type 627M Regulator De-Icer System Application section
MAXIMUM DIAPHRAGM CASING PRESSURE <sup>(1)</sup>	250 psig (17.2 bar) for ductile iron and aluminum	RELIEF INDICATOR	For 627R and 627MR (see figure 4)
		SPRING CASE VENT CONNECTION	3/4-inch NPT female with removable screened vent assembly
		CONTROL LINE CONNECTION (TYPE 627M OR 627MR ONLY)	1/4-inch NPT female
		APPROXIMATE WEIGHT	<p>With Ductile Iron or Steel Casings: 10 pounds (4.5 kg)</p> <p>With Aluminum Casings: 6.3 pounds (2.8 kg)</p>
<p>1. The pressure/temperature limits in this bulletin and any applicable standard or code limitation should not be exceeded.</p>			

**WARNING**

Personal injury, property damage, equipment damage, or leakage due to escaping gas or bursting of pressure-containing parts may result if this regulator is over-pressured or is installed where service conditions could exceed the limits given in tables 1, 2, and 3, or where conditions exceed any ratings of the adjacent piping or piping connections

To avoid such injury or damage, provide pressure-relieving or pressure-limiting devices (as required by the appropriate code, regulation, or standard) to prevent service conditions from exceeding those limits. The Type 627R or 627MR regulator with internal relief will provide downstream overpressure protection within the limits given in tables 1, 2, and 3. If these limits are exceeded additional downstream over pressure protection must be provided by the user.

Table 2. Maximum Inlet Pressures and Outlet Pressure Ranges

TYPE NUMBER	OUTLET PRESSURE RANGE AND CONTROL SPRING (COLOR)	U.S. UNITS		METRIC UNITS		TYPE NUMBER	OUTLET PRESSURE RANGE AND CONTROL SPRING (COLOR)	U.S. UNITS		METRIC UNITS	
		Port Dia., Inches	Maximum Inlet Pressure, Psig	Port Dia., mm	Maximum Inlet Pressure, Bar			Port Dia., Inches	Maximum Inlet Pressure, Psig	Port Dia., mm	Maximum Inlet Pressure, Bar
627 and 627M	10 to 20 psig (0.69 to 1.4 bar) 10B3076 X012 (yellow)	3/32	2000 <sup>(1)</sup>	2.4	138 <sup>(1)</sup>	627R and 627MR	10 to 20 psig (0.69 to 1.4 bar) 10B3076 X012 (yellow)	3/32	2000 <sup>(1)</sup>	2.4	138 <sup>(1)</sup>
		1/8	1000	3.2	69.0			1/8	1000	3.2	69.0
		3/16	750	4.8	51.7			3/16	750	4.8	51.7
		1/4	500	6.4	34.5			1/4	500	6.4	34.5
		3/8	300	9.5	20.7			3/8	300	9.5	20.7
	1/2	250	12.7	13.8	1/2		200	12.7	13.8		
	15 to 40 psig (1.0 to 2.8 bar) 10B3077 X012 (green)	3/32	2000 <sup>(1)</sup>	2.4	138 <sup>(1)</sup>		15 to 40 psig (1.0 to 2.8 bar) 10B3077 X012 (green)	3/32	2000 <sup>(1)</sup>	2.4	138 <sup>(1)</sup>
		1/8	1500 <sup>(1)</sup>	3.2	103 <sup>(1)</sup>			1/8	1500 <sup>(1)</sup>	3.2	103 <sup>(1)</sup>
		3/16	1000 <sup>(1)</sup>	4.8	69.0			3/16	1000	4.8	69.0
		1/4	750	6.4	51.7			1/4	750	6.4	51.7
		3/8	500	9.5	34.5			3/8	300	9.5	20.7
	1/2	300	12.7	20.7	1/2		200	12.7	13.8		
	35 to 80 psig (2.4 to 5.5 bar) 10B3078 X012 (blue)	3/32	2000 <sup>(1)</sup>	2.4	138 <sup>(1)</sup>		35 to 80 psig (2.4 to 5.5 bar) 10B3078 X012 (blue)	3/32	2000 <sup>(1)</sup>	2.4	138 <sup>(1)</sup>
		1/8	2000 <sup>(1)</sup>	3.2	138 <sup>(1)</sup>			1/8	1750 <sup>(1)</sup>	3.2	121 <sup>(1)</sup>
		3/16	1750 <sup>(1)</sup>	4.8	121 <sup>(1)</sup>			3/16	1000	4.8	69.0
		1/4	1500 <sup>(1)</sup>	6.4	103 <sup>(1)</sup>			1/4	750	6.4	51.7
3/8		1000	9.5	69.0	3/8	300		9.5	20.7		
1/2	750	12.7	51.7	1/2	200	12.7	13.8				
70 to 150 psig (4.8 to 10.3 bar) 10B3079 X012 (red)	3/32	2000 <sup>(1)</sup>	2.4	138 <sup>(1)</sup>	70 to 150 psig (4.8 to 10.3 bar) 10B3079 X012 (red)	3/32	2000 <sup>(1)</sup>	2.4	138 <sup>(1)</sup>		
	1/8	2000 <sup>(1)</sup>	3.2	138 <sup>(1)</sup>		1/8	1000	3.2	69.0		
	3/16	2000 <sup>(1)</sup>	4.8	138 <sup>(1)</sup>		3/16	500	4.8	34.5		
	1/4	1750 <sup>(1)</sup>	6.4	121 <sup>(1)</sup>		1/4	300	6.4	20.7		
	3/8	1250 <sup>(1)</sup>	9.5	86.2 <sup>(1)</sup>		3/8	200	9.5	13.8		
1/2	750	12.7	51.7	1/2	200	12.7	13.8				

1. For inlet pressure in excess of 1000 psig (69 bar), refer to the maximum body and disk pressure ratings in the specification table.

Additionally, physical damage to the regulator could cause personal injury or property damage due to escaping gas. To avoid such injury or damage, install the regulator in a safe location.

## Installation

Regulator operation within ratings does not preclude the possibility of damage from debris in the lines or from external sources. A regulator should be inspected for damage periodically and after any overpressure condition. Key numbers referenced in this section are shown in figures 7 through 10. Ensure that the operating temperature capabilities listed in table 1 are not exceeded.

Like most regulators, 627 Series regulators have outlet pressure ratings that are lower than their inlet pressure ratings. A pressure relieving or pressure limiting device must be provided by the user for the Type 627 and 627M regulators if the inlet the pressure can exceed the outlet pressure rating, since these regulators do not have internal relief.

Type 627R regulators provide internal relief which limits the total outlet pressure buildup over setpoint. Use table

3 to determine the total outlet pressure. This internal relief may be adequate for the application, if not, provide additional pressure relief or a pressure limiting device downstream.

## Note

If the regulator is shipped mounted on another unit, install that unit according to the appropriate instruction manual.

Perform steps 1 through 6 for all types of regulators:

1. Only personnel qualified through training and experience should install, operate, or maintain this regulator.
2. For a regulator that is shipped separately, make sure that there is no damage to, or foreign material in, the regulator.
3. Ensure that all tubing and piping have been blown free of foreign debris.
4. The regulator may be installed in any position as long as the flow through the body is in the direction indicated by the arrow cast on the body.

Table 3. Type 627R Internal Relief Performance<sup>(1)</sup>

OUTLET PRESSURE RANGE AND CONTROL SPRING INFORMATION	OUTLET PRESSURE SETTING, PSIG	MAXIMUM ALLOWABLE DOWNSTREAM SYSTEM PRESSURE, PSIG	MAXIMUM INLET PRESSURE <sup>(2)</sup> - PSIG							OUTLET PRESSURE SETTING, BAR	MAXIMUM ALLOWABLE DOWNSTREAM SYSTEM PRESSURE, BAR	MAXIMUM INLET PRESSURE <sup>(2)</sup> - BAR					
			Maximum Inlet Pressure To Keep Maximum Allowable Downstream System Pressure From Being Exceeded									Maximum Inlet Pressure To Keep Maximum Allowable Downstream System Pressure From Being Exceeded					
			Port Diameter - Inches									Port Diameter - mm					
			3/32	1/8	3/16	1/4	3/8	1/2	2.4			3.2	4.8	6.4	9.5	12.7	
10 to 20 psig (0.69 to 1.4 bar) 10B3076 X012 (yellow)	10	60	1250	740	320	190	95	75	0.69	4.1	86.2	51.0	22.1	13.1	6.6	5.2	
		100	2000	1500	620	390	180	130		6.9	138	103	42.7	26.9	12.4	9.0	
		125	2000	1900	830	480	220	160		8.6	138	131	57.2	33.1	15.2	11.0	
		175	2000	2000	1100	670	320	220		12.1	138	138	75.8	46.2	22.1	15.2	
		200	2000	2000	1300	770	360	260		13.8	138	138	89.6	53.1	24.8	17.9	
		250	2000	2000	1600	960	450	320		17.2	138	138	110	66.2	31.0	22.1	
	15	60	1000	620	260	170	90	70	1.0	4.1	69.0	42.7	17.9	11.7	6.2	4.8	
		100	2000	1400	610	370	170	130		6.9	138	96.5	42.1	25.5	11.7	9.0	
		125	2000	1900	810	480	220	160		8.6	138	131	55.8	33.1	15.2	11.0	
		175	2000	2000	1100	670	320	220		12.1	138	138	75.8	46.2	22.1	15.2	
		200	2000	2000	1300	770	360	260		13.8	138	138	89.6	53.1	24.8	17.9	
		250	2000	2000	1600	960	450	320		17.2	138	138	110	66.2	31.0	22.1	
	20	60	850	490	210	130	80	65	1.4	4.1	58.6	33.8	14.5	9.0	5.5	4.6	
		100	2000	1300	600	360	170	120		6.9	138	89.6	41.4	24.8	11.7	8.3	
		125	2000	1800	800	480	220	160		8.6	138	124	55.2	33.1	15.2	11.0	
175		2000	2000	1100	670	320	220	12.1		138	138	75.8	46.2	22.1	15.2		
200		2000	2000	1300	770	360	260	13.8		138	138	89.6	53.1	24.8	17.9		
250		2000	2000	1600	960	450	320	17.2		138	138	110	66.2	31.0	22.1		
15 to 40 psig (1.0 to 2.8 bar) 10B3077 X012 (green)	15	60	1000	380	210	130	80	65	1.0	4.1	69.0	26.2	14.5	9.0	5.5	4.5	
		100	2000	1300	590	350	170	120		6.9	138	89.6	40.7	24.1	11.7	8.3	
		125	2000	1800	800	470	220	160		8.6	138	124	55.2	32.4	15.2	11.0	
		175	2000	2000	1100	640	320	220		12.1	138	138	75.8	44.1	22.1	15.2	
		200	2000	2000	1300	780	370	260		13.8	138	138	89.6	53.8	25.5	17.9	
		250	2000	2000	1600	960	450	320		17.2	138	138	110	66.2	31.0	22.1	
	20	60	630	200	150	100	70	65	1.4	4.1	43.4	13.8	10.3	6.9	4.8	4.5	
		100	2000	1200	550	330	160	120		6.9	138	82.7	37.9	22.8	11.0	8.3	
		125	2000	1700	760	450	210	160		8.6	138	117	52.4	31.0	14.5	11.0	
		175	2000	2000	1100	630	320	220		12.1	138	138	75.8	43.4	22.1	15.2	
		200	2000	2000	1300	770	360	260		13.8	138	138	89.6	53.1	24.8	17.9	
		250	2000	2000	1600	960	460	320		17.2	138	138	110	66.2	31.7	22.1	
	30	100	2000	950	450	260	140	110	2.1	6.9	138	65.5	31.0	17.9	9.7	7.6	
		125	2000	1500	670	400	190	150		8.6	138	103	46.2	27.6	13.1	10.3	
		175	2000	2000	1000	610	300	220		12.1	138	138	69.0	42.0	20.7	15.2	
		200	2000	2000	1200	760	360	260		13.8	138	138	82.7	52.4	24.8	17.9	
		250	2000	2000	1600	970	460	320		17.2	138	138	110	66.9	31.7	22.1	
		40	100	1500	700	330	200	120		108	2.8	6.9	103	48.3	22.8	13.8	8.3
	125		2000	1300	560	340	180	140	8.6	138		89.6	38.6	23.4	12.4	9.7	
	175		2000	1800	1000	550	290	220	12.1	138		124	69.0	37.9	20.0	15.2	
	200		2000	2000	1200	730	350	250	13.8	138		138	82.7	50.3	24.1	17.2	
	250		2000	2000	1600	970	460	320	17.2	138		138	110	66.9	31.7	22.1	

- Continued -

5. If continuous operation is required during inspection or maintenance, install a three-valve bypass around the regulator.

**WARNING**

A regulator may vent some gas to the atmosphere. In hazardous or flammable gas ser-

vice, vented gas may accumulate and cause personal injury, death, or property damage due to fire or explosion. Vent a regulator in hazardous gas service to a remote, safe location away from air intakes or any hazardous area. The vent line or stack opening must be protected against condensation or clogging.

Table 3. Type 627R Internal Relief Performance<sup>(1)</sup> (Continued)

OUTLET PRESSURE RANGE AND CONTROL SPRING INFORMATION	OUTLET PRESSURE SETTING, PSIG	MAXIMUM ALLOWABLE DOWNSTREAM SYSTEM PRESSURE, PSIG	MAXIMUM INLET PRESSURE <sup>(2)</sup> - PSIG						OUTLET PRESSURE SETTING, BAR	MAXIMUM ALLOWABLE DOWNSTREAM SYSTEM PRESSURE, BAR	MAXIMUM INLET PRESSURE <sup>(2)</sup> - BAR					
			Maximum Inlet Pressure To Keep Maximum Allowable Downstream System Pressure From Being Exceeded								Maximum Inlet Pressure To Keep Maximum Allowable Downstream System Pressure From Being Exceeded					
			Port Diameter - inches								Port Diameter - mm					
			3/32	1/8	3/16	1/4	3/8	1/2			2.4	3.2	4.8	6.4	9.5	12.7
35 to 80 psig (2.4 to 5.5 bar) 10B3078 X012 (blue)	40	125	2000	1100	500	300	170	140	2.8	8.6	138	75.8	34.5	20.7	11.7	9.7
		150	2000	1600	750	440	230	180		10.3	138	110	51.7	30.3	15.9	12.4
		175	2000	2000	980	580	290	220		12.1	138	138	67.6	40.0	20.0	15.2
		200	2000	2000	1200	720	340	250		13.8	138	138	82.7	49.6	23.4	17.2
		250	2000	2000	1600	940	450	320		17.2	138	138	110	64.8	31.0	22.1
	50	125	1400	820	400	230	150	140	3.4	8.6	96.5	56.5	27.6	15.9	10.3	9.7
		150	2000	1400	650	370	210	170		10.3	138	96.5	44.8	25.5	14.5	11.7
		175	2000	1900	700	530	270	210		12.1	138	131	48.3	36.5	18.6	14.5
		200	2000	2000	1100	670	330	240		13.8	138	138	75.8	46.2	22.8	16.5
		250	2000	2000	1500	920	430	320		17.2	138	138	103	63.4	29.6	22.1
	60	125	900	450	270	190	140	130	4.1	8.6	62.1	31.0	18.6	13.1	9.7	9.0
		150	1700	1100	540	300	190	160		10.3	117	75.8	37.2	20.7	13.1	11.0
		175	2000	1700	780	470	250	200		12.1	138	117	53.8	32.4	17.2	13.8
		200	2000	2000	1000	610	310	230		13.8	138	138	69.0	42.0	21.4	15.9
		250	2000	2000	1400	880	420	310		17.2	138	138	96.5	60.7	29.0	21.4
	70	150	1200	850	430	250	170	160	4.8	10.3	82.7	58.6	29.6	17.2	11.7	11.0
		175	2000	1400	670	400	230	190		12.1	138	96.5	46.2	27.6	15.9	13.1
		200	2000	2000	920	550	280	230		13.8	138	138	63.4	37.9	19.3	15.9
		250	2000	2000	1300	830	400	310		17.2	138	138	89.6	57.2	27.6	21.4
		150	800	500	300	200	160	150		5.5	10.3	55.2	34.5	20.7	13.8	11.0
175	1500	1200	550	330	210	190	12.1	103	82.7		37.9	22.8	14.5	13.1		
200	2000	1700	800	480	270	220	13.8	138	117		55.2	33.1	18.6	15.2		
250	2000	2000	1200	770	390	300	17.2	138	138		82.7	53.1	26.9	20.7		
70 to 150 psig (4.8 to 10.3 bar) 10B3079 X012 (red)	70	175	1900	600	400	260	200	175	4.8		12.1	131	41.4	27.6	17.9	13.8
		200	2000	1200	630	380	250	210		13.8	138	82.7	43.4	26.2	17.2	14.5
		250	2000	2000	1100	680	360	290		17.2	138	138	75.8	46.9	24.8	20.0
	80	175	1400	250	240	200	190	175	5.5	12.1	96.5	17.2	16.5	13.8	13.1	12.1
		200	2000	960	520	330	240	210		13.8	138	66.2	35.9	22.8	16.5	14.5
		250	2000	2000	1000	620	350	280		17.2	138	138	69.0	42.7	24.1	19.3
	100	200	1500	250	240	230	210	210	6.9	13.8	103	17.2	16.5	15.9	14.5	14.5
		250	2000	1600	770	320	320	270		17.2	138	110	53.1	35.9	22.1	18.6
	125	250	2000	1000	500	390	290	260	8.6	138	69.0	34.5	26.9	20.0	17.9	
	150	250	1200	260	260	260	260	260	4.8	17.2	82.7	17.9	17.9	17.9	17.9	17.9

1. The internal relief performance values were obtained by removing the disk assembly.  
 2. For inlet pressures in excess of 1000 psig (69 bar), refer to the maximum body and disk pressure ratings in the specification table.

Shaded areas indicate maximum inlet pressures allowed during system malfunction only. Table 1 gives the maximum inlet pressure for normal regulator operation.

6. Position the body (key 1) and/or diaphragm spring case (key 29) so it will not collect moisture or debris into the screened vent. If the regulator requires repositioning, refer to the body area maintenance procedures and/or the diaphragm case area maintenance procedures in the Maintenance section to reposition the screened vent for the application.

Perform steps 7 through 9 for Type 627M and 627MR regulators only:

7. A Type 627M or 627MR regulator requires a downstream control line. Install the control line before putting the regulator into operation.

8. Ensure that the downstream control line piping is at least 3/8-inch or larger outside diameter tubing and connected to a straight section of outlet piping 10 diameters downstream of the regulator.

9. A hand valve should be installed in the control line. This hand valve can be used to throttle down and dampen outlet pulsations in control pressure which may cause instability or cycling of the regulator.

### Remote Vent Line Installation

All regulators have a vent assembly installed in the 3/4-inch NPT spring case vent opening. The vent assembly

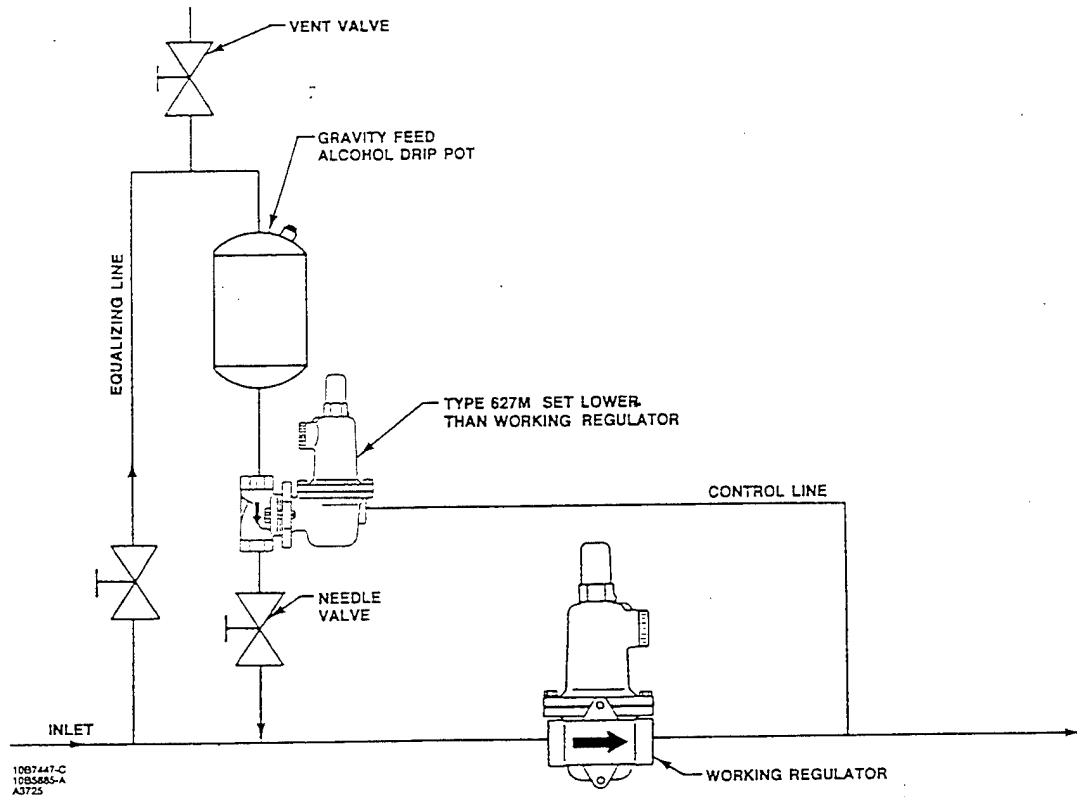

Figure 3. Schematic of De-Icer System

can be removed to install a remote vent line if necessary. Remote vent lines must have the largest practical diameter. The vent line should be as short as possible with a minimum number of bends or elbows.

Protect the remote vent opening against entrance of rain, snow, or any other foreign material that may plug the vent or vent line and prevent proper operation of the regulator. Periodically check the vent opening to be sure it is not plugged with foreign debris.

### Type 627M Regulator De-Icer System Application

For the Type 627M regulator de-icer system, refer to the application shown in figure 3. With a large pressure drop across the working regulator, ice can form within this regulator. The formation of ice decreases the size of the port opening, so the regulator is unable to supply enough flow to satisfy the downstream demand. When the downstream pressure falls below the outlet pressure setting of the Type 627M regulator, the disk assembly of the Type 627M regulator moves off its seat ring, permitting alcohol to flow into the main gas line. The alcohol carried to the main regulator by the flow stream prevents additional ice from forming on the seat ring.

When normal flow resumes, and as pressure in the downstream system is restored, the Type 627M regulator shuts off.

## Startup and Adjustment

### Startup

#### WARNING

To avoid personal injury or property damage due to explosion or damage to regulator or downstream components during startup, release downstream pressure to prevent an overpressure condition on the diaphragm of the regulator.

In order to avoid an overpressure condition and possible equipment damage, pressure gauges should always be used to monitor pressures during start-up.

Table 4. Maximum Torque Values

Key Number <sup>(1)</sup>	Description	Foot Pounds	Newton Meters
2	Seat ring	25	34
3	Cap screw (w/aluminum diaphragm casing)	16	22
3	Cap screw (w/ductile iron or steel diaphragm casing)	25	34
18, 37, and 46	Lever, spring case, and diaphragm cap screws	7	9
22	Diaphragm connector nut	17	23
26	Guide retainer (For Type 627R and 627MR only)	3	4

1. Refer to figures 7 through 10 for key number locations.

1. Slowly open the upstream shutoff valve.
2. Slowly open the downstream shutoff valve.
3. Check all connections for leaks.
4. Make final control spring adjustments according to the adjustment procedures.

### Adjustment

The range of allowable pressure settings is marked on the nameplate (figure 2). If a pressure setting beyond this range is necessary, substitute the appropriate regulator control spring. Change the nameplate to indicate the new pressure range.

Before increasing the setting, refer to table 2 or 3. Review the pressure limits for the control spring range being used and be certain that the new pressure setting will not result in an overpressure condition.

#### Note

**Always use a pressure gauge to monitor pressure when making adjustments.**

Refer to figures 7 through 10 for key number locations.

1. Remove the adjusting screw cap (key 36).
2. Loosen the locknut (key 34).
3. Increase the outlet pressure setting by turning the adjusting screw (key 35) clockwise. Decrease the outlet pressure setting by turning the adjusting screw counterclockwise.
4. When the desired pressure is obtained, hold the adjusting screw (key 35) in place and tighten the locknut (key 34).

### Shutdown

#### WARNING

To avoid personal injury or property damage due to explosion or damage to regulator or downstream components during shutdown, release downstream pressure to prevent an overpressure condition on the diaphragm of the regulator.

1. Close the nearest upstream shutoff valve.
2. Close the nearest downstream shutoff valve.
3. Open the vent valve between the regulator and the downstream shutoff valve nearest to it.
4. For a Type 627 or 627R regulator, the regulator will open to release pressure between the upstream shutoff valve and the regulator.
5. A Type 627M or 627MR regulator requires venting the control line and downstream pressure from the regulator before maintenance. The pressure between these shutoff valves is released through the open regulator because the disk assembly remains open in response to the decrease in control line pressure.

### Maintenance

Unless otherwise specified, the following maintenance procedures apply to all types of regulators. For a summary of maximum torque values required for all types of regulators, refer to table 4.

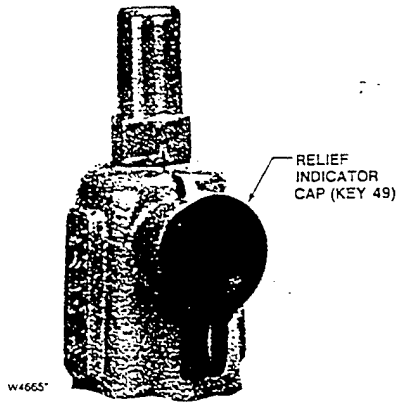

Figure 4. Relief Indicator

Due to normal wear, damage from external sources, or debris in the air or gas line, regulator parts such as the disk assembly, seat ring, and diaphragm must be inspected periodically and replaced as necessary to ensure correct performance. The frequency of inspection and replacement depends upon the severity of conditions and the requirements of state and federal laws. Normal wear of the seat ring and disk assembly is accelerated with high pressure drops and with large amounts of impurities in the flow stream. Instructions are given below for replacing the disk assembly, seat ring, diaphragm, and O-rings. These procedures may also be used for disassembly required for inspection and replacement of other parts.

### Problem Indication for Type 627R and 627MR Regulators

#### **WARNING**

Isolate the regulator from all pressure to avoid personal injury and equipment damage due to explosion or sudden release of process pressure. Cautiously release pressure from the regulator before attempting disassembly.

The vent assembly is equipped with a relief indicator (key 49, figure 4). The cap for the relief indicator snaps over the vent assembly opening. If the relief valve opens wide, exhaust gas pops the cap off the screen vent assembly opening indicating a problem with the regulator. If the cap pops off, refer to the shutdown and to the body area maintenance procedures to inspect the disk assembly and seat ring.

If the disk assembly and seat ring are not damaged, refer to the diaphragm and spring case area maintenance procedures in this section.

The disk assembly and seat ring can be inspected, removed, and replaced without removing the regulator body from the line connections. Refer to the body area maintenance procedures.

### Body Area Maintenance Procedures

These procedures are for gaining access to the disk assembly, seat ring, diaphragm casing O-ring and stem assembly. All pressure must be released from the diaphragm casing before the following steps can be performed.

While using the following procedures, refer to figures 7 through 10 for key number locations unless otherwise directed.

#### Replacing the Disk Assembly or Seat Ring

1. To inspect and replace the disk assembly (key 9) or seat ring (key 2), remove the cap screws (key 3, figure 5), and separate the diaphragm casing (key 5) from the body (key 1).
2. Inspect and, if necessary, remove the seat ring (key 2). If removed, coat the threads of the replacement seat ring with lubricant (key 38) and torque to 25 foot-pounds (34 N•m).
3. Inspect the disk assembly and, if necessary, remove the hair pin clip (key 13) that holds the disk assembly (key 9) in place. If replacing the disk assembly is the only maintenance required, skip to step 16.

#### Replacing the Stem Assembly

If it is necessary to perform maintenance on the stem assembly, continue with steps 4 through 8 and 15 through 19 for Type 627 and 627R regulators, or steps 9 through 19 for Type 627M and 627MR regulators.

#### Perform steps 4 through 8 for Type 627 and 627R Regulators only:

4. For Type 627 and 627R regulators (figure 5), use steps 5 through 8 to remove and replace the stem assembly.
5. Remove the boost body (key 6), stabilizer (key 7), and stem guide (key 8) from the diaphragm casing (key 5). Unhook and remove the stem (key 10) from the diaphragm casing (key 5).
6. Remove and inspect the diaphragm casing O-ring (key 4, figure 7 or 8) and replace it if necessary.

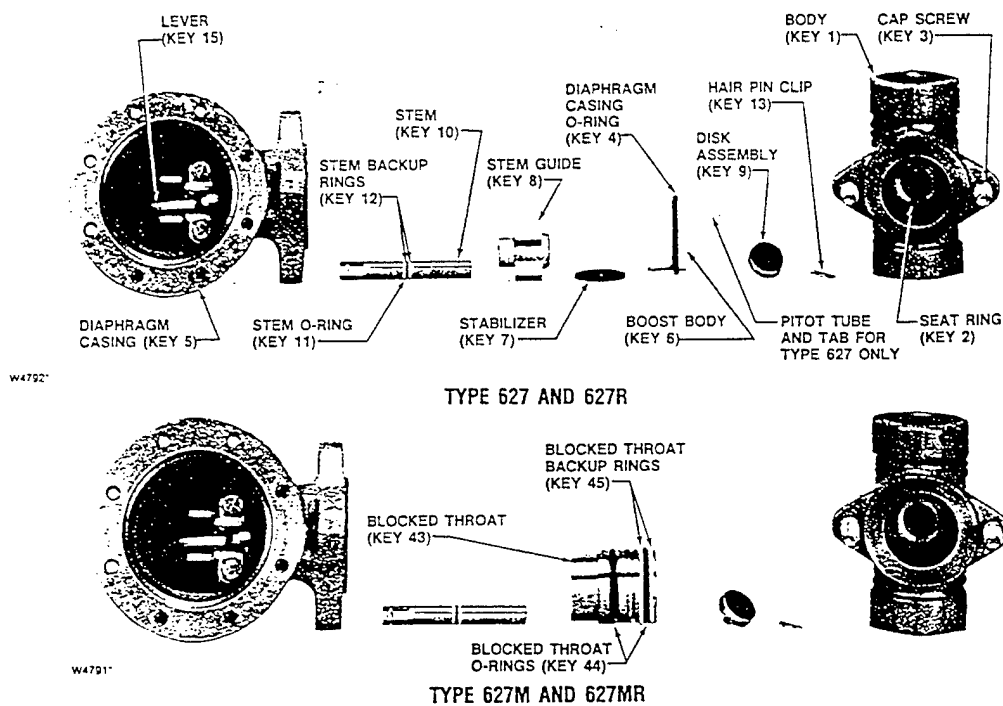

Figure 5. Stem Assemblies

7. Apply lubricant (key 42) to a replacement diaphragm casing O-ring (key 4, figure 7 or 8) and install it onto the boost body (key 6). Skip to step 14.

8. For the Type 627 regulator, be sure to insert the pitot tube (tab) into the outlet side of the body (see figure 7). Skip to step 14.

**Perform steps 9 through 19 for Type 627M and 627MR Regulators only:**

9. For Type 627M and 627MR regulators (figure 5), use steps 10 through 14 to remove and replace the stem assembly.

10. To remove the blocked throat (key 43), insert a screw driver blade into the groove provided in the throat and pry it out of the diaphragm casing (key 5). Inspect and replace parts as necessary.

11. Inspect and, if necessary, replace the blocked throat O-rings (key 44, figures 9 and 10) and backup rings (key 45, figures 9 and 10).

12. Apply lubricant (key 42) to replacement blocked throat O-rings (key 44) and backup rings (key 45).

13. Apply lubricant (key 42) to the replacement stem O-ring (key 11) and stem backup rings (key 12) and install them on the stem (key 10).

14. For assembly, insert the stem (key 10) into the diaphragm casing (key 5) and hook it on the lever (key 15).

15. Insert parts into the diaphragm casing (key 5) that were removed in steps 5 and 6 or step 10 (see figure 5).

16. Install the the disk assembly (key 9), line up the hole in the disk assembly and stem (key 10) and insert the hair pin clip (key 13).

17. Position the diaphragm casing plus attached parts in relation to the body (key 1) so that they are correct for the application.

18. Secure the diaphragm casing to the body with the cap screws (key 3, figure 5). For an aluminum diaphragm casing (key 5), torque the cap screws (key 3) to 16 foot-pounds (22 N·m). For ductile iron or steel diaphragm casings, torque the cap screws (key 3) to 25 foot-pounds (34 N·m).

19. It may be necessary to reposition the diaphragm spring case to prevent rain, ice, and foreign debris from entering the spring case. Refer to the diaphragm and spring case area maintenance procedures, steps 1, 2, and 21 through 25.

### Diaphragm and Spring Case Area Maintenance Procedures

These procedures are for gaining access to the control spring, diaphragm assembly, and lever assembly. All spring pressure must be released from the diaphragm casing before these steps can be performed.

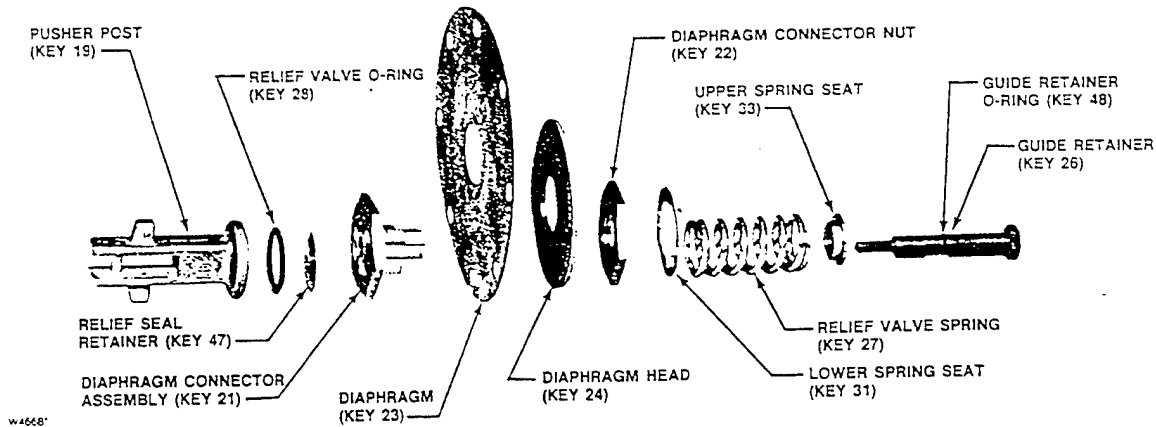

Figure 6. Diaphragm Assembly with Relief Valve Parts

1. Remove the adjusting screw cap (key 36), loosen the lock nut, and turn the adjusting screw (key 35) counterclockwise until all compression is removed from the control spring (key 32).

2. Remove the spring case cap screws (key 37), the nameplates, and lift off the spring case (key 29). If changing the control spring (key 32) or repositioning the spring case (key 29) is the only maintenance required, install the replacement control spring or rotate the spring case so it is correct for the application. Skip to step 21. For diaphragm area maintenance, continue with step 3.

3. Remove the diaphragm assembly by tilting it so that the pusher post (key 19) slips off the lever (key 15).

4. If it is necessary to replace the lever assembly, remove the lever cap screws (key 18).

5. Install the replacement lever (key 15) into the lever retainer (key 16) by inserting the lever pin (key 17). Secure the lever assembly into the diaphragm casing with the cap screws (key 18) and torque the cap screws to 7 foot-pounds (9 N•m).

If it is necessary to perform maintenance on the diaphragm assembly, continue with steps 6 through 11 and step 20 for Type 627 and 627M regulators, or steps 12 through 19 for Type 627R and 627MR regulators.

**Perform steps 6 through 11 for Type 627 and 627M Regulators only:**

6. For Type 627 and 627M regulators (figures 7 and 9), use steps 7 through 11 to disassemble and reassemble the diaphragm assembly.

7. Remove the cap screw (key 46), lower spring seat (key 31), and diaphragm plate (key 24), then separate the diaphragm (key 23) from the pusher post (key 19).

8. Install the diaphragm (key 23), diaphragm plate (key 24), and lower spring seat (key 31) on the pusher post (key 19), insert and finger tighten the diaphragm plate cap screw (key 46).

9. Hook the pusher post on the lever (key 15), then turn the diaphragm (key 23) to match the holes in the diaphragm with the holes in the spring casing.

10. Unhook the pusher post from the lever and torque the diaphragm head cap screw (key 46) to 7 foot-pounds (9 N•m).

11. Hook the pusher post on the lever (key 15) and check the hole alignment. If necessary, loosen the cap screw (key 46) and reposition the diaphragm (key 23) on the pusher post (key 19). Retorque the screw (see step 10). Skip to step 20.

**Perform steps 12 through 19 for Type 627R and 627MR Regulators only:**

12. For Type 627R and 627MR regulators (figure 6), use steps 13 through 19 to disassemble and reassemble the diaphragm assembly:

13. Remove the guide retainer (key 26) and separate the diaphragm parts. Refer to figure 6 for the sequence of parts.

14. To remove the diaphragm (key 23), remove the diaphragm connector nut (key 22) and lift off the diaphragm head (key 24) and diaphragm (key 23) from the connector assembly (key 21). Do not attempt to disassemble the connector assembly (key 21).

15. Position the replacement diaphragm (key 23) on the connector assembly (key 21), install the diaphragm head (key 24) and connector nut (key 22), then torque to 17 foot-pounds (32 N•m).

16. If necessary, replace the guide retainer O-ring (key 48) and, set the guide retainer (key 26) aside, ready for assembly.

17. On the pusher post (key 19) install the relief seal O-ring (key 28) and lubricate (key 42). Also, install the relief seal retainer (key 47), diaphragm connector assembly (key 21, with attached parts) relief spring (key 27), upper relief spring seat (key 33), and guide retainer (key 26). Torque the guide retainer (key 26) to 3 foot-pounds (4 N•m).

18. Hook the pusher post (with attached parts) on the lever (key 15) to check the alignment of the holes in the diaphragm with the holes in the spring casing. If the holes do not line up, unhook the pusher post from the lever, hold the pusher post, and rotate the diaphragm to the correct position.

19. Install the lower spring seat (key 31) over the relief spring so it rests flat on the connector nut (key 22).

20. Insert the diaphragm assembly into the diaphragm casing (key 5) and hook the pusher post on the lever (key 15).

21. Install the control spring (key 32) and upper spring seat (key 33), and apply lubricant (key 38) to the upper spring seat (key 33).

22. Install the spring case (key 29) so that the screened vent assembly (key 30) is in the correct posi-

tion for the application. Place the nameplates (key 39) over the screw holes, insert the spring case cap screws (key 37), and finger tighten.

23. Screw in the adjustment screw to put slack into the diaphragm (key 23).

24. Using a crisscross pattern, finish tightening the spring case cap screws (key 37) to 7 foot-pounds (9 N•m) of torque.

25. If necessary, refer to the installation and/or the startup and adjustment procedures.

26. Install the adjusting screw cap (key 34) after regulator adjustment.

## Parts Ordering

When corresponding with your Fisher sales office or sales representative about this regulator, always reference the type number which is found on the nameplate (key 39, figures 7 through 10).

When ordering replacement parts, reference the key number of each needed part as found in the following parts list.

## Parts List

Key	Description	Part Number	Key	Description	Part Number
			1	Body (Continued)	
				Steel	
				2000 psig (138 bar)	
				max inlet pressure	
				3/4-inch NPT size	30B3050 X012
				1-inch NPT size	30B3051 X012
				2-inch NPT size	30B7452 X012
				Steel, raised face flanged,	
				ANSI Class 600	
				1480 psig (102 bar)	
				max inlet pressure	
				1-inch size	40B6754 X012
				2-inch size	40B6756 X012
			2*	Seat ring	
				Aluminum	
				3/32-inch (2.4 mm) port	
				diameter	0R044114 012
				1/8-inch (3.2 mm) port	
				diameter	1A9367 09012
				3/16-inch (4.8 mm) port	
				diameter	009912 09012
				1/4-inch (6.4 mm) port	
				diameter	0B0420 09012
				3/8-inch (9.5 mm) port	
				diameter	0B0422 09012
				1/2-inch (12.7 mm) port	
				diameter	1A9288 09012
				Stainless steel	
				3/32-inch (2.4 mm) port	
				diameter	0R044135 032
			2*	Seat Ring (Continued)	
				1/8-inch (3.2 mm) port	
				diameter	1A9367 35032
				3/16-inch (4.8 mm) port	
				diameter	009912 35032
				1/4-inch (6.4 mm) port	
				diameter	0B0420 35032
				3/8-inch (9.5 mm) port	
				diameter	0B0422 35032
				1/2-inch (12.7 mm) port	
				diameter	1A9288 35032
			3	Cap Screw (not shown), (2 req'd)	
				Type 627 and 627R w/aluminum	
				diaphragm case,	
				pl steel	18A1087 X012
				All Types w/ductile iron	
				or steel diaphragm	
				case, pl steel	1C4038 24052
			4*	Diaphragm Case O-Ring (Type 627 or	
				627R only), nitrile	17A2325 X022
			5	Diaphragm Case	
				For Type 627 or 627R	
				Aluminum	40B3084 X012
				Ductile iron	30B3053 X012
				Steel	30B3104 X012
				For Type 627M or 627MR	
				Ductile iron	39A5987 X012
				Steel	30B8734 X012
1	Body				
	Ductile iron				
	1000 psig (69 bar)				
	max inlet pressure				
	3/4-inch NPT size	30B3046 X012			
	1-inch NPT size	30B3048 X012			
	2-inch NPT size	30B3096 X012			

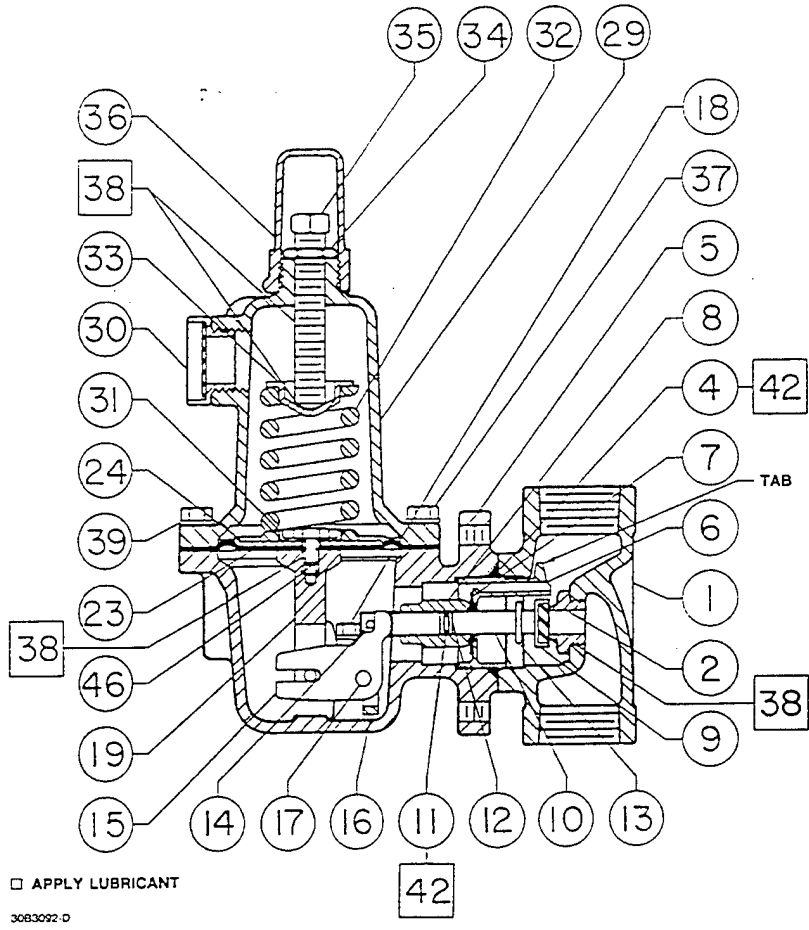

Figure 7. Type 627 Regulator Components

Key	Description	Part Number	Key	Description	Part Number	Key	Description	Part Number
6	Boost Body (not for Type 627M or 627MR), Delrin <sup>(1)</sup> For Type 627 30B3056 X012 For Type 627R 30B3057 X012		13	Hair Pin Clip, stainless steel 10B3058 X012		23*	Diaphragm, nitrile For Type 627 or 627M w/aluminum or ductile iron diaphragm case 10B3069 X012 For Type 627 or 627M w/steel diaphragm case 10B8735 X012 For Type 627R or 627MR w/aluminum or ductile iron diaphragm case 10B3068 X012 For Type 627R or 627MR w/steel diaphragm case 10B8736 X012	
7	Stabilizer (for Type 627 or 627R only), nitrile 10B3060 X012		14	Drive Pin, zn pl steel 1A9532 28982		24	Diaphragm Head, pl steel For Type 627 or 627M 10B3098 X012 For Type 627R or 627MR 10B3098 X022	
8	Stem Guide (for Type 627 or 627R only), powdered metal 20B3061 X012		15	Lever, zn pl steel 20B3063 X012		25	Relief Spring Seat (for Type 627R or 627MR only), steel 10B7446 X012	
9*	Disk Assembly (for all port diameters) Aluminum holder and nitrile disk 1C4248 X0212 Stainless steel holder and nitrile disk 1C4248 000A2 Aluminum holder and polyurethane disk 1C4248 X0242 Stainless steel holder and polyurethane disk 1C4248 X0232		16	Lever Retainer, zn pl steel 30B3097 X012		26	Guide Retainer (for Type 627R or 627MR only), stainless steel 10B7450 X012	
10	Stem, stainless steel 10B3059 X012		17	Lever Pin, stainless steel 10B3083 X012		27	Relief Spring (for Type 627R or 627MR only), pl steel 10B6757 X012	
11*	Stem O-Ring, nitrile 1D6875 06992		18	Lever Cap Screw, pl steel (2 req'd) 10B7454 X012				
12	Stem Backup Ring, TFE (2 req'd) 1K7868 06992		19	Pusher Post, aluminum For Type 627 or 627M 10B3098 X012 For Type 627R or 627MR 10B3098 X022				
			21	Diaphragm Connector (for Type 627R or 627MR only), stainless steel 10B6758 X012				
			22	Diaphragm Connector Nut (for Type 627R or 627MR only), stainless steel 10B7449 X012				

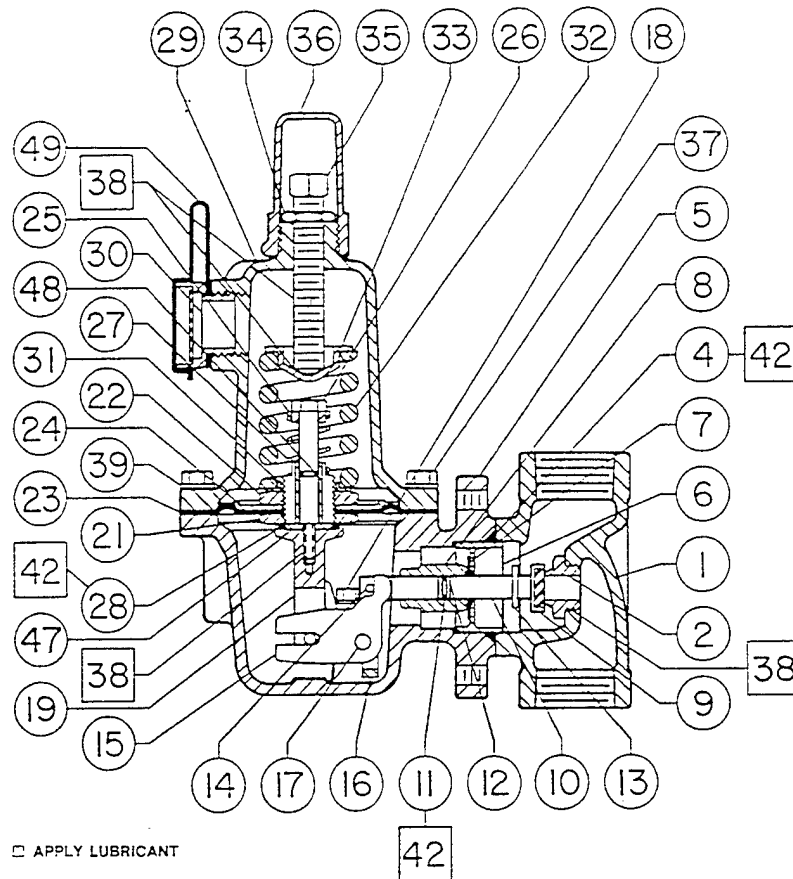

Figure 8. Type 627R Regulator Components

Key	Description	Part Number	Key	Description	Part Number	Key	Description	Part Number
28*	Relief Seal O-Ring (for Type 627R or 627MR only), nitrile	1J1085 06992	33	Upper Spring Seat, pl steel	1D6671 25072	43	Blocked Throat (for Type 627M or 627MR only), stainless steel	10B3085 X012
29	Spring Case For Type 627 or 627R Aluminum	40B3086 X012	34	Locknut, zn pl steel	1D6677 28982	44	Blocked Throat O-Ring (for Type 627M or 627MR only), nitrile (2 req'd)	1E2643 06992
	Ductile iron	30B3055 X012	35	Adjusting Screw, pl steel For Type 627 or 627M	10B3081 X012	45	Blocked Throat Backup Ring (for Type 627M or 627MR only), TFE (2 req'd)	10B3106 X012
	Steel	30B3102 X012	36	Adjusting Screw Cap, aluminum	20B3082 X012	46	Diaphragm Head Cap Screw (for Type 627 or 627M only), pl steel	1K9207 24052
	For Type 627M or 627MR Ductile iron	30B3055 X012	37	Spring Case Cap Screw, pl steel (8 req'd) For aluminum or ductile iron diaphragm case	1A3917 24052	47	Relief Seal Retainer (for Type 627R or 627MR only), stainless steel	10B7445 X012
	Steel	30B3102 X012		For steel diaphragm case	10B8737 X012	48*	Guide Retainer O-Ring (for Type 627R or 627MR only), nitrile	1D6825 06992
30	Screened Vent Assembly, plastic	10B3093 X012	38*	Lubriplate Mag-1 <sup>(2)</sup> , Lubricant, 0.9 pound can. Not furnished with regulator	1M1100 X0012	49	Relief Indicator (for Type 627R or 627MR only), rubber (not shown)	30B3100 X012
31	Lower Spring Seat, zn pl steel For Type 627 or 627M	1D6666 25072	39	Nameplate, aluminum, (see figure 2) Number 1	10B3679 X032			
	For Type 627R or 627MR	20B3073 X012		Number 2	10B3679 X022			
32	Control Spring, pl steel 10 to 20 psig range (0.7 to 1.4 bar), yellow color code	10B3076 X012	42*	Dow Corning 33 <sup>(3)</sup> , Lubricant, Not furnished with regulator	T13078 T0012			
	15 to 40 psig range (1.0 to 2.8 bar), green color code	10B3077 X012						
	35 to 80 psig range (2.4 to 5.5 bar), blue color code	10B3078 X012						
	70 to 150 psig range (4.8 to 10.3 bar), red color code	10B3079 X012						

\*Recommended spare part.  
2. Trademark of Fiske Brothers Refining Co.  
3. Trademark of Tretolite Division of Petrolite Corp.

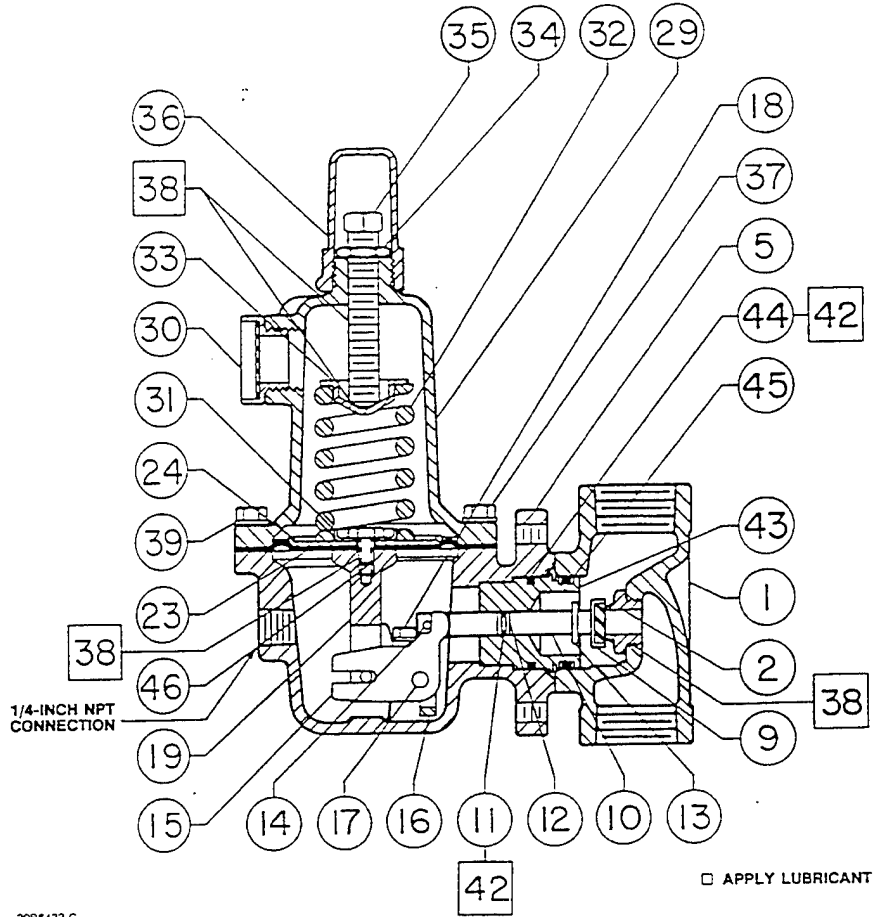

Figure 9. Type 627M Regulator Components

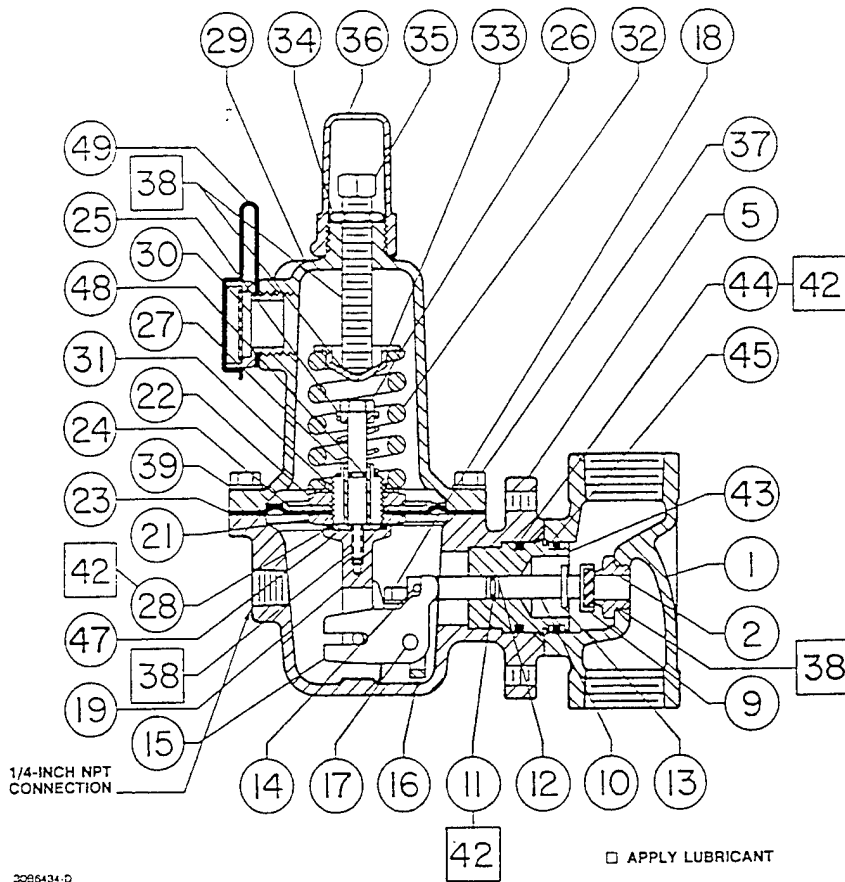

Figure 10. Type 627MR Regulator Components

While this information is presented in good faith and believed to be accurate, Fisher Controls does not guarantee satisfactory results from reliance upon such information. *Nothing contained herein is to be construed as a warranty or guarantee, express or implied, regarding the performance, merchantability, fitness*

*or any other matter with respect to the products, nor as a recommendation to use any product or process in conflict with any patent. Fisher Controls reserves the right, without notice, to alter or improve the designs or specifications of the products described herein.*



**Fisher Controls**

For information, contact Fisher Controls:  
Marshalltown, Iowa 50158 USA  
Rochester, Kent, England ME2 2EZ

Sao Paulo 05424 Brazil  
Singapore 1130

# FUNCTIONING, TEST AND INSPECTION OF RELIEF VALVES

## REPAIR AND TESTING

Safety relief valves for LP-Gas containers are tested and listed by Underwriters' Laboratories, Inc. in accordance with NFPA Pamphlet No. 58, Standards of the National Board of Fire Underwriters for the Storage and Handling of Liquefied Petroleum Gases.

Construction and performance of safety relief valves are constantly checked at the factory by UL inspectors. Therefore, testing of safety relief valves in the field is not necessary. Any changes in the setting of safety relief valves, or any repairs in the field, will void the UL Listing and may very well create a serious hazard.

While the functioning of a safety relief valve appears to be a relatively simple thing, the assembly and test procedure used by the manufacturer is quite involved. Highly specialized test fixtures are necessary to attain the proper setting and the personnel setting the safety relief valves must have highly specialized training and long experience in the techniques involved.

Specialized assembly and test fixtures are available only at the plant of the safety relief valve manufacturer, and it is recommended that should a safety relief valve be suspect as to its performance, it be returned to the manufacturer for repair or replacement.

## OPERATION OF SAFETY RELIEF VALVES

A safety relief valve is set and sealed at the factory by the manufacturer to function at a specific "start-to-discharge" pressure in accordance with the regulations. This set pressure as marked on the safety relief valve depends on the design requirement of the containers which are to be protected by the safety relief valve. If the container pressure reaches the start-to-discharge pressure, the safety relief valve will open a very slight amount. If the pressure in the container continues to rise despite the discharge through the safety relief valve, the valve will suddenly "pop" wide open. The action is accompanied by a sharp noise from which the term "pop-action" of the valve is derived.

Whether the valve opens by merely a slight amount or pops wide open, if the pressure in the container then diminishes, the valve will start to close and after the pressure has decreased sufficiently, the safety relief valve spring will force the seat disc against the seat tightly enough to prevent any further escape of gas. The pressure at which the valve closes tightly is referred to as the "re-seal" or "blow-down" pressure. This pressure may or may not be the same as the start-to-discharge pressure. Generally speaking, the re-seal pressure

will be lower than the start-to-discharge pressure. The re-seal pressure can, and in most cases is, adversely affected by the presence of dirt, rust or scale lodging upon the seat or disc. Such foreign particles interfere with the proper mating of the seat and disc and the pressure in the container will usually have to decrease to a certain extent before the safety relief valve spring acquires sufficient force to embed the foreign particles in the resilient seat disc material and finally effect a leak-tight seal. The degree by which the presence of dirt decreases the re-seal pressure is, of course, dependent on the size of the interfering particles.

Once these particles have been trapped between the disc and the seat it is evident that the start-to-discharge pressure is also affected. If the pressure rises in the container, the safety relief valve will start to discharge at some pressure lower than its original start-to-discharge pressure. Again, the pressure at which the valve will start to discharge is dependant on the size of the foreign particles.

In the case of a safety relief valve that has opened very slightly due to a pressure beyond its start-to-discharge setting, the chances of foreign material lodging on the seat are somewhat negligible although the possibility is always present. It is, therefore, usually unnecessary to return such valves to the factory for resetting unless the valve continues to leak at pressures appreciably below its start-to-discharge setting.

Safety relief valves which have been caused to "pop" wide open for one reason or another as a result of having been subjected to excessive container pressure should be returned to the factory of the manufacturer for the servicing if there is any doubt as to the proper operation of the valves. Mal-functioning of a safety relief valve could be caused by improper installation, accumulation of foreign particles on the disc or seat of the valve, exposure to excessive heat, etc.

The pressure at which a safety relief valve will start to discharge should never be judged by the reading of the pressure gauge normally furnished on the LP-Gas container. The reasons for this are two-fold:

- a) If the safety relief valve is called upon to open, the resulting discharge produces an increased vaporization of the LP-Gas in the container with the result that the liquid cools to a certain extent and the vapor pressure drops. A reading taken at this time would obviously not indicate what the pressure was when the safety relief valve opened.
- b) The pressure gauges usually used on LP-Gas containers provide somewhat approximate readings and are not intended to provide an indication of pressure sufficiently accurate to judge the setting of the relief valve.

# UPRIGHT "POP-ACTION"

## SAFETY RELIEF VALVES

### REGO 3131, 3132, W3132, 3133, 3135 & 3149 SERIES

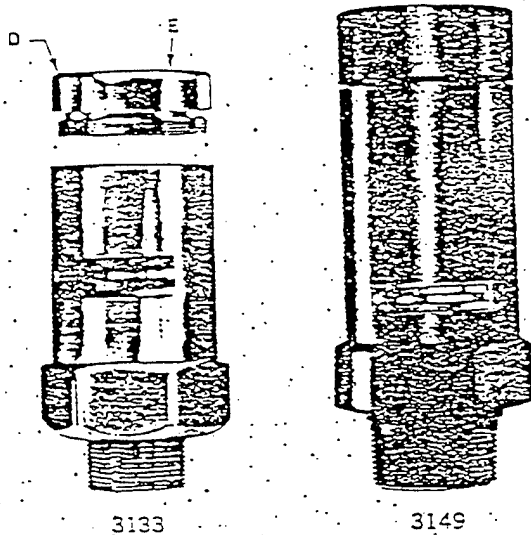

3133

3149

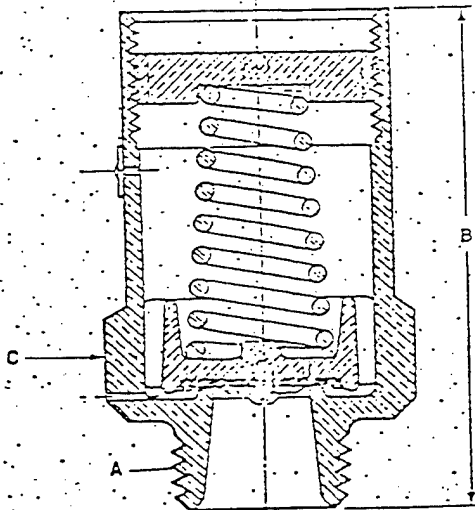

### APPLICATION

These safety relief valves are designed to provide primary relief for ASME aboveground and underground containers, bulk plant installations, skid tanks, etc. The 3131 series safety relief valves may also be used as primary or secondary safety relief devices on ICC cylinders, or as hydrostatic relief valves.

### FEATURES

"Pop-Action" design assures minimum product loss. After discharging, the safety relief valve automatically reseats firmly. The resilient seat disc provides a "bubble-tight" seal. The Set Pressure and Capacity is permanently marked on each valve for quick, easy reference.

Optional Features (Must be specified on order):

Adapter—Permits addition of discharge piping.

Rain Cap—Prevents entrance of foreign material.

Weep Hole Deflector—Furnished as standard on 3149, A3149 and A3149L valves. Provides protection against flame impinging on adjacent containers.

### MATERIALS

	3131, W3132 3132, 3133, 3135	3149	A3149, A3149L
Body	Brass	C.R. steel body with stainless steel liner	Ductile iron wrench section.
Spring Guide	Brass	Brass	303 Stainless Steel
Spring	Corrosion Resistant Steel		
Seat Disc	Synthetic Rubber		

### SPECIFICATIONS

Key	Description	Safety Relief Valve					
		3131	W3132	3132	3135	3133	3149 A3149 A3149L
A	Inlet connection (NPT Male)	3/4"	1"	1-1/4"	1-1/4"	1-1/2"	2-1/2"
B	Overall height of valve	3-7/16"	5-7/32"	5-7/32"	5-21/32"	5-15/16"	10-1/2"
	Height with adapter	—	6-1/32"	6-1/32"	6-11/16"	6-9/16"	*
C	Wrenching section (Hex)	1-3/4"	2-3/8"	2-3/8"	2-11/16"	3-1/8"	4-1/8"
D	Adapter part number	3131-10†	3132-10	3132-10†	3135-10	3133-10	**
E	Adapter outlet conn. (NPT, Female)	1"	1-1/4"	1-1/4"	2"	2"	*
	Raincap part number	3131-40	3132-40	3132-40	3135-40	3133-40	—
	Weep Hole Deflector part number	—	3133-11	3133-11	3133-11	3133-11	**

### HOW TO ORDER

Specify complete safety relief valve number, including proper suffix letter designation to meet relief requirements. Part number of desired accessories shown in "Specifications" charts should also be specified on order.

\*Have integral adapter with 3/4" —8N female outlet thread. Will accept pipe threaded 3" NPT.

\*\*Furnished as standard.

† Cannot be used when B or G settings are specified. When adapter is required, specify T3131 or T3132 series valves. In cases requiring short piping through the hood, 3131-45 or 3132-45 Rain Caps and Extension Tube assemblies are recommended (see page 18).

**KUNKLE**<sup>®</sup>

VALVE CO.

MODEL  
900  
SERIES

BRONZE, STEEL  
& STAINLESS  
STEEL SAFETY  
RELIEF VALVES

FOR AIR, GAS,  
STEAM, LIQUID  
& VACUUM SERVICE



**LONERGAN**<sup>®</sup>  
Valve Division

**MODEL  
A  
SERIES**

**GREAVES CO., INC.**

MANUFACTURERS' REPRESENTATIVE AND DISTRIBUTORS  
P.O. BOX 99267 \* 4411 23rd AVE. N., SEATTLE, WA. 98199  
206-284-0660 \* FAX 206-285-6893

# BRONZE, STEEL & STAINLESS STEEL SAFETY RELIEF VALVES

FOR AIR, LIQUID  
STEAM SERVICE

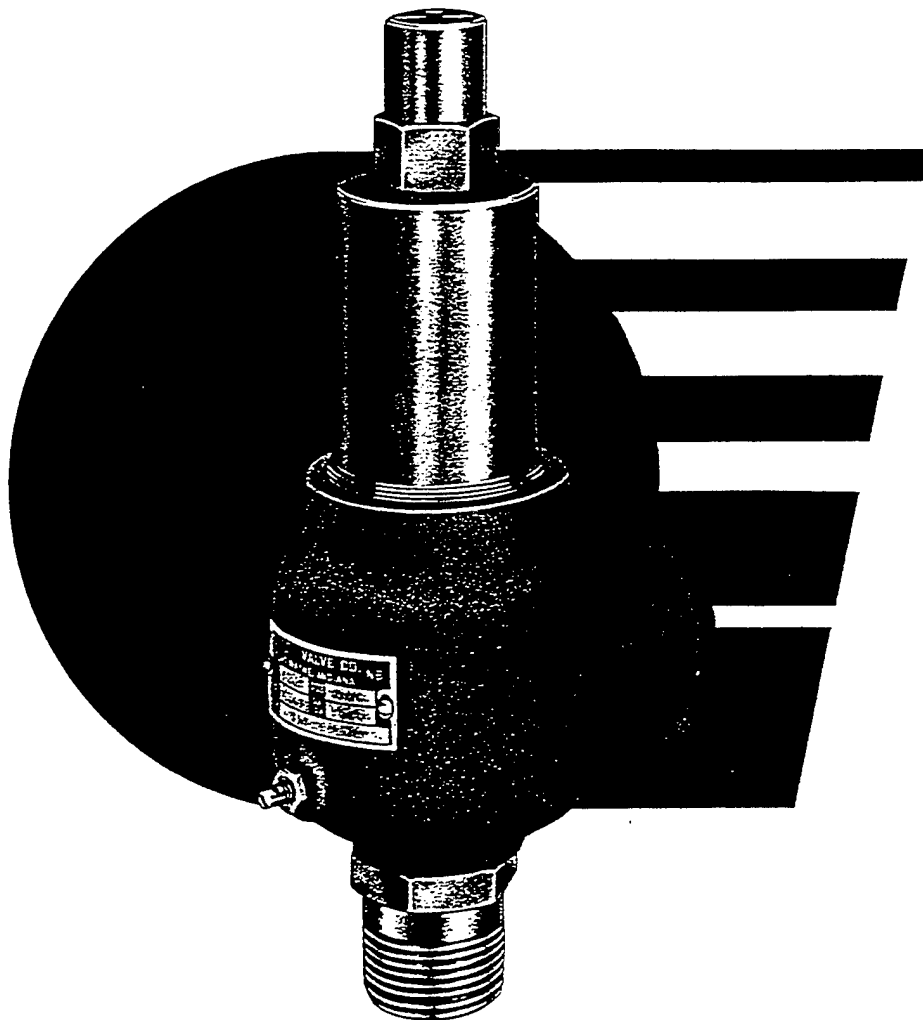

## MODEL A SERIES

### PRESSURE LIMITS

900 PSIG — 800°F Models ACA, AAA, ACS ▷ (Note: Spring Option Temperature Limits)  
 900 PSIG — 422°F Model ABB with Stainless Steel Trim ▷  
 300 PSIG — 406°F Model ABB with Brass/Bronze Trim — Air/Gas Service ▷  
 250 PSIG — 406°F Model ABB with Brass/Bronze Trim — Steam Service ▷  
 50 PSIG Max. Back Pressure Limit Screwed Cap and Packed Lift Lever Models  
 Soft Seat Disc Design Temperature Limit 400°F

### APPLICATIONS

- Air/Gas Compressors — Intercoolers — Aftercoolers.
- Liquid Filled Pressure Vessels/Systems — ASME Section VIII (UV).
- High Temperature/Pressure Hotwater Boilers — ASME Section I (V) HTHW.
- Pressure Vessels — Containing Gas, Air, Liquid or Steam. Including Tanks and Receivers.
- Process and Industrial applications requiring steel/stainless steel construction, including acid, caustic, ammonia or other corrosive.
- Optional materials for low-temperature — cryogenic applications.
- Oil/Gas Separators.
- Overpressure relief and protection of pumps, tanks, lines and hydraulic systems.
- By-pass relief or pressure regulation.
- All 316 stainless steel Models AAA, AAO suitable for sanitary/edible applications.

### FEATURES

SERIES ABB	Bronze Body	Bronze Trim	Carbon Steel Spring
SERIES ABB	Bronze Body	Stainless Steel Trim	Carbon Steel Spring
SERIES ACA	Carbon Steel Body	Stainless Steel Trim	Carbon Steel Spring
SERIES AAA	Stainless Steel Body	Stainless Steel Trim	Stainless Steel Spring
SERIES ACS	Carbon Steel Body	Stainless Steel Trim	Stainless Steel Spring
	High Temperature/Pressure		Packed Lift Lever
	Hot Water Boilers (ASME Section I - "V" HTHW).		

SERIES ABO Same as ABB Except Soft Seat Seal  
 SERIES ACO Same as ACA or ACS Except Soft Seat Seal  
 SERIES AAO Same as AAA Except Soft Seat Seal  
 For proper soft seat material selection, consult D & L Series Catalog.

OPTIONS Plain Lift Lever.  
 Packed lift lever (Pressure tight).  
 Stainless Steel Trim (Model ABB).  
 Stainless Steel Spring — To 600 degrees F.  
 Hi-temperature (Alloy steel) spring — To 800 degrees F.  
 Cryogenic-low temperature materials/preparation.  
 Vibration dampening spring on plain lever.

NOTE: ASME valves for air or steam service must have lift lever.  
 For Steam Boilers, Economizers and Generators — ASME Sec I (V) Use BCA Series.

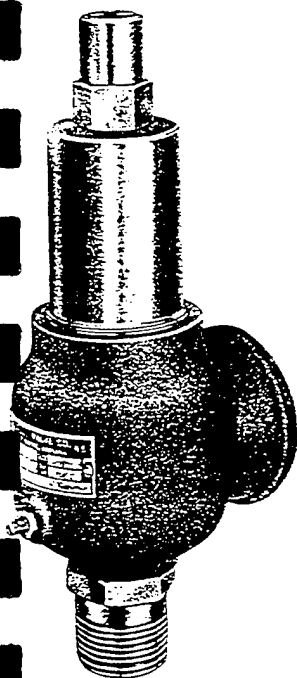

(SCREWED)

MODEL  
ACA  
ABB  
AAA

Order # 2342  
Part # 3494  
1000000000  
1000000000  
1000000000  
1000000000

## MODEL NUMBER / ORDER GUIDE

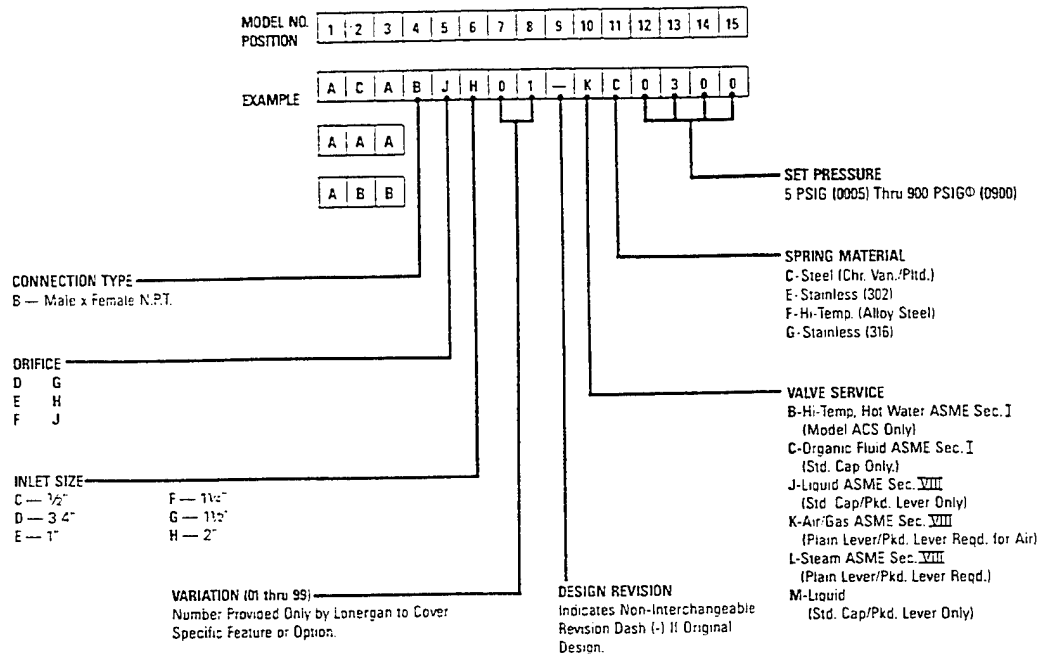

## MODEL A SERIES DIMENSIONS / SPECIFICATIONS

### CONNECTIONS MALE INLET — FEMALE OUTLET

IN-LET	VALVE SIZE ORI-FICE	OUT-LET	ORIFICE AREA	SERIES	MODEL ABB W BRONZE TRIM	MODELS ACA, AAA, ACS MODELS ABB W SS TRIM	A STD. CAP	A PLAIN LEVER	VALVE DIMENSIONS A PACKED LEVER	B	C	APPROX. WT LBS.
					MAX. SET PRESSURE PSIG	MAX. SET PRESSURE PSIG						
1/2 x D	x 3/4	3/4	0.121	ABBBDC	300	900	7 1/4	8 3/8	9	1 3/8	2 3/8	3
1/2 x D	x 1	1	0.121	A**BDC	300	900	7 1/4	8 3/8	9	1 3/8	2 3/8	3
3/4 x D	x 3/4	3/4	0.121	ABBBDD	—	900	7 1/4	8 3/8	9	1 3/8	2 3/8	3
1 x D	x 1	1	0.121	ABBBDE	—	900	7 1/4	8 3/8	9 3/8	1 3/8	2 3/8	3
3/4 x E	x 1 1/4	1 1/4	0.216	A**BED	300	900	7 5/8	8 3/4	9 3/8	2	2 3/8	4
1 1/4 x E	x 1 1/4	1 1/4	0.216	ABBBEF	—	900	8	9 1/2	9 3/4	2	3	4
1 x F	x 1 1/2	1 1/2	0.337	A**BFE	300	600	8 3/4	9 3/8	10 1/2	2 3/8	2 3/8	6
1 1/2 x F	x 1 1/2	1 1/2	0.337	ABBBFG	—	600	8 3/8	10	10 3/8	2 3/8	3	6
1 1/4 x G	x 2	2	0.553	A**BGF	300	600	10 1/8	11 1/4	11 3/4	2 3/8	3 1/4	8
2 x G	x 2	2	0.553	ABBBGH	—	600	10 1/8	11 1/4	11 3/4	2 3/8	3 1/4	8
1 1/2 x H	x 2 1/2	2 1/2	0.864	A**BHG	300	500	11 1/8	13	12 1/2	2 3/4	3 1/2	11
2 x J	x 3	3	1.415	A**BJH	300	500	12 1/2	14 1/2	15 1/8	3 1/4	4	15

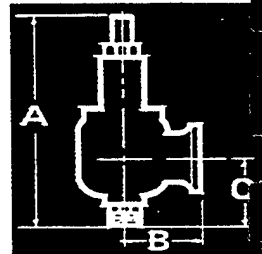

Ⓢ Available with Stainless Steel Trim Only.  
Ⓞ Available Model ABB Only.  
\*\* Replace asterisk with desired model letters. Data applicable to all models.

## PARTS AND MATERIALS

NO.	PART NAME	ABB MATERIAL	ACA/ACS MATERIAL
1	Base	Brass/Bronze	Stainless Steel
2	Seal (Body)	Teflon	Teflon
3	Body	Bronze	Steel
4	Warn Ring	Stainless Steel	Stainless Steel
5	Seal (Set Screw)	Teflon	Teflon
6	Locknut (Set Screw)	Brass	Stainless Steel
7	Set Screw (Warn Ring)	Brass	Stainless Steel
8	Nameplate	Aluminum	Stainless Steel
9	Drivescrew	Steel Pltd.	Stainless Steel
11	Cap	Brass	Steel
12	Pin	Stainless Steel	Stainless Steel
13	Seal (Bonnet)	Teflon	Teflon
14	Guide	Brass/Bronze	Stainless Steel
15	Bonnet	Brass/Bronze	Steel
16	Spring	Steel Pltd.	Steel Pltd.
17	Seal	Lead & Wire	Lead & Wire
18	Step-Spring	Brass	Steel Pltd.
19	Pipe Plug (Drain)	Brass	Steel — St/Steel
20	Stem	Brass	Stainless Steel
23	Screw-Compression	Brass	Stainless Steel
24	Nut-Lift	Stainless Steel	Stainless Steel
25	Screw-Set	Steel Pltd.	Steel Pltd.
26	Lever	Steel Pltd.	Steel Pltd.
27	Cap	Copper Alloy	Copper Alloy
28	Pin-Lever	Steel	Steel
29	Lever	Steel Pltd.	Steel Pltd.
30	Dog-Lift	Stainless Steel	Stainless Steel
31	Pin-Cotter	Steel Pltd.	Steel Pltd.
32	Seal (Dog)	Buna-N	Buna-N
33	Retainer (Dog)	Brass	Stainless Steel
34	Seal (Retainer)	Buna-N	Buna-N
39	Disc Holder	Brass/Bronze	Stainless Steel
40	Retainer (Disc)	Stainless Steel	Stainless Steel
41	Disc	Stainless Steel	Stainless Steel
47	Lift Disc	Stainless Steel	Stainless Steel
48	Locknut (Com. Scr.)	Brass	Stainless Steel
49	Seal (Cap)	Buna-N	Teflon

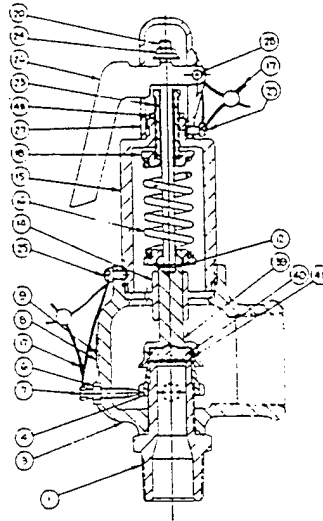

(PLAIN LEVER)  
**MODELS  
ACA, AAA,  
ABB**

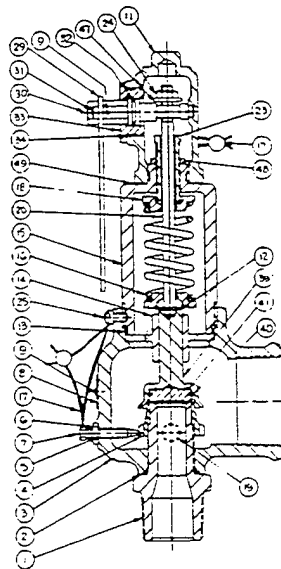

(PACKED LEVER)  
**MODELS  
ACA, AAA,  
ABB, ACS**



## STEAM / AIR / LIQUID CAPACITIES A SERIES

To correct capacities for superheat or temperature other than 60°F, see Technical Catalog

Orifice Area	D .121 Sq. In.				E .216 Sq. In.				F .337 Sq. In.				G .553 Sq. In.				H .864 Sq. In.				J 1.415 Sq. In.						
	Lbs. Hr. Mod. ACS Hi-Temp		Lbs. Hr. Mod. ACS Hi-Temp		Lbs. Hr. Mod. ACS Hi-Temp		Lbs. Hr. Mod. ACS Hi-Temp		Lbs. Hr. Mod. ACS Hi-Temp		Lbs. Hr. Mod. ACS Hi-Temp		Lbs. Hr. Mod. ACS Hi-Temp		Lbs. Hr. Mod. ACS Hi-Temp		Lbs. Hr. Mod. ACS Hi-Temp		Lbs. Hr. Mod. ACS Hi-Temp		Lbs. Hr. Mod. ACS Hi-Temp						
	Hot Water	Lbs. Hr. Steam	SCFM Air	GPM Liquid	Hot Water	Lbs. Hr. Steam	SCFM Air	GPM Liquid	Hot Water	Lbs. Hr. Steam	SCFM Air	GPM Liquid	Hot Water	Lbs. Hr. Steam	SCFM Air	GPM Liquid	Hot Water	Lbs. Hr. Steam	SCFM Air	GPM Liquid	Hot Water	Lbs. Hr. Steam	SCFM Air	GPM Liquid			
5	88	31	9	157	56	16	245	87	26	403	143	42	629	224	66	1031	367	106									
10	151	54	12	270	96	21	422	150	33	692	247	54	1062	385	84	1771	631	136									
20	200	73	16	358	131	28	558	204	44	916	336	72	1432	524	112	2345	859	183									
30	255	93	19	455	166	33	711	259	52	1165	425	86	1822	663	134	2983	1066	219									
40	310	114	22	553	204	39	863	318	60	1416	522	99	2212	816	155	3622	1337	253									
50	364	136	24	650	242	43	1015	378	67	1655	620	111	2602	969	173	4261	1587	283									
60	419	157	27	748	281	47	1167	438	74	1915	718	121	2992	1122	189	4900	1838	310									
70	474	179	29	846	319	51	1321	497	80	2167	816	131	3386	1275	205	5545	2088	335									
80	530	200	31	947	357	55	1477	557	85	2424	914	140	3788	1428	219	6203	2339	358									
90	587	221	32	1047	395	58	1634	617	90	2681	1012	148	4189	1581	232	6861	2589	380									
100	643	243	34	1148	434	61	1791	676	95	2939	1110	156	4591	1734	244	7519	2840	400									
125	784	296	38	1399	529	68	2183	826	107	3561	1355	175	5596	2116	273	9164	3466	448									
150	924	350	42	1650	625	75	2574	975	117	4224	1599	192	6600	2499	299	10800	4092	490									
175	1065	404	45	1901	720	81	2966	1124	126	4867	1844	207	7604	2881	323	12450	4719	530									
200	1206	457	48	2152	816	86	3358	1273	135	5510	2089	221	8609	3264	346	14090	5345	566									
225	1346	511	51	2403	912	92	3750	1422	143	6153	2334	235	9613	3646	367	15740	5971	601									
250	1487	564	54	2654	1007	97	4141	1571	151	6796	2576	247	10610	4028	387	17380	6598	633									
275	1628	618	57	2905	1103	101	4533	1720	158	7439	2823	259	11620	4411	405	19030	7224	664									
300	1768	671	59	3157	1198	106	4925	1870	165	8082	3068	271	12620	4793	423	20670	7850	693									
325	1909	725	62	3408	1294	110	5317	2019	172	8725	3313	282	13630	5176	441	22320	8476	722									
350	2050	778	64	3659	1390	114	5709	2168	178	9367	3557	293	14630	5558	457	23960	9103	749									
375	2190	832	66	3910	1470	118	6100	2317	185	10010	3802	303	15630	5941	473	25610	9729	775									
400	2331	886	68	4161	1561	122	6492	2466	191	10650	4047	313	16640	6323	489	27250	10350	801									
425	2472	939	71	4412	1676	126	6884	2615	197	11290	4292	323	17640	6705	504	28900	10980	825									
450	2612	993	73	4663	1772	130	7276	2765	202	11930	4536	332	18650	7088	519	30540	11600	849									
475	2753	1046	75	4914	1868	133	7667	2914	208	12580	4781	341	19650	7470	533	32190	12230	873									
500	2894	1100	77	5166	1953	137	8059	3063	213	13220	5026	350	20660	7853	547	33830	12860	895									
525	3034	1153	78	5417	2059	140	8451	3212	218	13860	5271	359															
550	3175	1207	80	5668	2154	143	8843	3361	224	14510	5516	367															
575	3316	1260	82	5919	2250	147	9235	3510	229	15150	5760	375															
600	3456	1314	84	6170	2346	150	9626	3659	234	15790	6005	383															
625	3597	1367	86	6421	2441	153																					
650	3738	1421	87	6672	2537	156																					
675	3878	1475	89	6923	2632	159																					
700	4019	1528	91	7174	2728	162																					
725	4160	1582	92	7425	2824	165																					
750	4300	1635	94	7677	2919	167																					
775	4441	1689	95	7928	3015	170																					
800	4582	1742	97	8179	3110	173																					
825	4722	1796	98	8430	3206	176																					
850	4863	1849	100	8681	3302	178																					
875	5004	1903	101	8932	3397	181																					
900	5144	1957	103	9183	3493	183																					

### LIQUID OVERPRESSURE FACTORS

To determine liquid capacity at other than 10% accumulation multiply by the following:

1.066 = 25% acc.

1.045 = 20% acc.

1.022 = 15% acc.

Approx. 1 PSIG Increments	5.6	6	2.1	—	10	11	4	—	16	17	6	—	25	27	10	—	40	43	15	—	66	70	25	—
Approx. 5 PSIG Increments	28	30	11	—	50	54	19	—	78	84	30	—	129	137	49	—	201	214	76	—	329	351	125	—
Approx. 10 PSIG Increments	56	60	21	—	100	107	38	—	157	168	60	—	257	274	98	—	402	428	153	—	658	702	250	—

2 PSIG or 3% Acc. ASME Sec. I Steam

3 PSIG or 10% Acc. ASME Sec. VIII Air/Gas/Steam/Liquid

Valves set under 15 PSIG are not stamped with ASME Code Symbol stamp.

IMPORTANT: LonerGAN Valve Division is not liable for any damage resulting from misuse or misapplication of its products (see WARRANTY)



8222 Bluffton Road Box 2360  
Fort Wayne, Indiana 46801-2360  
219-747-1077  
FAX 219-747-7958

## VALVE INSTALLATION PRECAUTIONS

### MUSTS FOR INSTALLING PRESSURE RELIEVING SAFETY VALVES

1. No intervening stop valve is permitted between the system and/or piping and its protective relieving valve or valves, except per ASME SEC VIII UG-135 (e).
2. No intervening stop valve is permitted between the protective relieving valve and discharge port, except per ASME SEC VIII UG-135(e).
3. No valve discharge media is permitted to strike other piping, or other equipment, when discharge is to atmosphere. Also, discharge media must be aimed away from personnel platforms and all traffic areas.
4. All set pressure adjustments must be verified as falling within the design range for that valve spring. Consult factory. State laws dictate that valve seals be broken only by persons authorized to do so by ASME and the Lonergan Valve Division. Otherwise, valve warranties are void and laws breached. Consult factory.
5. When discharging more than one valve into a common header, excessive back pressure must be avoided. See ASME SEC VIII Appx. M-8.
6. Note the capacity of the relieving valve will always be increased or decreased proportionally with increase or decrease of set pressure.
7. TEST GAGS MUST BE REMOVED. Failure to do so renders the valve inoperable and, due to overpressure, may damage either the relieving valve or the system, or both.
8. Bonnet vents on all air, steam and vapor system valves must be left open - the shipping plugs must be removed.  
*Exception: conventional D Series valves must remain plugged as shipped.*
9. Pressure relief valves should be mounted in a vertical position. Installing a pressure relief valve in other than a vertical position will adversely affect operation in varying degrees as a result of consequent misalignment of moving parts. Also, warranties may be voided. Upside-down mounted valves should be provided with ample drainage of accumulated liquids from all sections of the valve.
10. Prior to all installations, inlet connections-flanged or screwed-must be cleared of foreign matter. Any dirt entering the valve may damage valve seats. Use only wrench flats when securing screw-connected valves.
11. Should leakage be detected from a newly installed valve, first assume the cause to be from shipping and handling or installation procedures. Apply pressure to the inlet side equal to 75% of operating pressure so that the lift lever can be manually activated, thus operating the valve. For valves without lift levers, system pressure may be allowed to rise to the point of valve operation. In most instances, the valve will properly reseat and the leakage will stop.
12. Absolute tightness at seat surfaces is difficult to achieve. Valve manufacturers adhere to a commercial seat tightness standard - API Standard 527. Manufacturers customarily make preshipment checks. Users are cautioned, however, to recheck tightness before first use and after cleaning, repairing and testing. Subsequent rough handling can undo seat tightness making the valve leak when in service. Careful transport during shipping, maintenance and installation is required. Do not bump, drop or scratch valve parts. Misalignment of movable internals may occur. Other factors causing leakage are: piping strains from inflexible supports, or the absence of support for the discharge piping. Leakage is self-aggravating, contributing to seat damage through erosion or corrosion.
13. Galling which occurs in the absence of corrosion or foreign matter contamination, may be traced to valve chatter. Chatter may be a result of improper piping at valve inlet or outlet, or oversizing the valve.
14. Temperature and corrosion effects on valve materials are very important to any safety relief valve application. Disregard of these critical considerations may damage or cause malfunction of the safety relief valve.
15. Minimum differential between operating pressure and set pressure: 5 psi up to 70 psi; set 10% from 71 to 1000 psi; 7% over 1000 psi. See ASME Sec. VIII Appx. M-M11C.
16. ASME-type safety valves must be equipped with lift levers for all air, steam and hot water (above 140°F) service.
17. Upon installation or after repair, the proper valve set pressure must be verified. Also, pressure gauges should be calibrated periodically, insuring proper system readout.
18. Any water leg between the valve and gauge must be compensated for. Otherwise, incorrect pressure readout will result.
19. Pressure relief valves left on-line during extended shutdowns should be inspected and tested before resuming service. Certain conditions or acts which often occur during long, unattended idle periods such as, corrosion, fouling or tampering, may prevent the device from performing properly. Where a change in operating conditions follows a shutdown, the inspection interval must be reviewed.

### WARRANTY

Seller's valves are guaranteed to be free from defects in material and workmanship for one (1) year from date of shipment. Upon Seller's written consent, any valve claimed defective may be returned to Seller, transportation charges prepaid, for examination. If, in Seller's opinion, the valve is defective, it will be repaired or replaced, as Seller may designate, F.O.B. the manufacturing plant. Under no circumstances does Seller assume responsibility for consequential or incidental damages, nor will Seller accept claims for labor, repairs or other expenses. In addition, Seller does not assume responsibility for repair or replacement of any valve, the necessity for which is occasioned by the improper application, installation, sale, maintenance, use or operation of such valve. SELLER MAKES NO WARRANTY AS TO MERCHANTABILITY OR AS TO FITNESS OF PRODUCTS FOR A PARTICULAR PURPOSE EXCEPT AS STATED ABOVE.

All goods are sold F.O.B. our plant. Unless otherwise expressly stated, the routing and freight allowance rate shall be as normally used by the Seller.

All goods are shipped at Buyer's risk. If Purchaser gives the Transportation Company a clean receipt for damaged goods or for shipment upon which there are shortages, Purchaser does so at his own risk. We are NOT RESPONSIBLE FOR goods damaged or lost in transit

# ***APPENDIX B***

*VAPORIZER SPECIFICATIONS*

*and*

*TECHNICAL INFORMATION*

# RECOMMENDED SPARES DIAGRAM

MODEL: 2.5 - 5# & 8#; MODELS: 7.0, V10.5 - 5#, 8#, 12#; MODEL: 9.0 - 12#

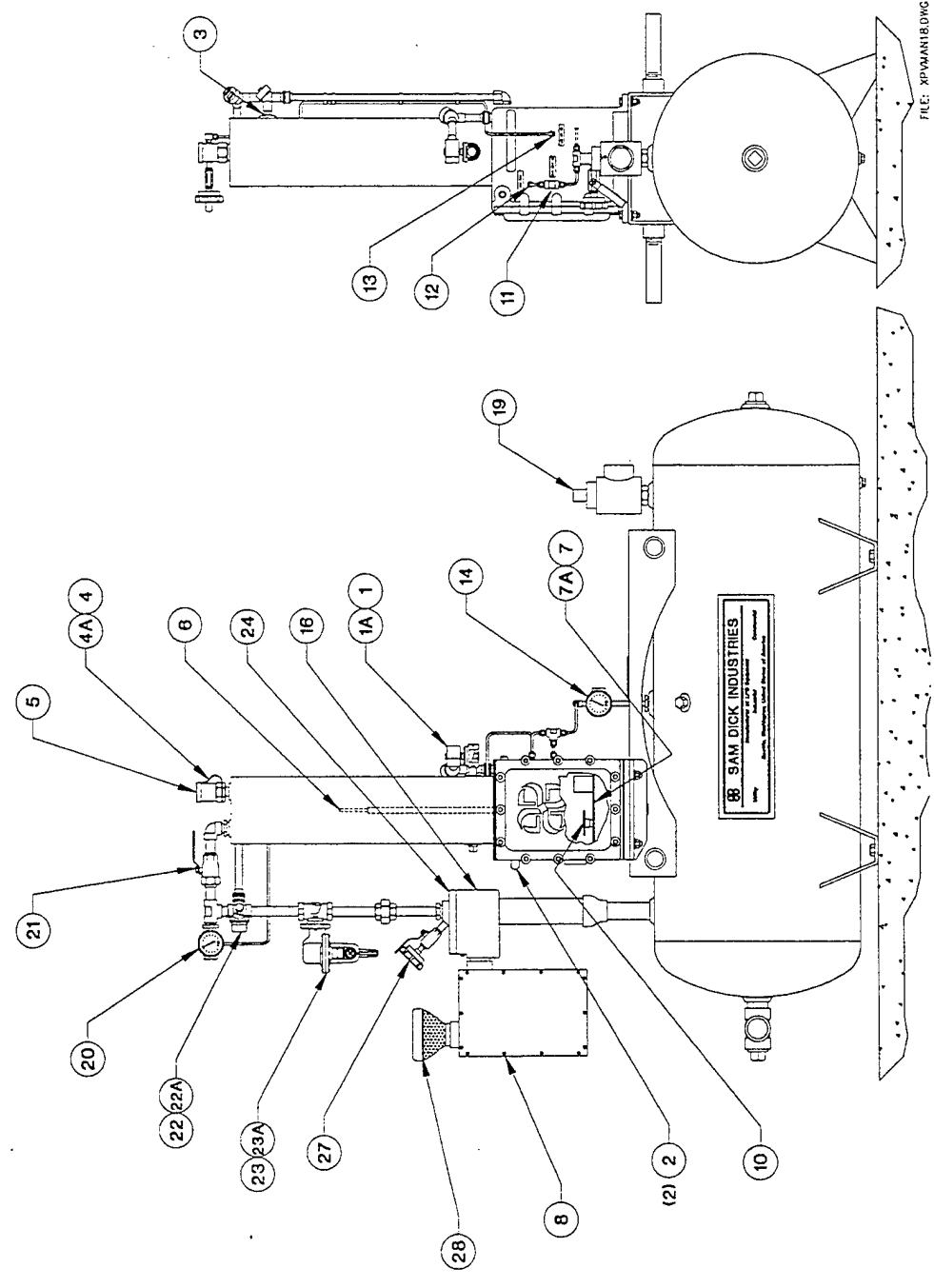

FILE: XPMWANTB.DWG

**RECOMMENDED SPARES DIAGRAM**  
**MODEL: 13.0 -10#; MODELS: 14.0 - 5# & 8#**

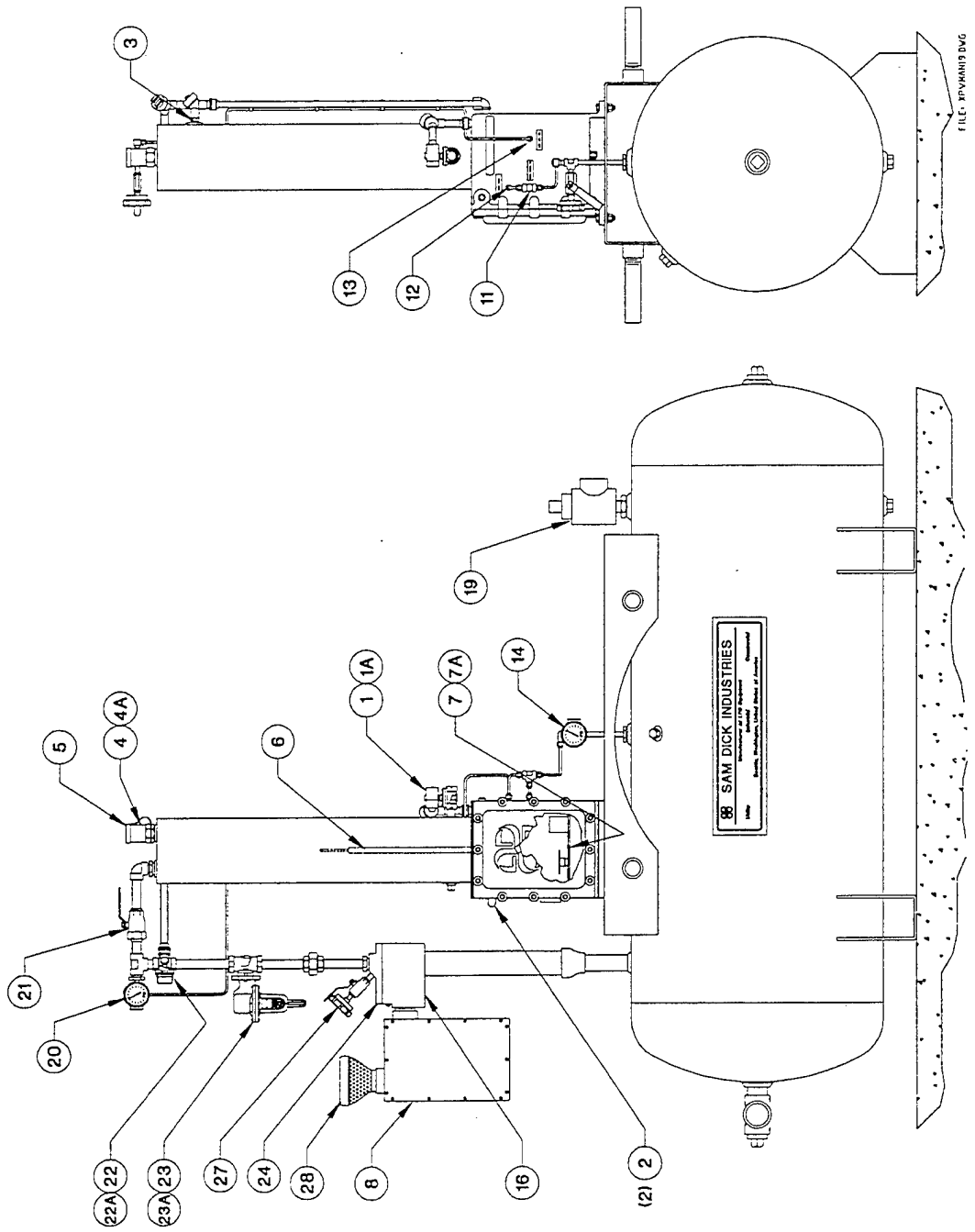

**RECOMMENDED SPARES DIAGRAM**  
**MODELS: 14.0 - 12# & 18.0 - 12#; MODEL: 21.0 - 5#, 8#, 12#**

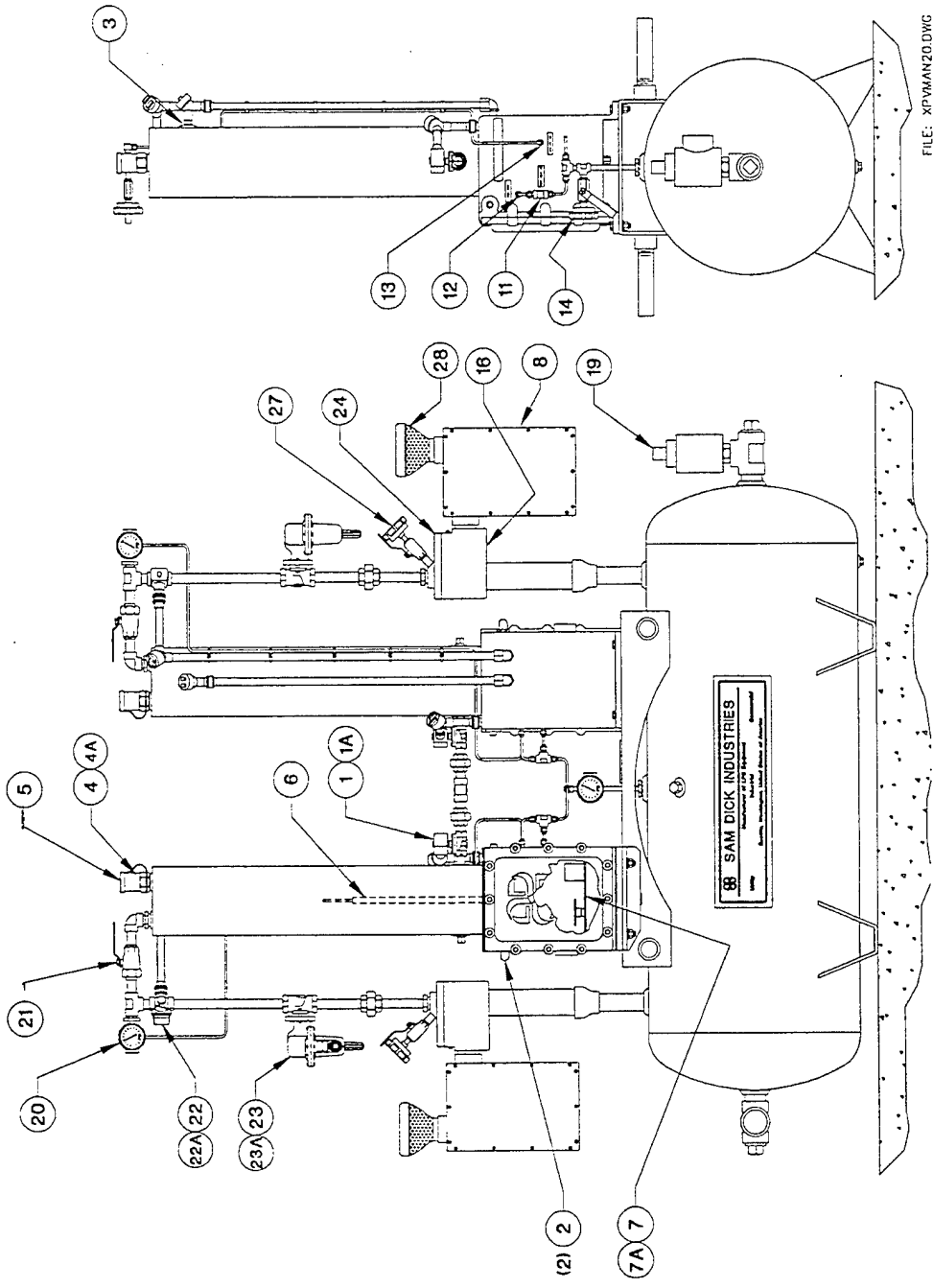

FILE: XPMAN20.DWG

**RECOMMENDED SPARES DIAGRAM**  
**MODEL: 26.0 -10#; MODEL: 28.0 - 5# & 8#**

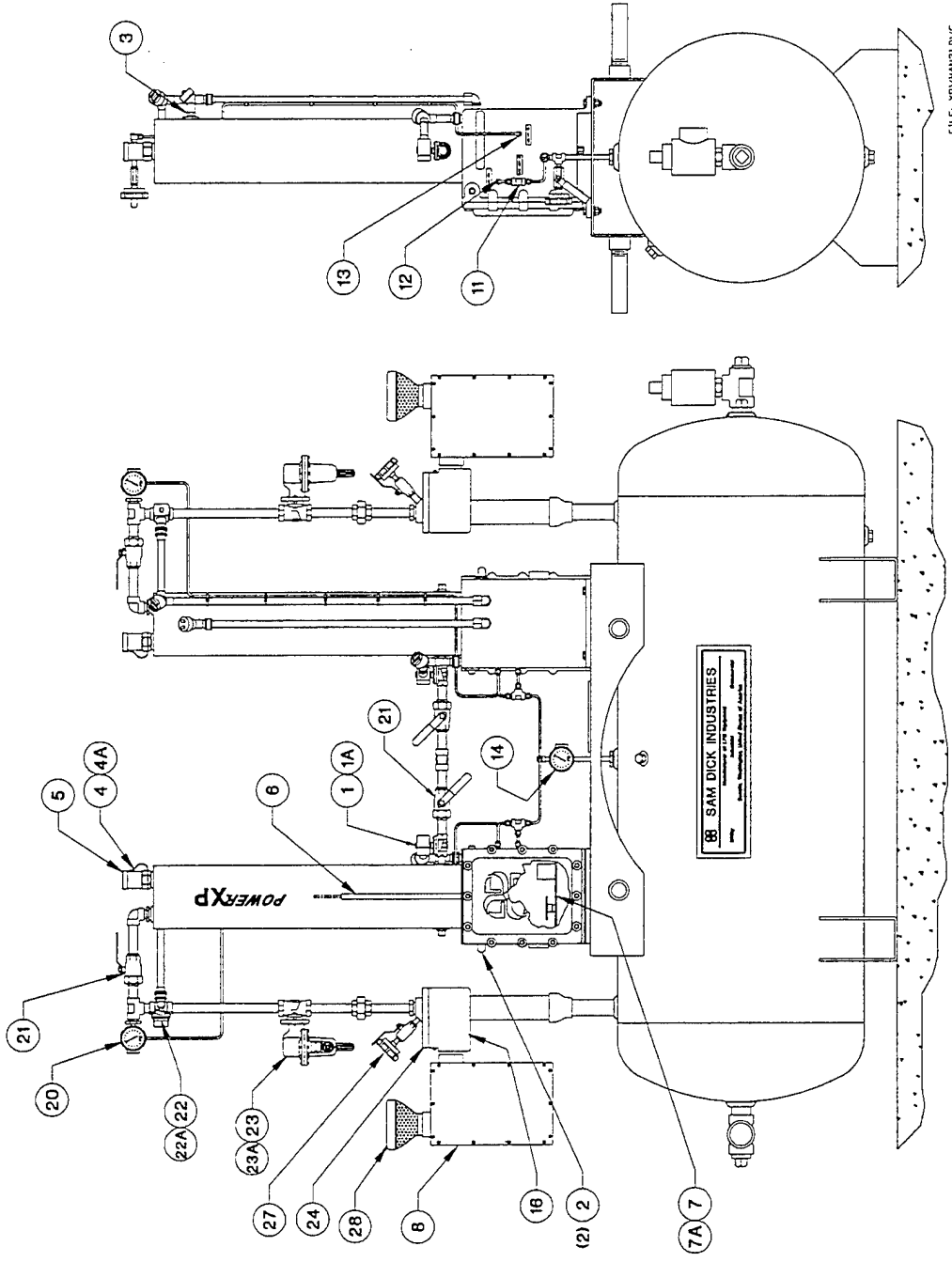

FILE: XPVWV21.DWG

# RECOMMENDED SPARES DIAGRAM

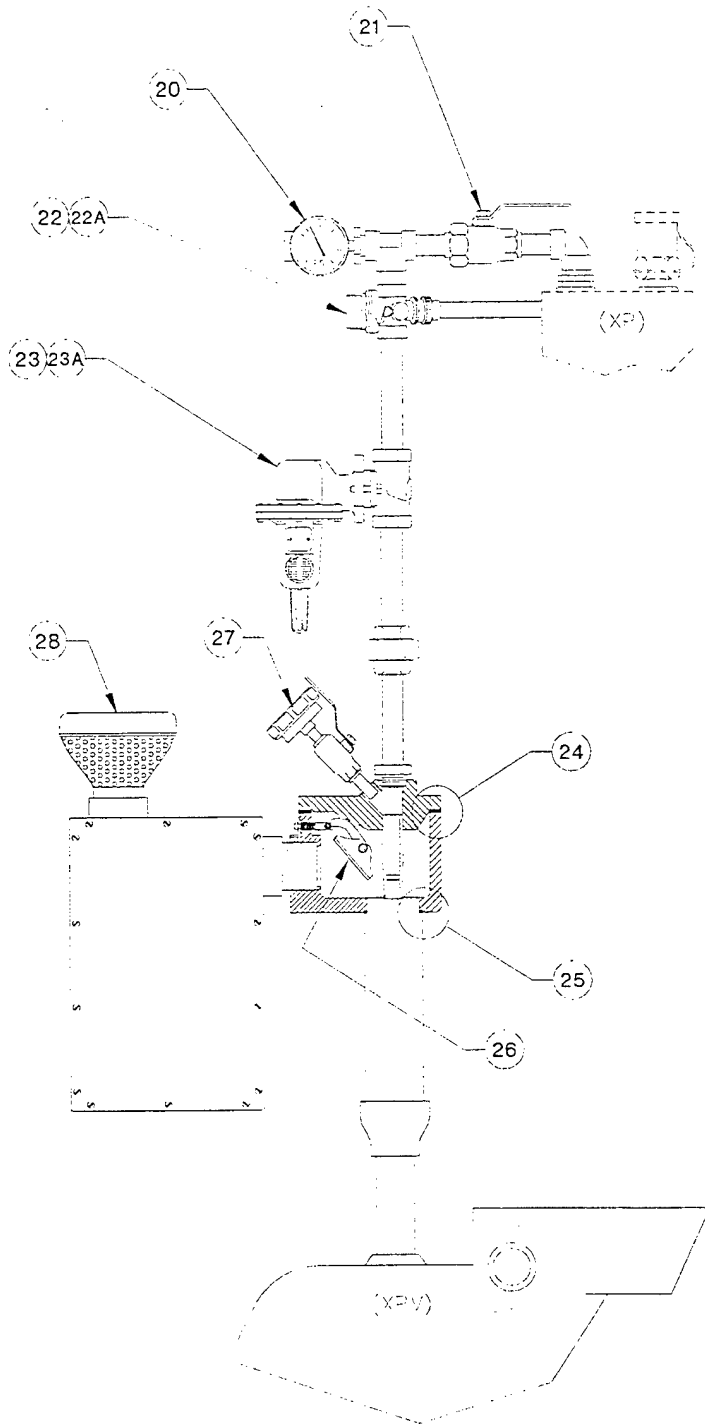

# RECOMMENDED SPARES DIAGRAM - CONTROL BOX

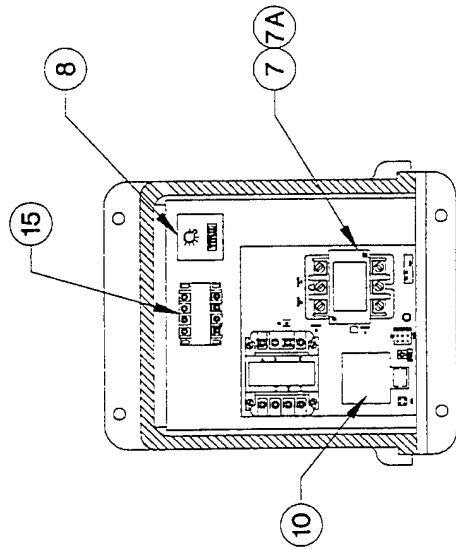

SECTION A-A

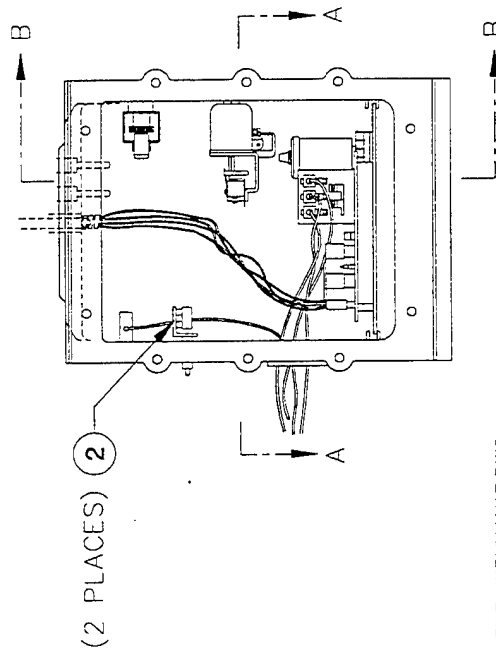

SECTION B-B

FILE: XPVMA17.DWG

**XPV Packaged Vaporizing/Mixing System**  
**Recommended Spare Parts and Accessories**



...a subsidiary of Eclipse, Inc.

REPLACEMENT PARTS		MODEL TYPE AND SIZE													
		5#							8#						
ITEM	DESCRIPTION	2.5	5.0	7.0	10.5	14.0	21.0	28.0	2.5	5.0	7.0	10.5	14.0	21.0	28.0
1	Valve, Inlet Solenoid	36110				36111			36110				36111		
*1A	Repair Kit, Inlet Solenoid Valve	40285				40287			40285				40287		
2	Switch, Start/Stop, Exp.				30887							30887			
*3	Switch, Liquid Level				30897							30897			
4	Valve, Pressure Relief (250 PSIG)				30747							30747			
4A	Valve, Pressure Relief (CA version)				30558							30558			
5	Rain Cap (for use without enclosure)				31017							31017			
	Rain Cap (for use with enclosure)				30570							30570			
*6	RTD Temperature Sensor														
	Control Circuit Board 208V/240V	52712							52712						
7	Control Circuit Board 380V/415V				52713							52713			
	Control Circuit Board 440V/480V				52714							52714			
7A	Relay, Heater Control				52603							52603			
8	Relay, Time Delay (Prog)				52625							52625			
9	Pipe Away Adapter (for item 4)				30752							30752			
*11	Switch, Pressure, Venturi Control				35539							35539			
12	Switch, Pressure, High Mixed Gas				36081							36081			
13	Switch, Pressure, Low Vapor				36118							36118			
14	Gauge, Pressure, 0-30 PSI ↑				30688							30688			
	Transformer, Venturi Circuit, 208V/240V	52229							52229						
15	Transformer, Venturi Circuit, 380V/415V				52151							52151			
	Transformer, Venturi Circuit, 440V/480V				52526							52526			
16	Venturi Housing (Body Only) ↑				20124							20124			
17	Rain Cap (Surge Tank Relief) ↑				32044							32044			
18	Silencer ↑				36080							36080			

See variable parts section on page 2

**XPV Packaged Vaporizing/Mixing System  
Recommended Spare Parts and Accessories**



REPLACEMENT PARTS		MODEL TYPE AND SIZE													
		5#						8#							
ITEM	DESCRIPTION	2.5	5.0	7.0	10.5	14.0	21.0	28.0	2.5	5.0	7.0	10.5	14.0	21.0	28.0
19	Valve, Relief (Surge Tank)	31304													
20	Gauge, Pressure, 0-300 PSI	30641													
21	Valve, Union Ball, 3/4" (Outlet)	30705													
22	Valve, Solenoid, 3/4" (Venturi Control)	36111													
*22A	Repair Kit, Solenoid Valve (Venturi)	40287													
23	Regulator, 627	32851	32712	35668	32712	35668	32851	30741							
*23A	Repair Kit, Regulator - 627	40022													
24	Gasket, Venturi Housing	20122													
25	O-Ring (diffuser)	31051													
*26 <sup>1</sup>	Venturi Check Valve Rebuild Kit	40490													
27	Gauge, Pressure, 0-100 PSI	30638													
28	Air Inlet Screen	31016													
<b>ACCESSORIES</b>															
	Remote Control Panel	52141													
	Strainer														
	Auto Restart	52175													
<b>VARIABLE PARTS</b>															
<b>VAPORIZER MODEL</b>															
ITEM	DESCRIPTION	XP80S	XP120S	XP160S											
*6	RTD Temperature Sensor	35682	36020	36024											

<sup>1</sup> Venturi check valve rebuild kit includes: Clevis, Acorn nut, Check valve, Pivot arm, Pivot bolts and hardware, and Venturi HSG gasket  
\*SDI recommends that these spare parts be kept on hand by the customer

† XPV only

REPLACEMENT PARTS		MODEL TYPE AND SIZE											
		10#						12#					
ITEM	DESCRIPTION	9.0	13.0	18.0	26.0	5.0	7.0	9.0	10.5	14.0	18.0	21.0	
1	Valve, Inlet Solenoid		36111			36110			36111				
*1A	Repair Kit, Inlet Solenoid Valve		40287			40285			40287				
2	Switch, Start/Stop, Exp.		30887						30887				
*3	Switch, Liquid Level		30897						30897				
4	Valve, Pressure Relief (250 PSIG)		30747						30747				
4A	Valve, Pressure Relief (CA version)		30558						30558				
5	Rain Cap (for use without enclosure)		31017						31017				
	Rain Cap (for use with enclosure)		30570						30570				
*6	RTD Temperature Sensor	See variable parts section on page 2											
	Control Circuit Board 208V/240V					52712							
7	Control Circuit Board 380V/415V		52713						52713				
	Control Circuit Board 440V/480V		52714						52714				
7A	Relay, Heater Control		52603						52603				
8	Relay, Time Delay (Prog)		52625						52625				
9	Pipe Away Adapter (for item 4)		30752						30752				
*11	Switch, Pressure, Venturi Control		35539						35539				
12	Switch, Pressure, High Mixed Gas		36082						36082				
13	Switch, Pressure, Low Vapor		36106						36106				
14	Gauge, Pressure, 0-30 PSI		30635						30635				
	Transformer, Venturi Circuit, 208V/240V					52229							
15	Transformer, Venturi Circuit, 380V/415V		52151						52151				
	Transformer, Venturi Circuit, 440V/480V		52526						52526				
16	Venturi Housing (Body Only)		20124						20124				
17	Rain Cap (Surge Tank Relief)†		32044						32044				
18	Silencer †		36080						36080				

**XPV Packaged Vaporizing/Mixing System  
Recommended Spare Parts and Accessories**



REPLACEMENT PARTS		MODEL TYPE AND SIZE										
		10#			12#			13#				
ITEM	DESCRIPTION	9.0	13.0	18.0	26.0	5.0	7.0	9.0	10.5	14.0	18.0	21.0
19	Valve, Relief (Surge Tank)		31304						31304			
20	Gauge, Pressure, 0-300 PSI		30641						30641			
21	Valve, Union Ball, 3/4" (Outlet)		30705						30705			
22	Valve, Solenoid, 3/4" (Venturi Control)		36060						36060			
*22A	Repair Kit, Solenoid Valve (Venturi)		40287						40287			
23	Regulator, 627		30741			36063		30741	36063		30741	
*23A	Repair Kit, Regulator - 627		40022						40023			
24	Gasket, Venturi Housing		20122						20122			
25	O-Ring (diffuser)		31051						31051			
*26 <sup>1</sup>	Venturi Check Valve Rebuild Kit		40490						40490			
27	Gauge, Pressure, 0-100 PSI		30638						30638			
28	Air Inlet Screen		31016						31016			
<b>ACCESSORIES</b>												
	Remote Control Panel		52141						52141			
	Strainer		30654		30655			30654				30655
	Auto Restart		52175						52175			
<b>VARIABLE PARTS</b>												
<b>VAPORIZER MODEL</b>												
ITEM	DESCRIPTION	XP80S	XP120S	XP160S								
*6	RTD Temperature Sensor	35682	36020	36024								

<sup>1</sup>Venturi check valve rebuild kit includes: Clevis, Acorn nut, Check valve, Pivot arm, Pivot bolts and hardware, and Venturi HSG gasket  
\*SDI recommends that these spare parts be kept on hand by the customer

**DATA SHEET**  
**XPV PACKAGED VAPORIZING/MIXING SYSTEM**

Model: XPV 5.0-12 Serial Number: 9900207 Year Built: 1999  
Type of Service: PROPANE (Vap.) PROPANE/AIR (Mixing)  
Customer Name: AUTOMATED ENERGY SYSTEMS Job Number: 14343E  
Options: \_\_\_\_\_

**ELECTRICAL SPECIFICATIONS:**

Electrical Drawing: 2001-7004 Rev. F  
Electrical Bussing Diagram: 0620-7012 Rev. B  
Input Electrical Power: 240 Volts, 58 Amps (Line Current)  
3 Phase, 24 K.W.  
3 Wire, 50-60 Hz.  
Electrical Supply Conduit Connection: 1 1/4 " FNPT  
Electrical Enclosure Rating: NEMA 4

All electrical wiring and controls meet or exceed NFPA 70 requirements for Class 1, Division 1, Group D equipment

**VAPORIZER SPECIFICATIONS:**

Vaporizer Model: XP 80 S  
Capacity: 80 GPH @ 0 Deg. F. & 100 PSIG 5,000,000 BTU/HR  
Heater Resistance: 4.8 ohms Wire to Wire (at relay) 14.5 ohms Individual Element  
Operating Temperature (Internal): 200-210 Deg. F.  
High Temperature Limit (Internal): 360 Deg. F.  
Starting Temperature (Internal): 130 Deg. F.  
External Temperature classification: T3C  
Pressure Vessel Rating: 250 PSIG MAWP  
Heat Exchange Area: 4.3 Square Feet  
Relief Valve Setting: 250 PSIG

\*Factory Mutual Research (FM) Approved

Vaporizer meets or exceeds NFPA Pamphlet 58 for electric vaporizers and may be installed in compliance with indirect fired vaporizer limitations.

XPV PACKAGED VAPORIZING/MIXING SYSTEM (cont.)

LPG/AIR MIXER SPECIFICATIONS:

\*Mixing Capacity: 5,000,000 BTU/Hr. @ 135 PSIG Motive Pressure  
LPG/Air Discharge Pressure: 12 PSIG  
LPG Pressure Required: 140 PSIG (minimum)  
Motive Pressure: 135 PSIG  
Low Vapor Pressure Switch Setting: 111 PSIG  
High Tank Pressure Switch Setting: 15 PSIG  
Tank Relief Valve Setting: 50 PSIG  
Tank Size: 120 Gal., 16 Ft<sup>3</sup>

Tank is fabricated in accordance with ASME Section VIII, Division 1 and "U" code stamped.

MAWP 200 PSIG @ 650 Deg. F.

MDMT -20 Deg. F. @ 200 PSIG

Mixing system meets or exceeds NFPA Pamphlet 58 requirements for LPG/Air mixers.

CONNECTIONS:

Liquid Inlet 3/4" FNPT  
Mixed Gas Outlet: 2" FNPT

\*Mixing capacity (BTU/Hr.) is directly related to LPG motive pressure. All systems are pre-set at the factory within  $\pm 10\%$  of rated motive pressure. Additional field adjustment may be required due to varying operating conditions.

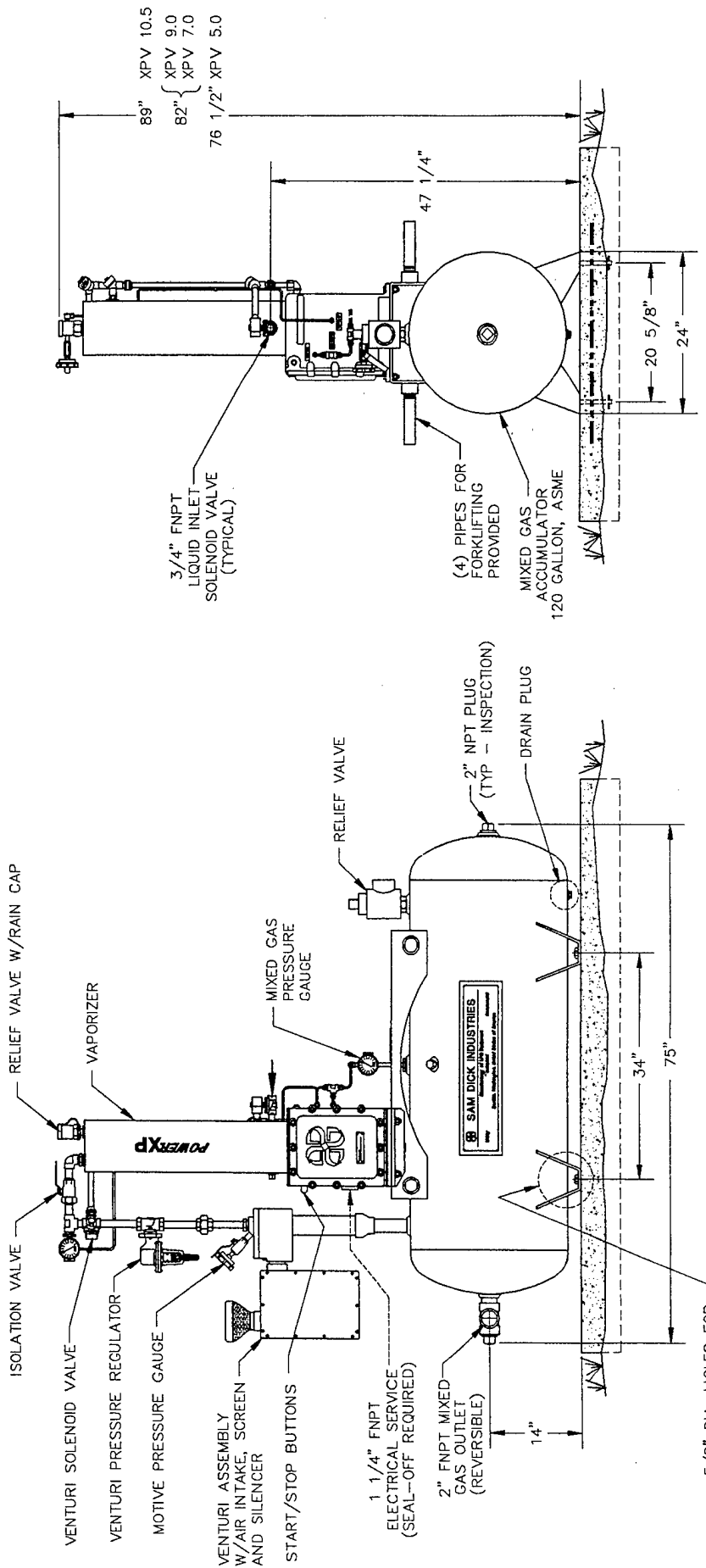

- NOTES**
1. FOR USE IN CLASS I DIV. 1 GROUP D LOCATIONS.
  2. FOR OUTDOOR INSTALLATION.
  3. MAXIMUM WORKING PRESSURE:  
 VAPORIZER(S): 250 PSIG  
 ACCUMULATOR: 50 PSIG  
 MEETS OR EXCEEDS NFPA 58 AND 70 REQUIREMENTS.
  4. SHIPPING WEIGHT (APPROX.):  
 MODEL 5.0 = 800 LBS  
 MODEL 7.0 = 850 LBS  
 MODEL 9.0 AND 10.5 = 900 LBS
  5. EXTERIOR PAINT "S.D.I. BLUE" PER S.D.I. PAINT SPEC. PS-2

**Sam Dick Industries**  
 1140 N.W. 46th ST, SEATTLE, WA, 98107  
 TEL: (206) 789-5410 FAX: (206) 789-5414

Drawn By: BRISSON Date: 6-6-94  
 Checked By: *ASB 11/4/98* Scale: NONE  
 Approved By: *ASB 11/5/98* Job No.:  
 C.A.D. File No.: SDI Part No.:

TITLE: PACKAGED VAPORIZING/  
 MIXING SYSTEM MODELS  
 5.0, 7.0, AND 10.5 - 12 PSIG  
 AND 9.0 - 10 AND 12 PSIG  
 EQUIPMENT DRAWING

DWG. NO.: 2001-6002

SIZE: B SH NO.: 1 OF 1 REV: E

This drawing is the property of SAM DICK INDUSTRIES and is not to be reproduced

REVISIONS		REV. BY
REV	DESCRIPTION	JLB
F	ADDED CONTACTOR DETAIL	10-24-97

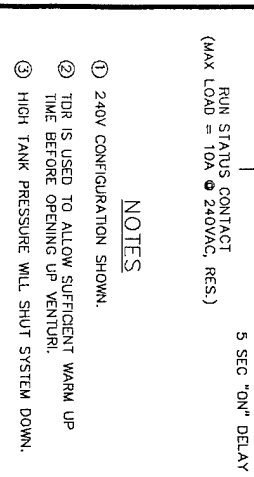
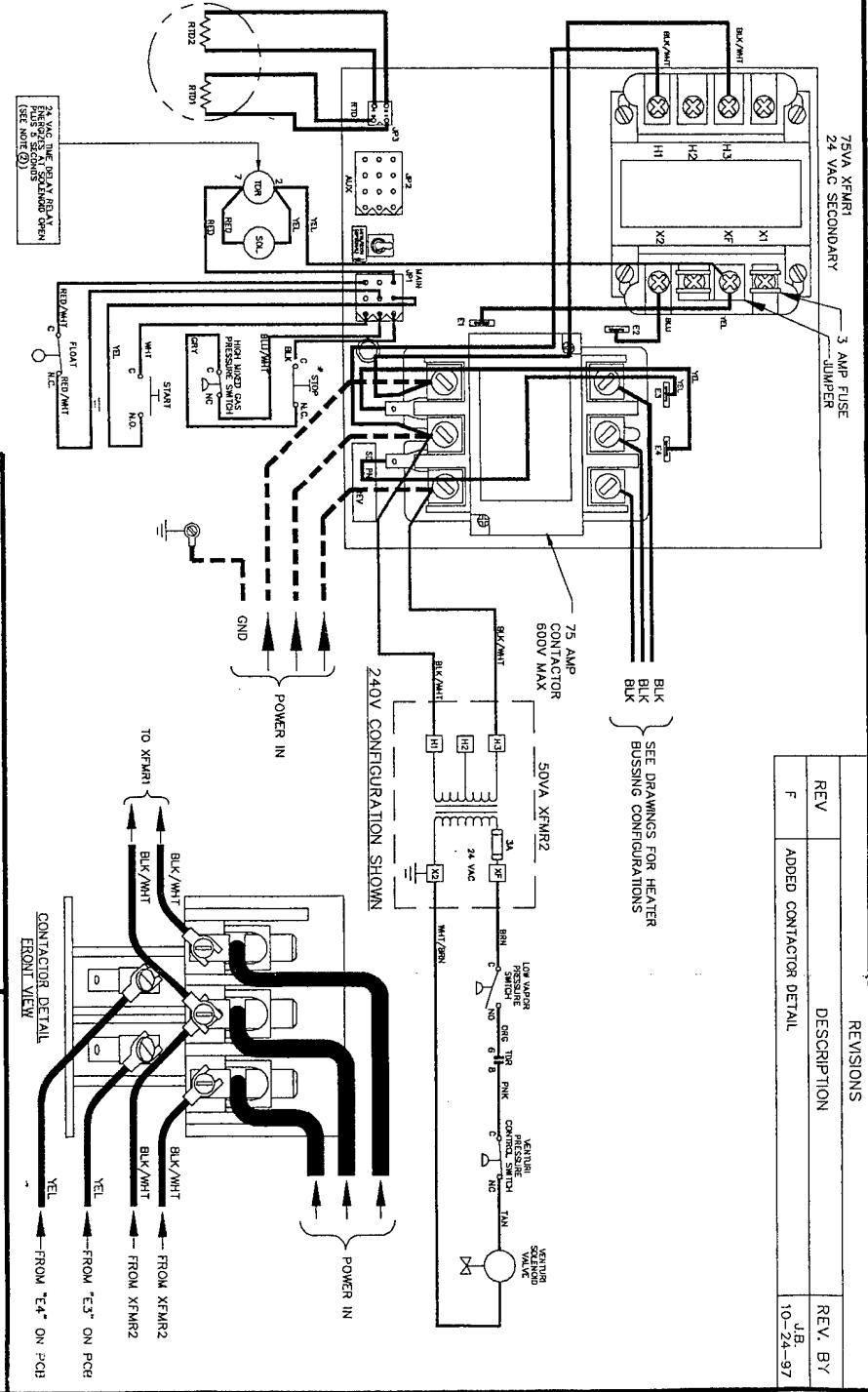
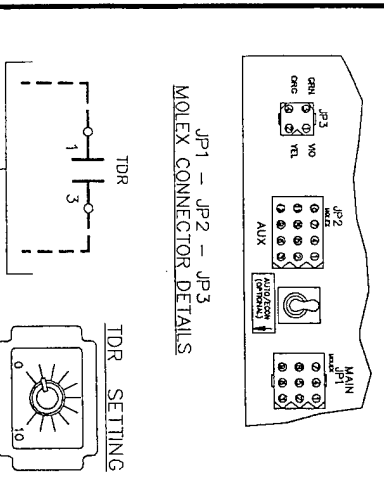
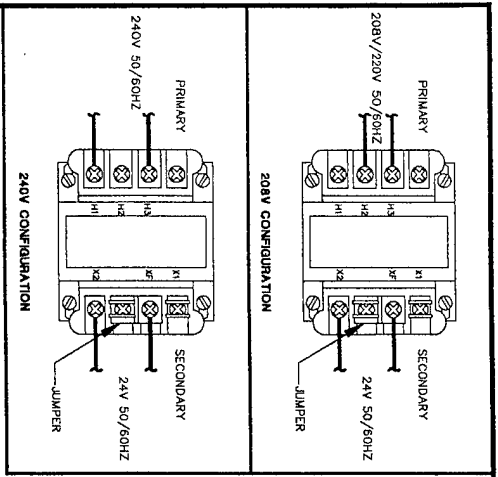

**Sam Dick Industries**

1140 N.W. 46th ST. SEATTLE, WA. 98107  
TEL: (206) 789-5410 FAX: (206) 789-5414

Drawn By: BRISSON  
Checked By: JLB  
Approved By: JLB  
Date: 8-16-93  
Scale: NONE  
Job No.: S.D.I. STD.  
S.D.I. Part No.:  
S.D.I. Part No.:

**"XPV" / "XPM" SYSTEM**  
WIRING DIAGRAM 208V THRU 240V  
3Ø POWER VERTICALS  
MODELS XP50 THRU XP160  
W/ 1 GUN VAPORAIRE

2001-7004

REV. BY: JLB  
REV. F

This drawing is the property of SAM DICK INDUSTRIES and is not to be reproduced  
nor used in any manner detrimental to our interests. All rights are reserved.

**TREE #4**  
**VAPORIZER STARTS AND HEATS UP, BUT VENTURI MIXER DOES NOT OPERATE**

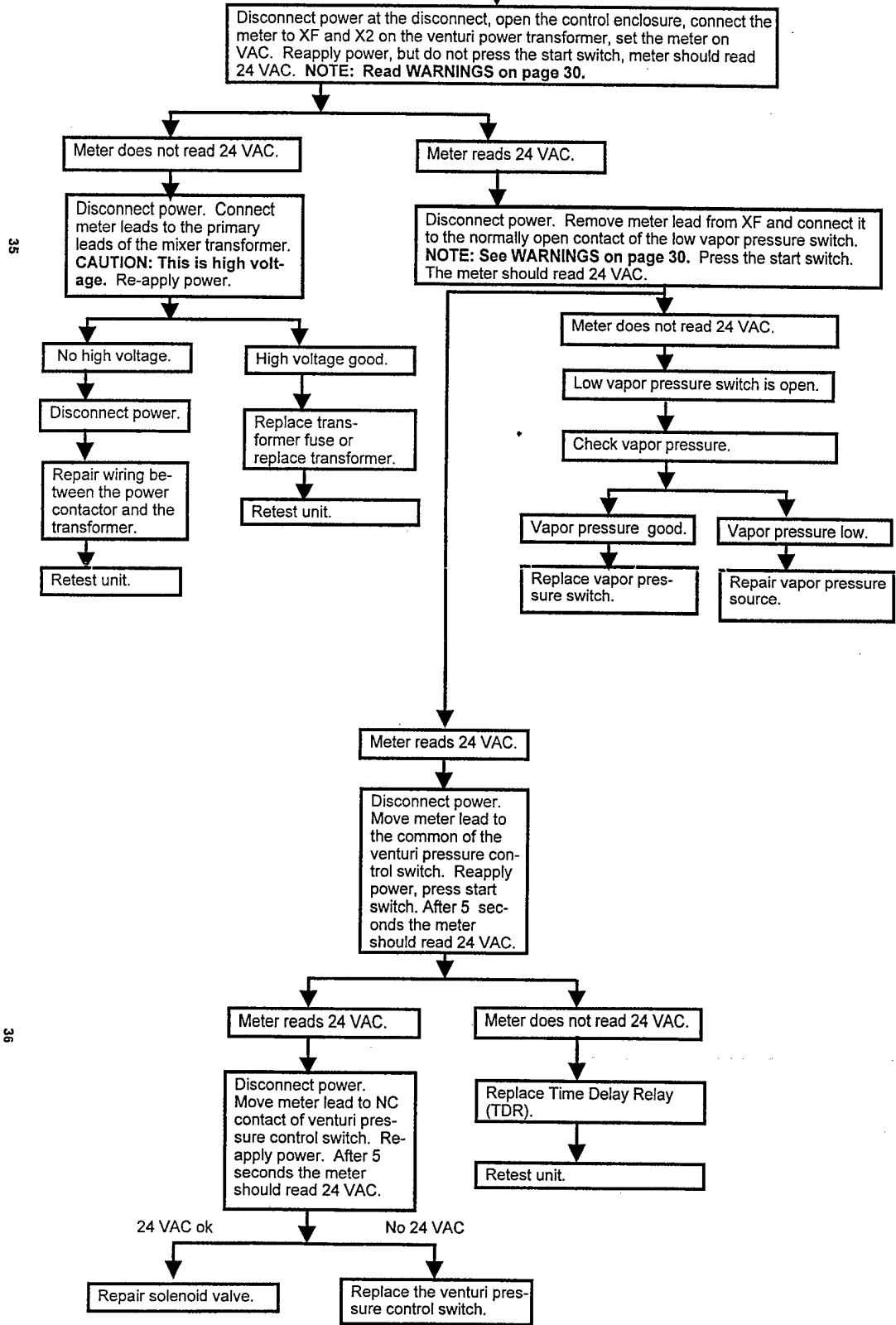

35

36

**TREE #2  
NO REACTION WHEN START SWITCH IS PRESSED**

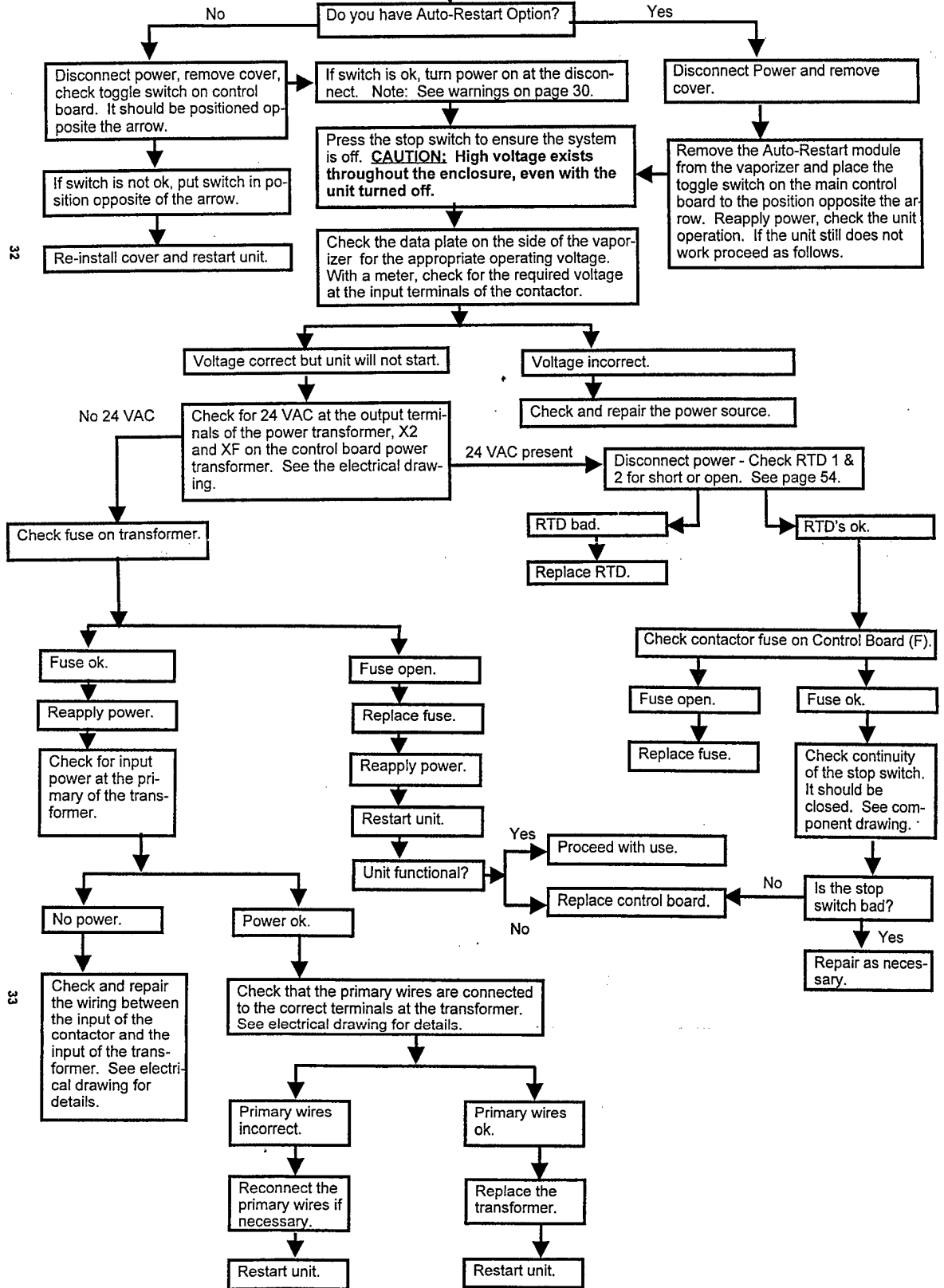

32

33

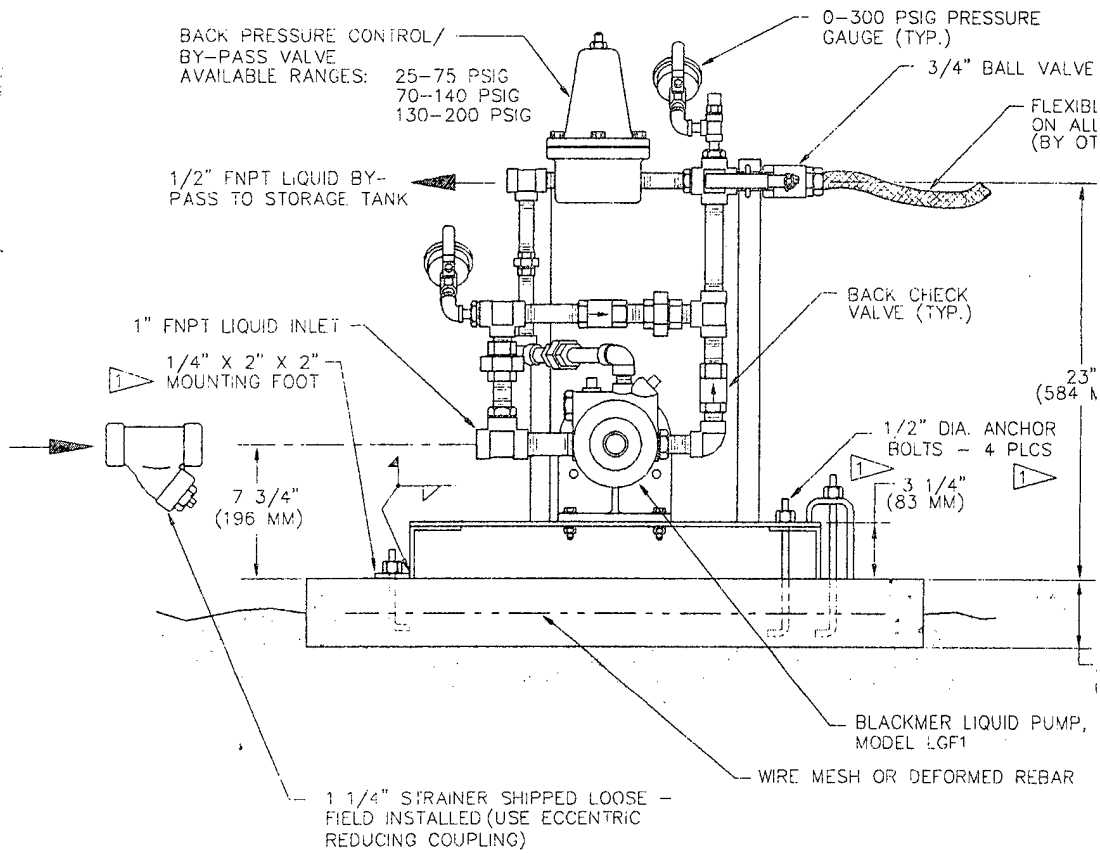
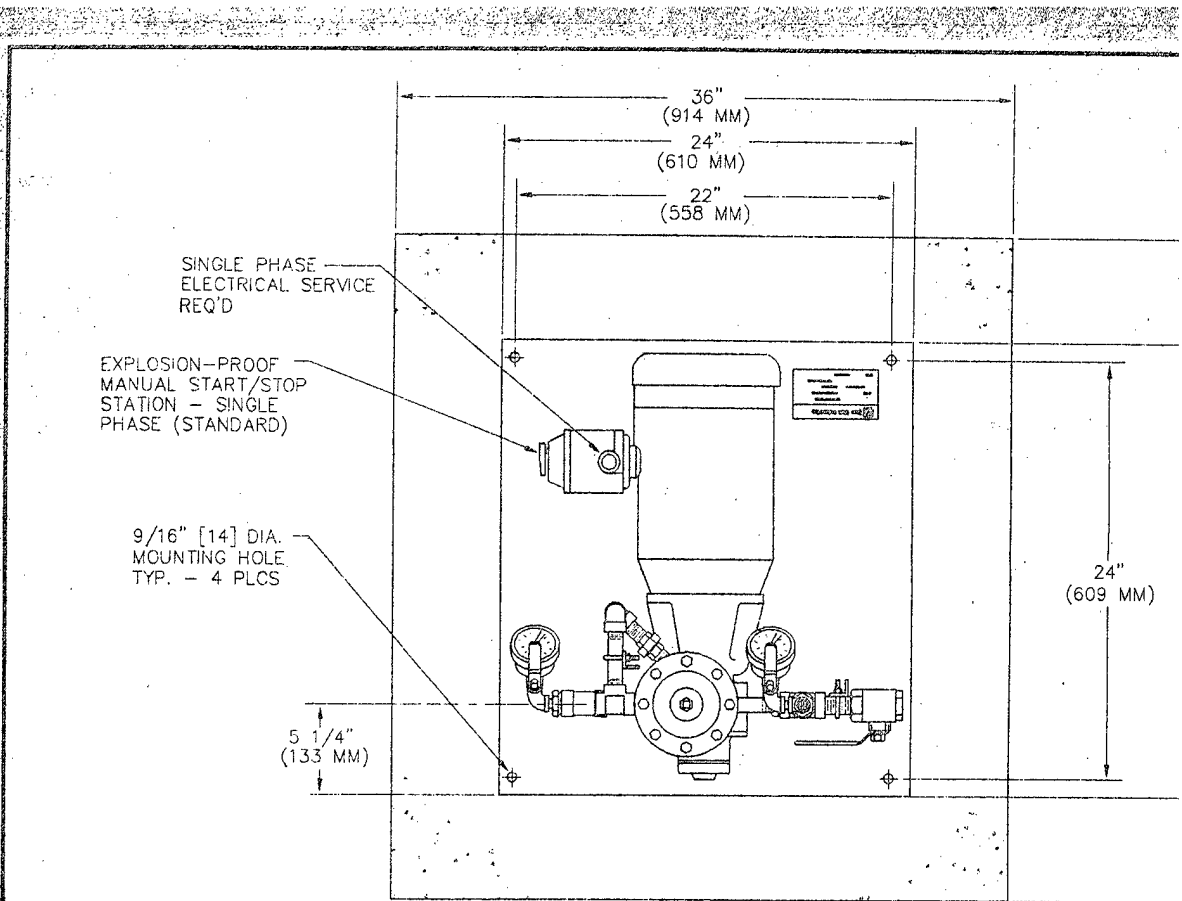

2 of 2

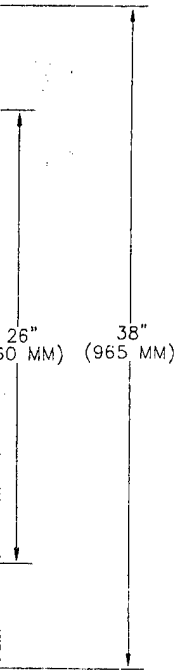

**NOTES**

- 1 RECOMMENDED ANCHORING METHODS
- 2 APPROX. SHIPPING WEIGHT: 200 LBS (91 KG)
- 3 DIMENSIONS SHOWN  $\pm 1/4"$
- 4 MEETS NFPA 70 REQUIREMENTS FOR CLASS I DIV 1 GROUP D
- 5 EXTERIOR: S.D.I. BLUE PER S.D.I. PAINT SPEC. PS-2.

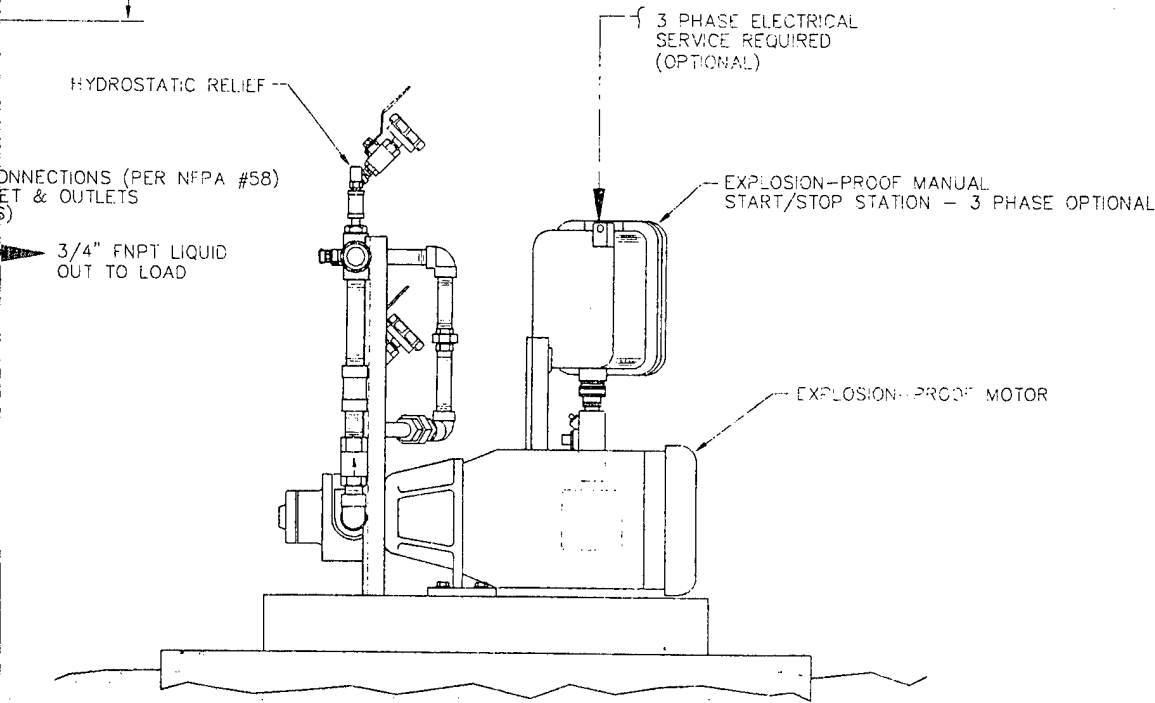

(IN, MM)

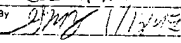
 <b>Sam Dick Industries</b> 1140 N.W. 46th ST, SEATTLE, WA 98107 TEL: (206) 789-5410 FAX: (206) 789-5414		TITLE <b>"STABILAIRE"          LIQUID PUMP          MODEL BS-1          EQUIPMENT DRAWING</b>	
Drawn By <b>G. ROPPE</b>	Date <b>12-11-92</b>	DWG NO. <b>1104-6001</b>	
Checked By <b>ELR 1/7/98</b>	Scale <b>NONE</b>	SIZE <b>C</b>	
Approved By 	Sub No. <b>S.D.I. STD.</b>		
C.A.D. File No.	S.D.I. Part No.	SHEETS <b>1 OF 1</b>	REV <b>E</b>

REV	INITIAL RE
A	
B	1) UP-DATE -- SEE PRE
C	1) UP-DA 2) ITEM 6 3) QTY ITE QTY ITE

- 1 ALL JOIN FOR USE
- 2 ITEM 37 & CHICO
- 3 VOLTAGE
- 4 LEAK CH WHEN AS
- 5 COMPLETE TAPE ALL
- 6 REMOVE
- 7 STRAP/NER FIRMLY
- 8 NOT A
- 9 MOUNTING (SEE PLA
- 10 SEE FOR A LENS

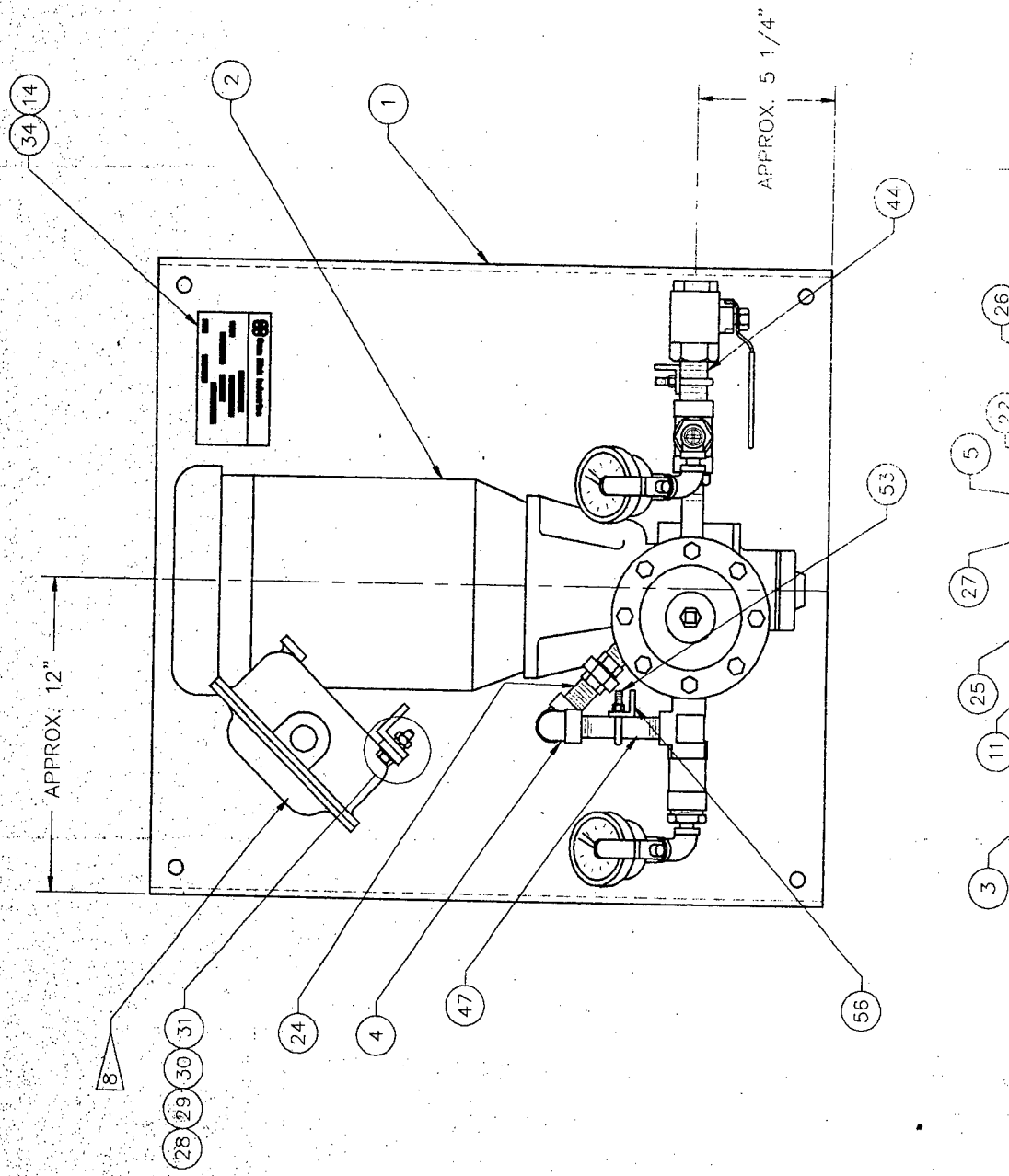

Handwritten mark: H J 01

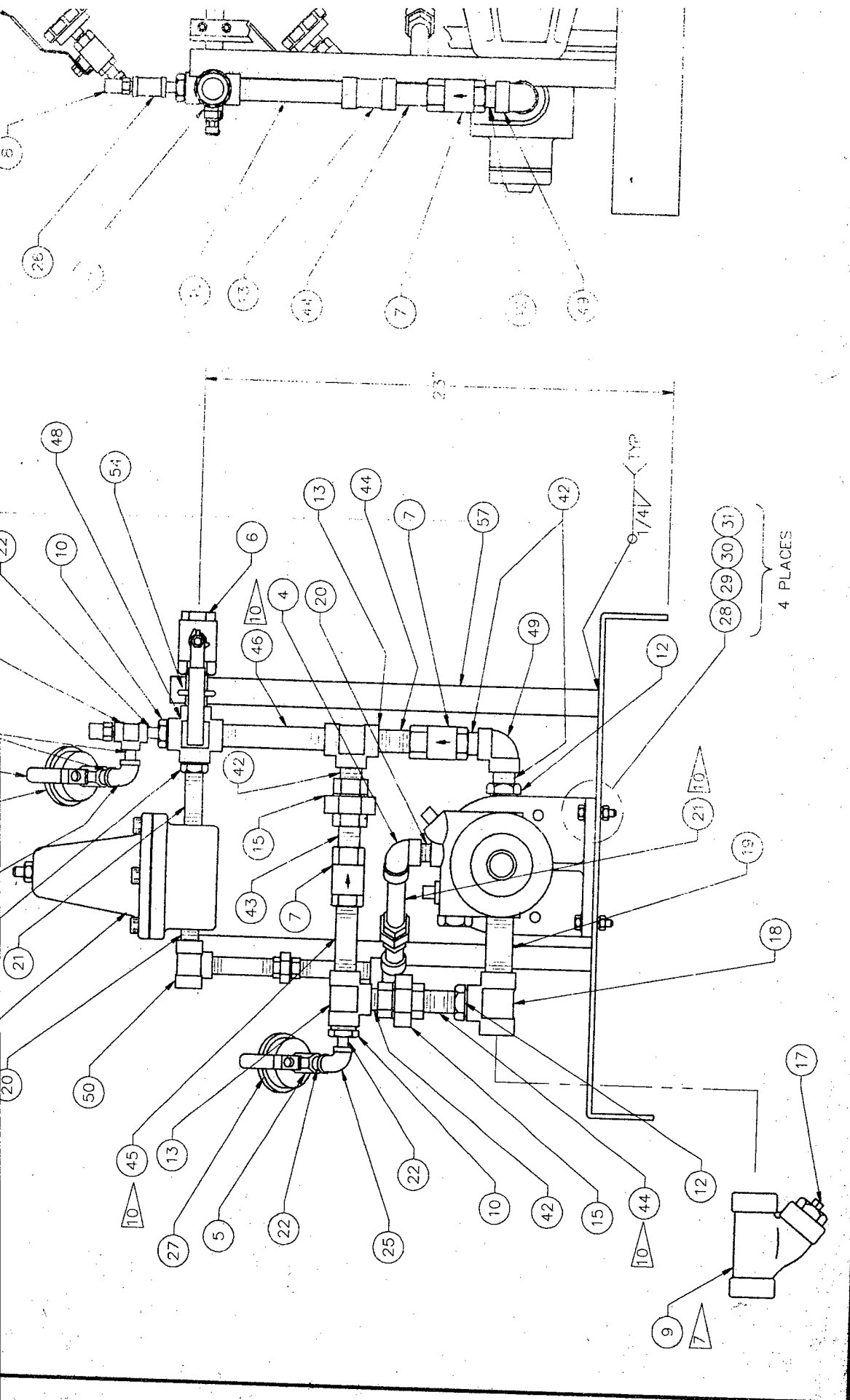

2 of 4

REVISIONS	REV. BY
DESCRIPTION	GLR 3-1-93
1. TO AS-BUILT CONFIGURATION REVISION FOR CONFIG. CHANGE	GLR 8-29-94
2. LATEST CONFIG. VALVE BALL VALVE P/N 30705 QTY OF ITEM 21 WAS 3, WAS 1	GLR 11-1-95

**NOTES**

1. BE SEALED WITH PIPE DOPE SUITABLE  
LPG.

2. LED W/CHICO X FIBER MAT'L  
ALING COMPOUND (ITEMS 51 & 52).

3. SPECIFIED BY ENGINEERING.

4. / AIR @ 150 PSIG & SOAP SOLUTION  
TEST IS COMPLETE.

5. IT IS TO BE PAINTED PER S.D.I./PS-2  
PLATES AND ITEMS TO REMAIN UNPAINTED.

6. TEST BEFORE SHIPPING.

7. BE SHIPPED W / UNIT ATTACH  
8. TO INSURE ARRIVAL.

9. 45° FROM MOTOR TO ALLOW  
SUPPORT ANGLE

10. FOR ORIENTATION

SPECIFIC INFORMATION.

REQ'D

3074

1	60706	ANGLE, 1/4" X 1 1/4" X 1 1/4" X 1 1/4" X 21" LONG	57
1	30512	ANGLE, 1/4" X 1" X 1" X 21" LONG	56
1	30039	NIPPLE, SCH. 80 BLK 1/2" NPT X 4 1/2" LONG	55
1	60050	"U" BOLT W/ NUTS FOR 3/4" PIPE	54
1	60049	"U" BOLT W/ NUTS FOR 1/2" PIPE	53
A/R	65030	CHICO X SEALING COMPOUND	52
A/R	65031	CHICO X FIBER MAT'L	51
1	30321	TEE, 1/2" FS 2000#	50
1	30383	ELBOW, 3/4" FS 2000#	49
1	30313	CROSS, 3/4" FS 2000#	48
2	30038	NIPPLE, SCH. 80 BLK 1/2" NPT X 4" LONG	47
1	30053	NIPPLE, SCH. 80 BLK 3/4" NPT X 6" LONG	46
1	30049	NIPPLE, SCH. 80 BLK 3/4" NPT X 4" LONG	45
3	30047	NIPPLE, SCH. 80 BLK 3/4" NPT X 3" LONG	44
1	30045	NIPPLE, SCH. 80 BLK 3/4" NPT X 2' LONG	43
4	30044	NIPPLE, SCH. 80 BLK 3/4" NPT X 1 1/2" LONG	42
A/R	9	WIRE	41
3/4 CR 6	65053	WIRE NUT	40
2	30401	NIPPLE, SCH. 40 GALV 1/2" NPT X 1 1/2"	39
3	9	OVER LOAD HEATERS	38
1	30457	CONDUIT SEAL OFF 1/2" FVF	37
1	30450	CONDUIT BUSHING 1" X 1/2"	36
1	9	MANUAL STARTER, 1HP/3PH	35
1	52517	S.D.I. PUMP NAMEPLATE	34
1	30513	ANGLE, 1/4 X 1 1/2 X 1 1/2 STEEL	33
1	60071	HEX NUT 5/16-18 ZINC PLATED	31
3	60036	LOCK WASHER 5/16" MDM SPLIT ZINC PLATED	30
5	60069	FLAT WASHER 5/16" SAE	29
5	60023	HEX HEAD BOLT 5/16-18 X 1 1/4" LONG	28
2	30639	GAUGE 0-300 PSI BKMT LIQ. EQUAL SCALE	27
1	30319	TEE, FS 2000# 1/2" NPT	

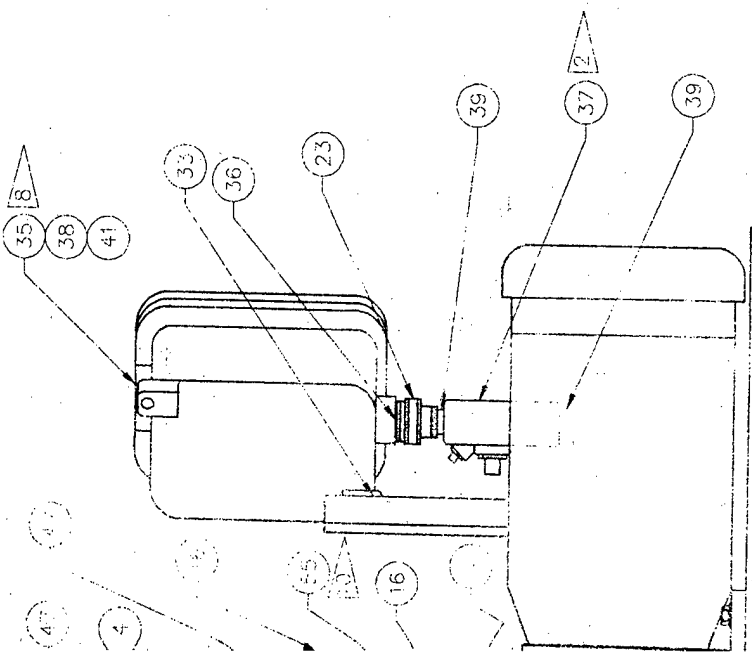

ITEM	DESCRIPTION	QTY	PART No.
25	ELBOW FS 2000# 90° 1/4" NPT FXF	2	30380
24	NIPPLE SCH 80 BLK 1/2" X 2" LONG	1	30034
23	SFR. CONDUIT UNION 1/2" M X F	5	30073
22	NIPPLE SCH 80 BLK 1/4" NPT X 1 1/2" LONG	2	30011
21	NIPPLE SCH 80 BLK 1/2" X 3 1/2" LONG	2	30037
20	NIPPLE SCH 80 BLK 1/2" NPT X 1 1/2" LONG	2	30039
19	NIPPLE SCH 80 BLK 1" NPT X 3 1/2" LONG	1	30728
18	TEE 1" FS 2000#	1	30729
17	BUSH. STEEL 3/4" NPT	2	30364
16	UNION FS 2000# STRAIGHT 1/2" NPT FXF	2	30365
15	UNION FS 2000# STRAIGHT 3/4" NPT FXF	4	30203
14	ALUM. RIVET AND MANDREL 1/8" DIA BOTTOM HEAD	2	30374
13	TEE FS 2000# 3/4" NPT	2	30105
12	PUSHING STEEL 1" X 3/4" NPT	2	30104
11	BUSHING STEEL 3/4" X 1/2" NPT	1	30657
10	BUSHING STEEL 3/4" X 1/2" NPT	2	30739
9	STRAINER 600 WTC 1 1/4"	2	30376
8	VALVE HYDRO RELIEF 1/4" 400 PSI	1	35019
7	VALVE CHECK 3/4" FXF BRONZE SFTST	2	30750
6	VALVE 3/4" BALL	3	30382
5	BALL VALVE 1/4" FXF	1	30383
4	FLANG 1/2" 3015 2000#	1	30384
3	VALVE ABSOLUTE RELIEF 1/2"	1	30385
2	PUMP W/MOTOR, BLACKMER MODEL 101	1	30386
1	BASE	1	30387

**Sam Dick Industries**

1140 NEW 46TH ST. SEVA E. WA.  
 TEL: (206) 759-5410 FAX: (206) 759-5411

Drawn By: G. ROPPE  
 Checked By: [Signature]  
 Date: 7/23/96

1104-2001

1 of 1

1104

# STABILAIR

**Liquid LPG Pump Packages**  
**Models: BS1 through BS3**

## OPERATION & MAINTENANCE MANUAL

Revision Date:

9-14-95



1140 N.W. 46th Street, Seattle, WA 98107, U.S.A.

TEL: (206) 789-5410

FAX: (206) 789-5414

FILE: BSMAN-94

P/N: 52631

## **WARNING!**

- Read this **OPERATION MANUAL** before operating this equipment
- **NOTE:** Sam Dick Industries, Inc. reserves the right to use alternate manufacturers' components as vendor delivery applicability dictates. Literature contained in the Operation Manual has been supplied by vendors. Please check to be sure the supplied data matches your configuration. Contact Sam Dick Industries if any questions exist.
- This equipment uses **LPG**, a flammable fuel handled under pressure. Inherent hazards exist and a thorough understanding of the equipment is required to allow safe operation and maintenance.
- Allow only a **TRAINED and FULLY QUALIFIED PERSON** to service this equipment.
- Any time a component must be replaced, use the same type, model, etc. **DO NOT SUBSTITUTE!** The consequences from such actions are unpredictable and may lead to dire consequences. When components are replaced with components not approved for use in our **FM/CSA** listed equipment, the **FM/CSA** listing becomes void for that unit.

**WARRANTY REGISTRATION**

**Roger Duquette**  
**Customer Service Department**

Type of Equipment: \_\_\_\_\_ Serial Number: \_\_\_\_\_

SDI Sales Order #: \_\_\_\_\_ Order Date: \_\_\_\_\_

Purchased By: \_\_\_\_\_  
\_\_\_\_\_  
\_\_\_\_\_

To help us give you better service, please fill out this warranty registration form and return it to us so we can register your purchase and follow up on the performance of our equipment. We are dedicated to producing a quality product and if you have a problem, we want to know about it. Please help us with a small amount of information about your company and about how you are using the equipment. If you need to call us, please have the type of equipment and the serial number handy so we can give you accurate information. If you have had any kind of problem with this equipment up to now, or you have any comments, please attach a separate sheet to this form to tell me about it. Keep a copy of this for your records.

End Customer/Company Name: \_\_\_\_\_

Address: \_\_\_\_\_ Tel: \_\_\_\_\_

City: \_\_\_\_\_ State: \_\_\_\_\_ Zip: \_\_\_\_\_ Fax: \_\_\_\_\_

Name of individual to contact for follow up information: \_\_\_\_\_

Title: \_\_\_\_\_

Usage - Circle one:      Base Load      Standby System  
                                 Peak Shaving      Other: \_\_\_\_\_

In what industry is the equipment being used? \_\_\_\_\_ SIC Code: \_\_\_\_\_

When was the equipment put in service? \_\_\_\_\_ / \_\_\_\_\_ / \_\_\_\_\_

Note: If you have more than one piece of our equipment, fill out one warranty sheet and staple the others to it. We'll do the rest.

How can we better meet your needs?

\_\_\_\_\_  
\_\_\_\_\_  
\_\_\_\_\_

---

-----  
-----  
-----  
-----

Place  
Postage  
Here

 **Sam Dick Industries**

*....a subsidiary of Eclipse, Inc.*

**Attn: Customer Service Department  
P.O. Box 70498  
Seattle WA 98107**

---

## NOTICE

*Sam Dick Industries, Inc. (SDI)*, shall not be liable for technical or editorial errors in this manual or omissions from this manual. **SDI** makes no warranties, express or implied, including the implied warranties of merchantability and fitness for a particular purpose with respect to this manual, and in no event shall **SDI** be liable for any special or consequential damages including, but not limited to, loss of production, loss of profits, etc.

Product names used herein are for manufacturer or supplier identification only and may be trademarks/registered trademarks of these companies.

Copyright © 1994  
by **Sam Dick Industries, Inc.**  
Seattle WA 98107

All rights reserved. No part of this manual may be reproduced or copied in any form or by any means - graphic, electronic, or mechanical - without the prior express written consent from **Sam Dick Industries, Inc.**, Seattle WA USA

# TABLE OF CONTENTS

<u>TOPIC</u>	<u>PAGE NUMBER</u>
Introduction . . . . .	1
A. Special Problems . . . . .	1
B. Sam Dick Industries Pumping systems . . . . .	1
Figure . . . . .	2
I. Description . . . . .	3
A. Pumps BS1 through BS1 1/2 . . . . .	3
Figure 2 . . . . .	4
B. Pumps BS2 through BS3 . . . . .	5
II. Basic Components . . . . .	6
A. Valves . . . . .	6
B. Inlet Strainer . . . . .	6
C. Pump - Sliding Vane Description . . . . .	6
D. Electric Motor . . . . .	7
E. Start/Stop Switch . . . . .	7
F. Three Position Switch . . . . .	7
G. By-Pass Flow Option . . . . .	7
II. Installation . . . . .	8
Figure 3 . . . . .	8
A. General Installation . . . . .	9
B. Pump Base . . . . .	9
C. Types of Valves and Fittings to Use . . . . .	9
D. Pump Location and Piping . . . . .	9
E. Determining Correct Pump Capacity . . . . .	10
F. Pump Motors . . . . .	10
G. V-Belt Drive Pumps . . . . .	11
Figure 4 . . . . .	11
Figure 5 . . . . .	12
H. Direct Coupled Pumps . . . . .	12
Alignment Guidelines . . . . .	13
Figure 6 . . . . .	13
Figure 7 . . . . .	13
Figure 8 . . . . .	13

# TABLE OF CONTENTS

<u>TOPIC</u>	<u>PAGE NUMBER</u>
IV Initial Startup . . . . .	15
Pump Setting and Adjustment Procedures . . . . .	15
A. Adjusting Output Setpoint . . . . .	16
B. Internal Pump Relief Valve Adjustment . . . . .	16
V Operation . . . . .	17
A. Startup . . . . .	17
B. Normal Operation . . . . .	17
VI Maintenance . . . . .	19
A. Strainer . . . . .	19
B. Lubrication . . . . .	19
C. Pump Overhaul and Repair . . . . .	19
Tools Required . . . . .	20
Disassembly . . . . .	20
Assembly . . . . .	20
VII Pump Troubleshooting Guide . . . . .	23
VIII Pump Maintenance Schedule . . . . .	26
Appendix A - Electrical Drawings	
Appendix B - Parts Information	
Appendix C - Recommended Spare Parts	

# STABILAIRE®

## Liquid LPG Pump Packages

### INTRODUCTION

#### A. SPECIAL PROBLEMS OF PUMPING LIQUID PETROLEUM GAS

Pump Systems manufactured by Sam Dick industries are designed to pump Liquid Petroleum Gas, both butane and propane, in their compressed liquid state. Because propane and butane are pumped in an unnatural state, they are difficult to handle. The slightest drop in pressure or the smallest addition of heat will cause the LPG to boil, especially when it is going through a pipe. LPG is extremely flammable so movement through pump systems is hazardous. All necessary safety measures with LPG pump systems should be taken.

#### B. SAM DICK INDUSTRIES PUMPING SYSTEMS

Sam Dick Industries STABILAIRE Liquid Pump Systems are fully packaged pumping systems designed to pump liquid petroleum gas in its liquid state. The systems are pressure stabilized and include a positive displacement sliding vane pump with an internal relief valve, explosion proof motor, bypass line, pressure relief valve, shut-off valves, check valves and pressure gauges. The pressure relief valve provides a stable delivery pressure by returning excess pump capacity to the storage tank. The STABILAIRE systems are designed for continuous use and meet all Class I, Division I, Group D requirements. All of the electrical wiring is in explosion proof conduit. An inlet strainer is provided for field installation. Each system is leak tested at the factory.

The smaller capacity pump systems, models BS1 through BS 1½ are direct drive units, the pumps are either mounted directly on the face of the motor by flange or are connected to electric motors by a flexible coupling. The larger capacity pump systems, models BS2 through BS3, are driven by "V drive" belts. The smaller pump systems, BS1, provide 10 to 15 gpm (38 to 57 lpm) at a differential pressure of 125 psi (862 kPa). The BS1½ have capacities from 9 to 35 gpm (34 to 132 lpm) at a differential pressure of 150 psi. Models BS2 and BS3 provide from 30 to 300 gpm (114 to 1135 lpm) at a differential pressure of 150 psi. The pumps used in the larger systems have a special cavitation liner that "cushions" the effects of collapsing vapor bubbles within the pump, reducing noise, vibration and wear.

The pumps themselves are designed for easy maintenance and feature replaceable end disks, vanes, casing liners and seals which can be easily replaced with basic tools. The sliding vanes are self-adjusting and maintain their efficiency throughout their life.

Both direct coupled and belt driven pumps have heavy duty bolted-down safety covers surrounding their drives. All systems are supplied with industrial duty explosion proof motors.

The pump systems feature a manual starter located near the motor. Magnetic starters featuring a Hand-Off-Auto switch are available as an option for the systems. Another option includes a pressure switch system and magnetic starter to turn on the pump when the LPG storage tank pressure is below a pre-set level.

COMPONENT DRAWING - BS1 AND BS-1 1/2

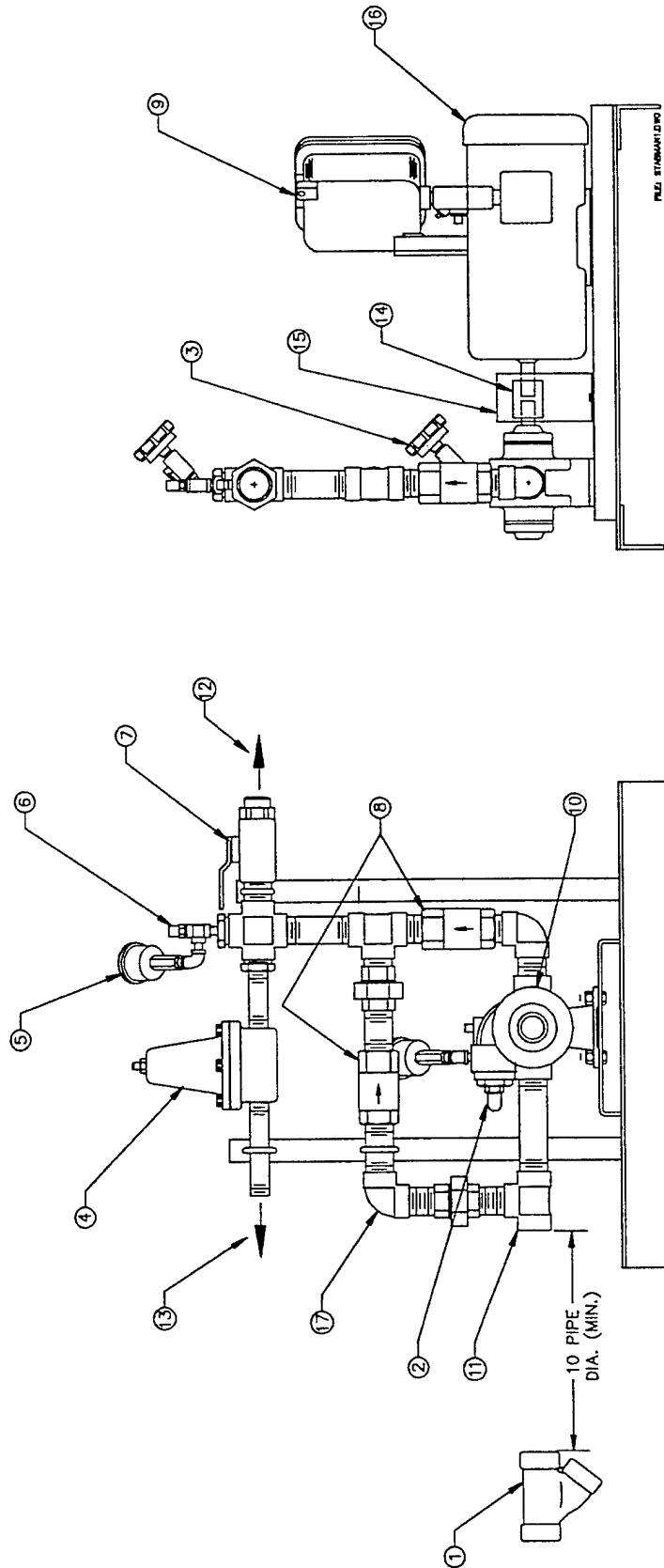

FIGURE 1

Table 2-1

## **I. DESCRIPTIONS OF SAM DICK INDUSTRIES PUMPING SYSTEMS**

**NOTE:** These systems are designed for above ground LPG tanks. A special pumping system is required for use with underground tanks.

### **A. SMALLER PUMP SYSTEM - MODELS BS1 THROUGH BS 1 1/2**

The following are the major components of pump systems BS1 through BS1 1/2. The systems come assembled as a unit. See Figure 1.

1. LPG Inlet Strainer
2. Internal Relief/By-pass valve
3. LPG Inlet Pressure Gauge
4. Back Pressure Control Valve
5. LPG Outlet Pressure Gauge
6. Hydrostatic Relief Valve
7. Outlet Isolation Valve
8. Check Valves
9. Starter or On-off control switch
10. Pump - positive displacement sliding vane type
11. LPG Inlet
12. LPG Outlet
13. LPG Excess Return
14. Coupling Guard
15. Coupling Between Motor and Pump
16. Explosion Proof Electric Motor
17. LPG Bypass

# COMPONENT DRAWING - BS-2 AND BS-3

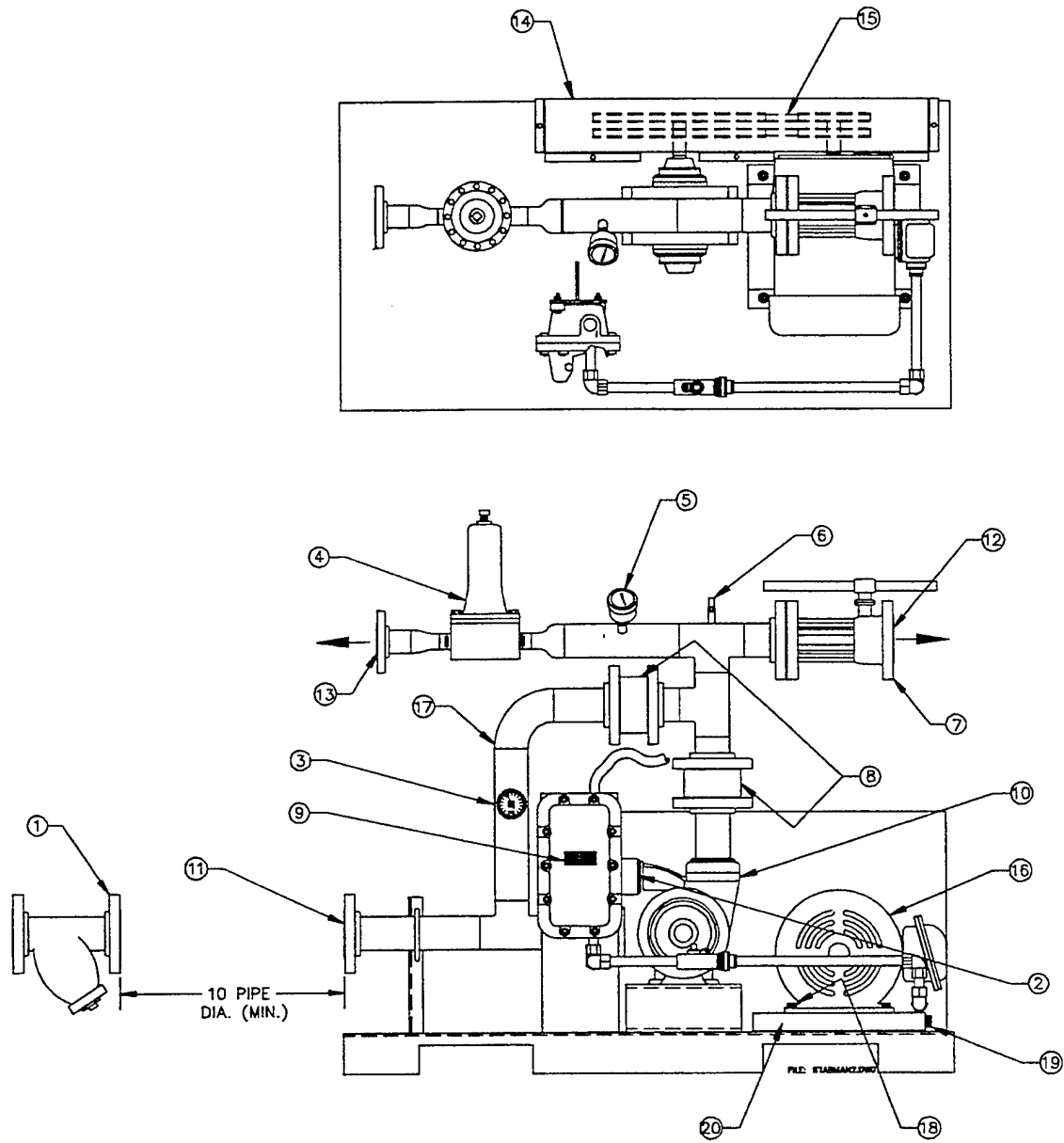

FIGURE 2

## **B. LARGER PUMP SYSTEMS - MODELS BS2 THROUGH BS3.**

The systems come assembled as a unit. See Figure 2.

1. LPG Inlet Strainer
2. Internal Relief/By-pass valve
3. LPG Inlet Pressure Gauge
4. Back Pressure Control Valve
5. LPG Outlet Pressure Gauge
6. Hydrostatic Relief Valve
7. Outlet Isolation Valve
8. Check Valves
9. Starter with On-off control switch
10. Pump - positive displacement sliding vane type
11. LPG Inlet
12. LPG Outlet
13. LPG Excess Return
14. V-Belt Guard
15. V-Belt Drive
16. Explosion Proof Electric Motor
17. LPG Bypass
18. Motor Mounting Bolts
19. Motor Position Adjustment Screw

## II. BASIC COMPONENTS OF STABILAIR PUMP SYSTEMS

### A. VALVES

#### **Back Pressure Control Valve**

This valve adjusts downstream discharge pressure. When discharge pressure exceeds the relief valve setpoint, the LPG returns to the storage tank.

#### **Internal Relief/By-pass valve**

This valve is set at the factory to relieve excessive differential pressure if the back pressure control valve malfunctions.

#### **Hydrostatic Relief Valve**

The hydrostatic relieve valve protects the pipe from trapped LPG liquid. If liquid is trapped and builds up pressure higher than the factory setting it automatically discharges. It automatically reseats after discharge.

#### **Isolation Valve**

Isolation valves allow the gauges to be removed without shutting down the system and can also be used to bleed the system by removing the gauge first. Isolation valves also allow air to be bled out of the system when it is first installed.

#### **Outlet Isolation Valve**

The Outlet Isolation valve is used to close the pump discharge when setting the back pressure control valve and also to facilitate pump repair and maintenance.

#### **Check Valves**

Check valves prevent the LPG liquid from flowing backward to the pump while allowing a bypass for the LPG when the pump is not used.

### B. INLET STRAINER

Traps dirt and foreign material in the system.

### C. PUMP - POSITIVE DISPLACEMENT SLIDING VANE TYPE

For maximum efficiency the pumps use a rotor with sliding vanes. The LPG is drawn behind each vane through the inlet port and into the pumping chamber. As the rotor turns, the LPG is transferred between the vanes to the outlet port where it is discharged as the pumping chamber narrows. Each vane pushes the LPG before it.

The pump vanes maintain contact with the chamber by three forces: (1) centrifugal force from the rotor's rotation, (2) push rods moving between opposing vanes, and (3), liquid pressure entering through the vane groves and acting on the rear of the vanes.

Pump efficiency is maintained as the vanes wear out. New vanes and the pump vane liner can be replaced quickly and easily without removing the pump from the system.

Rotation of the pump is always counter-clockwise when viewing the unit from the pump end. Standard assembly is with the intake to the left and discharge to the right.

#### **D. EXPLOSION PROOF ELECTRIC MOTOR**

The motors are sealed and the bearings do not require lubrication or maintenance of any kind.

The motors are designed for 20% overload for short periods of time. The pump motors have an overload protector and will shut off if they become overheated. Low voltage at the motor will also cause the motor to shut off.

**NOTE:** Explosion Proof Electric Motors are subject to moisture condensation inside when not used regularly. Moisture inside the motors can cause electrical problems and may short out the motor. To eliminate this problem, operate the motor at least once a week long enough for it to get hot.

#### **E. START/STOP SWITCH**

The start/stop switch is either manual or magnetic. Pumps with magnetic control systems can be operated remotely, by a computer control system or by hand. If pumps with magnetic switches are overloaded, the pump will automatically shut off.

#### **F. THREE POSITION SWITCH**

Pumping systems supplied with the optional magnetic starter use a 3 position switch known as a "Hand-Off-Auto" switch.

The **HAND** Position allows the pump to be started manually. The **OFF** position will stop the unit under any condition. The **AUTO** Position allows the unit to be operated from a remote control source.

#### **G. BY-PASS FLOW OPTION - ECONOMY SETTING**

The optional by-pass feature of STABILAIRES Pump Systems saves energy by shutting off the pump automatically and letting incoming LPG by-pass it if the tank and inlet pressure are adequate. Sam Dick Industries terms this "Economy Setting."

# TYPICAL INSTALLATION DRAWING

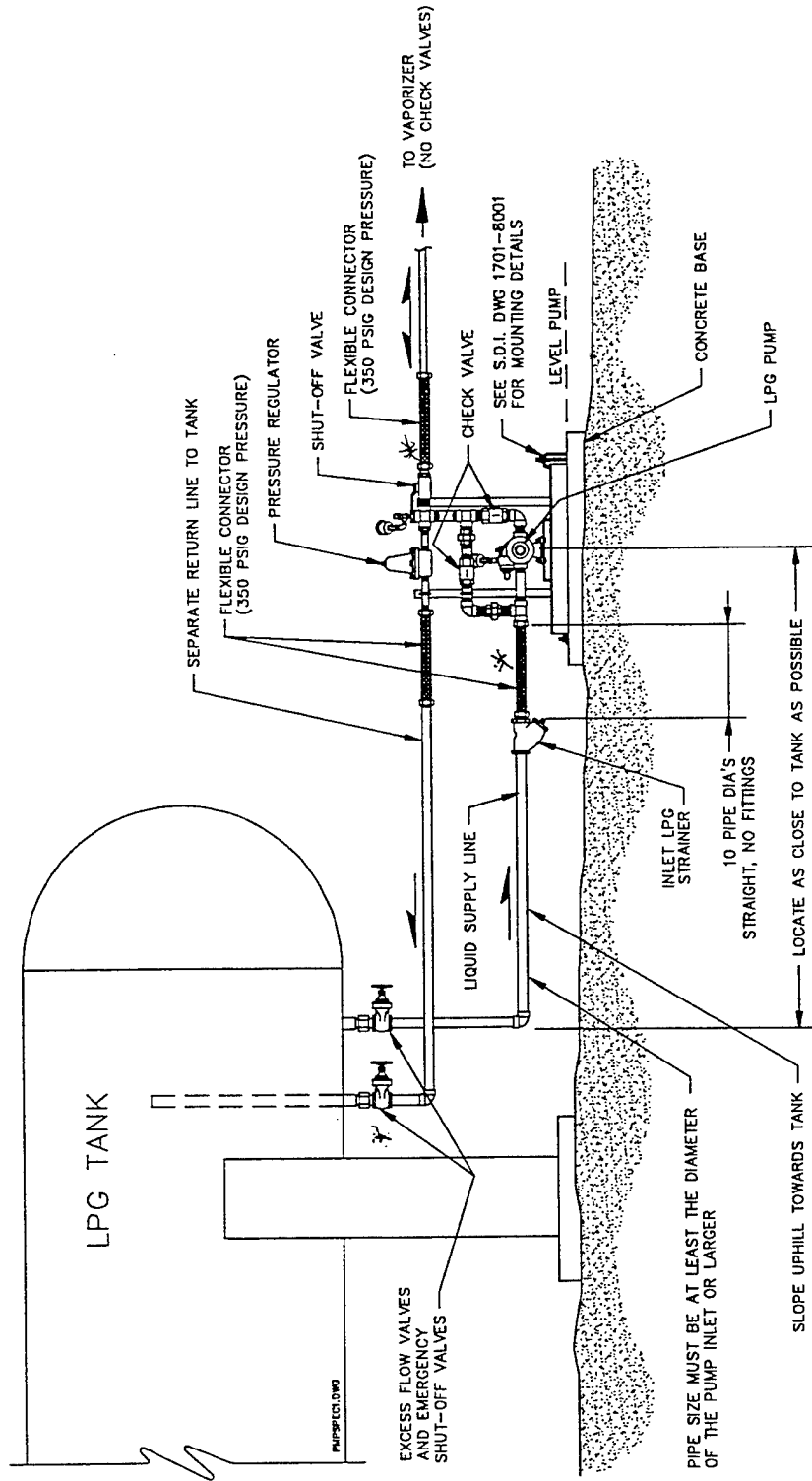

NOTES:  
 INSTALLATION MUST MEET NFPA58 AND 70 OR  
 OTHER APPLICABLE CODES.

FIGURE 3

## II. INSTALLATION

### A. GENERAL INSTALLATION OF STABILAIRE PUMP SYSTEMS (See Figure 3)

All local codes and regulations must be determined so the installation conforms to local requirements.



**CAUTION:** LPG is explosive and extremely flammable. Appropriate safety procedures must be observed when installing and operating the system.

### B. PUMP BASE

The steel base of the pump unit must be installed on concrete. Pumps bolted to a concrete foundation will operate better with less vibration. The steel base must be level on the concrete. If necessary, drive metal shims under the steel base near the concrete anchor bolts to make the base level. Refer to drawing # 1701 for mounting suggestions.

### C. TYPES OF VALVES AND FITTINGS TO USE

Use gate or ball type valves, not globe valves for installation. The flow of the LPG should be as straight through as possible. See figure 3.

Do not use fittings that reduce the LPG pressure. Vaporization may occur and cause cavitation.

### D. LOCATION AND PIPING - GENERAL INFORMATION

If the LPG liquid boils in the intake line the system may fail. Boiling may be caused by heat from sunshine, heat from the earth on underground piping, heat from the atmosphere when the air is warmer than the liquid in the pipes, friction from the liquid in the pipe and restrictions in the pipe. Vapor in the pipe may reduce the flow of LPG liquid to the pump, causing a shut-down.

Locate the pump within five feet (1.5 meters) of the LPG storage tanks to reduce the friction of the LPG through the pipe.

Whenever possible, locate the pump directly under the supply tank so the piping will be short to keep friction loss minimal and where vapors will rise into the tank.

Never locate the pump more than 50 piping feet (15 meters) from the LPG tanks.

Where the pipes are connected horizontally to the pump, slope the piping downward to the pump at least one inch per 10 feet (2.5 centimeters per 3 meters) so vapors will go back to the tanks. Whenever possible, the pipe should drop straight down from the manifold at least 12 inches (30 centimeters) to the pump.

The inlet pipe should ~~be~~ have a length ten times that of its diameter between the pump inlet and strainer.

Do not bury the intake lines underground. Do not route the intake piping upward at any point because vapor will accumulate. In cold weather when vaporizers are needed most, pump cavitation from vapors is much worse because bubbles from boiling are much larger because vapor pressure is low.

Flexible connectors are recommended for the intake and discharge piping because they will result in much quieter pump operation and help eliminate vaporization problems. The recommended flexible connectors should be rated at least 350 psi (24.5 KG/CM<sup>2</sup>) see NFPA 58.

When installing the system, check to make sure that the pipes are properly supported so there is no pipe strain on the pump. Always flush the piping before installing the pump to remove all debris and welding slag.

#### **E. DETERMINING CORRECT PUMP CAPACITY**

The delivery rate of LPG at the system operating pressure should be 2 to 3 times the maximum system consumption. For example; a 1,000 GPH system requires a pump with a capacity of 2,000 to 3,000 GPH at the desired pressure.

All vaporizers have a cycling type of operation and have changes in load during operation. In the cycling process the flow rate of LPG liquid from the pump to the vaporizer is much larger than a calculated steady flow rate. For example, in the case of a vaporizer supplying LPG vapor to a blender that has only one venturi, the off period is zero flow and the on period is maximum flow.

When the system starts and the vaporizer begins operating, the liquid chamber is empty of LPG and must be filled rapidly to avoid a low pressure condition. This requires extra pump capacity.

Maximum flow rates are always used in determining the sizing of propane equipment. The piping from the pump to the vaporizer should be sized for the maximum capacity of the vaporizer. In determining the pump capacity, the pressure drop through the vaporizer control system and the vapor regulator must also be considered. The pump output pressure must be determined by calculating the total pressure drop in the system.

The built-in relief valve on the pump is factory set to prevent recirculation which would cause vapor binding. Never connect the discharge pipe into the pump intake piping.

#### **F. PUMP MOTORS**

The lead wires to the motor starter should be run through rigid metal conduit with threaded, explosion-proof joints and explosion proof condulets. Adequate size wire must be used from the power source to the motor starter.

Motor rotation should always be the same as the direction arrow on the pump body. If the motor rotation is incorrect, check the wiring with the wiring diagram on the motor.

**NOTE:** 3 phase motors may be reversed in direction by changing the position of any two of the three lead wires.



**CAUTION:** Do not reverse the pump rotation to reverse the direction of the flow. This will not work! Reverse rotation would make the pump unsafe and work poorly.

An overload protector will cut off power to the motor if it overheats. The motor temperature depends on the load and the air temperature. Shading the motor from direct sunlight will help reduce its operating temperature.

### G. V-BELT DRIVE PUMPS (Refer to Figure 2)

Loose belts will cause noise and excessive wear. Follow these directions for installation or replacement of V-belts.

#### V-Belt Installation Guidelines

- 1) Remove V-Belt guard, # 14, unscrew the bolts holding it down and lift it up and out of the way.
- 2) Check for proper rotation, by applying power to motor. Check pump rotation direction indicated on pump, motor rotation **MUST** match that of pump.
- 3) After proper rotation has been verified, disconnect power to motor.
- 4) Loosen, but do not remove, the four motor mounting bolts, # 18.
- 5) Loosen motor position adjustment bolt(s) #19 until approximately 1" to 1 1/2" of the motor position adjustment bolt(s) are visible. This will allow the motor to be moved towards the pump for easier installation of the V-Belt(s) onto pulleys.
- 6) Install V-Belt(s) over both pulleys.
- 7) Check for proper alignment of pulleys with a straight edge. Place the straight edge against the outside face of both pulleys. The straight edge **MUST** be able to lay up against both edges of both pulleys, at the same time. The pulleys are aligned when the straight edge is flush at points A through D. See figure #4.

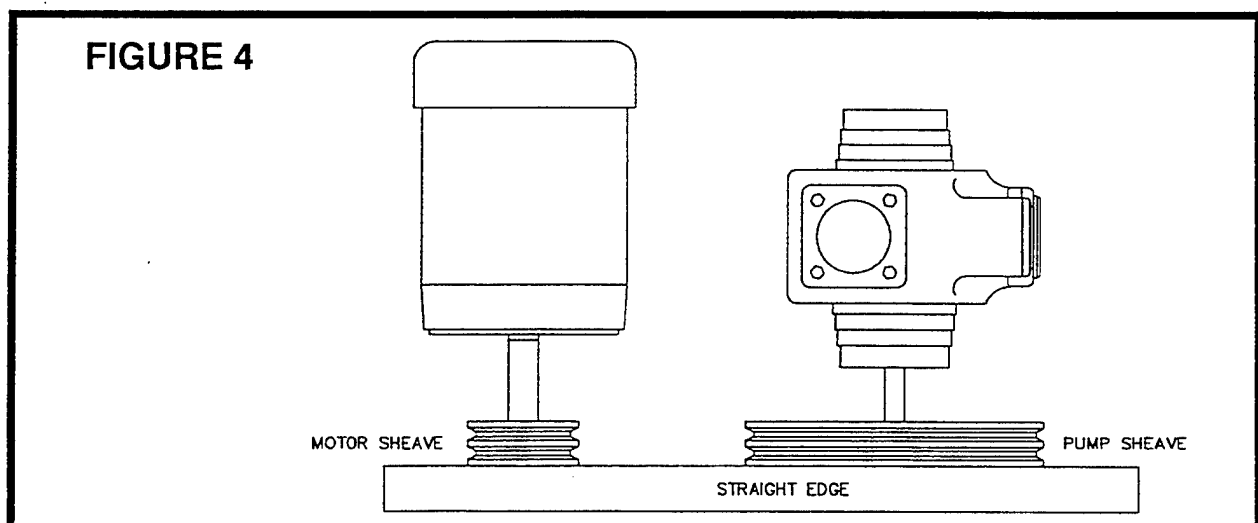

- 8) Tighten motor position adjustment bolt(s) evenly until proper belt tension is achieved. Proper belt tension is the lowest tension at which the belt(s) will not slip under peak load conditions. A general rule for S.D.I.'s application of V-Belts: A 10 to 15 (4 to 7 KG.) pound pressure applied at the center point on the belt between the pump and motor pulleys should deflect the belt  $1/2"$  to  $3/4"$  (1 cm to 2 cm), Figure 5.

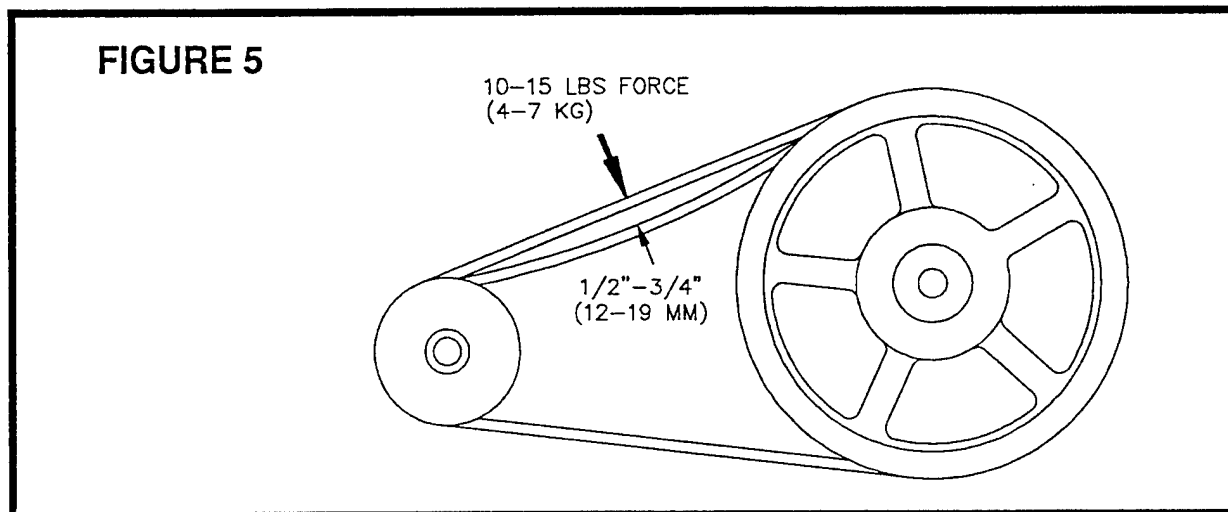

- 9) After proper tension has been achieved, re-check for proper pulley alignment with a straight edge. Place the straight edge against the outside face of both pulleys. The straight edge **MUST** be able to lay up against both edges of both pulleys, at the same time. The pulleys are aligned when the straight edge is flush at points A through D. See figure 4. If belt tension adjustment has misaligned the pulleys, the motor adjustment bolts must be loosened and the procedure repeated.
- 10) Tighten the four (4) motor mounting bolts (item 18) securely.
- 11) Before replacing the V-Belt guard (14), momentarily apply power to motor to double check tension, alignment and rotation.
- 12) Replace the V-Belt guard and tighten all bolts securely.

#### H. DIRECT COUPLED PUMPS (Refer to Figure 1)

The coupling alignment must be near perfect to give quiet, long-life service to the Pump and Driver. The pump and Driver shafts are carefully aligned at the Factory, but the alignment should always be checked after the pump is installed and before initial operation.

After the power to the pump motor is disconnected and the coupling guard is removed, use either of the methods described on the following pages to align the pump coupling.

## Alignment Verification Guidelines for Direct Coupled Pumps

- 1) Disconnect power to pump motor.
- 2) Remove coupling guard.
- 3) Inspect flexible coupling insert for wear.
- 4) Two (2) methods can be used to check alignment of couplings. One requires the use of a small straight edge. The other requires the use of a feeler gauge.

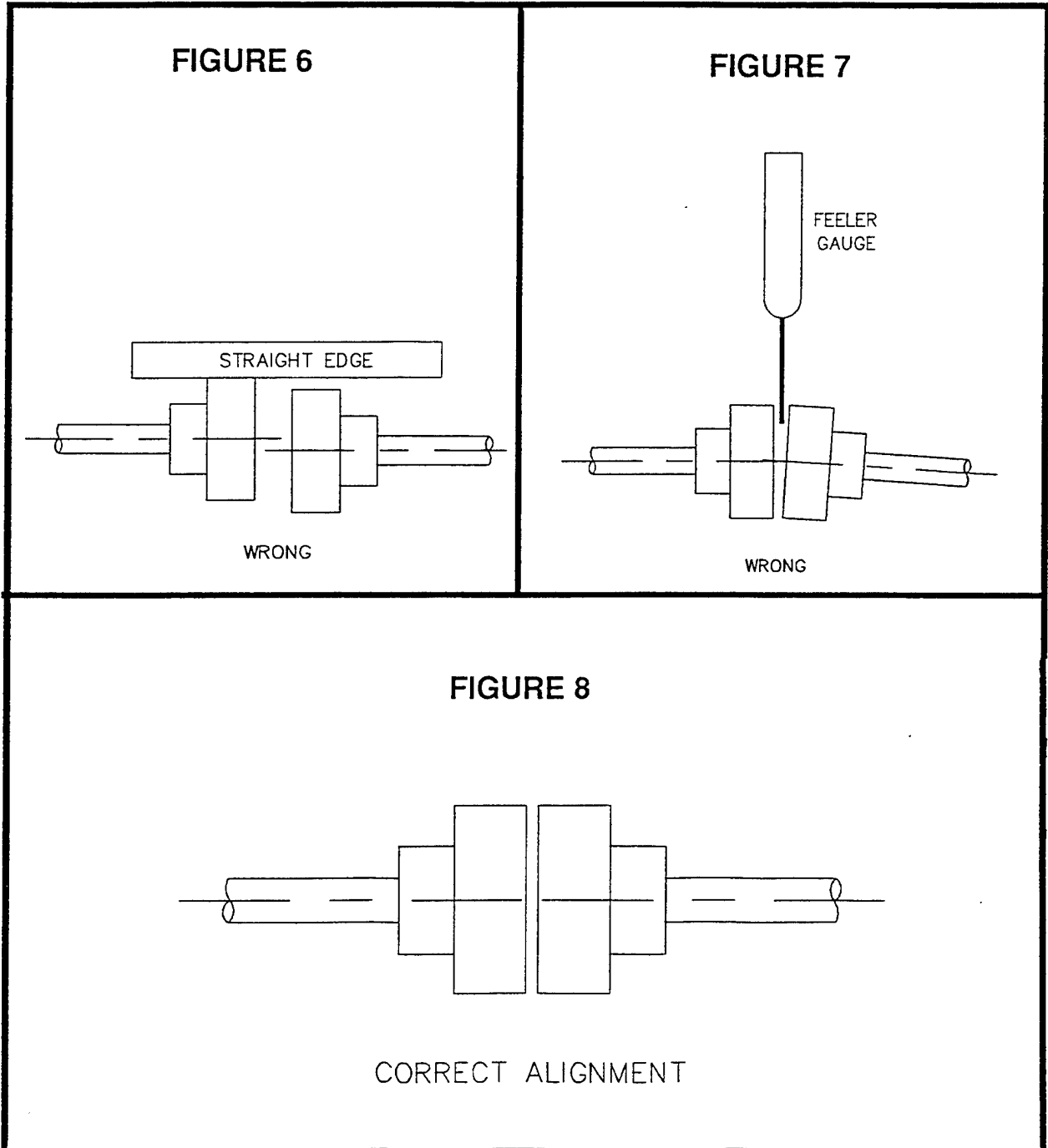

**A) STRAIGHT EDGE METHOD (See Figure 6)**

Place straight edge on to of both couplings, making sure to span entire coupling assembly. Both couplings must be flush with the straight edge. **WITHOUT** turning the coupling, move the straight edge 90° to the next test point, continue to check coupling alignment in 90° increments. All four test points **MUST** be flush with the straight edge. If couplings are out of alignment, premature wear of the flexible coupling insert will occur.

**B) FEELER GAUGE METHOD (See Figure 7)**

Find proper thickness feeler gauge blade(s) that will fit between coupling halves at point A, without turning the coupling. Insert feeler gauge at point B. Continue until all test points have been tested. If pump and motor are aligned properly, the feeler gauge will fit the test points with the same clearance.

If the clearance changes from test point to test point, re-alignment will be required, to prevent premature wear of the flexible coupling insert.

Lateral misalignment will require loosening of motor mounting bolts, repositioning of the motor, testing for proper alignment and tightening of the motor mounting bolts.

Vertical misalignment will require loosening or removing motor mounting bolts and by the use of shimming material, reposition motor for proper alignment, test for proper alignment. Finally, tighten motor mounting bolts.

- 5) If the flexible coupling is worn it must be replaced
- 6) To replace a worn coupling, perform the following:
  - a) Remove the motor
  - b) Remove the old coupling
  - c) Install a new coupling
  - d) Re-install the motor
  - e) Align the motor and the pump by the methods described above.

## **IV INITIAL STARTUP**

### **A. OPERATION CHECK**

Thoroughly check the entire LPG facility for safe operation and function before starting up the process. The check must include the condition and operation of the storage tanks, pipes, electrical wiring, and appropriate valves all the way to the outlet and transfer pipes.

### **B. TAKE ALL SAFETY PRECAUTIONS!**



**CAUTION:** LPG is explosive and extremely dangerous. Take all necessary safety precautions in operation of the system. No open flames or sources of electrical sparks should be in the operating facility.

**NOTE:** All piping of the system, both incoming and outgoing, should be thoroughly cleaned and tested before starting.



**WARNING:** No smoking throughout the entire facility! Even smoking in an adjacent room next to the facility or outdoors close by is dangerous.

### **C. VERIFY THAT THE PUMP SYSTEM HAS BEEN INSTALLED CORRECTLY.**

1. Check the pump system for correct installation of all components. All bolts should be tight, fittings secure and the V belts should be correctly adjusted. See the maintenance section for correct tightening of belts if necessary.
2. Check the wiring, make sure there are no broken or frayed wires and that all wiring is properly installed. Check all electrical conduit for correct installation and ensure that all fittings are tight.
3. Measure the incoming current with a voltmeter to check if it is the correct current for the system.
4. All piping should be clean, free of moisture and have no leaks. Even a small leak anywhere in the entire facility is unacceptable!

### **D. PUMP SETTING AND ADJUSTMENT PROCEDURES (Refer to Figures 1 or 2)**

Perform these procedures on initial startup of the system, if the pump is restarted after being idle, or if the delivery pressure or tank pressure changes.



**CAUTION:** Before performing this procedure follow all safety procedures for LPG make sure there are no open flames or electrical sparks, wear gloves and appropriate clothing.

## A. ADJUSTING OUTPUT SETPOINT

- 1) Determine the required pump discharge pressure.
- 2) Slowly open shut-off valves in the storage tank for pump suction line and return lines. Open all shut-off valves between storage tank and pump.
- 3) Verify tank pressure reading and gauge reading on LPG pump inlet. Both should correspond with each other. If not, refer to step #2.
- 4) Close shut-off valve at pump outlet.
- 5) Loosen locknut on adjustment bolt for the control valve, item # 4. Turn adjustment bolt out until it is loose. **DO NOT** remove completely.
- 6) Turn pump on, you may notice a slight pressure increase at the outlet pressure gauge.
- 7) Slowly start to turn adjustment bolt "in", on the control relief valve, Item #4, until the desired outlet pressure is attained. Stop the adjustment when the pressure is obtained.
- 8) Tighten locknut, making sure adjustment bolt does not turn while tightening.

## B. INTERNAL PUMP RELIEF VALVE ADJUSTMENT



**CAUTION:** Only try this test briefly. If the relief valve doesn't open during the test, open the outlet valve. The internal bypass valve of the pump is designed for emergency protection only. It may be damaged if this procedure is done for any length of time.

- 1) To test internal pump bypass valve (item #2) for proper operation, with pump outlet closed and pump on, momentarily close manual shut-off valve in the control relief valve return line to the tank. The differential pressure increase should be between 150 psi and 170 psi over the inlet pressure (the factory setting of the internal bypass valve of the pump).

For example: if the inlet pressure is 40 psi, the outlet pressure should be 190 to 210 psig.

Differential pressure is the difference between pump inlet and outlet pressure, or the amount of pressure the pump adds to the LPG coming into it.

- 2) The internal bypass valve is factory set. Under normal operation the valve should not need to be adjusted. However, if the valve opens above 170 psig or below 120 psig then it should be adjusted.
- 3) Open manual shut-off valve in the control relief valve return line to the tank.
- 4) Open pump outlet shut-off valve (Item #7), pump is now ready for operation.

## V OPERATION



**CAUTION:** LPG is explosive and extremely flammable. Appropriate safety procedures must be observed when installing, starting, and operating the system.



**WARNING:** Any leak anywhere in the system is extremely dangerous and should not be tolerated. If any leak is detected the entire system must be shut down, power turned off, lines bled to zero and the leak must be stopped and properly repaired.

### A. START UP

1. Check the system thoroughly before putting it into operation. Any problem with the system: leak, faulty valve, lose belt, lose bolt or connection is unacceptable! Repairs must be made immediately.

The wiring should be examined for correct connections, voltage and proper rotation.

2. Open all valves in the lines to the pump.
3. Turn on the power to the pump
4. Turn on the pump.

If it is in correct operating order, the motor should start quickly, the pressure will come up immediately, the pump will run at normal operating speed and the pressure gauge on the discharge side of the pump will indicate the correct operating pressure. Refer to trouble shooting guides if there is pump noise, vibration, leakage, overheating, or low pressure.

To check pump operation separately, start it manually. (In systems with magnetic starters, put the **Hand-Off-Auto** Switch in the **HAND** position).

### B. NORMAL OPERATION

1. Operating Precautions

Do not run the pump dry. This will damage the pump.

Do not allow LPG liquid to cavitate in the pump as this will also damage it.

Correct piping minimizes vaporization of the LPG liquid into the pump. Excessive vaporization in the intake line causes pump noise and excessive wear. Restrictive intake piping, globe valves, or some types of tank outlet valves can cause cavitation. Circulation of LPG liquid through the built-in relief valve causes cavitation inside the pump. The relief valve is an emergency protection device only.

Check the inlet and outlet pressure at regular intervals.

Check the bearing seal at the side of the pump for leaks.

Pump drives should operate satisfactorily with a minimum of vibration.

If direct coupled pumps vibrate excessively they should be checked for alignment as noted in the maintenance section.

After the initial installation of V-Belts, the tension and alignment must be checked after the first eight (8) hours of operation (BS2 and BS3 only).

2. Inlet pressure

If the inlet pressure differs or fluctuates from the setpoint the system should be shut down, lines bled to zero pressure, purged and source of difficulty determined. (Changes in climate and different types of LPG in the storage tank will also cause changes in inlet pressure.)

3. Outlet Pressure

If the outlet pressure and all other parts of the pump system are functioning normally, the control valve must be reset. See "Adjusting the Output Setpoint" procedure in the initial startup section.

5. Back Pressure Relief Valve

The back pressure relief valve may need to be adjusted as climatic conditions change causing a change in the storage tank pressure, or if different kinds of LPG are stored in the tank with different storage pressure ratings.

To adjust the back pressure relief valve perform the following:

- a. Turn off the pump.
- b. Loosen the adjusting nut on the relief valve and screw out the pusher post all of the way.
- c. Start the pump, make sure the pump is operating normally.
- d. Slowly screw in the pusher post until the output pressure is the desired setting.
- e. Tighten the adjusting nut.

**NOTE:** The back pressure relief valve should be set about 5 pounds over the inlet pressure.

## **VI MAINTENANCE**

### **A. STRAINER**

Inspect and clean the strainer periodically. A dirty strainer screen can cause vaporization, cavitation, lower the pump capacity and increase pump wear.

On new installations, inspect the strainer frequently until the initial accumulation of dirt and other material is flushed from the system.

To clean the strainer, shut down the system, remove the cap and remove the screen.

A plugged strainer basket or a very fine strainer may also cause cavitation and noise.



**CAUTION:** System pressure must be zero before the strainer basket can be removed and cleaned.



**CAUTION:** Strainer contents may be flammable. Observe all safety rules in handling flammable material.

### **B. LUBRICATION**

The pump bearings should be lubricated every three (3) months with number 2 lithium-base type of grease. Apply the grease slowly with a grease gun to the grease fittings on each bearing cover until excess grease begins to come from the relief fitting. It is normal for some grease to escape from the tell-tale holes under the bearing covers for a short period after lubrication.

For operation in very low temperatures, lubricate the pump with a low temperature grease.

**NOTE:** If excessive grease leaks from the holes under the bearing covers the mechanical seal may be damaged or liquified gas may be leaking past the seal and gradually washing grease out of the bearing chamber. Remove the bearing head and examine the mechanical seal for wear or damage. If gas is escaping from the tell-tale holes, the entire mechanical seal must be replaced.

### **C. PUMP OVERHAUL AND REPAIR**



**CAUTION:** Before performing any work on the pump, follow all safety procedures for LPG gas, make sure there are no open flames or electrical sparks, wear appropriate clothing.



**CAUTION:** Do not open the pump until the pressure is bled off. On systems with meters, the differential valve will keep LPG under pressure in the pump, meter and piping even when the hose is emptied.

## Tools Required:

Worn or defective parts can be replaced using the following tools:

- a. Small blade screw driver.
- b. Small hammer
- c. Two pair of Vise-Grip pliers
- d. Long handle wrenches
- e. One-half of the drive coupling and Key

## Disassembly

Lock nuts are secured by a lockwasher tang. This tang must be pried out of one slot, in the lock nut, with a small blade screwdriver. After removing both lock nuts and lockwashers, remove the four (4) head capscrews. While holding the cylinder, tap the drive end of the rotor shaft and the pump will pop apart. Use caution to avoid getting dirt into the bearing grease and to not damage the mechanical seals. Remove the combination bypass and relief valve.

Observe all parts and check them for wear and physical damage. Replace all defective parts. A groove around the cylinder bore or back wall makes that part unusable. These same conditions apply to the head wall. Parts with such grooves should be replaced.

## Assembly

**NOTE:** The rotor and shaft is used as an assembly pilot guide to get alignment between the cylinder and the head.

1. Apply a light coating of grease or oil to the "O" rings and insert the mechanical seal assembly into the cylinder. Insert ball bearing (shield side inboard).
2. Insert the drive end of the rotor shaft through the mechanical seal and bearing. Push the rotor into the cylinder and rotate to engage the seal drive tangs.
3. Install the tang lockwasher and lock nut. Using vise-grip pliers, tighten the lock nut to pull the rotor down tight against the cylinder back wall.
4. Cover the shaft with cloth to protect it, then tighten the drive end of the rotor shaft in a vise. Insert the four (4) vanes.
5. Insert the head "O" ring, mechanical seal assembly, and bearing (shield side inboard) in the head. Place this assembly over the outboard end of the rotor shaft.
6. Press down and rotate the head, to engage the seal drive tangs, then just start the four (4) head capscrews.
7. Install the tanged lockwasher and start the lock nut. Grasp and clamp the lock nut in the vise-grip pliers. With the vise-grip pliers clamped on to the lock nut, pull the head down very tight. Wiggle the head while tightening the lock nut.
8. Tighten the four (4) head capscrews before loosening the outboard lock nut then loosen both lock nuts three (3) or more turns.

9. Using a keyed coupling half, check that the rotor turns free, only the seal should cause any drag. It should turn easily by hand. If the rotor does not run free, tear down the pump and correct the problem.
10. Tighten the drive end lock nut with vise-grip pliers until a moderate rotor drag is felt when turning the rotor shaft with the coupling half.
11. Locate the closet lockwasher tang and lock nut slot. Align that slot and tang and stake the tang into the slot.
12. Clamp the coupling half and the outboard lock nut firmly in vise-grip pliers. Tighten the outboard lock nut approximately one eighth (1/8) of a turn past the point where rotor drag disappears.
13. Remove both vise-grips, turn the rotor shaft with the coupling half and check for free turning (no-metal-to-metal rotor drag). Align the closest slot and tang and stake the tang into the slot.
14. Install the bearing cover and bracket, then lubricate both inboard and outboard bearings.
15. Install the bypass/relief valve making certain the valve slides freely and the disc is properly located in the valve. Insert the valve spring and install the valve cover.

**NOTE:** Vanes installed backwards will cause vibration and low pump pressure.

Improper adjustment of the bearing locknuts will cause worn or scored discs and rotor ends. If the locknuts are not drawn up evenly, the rotor and disc will wear.

## VII PUMP TROUBLESHOOTING GUIDE

PUMP TROUBLESHOOTING		
PROBLEM	CAUSE	SOLUTION
Electric motor will not run	Power is not connected	Connect power
	Blown fuse	Replace fuse
	Switch on starter is not in correct position	Reset switch
	Switch in panel is not in correct position	Reset switch
	Pump switch not reset	To restart pump, first turn off the pump switch, press the reset button, then turn on the pump switch
	Burnt or defective electric motor	Replace motor
	Loose Wires	Reconnect wires
Pump will run - low output pressure	Restricted excess flow valve in tank	Replace excess flow valve <sup>1</sup>
	Restricted valve in inlet pipe line	Open shut-off valves
	Low tank pressure	Check tank pressure
	Worn pump or vanes sticking	Rebuild pump
	Pump speed too low	On pumps with V-belts, check the belt tension
	Low Voltage Supply	Supply correct voltage to motors
	Bypass valve stuck or set too low	Check capacity with bypass line closed with manual valve. Readjust, repair or replace valve.
	Clogged strainer	Clean strainer
	Poor suction	Increase intake and vapor pipe sizes

<b>PUMP TROUBLESHOOTING</b>		
<b>PROBLEM</b>	<b>CAUSE</b>	<b>SOLUTION</b>
Pump will run - high output pressure	Restricted valve in pump return lines	Check all valves
	Relief control valve set too high	Check setting
	High tank pressure	Check tank pressure
	Failed Control Valve	Repair or Replace
Pump runs for short time, then stops	Load too high for motor	Check pump and drive mechanism
	Improper inlet power	Check and restore incoming voltage
	Overload heaters too small	Check overload size
Excessive vibration and/or noise when pump is running	Loose mounting bolts	Tighten all mounting bolts
	Relief control valve line too small	Check data sheet
	Pump and motor out of alignment	Re-align pump and motor
	Worn belts	Check V-Belt Installation Guidelines
	Restricted valve in pump piping	Open all valves in pump piping
	Cavitation from poor suction	Increase size of intake and vapor pipes
	Very high differential pressure	Check for restriction in discharge line
Pump runs but no LPG delivered	Closed valve in line	Open proper valve
	Closed excess flow valve at tank outlet	Open excess flow valve
	Vapor binding or boiling LPG at intake line	Check inlet pipes and valves for proper installation
	Wrong type of valves installed	Install correct valves
	Restriction in suction line	Locate pump as close as possible to supply tank
	Broken pump shaft	Disassemble pump and repair

PUMP TROUBLESHOOTING		
PROBLEM	CAUSE	SOLUTION
Pump leaks	Leakage at drain holes on the bottom of the pump cylinder and the head	Replace mechanical seals
	Leakage between pump cylinder and head	Replace the head "O" ring (head must be removed.)
Pump will not turn	Foreign matter in pump	Clean out the pump - check the strainer and clean it
	Broken pump blades	Disassemble pump and replace blades
	Bearing seized	Clean or replace pump bearings
Unstable Outlet Pressure	Damaged backpressure control valve	Repair or replace backpressure control valve
	Cavitation at pump	Open all valves to pump
		Poor Installation - correct piping to pump
		Clean Strainer
Worn pump	Rebuild pump	

VIII PUMP MAINTENANCE SCHEDULE

DESCRIPTION	ITEM #	FIRST MONTH	EVERY MONTH	EVERY THREE MONTHS	EVERY SIX MONTHS	EVERY YEAR	EVERY 2 YEARS
Strainer					Remove and clean		
Pump Bearings				Grease			
Back Pressure Valve			Adjust				
V-Belts		Check Tension		Visually inspect	Check Tension		Replace
Pump - Vanes, Seals, Shaft						Rebuild and replace all worn parts	

# ***APPENDIX A***

***ELECTRICAL DRAWINGS***

# TYPICAL PROFILE VIEWS OF EQUIPMENT BASE AND MOUNTING

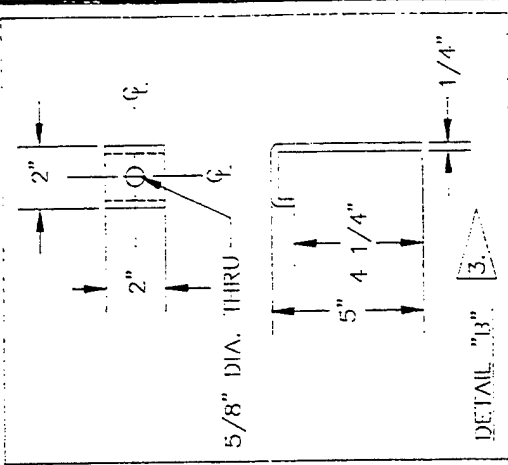
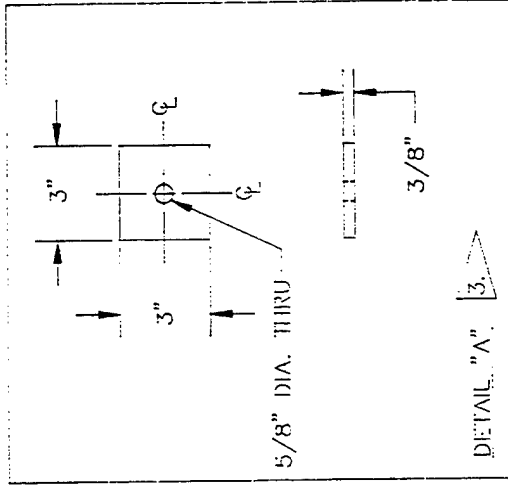
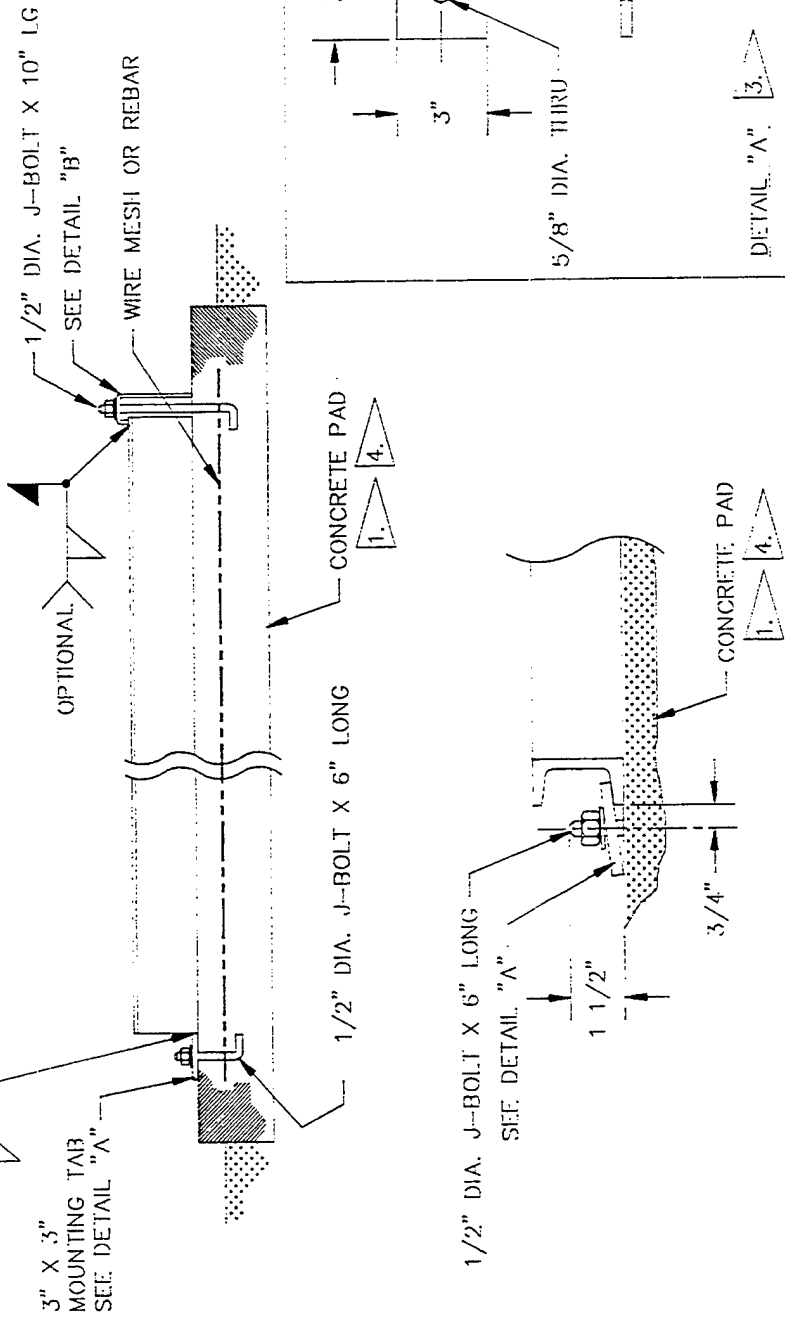

**TOLERANCES UNLESS OTHERWISE SPECIFIED**

.X ±
.XX ±
.XXX ±
ANGLE ± 0°30'
FRACTIONS ± 1/16"
FINISH:

1. USE HIGH EARLY STRENGTH TRANSIT CONCRETE MIX. MIX RATIO TO PROVIDE FOR 2500 PSI MIN. COMPRESSIVE STRENGTH AFTER 7 DAY SET.
2. ANCHOR BOLTS SHOULD BE GRADE 5 (MIN.).
3. MATERIAL: A36 STEEL PLATE OR EQUIVALENT.
4. SIZE AND THICKNESS DEPEND ON THE SIZE AND WEIGHT OF EQUIPMENT TO BE MOUNTED.

**Sam Dick Industries**

1140 N.W. 46th ST. SEATTLE, WA, 98107  
TEL: (206) 789-5410 FAX: (206) 789-5414

Drawn By: BRISSON  
Checked By: 9/8/93  
Scale: 1/4  
Job No. S.D.I. STD.

DATE: 9-8-93

Sam Dick No. Q01801A1.DWG

TYPICAL ANCHORING METHODS

1701-8001

REV. NO. 1 OF 1

REV. BY 9-B-93

APVD

This drawing is the property of SAM DICK INDUSTRIES and is not to be reproduced nor used in any manner detrimental to our interests. All rights are reserved.

***APPENDIX B***

***PARTS INFORMATION***

Section	500
Effective	April 1980
Replaces	November 1976

# BLACKMER LIQUEFIED GAS PUMPS FOR LP-GAS AND NH<sub>3</sub> SERVICE

INSTALLATION, OPERATION AND MAINTENANCE INSTRUCTIONS

**MODELS: LGF1C, LGB1C, LGF1PC, LGB1PC**

## GENERAL INFORMATION

### SAFETY RULES

It is recommended that NFPA Pamphlet No. 58 be consulted for Safety Rules. Consult State and local regulations also.

### WARNING DANGER

**DO NOT ATTEMPT TO OPEN THE PUMP UNTIL YOU HAVE BLED OFF THE PRESSURE. ON SYSTEMS WITH METERS, THE DIFFERENTIAL VALVE WILL KEEP LIQUID UNDER PRESSURE IN THE PUMP, METER AND PIPING EVEN WHEN THE HOSE IS EMPTIED.**

### PUMP DATA

	LGF1	LGF1P
Nominal Capacity (GPM) (1800 RPM - 80 PSI) at Ambient Temperature of:		
80° F.	7	12
32° F.	5.6	9.6
0° F.	4.3	7.4
-20° F.	3.1	5.3
Maximum Differential Pressure (PSI)		
Pump with:		
1 HP - 1800 RPM Motor	80	60*
1½ HP - 1800 RPM Motor	80	90
2 HP - 1800 RPM Motor	80	90

Maximum Pump Speed . . . . . 1800 RPM  
Maximum Temperature (for liquids other than liquefied gas)  
Model LG . . . . . 240° F.

\*Continuous duty of LGF1P at 60 psi employing a 1 HP motor should not exceed 1 hour, due to motor overheating.

These pumps are listed by Underwriters' Laboratories, Inc. for liquefied-petroleum gas and NH<sub>3</sub>, with a vapor pressure of not more than 200 PSI at 100° F., at a differential pressure not over 125 PSI.

### ROTATION

Rotation is always counter-clockwise when viewing the unit from the pump end. Standard assembly is with the intake to the left and discharge to right. See Fig. 1.

Motor rotation should always be the same as the direction arrow on the pump cylinder. If the motor rotation is in-

correct, check the wiring with the wiring diagram on the motor.

Do not reverse the motor rotation to reverse the direction of flow. The pump would be unsafe and operate unsatisfactorily.

### RELIEF VALVE AND BACK-TO-TANK BYPASS VALVE

The built-in spring-loaded valve in these models has a dual purpose. It provides an external bypass back to the tank to provide relief of excess pressure. The valve will also act as a relief valve recirculating within the pump to provide relief of excess pressure, if the separate back-to-tank line is closed.

This valve is pre-set at the factory. The maximum setting for the valve is frequently governed by the horsepower of the motor and should not be increased without checking the pressure and horsepower requirements of the pump and motor.

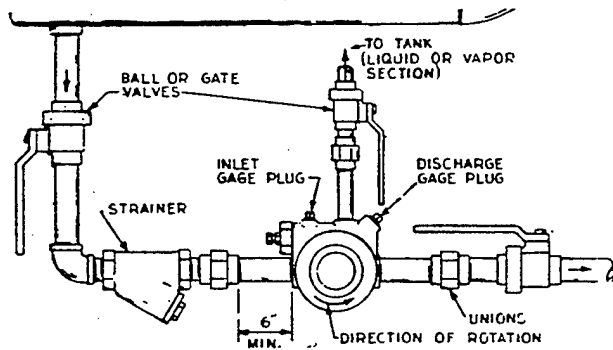

Fig. 1

### LOCATION

Locate the pump as near the source of supply as possible to reduce pipe friction. On liquefied gas the inlet piping and pump should be located below the tank. The head of liquid helps overcome the friction loss in the piping system.

A solid concrete foundation using anchor bolts to mount the unit is recommended to minimize noise and vibration. However, any solid foundation that will secure the unit is satisfactory.

### STRAINER

A strainer should be installed in the intake line to protect the pump from foreign matter. A 1½" size with a 40-mesh screen is recommended. Inspect and clean the strainer periodically as a dirty strainer screen can cause enough vaporization to make the pump capacity drop and the wear rate increase. New installations should be inspected frequently until the initial accumulation of dirt, weld splatter, etc., is flushed from the system.

# OPERATION

## PIPING

Many pump systems deliver at a rate below the designed capacity of the pump because the system was improperly piped. Use pipe of adequate size and strength, at least equal to the pump inlet size on short piping. Use unrestricted fittings, especially in the intake piping, to avoid vaporization. Avoid the use of globe valves in the intake piping. Gate or ball valves are less restrictive. Flexible connectors in the intake and discharge piping will result in a much quieter operation.

The external bypass line should not be less than ½" pipe. This return line can go to either the liquid or vapor section of the tank with a minimum amount of restriction. The maximum recommended back pressure on the bypass is 5 psi. Unions and valves in the piping near the pump will facilitate maintenance. On the intake side locate the nearest fitting at least 6 inches from the pump to permit the removal of the pressure relief valve cover.

New piping should be thoroughly flushed before connecting to the pump. If the piping is to be out-of-doors, allowance should be made for expansion and contraction. Piping should be well supported so as not to impart a strain on the pump.

## MOTOR INFORMATION (LGF MODELS ONLY)

The motors supplied with the pumps are 60 cycle, 1800 RPM, single phase, explosion proof motors rated for continuous duty. Information as to type, model number, horsepower full-load amperage, etc. is shown on the motor nameplate.

Motors can be connected for 230 volt operation, CCW Rotation, or for 115 volt service by changing the lead connections according to the wiring diagram attached to the motor. Always check connections before attaching motor to power source.

These motors are equipped with a Thermal Overload Protector which will cut off power if motor becomes overheated. This Overload Protector depends on the temperature rise in the motor together with ambient temperature. It is designed to allow approximately 20% overload for short periods of time (such as the short period needed to fill propane bottles) at normal ambient temperatures. If the Overload Protector cuts out, check the pressure relief valve setting on the pump, check for free turning of the pump and for proper wiring and voltage. Low voltage at the motor will cause the Overload Protector to trip. This may be due to excessive service length or inadequate wire sizing. Shading the motor from direct sunlight will help reduce the ambient temperature. If the Thermal Overload Protector cuts out repeatedly and the cause cannot be determined, take the motor to an authorized motor repair shop.

## CONNECTING THE MOTOR

Carefully inspect the motor-and-pump for shipping damage before connecting power to the motor.

Lead wires to the motor should be run through rigid metal conduit with threaded, explosion-proof joints and explosion-proof condulets for Class I, Group D Service. Follow state and local regulations.

It is important to use wire of adequate size from power source to motor leads. This work should be performed by qualified personnel.

## PERFORMANCE CHECK

The unit should be thoroughly checked before being put into operation.

Check to make sure that pipes are properly supported so that there is no strain on the pump. When a union joint is broken, pipes should not spring away or drop down.

Install a pressure gage in the ¼" tapped hole on the top of the pump nearest the discharge port. Open all valves in the lines to the pump.

Check wiring diagrams for proper connections for voltage and rotation.

Start the unit and check the rotation against the arrow on the pump. The motor should start immediately and quickly come to its operating speed. If it does not, shut off the motor and refer to "Motor Troubles and Their Cures" for possible causes.

Inspect the pump for noise, vibration, leakage, overheating, capacity, etc. If there is any malfunction, refer to "Pump Troubles and Their Cures" for probable cause and remedy.

## PUMP INTERNAL RELIEF VALVE AND BYPASS VALVE

With pump operating, slowly close the valve in the pump discharge line. The manual valve in the bypass line should be open. Read the peak pressure on the gage on the pump. As the valve in the discharge line is closed the pump discharge pressure will rise to a maximum value, then drop back slightly. Use the maximum pressure to determine valve setting. Read the pressure gage in the supply tank or in-take line. If the difference between these gage readings does not equal the pressure stamped on the pump relief valve tag or the desired pressure, adjust the pump valve setting. Turn adjusting screw in to raise the setting, turn out to lower setting. Note that if you operate the pump with both the discharge line and separate bypass line closed the internal relief valve will open. The pump will recirculate, vaporizing the liquid and creating noise until the bypass line is opened. The pressure gage may also read lower than with normal operation.

# MAINTENANCE

## LUBRICATION

The pump bearings should be lubricated every three (3) months with a light No. 2 Lithium-base type of grease.

Apply grease slowly with a hand gun to the grease fittings on each bearing cover until excess grease begins to come from the relief fittings. It is normal for some grease to escape from the tell-tale holes under the bearing covers for a short period

after lubrication. If this condition persists, the head must be removed and mechanical seal examined for wear or damage. A small amount of liquefied gas may be leaking past the seal and gradually washing grease out of the bearing chamber. Where gas is noticeable escaping from the tell-tale holes, the entire mechanical seal must be replaced.

For extreme low temperature service in Northern climates, the pump should be lubricated with a low temperature grease.

Following are some of the low temperature greases which may be used for this service:

- Standard Oil – Super Mil 42901
- Shell Oil – B & B No. 70919
- Mobil Oil – Grease No. 22
- Exxon – Beacon 325

The motor bearings are sealed and require no periodic lubrication.

## OVERHAUL OR REPAIR

### TOOLS:

The worn or defective parts can be replaced using the following:

- a. Small blade screw driver
- b. Small hammer
- c. 2 Pr. Vise-Grip pliers
- d. Long handle Box/open end wrench
- e. One-half of the drive coupling and Key

### DISASSEMBLY

Lock nuts are secured by a deformed lockwasher tang. This tang must be pried out of one slot, in the lock nut, with a small blade screwdriver. After removing both lock nuts and lockwashers remove the four (4) head capscrews. While holding the cylinder, tap the drive end of the rotor shaft and the pump will pop apart. Use caution to avoid getting dirt into the bearing grease and to not damage the mechanical seals. Remove the combination bypass and relief valve.

Visually check all parts for wear and physical damage. Replace all defective parts. A groove around the cylinder bore or back wall makes that part unusable. These same conditions apply to the head wall.

### ASSEMBLY

#### NOTE

The rotor and shaft is used as an assembly pilot guide to get alignment between the cylinder and the head.

1. Apply a light coating of grease or oil to the "O" rings and insert the mechanical seal assembly into the cylinder. Insert a ball bearing (shield side inboard).
2. Insert the drive end of the rotor shaft, through the mechanical seal and bearing. Push the rotor into the cylinder and rotate to engage the seal drive tangs.
3. Install the tanged lockwasher and lock nut. Using vise-grips, tighten the lock nut to pull the rotor down tight against the cylinder back wall.

4. Using a shop cloth for shaft protection, tighten the drive end of the rotor shaft in a vise. Insert the four (4) vanes.
5. Insert the head "O" ring, mechanical seal assembly, and bearing (shield side inboard) in the head. Place this assembly over the outboard end of the rotor shaft.
6. Press down and rotate the head, to engage the seal drive tangs, then just start the four (4) head capscrews.
7. Install the tanged lockwasher and start the lock nut. Grasp and clamp the lock nut in vise-grips. Use the vise-grip clamped lock nut to pull the head down very tight. It is desirable to wiggle the head while tightening the lock nut.
8. Tighten the four (4) head capscrews before loosening the outboard lock nut then loosen both lock nuts three (3) or more turns.
9. Using a keyed coupling half, check that the rotor turns free with only seal drag. Catches or high torque spots require tear down and correction.
10. Tighten the drive end lock nut, with vise-grips, until a moderate rotor drag is felt when turning the rotor shaft with the coupling half.
11. Locate the closest lockwasher tang and lock nut slot. Align that slot and tang and stake the tang into the slot.
12. Clamp the coupling half and the outboard lock nut firmly in vise-grips. Tighten the outboard lock nut approximately one-eighth (1/8) of a turn past the point where rotor drag disappears.
13. Remove both vise-grips, turn rotor shaft with coupling half and check for free turning (no metal-to-metal rotor drag). Align the closest slot and tang and stake the tang into the slot.
14. Install the bearing cover and bracket, then lubricate both inboard and outboard bearings.
15. Install the bypass/relief valve making certain the valve slides freely and the disc is properly located in the valve. Insert the valve spring and install the valve cover.

## PUMP TROUBLES AND THEIR CURES

### LOSS OF DELIVERY

The most probable causes for failure to pump or loss of delivery are: closed valve in the pipe line, closed excess flow valve at tank outlet, pump installed backwards (discharge port located on the intake side of the system), vapor binding, damaged vanes, or boiling liquid in the intake line.

### NOISE AND VIBRATION

Noise and vibration are usually caused by cavitation (vapors entering the pump), often the result of restrictive intake piping, globe valves, or some types of tank outlet valves. Plugged strainer baskets or the mesh being too fine may cause cavitation. Circulation of liquefied gas through the built-in relief valve may cause noise and vibration. Cavitation accelerates pump wear.

### LEAKAGE

Mechanical seal leakage will show up at the drain holes on the bottom of the pump cylinder and the head. Examine the mechanical seals and replace if damaged.

If after rebuilding a pump, leakage appears from between the pump cylinder and head, the head must be removed and the head "O" ring replaced.

### MOTOR TROUBLES AND THEIR CURES

If the motor fails to start or does not attain its proper speed, it may not be properly connected to the switch box, or the voltage may be too low. The load may be too great, causing the Thermal Overload Protector to cut out.

Low voltage is frequently the result of using undersize wire between power source and switch box. The power source should be checked for low voltage.

Overloading is quite often the result of high differential pressure at the pump. Check the differential pressure against the recommended maximum for the motor horsepower.

If the trouble cannot be traced to any of these causes, take the motor to an authorized motor repair shop.

# BLACKMER PUMP PARTS LIST

MODELS: LGF1C, LGB1C, LGF1PC, LGB1PC

(See Instructions 585/A for Operation and Maintenance)

960401

PARTS LIST NO. 585/A1

Section

500

Effective

November 1988

Replaces

May 1985

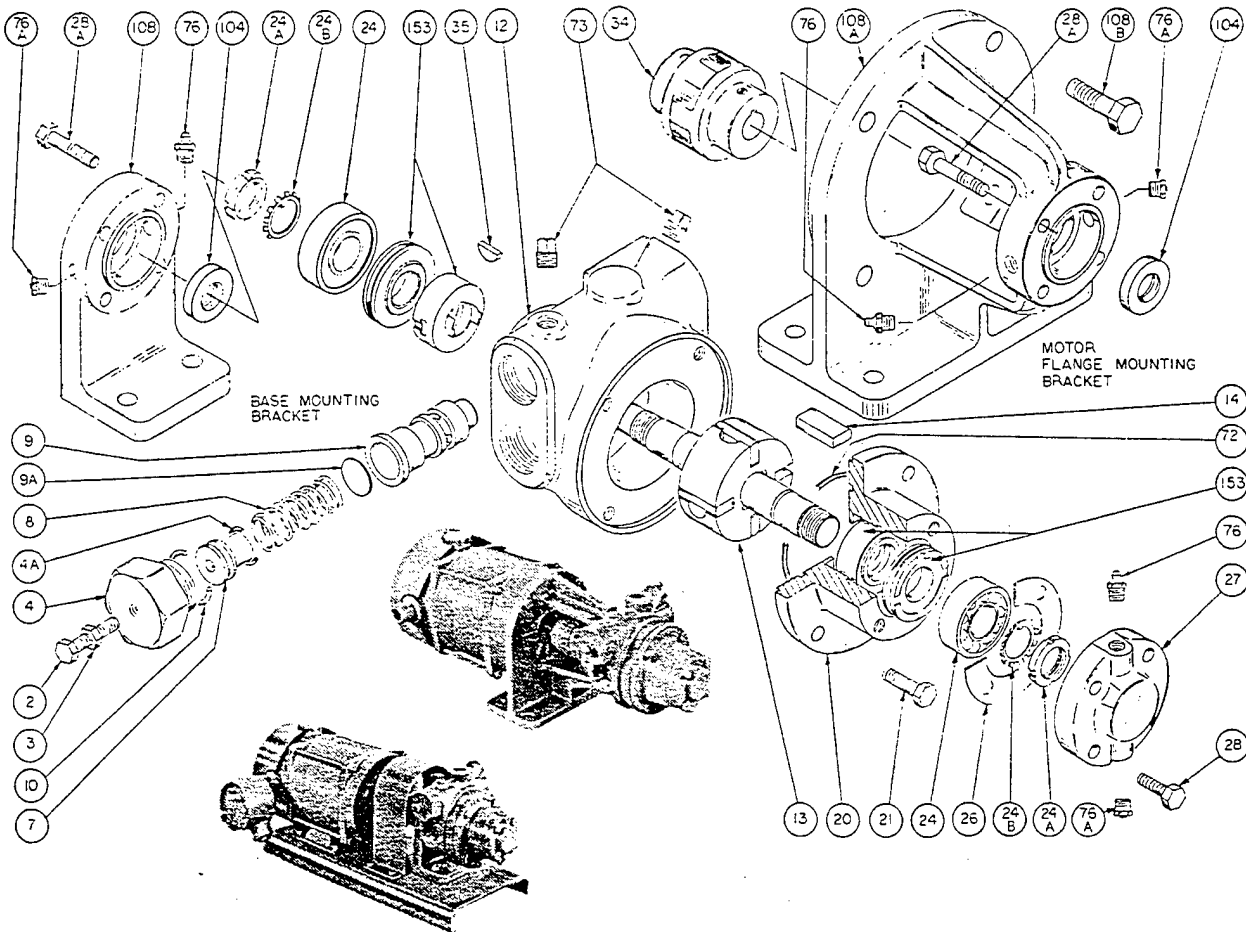

REF. NO.	PART NAME	PARTS PER PUMP	PART NO.	REF. NO.	PART NAME	PARTS PER PUMP	PART NO.
2	Adjusting Screw - Relief Valve (R/V)	1	432901	26	Gasket - Bearing Cover	1	*382901
3	Locknut - Adjusting Screw	1	922811	27	Bearing Cover	1	042901
4	Cover - R/V	1	412901	28	Capscrews - Bearing Cover	4	920203
4A	O-Ring - Spring Guide	1	*711940	28A	Mounting Screws	4	920230
7	Spring Guide - R/V	1	422901	34	Coupling Half - Pump	1	906139
8	Spring - R/V	1	*472901		Coupling Half - Motor (143T, 145T, 184 Frame)		906143
9	Valve - R/V	1	*452901		Coupling Half - Motor (56, 56C Frame)		906141
9A	Disc - R/V	1	*442901		Coupling Spider		906154
10	O-Ring - R/V Cover	1	*701965	35	Key - Shaft	1	*909126
12	Cylinder - LGF1, LGB1	1	022902	72	O-Ring - Head	1	*711941
	Cylinder - LGF1P, LGB1P		022911	73	Gage Plug	2	908195
13	Rotor & Shaft Assembly (Includes Ref. No. 24A)	1	262901	76	Grease Fitting	2	317815
14	Vane - Duravane (Std.)	4	*092912	76A	Grease Relief Fitting	2	701992
	Vane - Laminate		092909	104	Grease Seal	1	*331934
20	Head	1	032902	108	Bracket - LGB1 & 1P	1	832901
21	Capscrews - Head	4	920178	108A	Bracket - LGF1 & 1P	1	832905
24	Ball Bearing	2	*903405	108B	Capscrews - Bracket	4	920331
24A	Locknut - Bearing	2	903531		Pump Repair Kit		892950
24B	Lockwasher - Bearing	2	*903532				

\* Parts Included in Pump Repair Kit.

PARTS LIST NO. 585/A2

MECHANICAL SEAL - STANDARD

REF. NO.	PART NAME	PARTS PER PUMP	PART NO.
153	Mechanical Seal Assembly	2	*332920
153A	Jacket Assembly - Seal	2	332922
153B	Stationary Seat (Steel)	2	332901
153D	O-Ring - Stationary (Buna-N)	2	711916
153F	Seal Face (Carbon)	2	332902
153G	O-Ring - Rotating (Buna-N)	2	711939

\* Included in Pump Repair Kit.

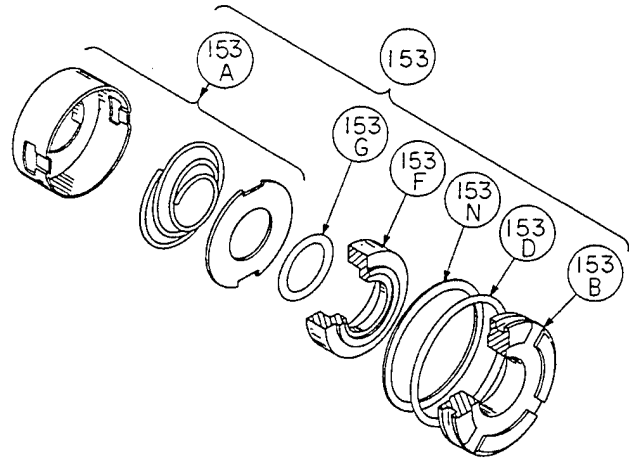

MECHANICAL SEAL - OPTIONAL (MAPP GAS)

REF. NO.	PART NAME	PARTS PER PUMP	PART NO.
153	Mechanical Seal Assembly	2	332921
153A	Jacket Assembly - Seal	2	332922
153B	Stationary Seat (Steel)	2	332901
153D	O-Ring - Stationary (Viton)	2	711908
153F	Seal Face (Carbon)	2	332902
153G	O-Ring - Rotating (Viton)	2	711942
153N	Seal Backup Ring (Steel)	2	332906

ELECTRIC MOTORS			SWITCH BOX	
PUMP MODEL	DESCRIPTION	PART NO.	PART NO.	DESCRIPTION
LGF1, LGF1P	(1800 RPM, Explosion Proof, 60 Cycle Motors)			Double Pole, 20A @ 125V & 10A @ 250V Explosion Proof
	1 HP, 56C frame, single phase, 115/230 volt	929977	929980	
	1 HP, 56C frame, three phase, 230/460 volt	929928	n/a	
	1½ HP, 56C frame, single phase, 115/230 volt	929982	929980	
1½ HP, 56C frame, three phase, 230/460 volt	929930	n/a		
LGB1, LGB1P	(1800 RPM, Explosion Proof, 60 Cycle Motors)			
	1 HP, 56 frame, single phase, 115/230 volt	929919	929980	
	1 HP, 145T frame, three phase, 230/460 volt	929011	n/a	
	1½ HP, 184 frame, single phase, 115/230 volt	929920	929980	
1½ HP, 145T frame, three phase, 230/460 volt	929014	n/a		

# BLACKMER LIQUEFIED GAS PUMPS FOR LP-GAS AND NH<sub>3</sub> SERVICE

INSTALLATION, OPERATION, AND MAINTENANCE INSTRUCTIONS  
MODELS: LGRL(F)1¼, LGL(F)1¼, LGL1½

960409

INSTRUCTIONS NO. 585/C

Section	500
Effective	November 1988
Replaces	June 1984

## GENERAL INFORMATION

### SAFETY RULES

It is recommended that NFPA Pamphlet 58 be consulted for Safety Rules. Consult local and state regulations also.

### WARNING

**THIS PRODUCT MUST ONLY BE INSTALLED IN SYSTEMS WHICH HAVE BEEN DESIGNED BY THOSE QUALIFIED TO ENGINEER SUCH SYSTEMS. THE SYSTEM MUST BE IN ACCORDANCE WITH ALL APPLICABLE REGULATIONS AND SAFETY CODES AND WARN OF ANY HAZARDS UNIQUE TO THE PARTICULAR SYSTEM.**

### WARNING DANGER

**DO NOT ATTEMPT TO OPEN THE PUMP UNTIL YOU HAVE BLEDED OFF THE PRESSURE. ON SYSTEMS WITH METERS, THE DIFFERENTIAL VALVE WILL KEEP LIQUID UNDER PRESSURE IN THE PUMP, METER AND PIPING EVEN WHEN THE HOSE IS EMPTIED.**

### PUMP DATA

	LGRL(F)1¼	LGL(F)1¼	LGL1½
Nominal Capacity (GPM) (1800 RPM - 50 psi) (1800 RPM - 345 kPa) at Ambient Temperature of:			
80°F (27°C)	16	21	33
32°F (0°C)	13	17	26
(1200 RPM - 50 psi) (1200 RPM - 345 kPa) at Ambient Temperature of:			
80°F (27°C)	—	13	20
32°F (0°C)	—	10	16
Maximum Differential Pressure	150 psi (1034 kPa)		
Maximum Temperature	240°F (115°C)		
Maximum Pump Speed	1800 RPM		

These pumps are listed by Underwriters' Laboratories, Inc. for liquefied-petroleum gas and NH<sub>3</sub>.

## INSTALLATION AND OPERATION

### LOCATION

Locate the pump as near the source of supply as possible to reduce pipe friction. A good foundation reduces vibration and noise and improves the pump performance. On permanent installations, it is recommended that the pumping units be securely bolted to a concrete foundation. When new pump foundations are to be cast in concrete, it is suggested that anchor bolts of the type shown in Fig. 1 be set into the concrete.

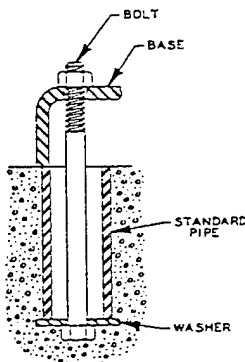

Fig. 1

This type of bolt allows for slight shifting of position to better line up with the mounting holes in the base plate. When pumps are to be located on existing concrete floors, holes should be drilled into the concrete and foundation bolts anchored therein.

### RELIEF VALVE & BYPASS VALVE

The built-in spring loaded relief valve is to prevent damage to the pump or pumping system from excess pressure, and should not be used for recirculation. A separate bypass valve, such as the Blackmer Model BV3/4 or BV1, is required by Underwriters' Laboratories, Inc. to be piped from the pump discharge system back to the supply tank (see Figure 2). The setting on the separate by-pass valve should be at least 25 psi (172 kPa) less than the relief valve setting. Do not pipe the bypass valve back to the intake line. The valve and piping should be of adequate size to accommodate the full flow from the pump when the discharge line is closed and the pump is running at its normal maximum speed.

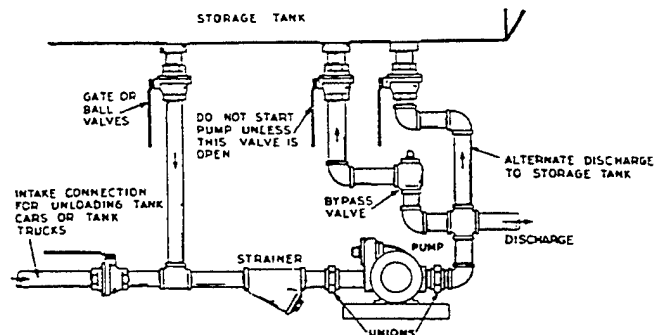

Fig. 2

## STRAINER

A strainer is recommended to protect the pump from damage by foreign particles. Generally, the strainer should be installed in the inlet line close to the pump, and should have a net open area of at least four times the area of the pump intake pipe. For more specific applications, refer to the manufacturer's recommendation for proper installation and sizing of the strainer. The strainer should be inspected and cleaned at regular intervals.

## PIPING

Many pump systems deliver at a rate below the designated capacity of the pump because the system was improperly piped. Restrictions in the pipe line such as elbows, sharp bends, globe valves, certain restrictive-type plug valves and undersized strainers, should be avoided. Use gate or ball valves, not globe valves. The inlet line should slope downward to the pump, never upward or with upstanding loops. Use pipe of adequate size and strength that has been thoroughly flushed before connecting to the pump. Flexible connectors used near the pump will compensate for expansion contraction and will provide a more vibration-free operation.

On the intake side, locate the nearest fitting at least six inches from the pump to permit the removal of the relief valve cover.

Whenever possible, keep liquefied gas systems full of liquid, even when idle. This will keep the O-rings from changing shape, shrinking or super-cooling. Evaporation of liquefied gas leaves an abrasive powder on the surface which can cause wear to the pump, seals, meter, etc.

Use a vapor return line if possible. This will speed up delivery since a vapor line prevents back-pressure from building up at the receiving tank and a vacuum from forming in the supply tank. In laying out the system, read the section on "Pump Troubles and Their Cures" for suggested ways to eliminate difficulties before they develop.

## ALIGNMENT

Coupling alignment on stationary units should be checked after anchor bolts are tightened.

Where flexible couplings are used, the coupling cover should be removed and a straight edge laid across the two hubs of the coupling as shown in Fig. 3. The maximum offset should be less than .015 " (.381mm).

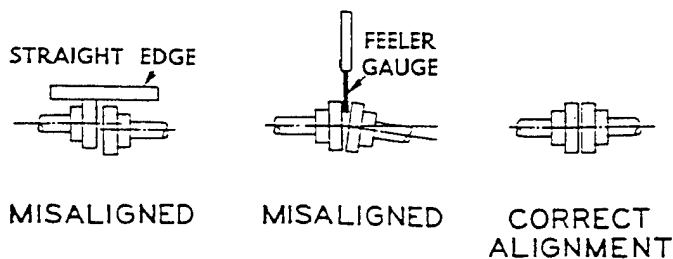

Fig. 3

With a feeler gage or piece of flat steel of proper thickness, check the space between the two coupling valves. Insert a gage at a point on the coupling and at 90° increments about the coupling. The space should not vary more than .020" (.508mm). Misalignment is not desirable. If it does exist, it must not exceed the above limits.

Check the alignment of the pipes to the pump to avoid strains which might later cause misalignment. To check, break union joints; pipes should not spring away or drop down.

## OPERATIONAL CHECK

The installation should be checked before being put into operation. Install a pressure gage in the gage hole nearest the discharge port provided on the pump casing before starting. Check all valves. The valve in the bypass return line must be open. After the pump is started, check the direction of shaft rotation to be sure it matches the direction of the arrow on the pump.

With the pump in operation, slowly close the valve in the pump discharge line. This forces the pump output to go through the separate bypass valve. Subtract the inlet pressure from the pump discharge pressure gage reading, to obtain the system differential pressure that is determined by the adjustment on the separate bypass valve. Adjust the separate bypass valve to obtain a system differential pressure that is at least 15 psi (103 kPa) higher than the maximum required differential pressure. The pinned locknut, on the separate bypass valve adjustment screw, sets the maximum differential pressure adjustment permitted. Close the discharge line from the separate bypass valve back to the tank, and adjust the internal pump relief valve to a differential pressure that is 25 psi (172 kPa) greater than the separate bypass valve differential.

To increase the pressure setting on the pump relief valve, remove the relief valve cap from the adjusting screw, loosen the locknut, and turn the adjusting screw clockwise or inward. To reduce the pressure setting, turn the screw counterclockwise, or outward.

Check the general performance of the unit: gallons per minute delivered, noise level (if any), signs of overheating, vibration, leakage, etc. If there is any malfunction, refer to "Pump Troubles and Their Cures."

## TO REVERSE PUMP ROTATION

Remove the bearing covers from both heads, the bearing lockwashers and locknuts from the shaft, and the head from the shaft side. Reverse the rotor and shaft so that the shaft protrudes through the head still on the casing. The vanes must be reversed in the slots so that the pressure relief grooves face in the direction of rotation. The rounded or wearing edge of the vanes must be outward to contact the liner. See "Maintenance" for removal and replacement of heads and rotors.

# MAINTENANCE

**MAINTENANCE AND TROUBLE SHOOTING MUST BE DONE BY AN INDIVIDUAL EXPERIENCED WITH PUMP MAINTENANCE AND THE TYPE OF SYSTEM INVOLVED.**

## LUBRICATION

Pump bearings should be lubricated every three months.

Use Standard Oil — Amolith All Weather Grease, or an equivalent grease which is compatible with the elastomers and the application.

**CAUTION:** Excessive greasing pressure can cause grease to be pushed between the mechanical seal faces causing seal failure.

It is recommended that you remove the grease relief fitting, and with a hand gun apply grease slowly to the grease fittings on both bearing covers until excess grease begins to come from the grease relief fitting port. Replace the grease relief fittings before putting the pump into operation. It is normal for some grease to escape from the tell-tale holes under the bearing housing for a short time after lubrication.

## DISASSEMBLY

Before work is started on a pump, be sure the liquid is drained and the gas pressure relieved.

Remove the bearing cover capscrews and slide the bearing cover off the shaft. These pumps are protected from "end thrust" by a lockwasher and locknut installed outside the bearing on each end of the shaft. Remove the bearing locknut after bending up the engaged lockwasher tang and rotating the nut counterclockwise.

Check for burrs or roughness on the shaft that could damage the mechanical seal O-ring when the head is removed. Remove the head capscrews. Each head is located by two (2) tapered pins, and has a threaded jackscrew hole to facilitate removal. Insert a bearing cover capscrew in the jackscrew hole to pull the locating taper pins out of the housing.

When the head is removed, the stationary seat of the mechanical seal will come off with the head. The rest of the mechanical seal, including the jacket assembly and the rotating seal face and O-ring, can then be slid from the shaft as a complete unit. It is important to keep all parts of the seal clean, and to keep the seals matched as a set.

If the mechanical seal has been leaking, it is advisable to replace the entire seal, including the stationary seat and its O-ring.

Slide the disc and head O-ring off the shaft. Inspect the vanes for damage. If the outer edges of the vanes are torn or chipped the vanes should be replaced. If the vanes are found to be damaged, it is advisable to pull the rotor and shaft and check the liner for damage also. A badly worn or damaged liner should be replaced. Using a brass or hard wood drift, with a hammer, tap the liner around its outside diameter to drive it out of the casing.

Some scoring of the rotor O.D. may occur due to weld splatter or other abrasives in the fluid. If this condition has occurred, remove any burrs from the vane slots and check the push rods (four-vane rotor only) for free movement in the push rod holes. Binding push rods will require replacement of the rotor and shaft assembly.

## REPLACING VANES ONLY

When replacing only the vanes, it is advisable to remove the head opposite the drive end for this purpose. Turn the rotor by hand until the vanes appear at the 11 and 1 o'clock positions. Remove these two vanes and install new ones. The rounded or wearing edge of the vane must be outward to contact the liner, and the relief grooves must face in the direction of rotation. Repeat this operation until all new vanes are in place.

**NOTE:** For replacement of other pump parts, refer to the following "Assembly" Section.

## ASSEMBLY

Before reassembling the pump, clean each part thoroughly. Wash out bearing and seal recesses.

Start the liner into the casing. Make sure the embossed word "INTAKE" on the liner, is positioned towards the intake port on the pump casing. The liner keyway must be aligned with the pin that extends down into the bore of the casing. Lightly tap the outer edge of the liner with a plastic or lead hammer to fully insert the liner into the casing.

Install the disc, cavity side out, with the disc relief hole located on the discharge side of the pump, approximately 45° from the base of the pump (see Figure 4).

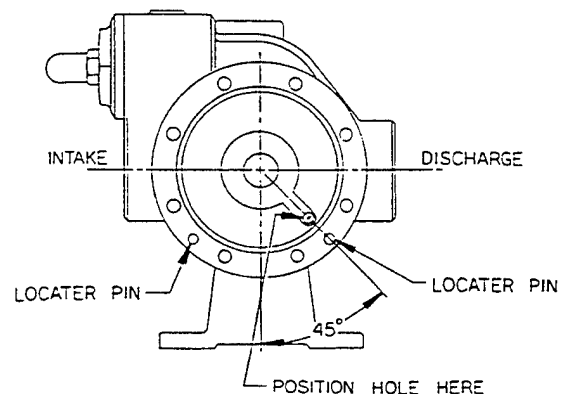

Fig. 4 — Disc Hole Location

The head O-ring should be replaced if it is swollen, nicked or cut. Install the head O-ring in the groove between the disc and the pump casing.

To install the mechanical seal, place the seal jacket assembly in the disc cavity with the drive tang in the center hole. Align and install the carbon rotating seal face and its O-ring in the seal jacket assembly with the polished, or mating face outward. With the pump head resting flat and its seal recess facing up, install the stationary seat and its O-ring into the recess of the head. The pin of the stationary seat must be engaged in either slot in the bottom of the recess. The polished or mating face of the stationary seat should face outward. It is important to keep both seal faces free of all traces of dirt, grease, or oil. A clean tissue paper and alcohol should be used to clean the seal faces.

Place the bearing into the bearing bore of the head with the grease shield towards the inside, so that the balls are visible after installation.

Attach the head assembly to the casing. Use the taper pins to locate and center the head. Note: The heads are not interchangeable, and must be attached on the same ends from which they were removed. Install and tighten the head capscrews.

Before the rotor and shaft can be installed, the direction of pump rotation must be determined. If the pump is to be right-hand (clockwise rotation), the intake port and relief valve must be on the right, with the drive end of the pump's shaft pointing towards the observer. If the pump is to be left-hand (counterclockwise rotation), the pump must have the intake port and relief valve on the left, with the drive end of the pump's shaft pointing towards the observer.

Thoroughly clean the shaft and remove all burrs or roughness with emery. Put a light coating of clean, light oil on the shaft, between the threads and the rotor on both sides of the rotor.

On pumps equipped with a four-vane rotor and shaft, to prevent the push rods from dropping into the intake or discharge ports and jamming the rotor, hold the two bottom vanes in place and install the push rods (see Figure 5). Carefully insert the correct

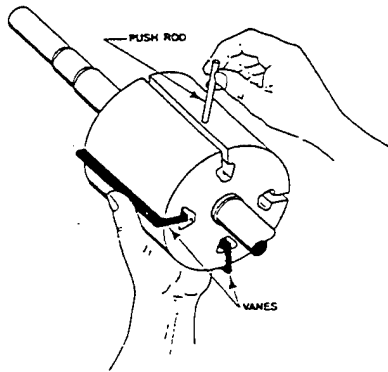

Fig. 5 — Push Rod Installation

end of the shaft through the seal assembly in the installed head (refer to pump rotation in preceding paragraph). To install the two remaining vanes, turn the shaft by hand until an empty slot comes to the 12 o'clock (top) position, insert a vane and rotate to the next empty slot. Be careful not to rotate an empty vane slot towards the bottom of the pump or the push rods will drop and jam the rotor.

On pumps equipped with an eight-vane rotor and shaft, no push rods are used. Insert the correct end of the rotor and shaft through the seal assembly in the installed head. Install the vanes by rotating the shaft by hand until an empty slot comes to the 12 o'clock (top) position, insert a vane and rotate to the next empty slot. Continue this process until all eight (8) vanes are in place.

On both the four-vane, and the eight-vane rotor and shaft, the vanes must be installed with the rounded or wearing edge outward to contact the surface of the liner. The relief grooves must face in the direction of rotation.

After the rotor and shaft and vanes have been installed, slowly rotate the shaft by hand to engage in the seal drive tang.

Install the second disc, head O-ring, ball bearing, and seal jacket assembly in the same manner as previously instructed. Press down while rotating the seal jacket assembly to engage the seal drive tang.

Install the stationary seat of the mechanical seal in the head recess. Attach the head assembly to the casing using the taper pins to locate and center it. Be careful not to contaminate the mechanical seal faces. Install and tighten the head capscrews.

Before installing the bearing lockwashers and locknuts tap the outer race of the bearing to ensure that it is properly seated in its cavity. Install a lockwasher and locknut on both ends of the shaft. Tighten the locknuts with the use of a spanner wrench and tap the bearings again for proper seating. Loosen both locknuts and rotate the shaft. The shaft must turn, with a light uniform seal drag, in both directions.

To adjust the locknuts, first tighten the locknut on the driver end until a slight drag increase is noted. Next, tighten the bearing locknut on the outboard end until the increase drag is eliminated. Find, align, and stake the closest lockwasher tang into the slot on the locknut. Repeat this operation for the locknut on the opposite end of the shaft.

Apply a small amount of grease to the lip of the grease seal and insert it in the inboard bearing cover with the lip outward. Attach a bearing cover gasket and bearing cover on each end.

# PUMP TROUBLES AND THEIR CURES

## LOSS OF DELIVERY

Probable causes:

1. Cavitation caused by circulation of liquid through the relief valve. This might happen if the separate bypass valve is too small, or if the piping to the valve is too small.
2. Lack of a vapor return will cause high discharge pressure, a vacuum in the supply tank, and resulting cavitation. If a vapor line is being used, it should be sized to allow minimal restriction of vapor flow. Where such a line is not permitted, vapor space filling (spray) valves should be used to keep pressure down to a reasonable level. When no vapor return line is used, the maximum delivery rate is limited to approximately 2½ percent of the tanks capacity per minute. This will vary somewhat with temperatures of the liquid and atmosphere, and resistance in the intake line.
3. Reversed pump rotation. Check the rotation of the pump with the arrow on the casing. The arrow must point in the direction of pump rotation.
4. Restriction in the suction line, caused by closed valves or too long of a suction line. Locate the pump as close to the supply as possible. It is easier for a pump to push liquid through a discharge pipe than to pull it through a suction pipe because of the tendency of these liquids to vaporize when the pressure drops.
5. Resistance in the discharge line.
6. Excessively worn vanes, discs, and rotor ends will increase pump slippage. One or more vanes installed backwards may reduce capacity.
7. Cold weather will increase the size of vapor bubbles in the inlet line thereby displacing a larger amount of liquid in the system, reducing flow.

## LEAKAGE

Mechanical seals can be damaged and will begin leaking due to the following: greasing with a high pressure gun, using the wrong grease, dirt or abrasive particles between the seal faces, cut or otherwise damaged O-rings. Leakage will appear at the tell-tale holes under the bearing housing on the pump head. If leakage becomes excessive, the entire mechanical seal assembly should be replaced.

If leakage appears from between the pump casing and the head, the head should be removed and its O-ring inspected for cuts and nicks. If the O-ring is damaged, it should be replaced.

## EXCESSIVE WEAR OR DAMAGED PARTS

Excessive wear and damaged pump parts are most often the result of the following:

Excessive vane wear is usually caused by:

- a. Running dry
- b. Overspeeding
- c. Dirt "abrasives" in the line

Push rod penetration (four-vane rotor and shaft only) is usually caused by:

- a. Overspeeding
- b. Cavitation
- c. Worn vane slots
- d. Corrosion in push rod hole area

Corrosion of pump parts can be caused by water or carry-over from dehydrators. Corrosion may damage internal parts and weaken the entire system. Corrective action should be taken, immediately, to eliminate the cause.

Worn or scored discs and rotor ends are usually caused by improper adjustment of the bearing locknuts. Unless the locknuts are drawn up evenly as previously instructed in "Assembly," end-play will permit rotor and disc contact, causing wear.

## NOISE AND VIBRATION

Noise and vibration are usually the result of cavitation (see causes above). Noise and vibration may also be caused by: vanes installed backwards (see Replacing Vanes), liner installed backwards, a broken vane, or by an improperly designed drive line which may impart a surging vibration to the pumping system.

Recirculation through the pump relief valve can also cause noise. Check the setting of the separate bypass valve.

***blackmer***

A **DOVER** RESOURCES COMPANY

1809 Century Avenue, Grand Rapids, Michigan 49509, U.S.A.  
(616) 241-1511 • Telex: 432014R • Fax: (616) 241-2750

# BLACKMER PUMP PARTS LIST

MODELS: LGRL1 $\frac{1}{4}$ , LGRLF1 $\frac{1}{4}$ , LGL1 $\frac{1}{4}$   
LGLF1 $\frac{1}{4}$ , LGL1 $\frac{1}{2}$

(See Instructions 585/C for Operation and Maintenance)

960410

PARTS LIST NO. 585/C1

Section  
Effective  
Replaces

500  
April 1990  
November 1988

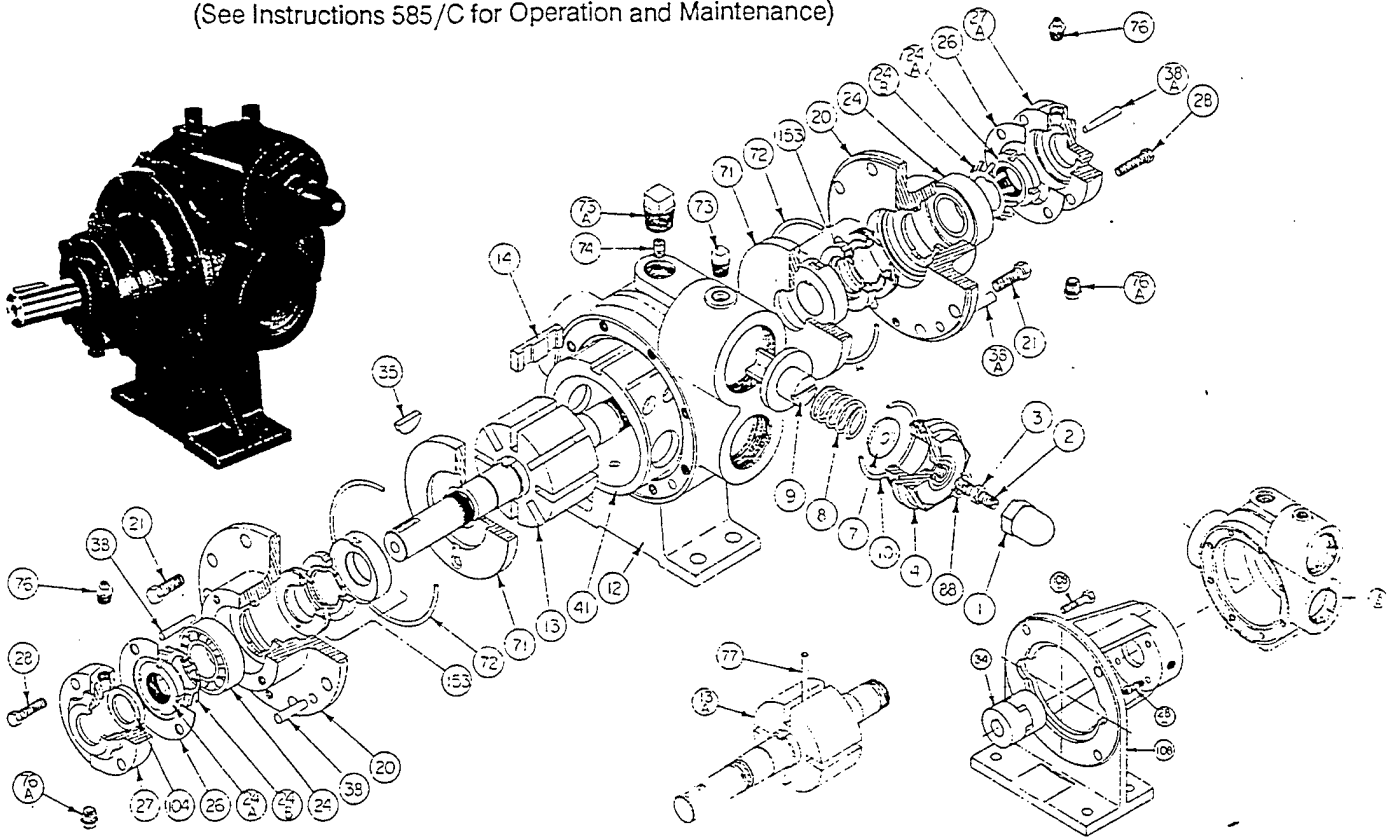

REF. NO.	PART NAME	PARTS PER PUMP	PART NO.	REF. NO.	PART NAME	PARTS PER PUMP	PART NO.
1	Cap - Relief Valve (R/V)	1	413200		Liner - LGRL(F)1 $\frac{1}{4}$		183003
2	Adjusting Screw - R/V	1	433909	41	Liner - LGL(F)1 $\frac{1}{4}$	1	183004
3	Locknut - Adjusting Screw	1	922923		Liner - LGL1 $\frac{1}{2}$		183301
4	Cover - R/V	1	413076	71	Disc	2	*063075
7	Spring Guide - R/V	1	423955	72	O-Ring - Head	2	*701918
8	Spring - R/V (81-150 psi)	1	*471428	73	Gage Plug (1/4")	1	908195
9	Valve - R/V (Std.)	1	*453077	73A	Gage Plug (1/2")	1	908215
	Valve - R/V (Nickel Plated)		452300	74	Setscrew - Liner	1	922088
10	O-Ring - R/V Cover	1	*711924	76	Grease Fitting	2	317815
12	Casing (1 $\frac{1}{4}$ )	1	013075	76A	Grease Relief Fitting	2	701992
	Casing (1 $\frac{1}{2}$ )		013376		Push Rod - LGRL(F)1 $\frac{1}{4}$		*123004
13	Rotor & Shaft Assy. Eight-Vane (Std.) (Includes Ref. Nos. 24A & 24B)	1	262300	77	Push Rod - LGL(F)1 $\frac{1}{4}$	0 - 2	*123076
13A	Rotor & Shaft Assy. Four-Vane (Includes Ref. Nos. 24A & 24B)	1	263076		Push Rod - LGL1 $\frac{1}{2}$		*123401
14	Vane - Duravane (Std.)	4 - 8	*093088	88	O-Ring - R/V Cap	1	*701949
	Vane - Laminate		093089	104	Grease Seal	1	*331927
20	Head	2	033073		Pump Repair Kit - LGRL(F)1 $\frac{1}{4}$		892302
21	Capscrews - Head	16	920276		Pump Repair Kit - LGL(F)1 $\frac{1}{4}$		892301
24	Ball Bearing	2	*903114		Pump Repair Kit - LGL1 $\frac{1}{2}$		892600
24A	Locknut - Bearing	2	903534		FLANGE MOUNTING		
24B	Lockwasher - Bearing	2	*903533	12A	Casing w/o Feet (F1 $\frac{1}{4}$ )	1	013077
26	Gasket - Bearing Cover	2	*383075	28A	Mounting Screws	4	920101
27	Bearing Cover - Inboard	0 - 1	043070		Coupling Half - Pump		906143
27A	Bearing Cover - Outboard	1	043071		Coupling Half - Motor (56C Frame)		906141
28	Capscrews - Bearing Cover	4 - 8	920080	34	Coupling Half - Motor (56C2 Frame)	1	906143
35	Key - Shaft	1	*909125		Coupling Spider		
38	Taper Pin (#2 x 1")**	2	930037	108	Mounting Bracket	1	923000
38A	Taper Pin (#3 x 1 $\frac{1}{4}$ ")**	2	930075	108B	Capscrews - Bracket	4	920331

\* Parts Included in Pump Repair Kit.

\*\* Pumps with serial numbers below 276745-N require taper pins p/n 930075 & p/n 930141.

PARTS LIST NO. 585/C2

MECHANICAL SEAL - STANDARD

REF. NO.	PART NAME	PARTS PER PUMP	PART NO.
153	Mechanical Seal Assem:	2	*333045
153A	Stationary Seat (Hardened Steel)	2	333061
153B	Seal Face (Carbon)	2	333053
153C	Jacket Assembly	2	333057
153D	O-Ring - Stationary (Buna-N)	2	711916
153E	O-Ring - Rotating (Buna-N)	2	711915

\* Included in Pump Repair Kit.

MECHANICAL SEAL - OPTIONAL (MAPP GAS)

REF. NO.	PART NAME	PARTS PER PUMP	PART NO.
153	Mechanical Seal Assembly	2	333044
153A	Stationary Seat (Hardened Steel)	2	333061
153B	Seal Face (Carbon)	2	333053
153C	Jacket Assembly	2	333057
153D	O-Ring - Stationary (Viton)	2	711908
153E	O-Ring - Rotating (Viton)	2	701971

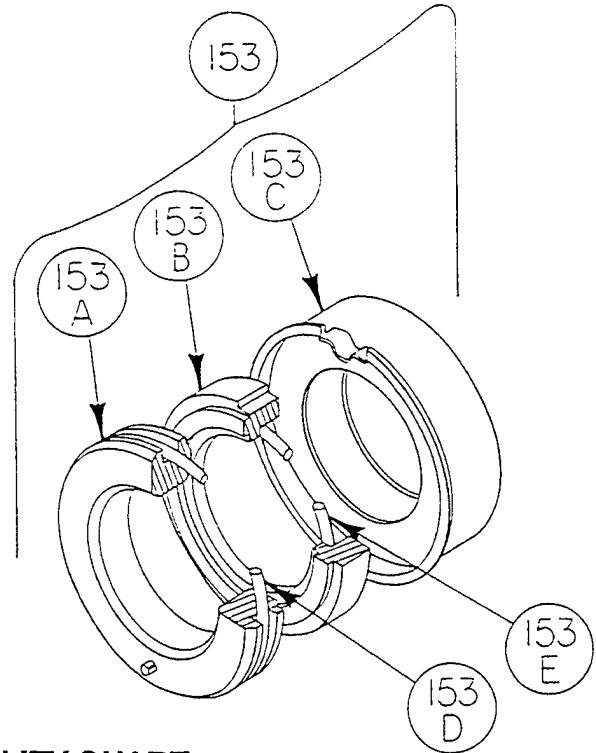

INTERCHANGEABILITY CHART

PART NAME	LG1¼A, LG1¼C		LGL1¼	
	Interchangeability status w/LGL1¼		Interchangeability status w/LG1¼A, LG1¼C	
	PART NO.	REF.	PART NO.	REF.
Cylinder	023075	b	N/A	-
Casing	N/A	-	013075	-
Liner	N/A	-	183004	-
Rotor & Shaft	263075	c	263076 262300	d
Lockcollar	703075	c	N/A	-
Bearing Locknut	N/A	-	903534	-
Bearing Lockwasher	N/A	-	903533	-
Bearing Cover (Inboard)	043075	c	043070	a
Bearing Cover (Outboard)	043077	c	043071	a

PART NAME	LG1½A, LG1½C		LGL1½	
	Interchangeability status w/LGL1½		Interchangeability status w/LG1½A, LG1½C	
	PART NO.	REF.	PART NO.	REF.
Cylinder	023375	b	N/A	-
Casing	N/A	-	013376	-
Liner	N/A	-	183301	-
Rotor & Shaft	263075	c	263076 262300	d
Lockcollar	703075	c	N/A	-
Bearing Locknut	N/A	-	903534	-
Bearing Lockwasher	N/A	-	903533	-
Bearing Cover (Inboard)	043075	c	043070	a
Bearing Cover (Outboard)	043077	c	043071	a

Reference:

- a = Interchangeable
- b = Not Interchangeable; May be replaced by Casing & Liner
- c = Not Interchangeable
- d = Interchangeable but requires new bearing covers (P/N 043070 & P/N 043071), and bearing lockwashers (P/N 903533)



# BLACKMER LIQUEFIED GAS PUMPS FOR LP-GAS AND NH<sub>3</sub> SERVICE

INSTALLATION, OPERATION AND MAINTENANCE INSTRUCTIONS

960417  
INSTRUCTIONS NO. 585/E

Section	500
Effective	April 1989
Replaces	January 1983

## MODELS: LGL2E, TLGLD2E, LGL3E, TLGLD3E

### GENERAL INFORMATION

#### SAFETY RULES

It is recommended that NFPA Pamphlet 58 be consulted for Safety Rules. Consult local and State regulations also.

#### WARNING

**THIS PRODUCT MUST ONLY BE INSTALLED IN SYSTEMS WHICH HAVE BEEN DESIGNED BY THOSE QUALIFIED TO ENGINEER SUCH SYSTEMS. THE SYSTEM MUST BE IN ACCORDANCE WITH ALL APPLICABLE REGULATIONS AND SAFETY CODES AND WARN OF ANY HAZARDS UNIQUE TO THE PARTICULAR SYSTEM.**

#### WARNING DANGER

**DO NOT ATTEMPT TO OPEN THE PUMP UNTIL YOU HAVE BLEDED OFF THE PRESSURE. ON SYSTEMS WITH METERS, THE DIFFERENTIAL VALVE WILL KEEP LIQUID UNDER PRESSURE IN THE PUMP, METER AND PIPING EVEN WHEN THE HOSE IS EMPTIED.**

#### PUMP DATA

	Size 2	Size 3
Nominal Capacity (GPM) (640 RPM—50 PSI) at Ambient Temperature of:		
80° F.	64	137
32° F.	51	107
Maximum Differential Pressure (PSI) (330 RPM to 640 RPM)	150	150
Maximum Pump Speed (RPM)	980	980
Maximum Differential Pressure (PSI) (at 980 RPM)	60	60
Pump Weight (LBS.)	85	160
Maximum Temperature (° F.)	240	240
Torque Required (FT-LB.) (at 100 PSI)	48	89
Model Designations:		
For Motor Drive	LGL2E	LGL3E
For Truck Mounting	TLGLD2E	TLGLD3E
These pumps are listed by Underwriters' Laboratories, Inc. for liquefied-petroleum gas and NH <sub>3</sub> .		

## INSTALLATION AND OPERATION—MOTOR DRIVEN PUMPS

#### LOCATION

Locate the pump as near the source of supply as possible to reduce pipe friction. A good foundation reduces vibration and noise and improves the pump performance. On permanent installations, it is recommended that the pumping units be securely bolted to a concrete foundation.

When new pump foundations are to be cast in concrete, it is suggested that anchor bolts of the type shown in Fig. 1 be set into the concrete.

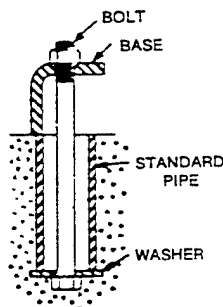

Fig. 1

should not be used for recirculation. A separate bypass valve is required by Underwriters' Laboratories, Inc. piped from the pump discharge system back to the supply tank. The setting on the separate bypass valve should be at least 25 psi less than the relief valve setting. Do not pipe the bypass valve back to the intake line. The valve and piping should be of adequate size to accommodate the full flow from the pump when the discharge line is closed.

The Blackmer Model BV2 separate bypass valve can be mounted as shown in Fig. 2 for bulk plant installation.

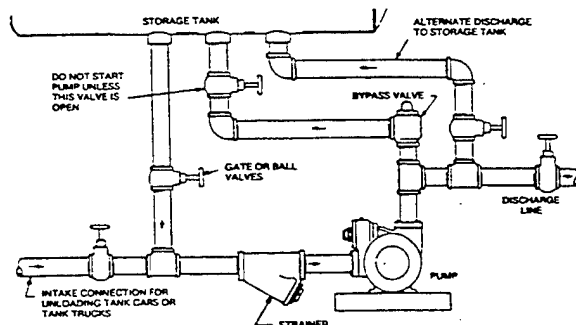

Fig. 2

#### RELIEF VALVE & BYPASS VALVE

The built-in spring loaded relief valve is to prevent damage to the pump or pumping system from excess pressure and

## STRAINER

The pump should be protected from foreign matter by the installation of a strainer in the intake line. A 40 mesh screen is recommended. It will prevent .010" and larger pieces of weld splatter, slag, etc. from entering the pump.

## PIPING

Many pump systems deliver at a rate below the designated capacity of the pump because the system was improperly piped. Restrictions in the pipe line should be avoided, such as elbows, sharp bends, globe valves, certain restricted type plug valves and undersize strainers. Use pipe of adequate size and strength that has been thoroughly flushed before connecting to the pump. Less restrictive gate or ball valves should also be used. Flexible connectors used near the pump will compensate for expansion, contraction and will provide a more vibration free operation.

Unions and valves in the piping near the pump will facilitate maintenance. On the intake side, locate the nearest fitting at least six inches from the pump to permit the removal of the relief valve cover.

## CAUTION

### PUMP WITH WELDED CONNECTIONS

**THE PUMP CONTAINS THREE NON-METALLIC "O" RING SEALS THAT WILL BE DAMAGED IF WELDING IS DONE WITH THESE "O" RINGS INSTALLED.**

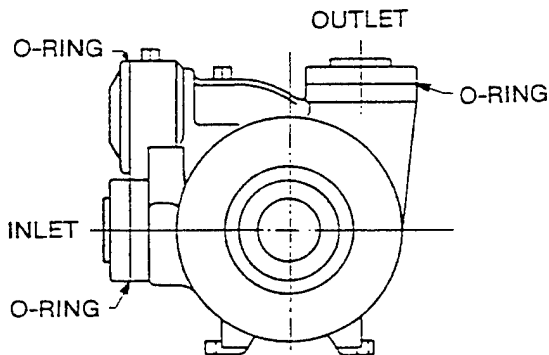

Fig. 3

Remove the "O" rings under the inlet flange, outlet flange and the relief valve cover then reinstall the inlet and outlet flanges.

Weld piping to inlet and outlet flanges and reinstall the three "O" rings.

When the unit is first started, rotation should be checked with the direction arrow on the pump. The discharge pressure should be compared to the supply pressure with a closed discharge. If the differential is over 100 psi, the separate bypass valve setting should be reduced.

Whenever possible, keep liquefied gas systems full of liquid, even when idle. This will keep the "O" rings from changing shape, shrinking or super cooling. Evaporation of liquefied gas leaves an abrasive powder on the surface which can cause wear to the pump, seals, meter, etc. If the system does not function properly, refer to the section on "Pump Troubles and Their Cures."

Use a vapor return line if possible. This will speed up delivery since a vapor line prevents back pressure from building up at the receiving tank, and a vacuum from forming in the supply tank. In laying out the system, read the section on "Pump Troubles" for suggested ways to eliminate difficulties before they develop.

## ALIGNMENT

Where flexible couplings are used, the coupling cover should be removed and a straight edge laid across the two hubs of the coupling as shown in Fig. 4. The maximum offset should be less than .015".

With a feeler gage or piece of flat steel of proper thickness, check the space between the two coupling halves. Insert a gage at a point on the coupling, and at 90° increments about the coupling. The space should not vary more than .020". Misalignment is not desirable. If it does exist, it must not exceed the above limits.

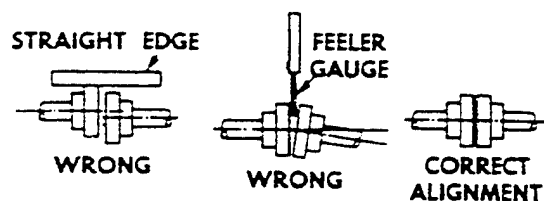

Fig. 4

The installation should be checked before being put into operation. Install a pressure gage in the gage hole nearest the discharge port provided on the pump casing before starting. Check all valves. The valves in the bypass return line must be open. After the pump is started, check the direction of the arrow on the pump head.

## OPERATIONAL CHECK

The relief valve and separate bypass valve setting should be checked as described under Steps 8, 9 and 10 of Truck pump "Operation Check." The separate bypass valve on motor driven units is frequently set to protect the motor. If the pump is not delivering the expected flow rate, the separate bypass valve may be set too low and thus remain partially open. Remember that relief valves normally begin to bypass about 5 to 15 psi below their setting.

# MAINTENANCE

**MAINTENANCE AND TROUBLE SHOOTING MUST BE DONE BY AN INDIVIDUAL EXPERIENCED WITH PUMP MAINTENANCE AND THE TYPE OF SYSTEM INVOLVED.**

## LUBRICATION

Pump bearings should be lubricated every three months.

Use Standard Oil - Amolith All Weather  
(must be paraffinic base) Grease.

Apply grease with a hand pressure gun until it appears at the grease relief fitting.

It is normal for some grease to escape from the tell-tale holes under the bearing covers for a short period after lubrication. If this condition persists, the head must be removed and the mechanical seal replaced.

On motor-driven units using a gear reducer, the oil in the gear case should be maintained to the oil level plug hole, and changed every 6 months.

## DISASSEMBLY

Before work is started on a pump it must be drained and the gas pressure relieved.

The size 2 pumps have dirt shields on the shafts; the double-end shaft models have one on each shaft. These shields will slide off the shaft with the bearing cover after removing the bearing cover capscrews.

Bearings are located by collars and serve as thrust bearings to position the rotor in the casing. It is necessary to remove the locknut and lockwasher, from each end of the rotor shaft, before each head can be removed. Remove the bearing cover, wipe off the excess grease, and locate the lockwasher tang that is staked into one of the locknut slots. Using a small blade screwdriver, pry up the staked lockwasher tang and remove the locknut. Remove the head capscrews and use two (2) large screwdrivers to pry the head loose from the casing around the head O.D. Slide the head assembly off the rotor shaft and be care not to drop the bearing.

The stationary seat, of the seal and its "O" ring, will come off the shaft as part of the head assembly. To remove the stationary seat, remove the bearing and use a screwdriver to push the stationary seat out of its cavity. The seal face and seal jacket may require a light pry to be slid off the shaft. Wipe the shaft and inspect for pits under the seal face "O" ring. If the seal has been leaking, it is advisable to replace the entire seal, including the stationary seat and its "O" ring. It is important to keep all parts of the seal clean.

With a pick or small screwdriver, slide out the three (3) uppermost vanes noting which side the slots are on. Inspect the

and tears. Replace these vanes and rotate the rotor shaft 180 degrees. Remove and inspect the top three (3) vanes. If vanes are damaged, it is advisable to remove the rotor and inspect the liner.

Remove the remaining head and hold the bottom vanes in the vane slot to prevent the push rods from jamming the rotor while it is being removed. Using a hard wood or brass drift and hammer, tap the liner around its outer edge to drive it out of the casing.

## ASSEMBLY

Before assembling, clean each part thoroughly. Wash out bearing and seal cavities and recessed areas in the casing. Remove any burrs from a new liner with a file.

Install the liner with the "slots" towards the casing intake port and the "hole pattern" towards the discharge port. Align the key slot in both casing and liner and install the key. If the liner is installed backwards it will restrict the port openings, cause noise and loss of capacity.

The double ended rotor shaft, of the TLGL pumps, allows these pumps to be driven from either end. The single ended rotor shaft, in LGL pumps, may be assembled for either left-hand (L.H.) or right-hand (R.H.) rotation. To determine rotation, use the following:

If the intake port is to the left, and the drive end of the shaft is towards the observer, the pump rotation is left-hand (L.H.).

If the intake port is to the right, and the drive end of the shaft is towards the observer, the pump rotation is right-hand (R.H.).

Install three (3) of the vanes in the bottom slots of the rotor with the rounded edges out and the grooves facing in the direction the rotor is to rotate. See Fig. 6. Keep the vanes in the rotor slots with a cupped hand under the rotor. Install the three (3) push rods and slide the rotor into the liner. Referring to Fig. 6, insert the remaining three (3) vanes in the top rotor slots and put a light coating of oil on both ends of the rotor shaft between the threads and the rotor.

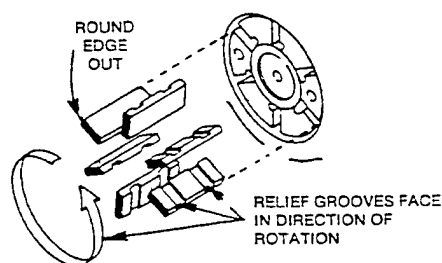

Install a disc, against the liner, with the seal cavity outward and the disc hole radially positioned as shown in Fig. 7. Slide the seal jacket assembly over the shaft, with the drive tangs towards the rotor. Rotate the seal jacket assembly to get its tangs through the disc and engaged in the two (2) drive holes in the rotor. Insert the rotating "O" ring into the seal face and slide this subassembly, with polished mating face outward, over the shaft to the seal jacket assembly. Rotate the seal face to align the drive notches. Wipe any dirt, oil or grease off the mating surface of the seal face with a clean tissue (not a shop cloth).

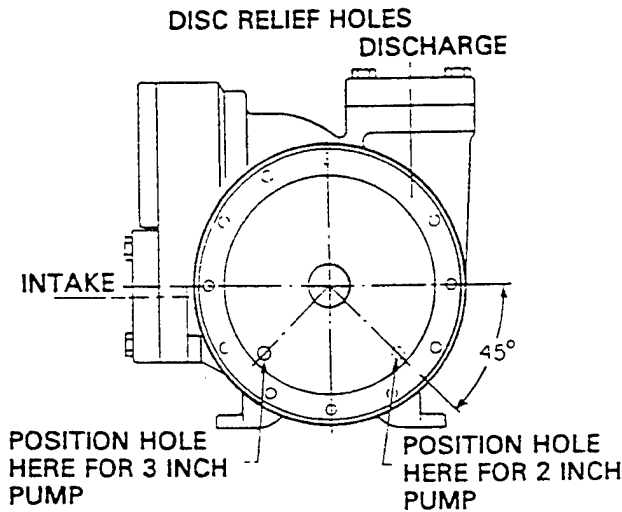

Fig. 7

With the head resting on its bearing boss, put a light coating of oil on the stationary seat cavity. Install the "O" ring in the groove around O.D. of the stationary seat. A pin, projecting from the back surface of the stationary seat, must be radially positioned to align with a notch at the bottom of the stationary seat cavity. Push the stationary seat into the cavity and make certain it is down. Wipe the mating face, of the stationary seat with tissue to remove any dirt, oil or grease.

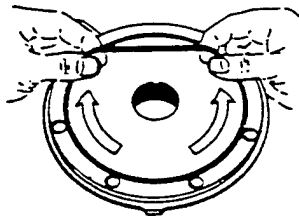

Fig. 8

The head "O" ring should be replaced if it is swollen, nicked, or cut. It is normally smaller in diameter than the "O" ring groove. To install, lay the ring flat on the head and start on one side of the groove. Slide thumbs over the "O" ring in opposite directions, stretching ahead with the fingers as shown in Fig. 8. If the "O" ring is rolled into the groove, it will roll right out.

Install the head assembly over the rotor shaft being careful to avoid any contact between the end of the rotor shaft and the mating face of the stationary seat. Rotate the head so that the drain hole, at the rear of the bearing cavity, is down when the pump is mounted for operation. Hold the head against the casing and install four (4) head capscrews, 90° apart. Snug up the four (4) capscrews but do not tighten. Install the bearing with the seal side in and the balls visible. Carefully tap the bearing outer race to seat the bearing in its cavity. Use the same procedure to install the second disc, seal assembly, head and bearing.

Install lockwashers and locknuts on both ends of the rotor shaft and tighten both locknuts very tight. Tighten the four (4) head capscrews holding each head, and loosen both bearing locknuts. Rotate the rotor shaft, by hand, to determine if any binding or tight spots exist. Any of these conditions may be corrected by loosening the four (4) capscrews, on one head, approximately one-half turn and tapping that head up or down, with a lead hammer. When the correct position is found, tighten the four (4) loosened capscrews and recheck for binding. Install and tighten all of the remaining head capscrews.

Tighten one bearing locknut until increased drag is noted, while turning the rotor shaft. Then tighten the other locknut until the increased drag disappears. Locate the closest lockwasher tang to a locknut slot, align these two and stake the tang into the slot. Repeat this operation with the second locknut then install gaskets and bearing covers on both ends. The bearing covers should be installed with the grease fittings up on stationary installations and down on mobile installations.

#### TO REVERSE PUMP ROTATION

Pump rotation, of LGL pumps, may be reversed by changing the side that the drive end of the shaft projects from the pump. Bearing covers, locknuts and one head must be removed to reverse the shaft. Previously covered "Disassembly and Assembly" Instructions apply.

# PUMP TROUBLES AND THEIR CURES

## VANE WEAR

Vane wear and push rod penetration are usually caused by excessive vapors entering the pump (called cavitation) or by abrasives in the liquid. Cavitation causes the vanes to "bounce" violently and sometimes is accompanied by noise and vibration.

Intake piping should be at least 2" on the LGL2 and TLGLD2 and at least 3" on the LGL3 and TLGLD3. For longer runs the next size larger piping should be used. Cavitation can be caused by circulation of liquid through the built-in relief valve on the pump, or through the separate bypass valve improperly piped back into the intake pipe. This can also happen if the pump valve operates at a lower differential pressure than the separate bypass valve, even though the separate bypass valve discharges into the supply tank. Check the setting of the separate bypass valve. Cavitation is also caused by restricted intake piping, small or defective excess flow valve, plugged or too fine a strainer basket, and the use of globe valves instead of ball-type or gate-type valves.

All the above conditions are aggravated if the pump is running too fast and is trying to deliver liquid faster than the piping can handle it.

One or more vanes installed backwards will cause noise and loss of capacity.

## DAMAGED PUMP PARTS

Worn or scored discs can be caused by improper adjustment of the locknuts.

Corrosion of pump parts can be caused by calcium chloride brine carried over from dehydrators. Corrosion may damage internal parts and weaken the entire system. Corrective action should be taken immediately to eliminate the cause of corrosion.

## LEAKAGE

Mechanical seals can be damaged and begin leaking from using the wrong grease, greasing with a high pressure gun, dirt or abrasive particles entering between the seal faces, cut or otherwise damaged "O" rings.

Leakage may appear at the drain holes under the bearing housing on the pump head. If leakage becomes excessive the entire mechanical seal assembly should be replaced. Leakage between the heads and pump casing is caused by a cut, nicked or damaged head "O" ring and the "O" ring must be replaced.

## ROTOR AND DISC WEAR

Worn universal joints or a slip-joint that does not slip under load are the two most common causes for excessive end thrust on the pump shaft. This will cause the rotor to wear into the pump discs.

The most effective slip-joint is a well lubricated close fitting splined slip-joint. These commercially manufactured slip-joints will move axially under a high torque (rotating load). Worn, dry or dirty slip-joints especially the square "home-made" type will slip axially when the pump running, but when under load with the pump running the slip-joint becomes rigid. This can result in severe end thrust and wear to the pump.

## NOISE AND VIBRATION

The most frequent cause is recirculation through the pump relief valve, caused by malfunction of the separate bypass or high bypass setting.

Another cause is excessive cavitation from a restricted intake, dirty strainer, small excess flow valve, too long or too small intake pipe.

Other possible causes—one or more vanes installed backwards, universal joints out of phase.

## LOSS OF CAPACITY

The most probable causes are: restricted valve in pipe line; restricted excess-flow valve at tank outlet; cavitation; pump rotating backward; worn vane, disc, liner or rotor; pump located too far from storage tank (see paragraph on Location under "Motor Driven Pumps").

Cavitation and vapor binding may be caused by circulation of liquid through the relief valve. This will happen if the separate relief valve is set too high, is too small, or if the piping on the valve is too small. It can also be caused by overheating the pump or piping from hot sunshine or being located near a hot exhaust pipe.

If the excess-flow valve closes, it is an indication of trying to deliver too fast. The pump speed should be reduced.

Capacity without a vapor return line will be less than when a vapor return line is used.

Fisher Controls

Instruction Manual

**Type 98L and Type 98H Back Pressure and Relief Valves****FISHER®**

August 1993

Form 1570

**WARNING**

Fisher relief valves must be installed, operated and maintained in accordance with federal, state, and local codes, rules and regulations, and Fisher instructions.

If the spring case develops a leak or if the outlet continually vents gas, service to the unit may be required. Failure to correct trouble could result in a hazardous condition. Only a qualified person must install or service the unit.

**Introduction**

Type 98L and Type 98H (see figure 1) are self-operated, spring-loaded back pressure or relief valves. Typical applications include use in wash tanks, small heaters, fuel and oil lines, air supply systems, test fixtures, and sterilizers. Relief pressure ranges are 2 to 38 psig (0.14 to 2.6 bar), in four ranges, for the Type 98L and 15 to 200 psig (1.03 to 13.8 bar), in eight ranges, for the Type 98H. Type 98L body sizes are 1/4, 1/2, 3/4 and 1-inch. Type 98H body sizes are 1/4, 1/2, 3/4, 1, 1-1/2 and 2-inch.

**Specifications**

Specifications for the Type 98L and 98H backpressure and relief valves are given in table 1.

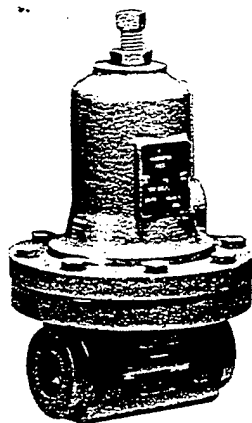

W6155

TYPE 98H

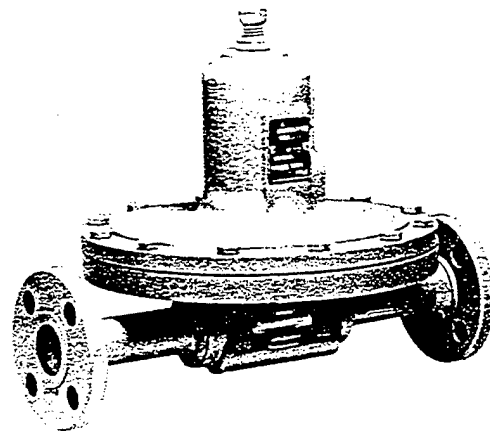

W6156

TYPE 98L

Figure 1. Type 98L & 98H Back Pressure and Relief Valves

# Types 98L and 98H

Table 1. Specifications

Available Constructions		Allowable Temperature Ranges <sup>(5)</sup>	
<p><b>Type 98L:</b> Self-operated with standard adjusting screw. Relief pressure ranges are 2 to 38 psig (0.14 to 2.6 bar).</p> <p><b>Type 98H:</b> Self-operated with standard adjusting screw. Relief pressure ranges are 15 to 200 psig (1.03 to 13.8 bar).</p>		<p><b>Nitrile Parts:</b> - 20 to 200°F (- 29 to 93°C)</p> <p><b>Neoprene Parts:</b> - 40 to 150°F (- 40 to 66°C)</p> <p><b>Fluoroelastomer Parts:</b> 0 to 300°F (- 18 to 149°C)</p>	
End Connection Style		Metal Diaphragm and Seat	
<p>NPT screwed, socket weld, or ANSI flanged-14 inches face to face (DIN flanged-356mm face to face)</p>		<p><b>Cast Iron Body and Spring Case:</b> - 40 to 406°F (- 40 to 208°C)</p> <p><b>Steel Body and Spring Case:</b> - 20 to 450°F (- 29 to 232°C)</p> <p><b>Stainless Steel Body and Spring Case:</b> - 40 to 450°F (- 40 to 232°C)</p>	
Body Sizes		Approximate Weight, lb (kg)	
<p>■ 1/4, ■ 1/2, ■ 3/4, ■ 1, ■ 1-1/2, ■ 2</p>		<p><b>Type 98H</b>                      1/4-inch Body: 7 (3.18)                      1/2-inch Body: 7 (3.18)                      3/4-inch Body: 16 (7.26)                      1-inch Body: 16 (7.26)                      1-1/2-inch Body: 55 (25)                      2-inch Body: 55 (25)</p> <p><b>Type 98L</b>                      1/4-inch Body: 6 (2.80)                      1/2-inch Body: 13 (5.90)                      3/4-inch Body: 30 (13.6)                      1-inch Body: 30 (13.6)</p>	
Maximum Inlet Pressures, Psig <sup>(1,5)</sup> (Set Pressure Plus Buildup)			
TYPE NUMBER	STEEL (WCB) OR STAINLESS STEEL BODY/ ALL TRIMS TO 150°F <sup>(2)</sup> (66°C)	CAST IRON BODY	
		All Trims to 150°F <sup>(3)</sup> (66°C)	Metal Trims <sup>(4)</sup> To 315°F (66°C)    To 406°F (208°C)
98L	125 (52)	60 (16)	60 (16)    60 (16)
98H	300 (149)	300 (149)	300 (149)    250 (121)
Relief Pressure Ranges			
See table 2			
<p>1. Relief pressure setting plus maximum allowable buildup over setting.                      2. Or fluoroelastomer trims to 300°F (149°C) or metal trims to 450°F (232°C).                      3. Or fluoroelastomer trims to 300°F (149°C).                      4. Interpolate for intermediate pressure ratings.                      5. The pressure/temperature limits in this bulletin and any applicable standard limitation should not be exceeded.</p>			

Table 2. Relief Pressure Ranges

BODY SIZE, INCHES	98L RANGE		98H RANGE		COLOR CODE	PART NUMBER
	Psi	Bar	Psi	Bar		
1/4	2 to 17	0.1 to 1.2	15 to 35	1.0 to 2.4	Yellow	1E392527022
	6 to 14	0.4 to 1.0	25 to 75	1.7 to 5.2	Green	1E392627012
	12 to 25	0.8 to 1.7	70 to 140	4.8 to 9.7	Red	1E392727142
	20 to 38	1.4 to 2.6	130 to 200	9.0 to 13.8	Blue	1L346127142
1/2	2 to 17	0.1 to 1.2	15 to 35	1.0 to 2.4	Yellow	1E395627022
	6 to 14	0.4 to 1.0	25 to 75	1.7 to 5.2	Green	1D745527142
	12 to 25	0.8 to 1.7	70 to 140	4.8 to 9.7	Red	1D395727192
	20 to 38	1.4 to 2.6	130 to 200	9.0 to 13.8	Blue	1L380027142
3/4 & 1	2 to 17	0.1 to 1.2	15 to 35	1.0 to 2.4	Yellow	1E398927022
	6 to 14	0.4 to 1.0	25 to 75	1.7 to 5.2	Green	1E399027142
	12 to 25	0.8 to 1.7	70 to 140	4.8 to 9.7	Red	1D399127162
	20 to 38	1.4 to 2.6	130 to 200	9.0 to 13.8	Blue	1L380127232
1-1/2 & 2	---	---	5 to 35	0.3 to 2.4	Dark Gray	1E792327092
	---	---	20 to 65	1.4 to 4.5	Light Blue	1E795327082
	---	---	50 to 100	3.4 to 6.9	Light Gray	1E795427082
	---	---	80 to 170	5.6 to 11.7	Black	1P788827082
<p>1. All springs may be backed off to 0 psig (bar). However, highest capacities and best performances are obtained by using these springs in their recommended ranges. Psi (bar) rather than psig (bar) are used for differential relief constructions.</p>						

## Installation

Unbox and inspect the valve. Remove pipe scale and other foreign material from the connecting pipeline. Apply a suitable pipe compound to the male threads. The relief valve can be installed in any position as long as the flow is in the direction indicated by the arrow cast on the body.

Maximum operating temperatures for the Type 98L and 98H relief valves are as follows:

Elastomer diaphragm or seat: 150°F (66°C)

Metal diaphragm and seat: 406°F (208°C) with cast iron body and spring case or 450°F (232°C) with steel or stainless steel body and spring case

## Vents

### WARNING

If the process fluid is hazardous, install remote vent lines to carry fluid to a safe area.

If remote venting is necessary, an optional tapped vent in the spring case is available. Install remote vent lines in the spring case and outlet openings. The vent lines must have the largest practical diameter and be as short as possible with a minimum number of bends or elbows.

## Overpressure

### WARNING

Overpressuring any portion of this equipment may result in equipment damage, leaks in the relief valve, or personal injury due to bursting of pressure-containing parts. The system should be inspected after any overpressure condition.

Relief or back pressure ranges are from 2 to 200 psig (0.14 to 13.8 bar). The individual spring range of your relief valve is stamped on the nameplate.

Maximum inlet pressures depend upon body materials and temperatures. See table 1 for the maximum inlet pressure of the valve. The valve should be inspected for damage after any overpressure condition.

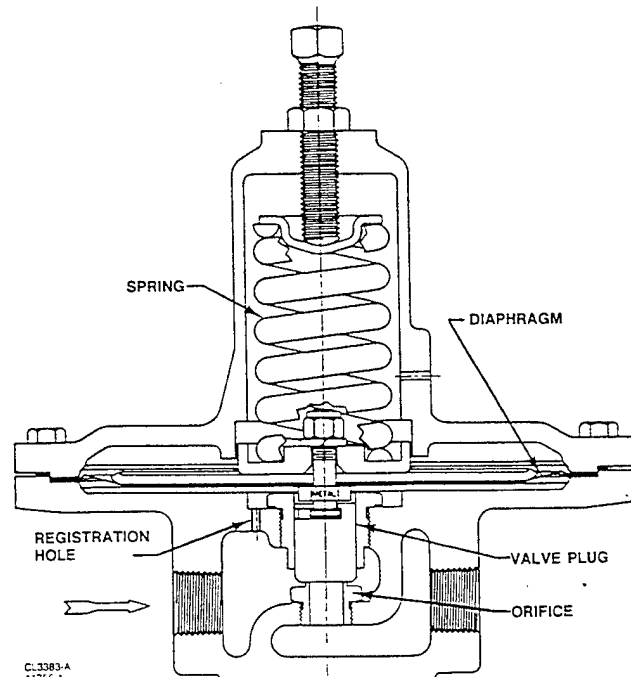

Figure 2. Type 98L Relief Valve Operational Schematic

## Adjustment

Each unit is factory set for the pressure specified on your order. The allowable spring range is stamped on the nameplate. If a pressure setting beyond the indicated range is required, substitute the appropriate spring. Be sure to label the valve to indicate the new pressure range.

Always use a pressure gauge to monitor pressure when making adjustments.

Loosen the locknut (key 17). To increase the setting, turn the adjusting screw (key 15) clockwise. Turn the adjusting screw counterclockwise to decrease the setting. Tighten the locknut.

## Principle Of Operation

Relief or back pressure valves respond to changes in upstream pressure. Pressure changes register under the diaphragm (see figure 2) through a registration hole in the valve body. When the pressure increases beyond the spring setting, the diaphragm pressure overcomes the spring compression. This causes the valve plug to move away from the orifice. The flow line through the valve is open and excess pressure is vented. When upstream pressure drops back to normal, the valve resumes its closed position.

**Maintenance**

**WARNING**

To avoid personal injury and equipment damage, isolate the valve from all pressure. Cautiously release pressure from the valve before attempting disassembly.

Due to normal wear and damage that may occur from external sources, relief valve parts such as the O-rings, gaskets, diaphragm, orifice, and valve plug should be inspected periodically and replaced as necessary. The frequency of inspection and replacement depends upon the severity of service conditions or the requirements of state and federal laws.

Instructions are given below for disassembly of the Type 98L and 98H back pressure relief valves. These valves do not have to be removed from the pipeline to inspect internal parts. Suitable lubricants are indicated on the assembly drawings. Apply the lubricants as the relief valve is being reassembled. Refer to figures 3 and 4 while servicing the relief valve.

1. Relieve the spring tension by loosening the locknut (key 17) and turning the adjusting screw (key 15) counterclockwise. Remove the cap screws (key 16). Lift off the spring case (key 2), spring (key 11), and upper spring seat (key 9).
2. Lift out the diaphragm unit which includes the pusher post (key 6), lower spring seat (key 8), diaphragm head (key 25, Type 98L), diaphragm (key 12), washer (key 7), and valve plug (key 4). (There will be two diaphragms if the diaphragm material is metal or fluoroelastomer.)
3. Check the orifice (key 3). If it needs replacing or repairing, unscrew the valve plug guide (key 5) and then the orifice. The valve plug can be removed by sliding it off of the pusher post.

**Note**

If damage to elastomer or metal seating surfaces is severe, replace the orifice and valve plug O-ring with new parts. However, by following the lapping procedure below, it is possible to repair metal seating surfaces if they are only slightly worn or scratched.

4. Lapping procedure:

- a. Place a small amount of 500-grit silicon carbide or aluminum oxide lapping compound on a flat surface such as a piece of heavy plate glass.

Table 3. Torque Specifications

Body Size, Inches	Spring Case Ft-Lbs	Orifice Ft-Lbs
1/4	4.5 - 5.0	8 - 12
1/2	10 - 13	29 - 35
3/4 - 1	24 - 30	33 - 42
1-1/2 - 2	40 - 50	140 - 170

b. Take the valve plug or orifice and move it in a figure 8 motion on the lapping compound. Do not allow the part to tip or rock since this would round the corners.

c. Repeat step b for each part, using an 800-grit or 1000-grit silicon carbide or aluminum oxide lapping compound.

d. Wash away all traces of the lapping compound. To help prevent scratching the seating surfaces, a light coat of oil may be applied before returning the valve plug and orifice to the body. See table 3 for torque specifications.

5. Return the orifice and valve plug guide to the body.
6. To replace the valve plug O-ring (key 22), remove the screw (key 24) and O-ring retainer (key 21) from the plug. Remove and replace the O-ring.
7. Separate the remainder of the diaphragm unit parts. Take the locknut (key 26) off of the pusher post. Slide off the washer (key 23), lower spring seat, diaphragm head (Type 98L), diaphragm, washer (key 7), and gasket (key 10).
8. Slip the plug onto the pusher post.

**Note**

If a metal diaphragm is to be replaced by a elastomer diaphragm or a elastomer diaphragm by a metal diaphragm, a new pusher post is required. Each diaphragm material requires a different length pusher post.

9. Replace the diaphragm gasket (key 19) if necessary.
10. Slip gasket, washer, diaphragm, diaphragm head, lower spring seat, and washer back onto the pusher post. Screw on the locknut and return the unit to the body.
11. Set the spring in the lower spring seat and place the upper spring seat on the spring.
12. Put the spring case over the spring and onto the body. Tighten the cap screws finger tight only.

13. To ensure proper slack in the diaphragm, apply some spring compression by turning the adjusting screw clockwise. Finish tightening the cap screws.

## Parts Ordering

When corresponding with your Fisher sales office or sales representative about this equipment, be sure to include the type number and other information stamped on the nameplate.

When ordering replacement parts, reference the key number of each needed part and specify the eleven-character part number as found in the following parts list.

## Parts List

Key	Description	Part Number
	Note	
	In this parts list, parts marked NACE are intended for corrosion-resistant service as detailed in the National Association of Corrosion Engineers (NACE) standard MR0175-92.	
	Parts kit (included are keys 3, 4, 10, 12, 19, 21, 22 and 24). Also included for 98H only is key 14.	
	Elastomer Trim	
	1/4-inch body	R98H X000012
	1/2-inch body	R98H X000022
	3/4 and 1-inch body	R98H X000032
	1-1/2 and 2-inch body	
	Type 98H only	R98H X000072
	Metal Trim	
	1/4-inch body	R98H X000042
	1/2-inch body	R98H X000052
	3/4 and 1-inch body	R98H X000062
	1-1/2 and 2-inch body	
	Type 98H only	R98H X000082
1	Body	See following table
2	Spring Case	
	Type 98H	
	Cast iron	
	1/4-inch body	2E3912 19012
	1/2-inch body	2J4962 19012
	3/4 and 1-inch bodies	3E3978 19012
	1-1/2 and 2-inch bodies	4P7840 19012
	Steel	
	1/4-inch body	2J1275 22012
	1/2-inch body	2L4163 22012
	3/4 and 1-inch bodies	3E4087 22012
	1-1/2 and 2-inch bodies	3P7904 22012

Key	Description	Part Number
2	Spring Case (Continued)	
	Type 98L	
	Cast iron	
	1/4-inch body	2E3913 19012
	1/2-inch body	3J4963 19012
	3/4 and 1-inch bodies	4E3979 19012
	Steel	
	1/4-inch body	2J1279 22012
	1/2-inch body	3L4161 22012
	3/4 and 1-inch bodies	4E5929 22012
3*	Orifice	See following table
4*	Valve Plug	See following table
5	Valve Plug Guide	
	416 stainless steel	
	1/4-inch body	1L3458 35132
	1/2-inch bodies	1L3416 35132
	3/4 and 1-inch bodies	1L3429 35132
	1-1/2 and 2-inch bodies	1P7885 35132
	316 stainless steel	
	1/4-inch body (NACE)	1L3458 35072
	1/2-inch body (NACE)	1L3416 35072
	3/4 and 1-inch bodies (NACE)	1L3429 35072
	1-1/2 and 2-inch bodies (NACE)	
	Type 98H only	1P7885 35072
6	Pusher Post	See following table
7	Washer (elastomer diaphragm only)	
	416 stainless steel trim	
	1/4-inch body	1L3447 36012
	1/2-inch body	1L3398 36012
	3/4 and 1-inch bodies	1L3428 36012
	316 stainless steel trim	
	1/4-inch body, std	1L3447 36142
	(NACE)	1L3447 X0012
	1/2-inch body, std	1L3398 35072
	(NACE)	1L3398 40032
	3/4 and 1-inch bodies, std.	1L3428 36142
	(NACE)	1L3428 X0022
8	Lower Spring Seat	
	1/4-inch body, aluminum	1L3446 09012
	1/2-inch body, aluminum	1L3397 08012
	3/4 and 1-inch bodies, aluminum	1L3427 08012
	1-1/2 and 2-inch bodies	
	Type 98H only, steel zinc plated	1P7877 24152
9	Upper Spring Seat, steel pl	
	1/4-inch body	1B7985 25062
	1/2-inch body	1D6671 25072
	3/4 and 1-inch bodies	1E3987 25072
	1-1/2 and 2-inch bodies	
	Type 98H only	1P7876 24092
10*	Gasket, composition	
	(2 req'd for metal diaphragm)	
	1/4-inch body	1L3448 04022
	1/2-inch body	1L3411 04022
	3/4 and 1-inch bodies	1L3434 04022
	1-1/2 and 2-inch bodies (metal diaphragm only) (2 req'd)	
	Type 98H only	1P7880 04022
11	Relief Valve Spring	See following table
12*	Diaphragm	See following table
13	Nameplate, aluminum	
	(not shown)	11A5494 X0A2
14*	O-Ring, Type 98H only	
	1-1/2 and 2-inch bodies, elastomer seat only	
	Nitrile	1C7822 06992
	Fluoroelastomer	1K7561 06382
	Fluoroelastomer (NACE)	1K7561 35072

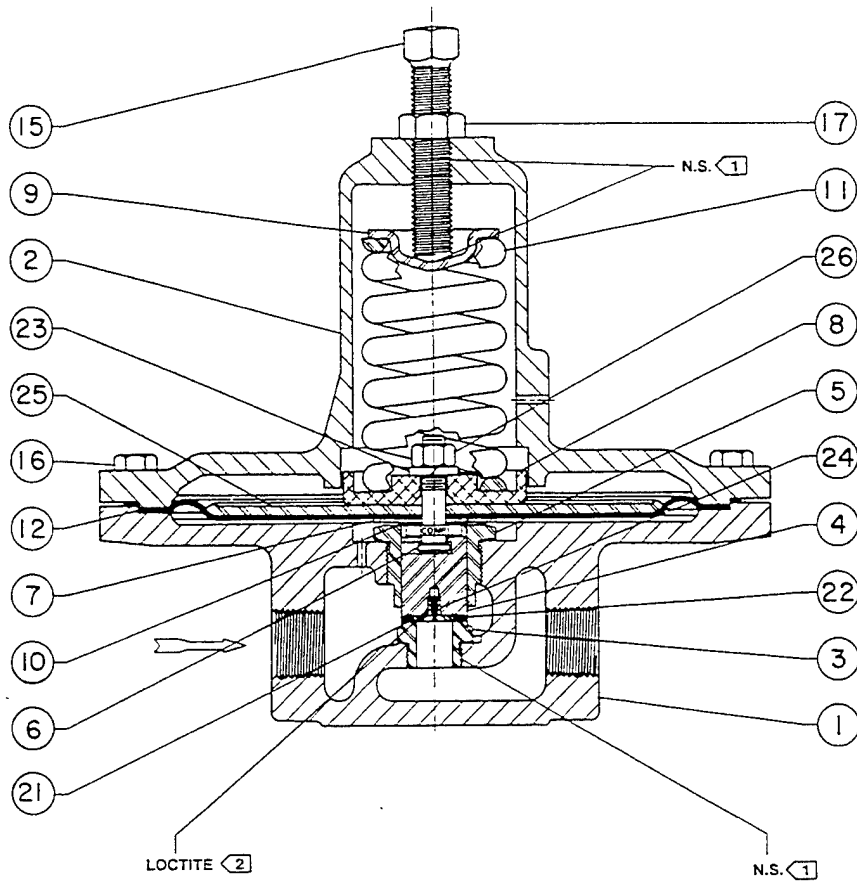

NOTE:  
 PARTS NOT SHOWN 13, 18, & 20  
 1 NEVER-SEEZ MARK OWNED BY COMPOUND CORP.  
 2 LOCTITE GRADE "A" MARK OWNED BY LOCTITE CORP.

Figure 3. Type 98L Relief Valve Assembly Drawing

Key	Description	Part Number	Key	Description	Part Number
15	Adjusting Screw, steel pl 1/4-inch body Standard	1E6399 28992	17	Jam Nut, steel zinc plated 1/4-inch body	1A3522 24122
	1/2-inch body Standard	1D9954 48702		1/2-inch body	1A3537 24122
	For handwheel 3/4 and 1-inch bodies	1J4964 28982		3/4 and 1-inch bodies	1A3192 24122
	Standard	1A3308 28982		1-1/2 and 2-inch bodies Type 98H only	1A3681 24112
	1-1/2 and 2-inch bodies Standard, Type 98H only	1A6801 28992	18	Drive Screw (not shown) Stainless steel (2 req'd)	1A3682 28982
16	Cap Screw, steel pl Type 98L		19*	Diaphragm Gasket, elastomer Use w/302 stainless steel diaphragm Type 98H	
	1/4-inch body (10 req'd)	1A4078 24052		1/4-inch body	1E3931 04022
	1/2-inch body (10 req'd)	1A3816 24052		1/2-inch body	1E3961 04022
	3/4 and 1-inch bodies (12 req'd)	1A3369 24052		3/4 and 1-inch bodies	1E3993 04022
	Type 98H			1-1/2 and 2-inch bodies	1P7879 04022
	1/4-inch body (6 req'd)	1A3917 24052		Type 98L	
	1/2-inch body (8 req'd)	1A3526 24052		1/4-inch body	1E3940 04022
	3/4 and 1-inch bodies (8 req'd)	1A3418 24052		1/2-inch body	1E3970 04022
	1-1/2 and 2-inch bodies (8 req'd)	1K5684 28982		3/4 and 1-inch bodies	1E3904 04022

# BLACKMER PUMP PARTS LIST

MODELS: LGL2E, TLGLD2E, LGL3E, TLGLD3E

(See Instructions 585/E for Operation and Maintenance)

960418

PARTS LIST NO. 585/E1

Section  
Effective  
Replaces

500  
April 1990  
November 1988

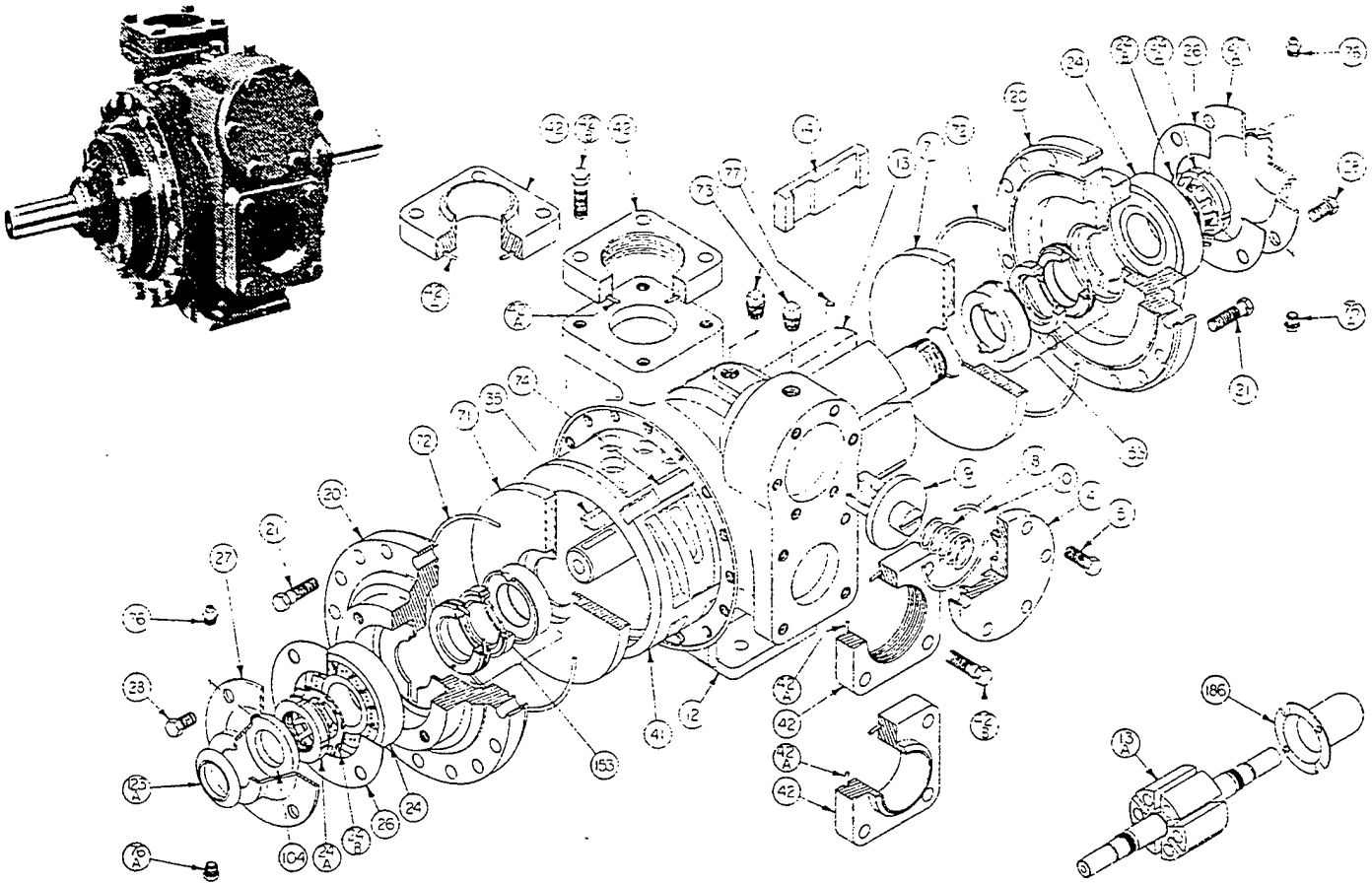

REF. NO.	PART NAME	PARTS PER PUMP	SIZE 2 PART NO.	SIZE 3 PART NO.	REF. NO.	PART NAME	PARTS PER PUMP	SIZE 2 PART NO.	SIZE 3 PART NO.
4	Cover - Relief Valve (R/V)	1	414401	415113	28	Capscrews - Bearing Cover (Size 2)	8	920285	N/A
5	Capscrews - R/V Cover	6	920331	920331		Capscrews - Bearing Cover (Size 3)	12	N/A	920285
8	Spring - R/V	1	*471423	*475135	35	Key - Shaft	1	*909130	*909130
9	Valve - R/V (Std.)	1	*454405	*455129	41	Liner	1	184405	185111
	Valve - R/V (Nickel Plated)		454406	455100	42	Flange - NPT	2	654401	655112
10	O-Ring - R/V Cover	1	*701919	*701925		Flange - Weld		654405	655102
12	Casing	1	014405	015127	42A	O-Ring - Flange	2	*702004	*702002
13	Rotor & Shaft Asy. - LGL (Includes Ref. Nos. 24A & 24B)	1	264443	265149	42B	Capscrew - NPT Flange	8	920384	920547
13A	Rotor & Shaft Asy. - TLGLD** (Includes Ref. Nos. 24A & 24B)	1	264445	265148		Capscrew - Weld Flange		920351	920510
14	Vane - Duravane (Std.)	6	*091419	*095131	71	Disc	2	*064412	*065112
	Vane - Laminate		091427	095109	72	O-Ring - Head	2	*702022	*702041
20	Head	2	034416	035128	73	Gage Plug	2	908195	908195
21	Capscrews - Head (Size 2)	32	920351	N/A	74	Key - Liner	1	184407	185191
	Capscrews - Head (Size 3)	40	N/A	920369	76	Grease Fitting	2	317815	317815
24	Ball Bearing	2	*903156	*903166	76A	Grease Relief Fitting	2	701992	701992
24A	Locknut - Bearing	2	903521	903523	77	Push Rod	3	*123905	*125105
24B	Lockwasher - Bearing	2	*903522	*903524	104	Grease Seal	1 (2)	*331918	*331908
26	Gasket - Bearing Cover	2	*383940	*385125	123A	Dirt Shield	1 (2)	*701480	N/A
27	Bearing Cover (Inboard)	1 (2)	041431	041815	186	Shaft Protector (TLGLD Models Only)	1	341601	341801
27A	Bearing Cover (Outboard)	1 (3)	041433	041817		Pump Repair Kit		894420	895127

\* Parts Included in Pump Repair Kits.

\*\*Double-Ended Rotor & Shaft.

The Following applies to pump models TLGLD2E & TLGLD3E: (1) Use One (2) Use Two (3) Use None

MECHANICAL SEAL - STANDARD

REF. NO.	PART NAME	PARTS PER PUMP	SIZE 2 PART NO.	SIZE 3 PART NO.
153	Mechanical Seal Assembly	2	*331652	*335125
153A	Stationary Seat (Steel)	2	331828	335126
153B	Seal Face (Carbon)	2	331609	331867
153C	Jacket Assembly	2	331651	335128
153D	O-Ring - Stationary (Buna-N)	2	711924	702025
153E	O-Ring - Rotating (Buna-N)	2	711918	711912

\* Included in Pump Repair Kit.

MECHANICAL SEAL - OPTIONAL (MAPP GAS)

REF. NO.	PART NAME	PARTS PER PUMP	SIZE 2 PART NO.	SIZE 3 PART NO.
153	Mechanical Seal Assembly	2	331656	335129
153A	Stationary Seat (Steel)	2	331828	335126
153B	Seal Face (Carbon)	2	331609	331867
153C	Jacket Assembly	2	331651	335128
153D	O-Ring - Stationary (Viton)	2	701970	702015
153E	O-Ring - Rotating (Viton)	2	701980	701962

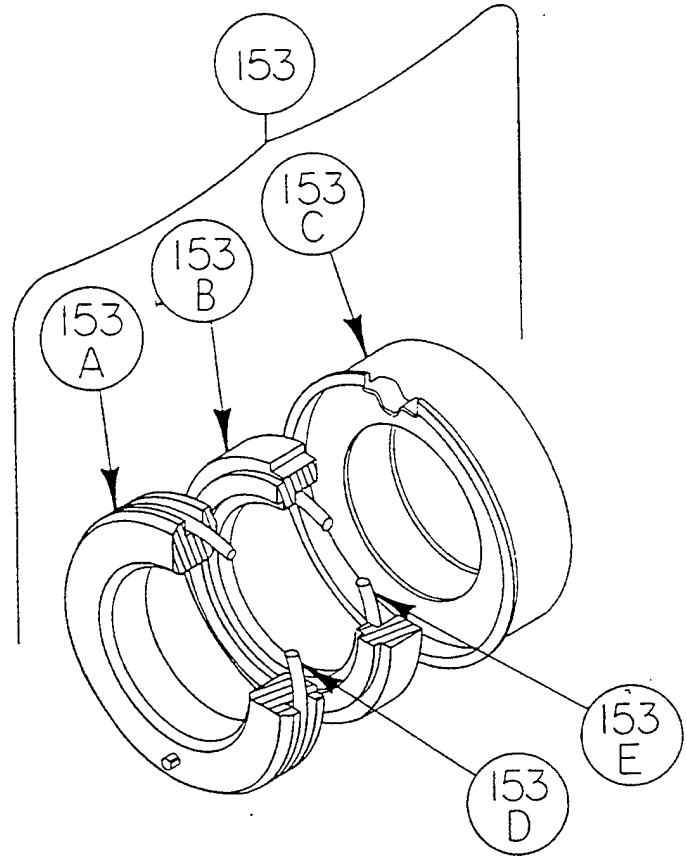

# ***APPENDIX C***

***SPARE PARTS LIST***



Innovative Liquid Vaporizing  
and Gas Mixing Solutions

1140 NW 46 Street  
Seattle, WA 98107 USA  
206-789-5410  
206-789-5414 (Fax)  
www.algas-sdi.com

DATA SHEET  
STABILAIRE LIQUID LPG PUMP

Model: BS1                      Serial Number: 9908459  
Year Built: 1999                Type of Service: LIQUID LPG  
Customer Name: AUTOMATED ENERGY SYSTEMS  
Options:

Job Number: 14679E  
PN: 10864

ELECTRICAL SPECIFICATIONS:

Equipment Drawing: 1104-6001                      Sht 1, Rev. E  
Electrical Drawing: 1101-7002                      Sht 1, Rev. D  
Input Electrical Power: 240 Volts,                      3.6 Amps  
3 Phase,                      3 Wire,                      60 Hz.

SPECIFICATIONS:

Pump Type: Positive Displacement Sliding Vane  
Pump Manufacturer: BLACKMER  
Pump Model Number: LGF1  
Operating Pressure Range: 70-140 PSIG  
Economy Pressure Switch Settings: NA PSIG  
Internal Relief Valve Setting: 105 PSI  
First Stage Differential Relief Valve Settings: NA PSI  
Overload Heaters:                      Yes: X,                      No: \_\_\_\_\_,                      Size: W40

Wiring: Meets NFPA Pamphlet 70 requirements for Class I, Division 1, Group D

PART NUMBER	DESCRIPTION	DRAWINGS	REV
10864	STABILAIRES BS 1 1-HP 70-140PSI 240V/3PH/60HZ	1104-6001	E
		1104-2001	C
		1101-7002	D

RECOMMENDED SPARE PARTS	SDI P/N	PARENT P/N DESCRIPTION	SDI P/N	QTY INSTALLED
-	-----	STR MAN SZ0/3P 380 TO 575V-5HP, 230V-3HP 30147		1.0000
-	-----	GAU 0-300 PSI BKMT LIQ DUAL SCALE 431-03 30639		2.0000
-	-----	STRAINER 600 WOG 1 1/4" #581 WYE 468-120 30657		1.0000
-	-----	VALVE BKCHK 3/4" SFTST 400 WOG 485-0715 30675		2.0000
-	-----	VALVE HYDRO RLF 1/4" 400PSI	30791	1.0000
-	-----	PUMP ONLY LGF1	33352	1.0000
RPR KIT LGF1 PUMP	40432			
-	-----	MTR EXP 1HP 230V/460V 3PH 1800 RPM 56C F 35947		1.0000
-	-----	VALVE BALL 3/4" BRASS,485-0711	35019	1.0000
-	-----	VALVE ABS RLF 1/2" 70-140PSI COMP DIA,25 35574		1.0000

**APPENDIX D**  
**MATERIAL SAFETY DATA SHEET**  
**FOR PROPANE**

OHS19690

-----  
SECTION 1 CHEMICAL PRODUCT AND COMPANY IDENTIFICATION  
-----

MDL INFORMATION SYSTEMS, INC.  
1281 Murfreesboro Road, Suite 300  
Nashville, TN 37217-2423  
1-615-366-2000

EMERGENCY TELEPHONE NUMBER:  
1-800-424-9300 (NORTH AMERICA)  
1-703-527-3887 (INTERNATIONAL)

SUBSTANCE: PROPANE

## TRADE NAMES/SYNONYMS:

N-PROPANE; DIMETHYLMETHANE; PROPYL HYDRIDE; R-290; PROPYLHYDRIDE; LIQUEFIED  
PETROLEUM GAS; LPG; STCC 4905781; UN 1978; C3H8; OHS19690; RTECS TX2275000

CHEMICAL FAMILY: hydrocarbons, aliphatic

CREATION DATE: Apr 26 1985  
REVISION DATE: Sep 10 1998

-----  
SECTION 2 COMPOSITION, INFORMATION ON INGREDIENTS  
-----

COMPONENT: PROPANE  
CAS NUMBER: 74-98-6  
EC NUMBER (EINECS): 200-827-9  
EC INDEX NUMBER: 601-003-00-5  
PERCENTAGE: 100

-----  
SECTION 3 HAZARDS IDENTIFICATION  
-----

NFPA RATINGS (SCALE 0-4): HEALTH=1 FIRE=4 REACTIVITY=0

## EC CLASSIFICATION (ASSIGNED):

F+ Extremely Flammable

R 12

EC Classification may be inconsistent with independently-researched data.

## EMERGENCY OVERVIEW:

COLOR: colorless  
PHYSICAL FORM: gas  
ODOR: distinct odor

MAJOR HEALTH HAZARDS: central nervous system depression, difficulty breathing  
PHYSICAL HAZARDS: Flammable gas. May cause flash fire. Flash back hazard.  
Electrostatic charges may be generated by flow, agitation, etc.

POTENTIAL HEALTH EFFECTS:

INHALATION:

SHORT TERM EXPOSURE: nausea, vomiting, headache, symptoms of drunkenness, disorientation, convulsions, coma

LONG TERM EXPOSURE: same as effects reported in short term exposure

SKIN CONTACT:

SHORT TERM EXPOSURE: no information on significant adverse effects

LONG TERM EXPOSURE: no information on significant adverse effects

EYE CONTACT:

SHORT TERM EXPOSURE: no information on significant adverse effects

LONG TERM EXPOSURE: no information is available

INGESTION:

SHORT TERM EXPOSURE: ingestion of a gas is unlikely

LONG TERM EXPOSURE: ingestion of a gas is unlikely

CARCINOGEN STATUS:

OSHA: N

NTP: N

IARC: N

---

SECTION 4 FIRST AID MEASURES

---

INHALATION: When safe to enter area, remove from exposure. Use a bag valve mask or similar device to perform artificial respiration (rescue breathing) if needed. Keep warm and at rest. Get medical attention immediately.

SKIN CONTACT: Wash if needed. If frostbite, freezing, or cryogenic burns occur, warm affected area in warm water. If this is not available, gently wrap affected parts in blankets. Allow circulation to return naturally. Get medical attention immediately.

EYE CONTACT: It is unlikely that emergency treatment will be required. Wash with large amounts of water or normal saline until no evidence of chemical remains (at least 15-20 minutes). Get medical attention immediately.

INGESTION: It is unlikely that emergency treatment will be required. Get medical attention, if needed.

NOTE TO PHYSICIAN: For inhalation, consider oxygen.

---

SECTION 5 FIRE FIGHTING MEASURES

---

FIRE AND EXPLOSION HAZARDS: Severe fire hazard. Severe explosion hazard. Vapor/air mixtures are explosive. The vapor is heavier than air. Vapors or gases may ignite at distant ignition sources and flash back. Electrostatic discharges may be generated by flow or agitation resulting in ignition or explosion.

EXTINGUISHING MEDIA: carbon dioxide, regular dry chemical

Large fires: Flood with fine water spray.

FIRE FIGHTING: Move container from fire area if it can be done without risk. Cool containers with water spray until well after the fire is out. Stay away from the ends of tanks. For fires in cargo or storage area: Cool containers with water from unmanned hose holder or monitor nozzles until well after fire is out. If this is impossible then take the following precautions: Keep unnecessary people away, isolate hazard area and deny entry. Let the fire burn. Withdraw immediately in case of rising sound from venting safety device or any discoloration of tanks due to fire. For tank, rail car or tank truck: Stop leak if possible without personal risk. Let burn unless leak can be stopped immediately. For smaller tanks or cylinders, extinguish and isolate from other flammables. Evacuation radius: 800 meters (1/2 mile). Stop flow of gas.

FLASH POINT: -157 F (-105 C)  
LOWER FLAMMABLE LIMIT: 2.1%  
UPPER FLAMMABLE LIMIT: 9.5%  
AUTOIGNITION: 842 F (450 C)

---

#### SECTION 6 ACCIDENTAL RELEASE MEASURES

---

##### OCCUPATIONAL RELEASE:

Avoid heat, flames, sparks and other sources of ignition. Do not touch spilled material. Stop leak if possible without personal risk. Reduce vapors with water spray. Keep unnecessary people away, isolate hazard area and deny entry. Remove sources of ignition. Ventilate closed spaces before entering.

---

#### SECTION 7 HANDLING AND STORAGE

---

Store and handle in accordance with all current regulations and standards. Subject to storage regulations: U.S. OSHA 29 CFR 1910.110. Grounding and bonding required. Keep separated from incompatible substances.

---

#### SECTION 8 EXPOSURE CONTROLS, PERSONAL PROTECTION

---

## EXPOSURE LIMITS:

## PROPANE:

1000 ppm (1800 mg/m3) OSHA TWA  
2500 ppm ACGIH TWA  
1000 ppm (1800 mg/m3) NIOSH recommended TWA  
1800 mg/m3 (1000 ml/m3) DFG MAK 4 times/shift

MEASUREMENT METHOD: Combustible gas meter; NIOSH II(2) # S87

## LIQUIFIED PETROLEUM GAS (LPG):

1000 ppm (1800 mg/m3) OSHA TWA  
1000 ppm (1800 mg/m3) ACGIH TWA  
1000 ppm (1800 mg/m3) NIOSH recommended TWA  
1000 ppm (1750 mg/m3) UK OES TWA  
1250 ppm (2180 mg/m3) UK OES STEL

MEASUREMENT METHOD: Combustible gas meter; NIOSH II(2) # S93

VENTILATION: Ventilation equipment should be explosion-resistant if explosive concentrations of material are present. Ensure compliance with applicable exposure limits.

EYE PROTECTION: Wear splash resistant safety goggles with a faceshield. Provide an emergency eye wash fountain and quick drench shower in the immediate work area.

CLOTHING: For the gas: Protective clothing is not required. For the liquid: Wear appropriate protective, cold insulating clothing.

GLOVES: Wear insulated gloves.

RESPIRATOR: The following respirators and maximum use concentrations are drawn from NIOSH and/or OSHA.

2100 ppm

Any supplied-air respirator.

Any self-contained breathing apparatus with a full facepiece.

Escape -

Any appropriate escape-type, self-contained breathing apparatus.

For Unknown Concentrations or Immediately Dangerous to Life or Health -

Any supplied-air respirator with full facepiece and operated in a pressure-demand or other positive-pressure mode in combination with a separate escape supply.

Any self-contained breathing apparatus with a full facepiece.

---

SECTION 9      PHYSICAL AND CHEMICAL PROPERTIES

---

PHYSICAL STATE: gas  
COLOR: colorless  
ODOR: distinct odor  
MOLECULAR WEIGHT: 44.11  
MOLECULAR FORMULA: C-H3-C-H2-C-H3  
BOILING POINT: -44 F (-42 C)  
FREEZING POINT: -310 F (-190 C)  
VAPOR PRESSURE: 6536 mmHg @ 20 C  
VAPOR DENSITY (air=1): 1.55  
SPECIFIC GRAVITY (water=1): 0.5853 @ -45 C  
WATER SOLUBILITY: very slightly soluble  
PH: Not applicable  
VOLATILITY: 100%  
ODOR THRESHOLD: 5000-20000 ppm  
EVAPORATION RATE: Not applicable  
COEFFICIENT OF WATER/OIL DISTRIBUTION: Not applicable  
SOLVENT SOLUBILITY:  
Soluble: absolute alcohol, ether, chloroform, benzene, turpentine

---

SECTION 10 STABILITY AND REACTIVITY

---

REACTIVITY: Stable at normal temperatures and pressure.

CONDITIONS TO AVOID: Avoid heat, flames, sparks and other sources of ignition.  
Minimize contact with material. Containers may rupture or explode if exposed to heat.

INCOMPATIBILITIES: oxidizing materials, combustible materials

PROPANE:

BARIUM PEROXIDE: Violent exothermic reaction.  
CHLORINE DIOXIDE: Spontaneous explosion.  
PLASTICS, RUBBER, COATINGS: Attacked by liquid propane.  
OXIDIZERS (STRONG): Fire and explosion hazard.

HAZARDOUS DECOMPOSITION:

Thermal decomposition products: oxides of carbon

POLYMERIZATION: Will not polymerize.

---

SECTION 11 TOXICOLOGICAL INFORMATION

---

PROPANE:

TARGET ORGANS: central nervous system  
ADDITIONAL DATA: Stimulants such as epinephrine may induce ventricular

fibrillation.

#### HEALTH EFFECTS:

##### INHALATION:

###### ACUTE EXPOSURE:

PROPANE: Brief exposure to 10,000 ppm caused no symptoms in human subjects; 100,000 ppm produced slight dizziness in a few minutes but was not noticeably irritating to the nose or respiratory tract. High levels may produce disorientation, excitation, excessive salivation, headache and vomiting. In primates, 100,000 ppm produced some myocardial effects and at 200,000 ppm aggravation of these parameters and respiratory depression. Concentrations of 100,000 ppm in mice and 150,000 ppm in dogs appear to produce no arrhythmia but weak cardiac sensitization. Simple asphyxiants at concentrations of 33% may cause rapid respiration, dyspnea and reduced mental alertness and muscle coordination. Concentrations of 75% may produce nausea, vomiting, prostration, unconsciousness, convulsions, deep coma and death.

###### CHRONIC EXPOSURE:

PROPANE: Repeated contact may result in symptoms as described in acute exposure.

##### SKIN CONTACT:

###### ACUTE EXPOSURE:

PROPANE: No adverse effects have been reported from the gas. Due to rapid evaporation, the liquid may cause frostbite with redness, tingling and pain or numbness. In more severe cases, the skin may become hard and white and develop blisters.

###### CHRONIC EXPOSURE:

PROPANE: No adverse effects reported.

##### EYE CONTACT:

###### ACUTE EXPOSURE:

PROPANE: Vapor concentrations of 100,000 ppm were not noticeably irritating to the eyes. Due to rapid evaporation, the liquid may cause frostbite with redness, pain and blurred vision.

###### CHRONIC EXPOSURE:

PROPANE: No data available.

##### INGESTION:

###### ACUTE EXPOSURE:

PROPANE: Ingestion of a gas is unlikely. If the liquid is swallowed, frostbite damage of the lips, mouth and mucous membranes may occur.

###### CHRONIC EXPOSURE:

PROPANE: No data available.

-----  
SECTION 12 ECOLOGICAL INFORMATION  
-----

Not available

-----  
SECTION 13 DISPOSAL CONSIDERATIONS  
-----

Subject to disposal regulations: U.S. EPA 40 CFR 262. Hazardous Waste  
Number(s): D001. Dispose in accordance with all applicable regulations.

-----  
SECTION 14 TRANSPORT INFORMATION  
-----

U.S. DOT 49 CFR 172.101 SHIPPING NAME-UN NUMBER:  
Propane-UN1978

U.S. DOT 49 CFR 172.101 HAZARD CLASS OR DIVISION:  
2.1

U.S. DOT 49 CFR 172.101 AND SUBPART E LABELING REQUIREMENTS:  
Flammable gas

U.S. DOT 49 CFR 172.101 PACKAGING AUTHORIZATIONS:  
EXCEPTIONS: 49 CFR 173.306  
NON-BULK PACKAGING: 49 CFR 173.304  
BULK PACKAGING: 49 CFR 173.314, 315

U.S. DOT 49 CFR 172.101 QUANTITY LIMITATIONS:  
PASSENGER AIRCRAFT OR RAILCAR: Forbidden  
CARGO AIRCRAFT ONLY: 150 kg

LAND TRANSPORT ADR/RID:  
SUBSTANCE NAME: Propane, technically-pure/Propane, technically pure  
UN NUMBER: UN1978  
ADR/RID CLASS: 2  
ITEM NUMBER: 3(b)/2F  
WARNING SIGN/LABEL: 3/3; 13  
HAZARD ID NUMBER: 23

AIR TRANSPORT IATA/ICAO: No classification assigned.

MARITIME TRANSPORT IMDG:  
CORRECT TECHNICAL NAME: Propane  
UN/ID NUMBER: UN1978  
IMDG CLASS: 2(2.1)

EmS No.: 2-07  
MFAG Table No.: 310  
MARINE POLLUTANT: N

---

SECTION 15 REGULATORY INFORMATION

---

U.S. REGULATIONS:

TSCA INVENTORY STATUS: Y

TSCA 12(b) EXPORT NOTIFICATION: Not listed.

CERCLA SECTION 103 (40CFR302.4): N

SARA SECTION 302 (40CFR355.30): N

SARA SECTION 304 (40CFR355.40): N

SARA SECTION 313 (40CFR372.65): N

SARA HAZARD CATEGORIES, SARA SECTIONS 311/312 (40CFR370.21):

ACUTE: Y

CHRONIC: N

FIRE: Y

REACTIVE: N

SUDDEN RELEASE: Y

OSHA PROCESS SAFETY (29CFR1910.119): N

STATE REGULATIONS:

California Proposition 65: N

EUROPEAN REGULATIONS:

EC NUMBER (EINECS): 200-827-9

EC RISK AND SAFETY PHRASES:

R 12 Extremely flammable.

S 2 Keep out of reach of children.

S 9 Keep container in a well-ventilated place.

S 16 Keep away from sources of ignition - No smoking.

GERMAN REGULATIONS:

WATER HAZARD CLASS (WGK): 0 (Official German Classification)

---

SECTION 16 OTHER INFORMATION

---

COPYRIGHT 1984-1999 MDL INFORMATION SYSTEMS, INC. ALL RIGHTS RESERVED.

Licensed to: National Institute of Standards and Technology  
To make unlimited paper copies for internal distribution and use only.

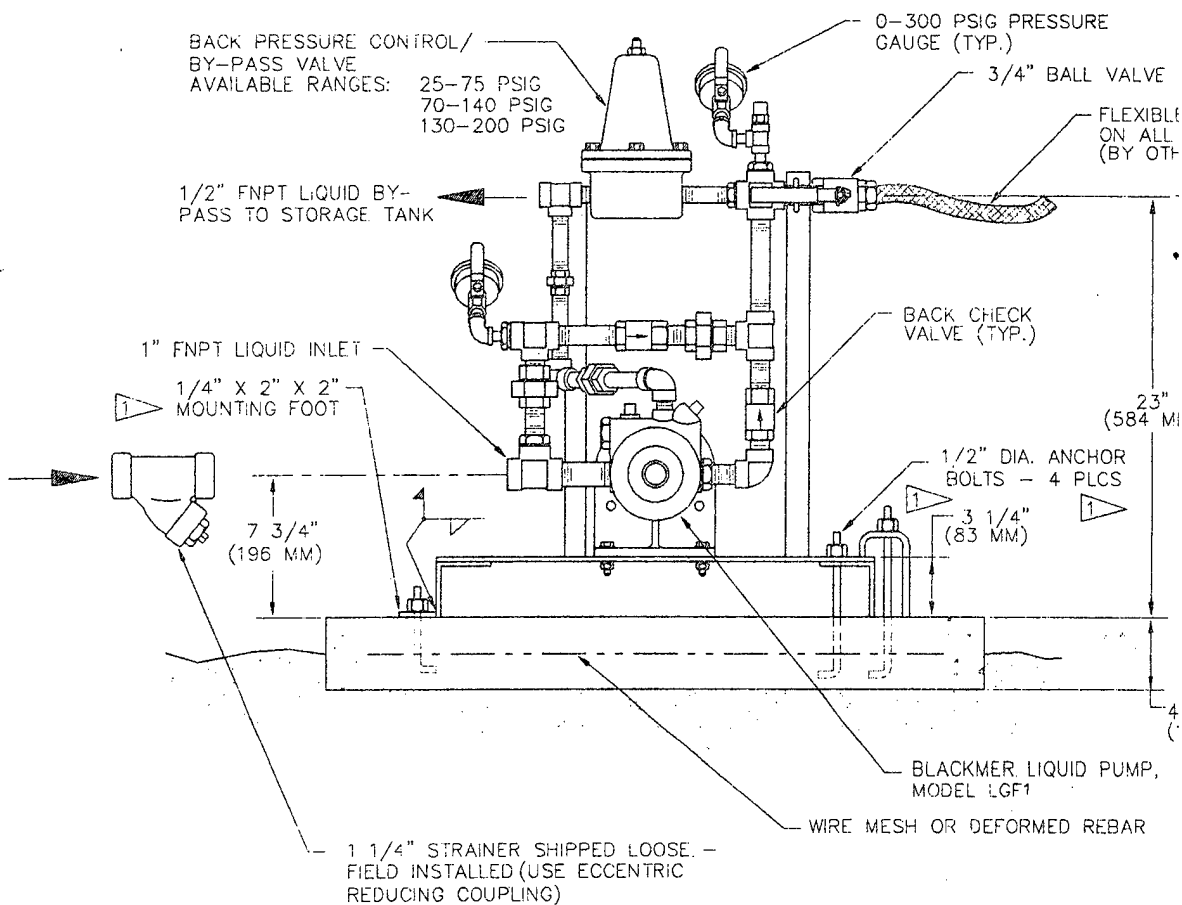
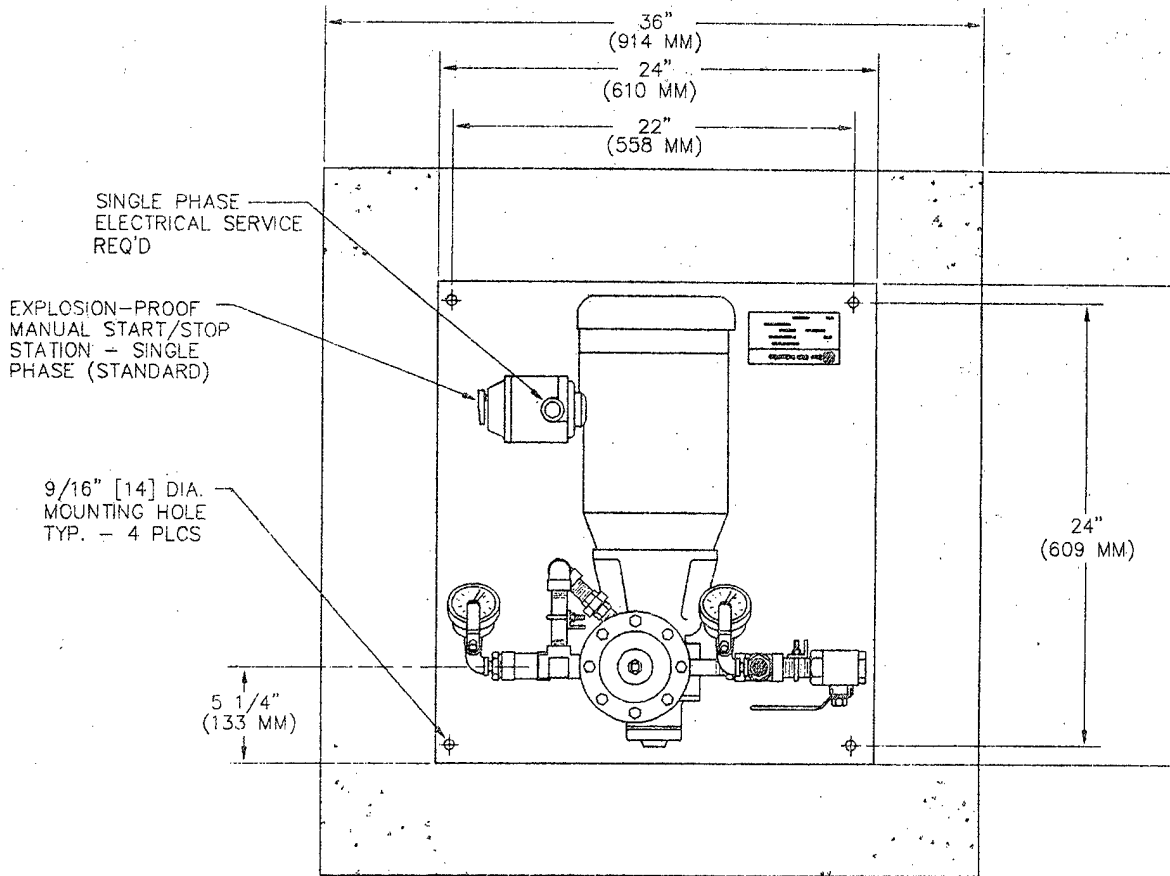

2301

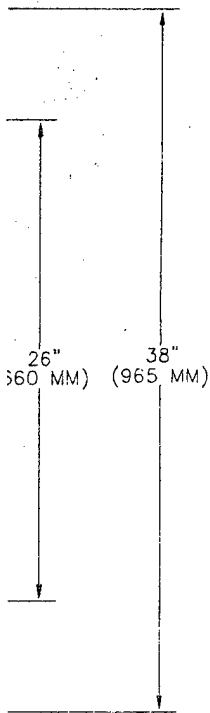

**NOTES**

- 1 RECOMMENDED ANCHORING METHODS
- 2 APPROX. SHIPPING WEIGHT: 200 LBS (91 KG)
- 3 DIMENSIONS SHOWN  $\pm 1/4"$
- 4 MEETS NFPA 70 REQUIREMENTS FOR CLASS I DIV 1 GROUP D
- 5 EXTERIOR: S.D.I. BLUE PER S.D.I. PAINT SPEC. PS-2.

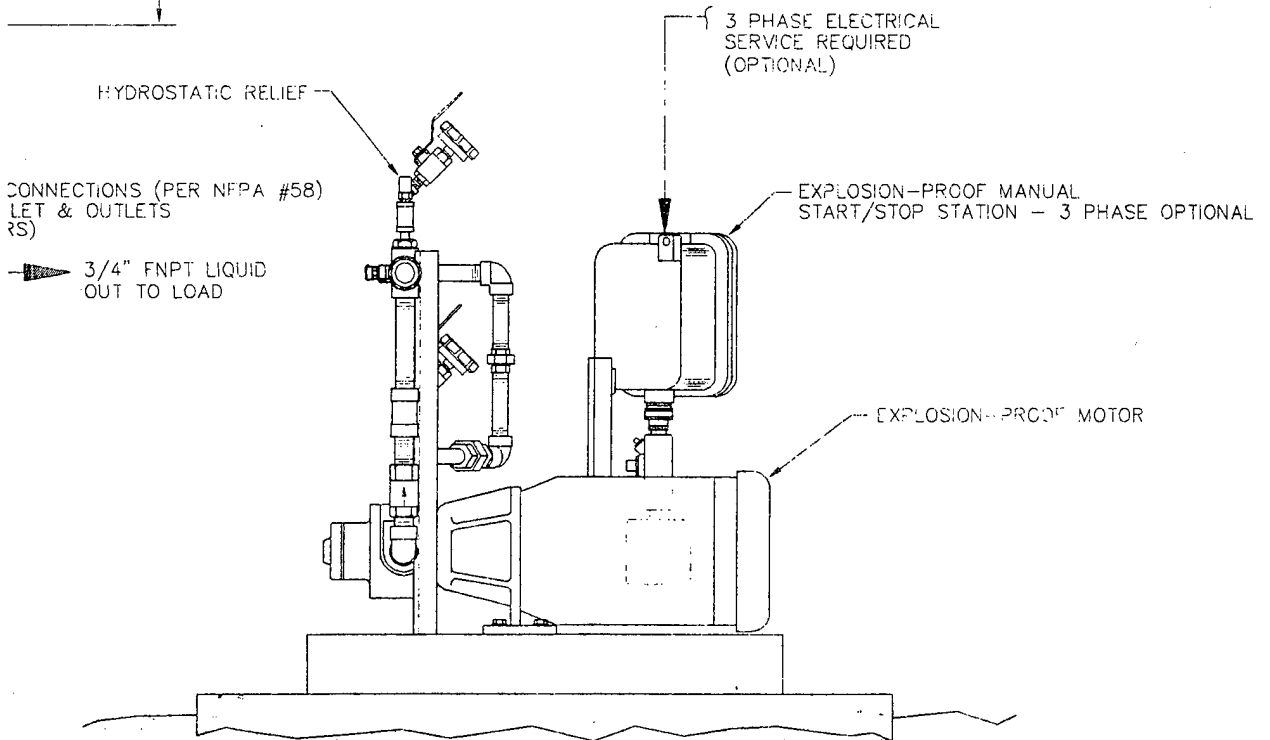

MIN.  
2 MM)

 <b>Sam Dick Industries</b> 1140 N.W. 46th ST, SEATTLE, WA. 98107 TEL: (206) 789-5410 FAX: (206) 789-5414		TITLE "STABILAIRE" LIQUID PUMP MODEL BS-1 EQUIPMENT DRAWING	
		Dwg. No. <b>1104-6001</b>	
Drawn By G. ROPPE	Date 12-11-92	SIZE C	
Checked By <i>EL 1/1/92</i>	Scale NONE	SHEETS 1 OF 1	
Approved By <i>[Signature]</i>	Job No. S.D.I. STD.	REV E	
C.A.D. File No.	Sp. Part No.		

*202*

REV	INITIAL REI
A	
B	1) UP-DATE - SEE PRE
C	1) UP-DA 2) ITEM 6 3) QTY ITE QTY ITE

- 1 ALL JOIN FOR USE
- 2 ITEM 37 & CHICO
- 3 VOLTAGE
- 4 LEAK CH WHEN AS
- 5 COMPLETE TAPE AD
- 6 REMOVE
- 7 CLEANER FIRMLY
- 8 AGENT MOUNTING (SEE PLA
- 9 SEE BOA
- 10 IN LENGTH

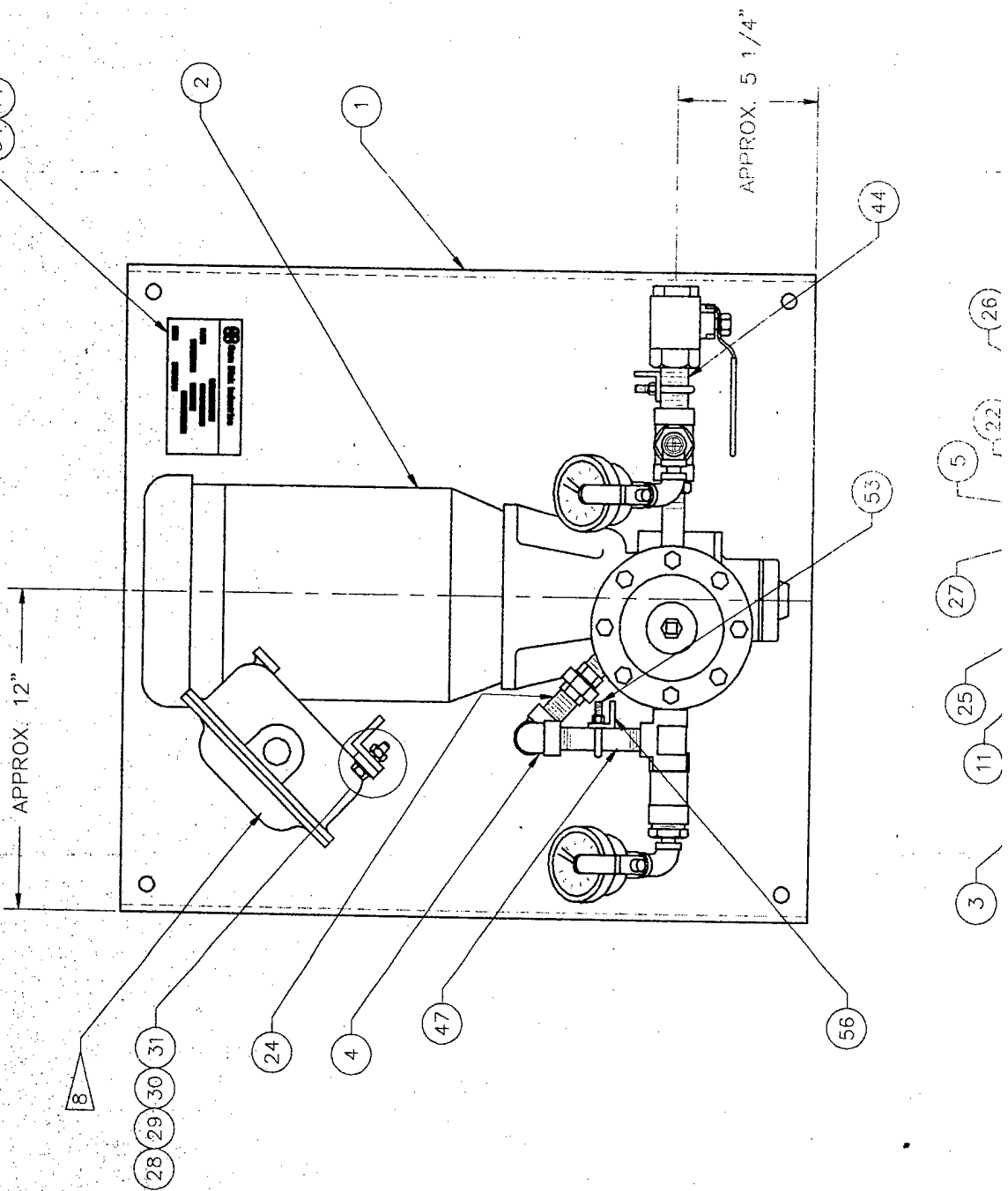

- 3
- 11
- 25
- 27
- 5
- 22
- 26

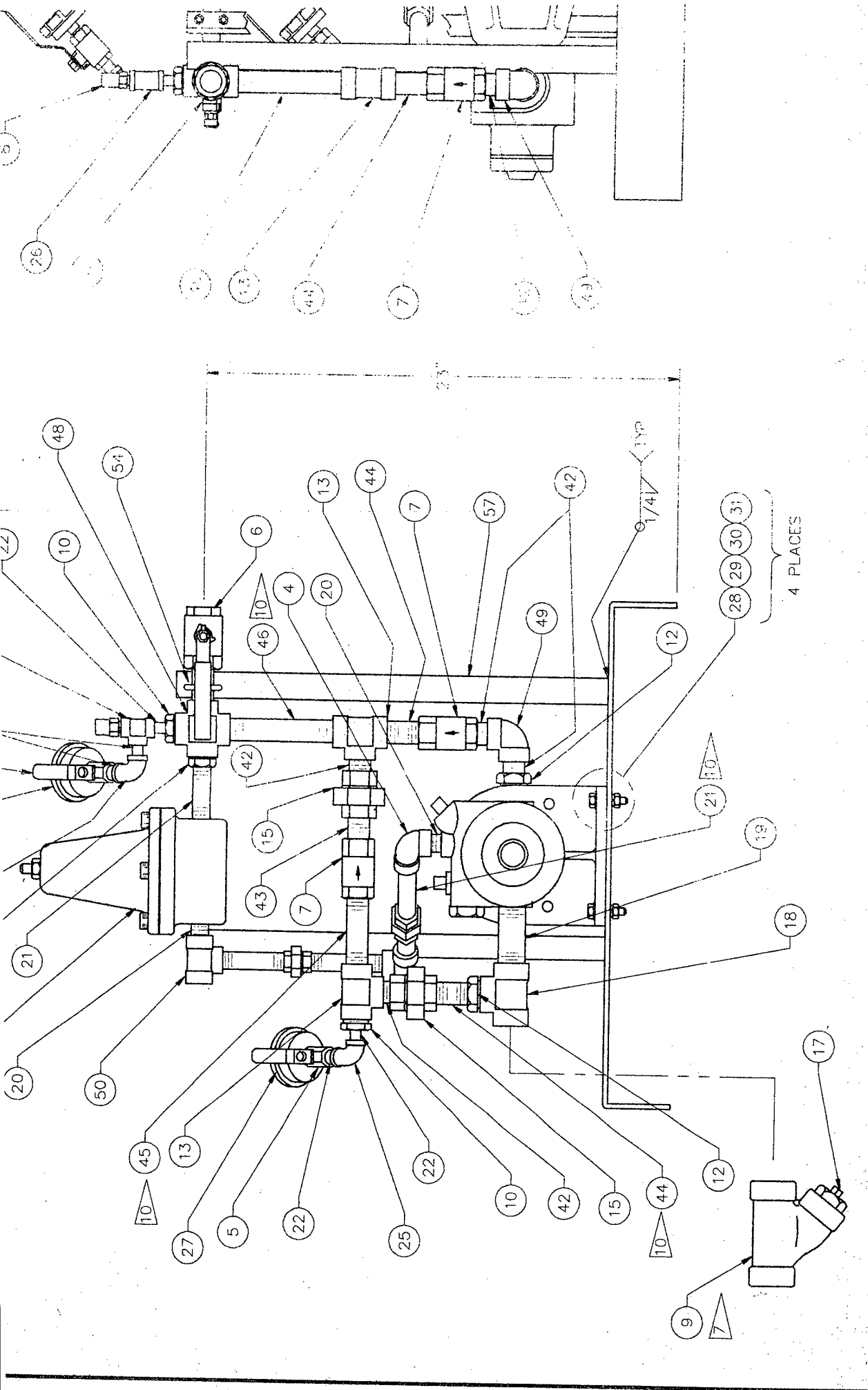

REVISIONS	DESCRIPTION	REV. BY
		G.L.R. 3-1-93
	M. TO AS-BUILT CONFIGURATION REVISION FOR CONFIG. CHANGE	G.L.R. 8-29-94
	PER LATEST CONFIG. UNION BALL VALVE P/N 30705 WAS 2; QTY OF ITEM 21 WAS 3; WAS 1.	G.L.R. 11-1-95

OTES

- BE SEALED WITH PIPE DOPE SUITABLE FOR USE.
- FILL W/CHICO X FIBER MAT'L SEALING COMPOUND (ITEMS 51 & 52).
- BE SPECIFIED BY ENGINEERING.
- W / AIR @ 150 PSIG & SOAP SOLUTION UNTIL IS COMPLETE.
- UNIT IS TO BE PAINTED PER S.D.I./PS-2 SPECIFICATIONS AND ITEMS TO REMAIN UNPAINTED.
- AIR BEFORE SHIPPING.
- TO BE SHIPPED W / UNIT ATTACHED TO INSURE ARRIVAL.
- TO 45° FROM MOTOR TO ALLOW SUPPORT ANGLE (W FOR ORIENTATION)
- FOR SPECIFIC INFORMATION.

REQ'D

(5)

1	60706	ANGLE, 1/4" X 1 1/4" X 1 1/4" X 21" LONG	57
1	30512	ANGLE, 1/4" X 1" X 1" X 21" LONG	56
1	30039	NIPPLE, SCH 80 BLK 1/2" NPT X 4 1/2" LONG	55
1	60050	"U" BOLT W/ NUTS FOR 3/4" PIPE	54
1	60049	"U" BOLT W/ NUTS FOR 1/2" PIPE.	53
A/R	65030	CHICO X SEALING COMPOUND	52
A/R	65031	CHICO X FIBER MAT'L	51
1	30321	TEE, 1/2" FS 2000#	50
1	30383	ELBOW, 3/4" FS 2000#	49
1	30313	CROSS, 3/4" FS 2000#	48
2	30038	NIPPLE, SCH 80 BLK 1/2" NPT X 4" LONG	47
1	30053	NIPPLE, SCH 80 BLK 3/4" NPT X 6" LONG	46
1	30049	NIPPLE, SCH 80 BLK 3/4" NPT X 4" LONG	45
3	30047	NIPPLE, SCH 80 BLK 3/4" NPT X 3" LONG	44
1	30045	NIPPLE, SCH 80 BLK 3/4" NPT X 2' LONG	43
4	30044	NIPPLE SCH 80 BLK 3/4" NPT X 1 1/2" LONG	42
A/R	9	WIRE	41
3, 4, OR 6	65053	WIRE NUT	40
2	30401	NIPPLE SCH 40 GALV 1/2" NPT X 1 1/2"	39
3	9	OVER LOAD HEATERS	38
1	30457	CONDUIT SEAL OFF 1/2" EXF	37
1	30450	CONDUIT BUSHING 1" X 1/2"	36
1	9	MANUAL STARTER, 1HP/3PH	35
1	5251	S.D.I. PUMP NAMEPLATE	34
1	30513	ANGLE, 1/4 X 1 1/2 X 1 1/2 STEEL	33
1	60071	HEX NUT 5/16-18 ZINC PLATED	31
1	60036	LOCK WASHER 5/16" MDM SPLIT ZINC PLATED	30
5	60069	FLAT WASHER 5/16" SAE	29
5	60023	HEX HEAD BOLT 5/16-18 X 1 1/4" LONG	28
2	30639	GAUGE 0-300 PSI BKMT LIQ. DUAL SCALE	27

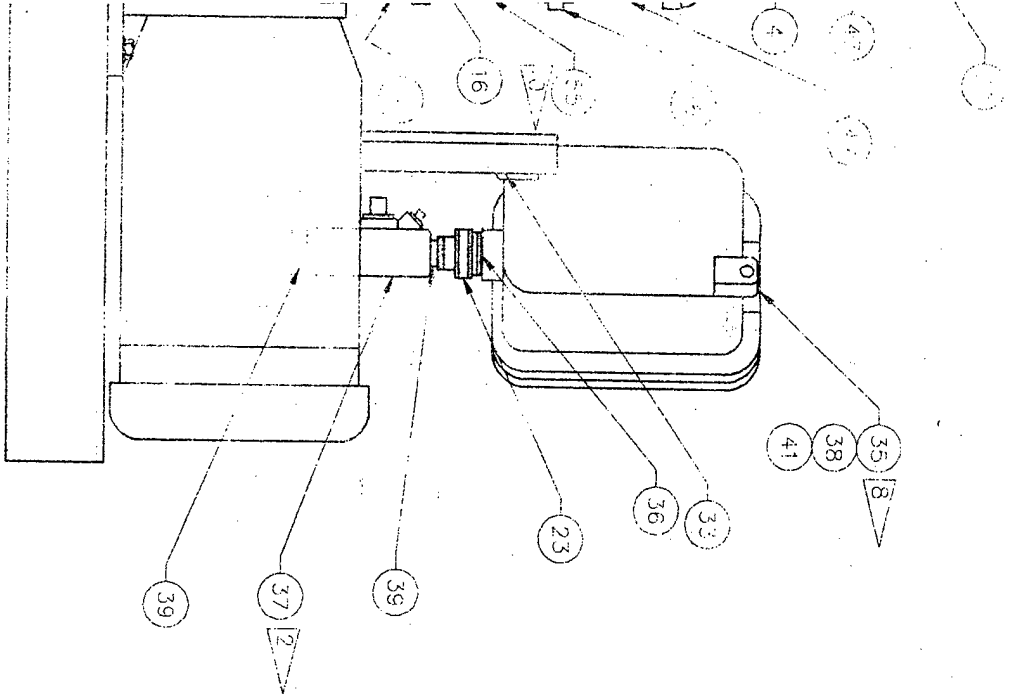

ITEM	DESCRIPTION	PART NO.	QUANTITY	FINISH	TOLERANCES UNLESS OTHERWISE SPECIFIED
25	ELBOW FS 2000# 90° 1/4" NPT FXE	30730	2		
24	NIPPLE, SCH 80 BLK, 1/2" X 2' LONG	30036	1		
23	STR. CONDUIT UNION 1/2" M X F	30473	1		
22	NIPPLE, SCH 80 BLK 1/4" NPT X 1 1/2" LONG	30011	5		
21	NIPPLE, SCH 80 BLK 1/2" X 3 1/2" LONG	30033	2		
20	NIPPLE, SCH 80 BLK 1/2" NPT X 1 1/2" LONG	30033	1		
19	NIPPLE, SCH 80 BLK 1" NPT X 3 1/2" LONG	30722	1		
18	REL. 1" FS 2000#	30722	1		
17	FLUG STEEL 3/4 NPT	30722	1		
16	FLUG FS 2000# STRAIGHT 1/2" NPT FXE	30064	2		
15	FLUG FS 2000# STRAIGHT 3/4" NPT FXE	30285	2		
14	ALUM. ROLL AND MANDREL 1/8" DIA BUTT WELD	80709	1		
13	REL. FS 2000# 3/4" NPT	30324	2		
12	WASHPING, STEEL 1" X 3/4" NPT	30105	2		
11	BUSHING, STEEL 3/4" X 1/2" NPT	30105	1		
10	BUSHING, STEEL 3/4" X 1/2" NPT	30104	2		
9	STRAINER 500 W/O 1 1/4" NPT	30791	1		
8	VALVE HYDRO RELIEF 1/4" 400 PSI	30416	2		
7	VALVE CHECK 3/4" FXE BRONZE SHFT	35019	1		
6	VALVE 3/4" BALL	30792	3		
5	GALL VALVE 1/4" FXE	30792	3		
4	FLUG 1/2" 30° FS 2000#	30792	1		
3	REL. ABSOLUTE RELIEF 1/2"	30792	1		
2	FLUG W/MOTOR, BLACKEN MODEL LG	30792	1		
1	BASE	30792	1		

**Sam Dick Industries**

1140 N.W. 45th St. S.W. Ft. Lauderdale, FL 33309  
 TEL: (305) 751-5100 FAX: (305) 751-5101

Drawn By: G. ROLPE  
 Checked By: [Signature]  
 Date: 11/10/01

Part No. 1104-2001

1 OF 1

FINISH: XX ±  
 XXX ±  
 ANGLE ±

404

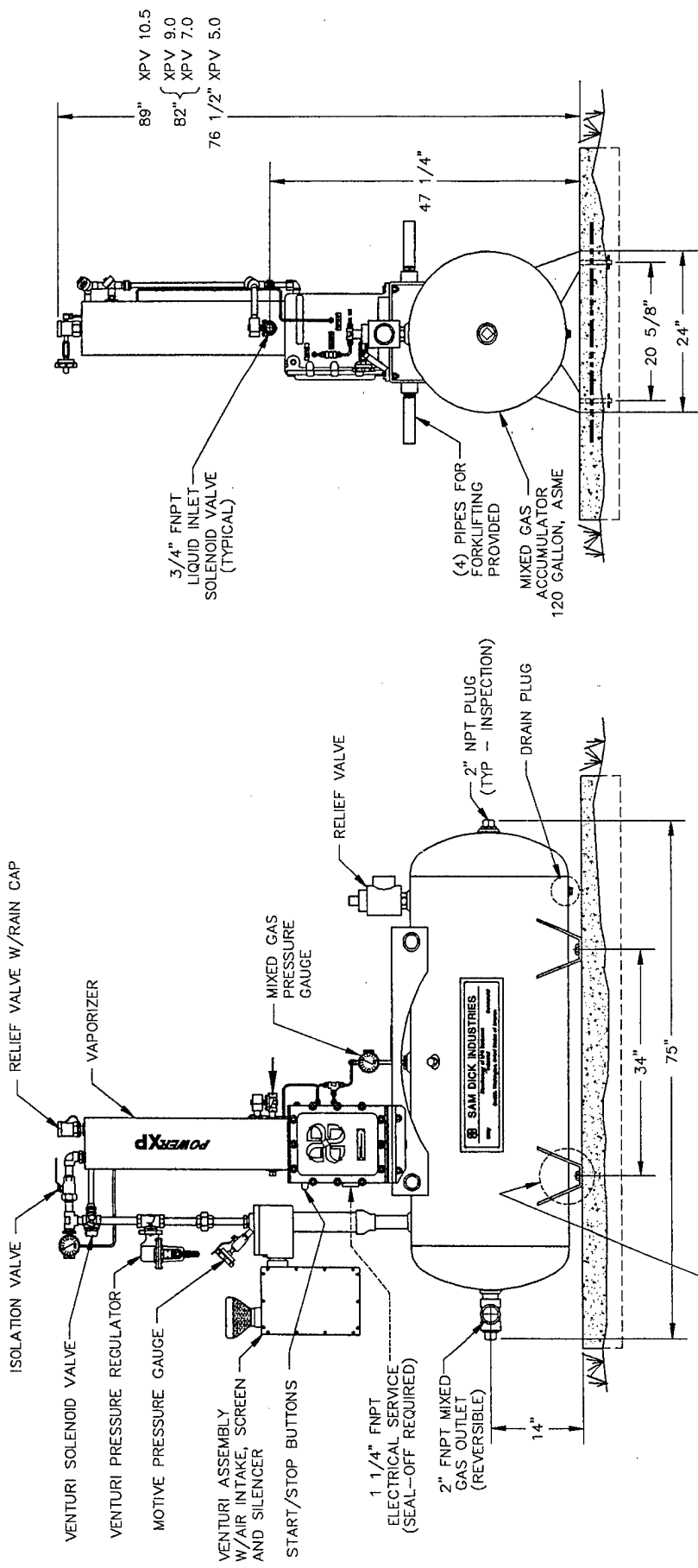

ISOLATION VALVE  
 VENTURI SOLENOID VALVE  
 VENTURI PRESSURE REGULATOR  
 MOTIVE PRESSURE GAUGE  
 VENTURI ASSEMBLY W/AIR INTAKE, SCREEN AND SILENCER  
 START/STOP BUTTONS  
 1 1/4" FNPT ELECTRICAL SERVICE (SEAL-OFF REQUIRED)  
 2" FNPT MIXED GAS OUTLET (REVERSIBLE)  
 14"

RELIEF VALVE W/RAIN CAP  
 VAPORIZER  
 MIXED GAS PRESSURE GAUGE  
 RELIEF VALVE  
 2" NPT PLUG (TYP - INSPECTION)  
 DRAIN PLUG  
 34"  
 75"  
 5/8" DIA. HOLES FOR

89" XPV 10.5  
 82" XPV 9.0  
 76 1/2" XPV 5.0  
 47 1/4"  
 20 5/8"  
 24"  
 3/4" FNPT LIQUID INLET SOLENOID VALVE (TYPICAL)  
 (4) PIPES FOR FORKLIFTING PROVIDED  
 MIXED GAS ACCUMULATOR 120 GALLON, ASME

NOTES

1. FOR USE IN CLASS I DIV. 1 GROUP D LOCATIONS.
2. FOR OUTDOOR INSTALLATION.
3. MAXIMUM WORKING PRESSURE: VAPORIZER(S): 250 PSIG ACCUMULATOR: 50 PSIG MEETS OR EXCEEDS NFPA 58 AND 70 REQUIREMENTS.
4. SHIPPING WEIGHT (APPROX.): MODEL 5.0 = 800 LBS MODEL 7.0 = 850 LBS MODEL 9.0 AND 10.5 = 900 LBS
5. EXTERIOR PAINT "S.D.I. BLUE" PER S.D.I. PAINT SPEC. PS-2

**Sam Dick Industries**

1140 N.W. 46th ST, SEATTLE, WA. 98107  
 TEL: (206) 789-5410 FAX: (206) 789-5414

Drawn By	BRISSON	Date	6-6-94
Checked By	<i>AB/11/98</i>	Scale	NONE
Approved By	<i>[Signature]</i>	Job No.	11/5/88
C.A.D. File No.		SR Part No.	

TITLE

PACKAGED VAPORIZING/  
 MIXING SYSTEM MODELS  
 5.0, 7.0, AND 10.5 - 12 PSIG  
 AND 9.0 - 10 AND 12 PSIG  
 EQUIPMENT DRAWING

DWG. NO.

2001-6002

SIZE

B

SH. NO.

1 OF 1

REV

E

This drawing is the property of SAM DICK INDUSTRIES and is not to be reproduced

REVISIONS		REV. BY	REV. BY
REV	DESCRIPTION	F	J.B.
F	ADDED CONTACTOR DETAIL		10-24-97

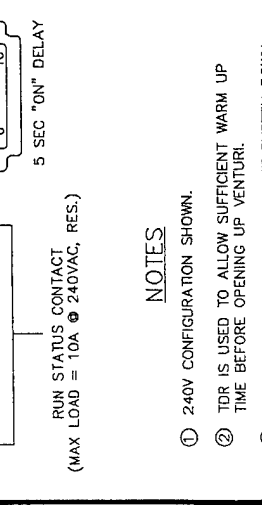
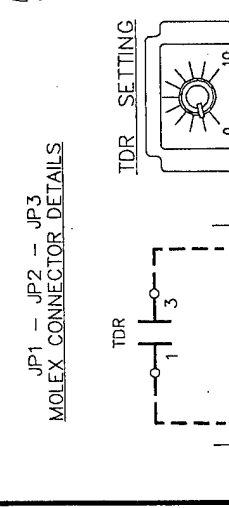
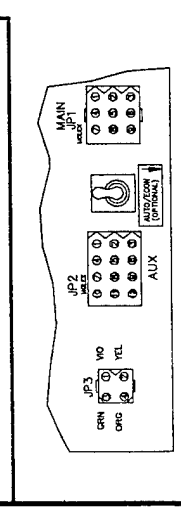
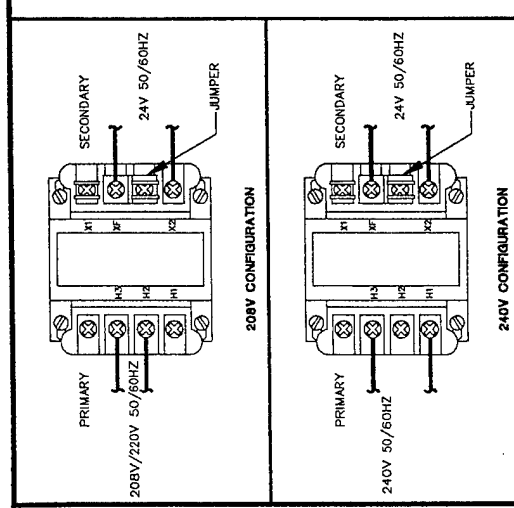
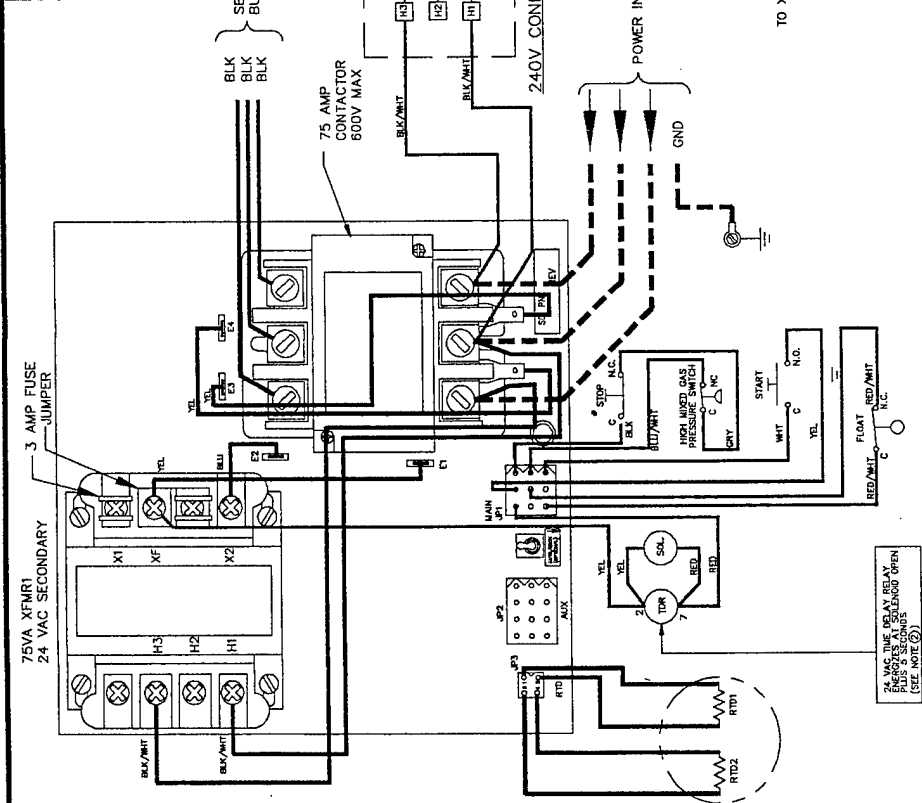

- NOTES**
- ① 240V CONFIGURATION SHOWN.
  - ② TDR IS USED TO ALLOW SUFFICIENT WARM UP TIME BEFORE OPENING UP VENTURI.
  - ③ HIGH TANK PRESSURE WILL SHUT SYSTEM DOWN.

**Sam Dick Industries**  
 1140 N.W. 46th ST, SEATTLE, WA, 98107  
 TEL: (206) 789-5410 FAX: (206) 789-5414

Drawn By: BRISSON  
 Checked By: JB 12-5-97  
 Approved By: ALG 12/5/97

Date: 8-16-93  
 Scale: NONE  
 Job No.: S.D.I. STD.

DATE: 8-16-93  
 SCALE: NONE  
 JOB NO.: S.D.I. STD.

SIZE: B SH NO.: 1 OF 1 REV: F

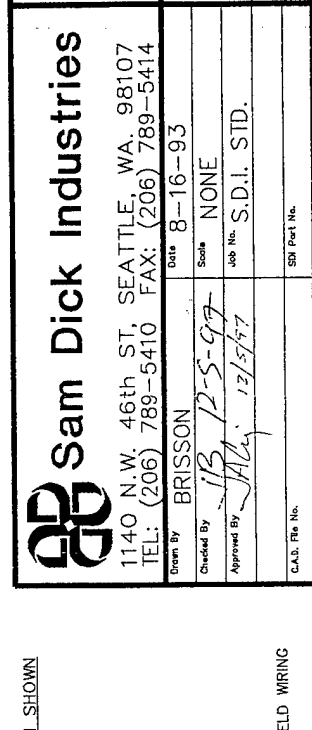

**Sam Dick Industries**  
 1140 N.W. 46th ST, SEATTLE, WA, 98107  
 TEL: (206) 789-5410 FAX: (206) 789-5414

Drawn By: BRISSON  
 Checked By: JB 12-5-97  
 Approved By: ALG 12/5/97

Date: 8-16-93  
 Scale: NONE  
 Job No.: S.D.I. STD.

DATE: 8-16-93  
 SCALE: NONE  
 JOB NO.: S.D.I. STD.

SIZE: B SH NO.: 1 OF 1 REV: F

"XPV" / "XPM" SYSTEM  
 WIRING DIAGRAM 208V THRU 240V  
 3Ø POWER VERTICALS  
 MODELS XP50 THRU XP160  
 W/ 1 GUN VAPORAIRE

2001-7004

THIS DRAWING IS THE PROPERTY OF SAM DICK INDUSTRIES AND IS NOT TO BE REPRODUCED OR USED IN ANY MANNER DETRIMENTAL TO OUR INTERESTS. ALL RIGHTS ARE RESERVED.

**TREE #4**  
**VAPORIZER STARTS AND HEATS UP, BUT VENTURI MIXER DOES NOT OPERATE**

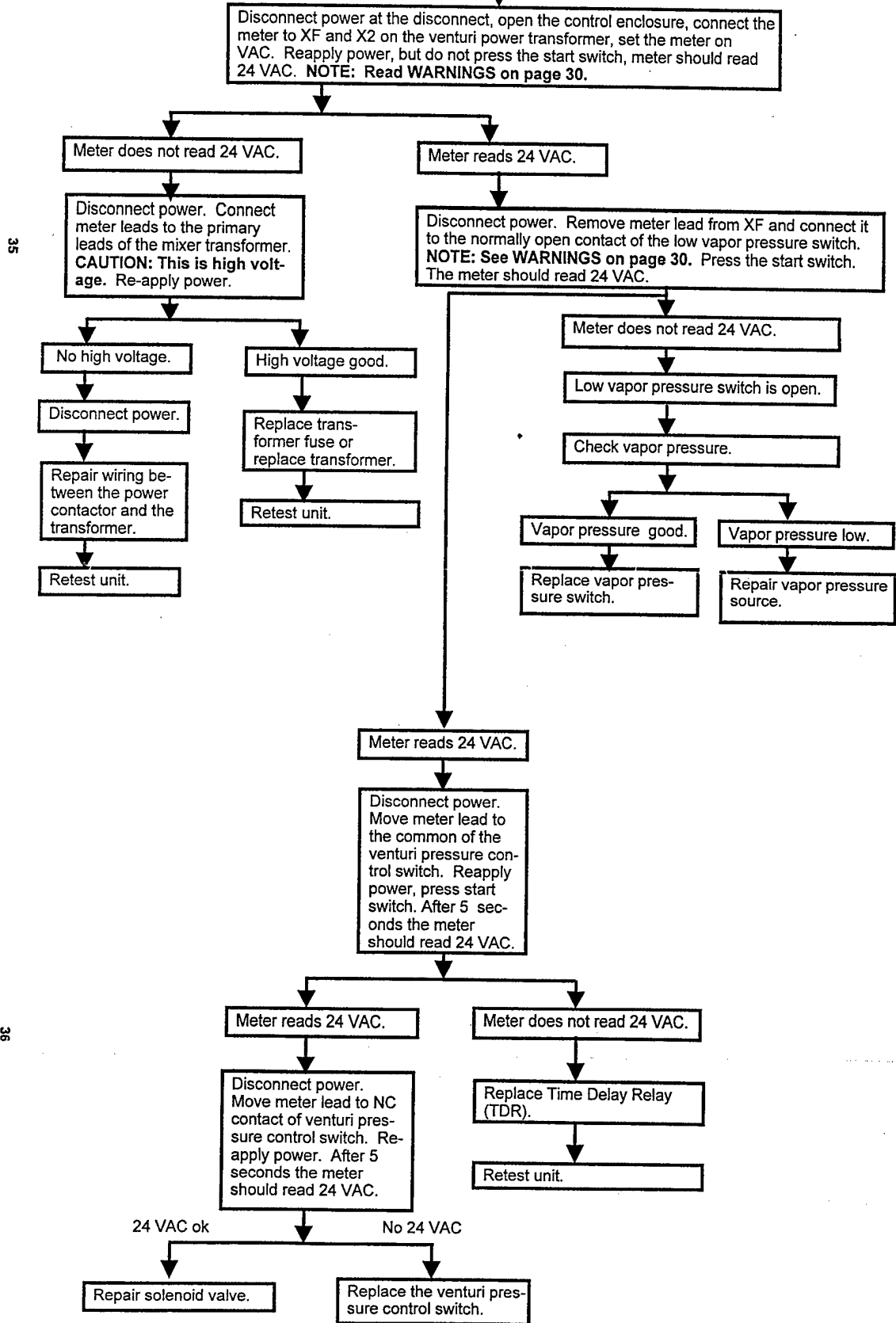

35

36

**TREE #2  
NO REACTION WHEN START SWITCH IS PRESSED**

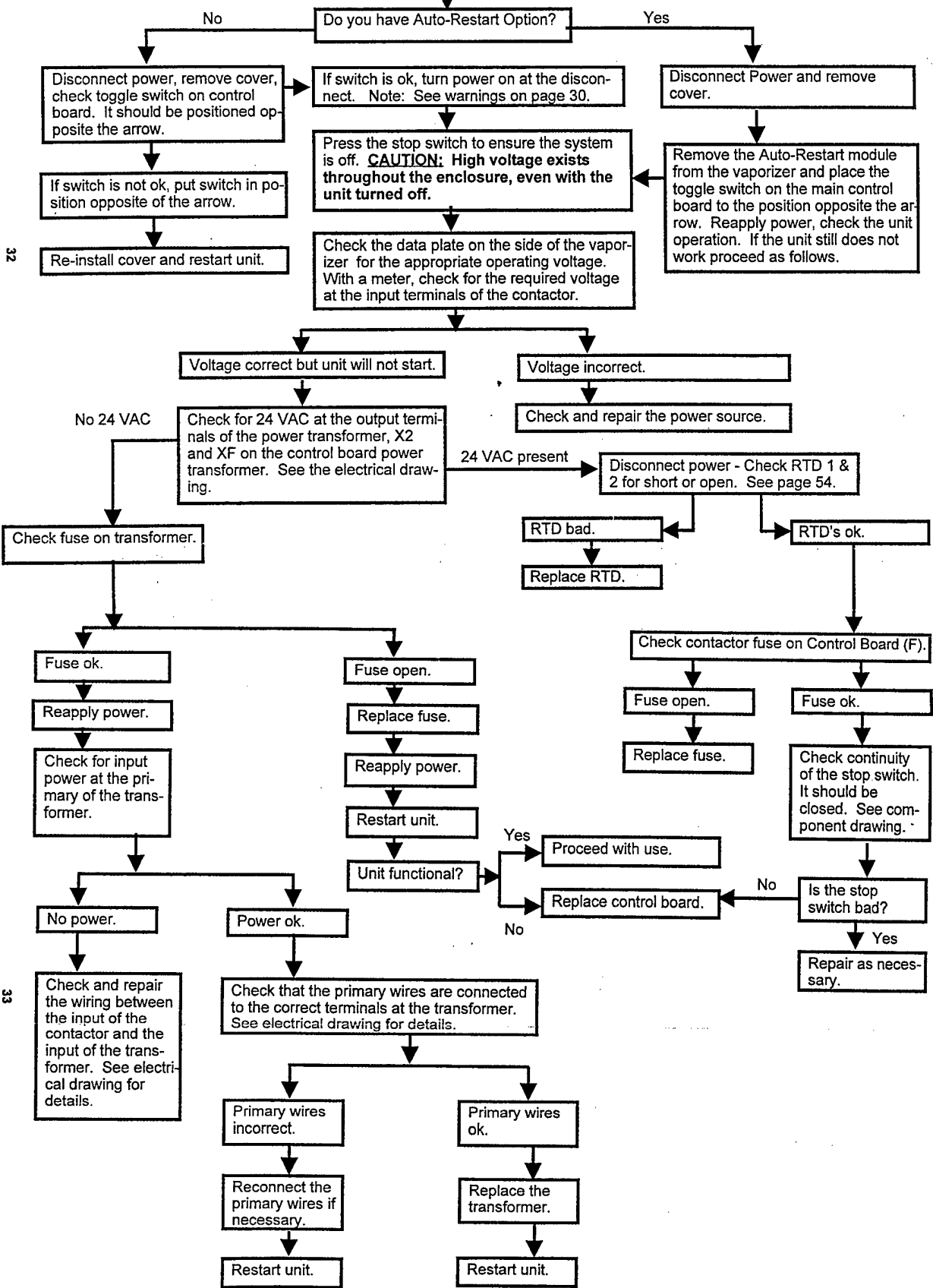

32

33