

UNITED STATES AIR FORCE RESEARCH LABORATORY

HELMET-MOUNTED TRACKER AND DISPLAY (HMT/D) INTERFACES DEVELOPING A "STANDARDIZED" HELMET-VEHICLE INTERFACE (HVI)

Dean F. Kocian

HUMAN EFFECTIVENESS DIRECTORATE
CREW SYSTEM INTERFACE DIVISION
WRIGHT-PATTERSON AFB OH 45433-7022

September 2000

FINAL REPORT FOR THE PERIOD SEPTEMBER 1990 TO SEPTEMBER 2000

Approved for public release; distribution is unlimited

Human Effectiveness Directorate
Crew System Interface Division
2255 H Street
Wright-Patterson AFB OH 45433-7022

NOTICES

When US Government drawings, specifications, or other data are used for any purpose other than a definitely related Government procurement operation, the Government thereby incurs no responsibility nor any obligation whatsoever, and the fact that the Government may have formulated, furnished, or in any way supplied the said drawings, specifications, or other data, is not to be regarded by implication or otherwise, as in any manner licensing the holder or any other person or corporation, or conveying any rights or permission to manufacture, use, or sell any patented invention that may in any way be related thereto.

Please do not request copies of this report from the Air Force Research Laboratory. Additional copies may be purchased from:

National Technical Information Service
5285 Port Royal Road
Springfield, Virginia 22161

Federal Government agencies and their contractors registered with the Defense Technical Information Center should direct requests for copies of this report to:

Defense Technical Information Center
8725 John J. Kingman Road, Suite 0944
Ft. Belvoir, Virginia 22060-6218

TECHNICAL REVIEW AND APPROVAL

AFRL-HE-WP-TR-2002-0105

This report has been reviewed by the Office of Public Affairs (PA) and is releasable to the National Technical Information Service (NTIS). At NTIS, it will be available to the general public.

This technical report has been reviewed and is approved for publication.

FOR THE COMMANDER

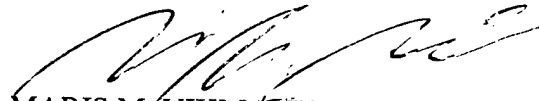

MARIS M. VIKMANIS
Chief, Crew System Interface Division
Air Force Research Laboratory

REPORT DOCUMENTATION PAGE

Form Approved
OMB No. 0704-0188

Public reporting burden for this collection of information is estimated to average 1 hour per response, including the time for reviewing instructions, searching existing data sources, gathering and maintaining the data needed, and completing and reviewing the collection of information. Send comments regarding this burden estimate or any other aspect of this collection of information, including suggestions for reducing this burden, to Washington Headquarters Services, Directorate for Information Operations and Reports, 1215 Jefferson Davis Highway, Suite 1204, Arlington, VA 22202-4302, and to the Office of Management and Budget, Paperwork Reduction Project (0704-0188), Washington, DC 20503.

1. AGENCY USE ONLY (Leave blank)	2. REPORT DATE September 2000	3. REPORT TYPE AND DATES COVERED FINAL September 1990 to September 2000	
4. TITLE AND SUBTITLE Helmet Mounted Tracker and Display (HMT/D) Interfaces, Developing a "Standardized" Helmet-Vehicle Interface (HVI)		5. FUNDING NUMBERS PR: 7184 TA: 11 WU: 46	
6. AUTHOR(S) Dean F. Kocian		8. PERFORMING ORGANIZATION	
7. PERFORMING ORGANIZATION NAME(S) AND ADDRESS(ES)		10. SPONSORING/MONITORING AFRL-HE-WP-TR-2002-0105	
9. SPONSORING/MONITORING AGENCY NAME(S) AND ADDRESS(ES) Air Force Research Laboratory Human Effectiveness Directorate Crew System Interface Division Air Force Materiel Command Wright-Patterson AFB OH 45433-7022		11. SUPPLEMENTARY NOTES	
12a. DISTRIBUTION/AVAILABILITY STATEMENT Approved for public release; distribution is unlimited.		12b. DISTRIBUTION CODE	
13. ABSTRACT (Maximum 200 words) The successful integration of technology and human factors meets its ultimate challenge in the area of military performance. Nowhere are the stakes so high and the competition so rigorous as in the arena of combat. This paper documents the attempt to define, develop, and test a "standardized" interface for helmet-mounted tracker and displays aircraft. The design that has been evolved is based upon active use and refinement in an environment that is as close to combat conditions as resources permit. Many of the design ideas and lessons-learned covered in this paper came either directly or indirectly from pilots and support personnel of the USAF 422 Test and Evaluations Squadron located at Nellis AFB NV.			
14. SUBJECT TERMS ATD, CRT, helmet-mounted display, HMD, helmet-mounted tracker, HMT, HMT/D HVI, OUE, VCATS			15. NUMBER OF PAGES 22
			16. PRICE CODE
17. SECURITY CLASSIFICATION OF REPORT Unclassified	18. SECURITY CLASSIFICATION OF THIS PAGE Unclassified	19. SECURITY CLASSIFICATION OF ABSTRACT Unclassified	20. LIMITATION OF ABSTRACT Unlimited

20020618 155

Helmet Mounted Tracker and Display (HMT/D) Interfaces Developing A "Standardized" Helmet-Vehicle Interface (HVI)

INTRODUCTION

The Visually-Coupled Acquisition and Targeting System (VCATS) achieved first flight on 3 February 1997 in an F-15C aircraft located at Nellis AFB, NV as part of the VCATS Operational Utility Evaluation (OUE) (see Figure 1). It employs an integrated-avionics approach to putting an advanced HMT/D into a fighter aircraft cockpit using the F-15C Improved Head-Up Display (IHUD) electronics built by Boeing. As shown in Figure 1, the VCATS IHUD electronics are designed to drive both a day HMT/D cueing system and a panoramic night vision goggle HUD (PNVG-HUD) cueing and display system. The VCATS OUE also incorporates improved missile assets from Raytheon, modified radar, central computer, and programmable armament control system (PACS) operational flight program (OFF) software, and a low latency HMT/D-missile interface implemented using modified -35 PACS electronics. The VCATS F-15 aircraft include not only the standard test range telemetry data collection system using wing-mounted pods but also special on-board data collection that is self-contained and can supplement test range systems when they are not available. Taken together, the VCATS OUE configuration is robust

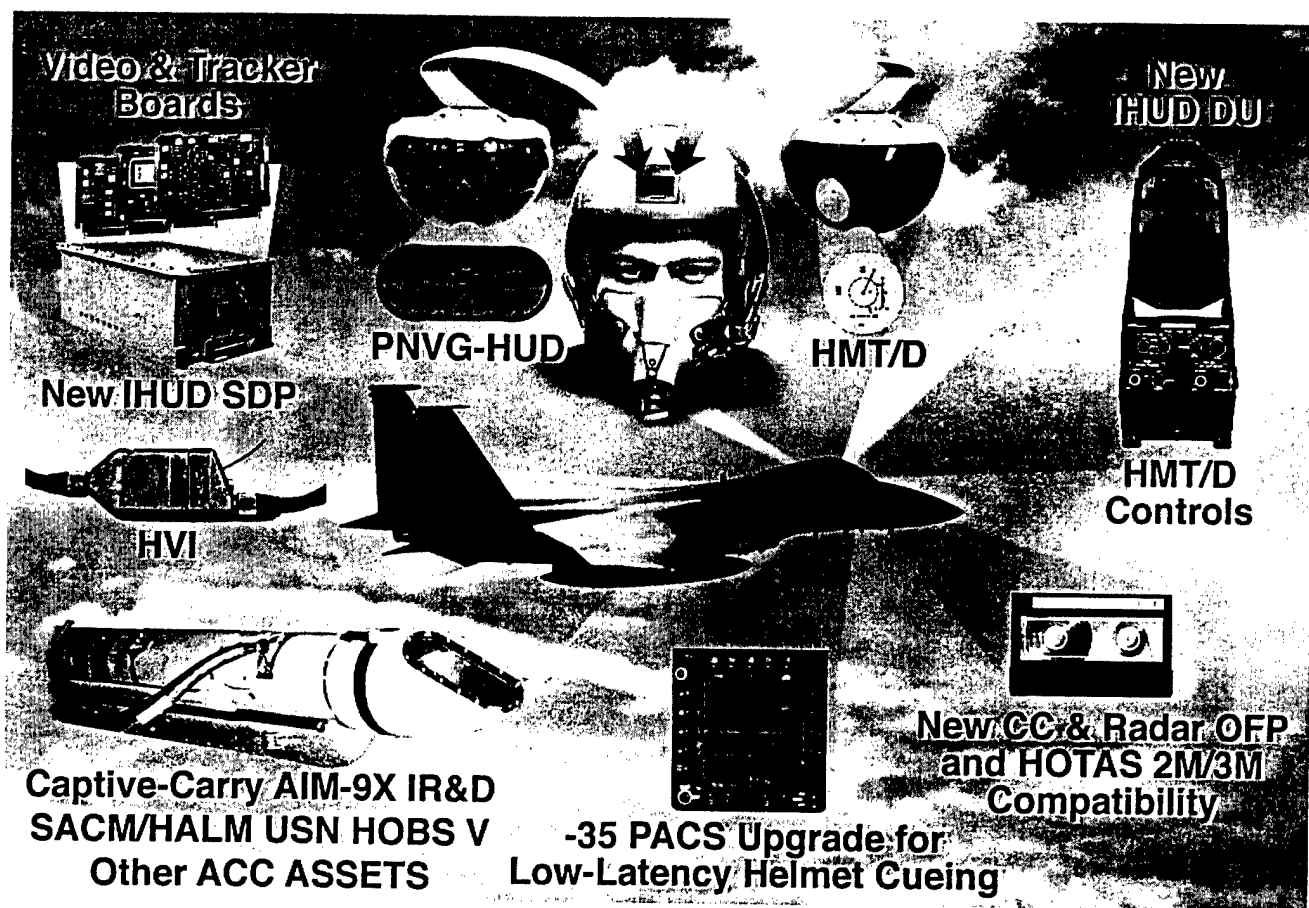

FIGURE 1
Major System Components for VCATS OUE

enough to permit the evaluation of critical human factors engineering criteria, the collection of supporting data, and the evaluation of new technology in a "tactical" air combat environment. The ability to operate in a "tactical" environment as opposed to a simulator or ordinary test aircraft is a key element of the system design and test program. This approach to the electronics integration and test process has and will continue to provide new and unique findings about the design and human use of such systems that can only be ascertained under new combat conditions by combat-qualified pilots. One of the new and advanced elements of the VCATS technology demonstration that is the primary topic of this paper is the development and test of a "standardized" helmet-vehicle interface (HVI) developed with Reynolds Industries, Inc (RII). It significantly improves commonality, safety, reliability, and performance of the HMT/D helmet-to-vehicle interface or HVI.

The HMT/D cable interface between helmet and military vehicle and the interface of electronic devices on either end has been a major weak link for operational military systems. Often, as in the case of the AH-64 Apache Integrated Helmet and Display sighting System (IHADSS), the cable and cathode-ray-tube (CRT) must be discarded regardless of which has failed. This is expensive and prevents good life cycle data from being collected on key components, such as the miniature CRT. The cable interface is often completely hand made, raising costs and is not optimized for technology improvements. Since the interconnect standard is that imposed by the helmet system manufacturer, the substitution of new, different, and improved helmet systems from other vendors is extremely difficult and usually impossible. We can look to other technologies to see how interface standards have improved the performance, cost, and acceptance of new technology. The facsimile system was first demonstrated over telegraph wires in 1847. Succeeding attempts at introducing such a system were hampered until common and accepted interface standards were adopted in the late 1970s and early 1980s./ A similar situation exists for HMT/D systems that limits their potential performance, raises cost, and complicates maintenance in the field or on the bench.

Two versions of the "standardized" HVI have been built. The first, a binocular display version, built to support the Army Light Helicopter Experimental (LHX) virtual panoramic display (VPD) and USN/USAF INSIGHTS HMT/D programs was developed over the 1990-1994 time period. Periodic briefings were given to industry representatives engaged in building military and commercial HMD/Ts in an attempt to develop a common interface standard. The feedback that was received was uneven and broad consensus was not achieved. This is not surprising if one looks at other standardization attempts, such as the High Definition TV standard. The second version was a monocular display designed to operate in ejection seat fighters. The monocular HVI was designed to be used in the VCATS advanced technology demonstration (ATD) program where it had a real chance of long term evaluation in an operational fighter squadron environment and a chance to demonstrate what could be achieved for 6.4 programs like the Joint Helmet Mounted Cueing System (JHMCS) engineering, manufacturing, and development (EM&D) program. The monocular HVI is undergoing further development under the Vista Warrior International Cooperative research and Development (ICR&D) Program to enhance chances for adoption of a joint tri-service and NATO standard. Among the Vista Warrior enhancements being developed are a new, more robust helmet universal connector (US), a new integrated endoliner and energy absorption line that fits in the Gentex lightweight HGU-55/P helmet shell and fully supports the helmet flex cable, a new helmet release connector, and an improved parachute harness interface for the helmet-to-aircraft portion of the HVI cable. This article combines achievements from all three activities to present an up-to-date picture of where development currently stands. The version of the VCATS HVI used to support the VCATS extended-uplook HMT/D and PNVG-HUD will combine the improvements that have accrued from all three development activities.

OVERALL CONCEPT

The development of performance criteria for the "standardized" HVI has been an evolutionary process. It started with an updated known set of limitations developed from experience gained on the LHX, F-16 Night Attack and Mid-Life Update Programs, and F-15 Vista Sabre II program. Briefings explaining program goals were given to industry and military organizations engaged in HMT/D development and operational requirements and feedback was obtained. Critical components of the system were then built and tested in the laboratory and then in field test facilities. This was followed by complete system evaluations performed with personnel familiar with combat operations and production hardware. Finally, a complete HVI system was tested in the larger context of achieving a HMT/D that a pilot could employ in conditions as close to those in combat as resources permit. The generalized, common functionality and performance goals that have evolved to date are:

- 1) A standard mechanical and electrical interface for interconnecting the helmet to the aircraft,
- 2) Non-interference with normal crew station operations and provision for safe, autonomous (unassisted) operation during ejection and ground egress in explosive vapor environments,
- 3) A cable and interconnect system that is light in weight, low profile, durable, and has a cable that is flexible enough to prevent encumbrance of pilot movements,
- 4) Signal bandwidth characteristics and noise immunity for the helmet image source, helmet tracker and camera that covers the full range of military aircraft requirements, including 200 volts per meter electromagnetic interference environments,
- 5) Self-characterization and rapid, simple replacement of helmet-mounted components,
- 6) A system that makes squadron personal equipment (PE) shop support simple and error-free, and
- 7) Support growth options to NVGs, a second display CRT image source or camera, solid state image sources, and cueing/display stabilization processes.

VCATS HVI - GENERAL DESCRIPTION

As shown in Figure 2, the current monocular HVI used in VCATS consists of five modules. Including spares and the high voltage and coaxial leads, these five modules support 62 separate electrical leads (two high voltage, two intermediate voltage, two coax, and 56 low voltage) to the helmet. There is no special logic employed in the module numbering scheme, except to provide an identifiable reference for each component assembly. VCATS has implemented the HMT/D function as an add-on assembly to a modified version of the lightweight Gentex-produced USAF HGU-55/P flight helmet. Module V encompasses the add-on HMT/D module that incorporates the tracker sensor and its associated EEPROM, the display relay optics and visor transparency, the miniature cathode-ray-tube (CRT) and its associated EEPROM, the miniature CCD black and white camera, and the latching side of the helmet universal connector (UC). For the PNVG-HUD function shown in Figure 1, a new add-on module was designed and fabricated. To distinguish this new module from the day HMT/D module, it is designated as Module VI. Module VI also includes the tracker function and the latching side of the helmet UC but no CRT or CCD camera. Modules IV, V and VI utilize to the extent possible lightweight flex-cable assembly interconnects that minimize head-borne cable weight. Module IV incorporates the helmet side of the UC and a special rear-mounted strain relief that helps form a cable service loop for Module III that maximizes left-right and up-down head mobility for the pilot. Module IV also acts as the mounting

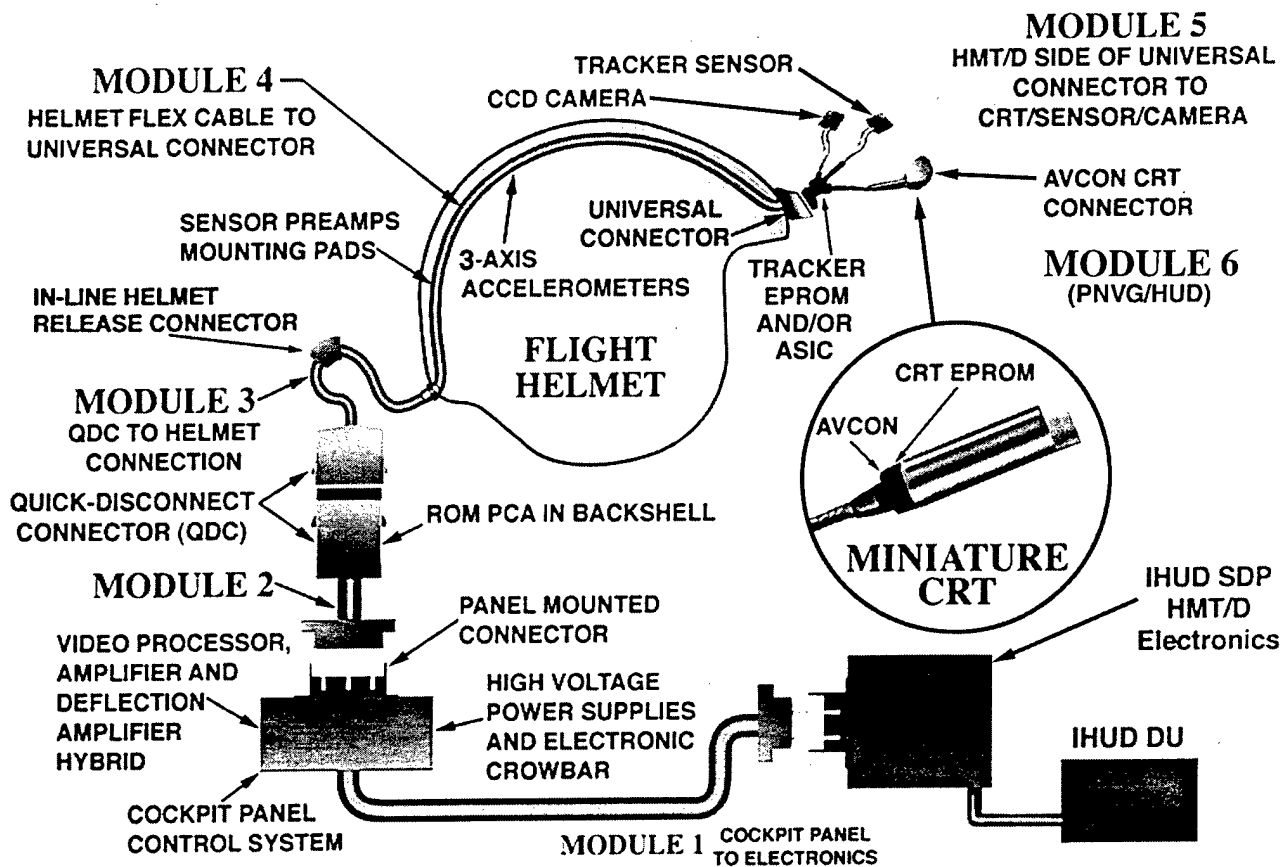

FIGURE 2
Schematic Diagram of HVI Wiring Interconnect

assembly for the VCATS-specific tracker sensor preamplifier and accelerometer electronics. Current technology limits require that the high voltage wires and coaxial wires for the CRT video drive and the CCD camera be run as discrete wires to their respective devices. Module III transitions from a flex-cable signal conduit to a standard wire format. Module III incorporates the helmet release connector to support in-flight ejection accompanied by helmet loss and the top half of the quick-disconnect connector (QDC) used to support safe ejection and rapid ground egress in explosive vapor environments. Module II incorporates the lower half of the QDC that also houses the characterization EEPROM driver electronics and the panel mounted connector. Module I interconnects the system processing electronics located outside the cockpit area with the final signal conditioning electronics located in or near the cockpit. For VCATS, special video hybrids are located in the cockpit panel to maximize signal fidelity while reducing the volume needed for these functions. The VCATS Module I implementation avoids the use of any intervening bulkhead connector feedthroughs to improve signal-to-noise performance between the cockpit and remotely located avionics. Aside from the knowledge the HVI integration design represents, the most important part of the system is its connectors. These require expensive tooling to implement the HVI to the required military standards and extensive testing to verify safety. Within the necessary constraint of maintaining good signal-to-noise performance, the

allocation of signals in the HVI is flexible. Many of the accessory functions shown in Figure 2, such as the accelerometers, sensor preamps, etc., can be made optional. Figure 3 shows the implementation in the F-15C.

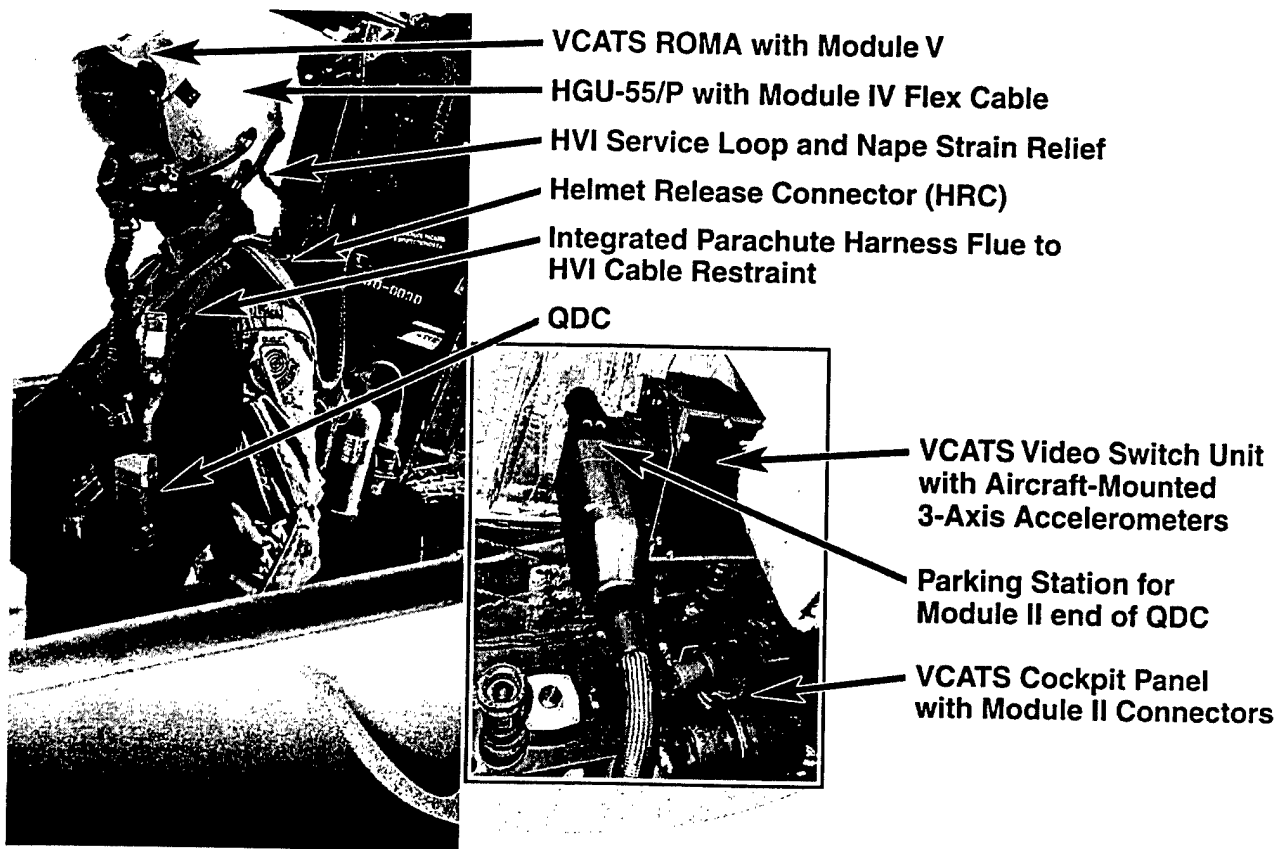

FIGURE 3
Actual Implementation in F-15C Cockpit

DETAILED DESCRIPTION

Module I

The Module I portion of the HVI is usually, but not always, constructed by the airframe or military vehicle manufacturer. Its primary function is to transport the tracker and display signals between the helmet and its associated avionics in a manner that prevents signal degradation or radiated interference and insure that the interface control requirements imposed by the cockpit panel mounted connector and the HMT/D signal interface standard are met. Perhaps the key standardization element for the HVI should be the panel mounted connector that terminates the Module I cable on the cockpit side. Maximum system flexibility could be achieved by configuring this "standard" connector for all potential growth options, even if they are not currently provided. This would allow any helmet system manufacturer to build to the interconnect standard imposed by this connector, while utilizing only the signals and pins needed for the HMT/D system being installed and operated. A single standardized cockpit panel connector that supports both monocular and binocular HMT/D systems using either CRT or flat-panel

image sources and PNVG-HUDs with video record capability has yet to be developed and has been the topic of recent USAF and USN technical coordination meetings. Most other attributes of Module I are usually military vehicle specific and will not be discussed further in this report.

Module II

Module II supports the helmet-to-aircraft interconnect between the lower half of the QDC and the cockpit panel connector. The entire assembly is covered with a DuPont-developed arimid fiber braided shield whose individual strands are nickel/copper plated to make them conductive. Key improvements supplied by the new plated arimid shield include superior flexibility and immunity to work hardening caused by helmet-cable flexure, much lighter weight per unit length than metal braids, and a much lower tendency to expose EMI apertures during cable flexure. Module II contains the lanyard release mechanism that aids autonomous separation of the QDC during ground egress and ejection. The length of this module and its associated lanyard are critical as they simultaneously control the amount of ejection seat travel (i.e., seat velocity at QDC separation), thus ultimately controlling separation forces, as well as accommodating ejection seat travel and pilot movement. The forces exerted on the parachute harness and QDC are dependent upon the type of ejection seat rocket motor propellant used. For the USAF ASCIS II seat, the propellant is back-pressure sensitive, so that pilot/seat acceleration remains relatively constant with variations in pilot weight.

Torso Mounted Quick-Disconnect Connector (QDC)

With respect to operator safety, the most critical unit in the HVI is the torso-mounted high voltage QDC. The QDC forms the interface between Modules II and III and is the pilot's everyday interconnect between the HMT/D and the aircraft (see Figure 4). In the aircraft, the QDC is mounted on a modified CRU-60 (MCRU-60) bracket attached to the pilot harness on the left-hand side. This device was developed jointly with the USN, Naval Air Warfare Center (NAWC), Warminster PA. The MCRU-60

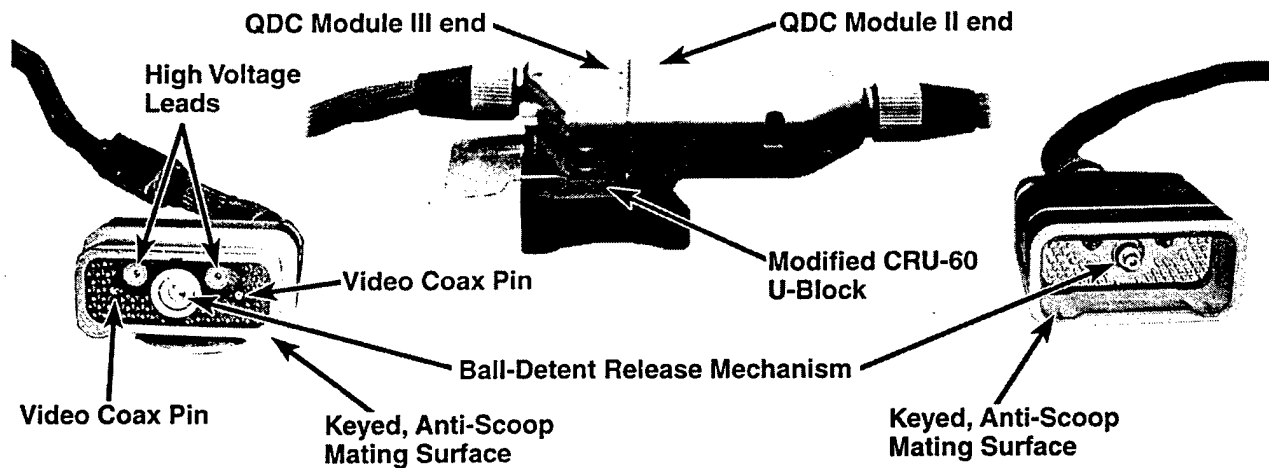

FIGURE 4
Module II & III Sides of QDC Shown Mated and Positioned in MCRU-60

includes a non-jammable U-block mounting scheme for the QDC instead of the normal CRU-60 V-block, which is susceptible to jamming (see Figure 5). It mates and de-mates with power "on" without producing any external sparks or internal damage. The QDC separates automatically without pilot

intervention when the pilot gets up for a rapid ground egress from the cockpit or when the seat moves up its rails during a seat ejection. It transports electrical power, video signals, control signals and position and orientation signals of the HMT to and from the helmet and cockpit control panel (CCP) located on the left-side panel of the cockpit. Under normal situations the QDC is mated or de-mated manually when the power is off. The aircraft side of the QDC can be stored in a parking station that is essentially the top portion of the QDC located above the left cockpit control panel, which serves to protect the connector from the ambient environment when it is not in use (see Figure 3). The QDC can be released easily with the pilot's gloved hand using the perforated stainless steel release plate. The perforations prevent windblast loads from causing the upper portion of the QDC to release during ejection. The centerhole between the two U-block screws shown in Figure 5 contains a powerful miniature magnet. This magnet activates a Hall-effect sensor located in the center of the QDC U-block mounting adapter as shown in Figure 6. This arrangement provides a safety interlock that prevents the HMT/D system from operating if the QDC is not properly seated. The intent is to force the pilot to check the seating during aircraft preflight checks, as proper seating of the QDC is what prevents HVI cable loads during ejection and cable separation from being transferred to the pilot's head and neck.

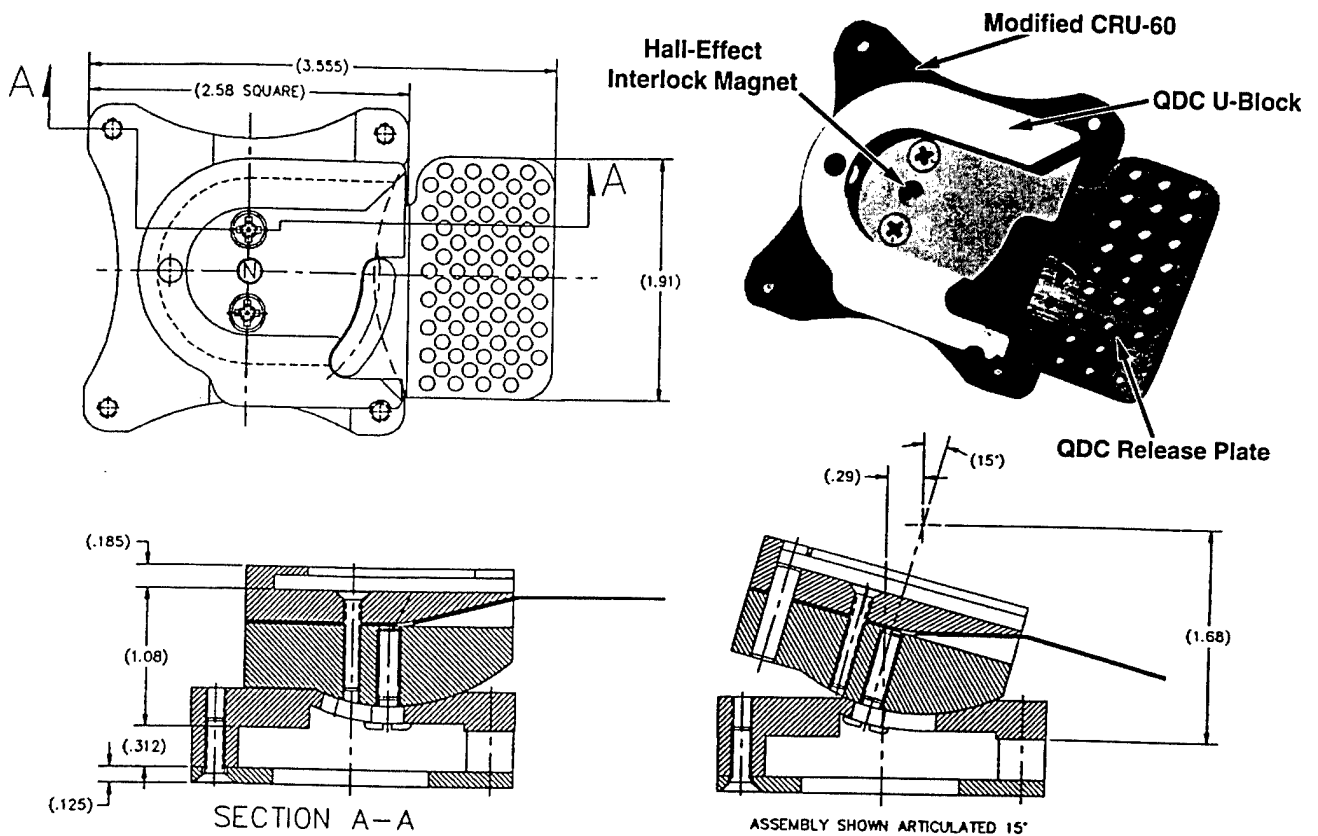

FIGURE 5

Modified CRU-60 (MCRU-60) Parachute Harness Mount with U-Block and Articulating Assembly

The VCATS QDC has a maximum cross sectional opening of approximately 2.6 inches in width by 1.3 inches in thickness and a mated length of about 5.1 inches (see Figure 6). Additionally, it contains circuitry to support the transmission of CRT and HMT EEPROM characterization data to and from the helmet.

The QDC mates with a linear force of 40 to 55 lbs and de-mates by pushing a button with one's thumb under normal situations, or with a linear pull of 20 to 25 lb on the cable strength member or lanyard, during emergency ground-egress situations. The QDC mate/de-mate performance was tested for safety extensively at the NAWC, Warminster ejection tower facility and with mechanical dynamic load instrumentation located at RII.

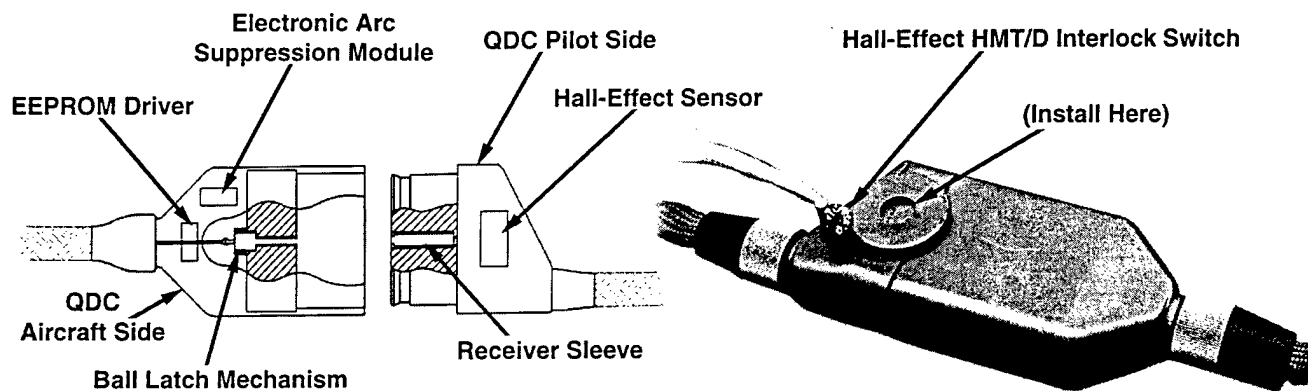

FIGURE 6
QDC Schematic and Actual VCATS QDC with Hall-Effect Circuitry Shown

During de-mating, the top half of the QDC stays firmly connected to the CRU 60 mounting bracket. The force applied to the QDC during de-mate is limited to the bottom half of the QDC, the strength member of the Module II cable, and the MCRU-60 bracket that is firmly attached to the pilot's harness. The pull force during de-mate is not transmitted to the cable between the top part of the QDC and the helmet. This important safety design feature eliminates any pull on the helmet or head/neck of the pilot during an automatic QDC separation in a rapid emergency ground egress or seat ejection.

The QDC is built to separate reliably under axial loads that can vary $\pm 15^\circ$ from a nominal in-line configuration. This corresponded well with torso and airframe mounting locations for the QDC and Module II lanyard based upon initial aircraft surveys. However, late in the VCATS program, the airframe manufacturer directed a significant change in the allowed lanyard mounting location, shifting it to the outboard portion of the left side console in the aircraft cockpit. In this new location, worst-case angles between the QDC and lanyard pull force vector could increase to angles slightly above 25° . To accommodate this larger angle, the MCRU-60/U-block was modified to include 15° of articulation (see Figure 5) to increase the safe angle to at least 30° . A negative aspect of this modification is that the height of the MCRU-60 above the parachute harness strap, and thus the QDC itself, is increased by more than a half inch. As a further boost to safety in this area, the JHMCS program has been considering adding an additional in-line connector between the QDC and airframe cockpit to provide redundant single-use separation in case unforeseen conditions arise that cause the QDC to jam during separation.

Two versions of the QDC have been built and tested to date. The first version used in the binocular QDC solved the arcing problem by including the patented RII mechanical "circuit breaker" for the high voltage leads to contain the arcing within a hermetically sealed metal bellows filled with an electronegative gas at high pressure and an electronic crowbar circuit that shut off the high-voltage power supply and drained residual charge in any electronic charge storage elements prior to complete disengagement of the QDC's pins. The mechanical circuit breakers were a significant contributor to the overall size of the QDC. During testing of this first version it was found that the high-voltage electronic

crowbars integrated into many vendor's high-voltage power supplies are extremely reliable and quick acting. Thus, in the much smaller version of the QDC built for VCATS, only the electronic crowbar circuit is included. The operation of the electronic crowbar is "tuned" by the design and operation of the short pins in the QDC and UC. These pins effectively trigger and set a time interval within which the high voltage must be clamped to a sufficiently low level that arcing cannot occur when these connectors are separated under active load conditions. A smaller electronic version of the mechanical circuit breaker has since been developed that can be installed in the backshell of the Module II side of the QDC should dual redundancy operation for arc-suppression become a requirement.

Module III

Module III supports the helmet-to-aircraft interconnect between the upper half of the QDC and the helmet nape strain relief that transitions the cable to a printed circuit flex-cable format inside the helmet (see Figures 2, 3, and 7). In addition to supporting crew escape functions for ground egress and inflight ejection, Module III incorporates a helmet release connector (HRC) that supports helmet separation should helmet loss also occur during an ejection sequence. To keep the HRC as small as possible, coaxial feedthroughs for the helmet camera and CRT cathode drive are not currently provided in this connector. This does not present a problem for the F-15C's ~6 megaHertz signal bandwidth. For helmet display video applications that require 30 megaHertz or more of video bandwidth and require an HRC, coaxial feedthroughs may be an absolute requirement. Module III also affects head mobility. To promote maximum flexibility and electromagnetic interference (EMI) shielding, the cable wires are organized into mini-bundles and a wrapping/winding technique is employed to provide maximum flexibility for the radii encountered during head rotation and neck flexure. To accommodate the Module III cable and the QDC on the pilot's left side as part of the VCATS OUE, the USAF, Air Combat Command authorized the movement of the parachute lowering device (PLD) from its normal left side mounting location near the Koch fitting (see Figure 7) to a right-side location. In its place, a custom flue has been added that seals around the Module III cable on the underside of the parachute harness to keep the cable in place during normal use or during crew escape operations.

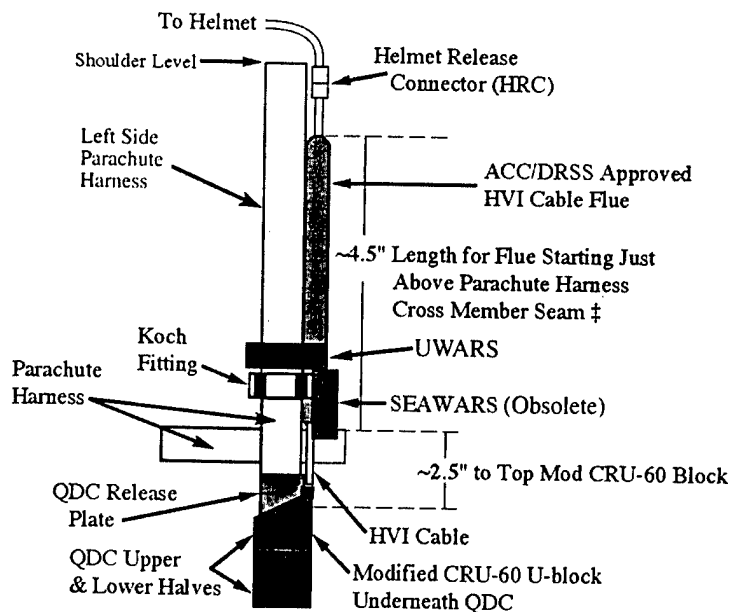

FIGURE 7
Interface Of Module III and QDC with F-15 Parachute Harness

Module IV

Module IV provides a lightweight flex cable interconnect between the Module III wire bundle and the HVI universal connector (UC) receptacle-end located on the front of the helmet (see Figures 2 and 3). Module IV incorporates a multi-layer flex system using alternate sides of the helmet to run signals to the UC. This approach helps improve noise immunity for sensitive signals (see Figure 8). Discrete wire runs for the CRT high voltage anode and focus are used to improve shock hazard safety. To provide enhanced AC magnetic HMT performance and support VCATS OUE test objectives, the Module IV flex incorporates printed circuit mounting locations for magnetic tracker preamps that boost the very low voltage tracker sensor signal levels before they are transmitted down the cable to the IHUD SDP and three-axis accelerometers intended to support the development of biodynamic interference suppression algorithms. Special flex trace shielding keeps impedances matched and provides shielding while minimizing moving metal issues for the magnetic HMT. In the current version of VCATS, signal-to-noise performance for the HMT is typically 10-15 db better than the best previous performance we have measured. The incorporation of this signal conduit technique into the standard flight helmet required that the flex cable assembly be protected from normal abuse without reducing the pilot population head size that a given helmet shell size could accommodate. To meet these requirements, a new endoliner and energy absorbing (EA) liner combination was developed jointly with Gentex and RII to protect the pilot and flex cable while maintaining the same pilot population size for each size of HGU-55/P helmet. The endoliner is a stiff custom-molded shell approximately 20 thousandths of an inch thick that follows the contours of the Module IV flex and universal connector (UC) and seals them off from the pilot and internal helmet environment. To accommodate intrusions into the helmet that vary from 40 up to 200 thousandths of an inch near the UC, a new EA liner was developed using a higher density foam to

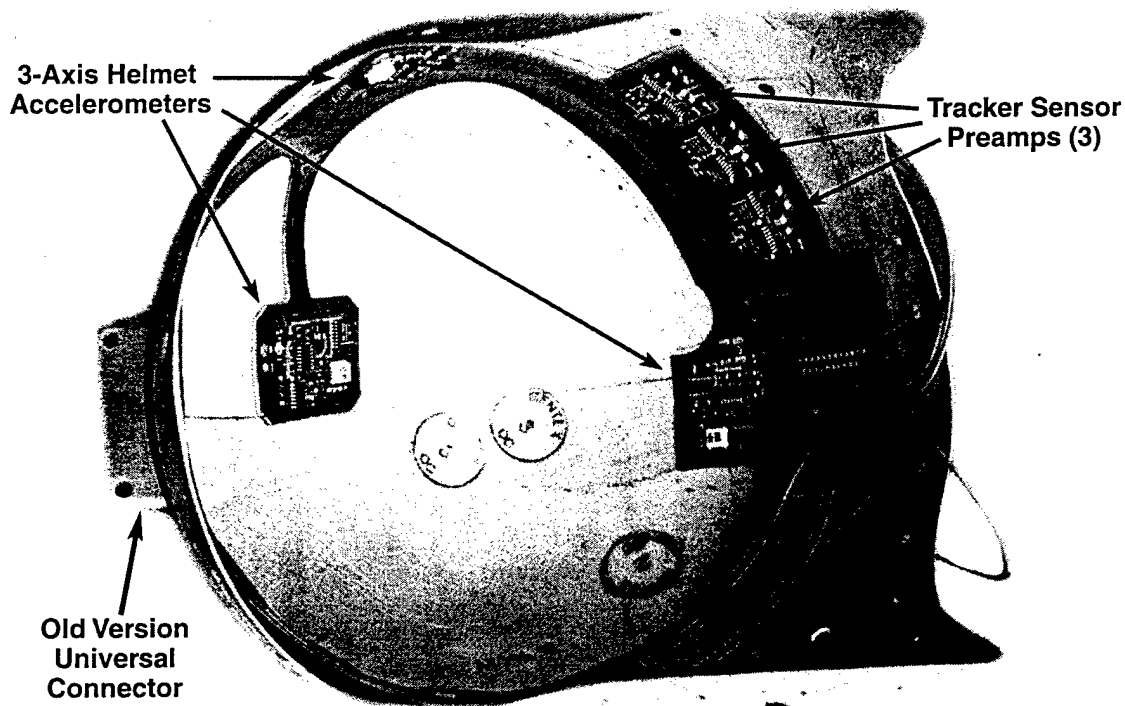

FIGURE 8
Module IV Flex Cable Shown Installed in HGU-55/P Lightweight Helmet Shell

maintain impact protection performance. Standard military helmet impact and penetration tests have shown that, though this liner has been made significantly thinner than the current EA liner in a few small areas, it provides the same or better protection.

Universal Connector (UC)

The Universal Connector (UC) was developed to permit different types of helmet displays and night vision goggle systems to be interchanged on the helmet during inflight operations. The goal was to demonstrate that this new technology for USAF fighters could be designed to bridge the day-night boundary seamlessly for combat operations. Its development has been an unintentional two-step process. The first version was developed for the initial VCATS HMT/D system and was also expected to support the PNVG. However, problems with mating and de-mating the universal connector, poor electrical contact of some pins, signal noise problems caused by poor allocation of signals and inadequate pin separation, flex cable breakage, and the release mechanism's sensitivity to damage made a redesign necessary. The new version of the UC now built by RII (see Figure 9) is designed to correct the deficiencies noted with the first version. The new connector replaces the T-bar assembly with a more robust U-bar handle that seats solidly when the removable optics and mechanical assembly (ROMA) is mated to the helmet and reduces the number of moving parts. Back loading of the latching mechanism has been eliminated so that the pilot can reliably attach the assembly through the rotating-cam mechanism of the new connector. The new UC incorporates shielded backshell provisions that could be necessary for harsh EMI environments and permits the replacement of the Module IV and V flex cables without replacing the UC. The sensitive magnetic HMT signals are well-isolated physically from electrically noisy helmet camera and CRT signals. The CRT and camera video are now fed through the UC using coaxial contacts. The physical dimensions of the Module V portion of the connector are 1.6 inches in height by 2.3 inches in width. The physical dimensions of the Module

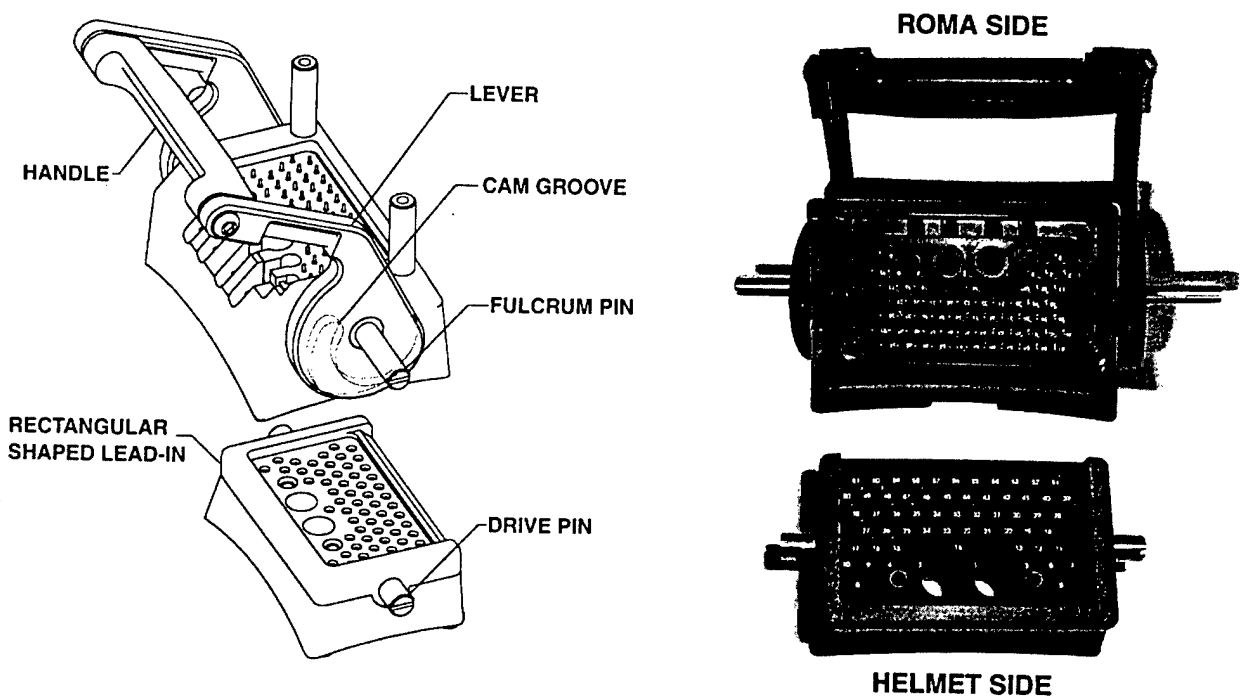

FIGURE 9
Universal Connector Installed in HGU-55/P Lightweight Helmet Shell

IV portion of the connector are approximately 1.3 inches in height by 2.0 inches in width. For safety reasons, the intrusion of the Module IV portion of the UC into the lightweight HGU-55/P helmet has carefully controlled tolerances. It is currently specified as a maximum of 0.180, +0.020 and -0.010 inches. This version of the UC will be used with both the VCATS extended-uplook HMT/D and the PNVG-HUD Module VI.

Module V

Module V incorporates a lightweight multi-layer flex cable, similar to that used in Module IV, to interconnect (Figure 10) the HMT/D tracker sensor and its characterization EEPROM, CRT and its characterization EEPROM, and miniature camera components with the plug-end of the HVI universal connector (UC) located within the ROMA housing. To improve the magnetic tracker performance, separate four turns-per-inch 38-gauge wire leads are used for each of the three tracker sensor coil interconnects to the UC. The ROMA UC is designed to support the PNVG-HUD interconnect and allows rapid interchange or replacement of the helmet modules. The PNVG version of the flex cable interconnect is, of course, not an exact replica of that used for the HMT/D but implements the interface with both common connectors and allocation of like signals.

Module V utilizes a low-weight CRT connector interface using the RII microAVCON (mAVCON) CRT connectors. The mAVCON provides a standardized pinout that all vendors can design around and be sure that their product can be operated with systems using this connector. The receptacle housing the deflection yoke and anode leads also holds the CRT characterization EEPROM. Electronics designed to drive miniature CRTs with the mAVCON connector are also able to read the EEPROM data and automatically adjust their internal anode and control grid voltages, deflection drive, and video drive for maximum performance with a particular CRT. Using the mAVCON and a CRT pin-straightener, a failed CRT can be replaced in about four minutes using a

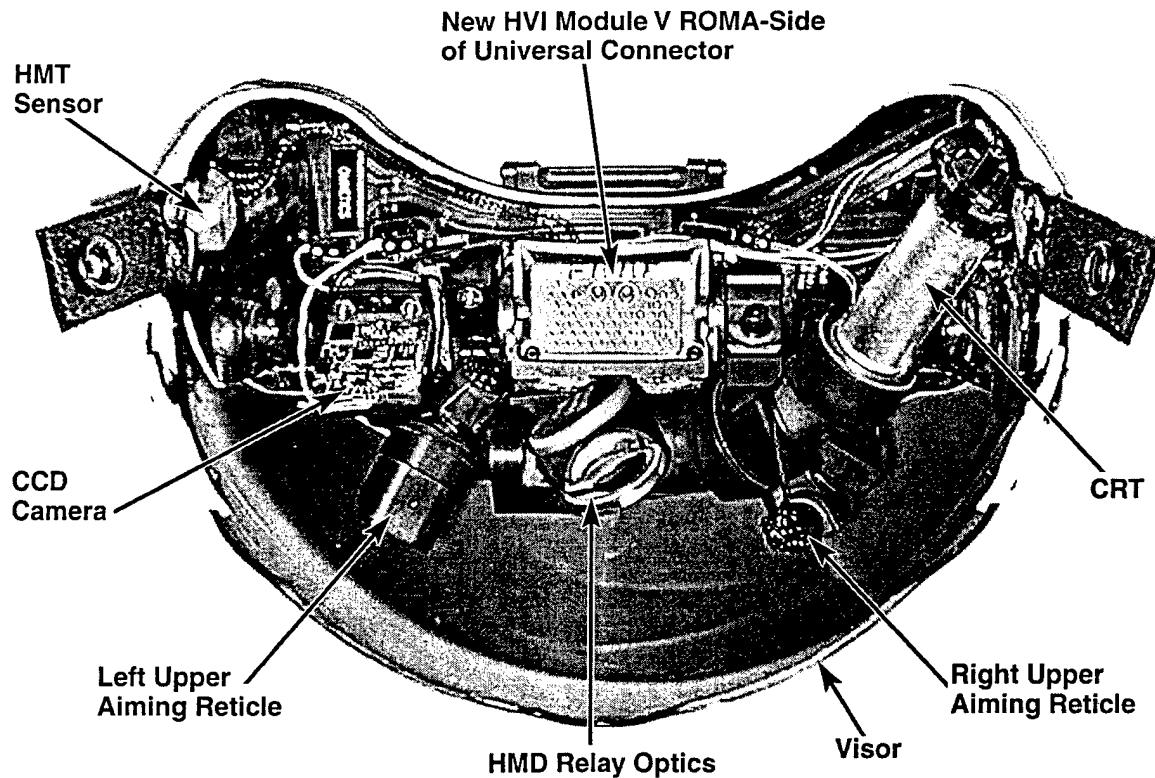

FIGURE 10
Module V Flex Shown Mounted in ROMA with HMT/D Helmet Components

simple screwdriver. When power is reapplied the electronics automatically adjust for the requirements of the new CRT. The mAVCON design helps to minimize change-out time for the CRT to support squadron PE shop requirements and operational activities like tactical combat turns (TCTs). Several major vendors of miniature CRTs in the United States and United Kingdom are adopting the mAVCON connector interface as an off-the-shelf option. The version of the VCATS helmet shown in Figure 10, designated as the "extended-uplook" version, also shows the upper aiming reticles that extends the pilot's cueing capability in a high-G air combat engagement by approximately 45°.

CRT Interconnect Considerations

There are many design and interface issues surrounding the interface of the HMT/D to the remote electronics that form the bulk of the hardware for either a visually coupled or virtual reality system. One of the primary issues, if not the key issue, is how the system design is implemented for sending and receiving signals to and from the head-mounted components. It is particularly important for signals that create the visual scene imagery. There are two major interface issues that significantly affect the performance of the head-mounted image source that must drive the display optics. One is the remoteness of the image source from its drive electronics. This remoteness contributes to image source bandwidth limitations and noise characteristics, especially for CRT-based systems. Secondly, the head-mounted image source is viewed under significant magnification by the head-mounted optics. Thus, any display artifacts are much more obvious than they would be for panel-mounted displays. These factors make the CRT image source and its interconnect between the head-mounted components and their supporting electronics a key integration issue.

"Hot Tube" CRT

Helmet display design over the past 29 years has been characterized by a process of ad hoc system development using components such as the CRT image source off-the-shelf and attempting to "design around" performance limitations imposed by such a component selection and design approach. At the initiation of the VCATS HVI development, it was clear that CRT performance had to be optimized to improve display contrast and see-through performance using the standard Air Force helmet visor. The current "1/2 inch" CRT, which really has a useful display diameter (format size) of ~11.5 millimeters (mm) and outside diameter of approximately 18.5 mm (~3/4 inch), was developed primarily for night vision goggle HUD applications. Its format size, performance and required life characteristics for the high luminance day HMT/D application significantly limit the helmet display optical design option space.

The "Hot Tube" CRT represents a major improvement in packaging and performance. It enlarges the format size to 18 mm while increasing the outside diameter to just 22 mm. The larger format eases optical requirements by permitting better aberration correction with optical elements that can be lighter in weight. A newly developed stator core yoke (developed by Syntronics Instruments) optimizes inductance, capacitance, and producibility. The new yoke also lets the CRT run cooler while providing improved electron beam spot size over the entire scanned area. Space charge effects (the tendency of an electron beam's negative particles to resist dense spacing) are greatly reduced by moving from the normal 8.5 kilovolt anode potential to 11.5 to 13.0 kilovolts. The phosphor, electron gun design, gettering (techniques used to maintain the internal vacuum of CRT), cathode, and the CRT's exterior glass envelop have also been improved and/or optimized to provide much better resolution, contrast, and luminance. Luminance levels of >12,000 ft-Lamberts are now routinely achieved with spot sizes of ~1 mil. New packaging techniques combined with the advantages that the aforementioned AVCON connector allow potting, a major contributor to the weight of conventional miniature CRTs, to be minimized. Taken together these improvements have allowed pilot see-through to be improved on the helmet visor transparency and allowed a no-patch visor display to be achieved in VCATS that is acceptable to fighter pilots.

Associated HVI Electronics

In the past, many military and non-military HMT/D applications have purported to drive the display with high line rates and pixel rates. Such performance was never realized at the display optics because the CRT was being driven through a long unterminated cable with significant distributed capacitance. Effectively, the cable operated as a low-pass filter of the video information. In the HVI, the electronics, CRT, and cable are treated as a system. Video and deflection hybrid integrated circuits were developed with Logicon Technical Services, Inc. as part of the HVI to improve signal transmission performance and eliminate the bulk, weight, and power dissipation at the head imposed by past head-mounted solutions to this problem. The video processor, video amplifier, and deflection hybrids include dies from Analog Devices, Precision Monolithics, Motorola, Supertex, National Semiconductor, and International Rectifier. The dies are incorporated into complete hybrid circuits using militarized packaging developed by MS Kennedy (MSK). The hybrids give the HVI concept a set of standardized electronic building blocks that are low risk and high performance. Used in conjunction with improved cabling, the hybrids can support video bandwidths of greater than 100 MHz that are observable at the CRT faceplate. Maximum video bandwidths (110-130 MHz) can be achieved by placing the video amplifier hybrid in the back shell of the HVI QDC (Figure 2).

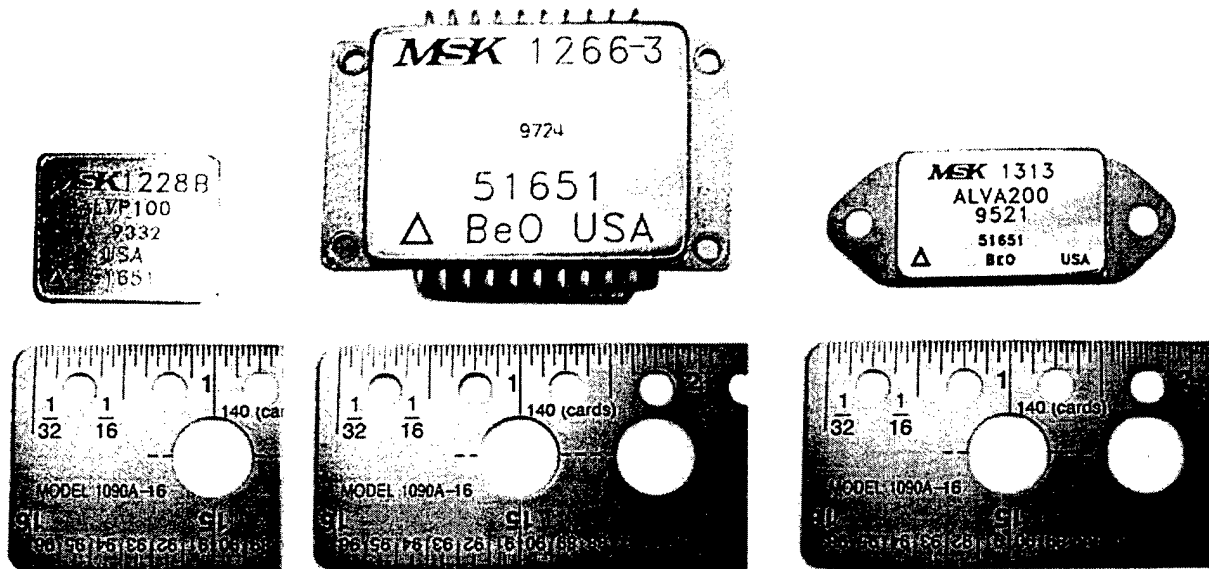

FIGURE 11
VCATS Version of HVI Hybrid Electronics

Video Amplifier Hybrids

The militarized versions of the video hybrids consist of a video processor (MSK# 1228B) and a video amplifier (MSK# MSK1227B or MSK1313B(VCATS)). The video processor hybrid offers a compact and cost effective package of video control functions. It is comprised of circuits that provide low-level video signal gain, contrast adjustment, blanking, black level clamp, and DC bias. It is most useful when both video and stroke symbology or both simultaneously will be presented on the HMD. The video processor hybrid was not used in VCATS because of its primary emphasis on stroke symbology, control panel volume limitations in the F-15C and contractor preferences.

The militarized version of the video amplifier hybrid is designed to provide cathode video modulation, grid-1 (G1) DC bias for brightness control, phosphor protection, and over-temperature protection. In the VCATS version of the video hybrid shown in the figure 12-block diagram, G1 brightness control was dropped because of contractor preferences and phosphor protection was implemented elsewhere in the contractor's circuitry. Cathode video drive was selected over differential drive because differential drive affects the G1/G2 crossover point setting of the CRT, leading to undesirable spot size modulation, and differential drive circuits are susceptible to group delay problems for different frequencies that can become significant at higher video frequencies. Figure 13 shows the 3-db frequency response of ~105.1 megaHertz obtained for a 50-volt peak-peak output voltage swing driving five feet of Raychem Cheminax #9530H1014 95-ohm coaxial cable and a simulated CRT load of 6.5 picoFarads when measured using a Hewlett-Packard 3577B network analyzer.

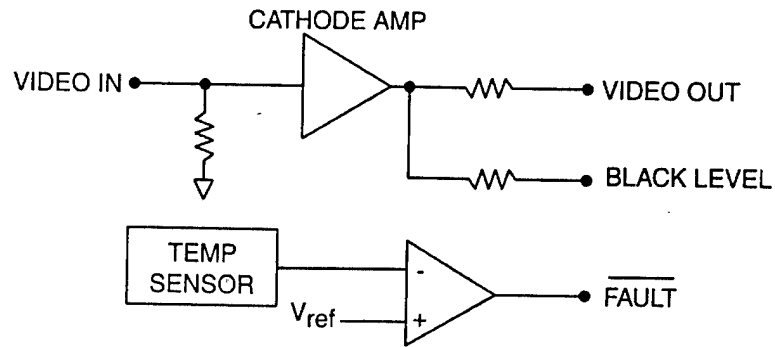

FIGURE 12
Simplified Block Diagram of MSK 1313B Video Amplifier Hybrid

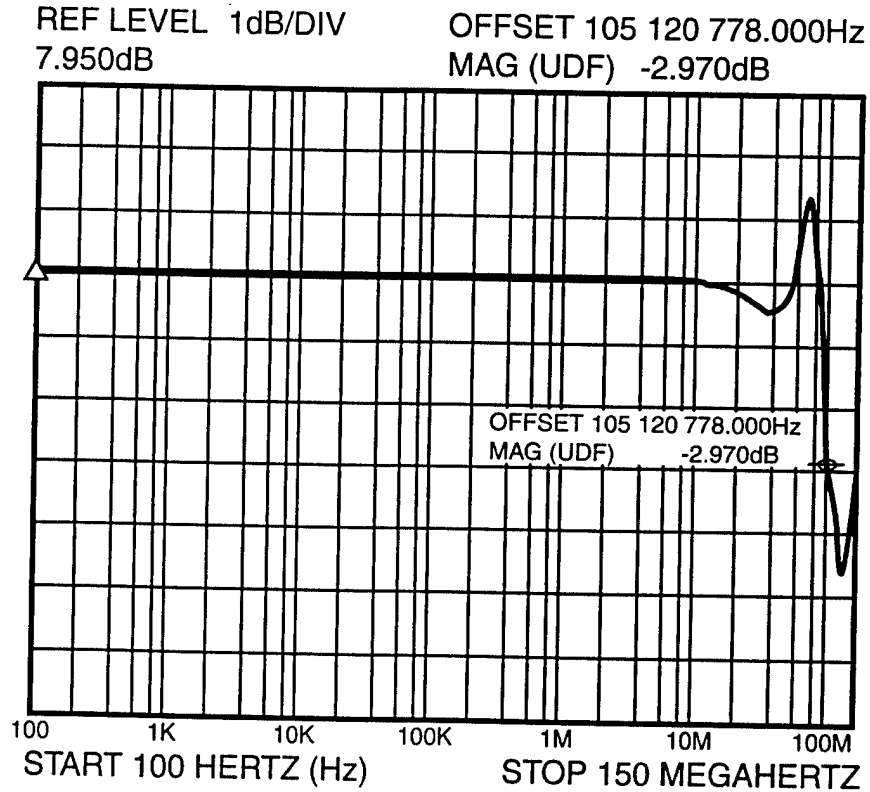
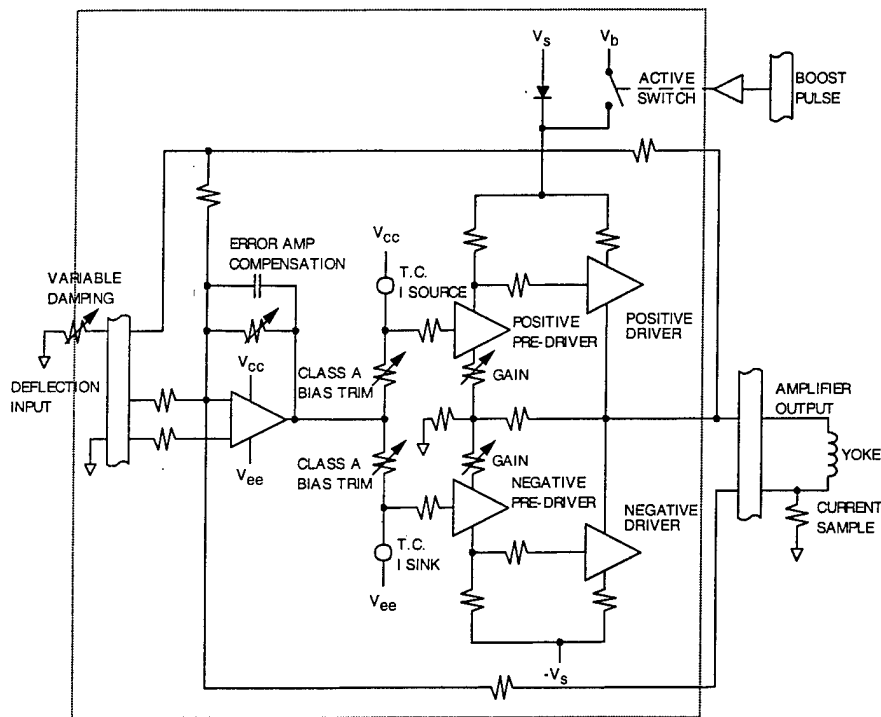

FIGURE 13
VCATS Video Amplifier 3-db Full Signal Bandwidth

Deflection Amplifier Hybrid

The militarized version of the deflection hybrid (MSK# 1266B(VCATS) or 1266-3), as shown in the Figure 14 block diagram, is designed to provide enhanced deflection amplifier performance and power dissipation in a minimal package footprint. The circuit topology consists of a Class A/B linear amplifier with power saving switchmode boost circuit that permits the amplifier to provide rapid retrace capability during the raster scan blanking interval. The dual-mode design is based upon the linear deflection requirement for both raster scan and the stroke write operations. The voltage boost circuit is activated by an applied boost pulse to provide rapid retrace capability. Two feedback loops are included to control overall amplifier response. First-order or positional feedback provides the necessary deflection waveform control during linear scan periods. Second-order or velocity feedback provides the necessary deflection waveform control during transitory periods. The velocity feedback or variable damping may be adjusted by a single resistor value external to the hybrid package to provide underdamped, critically damped, or overdamped amplifier response. The variable elements shown within the amplifier hybrid as diagrammed in Figure 14 can be adjusted or trimmed to optimize amplifier response and stability for different cable/CRT load impedances and changes to the power supply rail voltages. Figure 15 shows the small signal frequency response measured for the VCATS system driving the 90-uHenry stator core yoke interconnected by coaxial shielded runs and helmet flex cable with a rail voltage of 18 volts. For the VCATS application and its HVI configuration, a 3-db system bandwidth of 480 kiloHertz was achieved, which is more than sufficient. Using a higher rail voltage of 32 volts driving twisted pair and the same stator core yoke over the same cable distances, -3-db bandwidths well in excess of 800 kiloHertz have been achieved.



— Deflection Hybrid

FIGURE 14
Deflection Hybrid Functional Block Diagram

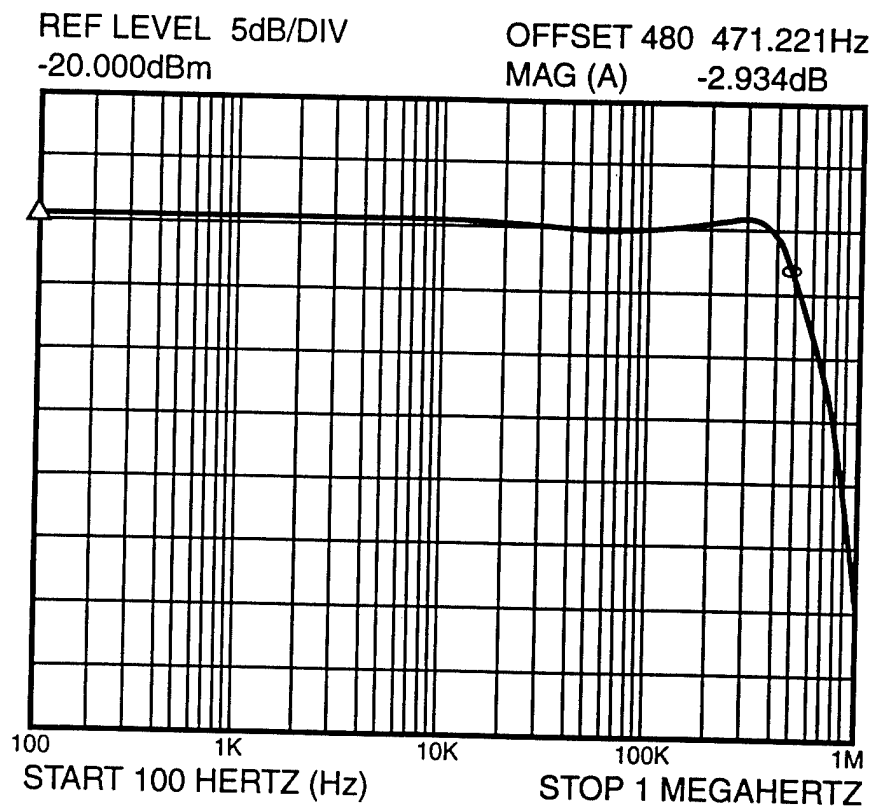

FIGURE 15
Small Signal Frequency Sweep for Deflection Amplifier Hybrid

Summary

This report has discussed the most significant effort now underway within DOD to provide helmet mounted systems with the safety, interconnect flexibility, and performance benefits provided by the development of a standard interface. Table 1 provides a complete summary of the HVI components and their operational characteristics.

The recent availability of a more robust helmet-to-aircraft interface that offers the possibility of standardizing the helmet systems interface, as demonstrated by the VCATS program, is accelerating the introduction and use of HMT/D technology because it lowers risk, improves system life-cycle costs, and provides predictable system growth options. It is also recognized that commercial systems may standardize on flat-panel displays or other types of image source with different requirements. The expanding use of thin film transistor technology may allow the addition of huge amounts of computational power right next to the flat-panel display. Digital High Definition TV is just getting started and will likely have a big impact on helmet display and virtual reality systems. These and other related developments will come together sooner if interface standards can be agreed upon and implemented in conjunction with technology advancements. Currently plans are being discussed jointly with the US Navy to expand the improved version of the HVI to encompass a binocular display system with dual-channel camera record that would incorporate a modified QDC, UC, and harness system using the same production criteria as the current VCATS system. This version will address flat panel display image source requirements and also pursue the development of a standardized cockpit panel connector that can support the variations in helmet display technology that are anticipated for future military vehicles as well as retrofits into what is current in the military inventory.

TABLE 1
Characteristics of Government-Initiated "Standardized"
Helmet-Vehicle Interface (HVI)

COMPONENT	PRIMARY FEATURES & PERFORMANCE	OTHER FEATURES
CRT Connector (micro AVCON)	<ul style="list-style-type: none"> - Uses screwdriver and twist-lock connector to change head-mounted CRTs when they fail or age - *Operates to 70,000 foot altitude from -55° to 125° Centigrade in high humidity and explosive vapor environments 	<ul style="list-style-type: none"> - Standardized pin out - Improved CRT yield - Eliminates need to scrap cable harness when CRT fails - Lighter than comparable hard-wired CRT connections - Provides standard mount for CRT characterization EEPROM - Helps standardize wire types
CRT Characterization EEPROM	<ul style="list-style-type: none"> - Mounted inside CRT AVCON receptacle - Provides standard format for optimizing each CRT's grid voltages and drive - Same as * 	<ul style="list-style-type: none"> - Holds geometry correction coefficients that can be used by CRT deflection electronics to correct or minimize residual optical distortion - Resolution, luminance, and contrast maximized for helmet display viewing conditions
Display Unit Flexible Printed Circuit Assemblies.	<ul style="list-style-type: none"> - Minimized "B" field shielding - Specialized hybrid construction to maximize low frequency signal handling - Protection Circuitry for CRT EEPROM - Minimizes weight on helmet 	<ul style="list-style-type: none"> - Minimizes eddy current interference with magnetic tracker sensor - Minimizes secondary signal paths for tracker signals improving accuracy - Minimizes effects of static and accidental HV discharges on EEPROMs - Allows the interchange of the ROMA or display units from helmet to helmet with out the need for adjustments - Flex construction is considerably lighter than discrete wiring previously used
Tracker Characterization EEPROM (Optional)	<ul style="list-style-type: none"> - Can be mounted on Module V (Module VI for NVG) flex assembly interface to helmet tracker transducer - Same as * 	<ul style="list-style-type: none"> - Allows easy exchange of different tracker transducers with automatic calibration - Optimizes tracker transducer's characteristics as needed
Tracker Hybrid or ASIC (Optional)	<ul style="list-style-type: none"> - Can be mounted on Module V flex in ROMA (Module VI for NVG) - Same as * 	<ul style="list-style-type: none"> - If tracker transducer's output are low level signals they can be boosted for better cable transmission characteristics - Sensor signal can also be digitized before transmission from the helmet to signal processing electronics
Universal Connector Interface	<ul style="list-style-type: none"> - Allows in-flight replacement of ROMA or display unit to an NVG display for night missions 	<ul style="list-style-type: none"> - Single helmet can support more than one type of display and mission - Allows ROMA to be interchanged with helmet, custom helmet liners, and custom trimmed visors

TABLE 1 (cont)

COMPONENT	PRIMARY FEATURES & PERFORMANCE	OTHER FEATURES
In-Helmet, Flexible Printed Circuit Assemblies	<ul style="list-style-type: none"> - Minimized "B" field shielding - Specialized hybrid construction to maximize low frequency signal handling - Three channels of small signal amplification for tracker sensor - Three axes of accelerometers and support electronics - Separate routing of high and low level signals - Minimizes weight on helmet 	<ul style="list-style-type: none"> - Minimizes eddy current interference with magnetic tracker sensor - Minimizes secondary signal paths for tracker signals improving accuracy - Provides noise immunity for low level tracker signals - Forms part of biodynamic feedback filter - Minimizes crosstalk between high level and low level (sensitive) signals - Flex construction is considerably lighter than discrete wiring previously used
Helmet Release Connector	<ul style="list-style-type: none"> - Automatic release of the Helmet from umbilical in the event of loss on ejection 	<ul style="list-style-type: none"> - Tamper proof design, prevents inadvertent release of connector
Advanced Metalized Fiber Shielding.	<ul style="list-style-type: none"> - Metalized Kevlar fiber construction - High EMI window coverage, better than 95% 	<ul style="list-style-type: none"> - Lightweight and highly durable - Allows for greater electro-magnetic interference (EMI) reliability - Doesn't work-harden with flexure as a metal shield does
High-Voltage QDC	<ul style="list-style-type: none"> - Operates to 15,000 volts and up to 70,000 foot altitude in high humidity and explosive environment - Composite construction to minimize weight and volume 	<ul style="list-style-type: none"> - Provides safe and standardized mating and de-mating interface for the HMT/D - Minimizes interference with normal pilot motion - Can include electronic circuit breaker in backshell if dual redundant operation is required
CRT Electronic Crowbar	<ul style="list-style-type: none"> - Uses spark gaps and custom electronics to crowbar CRT high-voltage power in less than 30 usec without premature "turn-off" - Same as * 	<ul style="list-style-type: none"> - Provides safe and standardized backup for QDC should it fail - Solid-state version is in development
Electronic Crowbar Compatible High Voltage Power Supply	<ul style="list-style-type: none"> - Anode supply ripple and noise $\leq 0.05\%$ and regulation $\leq 0.5\%$ - All other grid voltage supplies have ripple and noise $\leq 0.05\%$ and regulation $\leq 0.1\%$ - Same as * 	<ul style="list-style-type: none"> - Provides programmable supplies whose values can be controlled automatically by CRT characterization EEPROMS - Helps maximize CRT resolution, luminance, and contrast performance - Reliably interfaced to electronic crowbar
CRT Video Hybrid	<ul style="list-style-type: none"> - Provides equivalent bandwidth of >100 MHz at 50 volts peak-peak of video modulation when driving three feet or less of Chemimax #9530H1014 95 ohm coaxial cable - Same as * 	<ul style="list-style-type: none"> - Provides standard video interface - Reduces discrete component count of electronics - Mounts in either QDC back shell or cockpit panel depending on required video bandwidth

TABLE 1 (cont)

COMPONENT	PRIMARY FEATURES & PERFORMANCE	OTHER FEATURES
CRT Deflection Hybrid	<ul style="list-style-type: none"> - Provides equivalent full power bandwidth of >80 kHz with less than 3 usec settling time to 0.1% when driving 90 uH yoke - Raw small signal bandwidth in excess of 800 kHz - Same as *, except -10° C 	<ul style="list-style-type: none"> - Provides standard high performance deflection interface - Reduces discrete component count of electronics

REFERENCES

- Bapu, P.T., Aulds, J.M., & Fuchs, S.P. (1994). *High Voltage Quick Disconnect Connector and Harness System for USAF Helmet Mounted Displays*. Contract No. 07-014-25S. University of Dayton Research Institute, Dayton OH.
- Clark, Thomas & Hollis, Dale (1994). *Quick Disconnect Connector Assembly Development Program for the Visually Coupled System*, Contract No. R176384. Reynolds Industries, Los Angeles CA.
- Ross, J. A., & Kocian, D. F. (1993). Hybrid Video Amplifier Chip Set for Helmet-Mounted Visually Coupled Systems. *1993 Society for Information Display International Symposium Digest of Technical Papers*, 24, 437-440.
- Ross, J. A., & Kocian, D. F. (1995). Hybrid Deflection Amplifier for Helmet-Mounted Visually Coupled Systems. *1995 Society for Information Display International Symposium Digest of Technical Papers*, A3.4, 44-49.
- Sauerborn, Jack (1995). *Improved Sub-Miniature Cathode Ray Tube*. Contract No. F33615-89-D-0673. Hughes Lexington, Inc., Lexington, KY.
- Task, H. L., & Kocian, D. F. (1994). *Fundamentals and Optics of Helmet-Mounted Displays (SC04) and Design and Integration Issues of Helmet-Mounted Displays (SC05)*, Short courses presented at SPIE's International Symposium on Optical Engineering in Aerospace Sensing, Orlando, FL, 4-8 April, 1994.