

CECW-EH-D Engineer Manual 1110-2-1602	Department of the Army U.S. Army Corps of Engineers Washington, DC 20314-1000	EM 1110-2-1602 15 October 1980
	Engineering and Design HYDRAULIC DESIGN OF RESERVOIR OUTLET WORKS	
	Distribution Restriction Statement Approved for public release; distribution is unlimited.	

REPRODUCTION AUTHORIZATION/RESTRICTIONS

The text of this manual and all illustrative materials therein, which were prepared by government personnel, are public property and therefore not subject to copyright.

All uses in this manual of information from non-governmental sources are in the form of findings or opinions and credit has been given in the text at the point of use through superscript numbers corresponding to the list of references and/or bibliography. Anyone wishing to make further use of any of the non-governmental information referenced, by itself and apart from the context in which herein presented, should seek any necessary permissions direct from such sources.

Since all use in this manual of materials from non-governmental sources has been permissible in nature, and is fully credited, reprint or republication in whole or in part would appear properly subject only to the crediting of this manual, as follows: **** Engineer Manual No. 1110-2-1602, Engineering and Design, Hydraulic Design of Reservoir Outlet Works, 15 October 1980, Department of the Army, Corps of Engineers, U.S.A. ****.

20020613 032

DEPARTMENT OF THE ARMY
Office of the Chief of Engineers
Washington, D.C. 20314

EM 1110-2-1602

DAEN-CWE-HD

Engineer Manual
No. 1110-2-1602

15 October 1980

Engineering and Design
HYDRAULIC DESIGN OF RESERVOIR
OUTLET WORKS

1. Purpose. This manual presents guidance for the hydraulic design analysis of reservoir outlet works facilities. The theory, procedures, and data presented are generally applicable to the design of similar facilities used for other purposes.
2. Applicability. This manual applies to all field operating activities having responsibility for the design of Civil Works projects.
3. General. Studies pertinent to the project functions and their effects on the hydraulic design of outlet works are briefly discussed in this manual. Also where appropriate, special design guidance is given for culverts, storm drains, and other miscellaneous small structures. In this manual, theory is presented only where required to clarify presentation or where the state of the art is limited in textbooks.

FOR THE CHIEF OF ENGINEERS:



FORREST T. GAY III
Colonel, Corps of Engineers
Executive Director, Engineer Staff

This Manual Supersedes EM 1110-2-1602, 1 August 1963.

DAEN-CWE-HD

Engineer Manual
No. 1110-2-1602

15 October 1980

Engineering and Design
HYDRAULIC DESIGN OF RESERVOIR OUTLET WORKS

Table of Contents

	Subject	Paragraph	Page
CHAPTER 1.	INTRODUCTION		
Section I.	General		
	Purpose-----	1-1	1-1
	Applicability-----	1-2	1-1
	References-----	1-3	1-1
	Bibliography-----	1-4	1-2
	Symbols-----	1-5	1-2
	Other Guidance and Design Aids-----	1-6	1-2
	WES Capabilities and Services-----	1-7	1-3
	Design Memorandum Presentations-----	1-8	1-3
	Classification of Conduits-----	1-9	1-3
Section II.	Project Functions and Related Studies		
	General-----	1-10	1-4
CHAPTER 2.	HYDRAULIC THEORY		
Section I.	Introduction		
	General-----	2-1	2-1
	Basic Considerations-----	2-2	2-1
Section II.	Conduits Flowing Partially Full		
	General-----	2-3	2-2
	Discharge Controls for Partially Full Flow-----	2-4	2-2
	Flow Profiles-----	2-5	2-3
Section III.	Conduits Flowing Full		
	General-----	2-6	2-3
	Exit Portal Pressure Grade-Line Location-----	2-7	2-4
Section IV.	Gradients		
	General-----	2-8	2-4
	Hydraulic Grade Line and Energy Grade Line-----	2-9	2-5
	Mean Pressure Computation-----	2-10	2-6

	<u>Subject</u>	<u>Paragraph</u>	<u>Page</u>
Section V.	Energy Losses		
	General-----	2-11	2-7
	Surface Resistance (Friction)-----	2-12	2-7
	Form Resistance-----	2-13	2-15
Section VI.	Cavitation		
	General-----	2-14	2-19
	Theory-----	2-15	2-20
	Design Practice-----	2-16	2-21
	Preventive Measures-----	2-17	2-21
	Boundary Layer-----	2-18	2-22
	Air Demand-----	2-19	2-23
	Air Flow-----	2-20	2-24
CHAPTER 3.	SLUICES FOR CONCRETE GRAVITY DAMS		
Section I.	Basic Considerations		
	Location-----	3-1	3-1
	Size, Shape, and Number-----	3-2	3-1
	Elevation and Alignment-----	3-3	3-1
Section II.	Sluice Intakes		
	General-----	3-4	3-2
	Trash Protection-----	3-5	3-2
	Entrance Curves-----	3-6	3-3
	Intake Energy Losses-----	3-7	3-4
Section III.	Gate Passage, Gates, and Valves		
	General-----	3-8	3-5
	Gate Types-----	3-9	3-5
	Control Valves-----	3-10	3-7
	Metering Devices-----	3-11	3-8
	Gate Passageway Requirements-----	3-12	3-9
	Gate Slots-----	3-13	3-9
	Gate Recess-----	3-14	3-10
	Gate Seats-----	3-15	3-10
	Steel Liners-----	3-16	3-10
	Air Vents-----	3-17	3-10
Section IV.	Sluice Outlet Design		
	General Considerations-----	3-18	3-11
	Exit Portal Constructions-----	3-19	3-12
	Sluice "Eyebrow" Deflectors-----	3-20	3-12

	Subject	Paragraph	Page
CHAPTER 4.	OUTLET FACILITIES FOR EMBANKMENT DAMS		
Section I.	Basic Considerations		
	Approach Channel-----	4-1	4-1
	Conduits and Tunnels for Embankment Dams-----	4-2	4-1
Section II.	Intake and Gate Facilities		
	Intake Structures-----	4-3	4-2
	Intake Tower Versus Central Control Shaft-----	4-4	4-3
	Submerged Intakes-----	4-5	4-4
	Combined Intake and Gate Structure-----	4-6	4-4
	Underground Control Structures-----	4-7	4-5
	Downstream Control Structures-----	4-8	4-5
	Gate Passageway Requirements-----	4-9	4-5
	Low-Flow Releases-----	4-10	4-6
Section III.	Entrance Shapes		
	General-----	4-11	4-6
	Selection of Entrance Shape for Design-----	4-12	4-6
	Linear Sidewall or Pier Flare-----	4-13	4-7
Section IV.	Control Gates		
	General-----	4-14	4-7
	Gate Lip Geometry-----	4-15	4-7
	Vertical-Lift Gate Discharge Computations-----	4-16	4-8
	Commercial Gates-----	4-17	4-8
	Hydraulic Load for Vertical-Lift Gates-----	4-18	4-8
	Vibration of Cable-Suspended Gates-----	4-19	4-9
Section V.	Transitions		
	General-----	4-20	4-12
	Entrance and Intake Transitions-----	4-21	4-12
	In-Line Transitions-----	4-22	4-12
	Exit Transition-----	4-23	4-14
CHAPTER 5.	ENERGY DISSIPATION AND DOWNSTREAM CHANNEL PROTECTION		
Section I.	Energy Dissipators		
	General-----	5-1	5-1
	Hydraulic-Jump Type Stilling Basins-----	5-2	5-1
	Low-Head Structures-----	5-3	5-8

EM 1110-2-1602
1980

	<u>Subject</u>	<u>Paragraph</u>	<u>Page</u>
Section II.	Outlet Channel		
	General-----	5-4	5-9
	Riprap-----	5-5	5-10
	Side-Slope Erosion-----	5-6	5-10
CHAPTER 6.	SELECTIVE WITHDRAWAL STRUCTURES		
	Types-----	6-1	6-1
	Design-----	6-2	6-1
	Flow Regulation-----	6-3	6-4
	Model Investigations-----	6-4	6-4
APPENDIX A.	BIBLIOGRAPHY		
APPENDIX B.	NOTATION		
APPENDIX C.	PLATES		
APPENDIX D.	COMPUTATION OF DISCHARGE RATING CURVES FOR OUTLET WORKS (Illustrative Example)		
APPENDIX E.	COMPUTATION FOR DESIGN OF TRANSITION SECTION (Illustrative Example)		
APPENDIX F.	COMPUTATION FOR DESIGN OF OUTLET WORKS STILLING BASIN (Illustrative Examples)		

CHAPTER 1

INTRODUCTION

Section I. General

1-1. Purpose. This manual presents guidance for the hydraulic design analyses of reservoir outlet works facilities. Although primarily prepared for the design of reservoir outlet works, the theory, procedures, and data presented are generally applicable to the design of similar facilities used for other purposes. Studies pertinent to the project functions and their effects on the hydraulic design of outlet works are briefly discussed. Where appropriate, special design guidance is given for culverts, storm drains, and other miscellaneous small structures. Procedures are generally presented without details of theory since these details can be found in many hydraulic textbooks. However, some basic theory is presented as required to clarify presentation and where the state of the art is limited in textbooks. Both laboratory and prototype experimental test results have been correlated with current theory in the design guidance where possible.

1-2. Applicability. This manual applies to all OCE elements and all field operating activities having responsibilities for the design of civil works projects.

1-3. References.

- a. National Environmental Policy Act (NEPA), PL 9-190, Section 102(2)(c), 1 Jan 1970, 83 Stat 853.
- b. TM 5-820-4, Drainage for Areas Other than Airfields.
- c. ER 1110-1-8100, Laboratory Investigations and Materials Testing.
- d. ER 1110-2-50, Low Level Discharge Facilities for Drawdown of Impoundments.
- e. ER 1110-2-1402, Hydrologic Investigation Requirements for Water Quality Control.
- f. ER 1110-2-2901, Construction Cofferdams.
- g. ER 1110-2-8150, Investigations to Develop Design Criteria for Civil Works Construction Activities.

- h. EM 1110-2-1601, Hydraulic Design of Flood Control Channels (Changes 1-2).
- i. EM 1110-2-1603, Hydraulic Design of Spillways (Change 1).
- j. EM 1110-2-2400, Structural Design of Spillways and Outlet Works.
- k. EM 1110-2-2901, Design of Miscellaneous Structures, Tunnels.
- l. EM 1110-2-2902, Conduits, Culverts & Pipes (Changes 1-2).
- m. EM 1110-2-3600, Reservoir Regulation (Changes 1-3).
- n. Hydraulic Design Criteria (HDC) sheets and charts. Available from: Technical Information Center, U. S. Army Engineer Waterways Experiment Station (WES), P. O. Box 631, Vicksburg, MS 39180.
- o. Conversationally Oriented Real-Time Program Generating System (CORPS) computer programs. Available from: WESLIB, U. S. Army Engineer Waterways Experiment Station, P. O. Box 631, Vicksburg, MS 39180, and from several CE computer systems.

Where the above-listed references and this manual do not agree, the provisions of this manual shall govern.

1-4. Bibliography. Bibliographic items are indicated throughout the manual by numbers (item 1, 2, etc.) that correspond to similarly numbered items in Appendix A. They are available for loan by request to the Technical Information Center Library, U. S. Army Engineer Waterways Experiment Station, P. O. Box 631, Vicksburg, MS 39180.

1-5. Symbols. A list of symbols is included as Appendix B, and as far as practical, agrees with the American Standard Letter Symbols for Hydraulics (item 3).

1-6. Other Guidance and Design Aids. Extensive use has been made of Hydraulic Design Criteria (HDC),ⁿ prepared by WES and OCE. Similarly, data and information from Engineer Regulations and special reports have been freely used. References to Hydraulic Design Criteria are by HDC chart number. Since HDC charts are continuously being revised, the user

should verify that the information used is the most up-to-date guidance. Applicable HDC charts and other illustrations are included in Appendix C to aid the designer. References to specific project designs and model studies are generally used to illustrate the structure type, and the dimensions are not necessarily the recommended dimensions for every new project. The WES Automatic Data Processing Center (ADPC) Computer Program Library (WESLIB) provides time-sharing computer services to CE Divisions and Districts. One such service is the Con conversationally Oriented Real-Time Program-Generating System (CORPS) that especially provides the noncomputer-oriented or noncomputer-expert engineer a set of proven engineering applications programs, which he can access on several different computer systems with little or no training. (See item 54 for instructions on use of the system and a partial list of available programs. Updated lists of programs can be obtained through the CORPS system.) References to available programs that are applicable to the design of reservoir outlet works are noted in this manual by the CORPS program numbers.

1-7. WES Capabilities and Services. WES has capabilities and furnishes services in the fields of hydraulic modeling, analysis, design, and prototype testing. Recently, expertise has been developed in the areas of water quality studies, mathematical modeling, and computer programming. Procedures necessary to arrange for WES participation in hydraulic studies of all types are covered in ER 1110-1-8100.^c WES also has the responsibility for coordinating the Corps of Engineers hydraulic prototype test program. Assistance during planning and making the tests is included in this program. (See ER 1110-2-8150.g)

1-8. Design Memorandum Presentations. General and feature design memoranda should contain sufficient information to assure that the reviewer is able to reach an independent conclusion as to the design adequacy. For convenience, the hydraulic information, factors, studies and logic used to establish such basic outlet works features as type, location, alignment, elevation, size, and discharge should be summarized at the beginning of the hydraulic design section. Basic assumptions, equations, coefficients, alternative designs, consequences of flow exceeding the design flow, etc., should be complete and given in appropriate places in the hydraulic presentation. Operating characteristics and restrictions over the full range of potential discharge should be presented for all release facilities provided.

1-9. Classification of Conduits. Two broad classifications of reservoir outlet works facilities are discussed in this manual: concrete gravity dam and embankment dam facilities. Outlet works through concrete

gravity dams will be called sluices while those through embankment dams will be called conduits and/or tunnels.

a. Concrete Gravity Dams. Generally, sluices that traverse through the masonry of concrete gravity dams have rectangular cross sections and are short in comparison with conduits through embankment dams of comparable height. Use of a number of small sluices, at one or more elevations, provides flexibility in flow regulation and in quality of water released downstream. Sluices are controlled by gates at the upstream face and/or by gates or valves operated from a gallery in the interior of the dam. Sluices are usually designed so that the outflow discharges onto the spillway face and/or directly into the stilling basin. When sluices traverse through nonoverflow sections, a separate energy dissipator must be provided. Arch dams, multiple arch dams, and hollow concrete dams are less common; and although the outlet works design may require special features, the same hydraulic principles are applicable.

b. Embankment Dams. Conduits and/or tunnels for embankment dams may have circular, rectangular, horseshoe, or oblong cross sections and their length is primarily determined by the base width of the embankment. Due to the greater length, it is usually more economical to construct a single large conduit than a number of small conduits. Conduits should be tunneled through the abutment as far from the embankment as practicable, or placed in an open cut through rock in the abutment or on the valley floor. Gates and/or valves in an intake tower in the reservoir, in a central control shaft in the abutment or embankment, or at the outlet portal are used to control the flow. Generally, placement of the control device at the outlet portal should be avoided when the conduit passes through the embankment due to the inherent dangers of a possible rupture of a conduit subject to full reservoir head. Diversion during construction or reservoir evacuation requirements, especially on large streams, may govern the size and elevation of the conduit(s). Foundation conditions at the site may also govern the design. (See EM 1110-2-2901^k and EM 1110-2-2902.¹)

Section II. Project Functions and Related Studies

1-10. General. Project functions and their overall social, environmental, and economic effects greatly influence the hydraulic design of outlet works. Optimization of the outlet works hydraulic design and operation requires an awareness by the designer of the reliability, accuracy, sensitivity, and possible variances of the data used. The ever-increasing importance of environmental considerations requires that the designer maintain close liaison with many disciplines to be sure

environmental and other objectives are satisfied in the design. General project functions and related design considerations are briefly discussed in the following paragraphs.

a. Functions.

(1) Flood Control. Flood control outlets are designed for relatively large capacities where close regulation of flow is less important than are other requirements. Although control of the outflow by gates is usually provided, the conduits may be ungated, in which case the reservoir is low or empty except in time of flood. When large discharges must be released under high heads, the design of gates, water passages, and energy dissipator should be carefully developed. Multilevel release provisions are often necessary for water quality purposes.

(2) Navigation. Reservoirs that store water for subsequent release to downstream navigation usually discharge at lower capacity than flood control reservoirs, but the need for close regulation of the flow is more important. The navigation season often coincides with the season of low rainfall, and close regulation aids in the conservation of water. Outlet works that control discharges for navigation purposes are required to operate continuously over long periods of time. The designer should consider the greater operation and maintenance problems involved in continuous operation.

(3) Irrigation. The gates or valves for controlling irrigation flows are often basically different from those used for flood control due to the necessity for close regulation and conservation of water in arid regions. Irrigation discharge facilities are normally much smaller in size than flood regulation outlets. The irrigation outlet sometimes discharges into a canal or conduit rather than to the original riverbed. These canals or conduits are usually at a higher level than the bed of the stream.

(4) Water Supply. Municipal water supply intakes are sometimes provided in dams built primarily for other purposes. Such problems as future water supply requirements and peak demands for a municipality or industry should be determined in cooperation with engineers representing local interests. Reliability of service and quality of water are of prime importance in water supply problems. Multiple intakes and control mechanisms are often installed to assure reliability, to enable the water to be drawn from any selected reservoir level to obtain water of a desired temperature, and/or to draw from a stratum relatively free from silt or algae or other undesirable contents. Ease of maintenance and

15 Oct 80

repair without interruption of service is of primary importance. An emergency closure gate for priority use by the resident engineer is required for water supply conduits through the dam.

(5) Power. Power penstocks are not within the scope of this manual. However, if reservoir outlets are to be located in the vicinity of the power plants and switchyards, conduit outlets and stilling basins should be designed so as not to cause any undesirable eddies, spray, or wave action that might jeopardize turbine operation. Power tunnels or penstocks may be used for flood control and/or diversion of the stream during construction of the dam and in such cases the discharge capacity may be determined by the principles outlined in this text.

(6) Low-Flow Requirements. Continuous low-flow releases are required at some dams to satisfy environmental objectives, water supply, downstream water rights, etc. To meet these requirements multilevel intakes, skimmer weirs, or other provisions must be incorporated separately or in combination with other functions of the outlet works facility. Special provisions for these purposes have been incorporated in concrete gravity dam nonoverflow sections. Embankment dams with mid-tunnel control shafts also require special considerations for low-flow releases.

(7) Diversion. Flood control outlets may be used for total or partial diversion of the stream from its natural channel during construction of the dam. Such use is especially adaptable for earth dams (see EM 1110-2-2901^k and ER 1110-2-2901^f).

(8) Drawdown. Requirements for low-level discharge facilities for drawdown of impoundments are given in ER 1110-2-50.^d Such facilities may also provide flexibility in future project operation for unanticipated needs, such as major repairs of the structure, environmental controls, or changes in reservoir regulation.

(9) Multiple Purpose. Any number of purposes may be combined in one project. The designer should study carefully the possible economics of combining outlets into a single structure for multiple use.

b. Related Studies.

(1) Environmental. The general philosophy and guidance for preservation, mitigation, and/or enhancement of the natural environment have been set forth (item 96). Many scientific and engineering disciplines are involved in the environmental aspects of hydraulic structures.

15 Oct 80

Some studies influencing the outlet works design are briefly discussed below. Pertinent data from these studies should be presented in the design memorandum. The designer should have a working knowledge of these data and their limitations.

(a) Fish and Wildlife. Outlet works design and operation can maintain, enhance, or damage downstream fish and wildlife. Flow releases not compatible with naturally seasonable stream quantity and quality can drastically change aquatic life. These changes may be beneficial or may be damaging, such as adverse temperatures or chemical composition, or nitrogen supersaturation (item 86). Information from fish and wildlife specialists on the desired stream regimen should be obtained and considered in the design. Downstream wildlife requirements may fix minimum low-flow discharges. The water quality presentation should include summary data on requirements and reference to source studies.

(b) Recreation. Recreation needs including fishing, camping, and swimming facilities, scenic outlooks, etc., should be considered in the design of energy dissipators and exit channels. These requirements are usually formulated by the planning discipline in cooperation with local interests. To accomplish the desired objectives, close cooperation between the hydraulic and planning engineers is required. Special consideration should be given to facilities for the handicapped, such as wheelchair ramps to fishing sites below stilling basins. Safety fences for the protection of facilities and the public are important. Appreciable damage to stilling basins has resulted from rocks thrown in by the public. The hydraulic engineer should recognize the need for such things as: (1) nonskid walks and steps with handrails designed to protect the elderly and young children; (2) periodic lowering of reservoir levels and flushing of stagnant pools downstream for vector control (mosquitoes, flies, etc.); (3) elimination of construction scars resulting from borrow pits, blasting, land clearing, etc; and (4) maintenance of relatively constant pool levels for reservoir recreation activities.

(c) Water Quality. An awareness of maintaining and/or enhancing the environment within the past decade has brought into existence a relatively new and expanded art of reservoir hydrodynamics. Until recently, the study of reservoir hydrodynamics has been limited to a few prototype vertical temperature gradients and recognition of the seasonal inversions accompanying the fall surface water cooling. However, environmental considerations of today have necessitated the development of preproject capability for prediction of the expected seasonal reservoir stratification and circulation to permit construction and

15 Oct 80

operation of outlet works designed to meet storage and outflow regimes needed for the reservoir and downstream environment. Reservoir hydrodynamic studies may be done by other than the hydraulic designer (such as the hydrologic engineers) and they would specify the withdrawal requirements (quantity, elevation, etc.). The hydraulic engineer then designs the outlet works to meet these requirements. However, the hydraulic designer furnishes some of the information for the hydrologic studies.

(2) Foundations. In concrete dams, foundation conditions have little if any effect upon the hydraulic design of sluices. However, the hydraulic design of outlet works for embankment dams can be appreciably affected by foundation conditions. The conduit shape and control tower location are usually fixed primarily by foundation, structural, and construction considerations in addition to hydraulic requirements. Energy dissipator and outlet channel designs for either sluices or embankment dam outlets are sometimes influenced by local foundation conditions. Foundation information of interest to the hydraulic designer includes: (a) composition and depth of overburden, (b) quality of underlying rock, and (c) quality of exposed rock. In addition, side-slope stability is of considerable importance in the design of riprap protection. Outflow stage change rates are required for bank stability design. Sufficient foundation data and/or reference to its source should be included or referred to in the hydraulic presentation to substantiate the energy dissipator and exit channel design.

(3) Environmental Impact Statements. Section 102(2)(c) of the National Environmental Policy Act (NEPA)^a requires detail documentation in the project design memoranda on the impact of the planned project on the environment. The hydraulic engineer may be required to cooperate in the preparation of impact statements. An analysis of 234 Corps of Engineers environmental impact statements on various projects is given in IWR Report No. 72-3 (item 122). This report can be used as a guide as to the type of material needed and format to be used in developing the statements. Basic to the environmental statements are studies made to define the preproject and project functions and their effects on the environment. In most cases the effect of each project function must be set forth in detail. A recent publication by Ortoano (item 87) summarizes the concepts involved and presents examples relative to water resources impact assessments. Presentation of the hydraulic design in design memoranda must identify environmental requirements and demonstrate how these are satisfied by the hydraulic facility.

(4) Project Life. Two factors in the life of a project of concern to the hydraulic engineer in the design of outlet works are

15 Oct 80

(a) downstream channel aggradation and degradation, and (b) structural deterioration.

(a) Channel Aggradation and Degradation. In many rivers determination of the dominant factors causing bed shaping action like degradation and aggradation is difficult. Changes in the hydrographic characteristics caused by a dam can result in undesirable changes in the elevation of the riverbed. Degradation, or lowering of the riverbed, immediately downstream of a dam may threaten the integrity of the structure. Removal of all or part of the sediment by the reservoir may induce active erosional attack downstream. Similarly, although the total annual sediment transport capacity of the river will drop significantly, the sediment supply by downstream tributaries will be unaltered and there may be a tendency for the riverbed to rise. This channel aggradation can increase the flood hazards from downstream tributaries and may cause reduction in outlet works allowable releases. Resulting tailwater level changes can also adversely affect the stilling basin performance.

(b) Concrete Deterioration. Excessive invert erosion of outlet structures has occurred where sands, gravel, and construction debris have passed through conduits used for diversion during extended periods of low reservoir stages. Construction of a submerged sill upstream of the intake to trap the debris should be considered where this condition is likely to occur. Special materials or liners may be helpful in preventing invert erosion in extremely cold climates where deterioration of the conduit interior from freezing-and-thawing cycles is possible.

CHAPTER 2

HYDRAULIC THEORY

Section I. Introduction

2-1. General. This section presents hydraulic design theory, available experimental data and coefficients, and discussions of certain special problems related to reservoir outlet works design. Generally, the presentations assume that the design engineer is fully acquainted with the hydraulic theories involved in uniform and gradually varied flow, steady and unsteady flows, energy and momentum principles, and other aspects such as energy losses, cavitation, etc., related to hydraulic design as normally covered in hydraulic handbooks and texts such as those by King and Brater (item 56) and Rouse (items 99 and 101). This manual is presented as guidance in the application of textbook material and as additional information not readily available in general reference material. The theory of flow in conduits from a reservoir is essentially the same for concrete and embankment dams. The application of the theory of flow through conduits is based largely upon empirical coefficients so that the designer must deal with maximum and minimum values as well as averages, depending upon the design objectives. To be conservative, the designer should use maximum loss factors in computing discharge capacity, and minimum loss factors in computing velocities for the design of energy dissipators. As more model and prototype data become available, the range between maximum and minimum coefficients used in design may be narrowed. An illustrative example, in which the hydraulic design procedures and guidance discussed in this manual are applied to the computation of a discharge rating for a typical reservoir outlet works, is shown in Appendix D.

2-2. Basic Considerations. The hydraulic analysis of the flow through a flood control conduit or sluice usually involves consideration of two conditions of flow. When the upper pool is at low stages, for example during diversion, open-channel flow may occur in the conduit. As the reservoir level is raised, the depth of flow in the conduit increases until the conduit flows full. In the design of outlet works, the number and size of the conduits and the elevations of their grade line are determined with consideration of overall costs. The conduits are usually designed to provide the required discharge capacity at a specified reservoir operating level, although adequate capacity during diversion may govern in some cases. Conduits should normally slope downstream to ensure drainage. The elevation of good foundation materials may govern the invert elevation of conduits for an embankment dam. If it is planned to use the conduits for diversion, a study of the discharge to be

diverted at the time of closure of the river channel may limit the maximum elevation of the conduit. If the conduits are adjacent to the power penstocks, the level of which is governed by the turbine setting, it may be feasible and convenient to place all conduits on the same level. After limiting conditions are determined and preliminary dimensions and grades established by approximate computations, a more exact analysis may be made of the flow through the conduits. It is often more expedient to estimate the size, number, and elevation of the conduits and then check the estimated dimensions by an exact analysis rather than to compute the dimensions directly.

Section II. Conduits Flowing Partially Full

2-3. General. Analysis of partially full conduit flow is governed by the same principles that apply to flow in open channels. The longitudinal profile of the free-water surface is determined by discharge, geometry, boundary roughness, and slope of the channel. Reference is made to plate C-1 for illustration of the principal types of open-channel water-surface profiles. A study of the various profiles will indicate, for any particular conduit, where the discharge control is likely to be located and the type of water-surface profile that will be associated with the control.

2-4. Discharge Controls for Partially Full Flow.

a. Inlet Control. The control section is located near the conduit entrance and the discharge is dependent only on the inlet geometry and headwater depth. Inlet control will exist as long as water can flow through the conduit at a greater rate than water can enter the conduit. The conduit capacity is not affected by hydraulic parameters beyond the entrance, such as slope, length, or boundary roughness. Conduits operating under inlet control will always flow partially full for some distance downstream from the inlet.

b. Outlet Control. The control section is located at or near the conduit outlet; consequently, the discharge is dependent on all the hydraulic parameters upstream from the outlet, such as shape, size, slope, length, surface resistance, headwater depth, and inlet geometry. Tailwater elevation exceeding critical depth elevation at the outlet exit may influence the discharge. Conduits operating under outlet control can flow either full or partially full.

c. Critical Depth Control. Critical flow applies only to free surface flow and occurs when the total energy head (sum of velocity head and flow depth) for a given discharge is at a minimum. Conversely, the

discharge through a conduit with a given total energy head will be maximum at critical flow. The depth of flow at this condition is defined as critical depth and the slope required to produce the flow is defined as critical slope. Capacity of a conduit with an unsubmerged outlet will be established at the point where critical flow occurs. A conduit operating with critical depth occurring near the entrance (inlet control) will have maximum possible free-surface discharge. The energy head at the inlet control section is approximately equal to the head at the inlet minus entrance losses. When critical flow occurs downstream from the conduit entrance, friction and other losses must be added to the critical energy head to establish the headwater-discharge relation. Critical depth for circular and rectangular cross sections can be computed with CORPS^o H6141 or H6140 or from charts given in HDC 224-9ⁿ and 610-8,ⁿ respectively. Reference is made to TM 5-820-4^b and to King's Handbook (item 56) for similar charts for other shapes.

d. Gate Control. It is generally necessary to compute surface profiles downstream from the gate for different combinations of gate openings and reservoir heads to determine the minimum gate openings at which the conduit tends to flow full. The transition from partly full to full flow in the conduit may create an instability that results in slug flow pulsations ("burping") at the outlet exit portal which can create damaging wave action in the downstream channel (item 2). Generally, this instability occurs near fully open gate openings and the outlet works are not operated in this discharge range for any extended period of time. However, it is particularly critical in projects that have a long length of conduit below the gate, and the conduit friction causes the instability to occur at smaller gate openings that are in the planned operating range of the outlet works. The conduit must be examined for slug flow where the ratio of downstream conduit length to conduit diameter or height exceeds 75 (i.e., $L/D \geq 75$). A larger conduit or steepened invert slope may be required to avoid this condition. Additional details and an example analysis are given in Appendix D.

2-5. Flow Profiles. EM 1110-2-1601^h presents the theory involved in computing flow profiles for prismatic channels. Its application to the problem with a sample computation is given in Appendix D.

Section III. Conduits Flowing Full

2-6. General. The objective of the analysis of conduits flowing full is to establish the relation between discharge and total head and to determine pressures in critical locations. The solution is implicit and involves the simultaneous solution of the Darcy-Weisbach equation, the continuity equation, and the Moody diagram to determine the unknown

quantities. A detailed explanation of the computational procedure is presented in Appendix D. The total head H , which is defined as the difference in elevation of the upstream pool and the elevation of the hydraulic (pressure) grade line at the exit portal, is consumed in overcoming frictional (h_f) and form (h_l) losses and in producing the exit portal discharge velocity head (h_v). These component heads may be equated to the total head as follows:

$$H = h_f + h_l + h_v \quad (2-1)$$

Plate C-2 is a definition sketch showing the relation between these various components in an outlet works system.

2-7. Exit Portal Pressure Grade-Line Location. The elevation of the hydraulic (pressure) grade line at the exit portal for unsubmerged flow (into the atmosphere) is not as obvious as it may appear. Laboratory tests made at the State University of Iowa (item 103) have indicated that the elevation of the intersection of the pressure grade line with the plane of the exit portal is a function of the Froude number of the conduit flow. Plate C-3 shows the results of these and other tests for circular and other conduit shapes. The values of y_p/D are also dependent upon the condition of support of the issuing jet. The "Suggested Design Curve" on this plate is based upon analyses of model and prototype data. Plate C-3 indicates that a good approximation for the initial location is two-thirds the vertical dimension above the exit portal invert. Model and prototype tests have indicated the hydraulic (pressure) grade line at the exit portal can be depressed to near the conduit invert for certain geometrics and flow conditions (see Chapter 5, para 5-2d(2)). If the exit portal is deeply submerged, the hydraulic grade line at the outlet will be at the local tailwater elevation. However, at lower degrees of submergence the outflow will tend to depress the local water surface below the surrounding tailwater elevation. This depression and the accompanying hydraulic jump action for two-dimensional flow can be analyzed as described by Rouse or Chow (items 101 or 17, respectively). However, submerged conduit outflow into a wider channel is not subject to simple analysis. If submerged flow conditions are critical relative to conduit capacity, local pressures at the outlet, or stilling basin performance, a hydraulic model investigation will be needed.

Section IV. Gradients

2-8. General. The basic principle used to analyze steady incompressible

flow in a conduit is the law of conservation of energy as expressed by the Bernoulli equation. Generalized so that it applies to the entire flow cross section, the expression for the energy at any point in the cross section in foot-pounds per pound of water is given by:

$$H = Z + \frac{p}{\gamma} + \alpha \frac{V^2}{2g} \quad (2-2)$$

where

H = total head in feet of water above the datum plane

Z = difference in elevation of the point and the elevation of a datum plane

p = pressure at the point, lb/ft²

γ = specific weight of water, lb/ft³

V = flow velocity, fps

g = acceleration due to gravity, ft/sec²

α = dimensionless kinetic-energy correction factor

For many practical problems α may be taken as unity without series error.

2-9. Hydraulic Grade Line and Energy Grade Line. The hydraulic grade line, also referred to as the mean pressure gradient, is p/γ above the center line of the conduit, and if Z is the elevation of the center of the conduit, then $Z + p/\gamma$ is the elevation of a point on the hydraulic grade line. The locus of values of $Z + p/\gamma$ along the conduit defines the hydraulic grade line or mean pressure gradient. The location of the hydraulic grade line at any station along the conduit is lower than the energy grade line by the mean velocity head at that station as reflected by equation 2-2. See plate C-2 for a definition sketch of the energy grade line, hydraulic grade line, etc. The hydraulic grade line is useful in determining internal conduit pressures and in determining cavitation potentialities. Information on local pressure conditions at intakes, gate slots, and bends is given in the appropriate paragraphs of this manual. For purposes of structural design, pressure gradient determinations are usually required for several limiting conditions.

15 Oct 80

2-10. Mean Pressure Computation. The mean pressure at any station along a conduit is determined using the conservation of energy principle as expressed by the Bernoulli equation. The principle states that the energy at one station of the conduit (point 1) is equal to the energy at any downstream location (point A) plus any intervening losses. Expressed in equation form and in the units of equation 2-2,

$$Z_1 + \frac{p_1}{\gamma} + \alpha_1 \frac{V_1^2}{2g} = Z_A + \frac{p_A}{\gamma} + \alpha_A \frac{V_A^2}{2g} + H_{L_{1-A}} \quad (2-3)$$

If the upstream station is taken in the reservoir near the conduit entrance where the velocity head is negligible, and $Z_1 + (p_1/\gamma)$ is taken as the pool elevation, equation 2-3 reduces to

$$\frac{p_A}{\gamma} = \text{pool elevation} - \frac{V_A^2}{2g} - H_{L_{1-A}} - Z_A \quad (2-4)$$

Equation 2-4 is applicable to the general case of determining the mean pressure of any station along the conduit, with proper consideration being given to head losses due to friction and form changes between the entrance and station in question. For a uniform section, the pressure at any station (point A) upstream of the exit portal (point 2) can be determined by the following equation:

$$\frac{p_A}{\gamma} = Z_2 + y_p - Z_A + H_{L_{2-A}} \quad (2-5)$$

where

p_A/γ = pressure head in feet of water at any station

$H_{L_{2-A}}$ = total hydraulic loss in feet between the exit portal and the station

$Z_2 + y_p - Z_A$ = difference in feet between the mean pressure grade-line elevation at the exit portal and the point elevation at the station in question.

Section V. Energy Losses

2-11. General. Energy losses within conduits fall into two general classifications: (a) surface resistance (friction) caused by shear between the confining boundaries and the fluid and (b) form resistance resulting from boundary alignment changes. Computational procedures for both types are given in the following paragraphs.

2-12. Surface Resistance (Friction).

a. General. Three basic equations have generally been used in the United States for computing energy losses in pressurized systems. The Manning equation has been used extensively for both free surface and pressure flow. The Hazen-Williams formula has been used for flow of water at constant temperature in cast iron pipes. The Darcy-Weisbach formula is adopted in this manual and is preferred because through use of the Moody diagram (plate C-4), the Reynolds number and the effective roughness properly account for the differing friction losses in both the transitional and fully turbulent flow zones.

b. Darcy-Weisbach Formula. The Darcy-Weisbach formula is expressed as

$$h_f = f \frac{L}{D} \frac{V^2}{2g} \quad (2-6)$$

where h_f is the head loss, or drop in hydraulic grade line, in the conduit length L , having an inside diameter D , and an average flow velocity V . The head loss (h_f) has the dimension length and is expressed in terms of foot-pounds per pound of water, or feet of water. The resistance coefficient f is a dimensionless parameter. Moody (item 73) has constructed one of the most convenient charts for determining resistance coefficients in commercial pipes and it is the basis for pipe-flow computations in this manual.

c. Effects of Viscosity. Nikuradse (item 82) demonstrated by experiments that the resistance coefficient f varies with Reynolds number Re . (Reynolds number is defined in plate C-4.) Von Karman and Prandtl (items 142 and 94, respectively) developed a smooth pipe equation based on the Nikuradse tests as follows:

$$\frac{1}{\sqrt{f}} = 2 \log_{10} Re \sqrt{f} - 0.8 \quad (2-7)$$

This equation is shown as the "smooth pipe" on curve in plate C-4. Prototype tests have shown that a hydraulically smooth condition can exist in both concrete and steel conduits over a wide range of Reynolds numbers. Reference is made to plate C-4 for data from tests of concrete conduits and to HDC 224-1/1ⁿ for steel conduits.

d. Effect of Relative Roughness. The rough pipe tests of Nikuradse have served as a valuable basis for determining the effect of relative roughness (D/k). The symbol k represents the absolute roughness of the pipe wall, which for random roughness is taken as 2σ where σ is considered to be the root-mean-square of the height of the roughness elements. D represents the pipe diameter. The Von Karman-Prandtl (item 142) equation for a rough pipe and fully established turbulent flow is:

$$\frac{1}{\sqrt{f}} = 2 \log_{10} \frac{D}{2k} + 1.74 \quad (2-8)$$

Thus, for this type of flow, the resistance coefficient is a function only of relative roughness and is independent of Reynolds number. Therefore, representation of the equation appears as a series of horizontal lines on the upper right-hand portion of plate C-4. Values of f based on prototype concrete conduit measurements are plotted in this plate. These values of k were obtained mathematically from hydraulic measurements and are essentially effective roughness values rather than physical values. Very few published roughness coefficients (items 16 and 30) are physical values and all should be considered as effective or hydraulic rather than absolute roughness values. Rouse (item 101) has proposed an equation that defines the lower limit of the rough flow zone as follows:

$$\frac{1}{\sqrt{f}} = \frac{IR}{200} \frac{k}{D} \quad (2-9)$$

The equation is shown as a dotted line in plate C-4.

e. Transition Region. The area on the Moody diagram between the smooth pipe curve and the rough flow limit may be considered as a transition region. Colebrook and White (item 18) published an equation based on their experiments to span the transition region. The equation is:

15 Oct 80

$$\frac{1}{\sqrt{f}} = -2 \log_{10} \left(\frac{k}{3.7D} + \frac{2.51}{R \sqrt{f}} \right) \quad (2-10)$$

The relation is shown as dashed lines in plate C-4.

f. Noncircular Cross Sections. The Darcy f is expressed in terms of the conduit diameter and therefore is theoretically only applicable to conduits having circular cross sections. The concept of equivalent or hydraulic diameter has been devised to make it applicable to noncircular sections. This concept assumes that the resistance losses in a noncircular conduit are the same as those in a circular conduit having an equivalent hydraulic radius and boundary roughness.

$$D = 4R = \frac{4A}{P} \quad (2-11)$$

where

R = hydraulic radius of the noncircular conduit

D = diameter of a circular conduit having the same hydraulic radius

A = conduit area

P = wetted perimeter

A WES study (item 19) has shown that the equivalent diameter concept is applicable to all conduit shapes normally used in the Corps' outlet works structures. Plate C-5 gives the relation between A, P, and R for various common conduit shapes. Geometric elements of rectangular, circular, oblong, and vertical-side horseshoe-shaped conduits showing full or partly full can be computed with CORPS^o H2041, H6002, H2042, and H2040, respectively. See paragraph 4-2c for a discussion of when conduit shapes other than a circular section should be considered. Flow characteristic curves computed by the USBR (item 50) for their standard, curved-side, horseshoe-shaped conduit are presented in plate C-6. This shape is the same as that presented at the bottom of plate C-5.

g. Design Guidance for Roughness. The Colebrook-White equation (eq 2-10) is recommended for computing the resistance coefficient f since it is applicable to either smooth, transition, or rough flow

conditions. Computations of discharge and head loss at given total heads for rectangular, circular, or oblong, and vertical-side horseshoe-shaped conduits flowing full can be computed with CORPS^o H2044, H2045, and H2043, respectively. The solution is implicit; and without the aid of a computer, it is more convenient to graphically obtain values of f from a Moody-type diagram as illustrated in plate C-4. However, to use the Moody diagram requires knowledge of the effective roughness parameter. Recommended k -values for various conduit materials are shown below:

(1) Concrete. The following values of k are recommended for use in the design of concrete sluices, tunnels, and conduits.

(a) Capacity. Conservatively higher values of roughness should be used in designing for conduit capacity. The k values listed below are based on the data presented in paragraph (c) below and are recommended for capacity design computations.

Type	Conduit Size ft	k ft
Asbestos cement pipe	Under 2.0	0.0003
Concrete pipe, precast	Under 5.0	0.0010
Concrete conduits (circular)		0.0020
Concrete conduits (rectangular)		0.0030

(b) Velocity. The smooth pipe curve in plate C-4 should be used for computing conduit flow velocity for the design of outlet works energy dissipators. It should also be used for all estimates for critically low pressures in transitions, bends, etc., as well as for the effects of boundary offsets projecting into or away from the flow.

(c) Miscellaneous. Available test data on concrete pipes and conduits have been analyzed to correlate the effective roughness k with construction practices in forming concrete conduits and in treatment of interior surfaces (HDC 224-1ⁿ). The following tabulation gives information pertinent to the data plotted in plate C-4. The type of construction and the resulting effective roughness can be used as guides in specific design problems. However, the k values listed are not necessarily applicable to other conduits of different sizes.

15 Oct 80

Plate C-4 Symbol	Project	Shape*	Size ft	k ft	Construction
<u>Precast Pipe</u>					
●	Asbestos cement	C	1.2	0.00016	Steel mandrel
□	Asbestos cement	C	1.7	0.00008	Steel mandrel
▽	Neyrpic	C	2.82	0.00030	19.7-ft steel form
⊖	Denver #10	C	4.5	0.00018	12-ft steel form
⊓	Umatilla River	C	3.83	0.00031	8-ft steel form
T	Prosser	C	2.54	0.00152	Oiled steel form
⊔	Umatilla Dam	C	2.5	0.00024	4-ft sheet steel on on wood forms
⊥	Deer Flat	C	3.0	0.00043	6-ft steel form
×	Victoria	C	3.5	0.00056	4-ft oiled steel forms
▲	Denver #3	C	2.5	0.00011	12-ft steel form
▲	Denver #13	C	5.0	0.00016	12-ft steel form
▽	Spavinaw	C	5.0	0.00013	12-ft steel form
<u>Steel Form Conduits</u>					
○	Denison	C	20	0.00012	
△	Ontario	O	18	0.00001	Hand-rubbed
▼	Chelan	C	14	0.00061	
■	Adam Beck	C	45	0.00018	Invert screeded and troweled
⊕	Fort Peck	C	24.7	0.00014	
◇	Melvern	H	11.5	0.00089	
◆	Beltzville	C	7	0.00009	
<u>Wood Form Conduits</u>					
●	Oahe	C	18.3	0.00004	Joints ground
+	Enid	C	11	0.00160	

(Continued)

* C = circular, O = oblong, R = rectangular, and H = horseshoe.

Plate C-4

<u>Symbol</u>	<u>Project</u>	<u>Shape*</u>	<u>Size</u> <u>ft</u>	<u>k</u> <u>ft</u>	<u>Construction</u>
---------------	----------------	---------------	--------------------------	-----------------------	---------------------

Wood Form Conduits (Continued)

●	Pine Flat 52	R	5 × 9	0.00103	
●	Pine Flat 56	R	5 × 9	0 00397	Longitudinal planking

Miscellaneous

○	Quabbin	H	11 × 13	0.00015	Unknown
---	---------	---	---------	---------	---------

* C = circular, O = oblong, R = rectangular, and H = horseshoe.

(2) Steel.

(a) Capacity. The k values listed in the tabulation below are recommended for use in sizing cast iron and steel pipes and conduits to assure discharge capacity. The values for large steel conduits with treated interior surfaces should also be useful in the design of surge tanks under load acceptance. The recommended values result from analysis of 500 resistance computations based on the data presented in HDC 224-1/1ⁿ and in Table H of item 13. The data are limited to continuous interior iron and steel pipe. The recommended design values are approximately twice the average experimental values for the interior treatment indicated. The large increase in k values for large size tar- and asphalt-treated conduits results from heavy, brushed-on coatings.

<u>Diameter</u> <u>ft</u>	<u>Treatment</u>	<u>k</u> <u>ft</u>
Under 1.0	Tar-dipped	0.0001
1 to 5	Tar-coated	0.0003
Over 5	Tar-brushed	0.0020
Under 6	Asphalt	0.0010
Over 6	Asphalt-brushed	0.0100
All	Vinyl or enamel paint	0.0001
All	Galvanized, zinc-coated or uncoated	0.0006

15 Oct 80

(b) Velocity. The smooth pipe curve in plate C-4 is recommended for all design problems concerned with momentum and dynamic forces (stilling basins, trashracks, water hammer, surge tanks for load rejection, critical low pressures at bends, branches, offsets, etc.).

(c) Miscellaneous. The following tabulation summarizes the data plotted in HDC 224-1/1ⁿ and can be used as a guide in selecting k values for specific design problems. However, the k values listed do not necessarily apply to conduits having different diameters.

Project	Diameter ft	k ft	Remarks
Neyrpic	2.60	0.000010	Spun bitumastic coating
Neyrpic	2.61	0.000135	Uncoated
Milan	0.33	0.000039	Zinc-coated
Milan	0.49	0.000026	Zinc-coated
Milan	0.82	0.000071	Zinc-coated
San Gabriel	10.25	0.000004	Enameled
San Gabriel	4.25	0.000152	Enameled
Hoover	0.83	0.000133	Galvanized pipe
Fort Randall	22.00	0.000936	Tar-coated
Fort Randall	22.00	0.000382	Tar-coated
Fort Randall	22.00	0.000008	Vinyl-painted
Garrison	24.00	0.000005	Vinyl-painted

(d) Aging Effects. Interior treatment of pipes and conduits is of importance to their service life. Chemical, organic, and inorganic deposits in steel pipes and conduits can greatly affect resistance losses and conduit capacity over a period of time. Data by Moore (item 74) indicate that over a 30-yr period, incrustation of bacteria up to 1 in. thick formed in uncoated 8-in. water pipe. Similar conditions prevailed in 10-in. pipe where the bond between the pipe and the interior coal tar enamel was poor (item 38). Computed effective k values for these pipes were 0.03 and 0.02 ft, respectively. Data compiled by Franke (item 38) indicate that organic and inorganic incrustations and deposits in steel conduits up to 6 ft in diameter increased resistance losses by as much as 100 to 300 percent with effective k values increasing twenty to one-hundred fold. The data indicate that the interiors of some of the conduits were originally treated with a coat of bitumen. The changes occurred in periods of 5 to 17 yr.

(3) Corrugated Metal. The mechanics of flow in corrugated metal

15 Oct 80

and structural plate pipe are appreciably different from those occurring in steel and concrete pipe (items 44 and 117). Both the height of the corrugations (k) and their angle to the flow are important factors controlling the resistance coefficients (f) values. HDC 224-1/2 and 224-1/3ⁿ show the effects of pipe diameter, corrugation height and spacing, and flow Reynolds number for pipes with corrugations 90 deg to the flow. More recently Silberman and Dahlin (item 112) have analyzed available data in terms of pipe diameter, helix angle, and resistance coefficient and published a design chart based on these parameters. This chart is included as Plate C-7. The correlation shown indicates that pipe size and helix angle are of primary importance in resistance losses. The use of plate C-7 for the hydraulic design of corrugated pipe systems is recommended. Corrugated metal is not recommended for high pressure-high velocity systems (heads >30 ft, and velocities >10 fps). For this reason the published f values can be used for both capacity and dynamic design. Invert paving reduces resistance coefficients for corrugated metal pipe about 25 percent for 25 percent paved and about 45 percent for 50 percent paved.

(4) Unlined Rock Tunnels.

(a) General. Unlined rock tunnels have been used for flood flow diversion and hydropower tunnels where the rock is of sound quality. Generally, it is more economical to leave these tunnels unlined unless high-velocity flows are involved, considerable rock remedial treatment is required, or lining in fractured rock may be required. Existing resistance coefficient data have been studied by Huval (item 52) and summarized in HDC 224-1/5 and 224-1/6.ⁿ Field measurements of friction losses in the Corps' Snettisham diversion tunnel have been reported by WES (item 75). Accurate k values cannot be determined prior to initial tunnel blasting. Consequently, a range of probable k values based upon blasting technique and local rock characteristics must be investigated to determine tunnel size. Information of this type can sometimes be obtained by studying blasting techniques used and results obtained in the construction of tunnels in rock having similar characteristics. Adjustment to the tunnel size could be made after tunneling begins.

(b) Shape. Unlined rock tunnels are usually horseshoe-shaped. Structural stability normally requires a rounded roof. Economical blasting and rock removal operations usually require a flat or nearly flat invert.

(c) Limiting Velocities. Generally, velocities in unlined tunnels should not exceed 10 fps except during diversion flow when velocities up to about 15 fps may be acceptable. For a tunnel with downstream

turbines, penstocks, or valves, it has been recommended that velocities be limited to 5 fps or less to prevent damage from migration of tunnel muck fines and rock falls.

(d) Rock Traps. Rock traps must be provided where damage to downstream turbines, stilling basins, etc., can result from rock fall material moving with the flow. Access to these traps is required for inspection and occasional cleaning out. The development of satisfactory rock trap design and size is presented in items 23 and 66. A rock trap designed to trap debris without interrupting the tunnel flow is described in item 47.

2-13. Form Resistance.

a. General. Energy losses caused by entrances, bends, gates, valves, piers, etc., are conventionally called "minor losses" although in many situations they are more important than the losses due to conduit friction discussed in the preceding section (item 118). A convenient way of expressing the minor losses in flow is

$$h_l = K \frac{v^2}{2g} \quad (2-12)$$

where

h_l = head loss, ft

K = dimensionless coefficient usually determined experimentally

v = designated reference velocity, fps

g = acceleration due to gravity, ft/sec²

The reference velocity in the following energy loss equations corresponds to a local reference section of the conduit at or near the point where the loss occurs. In a conduit with varying cross-sectional area (and inversely varying average velocity) along its length, the individual local loss coefficients (K 's) can be adjusted to a single, general reference section for combining into a single total loss coefficient. To do this, each local coefficient (K) should be multiplied by a factor A_G^2/A_L^2 , where A_G is the cross-sectional area at the general reference section and A_L is the area at the local reference section.

b. Sudden Expansion. In almost all cases the loss coefficient

K is determined by experiment. However, one exception is the head loss for a sudden expansion (items 101 and 118). Designating the smaller upstream section as section one and the larger downstream conduit as section two, equation 2-12 may be written as

$$h_{\ell} = \left(1 - \frac{A_1}{A_2}\right)^2 \frac{V_1^2}{2g} = K \frac{V_1^2}{2g} \quad (2-13)$$

in which

$$K = \left(1 - \frac{A_1}{A_2}\right)^2 \quad (2-14)$$

where A_1 and A_2 are the respective upstream and downstream conduit cross-sectional areas, and the reference velocity is the upstream velocity V_1 . Note that the head loss varies as the square of the velocity. This is essentially true for all minor losses in turbulent flow. Furthermore, if the sudden expansion is from a submerged exit portal into a reservoir, $A_1/A_2 = 0$ and the loss coefficient K becomes unity and the head loss h_{ℓ} is equal to the velocity head. A plot showing K as a function of the area ratios is shown in plate C-8.

c. Sudden Contraction. Plate C-8 also illustrates the loss coefficient K as a function of a ratio of the downstream to upstream cross-sectional areas. The head loss h_{ℓ} due to a sudden contraction is subject to the same analysis as the sudden expansion, provided the amount of contraction of the jet is known (items 101 and 118). Using the downstream conduit velocity V_2 as the reference velocity, equation 2-14 may be written as

$$h_{\ell} = \left(\frac{1}{C_c} - 1\right)^2 \frac{V_2^2}{2g} = K \frac{V_2^2}{2g} \quad (2-15)$$

in which

$$K = \left(\frac{1}{C_c} - 1\right)^2 \quad (2-16)$$

15 Oct 80

where C_c is the contraction coefficient (i.e., the area of the jet at the vena contracta section divided by the conduit area at the vena contracta). Thus, as illustrated by plate C-8, the head loss at the entrance to a conduit from a reservoir is usually taken as $0.5 V^2/2g$, if the entrance is square-edged.

d. Transitions. Plate C-9 summarizes the available data for gradual expansions and gradual contractions in circular sections (conical transitions). Gradual expansions, which are referred to as conical diffusers (items 101 and 118) have been tested by Gibson (item 41), Huang (item 51), and Peters (item 92). These tests show the loss coefficient to be a function of the flare angle of the truncated cone. In the case of the gradual contraction, Schoder and Dawson (item 107) give the head loss in the upstream contracting section of a venturi meter as 0.03 to 0.06 ($V^2/2g$), where V is the throat velocity. More recent data by Levin (item 59) gives loss coefficient values for flare angles up to 90 deg. Levin's data appear on the bottom of plate C-9. The loss coefficients shown in plate C-9 are applicable in equation 2-13 for both expansions and contractions where the reference velocity is in the smaller conduit. Approximate loss coefficients for rectangular-to-rectangular and rectangular-to-circular transitions have been published by Miller (item 72).

e. Bends.

(1) General. The mechanics of flow in bends is discussed by Yarnell (item 146), Hoffman (item 49), Anderson (item 4), and Zanker and Brock (item 147). Anderson includes detail summaries of the literature with many design graphs. More up-to-date but less detailed summaries are presented by Zanker and Brock.

(2) Losses. The bend loss, excluding friction loss, for a conduit is a function of the bend radius, conduit size and shape, and deflection angle of the bend. It has been found that the smoothness of the boundary surface affects the bend loss, but the usual surface of a flood control conduit permits it to be classed as smooth pipe for the determination of bend losses. Hoffman (item 49) and Wasielewski (item 144) have established that bend losses are independent of the Reynolds number for values in excess of 200,000. The Reynolds number need not be considered for computing bend losses for the design of flood control conduits, but it may be of importance in small-scale models of bends. Dimensionless loss coefficients based on equation 2-12 have been determined experimentally for bends in circular (items 49, 144, and 146) and rectangular (items 64 and 116) conduits.

15 Oct 80

(a) Circular Conduits. Loss coefficients for circular conduits having circular or single miter bends with deflection angles up to 90 deg are given in plate C-10. Bend loss coefficients for multiple miter bends in circular conduits with deflection angles from 5 to 90 deg are given in plate C-11 (item 4).

(b) Rectangular Conduits. Loss coefficients for rectangular conduits having circular and single miter bends have been published by Sprenger (item 116) and Madison and Parker (item 64). Plate C-12 shows the effects of Reynolds number and bend radii on rectangular conduits having 90 deg bends and height-width ratios of 0.5 and 2.0. Plate C-13 gives relative loss coefficients for rectangular conduits having circular bends varying from 10 to 180 deg (item 64). The bend loss coefficient from plate C-12 should be multiplied by the appropriate relative loss coefficient given in plate C-13. Plate C-14 shows the effects of Reynolds number (IR) on loss coefficients for various triple bend combinations with IR in the vicinity of 10^5 (item 116).

f. Branches and Junctions.

(1) General. Branches (wyes, tees, etc.) are not normally found in outlet works but are encountered in the design of penstocks and water supply systems. Junctions (manholes) are frequently encountered in sewer (storm and domestic) design and junction boxes are occasionally used with gates as control structures for low-head outlet works. HDC 228-5th presents design information on pressure change coefficients for junction boxes with in-line circular conduits and illustrates a procedure to compute the head loss for these structures.

(2) Experimental Data. Early interest in dividing and combining flow was generally limited to commercial pipe fittings (Vogel (item 141, 1928); Petermann (item 91, 1929)). In 1938 the USBR (item 135) published the results of experiments on junction losses. This was probably the first effort to minimize head losses and optimize pressure conditions in large diameter branching conduits through experimental design. The more recent works of Marchetti and Nosedá (item 65), Syamala Rao (item 119), Ruus (item 105), and Williamson and Rhone (item 145) indicate the revival of interest in branches and junctions of large conduits. Miller (item 72) presents a summary of experimental data on dividing and combining flows in branches through 1970. Correlation of dimensionless loss coefficients from the literature is difficult because of the wide variations in geometry tested. Since structures of this type are not frequently used in reservoir outlet works, only the literature is cited to assist the designer.

g. Equivalent Length. Form losses may be expressed in terms of the equivalent length of pipe L_e that has the same head loss for the same discharge. Equating the head loss due to form losses and the Darcy-Weisbach equation,

$$f \frac{L_e}{D} \frac{V^2}{2g} = K \frac{V^2}{2g} \quad (2-17)$$

in which K may refer to one form loss or the sum of several losses. Solving for L_e

$$L_e = \frac{KD}{f} \quad (2-18)$$

For example, assume the total form loss coefficient in a 4-ft-diam conduit equals 20 (i.e., $K = 20$) and $f = 0.02$ for the main line; then to the actual length of conduit may be added $20 \times 4/0.02 = 4000$ ft, and this additional or equivalent length causes the same resistance as the form losses, within a moderate range of Reynolds numbers.

Section VI. Cavitation

2-14. General. (Items 8, 57, 97 and 127.) Cavitation is the successive formation and collapse of vapor pockets in low-pressure areas associated with high-velocity flow. Cavitation frequently causes severe damage to concrete or steel surfaces and it may occur at sluice entrances, downstream from gate slots, on edges of baffle blocks, at sharp bends in pipes, on tips of needle valves, etc. The roughening or formation of pockets in surfaces resulting from cavitation is commonly called "pitting." Surface erosion resulting from debris (rocks, gravel, etc.) is sometimes mistaken for cavitation, and cavitation damage may be difficult to determine from examination of the surface within the damaged area. Debris erosion may sometimes be identified by grooves in the direction of flow. While cavitation is normally associated with high-velocity systems, it can occur in low-velocity systems with certain local boundary geometry and flow conditions. The classical case is that of the venturi meter (item 99) in a low-head system (plate C-15). Cavitation is usually associated with closed systems such as in-line gates and valves, but it can occur locally in free-surface systems. Pressures in the cavitation range have been measured on a model of a navigation dam with a submergible tainter gate where the flow passages under the submerged gate had venturi-like characteristics. Similar flow conditions but with very high head losses can exist with lock culvert valves and

15 Oct 80

with conduit gates operating under submerged conditions (plate C-15). In effect, cavitation can occur following any constriction when the back pressure in the system allows the jet flow piezometric head to approach the vapor pressure of water.

2-15. Theory.

a. General. Cavitation results from the sudden reduction of local pressure at any point to the vapor pressure of water. Such reductions in pressure are caused in water passages by abrupt changes in the boundary which causes a tendency of separation of the flow from the boundary, by constrictions which produce high velocities and low pressures, and by siphons in which pressures are reduced by reason of elevation. Vapor cavities form as bubbles in the low-pressure areas and collapse when a higher pressure area is reached a short distance downstream. The collapse ("implosion") is very rapid and sets up high-pressure shock waves or possibly small, high-velocity local "jets" in the water that cause damage to the nearby boundary. The basic equation associated with cavitation studies is

$$\sigma = \frac{(p_o - p_v)}{\frac{\gamma}{\frac{V_o^2}{2g}}} \quad (2-19)$$

where

σ = general dimensionless cavitation parameter

p_o = absolute pressure, lb/ft²

V_o = average velocity of the flow

p_v = vapor pressure of the fluid at a particular temperature, lb/ft²

γ = unit weight of the fluid

Abrupt boundary changes also cause large local fluctuations in pressures and velocities. Computation of these fluctuations is essentially impossible and cavitation potential can only be investigated under carefully controlled tests. In such tests a value of σ_i is determined for incipient cavitation by visual or specially instrumented observations. The value of σ_i applies only for the particular geometry tested. As

15 Oct 80

long as σ 's for other flow conditions exceed σ_i , cavitation is not expected to occur. The reader is referred to the book by Knapp, Daily and Hammitt (item 57) for additional discussion on the theory of cavitation.

b. Effects of Temperature. The vapor pressure of water (p_v or p_v/γ) varies somewhat with the temperature of the water. The vapor pressure of fresh water at 40°F is about 0.29 ft of water and at 70°F is 0.83 ft of water. The variation in vapor pressure is not large compared with the variation in atmospheric pressure due to elevation above sea level. For example, atmospheric pressure at sea level is 34 ft of water, whereas at Denver, Colorado (elevation 5332), atmospheric pressure is 28 ft of water (see HDC 000-2^H). Thus, if the water temperature is 60°F, cavitation occurs at negative pressures of 33.4 and 27.4 ft of water at sea level and Denver, respectively.

2-16. Design Practice. Application of the theory of cavitation to practical design problems is difficult. Available design information on the magnitude of instantaneous pressure fluctuations is meager. In general, such fluctuations increase in magnitude with increasing total head. For this reason two minimum average pressure values are recommended for general design where the total head is less than 100 ft. These values are based on experience and should be conservative. Where boundary changes are gentle and streamlined, such as in entrances and transitions, minimum average local pressures as low as -20 ft of water can be expected to be cavitation-free. Where boundary changes are abrupt or the local flow is highly turbulent, such as at gate slots, offsets, and baffle piers of standard design, minimum average pressures should not be lower than -10 ft of water for safe design. In these highly turbulent cases, local instantaneous pressure fluctuations of +10 ft of water or more can be expected. For higher heads, an average pressure exceeding 0 ft of water is often necessary as instantaneous pressure fluctuations can materially exceed atmospheric pressure.

2-17. Preventive Measures. Once pitting has started in an outlet conduit, the effect of cavitation may be accelerated by the existence of a depression or hole in the surface which intensifies the local turbulence and the negative pressures in the area just downstream from the depression. Thus, early repair of pitted surfaces is important and should be done preferably with a more resistant material. Stainless steel welding has been used to repair cavitation damage to steel surfaces such as gate frames and turbine blades. Successful repairs have been made to concrete surfaces with epoxy concrete or mortar. The cause of cavitation should be determined and corrected or avoided if due to a particular operating condition. The preventive measures to be taken in

the design of outlet works conduits depend on particular conditions as follows:

a. Improvement of the shape of water passages to minimize the possibility of cavitation. Examples are the streamlining of conduit entrances, increasing the amount of offset and decreasing the rate of taper downstream of gate slots, and using larger bend radii.

b. Increasing the pressure by raising the hydraulic grade line at disturbance areas, which may be accomplished by flattening any downward curve, restricting the exit end of the conduit, or increasing the cross-sectional area in such localities as gate passages to decrease the velocity and increase the pressure.

c. Introducing air at low-pressure areas to partly alleviate negative pressure conditions and to provide air bubbles in the flow that will reduce the formation of cavitation pockets and cushion the effects of their collapse. In the design of high-head outlet conduits, it is often desirable to combine any two or all three of the above preventive measures. It is especially desirable to maintain a substantial back pressure in the vicinity of entrances, roof openings, bulkhead slots, and gate slots whenever the velocity is sufficiently high to produce cavitation. For long conduits, the pressure gradient will ordinarily produce the required back pressure, but for short conduits, gate passages frequently must be enlarged or exit constrictions provided to produce the back pressure. When conduits are to be operated at part-gate opening, special care should be taken to provide streamlined shapes at the aforementioned locations and downstream therefrom because back pressure will not be provided when the conduits flow partly full. The floor and walls of a conduit just downstream from a high-head gate are particularly vulnerable when operated at small openings for an extended period of time (items 93 and 136). It is especially important that during construction, small protrusions resulting from incorrect monolith alignment, concrete spills, unground welded joints, etc., not be permitted.

2-18. Boundary Layer. (Items 101 and 106.) Conduit systems are generally designed on the assumption that the boundary layer generated in the flow by the shear between the fluid and the boundary is fully developed and exists the entire length of the uniform conduit section. Tests at WES (item 129) and other places show, in fact, that conduit lengths of about 40 diameters are required for the boundary layer to become fully developed. A recent study reported by Wang (item 143) showed that for rough pipes, the wall shear stress became fully developed in about 15 diameters and the velocity profile was almost fully developed in 50 diameters for a Reynolds number range of 1.2×10^6 to 3.7×10^6 . In

15 Oct 80

sluices and conduits of very small length-diameter ratios, the exit portal flow can contain a central core having a velocity head approximating the full reservoir head. Energy dissipators for very short conduits should be designed using the total reservoir head.

2-19. Air Demand. Under certain conditions of operation, the pressure in a conduit may fall considerably below atmospheric pressure. Sub-atmospheric pressures, approaching the vapor pressure of water, may be accompanied by large fluctuations that can cause dangerous vibration or destructive cavitation, particularly in the gate section, and are therefore undesirable from the operating standpoint as well as for structural reasons. Large reductions in these pressure fluctuations can be effected by providing air vents through which air will flow into the conduit where less than atmospheric pressure exists. The vents usually open through the conduit roof immediately downstream from the service gate. (See para 3-17 for details.) Air requirements are most critical in this area and reach a maximum value when the service gate is operated at about three-quarters open under the highest head. It is particularly important that the air vent opening extend across the full width of the conduit, that the high-velocity air actually spreads across the full width, and that the water flow does not impinge into the opening. An illustrative example showing the methods used for determining the size of air vent required and for computing the pressure drop in such an air vent is presented in HDC 050-2.ⁿ The air discharge which must be supplied by air vents is dependent upon the rate of air entrained by high-velocity flow and upon the rate of air discharged above the air-water mixture at the conduit exit. Both factors are variable and are influenced by the hydraulic and structural features of the conduit and the method of conduit operation. Plate C-16 indicates the types of flow that cause air demand and the relative amounts. When conduit discharge is not influenced by tailwater conditions and a hydraulic jump does not form in the conduit, the jet issuing from a small gate opening forms a fine spray or mist that fills the conduit and is dragged along the conduit by the underlying high-velocity flow, finally producing a blast of air and spray from the exit portal. At large gate openings, a partial hydraulic jump is formed in the conduit and the jet will entrain air as previously cited; but the air inflow from the vent at the top of the conduit will be entrained by the turbulence of the jump and drawn by the jump action into the conduit flow downstream. Both conditions of water flow in the conduit result in reduced pressures at the back of the service gate and at the vent exit, thus causing air inflow through the vent. Air demand, in most instances, is not subject to a rigid analysis. Quantitative estimates of air requirements for design purposes have been based principally on empirical application of appropriate experimental and prototype data. A paper by A. A. Kalinske and J. M. Robertson

3

(item 55) correlated experimental data obtained on the rate of air entrainment by the hydraulic jump as a function of Froude number. Data on the prototype has also been obtained. A summary of existing data is presented in plate C-17. Data presented by Sharma (item 111) indicate that the air demand for free flow and spray conditions may be about 3 and 6 times, respectively, that for the hydraulic jump condition.

2-20. Air Flow. Air vent flow encountered in the hydraulic design of outlet works is generally treated as an incompressible fluid and consequently conveyance systems are designed using conventional hydraulic theory and procedures. In extremely high-velocity systems (>200 fps) the air should be treated as a compressible fluid and the system designed accordingly. Scott (item 109) has prepared many flow charts for designing air conveyance systems.

CHAPTER 3

SLUICES FOR CONCRETE GRAVITY DAMS

Section I. Basic Considerations

3-1. Location. Sluices for concrete dams are generally located along the center line of spillway monoliths (plate C-18). When more than one sluice per monolith is required they are spaced appropriately in each monolith (plate C-19). A sluice should never be located close to or straddling a monolith joint. Since it is also general practice to place crest piers on the center line of spillway monoliths, the sluice air vent intakes can be placed in the crest pier, eliminating any danger of submergence during spillway flow. Air vents should not be cross-connected below the highest possible pressure grade line. In some cases it may be desirable to locate the sluices in the nonoverflow section of the dam. Such a location requires either (a) a separate energy dissipator or (b) a careful design for discharging into the spillway energy dissipator.

3-2. Size, Shape, and Number. The sluices for concrete gravity dams usually have a relatively small cross-sectional area. One of the principal reasons for making the sluices small in cross section is adverse structural effects of large openings in a concrete gravity section. In addition, the use of a large number of small sluices, each controlled by individual gates, provides a finer degree of regulation than could be obtained from a smaller number of sluices of larger cross-sectional area. The flood control sluices installed in Corps of Engineers' dams are predominantly rectangular in cross section. The size of sluices usually varies from 4 ft 0 in. by 6 ft 0 in. to 5 ft 8 in. by 10 ft 0 in., depending on discharge requirements. Larger sizes may be indicated in certain cases. All sluices should be large enough for inspection, maintenance, and repair purposes.

3-3. Elevation and Alignment.

a. General. The reservoir operational requirements normally play an important part in determining the elevation of the flood control sluices. The inlets of the sluices must be set low enough to drain the reservoir to the required limits of drawdown (ER 1110-2-50^d). In a dam for flood control only, the reservoir is normally dry and the sluice inlet elevations are set at, or slightly above, the streambed with due consideration of the sluice outlet elevation relative to stilling basin design. In a multipurpose dam with fixed reservoir storage allocations and in which high reservoir stages may be maintained for long periods of

time, it may be desirable to have both high- and low-level sluices (plate C-18). Low-level sluices are sometimes desirable for the passage of sediment through a reservoir and for aiding in water quality control if a special intake tower is not provided. If the sluice intake is permanently or frequently submerged, the servicing and inspection necessary for maintenance are more costly than for a high-level sluice. A high-level sluice usually requires that the outlet portal be sloped to direct the flow along the face of an ogee spillway section or into a stilling basin. The invert may slope on a straight line from the intake to the outlet portal, or curve downward at some point downstream from the intake. Setting the outlet portal at a lower elevation than the intake reduces the pressure at critical locations such as the intake, gate slots, and bends. An area reduction is usually provided in the vicinity of the outlet portal of sluices to assure positive pressures in these sluices when operated under full gate openings, or the sluice is enlarged downstream of the gate to ensure open-channel flow at full gate openings. Area reductions may be used to spread the emerging jet.

b. Bends. Flow around conduit bends results in acceleration of flow along the inside of the bend accompanied by a local pressure reduction and the potential for cavitation (particularly for short-radius bends). Cavitation is not likely to occur in bends where long-radius curves are used. Pressure drop coefficients to evaluate cavitation potential for 90-deg bends are given in plate C-20. The minimum pressure occurs at 22.5 deg and 45 deg from the beginning of curvature for circular and rectangular conduits, respectively. Since the computed minimum pressure is an average pressure, the guidance given in paragraph 2-16 should be adhered to.

Section II. Sluice Intakes

3-4. General. Sluice intakes are integral parts of concrete spillways, and are usually rectangular in shape and flared in four directions. The curved entrance is followed by the sluice passage, normally having a height-width ratio of about 1.5:1 to 2:1. In some cases considerable economy in stop log costs can be effected by projecting the intake curves upstream beyond the face of the dam. This permits a reduction in the required size of the stop log or bulkhead gate. Bulkhead slots must extend vertically above the maximum reservoir pool or be provided with slot covers. Open roof slots for closure bulkheads at Kinzua Dam permitted flow through the slot and resulted in extensive cavitation damage downstream (item 20). Plate C-21 shows typical designs for flush and protruding sluice intakes.

3-5. Trash Protection. The intake may be equipped with struts or

15 Oct 80

trashracks, depending upon the need for protection against clogging and debris damage to gates and turbines.

a. Trash Struts. A simple trash strut usually of reinforced concrete with clear horizontal and vertical openings not more than two-thirds the gate or other constricted section width and height, respectively, should be adequate for highly submerged flood control outlet conduits. The purpose of such struts is to catch trees and other large debris which may reach the entrance but would not pass through the gate passage, thereby possibly preventing closure of the gates. Trash struts should be located to effect local net-area velocities not greater than 15 fps. A flow net or model test should be used to determine local velocities through this area (items 99, 101, and 135). The struts should be circular cylinders or have rounded noses and square tails, depending upon the structural design requirements and economy. Teardrop designs are not required if the local velocity guidance is maintained. Trash strut losses are usually included in the overall intake loss. If necessary to consider separately, use of equation 2-12 is recommended with a loss coefficient K value of 0.02. V in this equation is the flow velocity in the uniform conduit section just inside the intake. Trash struts should be provided with a working platform located above conservation pool elevation to facilitate removal of debris. Additional information on the design of trash struts is given in EM 1110-2-2400.^J

b. Trashracks. Trashracks are provided where debris protection for downstream devices such as valves or turbines is required (item 22). Such racks are designed to retain debris of such size and type of material that could result in damage to these devices. Because of danger of overstressing from clogging, trashracks should be located in lower velocity areas than trash struts and must be provided with raking or cleaning facilities. They should be designed for safe operation with 50 percent clogging. Such devices can be fabricated from circular bars and pipe. Trashracks should not be located in velocities exceeding 3 to 4 fps. Where additional strength is required, elongated sections with rounded noses and tails can be used. Trashrack head losses depend on the flow velocity and area construction (items 22, 39, 100, 108, and 135). The design of vibration-free trashracks is necessary to prevent failure from material fatigue. It is especially important where reverse flow can occur (items 21, 37, 53, 63, and 110).

3-6. Entrance Curves.

a. General. The curved converging section, which begins at the upstream face of the dam or intake structure and terminates in tangency to parallel walls, is commonly referred to as the entrance section.

The curves that determine the rate of convergence are designated as entrance curves. It is the function of the entrance section to guide the flow with minimum disturbance until it is contracted to the dimensions of the gate passage or to the upstream transition of an ungated intake. If the entrance curve is too sharp or too short, negative pressure areas may develop in the entrance section where the jet is inadequately supported or improperly guided. On the other hand, a long and gradual entrance curve may require an unnecessary amount of expensive forming. The objective is to design an entrance of minimum length in which positive pressures can be maintained at all flows.

b. Circular Inlets. A bell-mouthed entrance, which conforms to or encroaches very slightly into the free jet profile of a circular orifice, eliminates occurrence of negative pressure in localized areas at the entrance to a circular conduit (see p 414 of item 101). An elliptical entrance curve for a circular conduit will satisfy the required streamlining and jet contact requirements if the curve is expressed by the following equation:

$$\frac{X^2}{(0.5D)^2} + \frac{Y^2}{(0.15D)^2} = 1 \quad (3-1)$$

where X and Y are coordinates measured parallel to and perpendicular to the conduit center line, respectively, and D is the diameter in feet.

c. Noncircular Inlets. The sluices of a concrete dam are commonly rectangular in cross section. WES (item 128) has tested entrance curves of various shapes. A laboratory-tested elliptical curve is shown in figure a, plate C-22, with the pressure drop coefficients. This simple ellipse is normally satisfactory. For designs of high-head dams and when the conduit has insufficient length to produce substantial back pressure, the compound elliptical curve (fig. b, plate C-22) should be used. HDC 211-1/2ⁿ shows the effect of upstream face slope of the dam on the entrance curve pressures.

3-7. Intake Energy Losses. Intake head losses are considered to include all the energy losses between the reservoir and the sluice proper. The head loss includes the form losses generated by the entrance curves, bulkhead or stop log slots, gate passage and gate slot, air vents, and the transition between the intake and the sluice proper. They also include the friction losses occurring in the intake structure. Intake losses are experimentally determined (model and prototype) by assuming

15 Oct 80

that the fully developed turbulent friction gradient exists between the conduit exit portal and the intake as shown in plate C-2. On the basis of limited model and prototype intake loss data for sluices, an intake loss coefficient value of 0.16 is recommended for capacity design and a value of 0.10 when high velocity is critical. When gate slot losses are not included in the intake loss, a value of 0.01 for each gate may be considered. If trashracks are provided this value should be increased in accordance with data referenced in paragraph 3-5b.

Section III. Gate Passage, Gates, and Valves

3-8. General. The gate passage may be defined as the passageway in which the gate leaves operate. The hydraulic design problems of the gate passage are often closely associated with the structural and mechanical problems in the design of the gate, gate frames, and gate hoist. One of the most important problems in design of gates and appurtenant features is to eliminate cavitation. A basic condition is whether the gate will be required to operate partially open or will only be operated fully open. When high-head gates are operated under partial opening, they may be subject to severe cavitation and vibration and have a high air demand. When valves are used for regulation they are commonly placed at or near the downstream end of the outlet conduits. This location permits the valves to discharge freely into the atmosphere and eliminates most of the cavitation potential. In some cases, however, the spray so produced may be troublesome to power plants and switchyards. Gate passages of circular cross section are designed when necessary to accommodate circular gates or valves, such as knife or ring-follower gates or butterfly, fixed cone, or needle valves. Rectangular gate passages are used for ordinary slide, tainter, and tractor or wheel-type gates.

3-9. Gate Types.

a. Vertical Lift. Vertical-lift gates for outlet works are defined according to their method of movement. Due to the friction between the gate and the vertical guides, slide gates are generally operated by hydraulic cylinders. Tractor and fixed-wheel gates are used where closure of large openings is required. Tractor gates move on an endless chain of rollers on each side of the gate. Fixed-wheel gates have a series of wheels down each side of the gate which bear on vertical guides in the gate slots. Vertical-lift gates are operated either by cables or a rigid stem connection to the hoist mechanism. Cable-suspended gates operate in open wet wells which fill to the reservoir pool elevation when the gate is closed; therefore, the hoist mechanism is located at an elevation above the maximum pool level. This type of

operation is not usually used for gates which operate partly open for long periods of time because of possible vibration. See paragraphs 4-18 and 4-19 for design problems concerning cable-suspended gates. Hydraulically operated gates are preferred for high heads and for long periods of operation at partial openings. These gates have rigid riser stems that recess into bonnets or extend to a higher floor level where the hydraulic hoist mechanism is located. The hydraulically operated slide gate is used preponderantly in designs for service gate installations in sluices of concrete dams. The rectangular slide gate generally has a height greater than the width to minimize both the flexure on the horizontal members and the unit loads on the vertical guides, and to reduce the possibility of binding in the slot. The cross-sectional shape of the gate passage in the sluice is usually the same as the shape of the gate. The upstream face of vertical-lift type gates must be flat rather than "bellied," as some gates were in the past, and the 45-deg lip should terminate in a 1-in. vertical extension (see plate C-23). Rating curve computations are discussed in paragraph 4-16 and in Appendix D.

b. Tainter Gates. Tainter gates have been used in the Pacific Northwest as service gates in sluices operating under extremely high heads (>250 ft). The characteristics of the tainter gate are favorable to its use for accurate reservoir regulation in both concrete and embankment dams. Advantages of the tainter gate over the vertical-lift type gate include: gate slots are not required in the walls of the gate passage, which is favorable in partly open gate operation; a relatively small hoist capacity is required because the direction of the resultant water load is through the trunnions; and the friction between the gate seals and the gate passage walls is low. A disadvantage of the tainter gate is that the entire gate cannot be easily lifted out of the well for maintenance. Tainter gates are placed in an enlarged section of the sluice and some have eccentric trunnions to facilitate movement and sealing under a very high head. The enlarged gate section may include an invert step-down as well as side and roof offsets to provide for complete sealing and for aeration of the jet which most frequently discharges as open-channel flow downstream at full gate opening. Under this condition, back pressure in the intake section is essentially nonexistent and the boundary layer is not fully developed. A model study is usually required to resolve pressure and vibration problems in pressure flow conduit designs. Discharge coefficients of a partially opened tainter gate in a rectangular conduit are shown in plate C-24. In general, the discharge coefficient can be considered the same as the contraction coefficient based on a study of the jet profile (HDC 320-3ⁿ).

3-10. Control Valves.

a. Valve Hydraulics. Knife gate, needle-type, fixed-cone, and various commercial valves have been used for flow control. Discharge rating curves for a valve discharging freely into air or into an enlarged, well-vented conduit can be developed from the equation

$$Q = CA\sqrt{2gH} \quad (3-2)$$

where

Q = discharge in cfs

C = discharge coefficient

A = nominal conduit or valve flow area in ft²

H = energy head immediately upstream and generally measured from the center line of the conduit in feet of water

g = acceleration due to gravity in ft/sec²

Discharge coefficients for freely discharging valves of many types have been determined empirically and will be presented in subsequent discussions on specific valve types. Head loss across in-line valves in pressure conduits can be computed by equation 2-12 using the dimensionless valve-loss coefficient K determined experimentally for the particular valve and valve opening.

b. Butterfly Valves. Butterfly valves have been used extensively for cutoff valves but are not recommended for flow regulation. There is evidence that the butterfly valves in the 11-ft-diam flood control conduits at Summersville Dam may have contributed to the failure of the 9-ft-diam fixed-cone valves immediately downstream (item 80).

c. Needle-Type Valves. The needle valve opens and closes by the horizontal movement of a needle; the valve is closed when the needle is advanced to its extreme downstream position. The water flows in an annular passageway first diverging and then converging past the needle. Discharge from needle valves can be computed using equation 3-2, where A and H are the area and energy head, respectively, at the inlet end, and C is a discharge coefficient. Kohler and Ball (in Davis and Sorensen, item 24) show the full open coefficient to be about 0.60 when

the ratio of outlet diameter to inlet diameter is 0.95. Thomas (item 120) gives discharge coefficients for partly open 86-in. needle valves. The hollow-jet valve is a modification of the needle and the needle moves upstream to close the outer casing of the valve. Model tests of the hollow-jet valve for Anderson Ranch Dam showed fully open discharge coefficients of approximately 0.70. Thomas also presents discharge coefficients for partly open valves in item 120. Nag presents a good summary of the characteristics, the uses, and the limitations of free discharge regulating valves in item 78.

d. Fixed-Cone Valves. The fixed-cone valve is similar in principle to the hollow-jet valve except that the cone pointing upstream on the downstream end is stationary and a sleeve of the outer casing moves downstream to close the valve. The shape of the issuing jet is a hollow cone. The discharge coefficient curves for fixed-cone valves are shown in plate C-25. The coefficients for the six-vane valve are based on tests by TVA (item 29). A comparable coefficient curve for a four-vane valve reproduced from HDC 332-1ⁿ is also shown in this plate. Model-prototype confirmation of the hydraulic characteristics of these valves has been studied by Lancaster (item 58). The shell of a six-vane valve has been found to be less likely to vibrate than that of a four-vane valve. In a number of cases, flow-induced vibration of fixed-cone valves has resulted in serious and costly damage (items 71 and 80). Hoods can be designed for these valves to control the spray of the jet (items 31 and 81).

e. Commercial Valves. Many types of commercially available valves are available for small conduits and water-supply systems. Some of those most commonly used are the knife gate and other gate valves. Head loss coefficients for lenticular- and crescent-shaped opening, in-line gate valves are given in HDC 330-1.ⁿ Knife gate valves are recommended for free discharge installations.

3-11. Metering Devices. Where accurate monitoring of outflow is required the inclusion of a metering device in the system should be considered. Many schemes can be considered, varying from venturi and elbow meters to acoustic and electronic systems. The installation of such devices eliminates the need for extensive calibration of gates and valves under varying operating conditions and generally results in flow measurements with errors from about +5 percent to +1 percent. It is necessary that all flow measuring devices of these types be installed according to standard specifications for proper, cavitation-free operation. If the provision of metering equipment is contemplated, WES should be consulted relative to available types and to their installation and operation requirements and limitations.

3-12. Gate Passageway Requirements. Normally, when reservoir outlet flows require regulation the following are provided:

a. Two or more gate passages such that if one passage is inoperative, a reasonable flow regulation as pertains to project purposes is obtained.

b. Emergency gate provision (tandem or transferable) for each service gate passage so that if a service gate is inoperative in any position, closure of the gate passage can be made with the emergency gate for any pool level.

c. Bulkhead provisions for each gate passage for inspection and maintenance of the service and emergency gates. As a minimum, the bulkheads must be capable of being installed at the lowest pool elevation that has a reasonable frequency and length of occurrence sufficient for inspection and repair purposes. All judgment factors involved in the above should be fully discussed in the design memorandum presentation.

3-13. Gate Slots. The guide slots of rectangular gates produce a discontinuity in sidewalls which may cause cavitation, unless specially designed. It has been common practice to use metal-liner plates downstream from the gate slots to protect the concrete from the erosive action of cavitation. The recommended guide lines for metal liners are given in paragraph 3-16. The gate slot in the roof of the gate chamber and air vent slots present similar design problems. Design details for slide gate roof, side, and air vent slot details are shown in plate C-23. Pressure coefficients (item 123) for detailed examination of this gate slot design for high heads (>250 ft) are given in figure a, plate C-26. To obtain dimensional local gate slot pressure data, the pressure coefficients given in this plate are multiplied by the flow velocity head in the gate passage and algebraically added to the back-pressure gradient elevation at the gate slot. Tests by Ball (item 6) show that doubling the downstream taper length from 12 to 24 units reduces the severest pressure drop coefficients (C) from -0.16 to -0.12 for comparable slot geometry. Therefore, it is recommended that for heads >250 ft the taper downstream of the gate slot be modified to 1:24. For conservative estimates of minimum pressures at gate slots where streamlining is not provided, the pressure coefficients in figure b, plate C-26, should be used. In detailed design studies it may be desirable to check the gate slot design for potential incipient cavitation. This can be done by solving equation 2-19 for the absolute conduit pressure p_o necessary for cavitation and comparing it with the computed minimum pressure at the slots. Plate C-27 gives incipient

15 Oct 80

cavitation coefficients σ_i for various slot geometries. These values were obtained using relatively large scale (1:3) plastic models to reduce possible errors from scale effects. A σ_i value of 0.4 is recommended to check cavitation potential. For conservative design, the computed minimum pressure should be appreciably higher (15 ft or more) than the incipient cavitation pressure. The head losses for gate slots are generally included in the composite intake loss discussed in paragraph 3-7. When gate slot losses are not included in the intake loss, a loss coefficient K value of 0.01 is recommended for each pair of gate slots for use in equation 2-12.

3-14. Gate Recess. Hydraulically operated control gates recess into bonnets and cable-suspended gates into wet wells. The necessary dimensional clearances for gate operation are usually based on mechanical and structural requirements rather than hydraulic. The primary hydraulic consideration is the relative upstream and downstream clearance at the roof recess when the gate passage is operated at part gate opening. The upstream clearance at the roof should be appreciably larger than the downstream clearance to assure maintenance of a hydrostatic head in the well or bonnet for gate stability. If the downstream clearance exceeds the upstream clearance the gate well can be sucked dry and the gate may float or catapult or oscillate under certain operating conditions (see para 4-18b).

3-15. Gate Seats. In general, the gate seat is flush with the floor of the gate passage.

3-16. Steel Liners. Steel liners in concrete conduits have been used where experience indicates cavitation is likely to occur such as downstream from control gates and valves where a high-velocity jet occurs. For heads above 150 ft, a metal liner should extend 5 ft downstream from the gate. For heads below 150 ft, no liner should be required. If a liner is necessary, it should not terminate at a monolith joint or in a transition.

3-17. Air Vents. The following guidance is recommended for air vent design:

a. Control valves and gates that are located a considerable distance upstream from the exit (i.e., do not discharge into the atmosphere) require air vents. An air vent is required for each service gate. Air vents are not required for emergency gates when those gates are located immediately upstream of air-vented service gates. Extreme caution must be observed if the emergency gate is used for regulation. Air demand will create very low pressures in the service gate recess. The

attendant conditions must be carefully analyzed to prevent damage and/or danger to personnel.

b. The size of air vents can be determined as per HDC 050-2ⁿ which assumes that the maximum air demand occurs at a gate opening of 80 percent fully open and the maximum air velocity in the vent does not exceed 150 fps. It is further suggested that air vents be designed so that the head loss through the vent not exceed 0.5 to 1.0 ft of water (i.e., air vent outlet pressure head of -0.5 to -1.0 ft of water). Although air vents are usually designed assuming incompressible flow, high-velocity local flow should be checked to determine if flow is incompressible (item 109).

c. Air vent passages should use generous bend radii and gradual transitions to avoid losses and, particularly, excessive noise.

d. Air vent intakes should be so located that they are inaccessible to the public and they should be protected by grills. The intake entrance average velocity should not exceed 30 fps.

e. Interconnected air vents (one main vertical stem manifolded to vent more than one gate) should be avoided; but if they are necessary, the connections should be above the maximum possible elevation of the pressure grade line at the air vent exit opening to prevent crossflow of water.

f. The air vent exit portal should be designed to assure spread of air across the full width of the conduit. The air vent should terminate into a plenum located in the conduit roof and immediately downstream of the gate. The plenum should extend across the full width of the conduit and should be vaned so that the air flow is evenly distributed. Plate C-23 illustrates a typical air vent exit into the gate chamber.

Section IV. Sluice Outlet Design

3-18. General Considerations. Generally, sluices should not be designed for combined spillway and sluice operation. However, in cases where large sluice capacity is required for diversion flows or normal reservoir regulation, combined operation may be considered and evaluated in terms of economic, hydrologic, and hydraulic benefits to be obtained. Potential benefits include (a) reduction in spillway length with savings in spillway and stilling basin construction costs, (b) reduction in maximum head on the spillway, and (c) more advantageous use of reservoir surcharge to reduce peak outflows. Simultaneous spillway and full sluice operation should be limited to conditions of thick (at least 10 ft)

spillway nappe flow over the outlet to minimize the possibility of negative pressures at the sluice exit portal (item 15). With thinner nappes, the sluice flow should be limited to 40 to 70 percent gate openings to obtain maximum air intake to relieve low pressures at the exit portal and on the spillway face immediately below (item 140). Experience with combined operation has been limited to structures not exceeding 150 ft high. Caution should be used in designing for greater heights where very high velocities and thinner spillway nappes would occur. In general, sluices should be closed when spillway operation begins. In projects not model-studied for combined flow operation, combined flow should only be permitted when the free flow capacity of the spillway is expected to be exceeded and the structure is endangered. The sluices should be opened and operated preferably only with a thick spillway nappe flowing over the sluice outlets. One sluice inoperative should not jeopardize the integrity of the dam. Operation and reservoir regulation manuals must reflect these restrictions.

3-19. Exit Portal Constructions. A sluice in a concrete dam is seldom long enough to develop the desired back pressure from friction losses necessary to prevent cavitation damage and it may be desirable to use an exit constriction. A 10 to 15 percent area constriction at the exit portal can be provided by gradually depressing the conduit roof from some point upstream to the exit portal or by a deflector formed in the exit portal invert (plates C-28 and C-29). Roof constrictions should be used when the sluice is curved vertically downward to terminate the conduit invert tangent to the sloping spillway face or to the spillway toe curve (plate C-28). This type of design does not aid in horizontal spreading of the sluice jet; but if jet spreading is required to improve stilling basin performance, it can be accomplished by flaring the sidewalls in combination with a roof constriction (plate C-30), or by use of sidewall flare with a tetrahedral deflector (plate C-29). Both designs require extension of the sidewall flares in the spillway face downstream of the exit portal. Tetrahedral deflectors are also used when the sluice forms an abrupt junction with the spillway face and the sluice flow spreads in a free fall into the tailwater (plate C-29). When the sluice is appreciably above the spillway toe curve and spreading of the sluice jet is not a problem, gradual depression of the sluice exit portal roof and curving the sluice vertically downward to a smooth junction with the sloping spillway face (plate C-30) is preferable to deflector blocks and the jet plunging into the stilling basin.

3-20. Sluice "Eyebrow" Deflectors. Extensive cavitation damage has occurred at exit portals during spillway flows with and without simultaneous sluice operation. This damage usually originates at low

pressure areas where the outlet portal roof intersects the spillway face and progresses downward along the intersection of the sluice sidewalls and the spillway face. USBR studies (item 140) of the Folsom Dam spillway showed that when the junction between the sluice invert and the spillway face is abrupt, the spillway jet can impinge upon the sluice invert with part of the flow entering and intermittently filling the sluice. This restricts effective venting by the sluice gate air vent with subsequent subatmospheric pressure at the sluice outlet roof. The USBR tests also showed that impinging of the spillway flow on the sluice exit portal invert resulted in flow separation from and undesirable low pressure on the spillway face downstream. The use of "eyebrow" deflectors on the spillway face (plate C-31) effectively lifted the spillway jet away from the sluice invert and permitted adequate venting of the exit portal by the sluice gate air vent. However, undesirable low pressures at full sluice gate opening were still evident immediately downstream on the spillway face. Deflectors of this type have been model-tested by the Corps of Engineers for Detroit, Red Rock, and other projects.

CHAPTER 4

OUTLET FACILITIES FOR EMBANKMENT DAMS

Section I. Basic Considerations

4-1. Approach Channel. The purpose of the approach channel is to convey the water from the reservoir to the conduit intake structure. In some cases, the channel may function for diversion of the river during construction. The outlet channel design, unless extremely long, is usually dictated by the outlet works size and alignment. The alignment of the approach channel should take advantage of the area topography to decrease the channel excavation. Excessive curvature in the outlet channel near multiple gate intake structures should be avoided to help prevent unequal distribution of flow through the gate passages.

4-2. Conduits and Tunnels for Embankment Dams.

a. Alignment. The alignment and grade of conduits and tunnels are governed by diversion, evacuation, and operating requirements; tailwater elevation; topography; foundation conditions; and location of the dam and spillway. It is desirable to design conduits or tunnels that are as straight in alignment as practical, since a bend increases the hydraulic losses and creates unbalanced flow downstream from the bend. If it is necessary to change the direction of flow, the change should be accomplished with a long, easy, circular curve. The curved section should be located as far upstream from the exit portal as feasible in order to improve the flow conditions in the stilling basin. A model study should be made for questionable cases. Flow around bends causes dynamic and static reactions against the conduit or tunnel wall which should be considered in design, particularly for free-standing steel conduits within tunnels. Conduits and tunnels should have adequate slope for drainage; and when appreciable foundation settlement caused by embankment loading is anticipated, the vertical alignment should contain sufficient camber to compensate for the settlement.

b. Conduit Elevation. As with sluices for concrete gravity dams (see para 3-3a), the reservoir appurtenance requirements play an important part in determining the elevation of the flood control conduit. The inlets must be set low enough to drain the reservoir as required (ER 1110-2-50^d) with due consideration of the conduit elevation relative to stilling basin design. A conduit at a low level may have better foundation conditions and higher discharge capacity for diversion and other low pool level operation; however, a longer conduit may be required and poor stilling basin action may result from high tailwater

levels. Higher level conduits may have shorter length and the best potential for good stilling basin action and good flow conditions through the conduit for all discharges; but foundation conditions may require its location to be farther from the river channel, and a larger conduit may be needed for diversion or design capacity.

c. Shape. Flood control conduits for embankment dams are usually either cut-and-cover or tunnel construction. Although some cross-sectional shapes are superior to others from a hydraulic standpoint, structural and construction considerations usually establish the type of cross section. A circular cross section is the most efficient section for a tunnel flowing full. Horseshoe-shaped and rectangular sections provide large flow areas at low depths, which make them desirable for diversion purposes. The discharge capacity decreases sharply when the depth of flow in a rectangular conduit increases from nearly full to completely full flow, since the wetted perimeter is suddenly increased. The oblong shape has depressed pressure gradients at the exit portal compared with other shapes, when the outlet chute walls act somewhat like a draft tube (see para 5-2d(2)). Hydraulic characteristics of several shapes are shown in plate C-5.

d. Spacing. Where more than one conduit or tunnel is required, the spacing affects the stilling basin and intake design. Multiple cut-and-cover conduits should be spaced as close together as structural requirements permit in order to allow use of a single stilling basin and a minimum width intake structure. EM 1110-2-2901^k discusses the spacing of multiple tunnels from the standpoint of geological and structural requirements. If the tunnels are designed with individual stilling basins, the spacing at the outlet portal must be sufficient to provide the necessary width of stilling basin for each outlet.

Section II. Intake and Gate Facilities

4-3. Intake Structures. The types of intake structures commonly used include gated tower, multilevel, uncontrolled two-way riser, and/or a combination of these. Intakes and control gates for embankment dams are discussed as integral structures, but if designed as separate structures, the principles of the hydraulic design are essentially the same. The hydraulic design of the intake structure should address the problems of (a) head loss, (b) boundary pressures, and (c) vortices in the approach.

a. Loss Coefficients. Loss coefficients for conduit intake structures with all gates operating range from 0.06 to 1.32 times the conduit velocity head. Available data from various geometries and gate

operating schedules are summarized in plates C-32, C-33, and C-34. It is recommended that for discharge calculations, conservative values be selected from these plates in accordance with the planned intake geometry. Many of the coefficients given include allowance for trash struts or fender losses.

b. Boundary Pressures. Pressure gradients for intake structures should be developed to show local average pressure changes resulting from flow velocity changes. These gradients are helpful in evaluating pressure conditions in intakes, gate passages, and transitions. They should be examined in terms of the conduit back pressure for the entire operating range. This can be done by applying the energy equation (eq 2-3) to local changes in areas. Average pressures do not reflect pressure fluctuations due to turbulence, and cavitation potential should be evaluated according to the criteria discussed in paragraph 2-16.

c. Vortices. Vortices at intake structures can affect intake efficiency and create a safety hazard to the public. Although vortices are usually associated with high discharges and shallow intakes, they have been observed at intakes submerged as much as 60 to 100 ft (items 43, 95, 125, 131, and 138). Antivortex devices have been installed at intakes located at shallow depths. The intensity of the circulation phenomena set up around an intake is a function of the submergence of the intake, the discharge, and the intake and approach channel geometry. Gordon (item 43) has developed design guidance for preventing undesirable vortices (intensity such that they draw air and surface debris into the structure) at power plant intakes (plate C-35). Data for observed prototype vortices at Enid (item 131) and Denison (item 125) Dams have been included in this plate. It is recommended that Gordon's curve for unsymmetrical flow be used for design purposes. Reddy and Pickford (item 95) have analyzed vortex data pertinent to pump sumps and published a design chart for evaluating vortex potentiality for these structures. They concluded that when vortex prevention devices are used the critical submergence (ratio of water depth above top of inlet to inlet diameter - both dimensions at the entrance to the inlet bell mouth) should equal or exceed the inlet flow Froude number (otherwise, it should equal or exceed Froude number plus one) to provide vortex-free operation. Model studies are suggested in questionable instances.

d. Trashracks and Struts. If protection against clogging or debris damage to gates or turbines is needed, see the design guidance given in paragraph 3-5.

4-4. Intake Tower Versus Central Control Shaft. Both the intake tower and the central control shaft have their respective advantages. The

intake tower may be expected to have higher back pressure at the gate section caused by the friction loss of the long downstream conduit. This is an advantage in the elimination of possible cavitation. As the intake tower has gates near the upstream end of the conduit or tunnel, the danger of leakage into or out of the embankment or abutment, with resultant piping of the material, is minimized. When the gates are placed near the upstream end of a conduit, there is the important advantage of being able to unwater the entire length of conduit for inspections. A central control shaft, which is usually located in an abutment near the axis of the dam, has the advantage of being protected from freezing and thawing and from forces due to ice action. In a central control the intermediate pier or piers are subject to high velocities and are designed to eliminate possible cavitation. The central control shaft has an advantage of not requiring a bridge for access as is the case of an intake tower. However, the conduit upstream of a central control shaft must be designed to withstand the reservoir head, and a transition is required both upstream and downstream of the gate passages. Foundation conditions and economic comparisons may dictate the choice between the intake tower and the central control shaft. Reservoir operating schedules may require the release of discharges under various heads and gate openings resulting in the pulsating flow condition ("burping") discussed in paragraph 2-4d. In some cases this undesirable condition can be eliminated by use of a central control shaft to shorten the conduit length downstream from the control gate. Further discussion of gate structure locations is given in EM 1110-2-2400.J

4-5. Submerged Intakes. The submerged intake is a comparatively simple and economical structure most often equipped with trash struts and bulkhead slots, having a streamlined entrance to the conduit or tunnel which is submerged at a low reservoir level. The submerged intake is satisfactory for reservoirs that function solely for flood control. However, when the intake will be permanently submerged by a conservation pool, difficulty arises in unwatering the conduit or tunnel upstream of the service gates. When bulkhead slots are located downstream from the intake face, provisions must be provided for closing the roof slot to prevent a high-velocity jet from entering through the slots and causing cavitation damages to the roof immediately downstream (item 20). Use of divers for bulkhead installation is to be avoided.

4-6. Combined Intake and Gate Structure. This is a common type of intake tower that usually requires a bridge for access, and gate wells are provided to accommodate the service and emergency gates. The emergency gate is upstream from the service gate and is utilized for inspection and maintenance of the service gate passage. The gate wells are

generally wet for low head, wet-dry combination for intermediate head, and dry for high head structures. Determination of the well type is from structural and mechanical design considerations. A float well is normally provided for installation of a reservoir stage recorder. Bubbler gages are also used for this purpose and require less space. It is desirable to have two or three separate levels for the float well intakes, and they should be away from any drawdown effects when releasing large flows.

4-7. Underground Control Structures. An alternative to the conventional tower-type structure is an underground control structure buried beneath the embankment or in the abutment with a downstream access gallery. The access gallery should be placed adjacent to and at the same elevation as the water passages, essentially forming a multiple-box structure. Horizontal air vents will require check valves to prevent flow of water through them. The underground gate structures may be more economical than the conventional tower-dry well structure for high operating heads (>150 ft). Another economical advantage of this type of structure is the elimination of the service bridge which is required for a tower structure. Other conditions under which an underground structure should be considered include projects where water quality releases do not require multiple intakes over a wide range of reservoir levels and where reservoir operation results in periodic drawdown of pool level to the top of the intake bulkhead structure. Structural considerations are discussed in item 83. This type of structure has been used by others and by the Corps at the Fall Creek Dam in the Portland District and the New Hogan Dam in the Sacramento District.

4-8. Downstream Control Structures. Flow control facilities located at the downstream end of a conduit, when closed, subject the entire conduit to the full reservoir head and the possibility of high pressure leaks, piping along the conduit, and subsequent failure of the embankment. Therefore special design precautions are necessary when the control structure is located at the downstream end of the outlet conduit. The conduit between the impervious cutoff and the control structure may be a freestanding steel conduit housed in a concrete-lined tunnel of sufficient size to permit access for maintenance. This type of construction is frequently used for penstocks through embankments. Outlet facilities with downstream control must also have an emergency gate upstream of the steel conduit and stop log provisions at the conduit entrance. Provisions must be made for continued releases as required during shut-downs of primary release facilities.

4-9. Gate Passageway Requirements. The requirements discussed for sluice gates in paragraph 3-12 also apply to control gates for conduits

through embankment dams. Normally a service gate, an emergency gate, and slots for bulkheads or stop logs should be provided for each gate passage to the conduit or tunnel. The total flow cross-sectional area of gate passages should exceed the downstream conduit area by 10 to 15 percent. Typical gate installations for both tainter and vertical-lift gates are shown in plate C-36.

4-10. Low-Flow Releases. The operation of large gates at small openings (<0.5 ft) is not recommended because of the increased potential for cavitation downstream from the gate slot. In cases where low-flow releases are required, consideration should be given to low-flow bypass culverts, center pier culverts, multilevel wet well facilities (see Chapter 6), or a low-flow ("piggy-back") gate incorporated in the service gate.

Section III. Entrance Shapes

4-11. General. The general design of entrance shapes, discussed in paragraph 3-6, is equally applicable to conduits for embankments and concrete dams although the structural setting and some details are different. Entrances in concrete dams are ordinarily constructed as bell mouths for circular conduits and with entrance curves at the top, bottom, and sides for rectangular conduits. In embankment dams, the conduit inverts are normally set at approximately the same elevation as the floor of the approach channel. Consequently, there is little curvature of the invert approach so that a bottom curve is not required. In the case of embankment dam intakes with two or more gate passages, there usually is insufficient lateral space for full bell-mouthed entrance curves on the sides, so that only the roof is bell-mouthed and the piers and sides are extended upstream to support the trash struts. The sides and piers are carefully transitioned from rounded noses to the gate passage. In the case of a single rectangular gate passage, the top and sides can be flared or treated as above.

4-12. Selection of Entrance Shape for Design. A comprehensive series of tests on flared entrances has been conducted at WES (item 76). Intake roof curves for conduits with fully suppressed intake inverts and limited lateral space for side flares should be designed as indicated in plate C-37. The short elliptical shape (fig. a, plate C-37) is satisfactory when the back pressure on the intake is great enough to prevent low local pressures. The long elliptical shape should be used when back pressure is not adequate to eliminate low local pressures (fig. b, plate C-37). The effects of upstream face geometry are given in HDC 221-2ⁿ and item 20. Intakes with sufficient lateral space for sidewall streamlining should have curves as shown in plate C-22 and discussed in paragraph 3-6c.

4-13. Linear Sidewall or Pier Flare. WES studies show that entrance roof pressure conditions for two-dimensional curves can be improved by tapering the divider piers. Plate C-38 shows the improvement of pressure conditions from using linear sidewall and/or pier flare. The computational procedure is illustrated in HDC 221-3 and 221-3/1. Two-dimensional roof curve pressure coefficients can be converted to three-dimensional coefficients for side flare by:

$$C_3 = C_2 \left(\frac{A_2}{A_3} \right)^2 \quad (4-1)$$

where

C = pressure drop coefficient

A = flow area in square feet at the point of interest

Subscripts 2 and 3 indicate two- and three-dimensional values, respectively. Unless model-tested, it is recommended that application of equation 4-1 be limited to the cases where the horizontal flare does not exceed 1 horizontally to about 12 longitudinally.

Section IV. Control Gates

4-14. General. The types of gates and valves and their operating characteristics discussed in paragraphs 3-8 to 3-17, are equally applicable to conduits for embankment dams. Generally, a service gate, an emergency gate, and slots for bulkheads or stop logs are provided for each gate passage to the conduit or tunnel (plate C-36). Cable-suspended tractor or hydraulically operated tractor or slide gates are normally used in conduits for embankment dams. The problems of determining the hydraulic forces acting on tractor gates, with emphasis on cable suspension, will be discussed in this section. Although downpull forces on a partially opened gate constitute a hoist design problem in both hydraulically operated and cable-suspended gates, the vibration problem is more critical in the design of cable-suspended gates. For this reason cable-suspended tractor gates are not recommended for flow regulation or for heads in excess of 150 ft.

4-15. Gate Lip Geometry. Laboratory and field tests have shown that the 45-deg gate lip design shown in plate C-23 performs satisfactorily under all flow conditions. The 45-deg lip should terminate in a 1-in.

15 Oct 80

vertical extension to ensure that the jet springs free from the upstream edge of the lip. The upstream face should be flat rather than "bellied" in order to have uniform flow conditions across the width of the conduit.

4-16. Vertical-Lift Gate Discharge Computations. Plate C-39 presents a suggested design discharge coefficient curve for use with equation 3-2 for developing rating curves for vertical-lift gates with 45-deg bottoms (plate C-23) and assuming free-surface flow downstream of the gate. Stage-discharge relations for selected gate openings and for free-surface flow downstream can be computed with CORPS H3201.^o Single gate passage structures of nominal length and reservoir head generally have downstream free-surface flow for gate openings up to 80 percent of the gate passage height. In multiple gate passage structures, this 80 percent value may be greatly reduced with two or more gates partially open. In any event, computation of the flow profile between the gate and conduit exit portal is necessary to ascertain the gate opening at which flow control shifts from the gate to the exit portal due to conduit friction for a given pool elevation, thus possibly causing flow pulsations ("burping") as discussed in paragraph 2-4d. Generally, the downstream conduit slope is mild and the flow profile will be the M_3 type (see plate C-1). Therefore, an initial depth in the downstream conduit proper must be estimated and the profile computation proceeds in the downstream direction. For a single passage structure, or for a multiple passage structure with balanced operation, it is recommended that this depth be estimated from the jet vena contracta and assume an energy loss between the gate and the conduit proper (transition loss) of 0.1 times the jet velocity head. For unbalanced gate operation, it is recommended to assume this energy loss at 0.2 times the average jet velocity head.

4-17. Commercial Gates. There are many commercially available slide gates, tainter gates, knife-gate valves, flap gates, etc., that are readily adaptable to low head and small discharge flood control and drainage projects. HDC 340-1ⁿ presents head loss coefficients for flap gates used extensively in flood protection and drainage projects. Pickett et al. (item 93) have compiled considerable data on discharge and head loss coefficients for various types of gates and valves.

4-18. Hydraulic Load for Vertical-Lift Gates.

a. General. The hydraulic load on the gate leaf should be determined both for gate closed and part gate operation. Hydraulic loads are computed in the usual manner with the gate closed and the reservoir at maximum level. The vertical hydraulic loads on the gate during partly open operation can be separated into upthrust on the bottom and

15 Oct 80

downthrust on the top as indicated in HDC 320-2.ⁿ The upthrust for 45-deg gate bottoms determined from model and prototype tests is shown in HDC 320-2/1.ⁿ Both slide gates and tractor gates are included. The unit upthrust load is in terms of the effective head on the gate. A similar type of graph for downthrust on the top of the gate is shown in HDC 320-2/2.ⁿ The data on downthrust are applicable only to gates with similar upstream and downstream clearances between the gate and the roof slot boundaries. HDC 320-2/3ⁿ presents a sample computation illustrating the use of HDC 320-2/1 and 320-2/2ⁿ in the solution of a hydraulic and gravity force problem. Additional hydraulic load data have been reported by Simmons, Naudascher et al., and Smith (items 113, 79, and 115, respectively). The occurrence of free-surface or full conduit flow downstream from the gate, the transition from either to the other, and the gate speed may have considerable effect on the hydraulic load.

b. Gate Catapulting. An intake gate is sometimes used for rapidly watering-up the penstock and turbine scroll case, or the space between the service and emergency gates, by simply opening the intake gate a few inches. As the space between the intake gate and downstream gate becomes full, the water may rise through an opening between the downstream side of the intake gate and the gate slot. If this back-of-gate opening area is smaller than the gate opening area, it may restrict the vertical flow of water into the gate slot. Under these conditions sufficient hydraulic forces on the gate have occurred at several projects that would abruptly raise or "catapult" the gate tens or even hundreds of feet up the slot (items 40 and 98).

4-19. Vibration of Cable-Suspended Gates. Thompson (item 121) treats the theory of vibration with the determination of whether any disturbing frequencies are inherent in the hydraulic system of a design that may approach the natural frequency of elements of the system (gates, valves, splitter piers, stilling basin walls, etc.). As the magnitudes and frequencies of the exciting hydraulic forces can only be approximated in most cases, it is necessary to effect conservative designs. Fortunately most of the exciting hydraulic forces have high frequencies and the natural frequencies of the various elements of the structure are very low. The case of an elastically suspended conduit gate is used to illustrate application of the theory.

a. Resonance. When the forcing frequency is exactly equal to the natural frequency a condition of resonance exists. The displacement amplitude for the vibrating system increases without bound and is governed only by the amount of damping in the system. This may result in structural rupture. The amplitude can also increase rapidly if there is

only a small difference between the forcing and natural frequencies.
The undamped magnification factor

$$\frac{x}{x_o} = \frac{1}{1 - \left(\frac{f_f}{f_n}\right)^2} \quad (4-2)$$

where f_f/f_n is the ratio of the forcing frequency to natural frequency, represents the factor by which the zero frequency deflection x_o of the spring-mass system under the action of a steady force must be multiplied to determine the amplitude x . It is desirable to produce a design with a low magnification factor.

b. Forcing Frequencies. Two possible sources of disturbing frequencies are the vortex trail shed from the bottom edge of a partially open gate and the pressure waves that travel upstream to the reservoir and are reflected back to the gate. The frequency of the vortex trail shed from a flat plate oriented with face perpendicular to flow direction can be defined by the dimensionless Strouhal number, S_t , as follows:

$$S_t = \frac{L_p f_f}{V} \quad (4-3)$$

where

L_p = plate width

f_f = vortex trail shedding frequency

V = velocity of the fluid

The Strouhal number for a flat plate is approximately 1/7. The forcing frequency of a vortex trail shed from a gate may be estimated as:

$$f_f = \frac{\sqrt{2gH_e}}{7(2Y)} \quad (4-4)$$

where

H_e = energy head at the bottom of the gate

g = acceleration due to gravity

Y = projection of the gate into the conduit or half of the plate width L_p

Unpublished observations of hydraulic models of gates have indicated that the vortex trail will spring from the upstream edge of a flat-bottom gate causing pressure pulsations on the bottom of the gate. The vortex trail springs from the downstream edge of a standard 45-deg gate lip, eliminating bottom pulsations. A more recent research study at Iowa (item 60) on flat-bottom gates indicates that the 45-deg sloping gate bottom used by the Corps should be free of vibration induced by vortices shed from the gate lip. The frequency of a reflected positive pressure wave may be determined from the equation:

$$f_f = \frac{C}{4L} \quad (4-5)$$

where

C = velocity of the pressure wave

L = length of the conduit upstream from the gate

The pressure wave velocity is dependent upon the dimensions and elastic characteristics of the pipe or of the lining and surrounding rock of a tunnel. Data are given in HDC 060-1/2ⁿ by Parmakian (item 90) for various combinations of these variables.

c. Natural Frequency. The natural frequency of free vertical oscillation of a cable-suspended gate can be expressed by the equation:

$$f_n = \frac{1}{2\pi} \sqrt{\frac{gE}{12l\sigma}} \quad (4-6)$$

where

E = modulus of elasticity of the cable

l = length of the supporting cable

σ = unit stress in the cable

d. Sample Computation. HDC 060-1/4 and 060-1/5th present sample computations illustrating the above theory.

Section V. Transitions

4-20. General. Transitions are required to effect changes in conduit size (expansions and contractions) and shape (rectangular to circular, circular to rectangular, etc.). They may be abrupt with high head loss or streamlined with small head loss depending upon the purpose. At Mica Dam abrupt expansions have been designed as in-line energy dissipators (item 104). Singh (item 114) has recently presented a procedure for designing a streamlined circular-to-rectangular transition resulting in essentially a straight-line variation in area effecting improved hydraulic performance. Transitions fall into three general categories: (1) entrance, (2) in-line, and (3) exit. In flood control conduits, transitions are used to connect a usually rectangular gate passage to circular- horseshoe- or oblong-shaped conduits. They are also used at conduit exits to help spread the flow prior to entering the energy dissipator. In sluices they are frequently used to effect exit portal constrictions, to increase sluice back pressure, and to spread the jet on the spillway face.

4-21. Entrance and Intake Transitions. Entrance transition design for both circular and noncircular inlets has been discussed in paragraph 3-6. Typical entrance transitions are shown in plates C-21, C-32, and C-33. From the data presented in these plates, it can be assumed that loss coefficients for well-designed simple entrances will not exceed one-tenth the conduit velocity head. In complex intakes, the entrance loss is included in the combined intake loss. Comparable entrance pressure data are given in plates C-22, C-37, and C-38.

4-22. In-Line Transitions.

a. Location. Water usually flows through several different passageways in its route from the reservoir to the river below the dam. Transitions have the function of providing a smooth change from one cross section to another in such a manner than hydraulic losses and cavitation

potential are minimized. Transitions are generally required at one or more of the following locations: (1) between the intake gate passage and the upstream end of a circular conduit, (2) upstream and downstream from a central control gate passage, and (3) at the outlet end of the conduit. If gate passages are the same height as the downstream conduit, double curvature of the transition fillets will be avoided.

b. Smoothness in Direction of Flow. A well-designed transition should provide a gradual change in area boundary shape. The transition boundaries should follow easy curves, with intervening tangents if required, and the curves should be well defined to facilitate construction. The maximum change in flow direction occurs along the path of convergence of the outside corners of the transition. The junction of the corners of the transition with the desired section downstream should be carefully checked to determine whether the desired curvature is obtained to prevent the occurrence of separation or negative pressures along corner boundary lines. Construction joints should not be located at or near the end of the transition. Since a negative direction change of boundary (away from the flow direction) reduces pressure, any misalignment of construction forms or subsequent small movement of monoliths on either side of a joint may further accentuate the drop in pressure and cause cavitation. (See item 7.)

c. Length. The required length of the transition as compared with the conduit diameter depends upon the lateral, vertical, and diagonal boundary changes. The number and arrangement of gate passages also affect the length of the transition. As the number of gate passages increases, the length of the transition generally increases. As a general rule, to eliminate the possibility of cavitation damage within and just downstream of the transition and to minimize head loss, the ratio of a contraction transition length to maximum radial offset from the outside boundary of the gate passage to the corresponding location on the conduit boundary should be about V/\sqrt{gD} (V and D being the average of the maximum average velocities and equivalent diameters at the beginning and end of the transition). However, for certain combinations of gates and tunnel sizes, this guideline may result in too severe contraction for low heads, in which case the length should be increased to reduce the angular rate of change along the transition. Thus, maximum angle of contraction or expansion relative to the conduit center line should be limited to about 7 deg. A sample computation for the design of transitions is presented in Appendix E. The procedure is applicable to all in-line transitions.

d. Pressure Gradients. A study should be made of the local average

pressure throughout the transition. Average pressures can be computed using the Bernoulli equation (eq 2-3) and the average pressure should be equal to or greater than atmospheric pressure. Pressure data in transitions may be found in items 68 and 132 for entrance and midtunnel transitions, respectively.

4-23. Exit Transition. Normally the shape (circular, horseshoe, oblong, etc.) of an outlet conduit or tunnel for embankment dams is maintained to the exit portal and the transition into the energy dissipator is made in an open channel downstream from the portal. When the embankment slope is relatively flat, the tunnel or conduit can be shortened by moving the transition upstream into the embankment and abruptly raising the roof to ensure free-surface flow in the transition. Design details of a typical outlet works exit transition are presented in Chapter 5.

CHAPTER 5

ENERGY DISSIPATION AND DOWNSTREAM CHANNEL PROTECTION

Section I. Energy Dissipators

5-1. General. The outlet flow, whether it be from the world's largest dam or from a small storm drain, usually requires some type of energy-dissipating structure to prevent downstream channel degradation. The design may vary from an elaborate multiple basin arrangement to a simple headwall design, depending upon the size and number of conduits involved, the erosion resistance of the exit channel bed material, and the duration, intensity, and frequency of outlet flows. The structure(s) may consist of (a) abrupt expansions in high-pressure conduits (item 104), (b) hydraulic jumps in low-pressure conduits (item 130), (c) flip buckets, valves, and deflectors which spray high-velocity jets into the air before plunging into a downstream pool, and (d) conventional hydraulic-jump type stilling basins. The latter vary from sluice jets spreading on spillway faces and toe curves, to impact dissipators (item 46), to horizontal aprons with baffle piers and end sills (item 69). In many cases of low-pressure flow (storm drains, etc.), adequate dissipation of energy can be obtained by the use of riprap aprons, preformed scour holes (items 10 and 33), and other economical devices (item 34). This chapter treats in detail the design of the transition, hydraulic jump, and the rectangular cross-section stilling basin for a single conduit.

5-2. Hydraulic-Jump Type Stilling Basins.

a. General. The typical energy dissipator for an outlet works structure requires a stilling basin to produce a hydraulic jump. The stilling basin is joined to the outlet portal with a transition chute which has flared vertical sidewalls and a downward parabolic invert. Appendix F presents the procedure as set forth in this chapter for the design of outlet works stilling basin to include an illustration of a "low-level outlet with respect to tailwater" where an eddy problem may occur within the stilling basin for low and intermediate discharges.

b. Low-Level Outlets with Respect to Tailwater. The invert of the outlet portal of a conduit is "low" with respect to tailwater if for any operating discharge the d_2 curve intersects the tailwater for that discharge in the transition chute between the conduit and the stilling basin proper at a section where the slope of the chute invert is flatter than $1V$ on $6H$ (see plate C-40 for definition sketch, and items 85, 88, and 89). At several Corps installations such stilling basins performed adequately throughout the higher ranges of discharges; but at low and intermediate

flows, an eddy formed in the basin and downstream flow was confined to a narrow section along one of the sidewalls. Rocks and debris were trapped in the eddy and were moved upstream to the point at which they met the efflux from the conduit; here they were agitated and some were bounced violently against the apron as they were picked up by the issuing jet and moved downstream where they again were trapped in the eddy. This action resulted in impact and abrasion damage to the concrete apron, baffles, and sidewalls. Thus, the idealized example problems given in Appendix F illustrate the procedure to determine whether eddy problems may or may not occur. If eddy problems are likely to occur, the trajectory should be designed with an inverted V as shown in para 5-2d(3). This divides low flows down both sides of the stilling basin and prevents an eddy from forming until the tailwater becomes excessively high. A model study should be made if the above guidance cannot be followed or if the flow from the outlet portal is not "ideal" with a horizontal transverse water surface and a uniform, symmetric velocity distribution. (See also para 2-7 relative to submerged outlets.)

* c. Basic Considerations. Stilling basins are generally designed for optimum energy dissipation of controlled flows equal to the capacity of the outlet channel. Such flows usually occur for long periods of time and are the most critical to the life of the structure. Appreciably less than optimum performance can be accepted for higher flows of short duration as long as the jump is confined to the stilling basin. The design of stilling basins usually includes the following considerations: (1) the design discharge for the basin will exceed that for outlet works capacity and is recomputed assuming smooth pipe flow in the flood control conduit (see Moody diagram in plate C-4), design pool elevation, and negligible energy losses in the flow between the conduit exit portal and the stilling basin (see also para 2-18 relative to short conduits); (2) the minimum anticipated tailwater for the design discharge is used in establishing the basin floor elevation; (3) 0.85 to full d_2 downstream depth is recommended for design depending on the lateral distribution of flow as it enters the stilling basin, duration and frequency of high flows, foundation conditions, and submergence needed to minimize cavitation; (4) the riprap immediately downstream from the stilling basin is designed using the average velocity of the flow depth over the end sill; and (5) whether the conduit will operate in conjunction with spillway flows. In many instances, closure of the outlet works during spillway operation will effect appreciable economy in the outlet works stilling basin design.

d. Transition Chute.

(1) Sidewall Flare. The angle (ϕ) of the flared section between the projected conduit axis and the stilling basin sidewall is defined by the equation:

$$\phi = \tan^{-1} \left(\frac{1}{\Delta L} \right) \quad (5-1)$$

where ΔL is termed the flare ratio and represents the distance along the axis in the direction of flow for unit divergence. The sidewall flare should terminate at or upstream from the beginning of the stilling basin apron. If the flare ratio (ΔL) is too large, the length of chute between the outlet portal and the stilling basin becomes excessive. If the flare ratio is too small, the flow will not spread uniformly over the flared section and lateral nonuniform energy dissipation will occur in the stilling basin. In extreme cases two side rollers will form. Tests performed at the State University of Iowa (item 102) showed that the flare of a jet followed a curved path and was dependent upon the Froude number of the jet at the exit portal. Model studies with circular conduits indicate that a straight wall with a minimum flare ratio (ΔL) of twice the Froude number but not less than six produces a satisfactory design, i.e.,

$$\Delta L = 2 F = \frac{2V}{\sqrt{gD}} \quad \text{or} = 6, \text{ whichever is greater} \quad (5-2)$$

where

D = conduit diameter, ft

V = flow velocity at the exit portal, fps

This should also be satisfactory for rectangular conduit outlets. The transition chute sidewalls should be connected to the exit portal with a radius not less than five times the outlet diameter or height ($5D$) and the invert continued on conduit slope for the length of the corner fillets (see plate C-41). The length of the fillets for a circular conduit outlet transition should be approximately 1.5 times the conduit diameter or height ($1.5D$).

(2) Sidewall Restrictions and Abrupt Offsets. The possibility of a depressed pressure gradient throughout a conduit and subsequent more than normal discharge has been noted in laboratory and field tests. In model tests on an oblong-shaped conduit, side venting of the free-surface jet was apparently restricted by the sidewall design, and the energy gradient at the exit portal was depressed nearly to the conduit invert. The conduit shape was vertically oblong; the vertical sidewalls had a mitered flare (1 on

5.63) from the horizontal diameter; corner fillets were not provided at the intersection of the invert and sidewalls; and the transition invert curve was parabolic. Offsetting the walls laterally (1.5 ft on each side of the conduit) raised the pressure gradient and reduced the discharge; however, there was less satisfactory spreading of the jet into the stilling basin. Moreover, abrupt offsets result in flow riding up the sidewalls. Such effects on other conduit shapes have not been determined and this type of sidewall design should be avoided unless model-tested. These effects can exist at one discharge and disappear at either a higher or lower flow rate. (See Tuttle Creek data in plate C-3 and item 134.)

(3) Parabolic Drop. The profile of the transition chute invert from the outlet portal invert to the stilling basin floor is in the form of a parabolic curve based on the trajectory of a jet. The invert curve must not be steeper than the trajectory that would be followed by the high-velocity jet under the action of gravity, or the flow will tend to separate from the transition floor with resultant negative pressures. The floor profile should be based on the theoretical equation for a free trajectory:

$$y = -x \tan \theta - \frac{gx^2}{2(1.25 V_{sm})^2 \cos^2 \theta} \quad (5-3)$$

where

x and y = horizontal and vertical coordinates measured from the beginning of the curve, ft

θ = angle with the horizontal of the approach invert at the beginning of the vertical curve, deg

g = acceleration due to gravity, ft/sec²

V_{sm} = average velocity for smooth pipe flow at the beginning of the curve, fps

As a conservative measure to prevent separation of flow from the floor, the velocity (V_{sm}) in equation 5-3 has been increased 25 percent over the average flow velocity computed for smooth pipe flows. The trajectory should be joined to the stilling basin floor with a curve that has a radius equal to the entering depth, i.e., $R = d_1$. An outlet works stilling basin subject to low-flow eddies as discussed in para 5-2b should be designed

with an inverted V beginning at the exit portal and sloping upward on a 1V on 7.9H slope for a distance equal to the length of the fillet L_f . The height of the inverted V above the invert of the exit portal at a distance L_f from the outlet will be $0.19D$ as shown in Plate C-41A (where D = equivalent diameter of the conduit). Plate C-41A shows an elevation view and section of an outlet works stilling basin with an inverted V. The equation of the new parabolic trajectory along the center line of the basin formed by the addition of the inverted V can be computed by the equation:

$$y' = -C_m x^2 \quad (5-3a)$$

where y' and x are the vertical and horizontal coordinates measured from the beginning of the curve in feet. The center-line trajectory should intersect the floor of the stilling basin at the same distance downstream from the outlet as the ordinary trajectory. Thus, C_m for the center-line trajectory can be determined by using y' equal to the elevation at the beginning of the curve (outlet portal elevation + $0.19D$) minus the elevation of the stilling basin apron, and x equal to the distance from the beginning of the curve to its intersection with the stilling basin apron (same as ordinary trajectory).

e. Elevation of Stilling Basin Floor. The stilling basin is designed as an energy dissipating device for the flow from the outlet works conduits. Its purpose is to reduce the high-velocity outlet flow to permissible exit channel velocities. The energy dissipation phenomenon is the hydraulic jump. The formula for a hydraulic jump in a level, rectangular section is:

$$\frac{d_2}{d_1} = \frac{1}{2} \left(\sqrt{1 + 8 F^2} - 1 \right) \quad (5-4)$$

where

d_1 and d_2 = sequent depths

F = Froude number of the flow entering the jump, i.e.,

$$F = \frac{V_1}{\sqrt{gd_1}} \quad (5-5)$$

where V_1 and d_1 are the average flow velocity and depth, respectively, of the entering flow. It is of value for the designer to examine the type of jump to be expected with the Froude number involved. Chow (item 17) presents a discussion on the types of jump to be expected with various magnitudes of Froude numbers. The stilling basin design flow (generally, maximum discharge through the outlet channel) is used in determining the elevation of the basin floor. A floor elevation may be assumed in the case of a drop from the conduit outlet and the corresponding depth and velocity of flow entering the basin computed using Bernoulli's equation and neglecting energy loss between the conduit outlet portal and the stilling basin. This depth and velocity are used to compute the Froude number (F). The depth of tailwater required to form a jump is computed as d_2 . The required depth (d_2) is then compared with the available depth (obtained from a tailwater rating curve) and the floor elevation assumption adjusted accordingly. Laboratory investigations have demonstrated that in the range of Froude numbers (F) from 4 to 10, a satisfactory hydraulic jump can be made to form in a stilling basin with end sill and baffle blocks by a tailwater that produces 0.85 of the theoretical d_2 . The adequacy of the tailwater curve to fit d_2 values for flows less than the design discharge should also be checked. If downstream degradation is likely to occur after construction, estimates should be made of the possible lowering of the tailwater curve and the lowest expected tailwater curve should be used in designing the stilling basin. If the natural tailwater depth is greater than the computed d_2 depth (see para 5-2b), the length of the jump and position of the jump toe on the curved invert should be determined using HDC sheets and charts 124-1 and 124-1/1.^h If the basin floor is to be level with the conduit invert, equations 5-2 and 5-4 may be combined in a manner to relate the stilling basin width and depth for convenience in an economic study.

f. Basin Width. The effect of increasing the stilling basin width is to reduce the required depth of basin. Basically, the problem is an economic one in which various combinations of width and depth of basin are compared to obtain the least cost combination. (Also see para 5-2d(1) above.)

g. Basin Length. Basically, the length of a stilling basin is predicated on the length of the hydraulic jump for which it is designed. For basins with Froude numbers (F) exceeding 3 and less than 12, a length of $3d_2$ is recommended. Longer basins should be considered when Froude numbers (F) exceed 12 due to the magnitude of residual energy leaving the basin. When the outlet channel is located in rock (item 17), a basin length of $2.5d_2$ may be adequate. A basin length of $3.5d_2$ to $4.0d_2$ should be

considered for highly erodible outlet channels. Stilling basins without baffle piers and end sills should have paved apron lengths of $4d_2$ to $5d_2$.

h. Baffle Piers. Baffle piers on the apron should have a height of d_1 or $1/6d_2$, whichever is less. They should be located $1.5d_2$ downstream from the toe of the transition chute for entering velocities ≤ 60 fps with Froude numbers of 3.5 to 6.0. For higher velocities they should be moved farther downstream. A second row of baffle piers is very effective in reducing scour downstream from the stilling basin. If the basin apron elevation is placed such that existing tailwater produces 85 to 90 percent of d_2 , a second row of baffle piers is recommended. The second row should be approximately $0.5d_2$ downstream from the first row. The width and spacing of piers should be equal to or slightly less than their height (d_1). A distance of at least half of a pier width should be allowed between the end piers and the basin walls (see plate C-41). Velocities against the face of the baffles can be estimated from HDC 112-2/1.ⁿ

i. End Sills. Sloping end sills (1V on 1H) are preferable to vertical end sills because their self-cleaning characteristics reduce damage from trapped rocks and debris. However, they impart a vertical component to the bottom exit velocity increasing the intensity of the bottom backroller immediately downstream. End sill height of half of the baffle height is recommended (see plate C-41). Riprap at the downstream end of the stilling basin should be lower than the top of the end sill. This will help prevent backrollers from pulling rock into the basin which can cause concrete abrasion damage.

j. Training Walls. Vertical parallel training walls are recommended. Walls with as little as 4V-on-1H batter can create downstream eddies. The top of the stilling basin walls should be at the maximum tailwater elevation that may occur during operation of the outlet work in order to prevent side flow onto the hydraulic jump. Any higher tailwater resulting from spillway flows during outlet works operation must be considered, although such combined operation is not recommended. The exit transition flare should not be carried through the stilling basin. Freestanding training and dividing walls are designed to withstand static loads due to turbulence in the hydraulic jump. The static load is usually assumed to be that resulting from maximum tailwater on one side of the freestanding wall and no water against the opposite wall. A stilling basin with a high entering Froude number flow ($F > 10$), foreshortened by virtue of baffle blocks and high end sill, has very violent turbulence. This dynamic loading created by the jump cannot be easily computed and where such loading is critical, model testing

Change 1
15 Mar 87

is recommended. Results of a study of pressure fluctuations in model stilling basin sidewalls is reported in item 35 and prototype tests results in item 48.

k. Wing Walls. Wing walls are usually not required if the exit channel invert is made at least $0.3d_2$ wider than the stilling basin and wrap-around side slopes are provided (plate C-42). Quadrant wing walls at the end of stilling basins are effective in protecting the exit channel invert against scour. However, they permit more attack on the channel side slopes than freestanding basin walls with wraparound offset slopes.

l. Multiple Basins. Where more than one conduit discharges into a common outlet channel (items 124 and 126), the dividing wall or walls between basins should be sufficiently high to prevent side flow into a basin over the dividing wall when the adjacent conduit is not operated. Efficiency of the operating basin can be appreciably reduced by this flow. Whenever possible, operating schedules should provide for equal discharge from all conduits or symmetrical operation of conduits. The stilling basin design should be based on the tailwater with all conduits discharging their design flows. However, the design should be checked for design flow operation of a single conduit to be sure that the reduced tailwater is sufficient to hold the jump in the basin. Under this condition of operation a tailwater depth equal to $0.85d_2$ may be acceptable. The stilling basin design should ensure satisfactory energy dissipation for all anticipated conditions of operation. In such cases the designer must exercise considerable judgment and a model study may be desirable. Dynamic loading of the dividing wall(s) may be significant.

m. Dewatering Sumps. Dewatering sumps are required in the floor of all outlet works stilling basins to facilitate dewatering for inspection and maintenance. It is recommended that the sump be located close to the training wall in the low-velocity area between the baffle piers and the end sill and that the stilling basin floor have a slight slope toward the sump. When practical, drainpipes should be provided to alleviate standing water and to reduce pumping costs during inspections.

5-3. Low-Head Structures. Many types of energy dissipators have been developed for low-head outlet structures such as outfall storm sewers, drainage culverts, farm ponds, low dams, etc. (items 137 and 139).

a. Impact Energy Dissipator. The impact energy dissipator (items 46 and 139) is an effective stilling device even with deficient tailwater. Dissipation is accomplished by the impact of the incoming jet on a fixed, vertically hung baffle and by eddies formed by changes in direction of the jet after it strikes the baffle. Best hydraulic action occurs when the

tailwater approaches, but does not exceed, a level halfway up the height of the baffle. The impact basin is recommended for outflow velocities between 2 and 50 fps. The dimensions of this energy dissipator in terms of its width are given in HDC 722-2.ⁿ

b. Stilling Wells. (Items 46 and 133.) Energy dissipation from a sloping conduit can be accomplished by expansion in an enlarged vertical stilling well, by the impact of the fluid on the base and walls of the stilling well opposite the incoming flow, and by the change in momentum resulting from redirection of the flow. The top of the well is usually set flush with the outlet channel. Its action is essentially independent of tailwater and WES tests indicate that it performs satisfactorily for discharge-pipe diameter ratios ($Q/D^{2.5}$) up to 10 with a stilling well-inflow pipe diameter ratio of 5. Q is the conduit flow in cubic feet per second and D is the conduit diameter in feet. Pertinent design information is given in HDC 722-1.ⁿ

c. Impact-Jump Basin. (Items 9 and 46.) The impact-jump basin was developed by the U. S. Department of Agriculture for small dams and achieves energy dissipation through impact on baffle piers and end sill in addition to that accomplished in an incomplete hydraulic jump. It involves a very short apron with chute blocks, baffle piers, and end sill. Basin widths greater than three times the conduit diameter have proven unsatisfactory for $Q/D^{2.5}$ greater than 9.5. Tailwater depth equal to at least $0.85d_2$ is required for acceptable performance. HDC 722-3ⁿ presents design dimensions in terms of the entering flows having velocities less than 60 fps and Froude numbers between 2.5 and 3.5.

d. Flared Outlet Transitions. Economical energy dissipation and scour control can be accomplished by a paved horizontal apron at a culvert outlet for discharge-conduit diameter ratios ($Q/D^{2.5}$) up to 5. Appreciable additional energy dissipation is obtained by setting the apron at an elevation up to 0.5 conduit diameters below the exit portal invert and adding an end sill of appropriate height. The necessary dimensionless design information is presented in item 34.

e. Riprap Energy Dissipators. Riprap energy dissipators for storm drain outlets have been developed by WES (items 10 and 33) for both horizontal aprons and preformed scour holes. This type of energy dissipator is adaptable to regions where riprap in the required sizes, gradation, and quantity is readily and economically available. The necessary information for sizing these structures can be computed using HDC 722-4 and 722-5.ⁿ The required D_{50} riprap stone size can be estimated using HDC 722-7.ⁿ The

major dimensions of unprotected scour holes and the riprap size and horizontal blanket dimensions can be computed with CORPS H7220.

Section II. Outlet Channel

5-4. General. The function of the outlet channel is to connect the outlet works to the downstream river channel. The flow leaving an outlet works energy dissipator is generally highly turbulent, and contains inverse velocity gradients and large surface waves. Provisions are recommended for an enlarged channel immediately following the hydraulic structure in which the flow can expand and dissipate excess energy. Generally, a riprapped-lined trapezoidal channel provides this function. Model tests (items 45 and 77) have demonstrated the advantages in providing for or performing a "scour hole" in which the flow can expand and dissipate its excess energy in turbulence rather than in direct attack on the channel bottom and sides. A relatively small amount of expansion, preferably both vertically and horizontally, will greatly reduce the severity of attack on the channel boundaries. This makes it possible to stabilize the channel with rock of an economical size and provide additional factors of safety against riprap failure and costly maintenance (plate C-43). The provision of recreation facilities should be a consideration in the outlet channel design; for example, preformed scour holes provide areas of good fishing. Tailwater at the stilling basin should also be a consideration; and if feasible, the channel should be designed so that the tailwater curve will, as nearly as practical, approximate the d_2 curve for the full range of flows.

Response time of tailwater to increase with increases in the outflow discharge may also be a factor. Avoid using a "perched" outlet channel spilling into a lower river channel in erodible material.

5-5. Riprap. Determination of the D_{50} size of riprap for the channel sides to a distance of $10d_2$ downstream from the upstream end of a stilling basin should be made in accordance with the guidance given in HDC 712-1ⁿ using the average flow velocity leaving the stilling basin. Beyond this point, channel riprap design based on EM 1110-2-1601^h should be used. A riprap transition between the two riprap design sections is recommended. As riprap creates locally high boundary turbulence, a transition zone preceding the natural channel surface should be provided. This zone should have a length of three times the flow depth with a gradual downstream reduction in the D_{50} stone size. Design of exit channel riprap should provide protection against waves as well as velocity; therefore, reduction in stone sizes at upper levels is not recommended. All riprap gradation should be in accordance with EM 1110-2-1601.^h Additional information is given in item 84.

5-6. Side-Slope Erosion. As noted in paragraph 5-2k, a quadrant wall connecting the training wall at the end of stilling basin to the channel bank has been found effective in protecting the floor of the exit channel against scour. However, this wall permits more severe attack on the side slopes of the outlet channel than does a training wall terminated at the end sill extended straight downstream as a freestanding wall. Therefore, except on noneroding beds and banks, the training walls should terminate at the end sill and the toe of the side slopes should be offset at least $0.15d_2$ from the bottom of the outlet channel $0.3d_2$ wider than the stilling basin (plate C-42). Furthermore, the original streambed load should be considered in the outlet channel design. The bed load is cut off by the dam, resulting in possibly more erosion downstream. Consideration should be given to making the outlet channel wider and lower in an area with erodible soil, as with a preformed scour hole.

CHAPTER 6

SELECTIVE WITHDRAWAL STRUCTURES

6-1. Types. Selective withdrawal structures fall into three general types: (a) inclined intake on a sloping embankment; (b) freestanding intake tower, usually incorporated into the flood control outlet facilities of embankment dams; and (c) face-of-dam intake, constructed as an integral part of the vertical upstream face of a concrete dam. The appropriate type of intake structure for a given project depends on a number of considerations including reservoir size, degree of stratification, discharge rates, water quality objectives, need for flow blending between withdrawal levels, and project purposes. Types (b) and (c) predominate at Corps projects. A description of the design and operation of each type is presented by Austin et al. in item 5 (see plate C-44). The most common type of selective withdrawal structure is (b), the freestanding intake. Three general types of freestanding intakes predominate. The first consists of a flood control passage and weirs or ports in a single collection well. This type is generally appropriate for shallow reservoirs with minimum stratification where single weir or port operation is anticipated and blending between intakes is not required. The second is the dual wet well structure which consists of a flood control passage and two collection wells. This type is generally appropriate for reservoirs expected to exhibit strong stratification where anticipated operations for water quality objectives indicate that the capability for blending between intakes is desirable. In both the single and dual collection well systems the selective withdrawal capacity is generally less than the flood control capacity. The third is one through which all discharges, except spillway, can be released. For all types of selective withdrawal structures, the withdrawal device usually consists of one or more ports or weirs, or a combination of the two. The weir(s) can have a fixed elevation or variable elevation.

6-2. Design.

a. State of the Art. Each individual reservoir exhibits unique water quality and hydrodynamic characteristics and therefore it is difficult to provide general information pertinent to the design and operation of outlet structures for water quality control of reservoir releases. Water quality control structures can be used in a variety of situations including single purpose and multipurpose projects. The design of a water quality control structure requires an understanding of the mechanics of stratified flow, water quality and hydrologic considerations, and hydraulic design requirements. A general description of the

zone of withdrawal from a stratified body of water for single and simultaneous multilevel releases has been described in item 12. Requirements for water quality and hydrologic investigations necessary to design water quality structures are given in EM 1110-2-1402. Several examples of physical and mathematical model studies that have been conducted to design water quality structures from a water quality and hydrologic standpoint are given in items 26, 27, 28, 36, 61, 62, and 67. The principles of design given in this manual apply to the hydraulic design of water quality structures. Many needed design principles have yet to be established and in many cases, economic considerations dictate the design. This section summarizes a number of designs and design problems that have been investigated with physical models.

b. Design Information. Water quality outlet structures naturally divide into three parts: (1) inlets and collection well(s), (2) control gate passage(s), and (3) exit passage(s). Presently available pertinent design information is summarized in the following paragraphs.

(1) Inlet Ports. The capacity of ports and collection wells is based on water quality and hydrologic considerations. Additionally, the port size and geometry affect selective withdrawal characteristics. Inlet ports to water quality collection wells are designed to operate fully open or closed. Total flow is regulated by a downstream control gate. Ports should be operated under submerged flow conditions. Free flow conditions should be avoided. Ports are generally placed directly facing the upstream direction. Placing inlet ports vertically above each other can result in interference of operating equipment. Port velocities primarily affect trashrack design, flow stability, and collection well turbulence. Velocities of 4 to 6 fps or lower are recommended for normal operation, but designs with velocities up to 20 fps may be possible with hydraulic model studies (item 68) of conditions where fine control of selective withdrawal is not a governing consideration. Inlet ports operating under appreciable submergence with relatively low velocity can be expected to be cavitation-free. However, their entrances should be bell-mouthed for efficient inflow conditions. The entrance curves terminate possibly with a short tangent section at the inside vertical walls of the collection well where the gate is located. Inlet ports should be provided with trashracks to prevent debris from entering the collection well. Since inlet port gates are not normally subject to cavitation pressures, they do not require venting. Upstream bulkhead slots or other provisions for maintenance and repairs are required. These slots may also be used for trashracks.

(2) Inlet Weirs. An inlet port that is not totally submerged

can be operated as an inlet weir provided sufficient flow constriction is maintained by a downstream control gate so that submerged weir flow results. Without sufficient flow constriction, flow control may shift between the inlet weir and the control gate, causing a flow instability. Inlet weirs should always have trashracks to prevent debris floating on the water surface from entering the structure. If the release of surface water is desired most of the time, a structure may be designed to be operated specifically as an inlet weir. The crest of such a weir is usually thin and vertical, thus allowing movable bulkheads or a selector gate (variable position, mechanically actuated gate) to serve as a movable weir so that upper pool releases can be made for varying pool elevations. The weir flow should be submerged with flow control maintained downstream. Entrance velocities should be within the range of 4 to 6 fps and are normally governed by selective withdrawal considerations. The depth of flow over the weir and the weir length are sized to provide the required discharge and release water quality objective.

(3) Collection Wells. Collection well geometry and size are dependent upon the number, size, and spacing of inlets and vary appreciably from project to project. The primary purpose of a collection well is to provide a tower facility for the inlets and their gates. The collection well also serves as a junction box where the flow direction changes from horizontal to vertical to horizontal. Sometimes the flow direction changes can result in appreciable surging and head loss. Equipment in the collection well should be securely anchored. Damage to ladders in the collection well at Nolin Dam has occurred with 2- to 5-ft surges occurring with a 3-ft head differential from the pool elevation to the water-surface elevation in the wet well. Head losses that normally occur in the intake are the intake loss, velocity head through the inlet, friction in the well, entrance loss to service gate passage, and the velocity head of the vertical velocity in the well when the service gate passage is at an angle to the collection well. Blending of flows for water quality purposes should be done by blending flows from separate wet wells in a dual wet well system. Each wet well should have individual flow control, and inlet(s) at only one elevation should be open in each wet well. Experience has shown that erratic blending due to flow instability between inlets in separated wet wells may occur where the wet wells are connected and only a single service gate and gate passage are provided for flow regulation.

(4) Outflow Passages. Water quality outflow passages are usually very short and operate with free-surface flow except sometimes for the maximum design flow. In concrete gravity dams they may be located in the nonoverflow section and discharge through the sidewall of the stilling basin (plate C-45). They may also be located on the

15 Oct 80

upstream face of the dam and discharge onto the spillway. Water quality facilities for embankment dams are most frequently incorporated in the intake towers of the flood control outlet works and discharge into the flood control conduit. In multiple flow passage flood control intakes, the water quality releases can be made through the intake dividing pier (plate C-46), through bypass pipes around the service gate (plate C-47), or through the emergency gate well (plates C-47 and C-48). In the latter case, the flood control service gate is used to regulate the water quality flow release discharge.

(5) Submerged Weirs. Submerged weirs upstream of outlet works (plate C-49) can be used to prevent withdrawal of bottom waters from reservoirs by flood control conduits and penstocks (items 11 and 32). The principles involved have been studied and reported by WES (item 12). Local topography, flow requirements, and adjacent structures have appreciable effect upon the performance of these weirs. Therefore, a model study to determine the selective withdrawal characteristics is recommended where an upstream submerged weir is included in the project design.

6-3. Flow Regulation. Flow regulation is accomplished by means of a control gate(s) located in a uniform conduit section(s) downstream from the collection well(s). The gate passage section can be connected to the bottom of the collection well by a bell mouth or by a long radius elbow. In either case, pressures in this transition should be carefully studied in accordance with guidance in paragraph 2-16. Since the gate normally operates under little or no back pressure, it is essential that the issuing jet be adequately vented. Discharging the gate jet into an enlarged section with venting all around should be considered. Venting should be provided in accordance with the guidelines presented in paragraph 3-17.

6-4. Model Investigations.

a. Concrete Gravity Dams. A water quality outlet design for a concrete gravity dam is shown in plate C-45. Qualitative model tests of this design were made at WES (item 1). The location of the water quality tower adjacent to the left abutment of the spillway resulted in undesirable flow contraction around the tower with spillway flows in excess of 25,000 cfs. Preliminary tests of the water quality inlet orifices indicated that their elevation and size were not capable of meeting the required withdrawal characteristics. Model tests were also conducted on the multiple penstock intake structure at the proposed Dickey Dam (plate C-50). These tests were conducted to determine the selective withdrawal characteristics of this structure (item 26). The Dickey Dam will consist of two earthen embankments with the multiple penstock

intake structure located in the concrete gravity section. The intake structure will have individual collection wells connected to each of five 27-ft-diam penstocks. The level of withdrawal of flow into the collection wells will be controlled by the location of the top of the movable selector gates. The selector gates will function as a variable crest elevation submerged weir.

b. Embankment Dams. Five model-tested earth dam water quality control structure designs are shown in plates C-46, C-47, C-48, C-51, and C-52. The Beltzville design (plate C-46) releases the water quality flows into the flood control conduit through an outlet with its exit portal in the nose of the dividing pier of the flood control intake tower. At New Hope Dam, renamed B. Everett Jordan Dam, (item 70), the emergency gate well serves as the water quality collection well (plate C-48). The flood control regulating gate serves as the water quality regulator. When the emergency flood control gate is closed, water quality releases pass from the collection well into the flood control gate passage and under the regulating gate. Model tests showed the need to limit service gate openings to a maximum of 34 percent of fully open for water quality releases to prevent serious negative pressures in the throat section between the collection well and the flood control gate passage. The Taylorsville design (plate C-47, and item 25) has dual collection wells similar to the New Hope (B. Everett Jordan) design. During selective withdrawal operation, the emergency gates will be closed and flow will be discharged through the multilevel intakes into the wet wells and through an opening or throat located in the roof of the gate passages between the emergency and service gates. The service gates will be used to regulate the selective withdrawal releases. Additionally, an 18-in.-diam pipe bypass around each service gate will be provided to regulate the release of low flows with the service gates closed. Similar to the model tests of the New Hope (B. Everett Jordan) structure, tests of the Taylorsville structure also showed the need to limit service gate openings for water quality releases. For the Taylorsville structure, service gate openings greater than 55 percent of fully open resulted in negative pressures in the throat section. The DeGray design (plate C-51) consists of a single four-sided intake tower equipped with multilevel openings and a cylindrical gate (item 14). This structure provided selective withdrawal capability for both flood control and hydropower releases. The tower has two bulkheads and a trashrack in a single set of gate slots in each of its four sides. Placement of the trashrack panel determines the withdrawal elevation. The cylindrical gate in the intake tower is not operated as a flow control device. Flow passes vertically from the intake tower through a 21-ft-radius elbow into a 1205-ft-long, 29-ft-diam conduit. The conduit is bifurcated to provide for flood control and power generation releases. The flood

EM 1110-2-1602
15 Oct 80

6-4b

control releases are regulated at the end of the bifurcated conduit so that releases for both flood control and power generation can be drawn concurrently through the intake tower. Model tests were conducted on the water quality outlet structure at Beech Fork Dam (plate C-52) primarily to evaluate the effects of local terrain on the water quality performance of the outlet works (item 42). The structure has dual collection wells, each with 30-in.-diam conduits and control valves that release water quality flows into the flood control conduits immediately downstream of the flood control service gates.

15 Oct 80

APPENDIX A

BIBLIOGRAPHY

1. Ables, J. H., Jr., and Boyd, M. C. 1970 (Jun). "Spillway and Outlet Works, Rowlesburg Dam, Cheat River, West Virginia; Hydraulic Model Investigation," Technical Report H-70-7, U. S. Army Engineer Waterways Experiment Station, CE, Vicksburg, Miss.
2. Ables, J. H., Jr., and Pickering, G. A. 1973 (Feb). "Outlet Works, Warm Springs Dam, Dry Creek, Russian River Basin, Sonoma County, California; Hydraulic Model Investigation," Technical Report H-73-3, U. S. Army Engineer Waterways Experiment Station, CE, Vicksburg, Miss.
3. American Society of Mechanical Engineers. 1958. "American Standard Letter Symbols for Hydraulics," ASA Y10-1958, New York.
4. Anderson, A. G. 1947 (Aug). "Fluid Flow Diversion; A Summary and Bibliography of Literature," Project Report No. 1, St. Anthony Falls Hydraulic Laboratory, University of Minnesota, Minneapolis, Minn.
5. Austin, G. H., Gray, D. A., and Swain, D. G. 1969 (Nov). "Multi-level Outlet Works at Four Existing Reservoirs," Journal, Hydraulics Division, American Society of Civil Engineers, Vol 95, No. HY6, Proc Paper 6877, pp 1793-1808.
6. Ball, J. W. 1959 (Oct). "Hydraulic Characteristics of Gate Slots," Journal, Hydraulics Division, American Society of Civil Engineers, Vol 85, No. HY10, pp 81-114.
7. _____. 1963 (Sep). "Construction Finishes and High-Velocity Flow," Journal, Construction Division, American Society of Civil Engineers, Vol 89, No. C02, Paper 3643, pp 91-110.
8. _____. 1970 (Aug). "Cavitation Design Criteria," Control of Flow in Closed Conduits, Proceedings of the Institute, held at Colorado State University, Ft. Collins, Colo., 9-14 Aug 1970, pp 379-416.
9. Blaisdell, F. W. 1959 (Apr). "The SAF Stilling Basin," Agricultural Handbook No. 156, Agricultural Research Service and St. Anthony Falls Laboratory, Minneapolis, Minn.

15 Oct 80

10. Bohan, J. P. 1970 (Jan). "Erosion and Riprap Requirements at Culvert Storm-Drain Outlets; Hydraulic Laboratory Investigation," Research Report H-70-2, U. S. Army Engineer Waterways Experiment Station, CE, Vicksburg, Miss.
11. _____. 1970 (Feb). "Water Temperature Control Weir for Meramec Park Dam, Meramec River, Missouri; Hydraulic Model Investigation," Technical Report H-70-1, U. S. Army Engineer Waterways Experiment Station, CE, Vicksburg, Miss.
12. Bohan, J. P., and Grace, J. L., Jr. 1973 (Mar). "Selective Withdrawal from Man-Made Lakes; Hydraulic Laboratory Investigation," Technical Report H-73-4, U. S. Army Engineer Waterways Experiment Station, CE, Vicksburg, Miss.
13. Bradley, J. N., and Thompson, L. R. 1951 (Mar). "Friction Factors for Large Conduits Flowing Full," Engineering Monograph No. 7 (Revised 1965), U. S. Bureau of Reclamation, Denver, Colo.
14. Bucci, D. R. 1965 (Jul). "Outlet Works, DeGray Dam, Caddo River, Arkansas; Hydraulic Model Investigation," Technical Report No. 2-684, U. S. Army Engineer Waterways Experiment Station, CE, Vicksburg, Miss.
15. Bucci, D. R., and Murphy, T. E. 1965 (Mar). "Spillway and Sluices, Red Rock Dam, Des Moines River, Iowa; Hydraulic Model Investigation," Technical Report No. 2-673, U. S. Army Engineer Waterways Experiment Station, CE, Vicksburg, Miss.
16. Campbell, F. B., and Pickett, E. B. 1966 (Nov). "Prototype Performance and Model-Prototype Relationship," Miscellaneous Paper No. 2-857, U. S. Army Engineer Waterways Experiment Station, CE, Vicksburg, Miss.
17. Chow, V. T. 1959. Open-Channel Hydraulics, McGraw-Hill, New York.
18. Colebrook, C. F. 1939. "Turbulent Flow in Pipes with Particular Reference to the Transition Region Between Smooth and Rough Pipe Laws," Journal, Institution of Civil Engineer, London, Vol 11, pp 133-156.
19. Cox, R. G. 1973 (Jan). "Resistance Losses in Noncircular Flood Control Conduits and Sluices," Miscellaneous Paper H-73-1, U. S. Army Engineer Waterways Experiment Station, CE, Vicksburg, Miss.

15 Oct 80

20. Cox, R. G., and Chu, Y.-H. 1969 (Sep). "Characteristic Pressure Distribution in Outlet Works Intakes," Miscellaneous Paper H-69-8, U. S. Army Engineer Waterways Experiment Station, CE, Vicksburg, Miss.
21. Crandall, S. H., Vigander, S., and March, P. A. 1975 (Nov). "Destructive Vibration of Trashracks Due to Fluid-Structure Interaction," Journal of Engineering for Industry, American Society of Mechanical Engineers, Paper No. 75-DET-63, p 1359.
22. Creager, W. P., and Justin, J. D. 1950. Hydroelectric Handbook, 2d ed., Wiley, New York.
23. Dann, H. E., Hartwig, W. P., and Hunter, J. R. 1964 (Oct). "Unlined Tunnels of the Snowy Mountains Hydro-Electric Authority, Australia," Journal, Power Division, American Society of Civil Engineers, Vol 90, No. P03, Paper 4071, pp 47-79.
24. Davis, C. V., and Sorensen, K. E. 1969. Handbook of Applied Hydraulics, 3d ed., McGraw-Hill, New York.
25. Dortch, M. S. 1975 (Aug). "Outlet Works for Taylorsville Lake, Salt River, Kentucky," Technical Report H-75-12, U. S. Army Engineer Waterways Experiment Station, CE, Vicksburg, Miss.
26. Dortch, M. S., et al. 1976 (Dec). "Dickey-Lincoln School Lakes Hydrothermal Model Study; Hydraulic Laboratory Investigation," Technical Report H-76-22, U. S. Army Engineer Waterways Experiment Station, CE, Vicksburg, Miss..
27. Drummond, G. R., and Robey, D. L. 1972 (Apr). "Heat Budget Analysis and Development of Design Criteria for Selective Withdrawal Outlets, Taylorsville Lake, Kentucky," Special Report No. 2, U. S. Army Engineer Division, Ohio River, Cincinnati, Ohio.
28. _____. 1972 (Nov). "Heat Budget Analysis and Development of Design Criteria for Selective Withdrawal Outlets, Stonewall Jackson Lake, West Virginia," Special Report No. 4, U. S. Army Engineer Division, Ohio River, Cincinnati, Ohio.
29. Elder, R. A., and Dougherty, G. C. 1950 (Nov). "Hydraulic Characteristics of Howell-Bunger Valves and Their Associated Structures," Tennessee Valley Authority, Norris, Tenn.

EM 1110-2-1602

15 Oct 80

30. Fagerburg, T. L. 1977 (May). "Pressure Tests in Flood-Control Conduit, Melvern Dam, Kansas," Miscellaneous Paper H-77-5, U. S. Army Engineer Waterways Experiment Station, CE, Vicksburg, Miss.
31. Fletcher, B. P. 1969 (15 Jan). "Howell-Bunger Valves, Summersville Dam," Memorandum Report, U. S. Army Engineer Waterways Experiment Station, CE, Vicksburg, Miss.
32. _____. 1971 (Oct). "Spillway for Clarence Cannon Reservoir, Salt River, Missouri; Hydraulic Model Investigation," Technical Report H-71-7, U. S. Army Engineer Waterways Experiment Station, CE, Vicksburg, Miss.
33. Fletcher, B. P., and Grace, J. L., Jr. 1972 (May). "Practical Guidance for Estimating and Controlling Erosion at Culvert Outlets," Miscellaneous Paper H-72-5, U. S. Army Engineer Waterways Experiment Station, CE, Vicksburg, Miss.
34. _____. 1972 (Jun). "Evaluation of Flared Outlet Transitions; Hydraulic Model Investigation," Research Report H-72-1, U. S. Army Engineer Waterways Experiment Station, CE, Vicksburg, Miss.
35. Fletcher, B. P., et al. "Dynamic Loading on Stilling Basin Side-walls" (in preparation), U. S. Army Engineer Waterways Experiment Station, CE, Vicksburg, Miss.
36. Fontane, D. G., et al. 1977 (Apr). "Marysville Lake Hydrothermal Study; 900-MW Project; Hydraulic and Mathematical Investigation," Technical Report H-77-5, Report 1, U. S. Army Engineer Waterways Experiment Station, CE, Vicksburg, Miss.
37. Fortey, J. W., and Tiry, R. F. 1972 (May). "Flow-Induced Vibrations of Trashrack Bars," Civil Engineering, Vol 42, No. 5, pp 44-45.
38. Franke, P. G. 1969 (Feb). "Some Roughness Values of Water Pipelines," L'Energia Elettrica, Vol 46, No. 2, pp 78-80.
39. Freeman, J. R., ed. 1929. Hydraulic Laboratory Practice, American Society of Mechanical Engineers, New York.
40. George, J. F., and Pickering, G. A. 1977 (Apr). "Powerhouse Intake Gate Catapult Study, Big Bend Dam, South Dakota, and Stockton, Harry S. Truman, and Clarence Cannon Dams, Missouri; Hydraulic

15 Oct 80

Model Investigation," Technical Report H-77-8, U. S. Army Engineer Waterways Experiment Station, CE, Vicksburg, Miss.

41. Gibson, A. H. 1914. "The Conversion of Kinetic to Potential Energy in the Flow of Water Through Passages Having Divergent Boundaries," Engineering, Vol 93, p 205.
42. Glorioud, T. L., and Bohan, J. P. 1973 (Sep). "Selective Withdrawal from Beech Fork Lake, Beech Fork River, West Virginia; Hydraulic Model Investigation," Technical Report H-73-14, U. S. Army Engineer Waterways Experiment Station, CE, Vicksburg, Miss.
43. Gordon, J. L. 1970 (Apr). "Vortices at Intakes," Water Power, pp 138-139.
44. Grace, J. L., Jr. 1966 (Feb). "Resistance Coefficients for Structural Plate Corrugated Pipe; Hydraulic Model Investigation," Technical Report No. 2-715, U. S. Army Engineer Waterways Experiment Station, CE, Vicksburg, Miss.
45. _____. 1972 (Jan). "Outlet Works for Branched Oak and Cottonwood Springs Dams, Oak Creek, Nebraska, and Cottonwood Springs Creek, South Dakota; Hydraulic Model Investigation," Technical Report H-72-1, U. S. Army Engineer Waterways Experiment Station, CE, Vicksburg, Miss.
46. Grace, J. L., Jr., and Pickering, G. A. 1971 (Apr). "Evaluation of Three Energy Dissipators for Storm-Drain Outlets; Hydraulic Laboratory Investigation," Research Report H-71-1, U. S. Army Engineer Waterways Experiment Station, CE, Vicksburg, Miss.
47. Griffiths, P. T. A., and Brett, T. M. 1974 (Dec). "A Scouring Rock Trap in Lemonthyme Power Tunnel," Fifth Australasian Conference on Hydraulics and Fluid Mechanics.
48. Hart, E. D., and Tool, A. R. 1976 (Oct). "Sluice Pressures, Gate Vibrations, and Stilling Basin Wall Pressures, Libby Dam, Kootenai River, Montana," Technical Report H-76-17, U. S. Army Engineer Waterways Experiment Station, CE, Vicksburg, Miss.
49. Hoffman, A. 1929. "Losses in 90-Degree Pipe Bends of Constant Circular Cross Section," Transactions, Hydraulic Institute of the Munich Technical University, Bulletin 3; Translation published by American Society of Mechanical Engineers, New York, 1935.

EM 1110-2-1602
15 Oct 80

50. Hu, W. W. 1973 (Nov). "Hydraulic Elements for the USBR Standard Horseshoe Tunnel," Journal, Transportation Engineering, American Society of Civil Engineers, Vol 99, No. TE4, pp 973-984.
51. Huang, T. T. 1964. Energy Losses in Pipe Expansions, M.S. Thesis, University of Iowa, Iowa City, Iowa.
52. Huval, C. J. 1969 (Jul). "Hydraulic Design of Unlined Rock Tunnels," Journal, Hydraulics Division, American Society of Civil Engineers, Vol 95, No. HY4, Proc Paper 6679, pp 1235-1246.
53. Johnson, P. L. 1971 (Sep). "Hydraulic Model Studies of the Reservoir Inlet-Outlet Structure for Horse Mesa Pump-Storage Unit, Salt River Project, Arizona," Report REC-ERC-71-34, Bureau of Reclamation, Denver, Colo.
54. Jones, H. W. 1977 (Jun). "Manual for a Conversationally Oriented Real-Time Program-Generating System (CORPS)," Unnumbered Report, U. S. Army Engineer Waterways Experiment Station, CE, Vicksburg, Miss.
55. Kalinske, A. A., and Robertson, J. M. 1943. "Entrainment of Air in Flowing Water-Closed Conduit Flow," Transactions, American Society of Civil Engineers, Vol 108, pp 1435-1447.
56. King, H. W., and Brater, E. F. 1963. Handbook of Hydraulics for the Solution of Hydrostatic and Fluid-Flow Problems, 5th ed., McGraw-Hill, New York.
57. Knapp, R. T., Daily, J. W., and Hammitt, F. G. 1970. Cavitation, McGraw-Hill, New York.
58. Lancaster, D. M., and Dexter, R. B. 1959 (Nov). "Hydraulic Characteristics of Hollow-Jet Valves," Journal, Hydraulics Division, American Society of Civil Engineers, Vol 85, No. HY11, p 53.
59. Levin, L. 1973 (Jan). "Study of Peculiar Head Losses in Conical Convergences," Translation No. 73-3, U. S. Army Engineer Waterways Experiment Station, CE, Vicksburg, Miss.
60. Locher, F. A. 1969 (Feb). "Some Aspects of Flow-Induced Vibrations of Hydraulic Control Gates," Contract Report H-69-1, U. S. Army Engineer Waterways Experiment Station, CE, Vicksburg, Miss.

15 Oct 80

61. Loftis, B., and Fontane, D. C. 1976 (Apr). "Falls Lake Water-Quality Study; Hydraulic Laboratory Investigation," Miscellaneous Paper H-76-6, U. S. Army Engineer Waterways Experiment Station, CE, Vicksburg, Miss.
62. Loftis, B., Saunders, P. E., and Grace, J. L., Jr. 1976 (Feb). "B. Everett Jordan Lake Water-Quality Study," Technical Report H-76-3, U. S. Army Engineer Waterways Experiment Station, CE, Vicksburg, Miss.
63. Louis, D. S., and Allen, A. E. 1971 (Jan). "Trash Rack Studies - Seneca Pumped-Storage Plant," Meeting Preprint 1284, National Water Resources Engineering Meeting, American Society of Civil Engineers, Phoenix, Ariz., 11-15 Jan 1971.
64. Madison, R. D., and Parker, J. R. 1936. "Pressure Losses in Rectangular Elbows," Transactions, American Society of Mechanical Engineers, Vol 58, pp 167-176.
65. Marchetti, M., and Nosedá, G. 1960 (Apr). "Head Losses in Symmetrical Penstock Bifurcations with a Constant Diameter," L'Energia Elettrica, Vol XXXII, No. 4; also published as Translation No. 63-2, Aug 1963, U. S. Army Engineer Waterways Experiment Station, CE, Vicksburg, Miss.
66. Mattimoe, J. J., Tinney, E. R., and Wolcott, W. W. 1965 (Oct). "Rock Trap Experience in Unlined Tunnels," Journal, Power Division, American Society of Civil Engineers, Vol 90, No. P03, Paper 4067, pp 29-45.
67. Maynard, S. T., Loftis, B., and Fontane, D. G. 1978 (Jan). "Temperature Analysis and Selective-Withdrawal Design Study, Tallahala Creek Lake, Mississippi; Mathematical Model Investigation," Technical Report H-78-1, U. S. Army Engineer Waterways Experiment Station, CE, Vicksburg, Miss.
68. Melsheimer, E. S. 1969 (Dec). "Outlet Works for Beltzville Dam, Pohopoco Creek, Pennsylvania; Hydraulic Model Investigation," Technical Report H-69-18, U. S. Army Engineer Waterways Experiment Station, CE, Vicksburg, Miss.
69. _____. 1973 (Jun). "Outlet Works Stilling Basins, Clinton and Fort Scott Dams, Wakarusa and Marmaton Rivers, Kansas; Hydraulic Model Investigation," Technical Report H-73-6, U. S. Army Engineer Waterways Experiment Station, CE, Vicksburg, Miss.

EM 1110-2-1602

15 Oct 80

70. Melsheimer, E. S., and Oswalt, N. R. 1969 (Oct). "Outlet Works for New Hope Reservoir, Cape Fear River Basin, North Carolina; Hydraulic Model Investigation," Technical Report H-69-14, U. S. Army Engineer Waterways Experiment Station, CE, Vicksburg, Miss.
71. Mercer, A. C. 1970. "Vane Failures of Hollow-Cone Valves," Proceedings, IAHR, Stockholm, Sweden.
72. Miller, D. S. 1971. "Internal Flow; A Guide to Losses in Pipes and Duct Systems," British Hydromechanics Research Association, England.
73. Moody, L. F. 1944. "Friction Factors for Pipe Flow," Transactions, American Society of Mechanical Engineers, Vol 66, pp 671-684.
74. Moore, M. O. 1968 (Oct). "Incrustation in Water Pipelines," Journal, Pipeline Division, American Society of Civil Engineers, Vol 94, No. P11, Paper 6161, pp 37-47.
75. Munsey, T. E., and Neilson, F. M. 1971 (Apr). "Prototype Observations of Snettisham Project Diversion Tunnel, Long Lake, Alaska," Miscellaneous Paper H-71-7, U. S. Army Engineer Waterways Experiment Station, CE, Vicksburg, Miss.
76. Murphy, T. E. 1959 (Jun). "Entrances to Conduits of Rectangular Cross Section; Investigation of Entrances Flared in Three Directions and in One Direction," Technical Memorandum No. 2-428, Report 2, U. S. Army Engineer Waterways Experiment Station, CE, Vicksburg, Miss.
77. _____. 1971 (Mar). "Control of Scour at Hydraulic Structures," Miscellaneous Paper H-71-5, U. S. Army Engineer Waterways Experiment Station, CE, Vicksburg, Miss.
78. Nag, P. K. 1970 (Aug). "Free Discharge Regulating Valves; Their Characteristics, Uses, and Limitations," Control of Flow in Closed Conduits, Proceedings of the Institute, held at Colorado State University, Ft. Collins, Colo., 9-14 Aug 1970, pp 451-470.
79. Naudascher, E., Kobus, H. E., and Rao, Ragem Pondu R. 1964 (May). "Hydrodynamics Analysis for High-Head Leaf Gates," Journal, Hydraulics Division, American Society of Civil Engineers, Vol 99, No. HY3, Proc Paper 3904, pp 155-192.

15 Oct 80

80. Neilson, F. M. 1971 (Sep). "Howell-Bunger Valve Vibration, Summersville Dam, Prototype Tests," Technical Report H-71-6, U. S. Army Engineer Waterways Experiment Station, CE, Vicksburg, Miss.
81. Neilson, F. M., and Carstens, M. R. 1967 (Jul). "Hydraulic Model Studies of Pahlau Dam Sluiceways," Industrial Research Project A-962, Georgia Institute of Technology, Atlanta, Ga.
82. Nikuradse, J. 1932. "Gesetzmässigkeiten der Turbulenten Stromung in Glatten Rohren" (in German), VDI Forschungsheft 356.
83. Office, Chief of Engineers. 1970. "Alternate Conduit Gate Control Structure," ETL 1110-2-84, 13 Mar 1970, Washington, D. C.
84. _____. 1971. "Additional Guidance for Riprap Channel Protection" (Change 1), ETL 1110-2-120, 14 May 1971, Washington, D. C.
85. _____. 1974. "Stilling Basins for Reservoir Outlet Works," ETL 1110-2-193, 30 Aug 1974, U. S. Army Engineer Waterways Experiment Station, CE, Vicksburg, Miss.
86. _____. 1978. "Nitrogen Supersaturation," ETL 1110-2-239, 15 Sep 1978, Washington, D. C.
87. Ortoano, L. 1974 (Jan). "Issues in Water Resources Impact Assessments," Journal, Hydraulics Division, American Society of Civil Engineering, Vol 100, No. HYL, Proc Paper 10292, pp 173-187.
88. Oswalt, N. R. 1971 (Mar). "Pomona Dam Outlet Stilling Basin Modifications," Memorandum Report, U. S. Army Engineer Waterways Experiment Station, CE, Vicksburg, Miss.
89. _____. 1973 (Apr). "Outlet Works Stilling Basin for Tallahala Dam, Tallahala Creek, Mississippi; Hydraulic Model Investigation," Technical Report H-73-5, U. S. Army Engineer Waterways Experiment Station, CE, Vicksburg, Miss.
90. Parmakian, J. 1955. Waterhammer Analysis, 1st ed., Chapter 3, Prentice-Hall, New York.
91. Petermann, F. 1929. "Loss in Oblique-Angled Pipe Branches," Transactions, Hydraulic Institute, Technical University, Munich, Bulletin 3; published by ASEM, Bulletin 3, 1935.

15 Oct 80

92. Peters, H. 1934 (Mar). "Conversion of Energy in Cross-Sectional Divergencies Under Different Conditions of Inflow" (translation), Technical Memorandum No. 737, National Advisory Committee for Aeronautics, Washington, D. C.
93. Pickett, E. B., Hart, E. D., and Neilson, F. M. 1970 (Aug). "Prototype Experiments with Large Gates and Valves," Control of Flow in Closed Conduits, Proceedings of the Institute, held at Colorado State University, Ft. Collins, Colo., 9-14 Aug 1970, pp 495-518.
94. Prandtl, L. 1932. "Zur Turbulenten Stromung in Rohren und Langs Platten" (in German), Ergebnisse der Aerodynamischen Versuchsanstalt zu Gottinhen, IV Lieferung, R. Oldenberg, Munich and Berlin, pp 18-21.
95. Reddy, Y. R., and Pickford, J. A. 1972 (Mar). "Vortices at Intakes in Conventional Sumps," Water Power, pp 108-109.
96. "Report to the Vice-President and to the President's Council on Recreation and Natural Beauty," 1 Nov 1968, Working Committee on Federal Construction, Washington, D. C.
97. Ripken, J. F. 1970 (Aug). "Fundamentals of Cavitation," Control of Flow in Closed Conduits, Proceedings of the Institute, held at Colorado State University, Ft. Collins, Colo., 9-14 Aug 1970, pp 353-378.
98. Robertson, R. A., and Ball, J. W. 1971 (Jul). "Model Study of Power Intake Gate of Mossyrock Dam," Journal, Hydraulics Division, American Society of Civil Engineers, Vol 97, No. HY7, Proc Paper 8229, pp 889-906.
99. Rouse, H. 1946. Elementary Mechanics of Fluids, Wiley, New York.
100. _____. 1946. "Use of the Low-Velocity Air Tunnel in Hydraulic Research," Proceedings, Third Hydraulics Conference, State University of Iowa.
101. _____. 1950. Engineering Hydraulics, Wiley, New York.
102. Rouse, H., Bhoote, B. V., and Hsu, En-Yun. 1951. "Design of Channel Expansions," Transactions, American Society of Civil Engineers, Vol 116.

103. Rueda-Briceno, D. 1954 (Feb). "Pressure Conditions at the Outlet of a Pipe," M.S. Thesis, University of Iowa, Iowa City, Iowa.
104. Russell, S. O., and Bell, J. W. "Sudden Enlargement Energy Dissipators for Mica Dam Outlets," Western Canada Hydraulic Laboratories, Ltd., Port Coquitlam, B. C., Canada.
105. Ruus, E. 1970 (Mar). "Head Losses in Wyes and Manifolds," Journal, Hydraulics Division, American Society of Civil Engineers, Vol 96, No. HY3, Proc Paper 7130, pp 593-608.
106. Schlichting, H. 1968. Boundary-Layer Theory, 6th ed., McGraw-Hill, New York; translated by Dr. J. Kestin, Brown University, Providence, R. I.
107. Schoder, E. W., and Dawson, F. M. 1934. Hydraulics, 2d ed., McGraw-Hill, New York.
108. Schoklitsch, A. 1937. Hydraulic Structures; A Text and Handbook, Vol II, American Society of Mechanical Engineers, New York.
109. Scott, L. R., Jr. 1970 (Dec). "Scott's Plots for Compressible Flow Through Duct System Elements," NASA Technical Brief No. 70-10487.
110. Sell, L. E. 1971 (Jan). "Hydroelectric Power Plant Trashrack Design," Journal, Power Division, American Society of Civil Engineers, Vol 97, No. P01, Paper 7819, pp 115-121.
111. Sharma, H. R. 1976 (Nov). "Air-Entrainment in High Head Gated Conduits," Journal, Hydraulics Division, American Society of Civil Engineers, Vol 102, No. HY11, Proc Paper 12523, pp 1629-1646.
112. Silberman, E., and Dahlin, W. Q. 1971 (Apr). "Further Studies of Friction Factors for Corrugated Aluminum Pipes Flowing Full," Project Report No. 121, St. Anthony Falls Hydraulic Laboratory, University of Minnesota, Minn.
113. Simmons, W. P., Jr. 1959 (Jan). "Air Model Studies of Hydraulic Downpull on Large Gates," Journal, Hydraulics Division, American Society of Civil Engineers, Vol 85, No. HY1, Paper No. 1903.
114. Singh, A. 1969 (May). "Transition from Circular to Rectangular Section," Journal, Hydraulics Division, American Society of Civil Engineers, Vol 95, No. HY3, Proc Paper 6562, pp 893-906.

EM 1110-2-1602
15 Oct 80

115. Smith, P. M. 1964 (May). "Hydraulic Downpull on Ice Harbor Powerhouse Gate," Journal, Hydraulics Division, American Society of Civil Engineers, Vol 90, No. HY3, Proc Paper 3903, pp 193-213.
116. Sprenger, H. 1969 (Mar). "Head Losses in 90° Elbows for Rectangular Pipes," Schweizerische Bauzeitung, Vol 87, No. 13, pp 223-231; also published as Translation No. 70-3, Sep 1970, U. S. Army Engineer Waterways Experiment Station, CE, Vicksburg, Miss.
117. Straub, L. G., and Morris, H. M. 1950. "Hydraulic Tests on Corrugated Metal Culvert Pipes," Technical Paper No. 5, Series B, St. Anthony Falls Hydraulic Laboratory, University of Minnesota, Minn.
118. Streeter, V. L. 1961. Handbook of Fluid Dynamics, McGraw-Hill, New York.
119. Syamala Rao, B., Lakshmana Rao, N. S., and Shivaswamy, M. S. 1968 (Nov). "Energy Losses at Conduit Trifurcations," Journal, Hydraulics Division, American Society of Civil Engineers, Vol 94, No. HY6, Proc Paper 6207, pp 1363-1374.
120. Thomas, C. W. 1955 (Jul). "Discharge Coefficients for Gates and Valves," Proceedings, American Society of Civil Engineers, Paper No. 746.
121. Thompson, W. T. 1965. Vibration Theory and Applications, Prentice-Hall, Englewood Cliffs, N. J.
122. U. S. Army Engineer Institute for Water Resources, CE. 1972 (Jun). "An Analysis of Environmental Statements for Corps of Engineers Water Projects," IWR Report 72-3, Ft. Belvoir, Va.
123. U. S. Army Engineer Waterways Experiment Station, CE. 1947 (Jun). "Model Studies of Conduits and Stilling Basin, Bull Shoals Dam, White River, Arkansas," Technical Memorandum No. 2-234, Vicksburg, Miss.
124. _____. 1952 (Jun). "Outlet Works Stilling Basin for Texarkana Dam, Sulphur River, Texas; Hydraulic Model Investigation," Technical Memorandum No. 2-346, Vicksburg, Miss.
125. _____. 1953 (Apr). "Pressure and Air Demand Tests in

15 Oct 80

- Flood-Control Conduit, Denison Dam, Red River, Oklahoma and Texas," Miscellaneous Paper No. 2-31, Vicksburg, Miss.
126. U. S. Army Engineer Waterways Experiment Station, CE. 1954 (Dec). "Flood Control Outlet Structures for Tuttle Creek Dam, Big Blue River, Kansas; Hydraulic Model Investigation," Technical Memorandum No. 2-396, Vicksburg, Miss.
 127. _____. 1956 (Mar). "Cavitation at Baffle Piers; CWI Item No. 806, Cavitation Investigation (Hydraulics)," Miscellaneous Paper No. 2-154, Vicksburg, Miss.
 128. _____. 1956 (Mar). "Entrances to Conduits of Rectangular Cross Section; Investigation of Entrance Flared in Four Directions, CWI Item No. 802, Conduit Intake Model Tests," Technical Memorandum No. 2-428, Report No. 1, Vicksburg, Miss.
 129. _____. 1956 (Mar). "The Effect of Artificial Stimulation of the Turbulent Boundary Layer in Rectangular Conduits," Miscellaneous Paper No. 2-160, Vicksburg, Miss.
 130. _____. 1959 (Jun). "Outlet Works for Abiquiu Dam, Rio Chama, New Mexico; Hydraulic Model Investigation," Technical Report No. 2-513, Vicksburg, Miss.
 131. _____. 1959 (Jun). "Prototype Tests in Flood-Control Conduit, Enid Dam, Yocona River, Mississippi," Technical Report No. 2-510, Vicksburg, Miss.
 132. _____. 1960 (Sep). "Outlet Works for Oahe Dam, Missouri River, South Dakota; Hydraulic Model Investigation," Technical Report No. 2-557, Vicksburg, Miss.
 133. _____. 1963 (Mar). "Impact-Type Energy Dissipator for Storm-Drainage Outfalls, Stilling Well Design; Hydraulic Model Investigation," Technical Report No. 2-620, Vicksburg, Miss.
 134. _____. "Tuttle Creek Prototype Tests" (unpublished), Vicksburg, Miss.
 135. U. S. Bureau of Reclamation. 1938. "Model Studies of Penstocks and Outlet Works; Boulder Canyon Project, Final Report, Part VI--Hydraulic Investigations," Bulletin 2, Denver, Colo.
 136. _____. 1958 (Jul). "Importance of Smooth Surfaces on Flow

15 Oct 80

Boundaries Downstream from Outlet Works Control Gates," Hydraulic Laboratory Report No. HYD-448, Denver, Colo.

137. U. S. Bureau of Reclamation. 1958 (Sep). "Hydraulic Design of Stilling Basin and Energy Dissipators," Engineering Monograph No. 25 (Revised Jul 1963), Denver, Colo.
138. _____. 1963 (Jan). "Hydraulic Model Study of the Diversion Tunnels for Oroville Dam, California," Department of Water Resources, Hydraulic Branch Report No. HYD-502, Denver, Colo.
139. _____. 1969 (Jun). "Progress Report No. XIII, Research Study on Stilling Basin Energy Dissipators and Associated Appurtenances - Section 14, Modification of Section 6 (Stilling Basin for Open Channel Outlets - Basin VI)," Report No. HYD-572, Denver, Colo.
140. _____. 1971 (Feb). "Hydraulic Model Studies of Folsom Spillway-Outlet Junction," REC-ERC-71-12, Denver, Colo.
141. Vogel, G. 1926 and 1928. "Investigation of Loss in Right-Angled Pipe Branches," Hochschule-Munchen No. 1, 1926, and No. 2, 1928, Hydraulic Institute, Technical University.
142. Von Karman, T. 1930. "Mechanische Aehnlichkeit und Turbulenz" (in German), Proceedings, Third International Congress for Applied Mechanics, Stockholm, Vol 1, pp 85-93; A graph labels the smooth pipe curve "Von Karman-Prandtl, 1921."
143. Wang, T. S. 1972 (Jun). Turbulent Flow in a Pipe Inlet Region, Ph. D. Dissertation, Colorado State University, Ft. Collins, Colo.
144. Wasielewski, R. 1932. "Loss in Smooth Pipe Bends with Bend Angles Less Than 90°" (in German), Mitteilungen des Hydraulischen Instituts der Technischen Hochschulen Muenchen, Munich, Heft 5, pp 53-67.
145. Williamson, J. V., and Rhone, T. J. 1973 (May). "Dividing Flow in Branches and Wyes," Journal, Hydraulics Division, American Society of Civil Engineers, Vol 99, No. HY5, Proc Paper 9729, pp 747-769.
146. Yarnell, D. L. 1937 (Oct). "Flow of Water Through 6-Inch Pipe Bends," Technical Bulletin No. 577, U. S. Department of Agriculture, Washington, D. C.
147. Zanker, K. J., and Brock, T. E. 1967 (Jul). "A Review of the Literature on Fluid Flow Through Closed Conduit Bends," TH 901, British Hydromechanics Research Association.

APPENDIX B

NOTATION

Symbol	Term	Units
a	Length of miter bend segment	ft
A	Cross-sectional area (subscripts denote locations)	ft ²
B	Width (in breadth)	ft
c	Distance in fillet detail	ft
C	Circular shape	--
	Discharge coefficient	--
	Pressure drop coefficient (subscripts denote dimension of flow)	--
	Celerity (velocity) of pressure wave	ft/sec
	Resistance coefficient in Chezy's equation	ft ^{1/2} /sec
	Relative loss coefficient	--
	Half width of conduit	ft
	Critical-slope surface profile (subscripts denote relation to depth)	--
C _c	Contraction coefficient	--
* C _k	Conveyance factor (1.486 AR ^{2/3})	ft ^{19/6} /sec *
* C _m	Coefficient for modified center-line trajectory for stilling basins subject to low-flow eddies	-- *
C _p	Pressure drop parameter	--
CORPS	<u>C</u> onversationally <u>O</u> riented <u>R</u> eal-Time <u>P</u> rogram-Generating <u>S</u> ystem	--
d	Diameter	ft
	Depth of flow	ft
d ₁	Depth of flow entering hydraulic jump	ft

(Continued)

(Sheet 1 of 8)

EM 1110-2-1602
 Change 1
 15 Mar 87

NOTATION

Symbol	Term	Units
d_2	Depth of flow leaving hydraulic jump	ft
dy/dx	Differential of y with respect to x	ft/ft
D	Diameter or height of conduit (subscripts denote locations)	ft
	Dimension of conduit in plane of entrance curve	ft
	Valve diameter	ft
	Depth of gate slot	ft
D_h	Equivalent hydraulic diameter ($=4 \times$ hydraulic radius)	ft
D_{50}	Median diameter of riprap stone (by weight)	ft
e	Half of transition wall conveyance	ft
E	Modulus of elasticity	lb/ft ²
	Gate passage invert elevation	ft msl
EGL	Energy grade line	--
f	Resistance coefficient (factor) in Darcy-Weisbach formula	--
f_f	Forcing frequency	H_z
f_n	Natural frequency	H_z
F	Froude number	--
g	Gravitational acceleration	ft/sec ²
G_o	Gate opening	ft
h_b	Bend loss	ft
h_e	Entrance (intake) loss	ft

(Continued)

(Sheet 2 of 8)

NOTATION

<u>Symbol</u>	<u>Term</u>	<u>Units</u>
h_f	Head loss due to surface resistance (friction)	ft
h_l	Head loss due to form	ft
h_o	Pressure head in undisturbed flow	ft
h_v	Velocity head	ft
	Vapor pressure	ft
H	Total energy head	ft
	Horseshoe shape	--
	Height of conduit or wall	ft
	Piezometric head	ft
	Horizontal	--
	Horizontal channel surface profile (subscripts denote relation to depth)	--
H_d	Pressure drop	ft
H_D	Pressure drop	ft
H_e	Energy head	ft
H_i	Minimum piezometric head	ft
H_L	Total head loss (subscripts denote locations)	ft
H_v	Velocity head	ft
k	Roughness height	ft
K	Loss coefficient (subscripts denote type)	--
l	Length of cable	ft
L	Length of conduit	ft
	Distance along conduit	ft

(Continued)

(Sheet 3 of 8)

NOTATION

Symbol	Term	Units
L_B	Length of basic	ft
L_e	Equivalent conduit length	ft
L_f	Length of fillet	ft
L_p	Plate width	ft
L_t	Length of tangent	ft
L_T	Length of transition	ft
LN	Natural logarithm (base e)	--
M	Mild-slope surface profile (subscripts denote relation to depth)	--
	Momentum	ft ³
	Model data	--
n	Resistance coefficient in Manning's formula	ft ^{1/6}
O	Oblong shape	--
p	Pressure (subscripts denote locations)	lb/ft ²
p_v	Vapor pressure	lb/ft ²
P	Wetted perimeter	ft
	Offset distance	ft
	Prototype data	--
	Number of gate passages	--
PC	Point of curvature	--
PI	Point of intersection of tangents	--
PT	Point of tangency	--

(Continued)

(Sheet 4 of 8)

15 Oct 80

NOTATION

Symbol	Term	Units
PCC	Point of compound curvature	--
PGL	Piezometric grade line	--
PRC	Point of reverse curvature	--
Q	Discharge	ft ³ /sec
Q _a	Air demand	ft ³ /sec
Q _w	Water discharge	ft ³ /sec
r	Curve radius (subscripts denote locations)	ft
r _a	Arc radius	ft
r _f	Fillet radius	ft
R	Hydraulic radius	ft
	Rectangular shape	--
	Curve radius (subscripts denote locations)	ft
	Radial offset distance	ft
IR	Reynolds number, $IR = VD/\nu$	--
S	Average loss of head per unit of length (energy gradient slope)	ft/ft
	Steep-slope surface profile (subscripts denote relation to depth)	--
	Submergence	ft
	Conduit invert slope	ft/ft
S _f	Friction slope	ft/ft
S _t	Strouhal number	--

(Continued)

(Sheet 5 of 8)

EM 1110-2-1602

15 Oct 80

NOTATION

Symbol	Term	Units
S_{cn}	Critical slope for normal depth	ft/ft
t	Gate leaf thickness	ft
t_h	Local transition half height	ft
t_w	Local transition half width	ft
T	Temperature	°F
	Width of water surface	ft
V	Average (mean) velocity (subscripts denote locations)	ft/sec
	Vertical	--
V_{sm}	Average (mean) velocity for smooth pipe flow	ft/sec
W	Conduit width	ft
	Gate slot width	ft
W_b	Width of basin	ft
W_s	Local width of basin on sloping apron	ft
W_{50}	Median weight of riprap stone	lb
x	Vibration amplitude	ft
	Horizontal or longitudinal coordinate or distance	ft
x_0	Zero frequency deflection	ft
X	Horizontal or longitudinal coordinate or distance (subscripts denote locations)	ft
y	Vertical or transverse coordinate or distance	ft
	Depth of flow (subscripts denote locations)	ft

(Continued)

(Sheet 6 of 8)

NOTATION

Symbol	Term	Units
y_c	Critical depth	ft
y_o	Normal depth	ft
y_p	Height of pressure grade line at exit portal	ft
\bar{y}	Average piezometric pressure	ft
* y'	Vertical coordinate	ft *
Y	Vertical or transverse coordinate or distance	ft
	Projection of gate into conduit	ft
Z	Elevation above datum plane (subscripts denote locations)	ft
	Section factor	ft ^{5/2}
α	Kinetic energy correction factor (subscripts denote locations)	—
β	Angular distance to location of H_1	deg
	Gate lip angle	deg
γ	Specific (unit) weight	lb/ft ³
ΔA	Change in area	ft ²
ΔB	Increment of width	ft
ΔL	Flare ratio of stilling basin sidewall	ft/ft
	Length of reach between two sections	ft
ΔP	Pressure difference	ft
n	Depth ratio (y/y_o)	ft/ft

(Continued)

(Sheet 7 of 8)

EM 1110-2-1602
 Change 1
 15 Mar 87

NOTATION

Symbol	Term	Units
θ	Conduit invert slope	deg
	Boundary contraction or expansion angle	deg
	Angular displacement or deflection	deg
θ_p	Slope of tangent extension from pier	deg
ν	Kinematic viscosity	ft ² /sec
π	3.14159	--
σ	Root-mean-square of random roughness height	ft
	Unit stress in cable	lb/ft ²
	Interfacial surface tension	lb/ft
σ	Cavitation number or index	--
σ_i	Incipient cavitation number	--
ϕ	Flare angle of stilling basin sidewall	deg
\underline{c}	Center line	--
$^{\circ}\text{F}$	Fahrenheit temperature	deg
$>$	Greater than	--
$<$	Less than	--

(Sheet 8 of 8)

15 Oct 80

APPENDIX C

PLATES

<u>Plate No.</u>	<u>Title</u>	<u>Paragraphs in Which Plate Is Mentioned</u>
C-1	Open-Channel Flow Classifications	2-3,4-16
C-2	Pressure Flow Definition Sketch	2-6,2-9,3-7
C-3	Exit Portal Pressure	2-7,5-2d(2),Table D-4, F-3e(1)
C-4	Resistance Coefficients, Concrete Conduits	2-12a,c,d,e,g,g(1)(b), g(1)(c),g(2)(b),5-2c, Table D-4
C-5	Hydraulic Elements, Conduit Sections	2-12f,4-2c
C-6	Flow Characteristics, Horseshoe Conduits	2-12f
C-7	Resistance Coefficient, Corrugated Metal Pipe	2-12g(3)
C-8	Head Loss Coefficients, Abrupt Transitions	2-13b,c
C-9	Loss Coefficients, Conical Transitions	2-13d
C-10	Bend Loss Coefficients, Circular Conduits	2-13e(2)(a)
C-11	Loss Coefficients, Circular Con- duits, Multiple Miter Bends	2-13e(2)(a)
C-12	Loss Coefficients, Rectangular Con- duits, 90° Circular Bends	2-13e(2)(b)
C-13	Relative Loss Coefficients, Rectan- gular Conduits, Circular Bends	2-13e(2)(b)
C-14	Loss Coefficients, Rectangular Con- duits, Triple Bend	2-13e(2)(b)
C-15	Examples of Cavitation Hydraulics	2-14
C-16	Air Demand, Primary and Secondary Maxima	2-19
C-17	Air Demand	2-19

EM 1110-2-1602
15 Oct 80

<u>Plate No.</u>	<u>Title</u>	<u>Paragraphs in Which Plate Is Mentioned</u>
C-18	Sluice Location, Monolith Center Line	3-1,3-3a
C-19	Typical Off-Monolith Center Line Sluice Location	3-1
C-20	Conduits, Circular Bends, Minimum Pressure	3-3b
C-21	Sluice Intakes	3-4,4-21
C-22	Pressure Drop Coefficients, Sluice Entrances	3-6c,4-12,4-21
C-23	Vertical-Lift Gate, Gate Slot Details	3-9a,3-13,3-17f,4-15, 4-16
C-24	Discharge Coefficients, Conduit Tainter Gates, Free Flow	3-9b
C-25	Discharge Coefficients, Fixed-Cone Valves	3-10d
C-26	Pressure Coefficients, Gate Slot	3-13
C-27	Incipient Cavitation Coefficients for Slots	3-13
C-28	Sluice Exit Portal, Roof Constrictions	3-19
C-29	Exit Portal Deflector, Allegheny Dam Model	3-19
C-30	Sluice Exit Portal, Sidewall Flare with Roof Constriction, Red Rock Dam Model	3-19
C-31	Sluice Eyebrow Deflector, Folsom Dam Model	3-20
C-32	Intake Loss Coefficients, All Gates Fully Open	4-3a,4-21,D-8,Table D-4
C-33	Intake Loss Coefficients, All or Fewer Gates Open	4-3a,4-21
C-34	Concrete Conduits, Intake Losses, Drop Inlets	4-3a
C-35	Vortex Formation	4-3c

<u>Plate No.</u>	<u>Title</u>	<u>Paragraphs in Which Plate Is Mentioned</u>
C-36	Types of Conduit Gates	4-9,4-14
C-37	Pressure Drop Coefficients, Entrance with Roof Curve Only	4-12,4-21
C-38	Conduit Entrances with Roof Curve and Side Flare	4-13,4-21
C-39	Discharge Coefficients, Vertical- Lift Gate	4-16
C-40	Definition Sketch, Low-Level Outlets	5-2b
C-41	Stilling Basin Layout, Single Outlet	5-2d(1),5-2h,5-2i
* C-41A	Stilling Basin Trajectory Modifi- cation to Reduce Low Flow Eddies	5-2d(3)
C-42	Outlet Channel	5-2k,5-6
C-43	Preformed Scour Hole	5-4
C-44	Water Quality Intake Types	6-1
C-45	Water Quality Outlet, Concrete Gravity Dam, Rowlesburg Dam	6-2b(4),6-4a
C-46	Water Quality Outlet, Earth Dam, Beltzville	6-2b(4),6-4b
C-47	Intake Structure, Multilevel Detail, Taylorsville Dam	6-2b(4),6-4b
C-48	Intake Structure, Multilevel Detail, New Hope Dam	6-2b(4),6-4b
C-49	Temperature Control Weirs	6-2b(5)
C-50	Multiple Penstock Intake Struc- ture, Dickey Dam	6-4a
C-51	Cylindrical Gate Intake Tower, DeGray Dam	6-4b
C-52	Water Quality Intake, Earth Dam, Beech Fork	6-4b

15 Oct 80

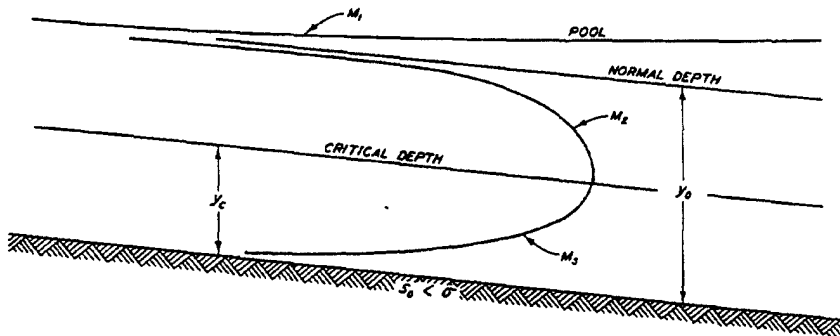

- M₁ - BACKWATER FROM RESERVOIR - UNIFORM CHANNEL.
 $y > y_0, \eta > 1.$
- M₂ - DRAWDOWN TO SPILLWAY WITH SHALLOW APPROACH.
 $y_0 > y > y_c, \eta < 1.$
- M₃ - FLOW UNDER GATE ON MILD SLOPE.
 $y < y_c, \eta < 1.$

MILD SLOPE

$y_0 > y_c$

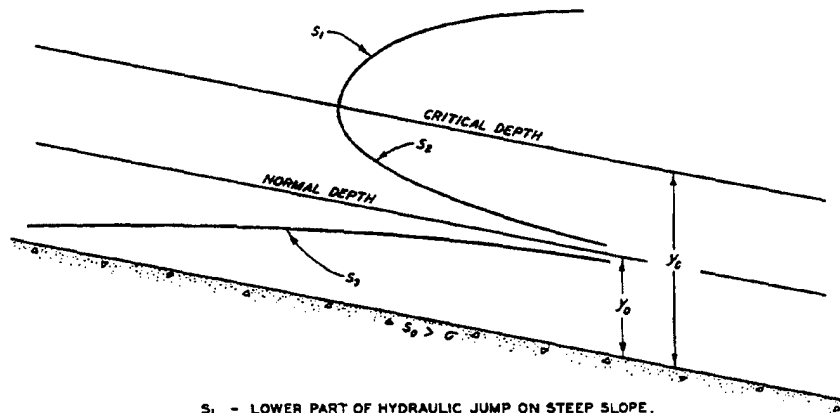

- S₁ - LOWER PART OF HYDRAULIC JUMP ON STEEP SLOPE.
 $y > y_c, \eta > 1.$
- S₂ - CHUTE FLOW FROM LOW OGEE CREST.
 $y_c > y > y_0, \eta > 1.$
- S₃ - CHUTE FLOW FROM HIGH OGEE CREST. FLOW UNDER GATE ON STEEP SLOPE.
 $y < y_0, \eta < 1.$

STEEP SLOPE

$y_0 < y_c$

$\eta = \frac{y}{y_0}$

OPEN-CHANNEL FLOW CLASSIFICATIONS

FROM HDC 010-1

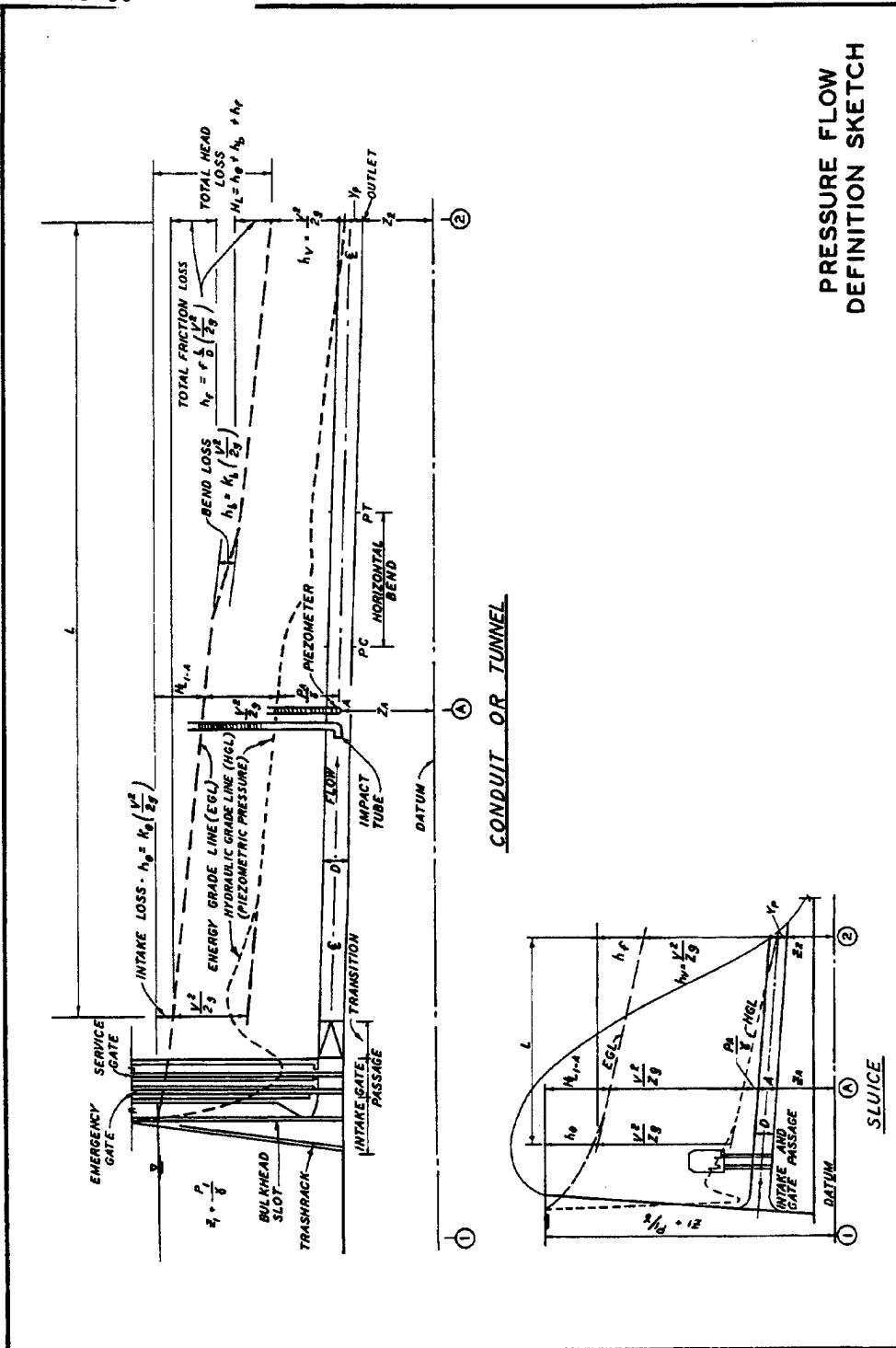
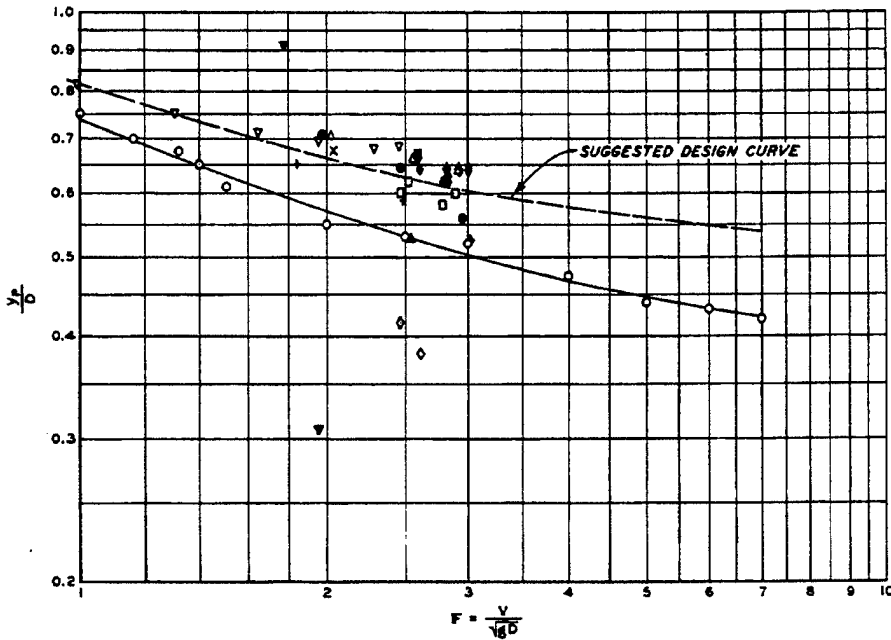

PLATE C-2

PRESSURE FLOW
DEFINITION SKETCH



LEGEND

<u>SYMBOL</u>	<u>DATA SOURCE</u>	<u>BOTTOM SUPPORT</u>	<u>CONDUIT SHAPE</u>
○	STATE UNIVERSITY OF IOWA	NONE	CIRCULAR
□	DENISON MODEL	LEVEL	CIRCULAR
■	DENISON PROTOTYPE	LEVEL	CIRCULAR
●	GARRISON MODEL	PARABOLIC	CIRCULAR
▽	YOUGHIOGHENY MODEL	1 ON 20	CIRCULAR
x	ENID PROTOTYPE	PARABOLIC	CIRCULAR
△	FORT RANDALL MODEL	LEVEL	CIRCULAR
▲	FORT RANDALL PROTOTYPE	LEVEL	CIRCULAR
†	GAHE PROTOTYPE	PARABOLIC	CIRCULAR
◆	BELTZVILLE	PARABOLIC	CIRCULAR
▼	TUTTLE CREEK PROTOTYPE	PARABOLIC	HORSESHOE
◇	MELVERN PROTOTYPE	PARABOLIC	HORSESHOE

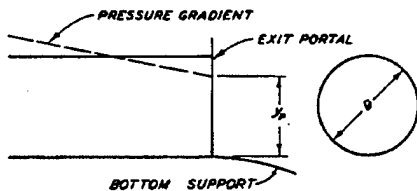

EXIT PORTAL PRESSURE

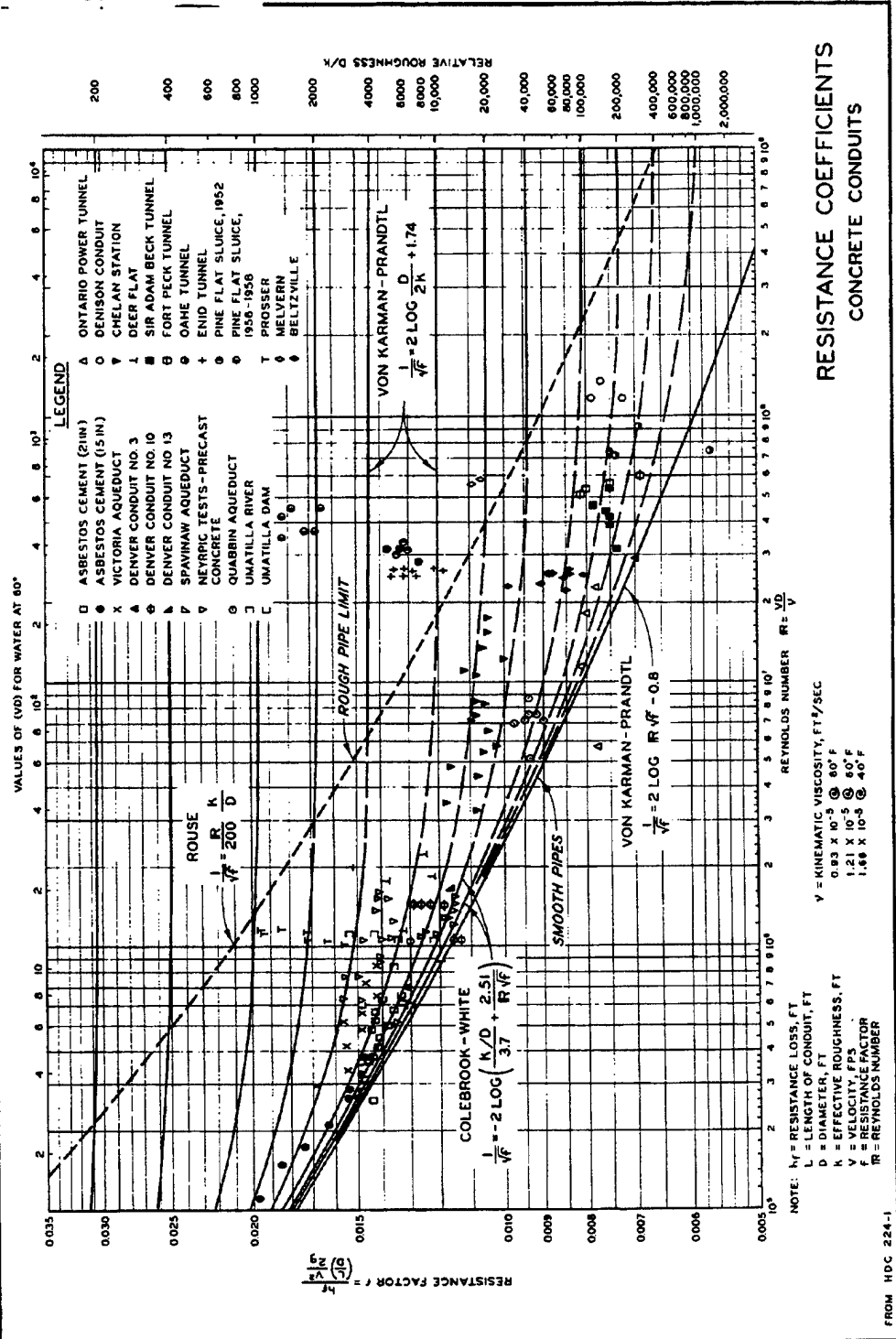
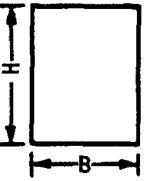
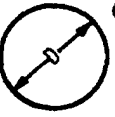
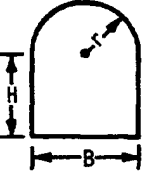
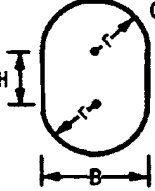
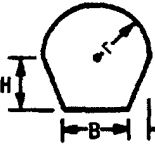

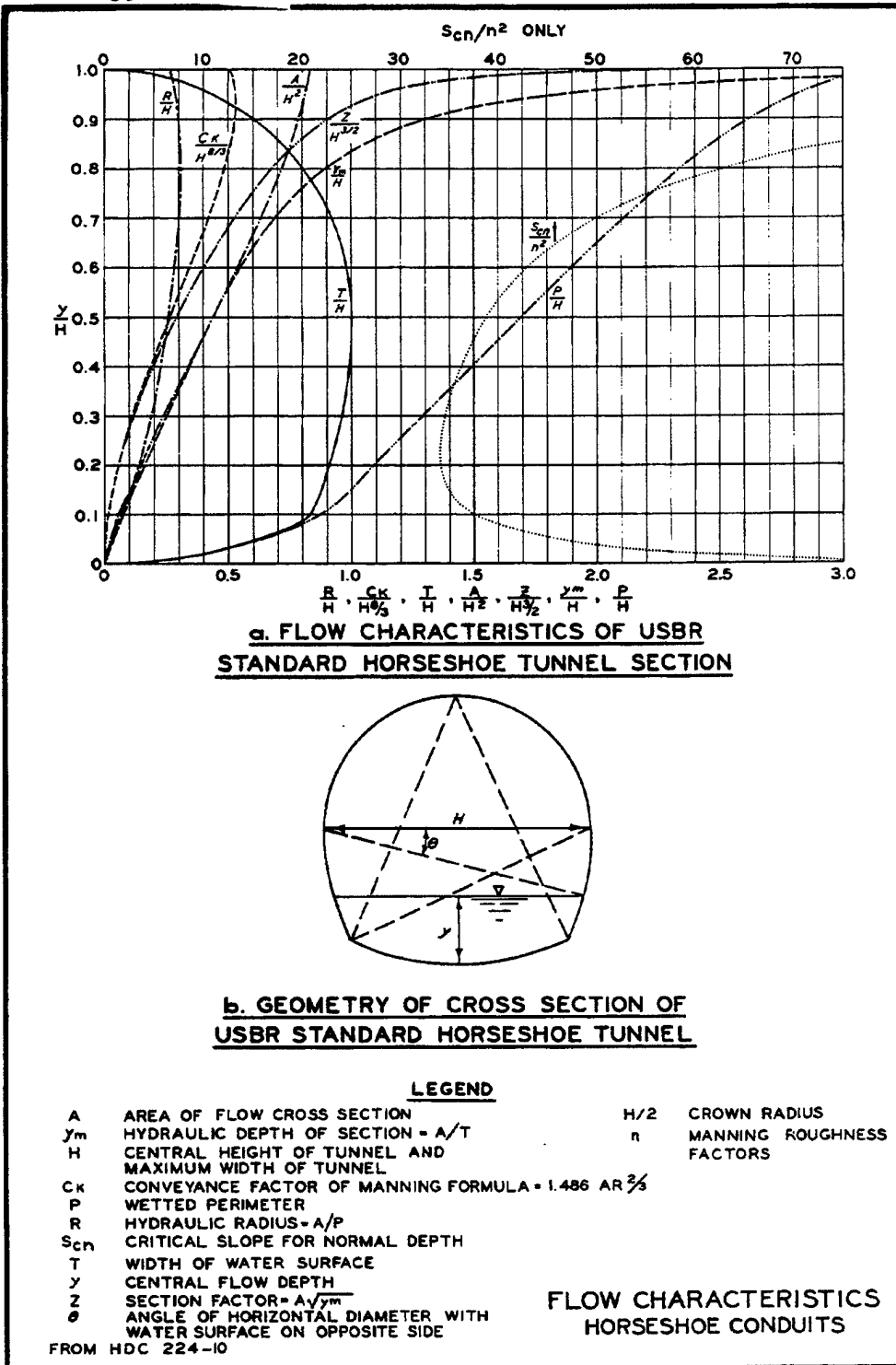

PLATE C-4

SECTION	AREA (A)	WETTED PERIMETER (P)	HYDRAULIC RADIUS (R)
 <p>RECTANGULAR SHAPE</p>	BH	$2(B+H)$	$\frac{BH}{2(B+H)}$
 <p>CIRCULAR SHAPE</p>	$\frac{\pi D^2}{4}$	πD	$\frac{D}{4}$
 <p>VERTICAL-SIDE HORSESHOE SHAPE</p>	$BH + \frac{\pi r^2}{2}$	$B + 2H + \pi r$	$\frac{BH + \frac{\pi r^2}{2}}{B + 2H + \pi r}$
 <p>OBLONG SHAPE</p>	$BH + \pi r^2$	$2(H + \pi r)$	$\frac{BH + \pi r^2}{2(H + \pi r)}$
 <p>SLOPING-SIDE HORSESHOE SHAPE</p>	$H(B + \Delta B) + \frac{\pi r^2}{2}$	$B + 2(H^2 + (\Delta B)^2)^{1/2} + \pi r$	$\frac{H(B + \Delta B) + \frac{\pi r^2}{2}}{B + 2(H^2 + (\Delta B)^2)^{1/2} + \pi r}$
 <p>CURVED-SIDE HORSESHOE SHAPE (USBR)</p>	$3.3172 r^2$	$6.5338 r$	$0.5077 r$

HYDRAULIC ELEMENTS
CONDUIT SECTIONS

FROM HDC 224-2



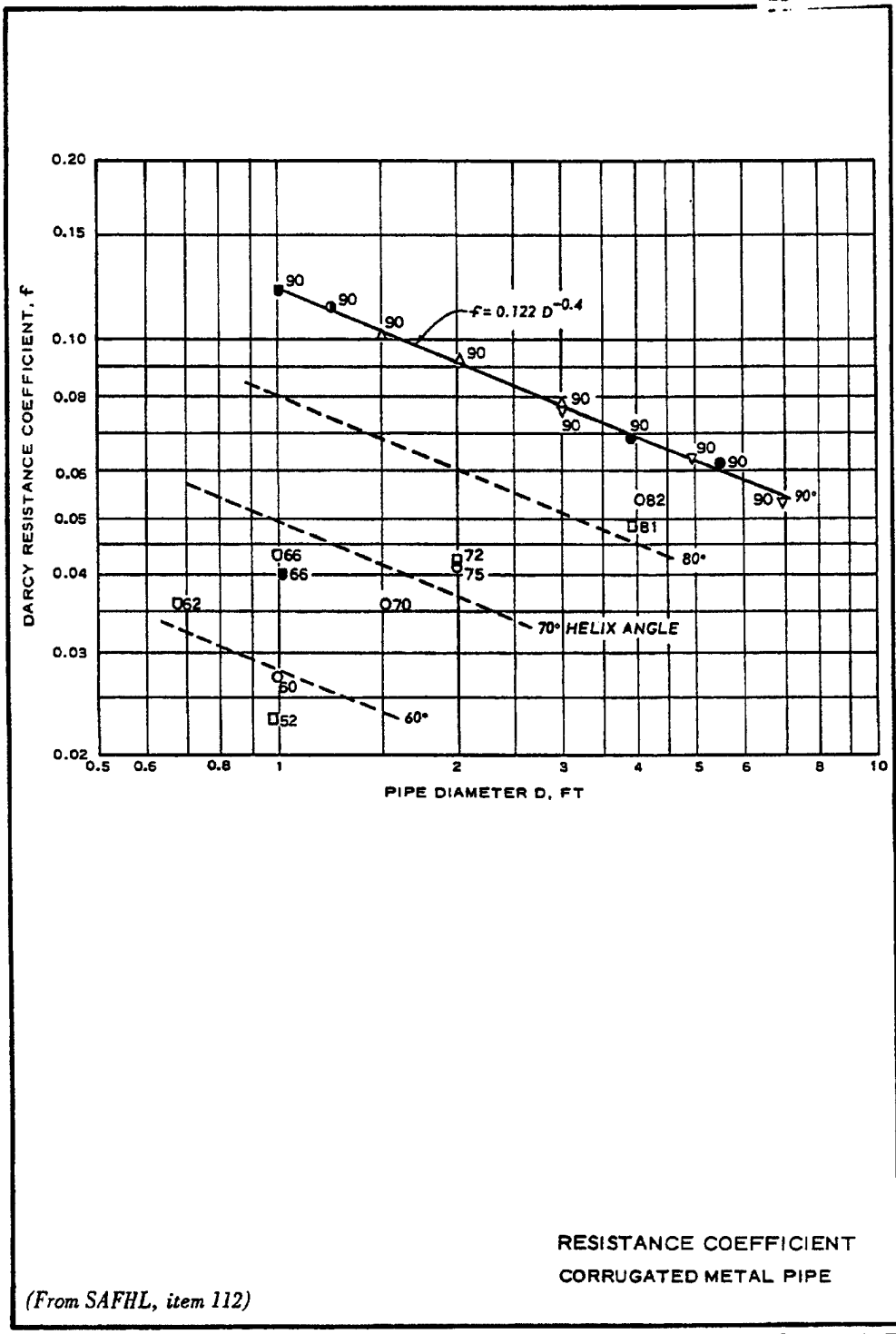

RESISTANCE COEFFICIENT
CORRUGATED METAL PIPE

(From SAFHL, item 112)

15 Oct 80

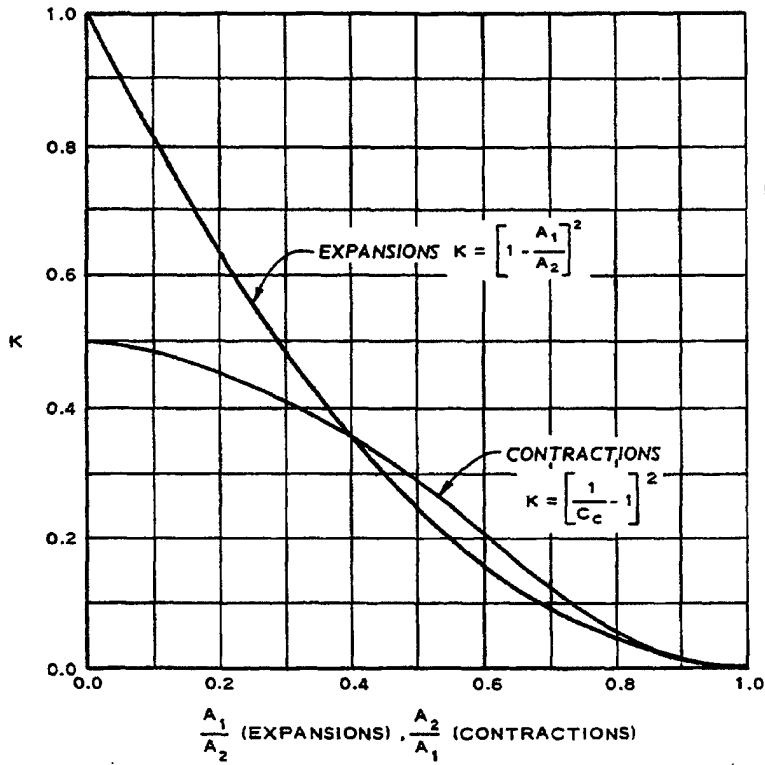

EXPANSIONS

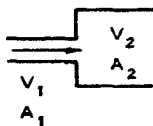

$$h_l = K \frac{V_1^2}{2g}$$

CONTRACTIONS

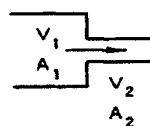

$$h_l = K \frac{V_2^2}{2g}$$

WHERE

h_l = HEAD LOSS, FT

K = LOSS COEFFICIENT

V = REFERENCE CONDUIT VELOCITY, FPS

A = CROSS-SECTION AREA, FT²

g = ACCELERATION OF GRAVITY, FT/SEC²

C_c = CONTRACTION COEFFICIENT
(FROM WEISBACH)

HEAD LOSS COEFFICIENTS
ABRUPT TRANSITIONS

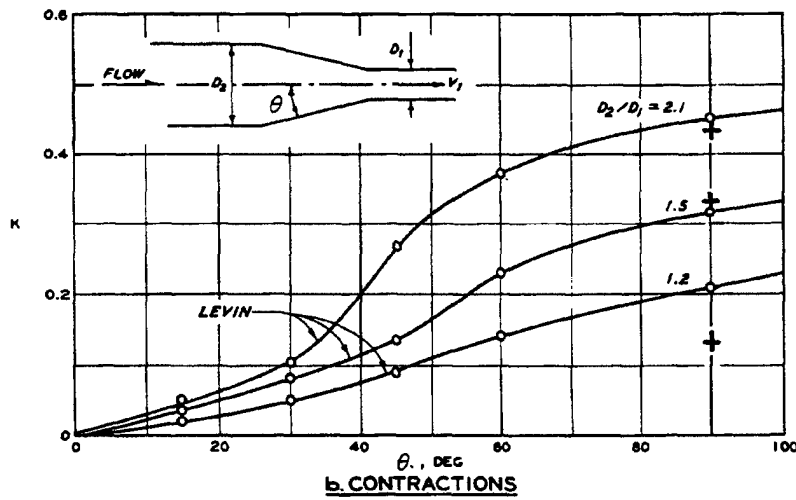
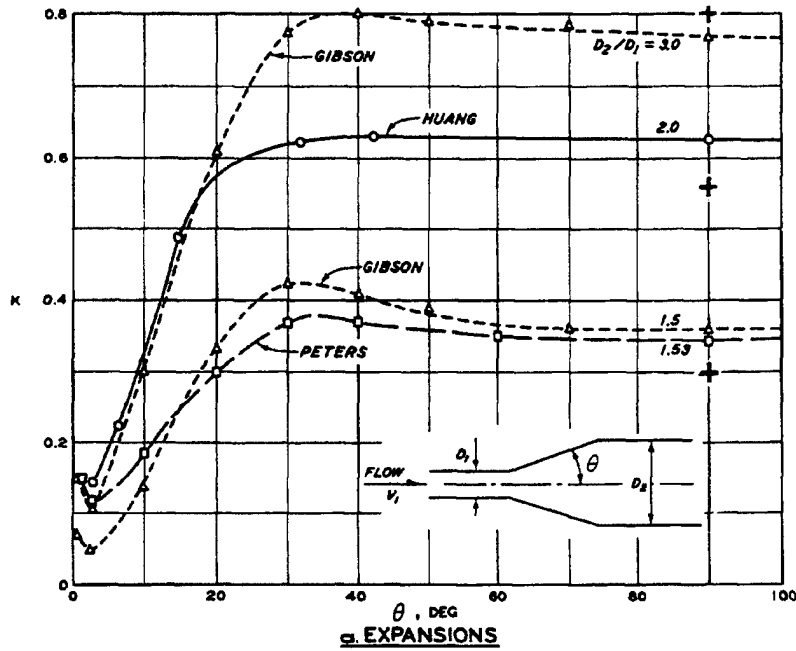

BASIC EQUATION

$$K = \frac{h_f}{V^2/2g}$$

WHERE:

- h_f = HEAD LOSS, FT
- g = ACCELERATION OF GRAVITY, FT/SEC²
- V_1 = AVERAGE VELOCITY IN THE SMALLER CONDUIT, FPS

† FROM PLATE C-8 FOR $\theta = 90^\circ$.

LOSS COEFFICIENTS
CONICAL TRANSITIONS

FROM HDC 228-4

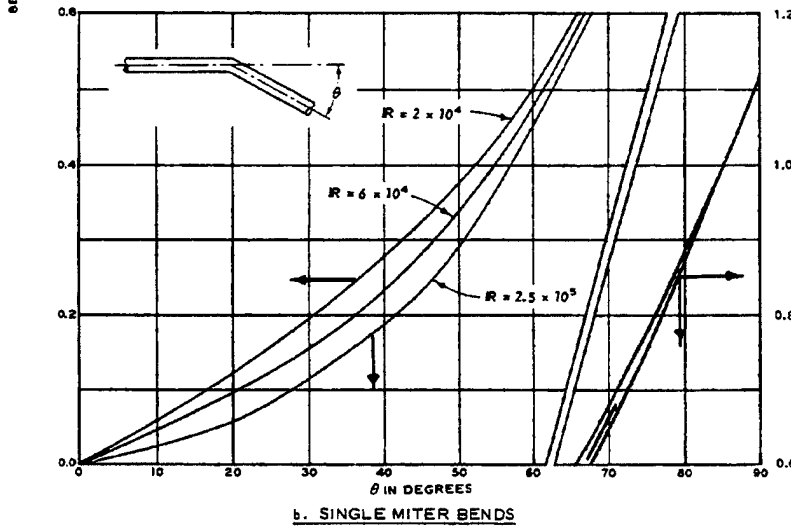
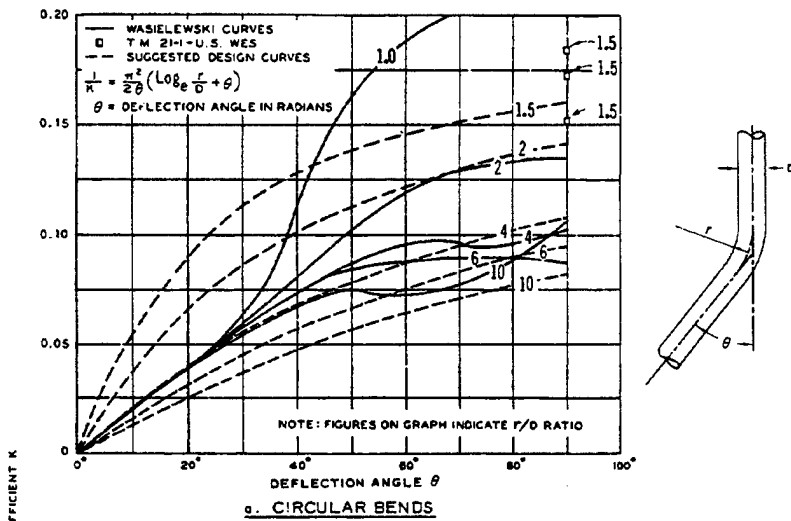

BASIC EQUATION

$$K = \frac{h_L}{v^2/2g}$$

WHERE K = BEND LOSS COEFFICIENT
 h_L = HEAD LOSS DUE TO BEND

BEND LOSS COEFFICIENTS
 CIRCULAR CONDUITS

FROM HDC 228-1 AND 228-2/1

**LOSS COEFFICIENTS
CIRCULAR CONDUITS
MULTIPLE MITER BENDS**

(From SAFH, for U. S. Navy, item 4)

BASIC EQUATION

$$h_b = K \frac{V^2}{2g}$$

WHERE:

- h_b = HEAD LOSS DUE TO BEND, FT
- K = BEND LOSS COEFFICIENT
- V = FLOW VELOCITY, FPS
- g = ACCELERATION OF GRAVITY, FT/SEC²
- REYNOLDS NUMBER ABOUT 225,000

D/D	K _S	K _T
0.71	0.507	0.510
0.84	0.350	0.475
1.17	0.333	0.384
1.42	0.261	0.377
1.50	0.280	0.376
1.85	0.285	0.390
2.56	0.356	0.479
3.14	0.346	0.475
3.72	0.356	0.450
4.89	0.389	0.455
5.59	0.392	0.444
6.28	0.399	0.444

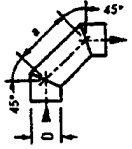

$K_S = 0.112$
 $K_T = 0.284$

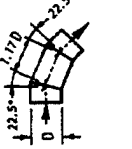

$K_S = 0.034$
 $K_T = 0.044$

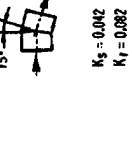

$K_S = 0.042$
 $K_T = 0.082$

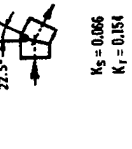

$K_S = 0.066$
 $K_T = 0.154$



$K_S = 0.130$
 $K_T = 0.185$

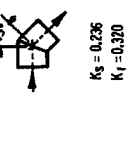

$K_S = 0.236$
 $K_T = 0.320$

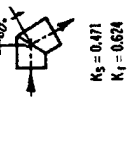

$K_S = 0.471$
 $K_T = 0.624$

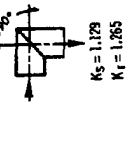

$K_S = 1.129$
 $K_T = 1.265$

D/D	K _S	K _T
1.19	0.120	0.294
1.40	0.125	0.282
1.50	-	0.290
1.63	0.124	0.256
1.86	0.117	0.272
2.32	0.095	0.317
2.40	0.095	-
2.91	0.108	0.317
3.49	0.130	0.318
4.55	0.146	0.310
6.05	0.142	0.313

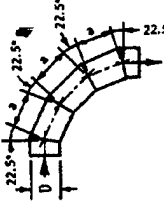

$K_S = 0.108$
 $K_T = 0.256$

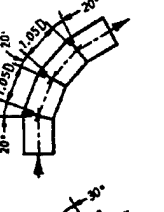

$K_S = 0.188$
 $K_T = 0.320$

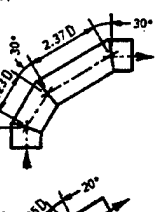

$K_S = 0.202$
 $K_T = 0.323$

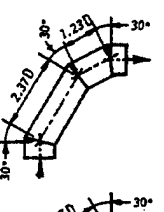

$K_S = 0.400$
 $K_T = 0.534$

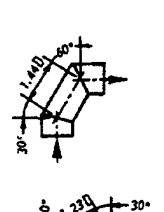

$K_S = 0.400$
 $K_T = 0.601$

D/D	K _S	K _T
1.23	0.195	0.347
1.44	0.195	0.320
1.67	0.190	0.300
1.91	0.149	0.299
1.91	0.154	0.312
2.37	0.167	0.337
2.96	0.172	0.342
4.11	0.190	0.354
4.70	0.192	0.360
6.10	0.201	0.330

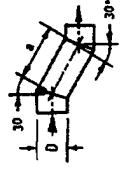

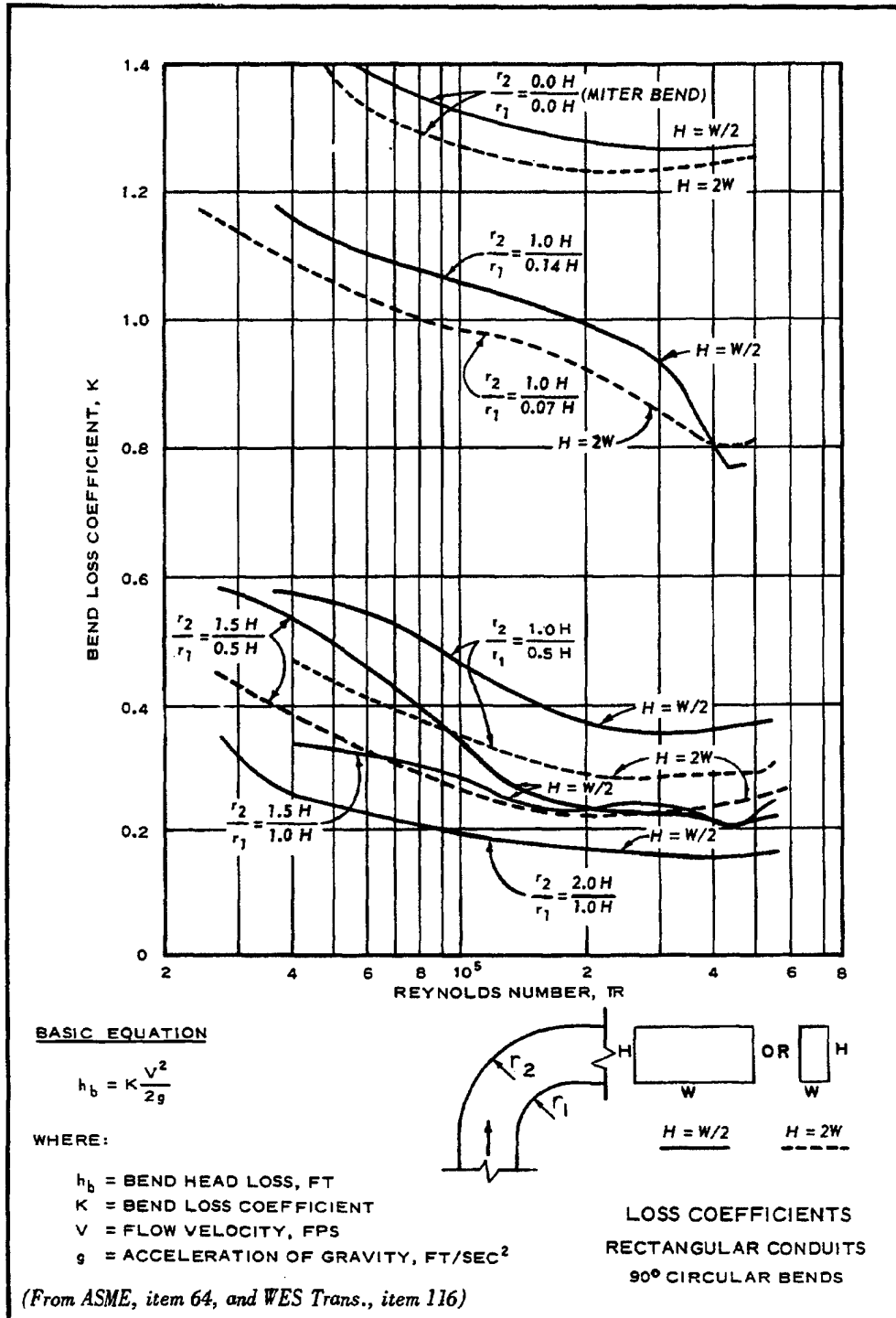

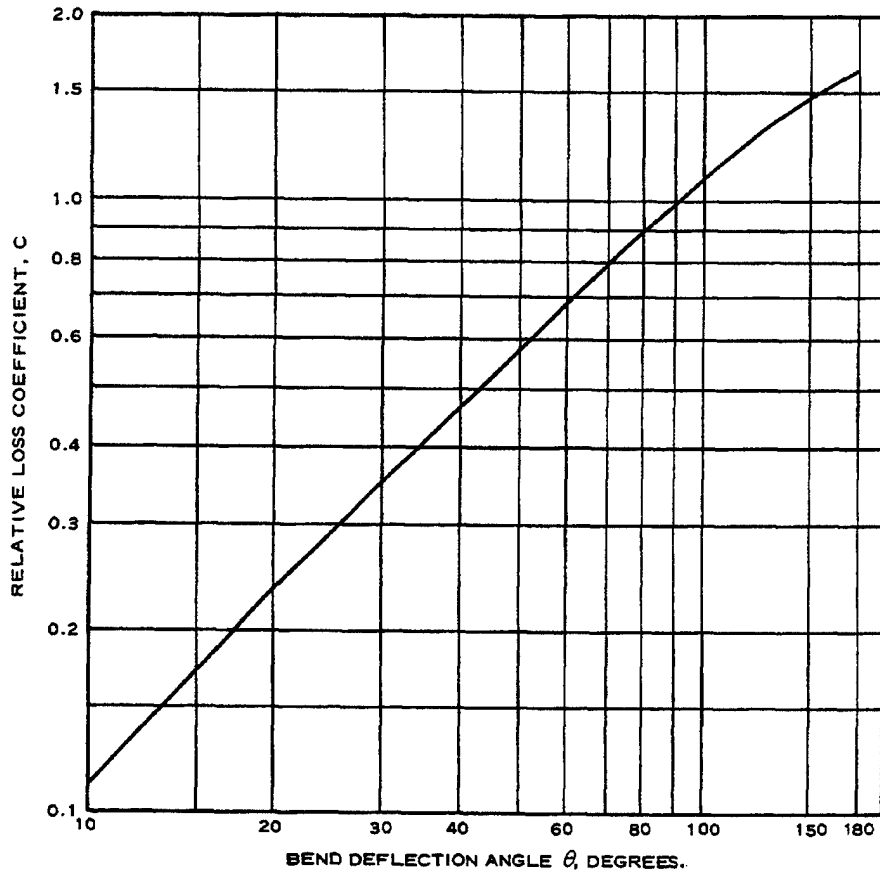

BASIC EQUATION

$$h_b = CK \frac{v^2}{2g}$$

WHERE

- h_b = BEND HEAD LOSS, FT
- C = RELATIVE LOSS COEFFICIENT
- K = 90° BEND LOSS COEFFICIENT (PLATE 12)
- V = CONDUIT VELOCITY, FPS
- g = ACCELERATION OF GRAVITY, FT/SEC²
- REYNOLDS NUMBER ABOUT 200,000

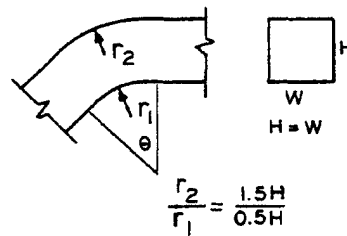

RELATIVE LOSS COEFFICIENTS
RECTANGULAR CONDUITS
CIRCULAR BENDS

(From ASME, item 64)

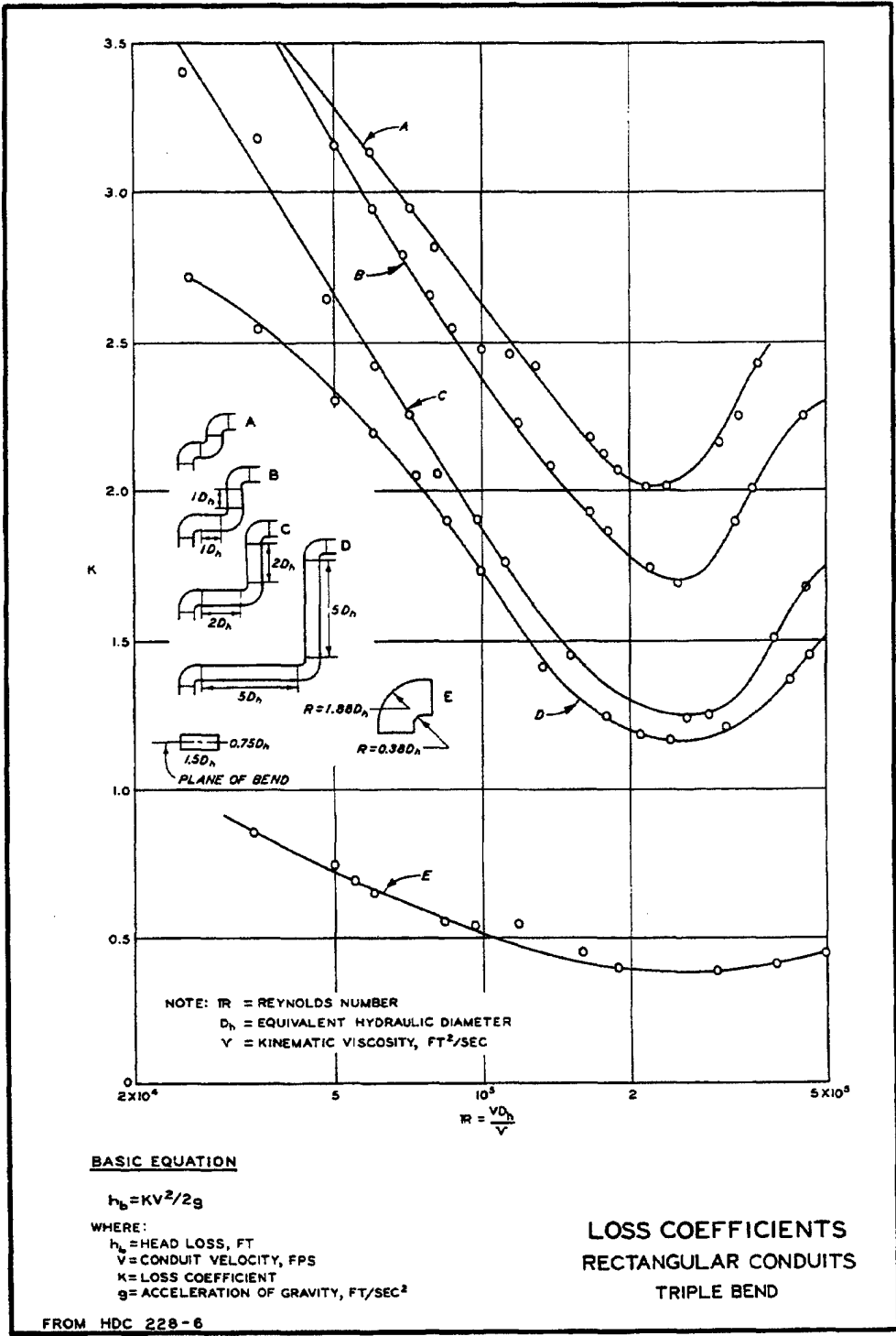

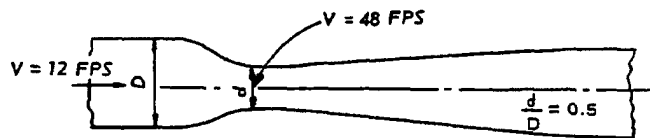
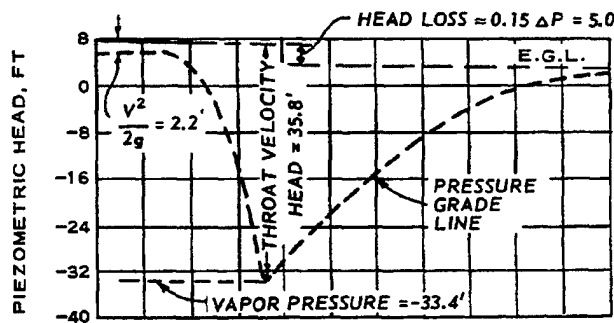

a. VENTURI METER

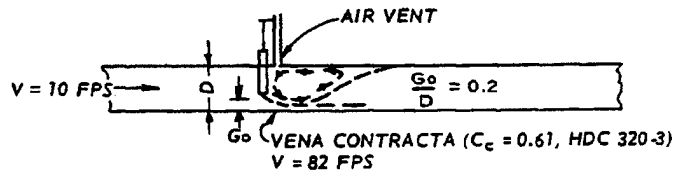
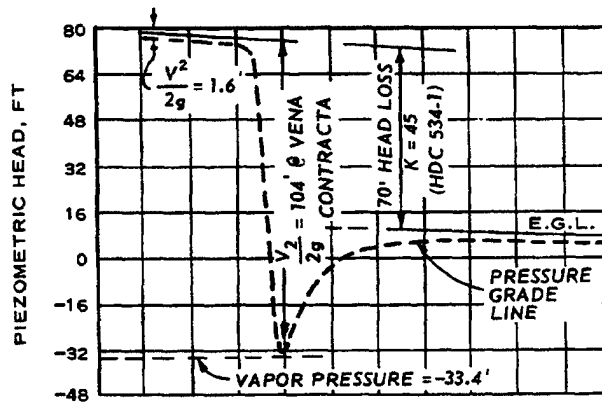

b. IN-LINE GATE

PHYSICAL CONDITIONS:
ATMOSPHERIC PRESSURE = 33.8 FT
AT 50°F AT SEA LEVEL (HDC 000-2)
VAPOR PRESSURE = 0.17 PSIA = 0.4 FT
AT 50°F (HDC 001-2)

EXAMPLES OF
CAVITATION HYDRAULICS

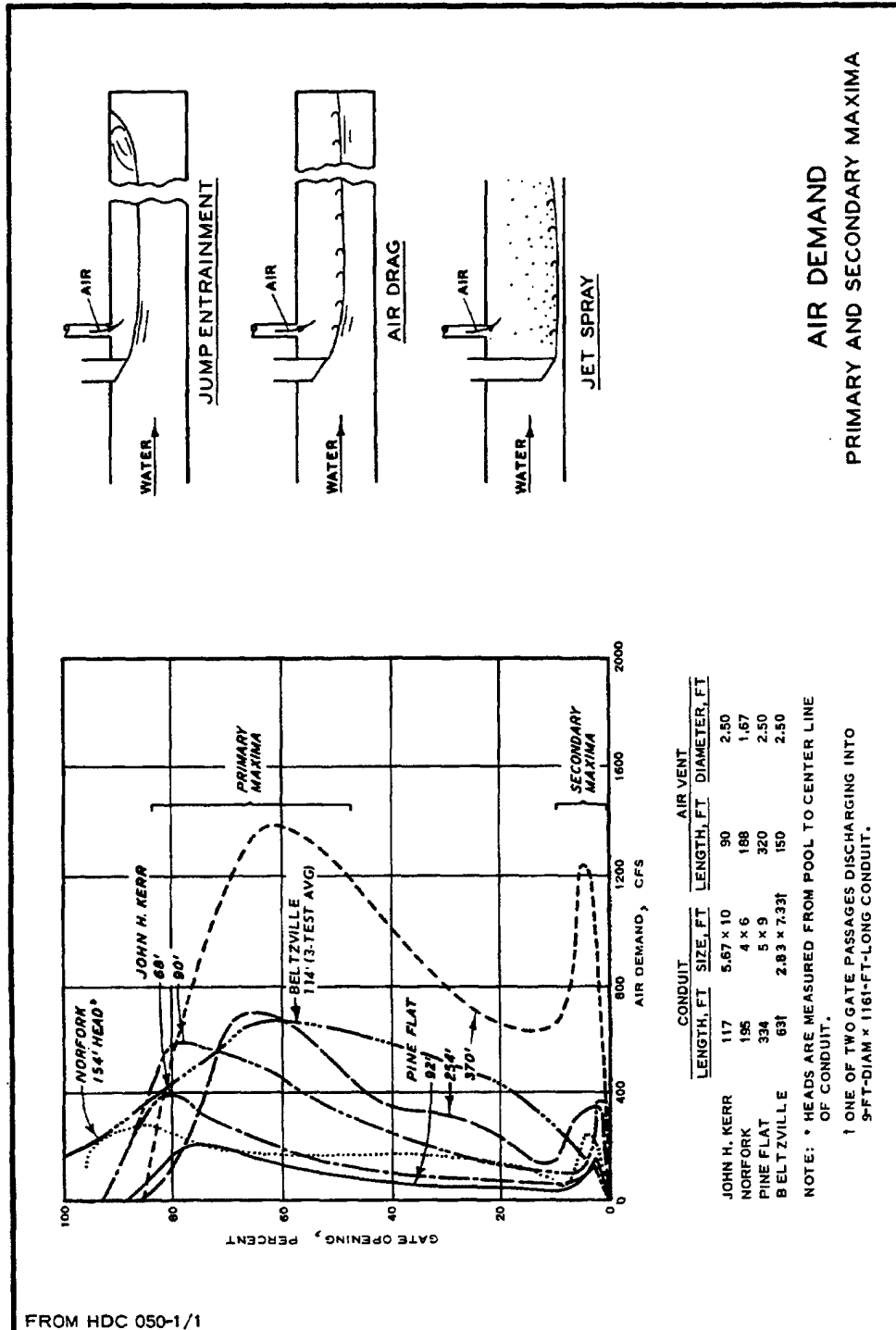

AIR DEMAND
PRIMARY AND SECONDARY MAXIMA

FROM HDC 050-1/1

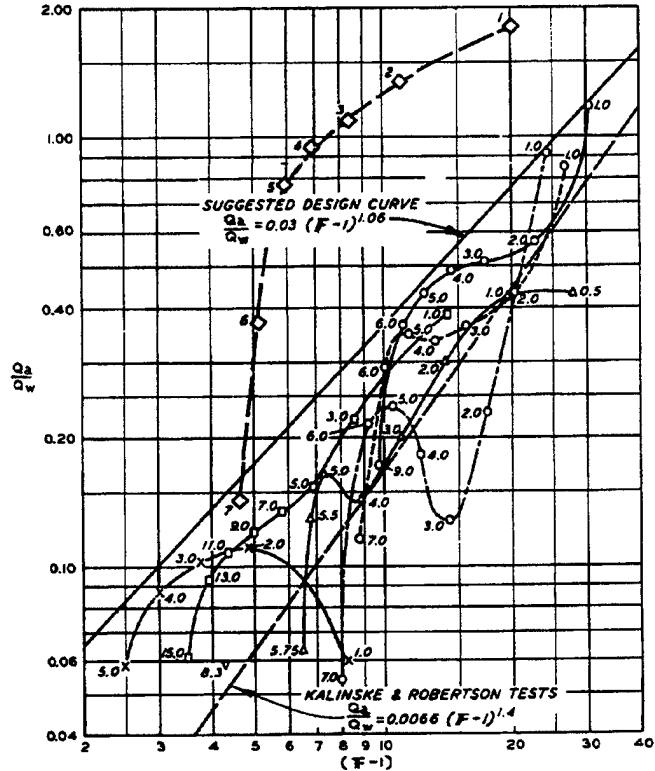

NOTE : $F = V/\sqrt{gy}$ (FROUDE NUMBER)
 V = WATER VELOCITY AT VENA CONTRACTA, FPS
 y = WATER DEPTH AT VENA CONTRACTA, FT
 Q_a = AIR DEMAND, CFS
 Q_w = WATER DISCHARGE, CFS

AIR PROPERTIES
AT SEA LEVEL ATMOSPHERIC PRESSURE

TEMP °F	KINEMATIC VISCOSITY FT ² /SEC	DENSITY SLUG/FT ³	SPECIFIC WEIGHT LB/FT ³
80	1.69×10^{-4}	2.28×10^{-3}	7.35×10^{-2}
60	1.58×10^{-4}	2.37×10^{-3}	7.63×10^{-2}
40	1.46×10^{-4}	2.47×10^{-3}	7.94×10^{-2}

LEGEND

- PINE FLAT - H = 370 FT
- PINE FLAT - H = 304 FT
- PINE FLAT - H = 254 FT
- DENISON - H = 84 FT
- x HULAH - H = 24 FT
- △ NORFORK - H = 154 FT
- ▽ TYGART - H = 92 FT
- ◇ BELTZVILLE H = 114 FT
(3-TEST AVG)*

H = HEAD, POOL TO CONDUIT CENTER LINE
 FIGURES ON GRAPH SHOW GATE
 OPENING IN FEET.

* PROBABLY FREE FLOW
 CONDITION

AIR DEMAND

EM 1110-2-1602
15 Oct 80

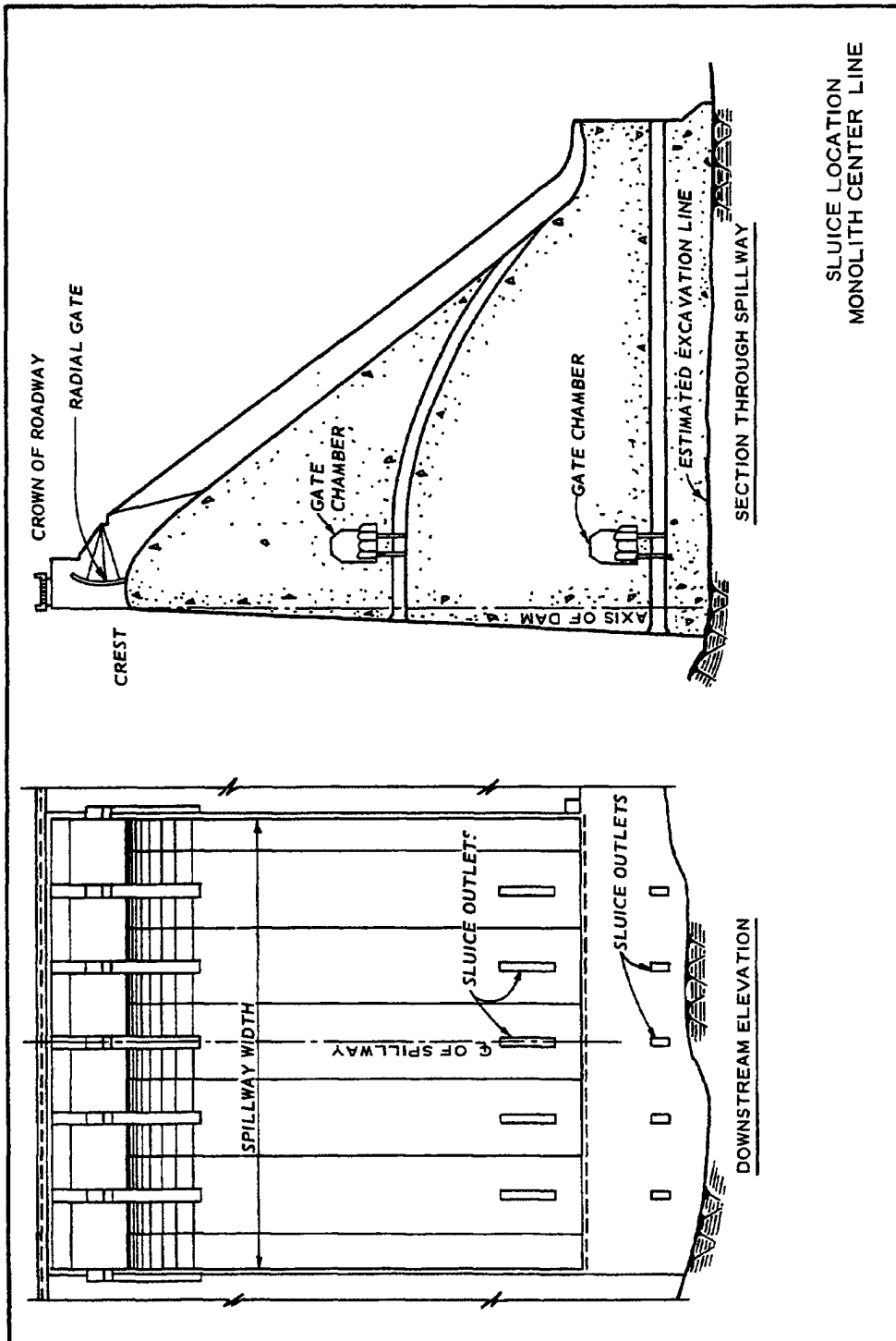

SLUICE LOCATION
MONOLITH CENTER LINE

PLATE C-18

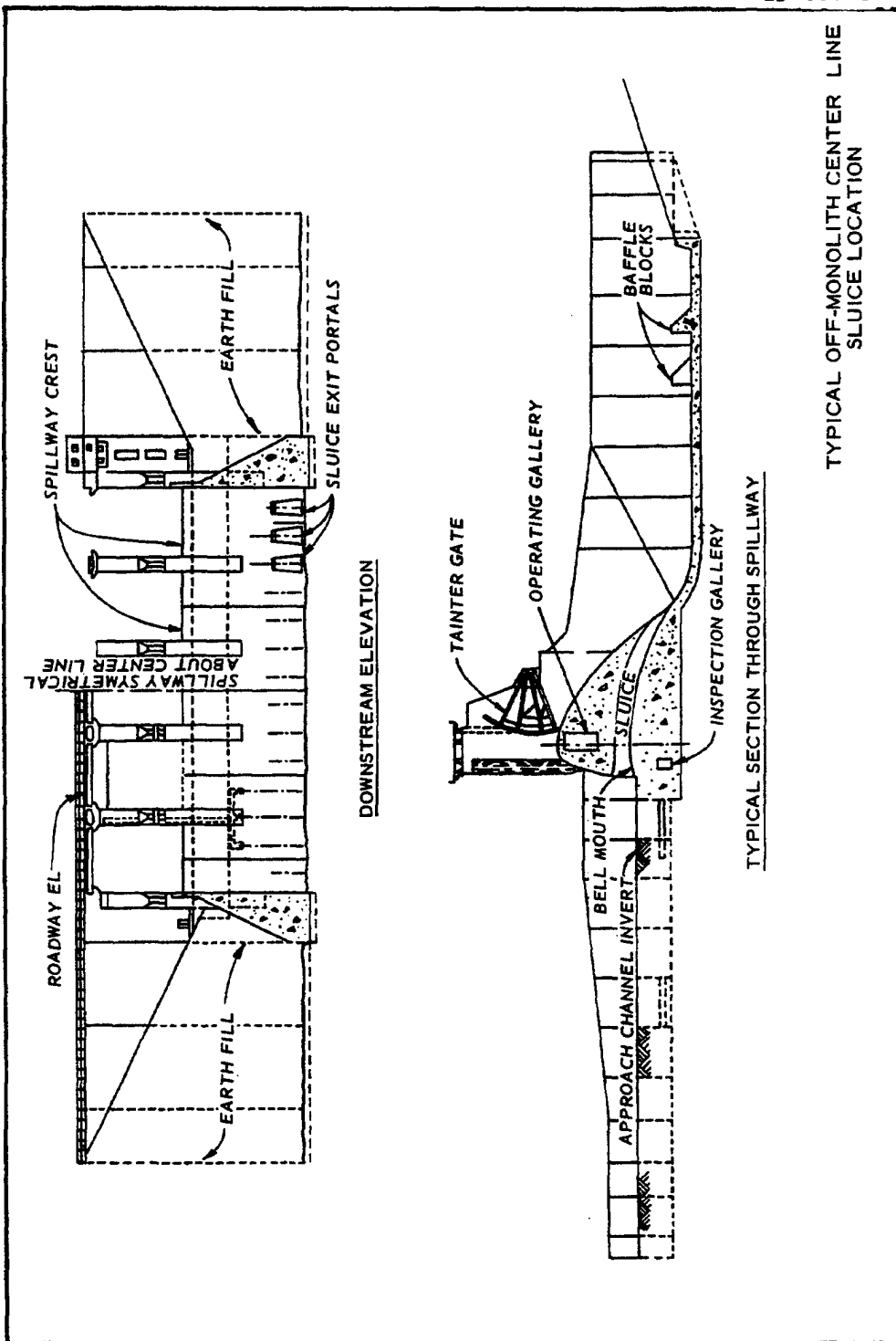

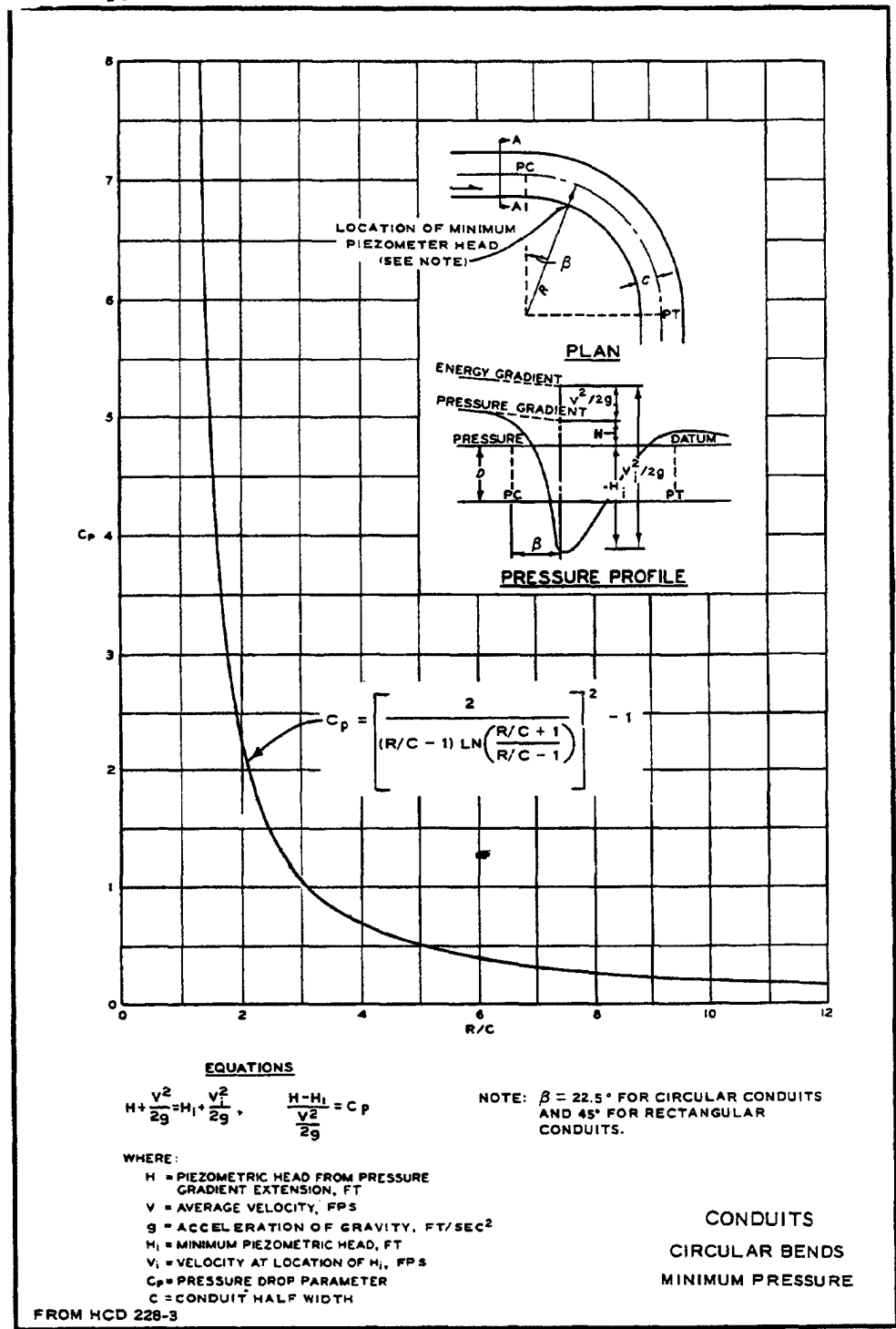

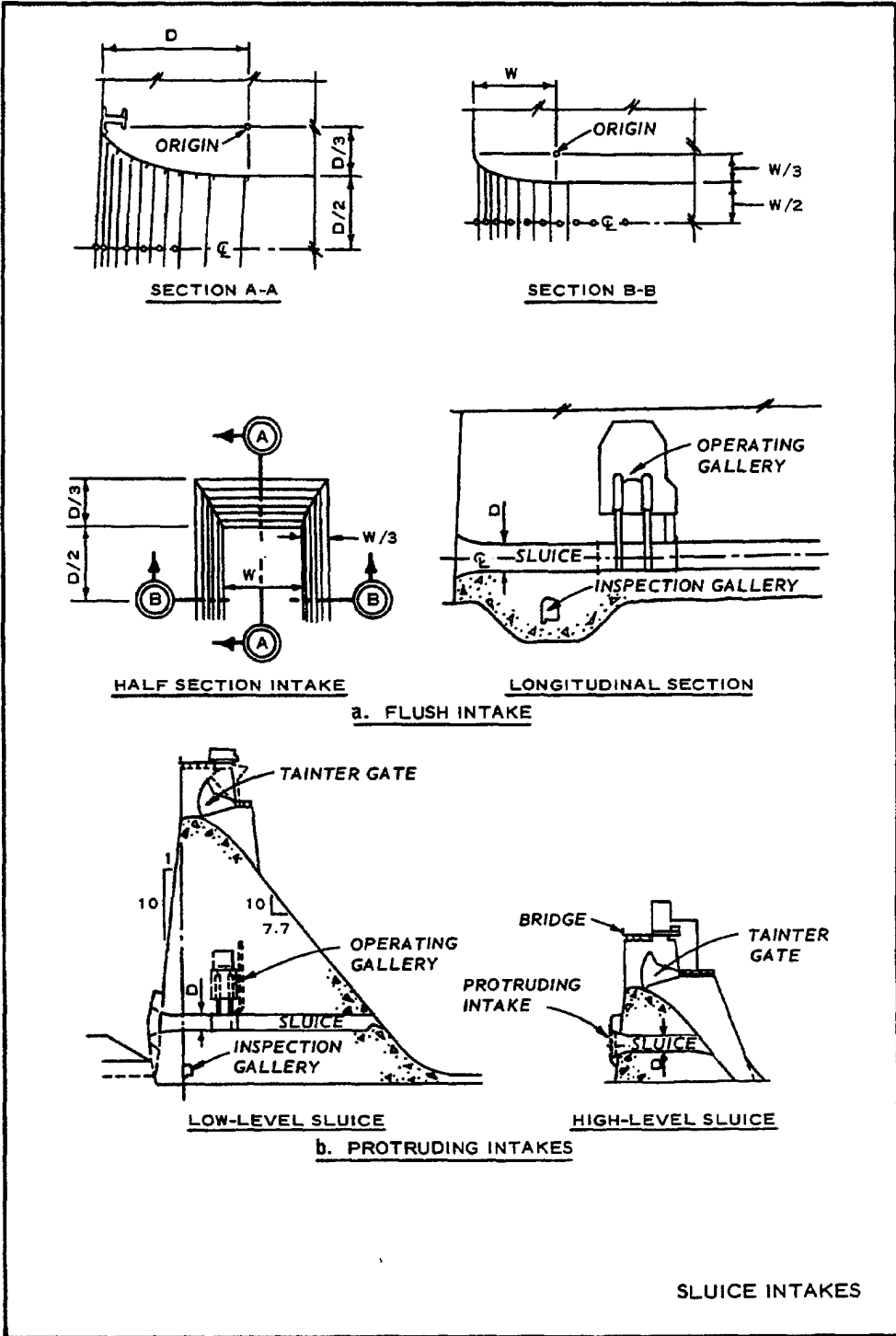

SLUICE INTAKES

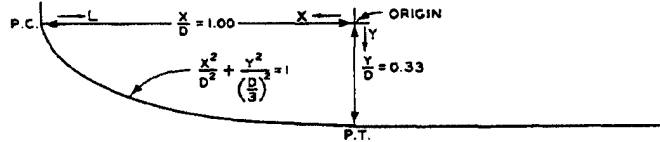
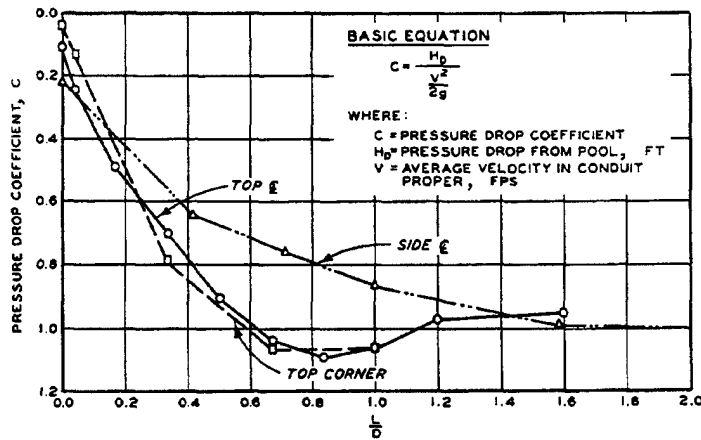

a. SIMPLE CURVES

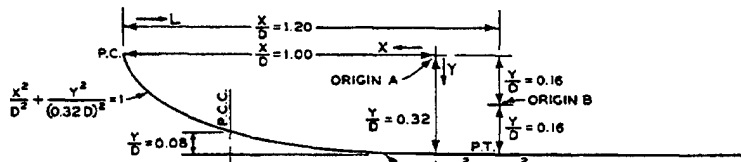
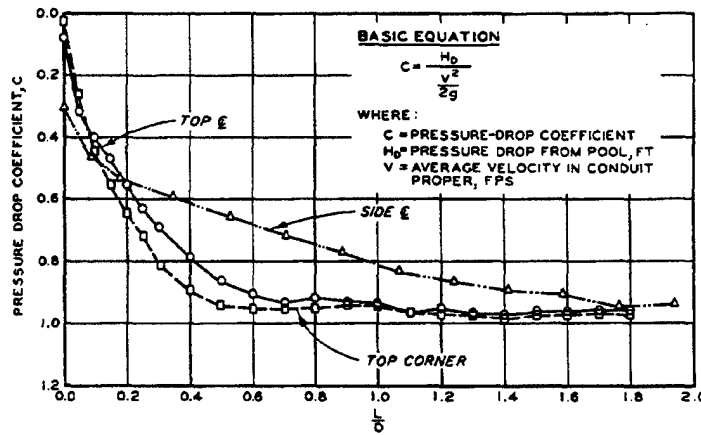

NOTE:
 CONDUIT HEIGHT = 1.765
 CONDUIT WIDTH

D = DIMENSION OF CONDUIT IN DIRECTION CONCERNED, FT
 L = DISTANCE ALONG CONDUIT, FT

b. COMPOUND CURVES

**PRESSURE DROP COEFFICIENTS
 SLUICE ENTRANCES**

FROM HDC 211-1, 1/1

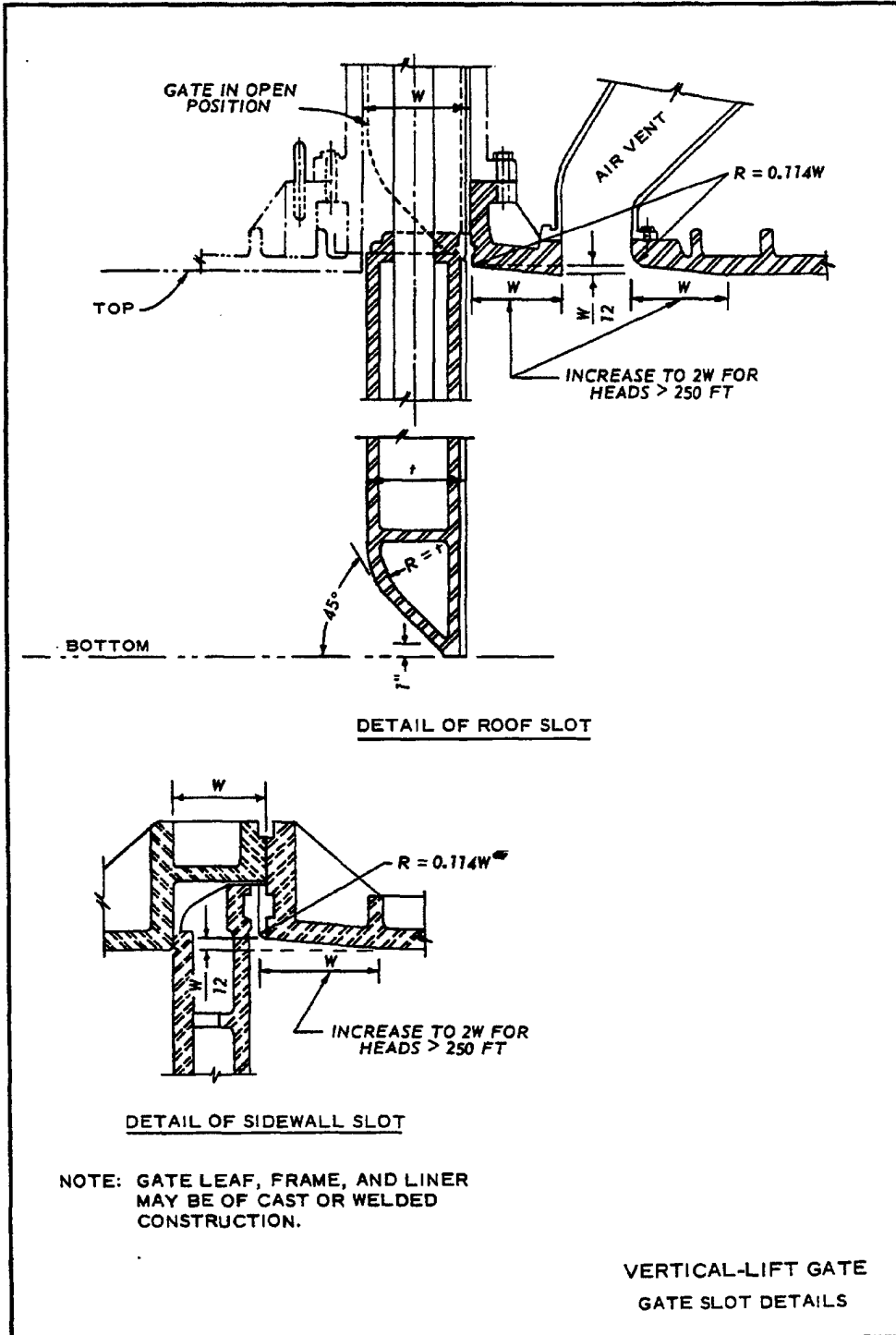

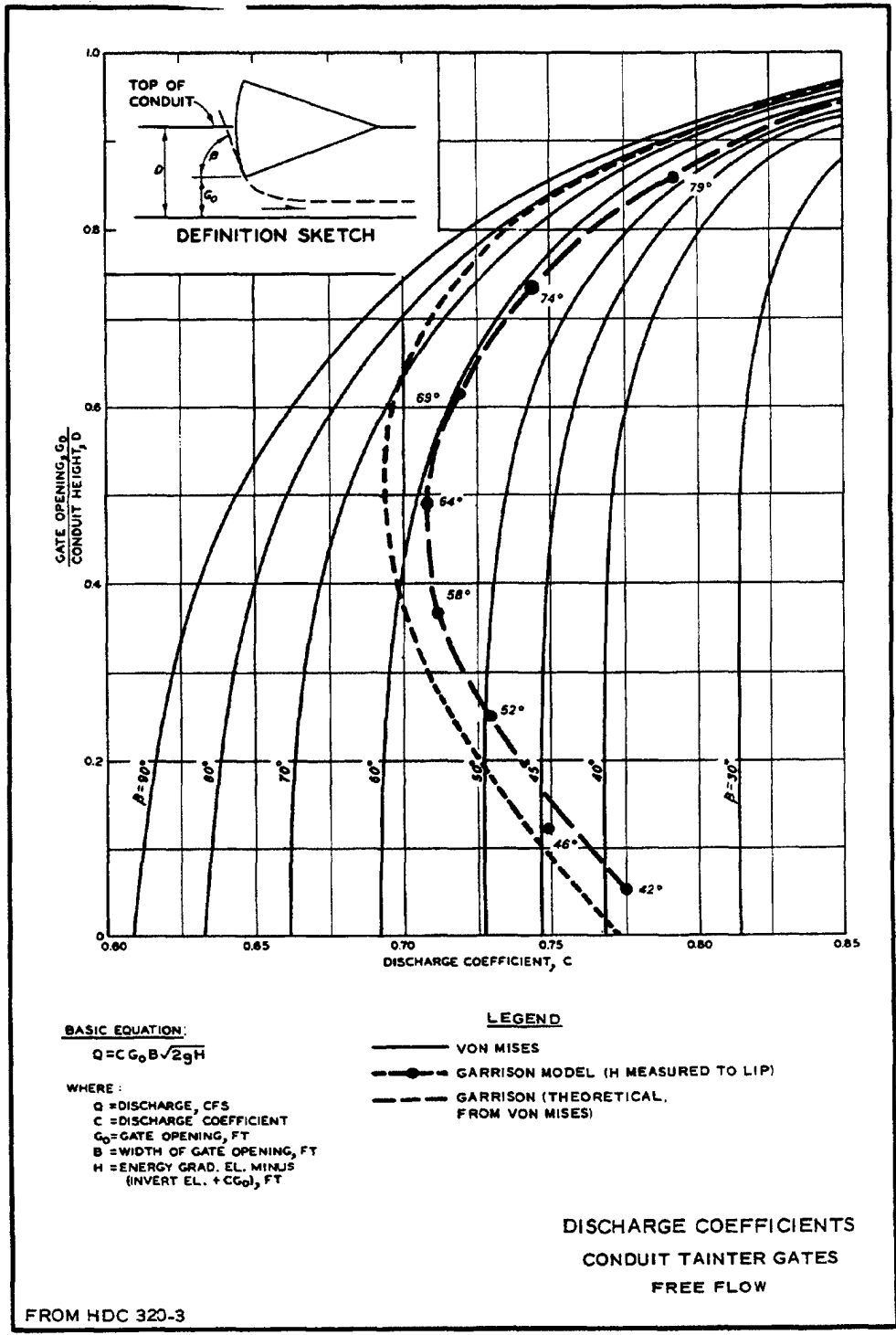

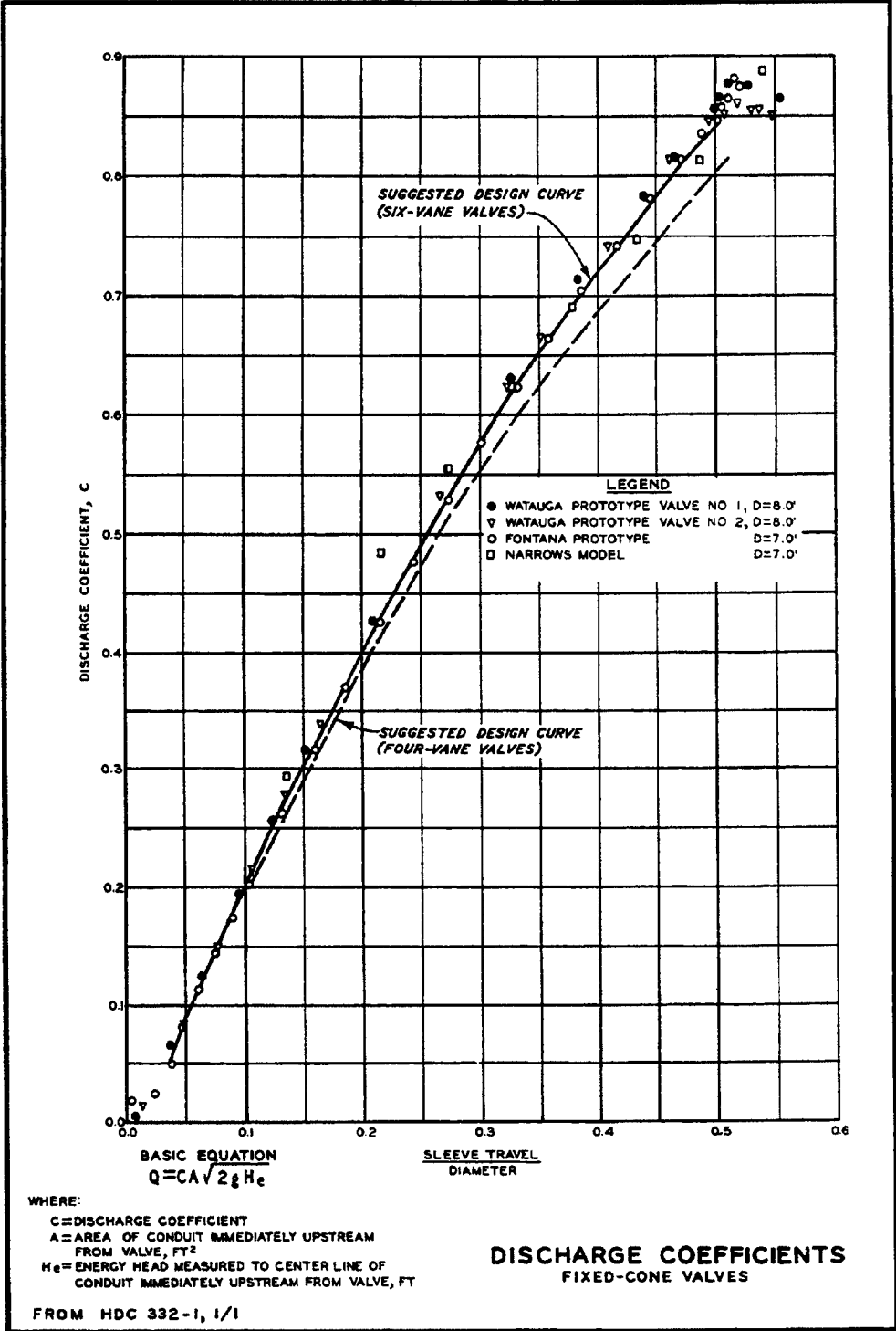

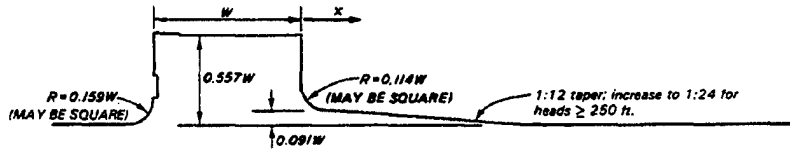
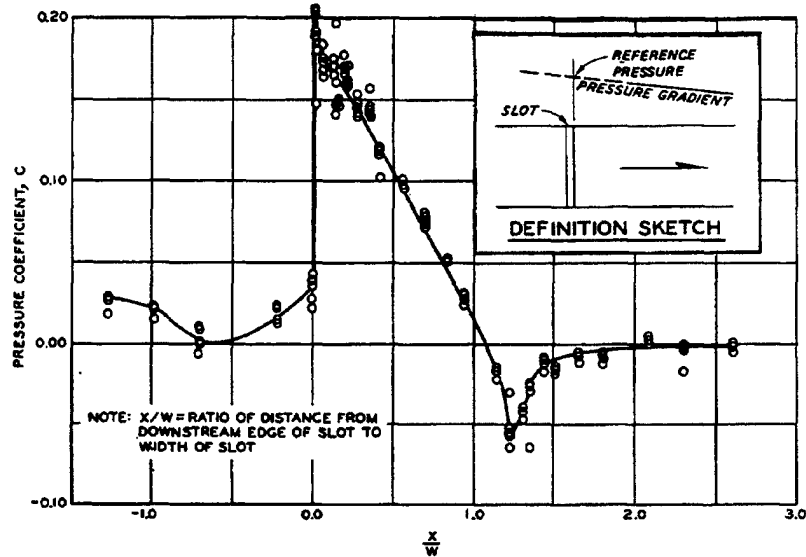

a. PRESSURE DETAILS

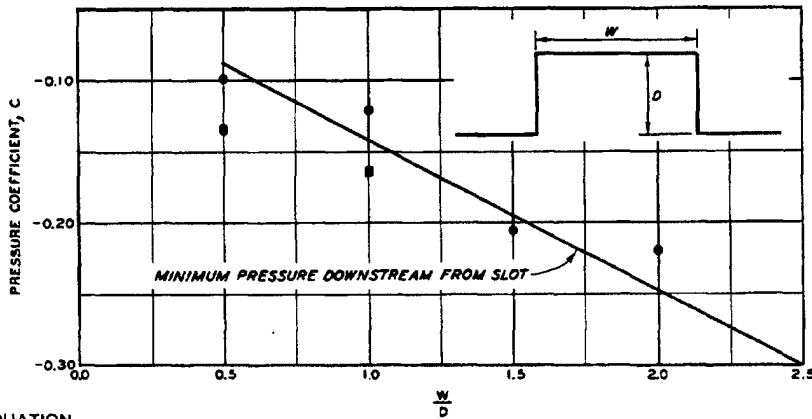

EQUATION

$$H_d = CH_v$$

WHERE:

H_d = PRESSURE DIFFERENCE FROM REFERENCE PRESSURE, FT

C = PRESSURE COEFFICIENT

H_v = CONDUIT VELOCITY HEAD AT REFERENCE PRESSURE STATION, FT

b. MINIMUM PRESSURE

PRESSURE COEFFICIENTS
GATE SLOT

FROM HDC 212-1/1. 1/2

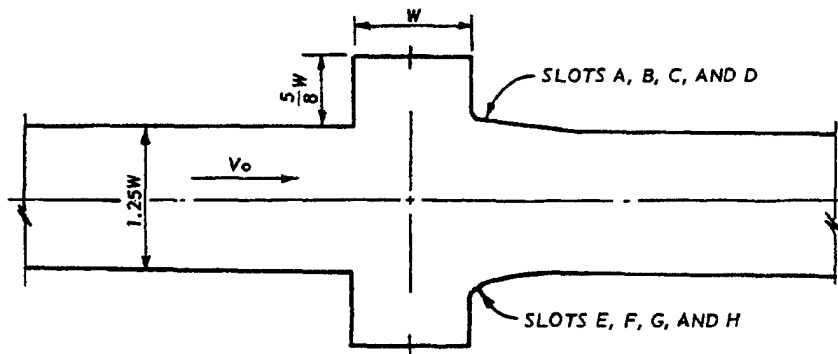

PLAN

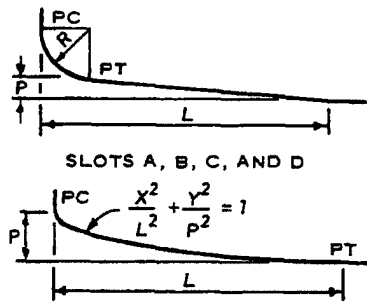

DIMENSIONS RELATIVE TO W				σ_i
SLOT TYPE	R	P	L	
A	0.425	0.200	2.50	0.36
B	0.425	0.425	5.00	0.29
C	0.725	0.625	7.50	0.28
D	1.025	0.825	10.00	0.22
E	--	0.425	2.50	0.36
F	--	0.825	5.00	0.29
G	--	1.250	7.50	0.24
H	--	1.675	10.00	0.27

SLOTS A, B, C, AND D
SLOTS E, F, G, AND H
DOWNSTREAM PLAN OF GATE SLOTS

NOTE: CONDUIT HEIGHT = 0.708W

a. GATE SLOTS

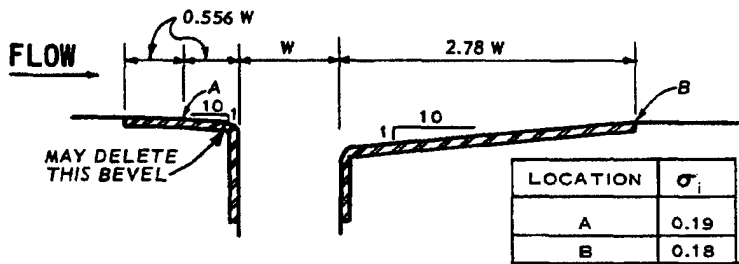

LOCATION	σ_i
A	0.19
B	0.18

b. AIR VENT AND DRAIN INLET PROFILE

BASIC EQUATION:

$$\sigma = \frac{h_o - h_v}{\frac{V_o^2}{2g}}; \text{ IF } \sigma > \sigma_i, \text{ CAVITATION WILL NOT OCCUR}$$

WHERE:

- V_o = CONDUIT VELOCITY, FPS
- h_o = PRESSURE HEAD IN UNDISTURBED FLOW, FT
- h_v = VAPOR PRESSURE OF WATER, FT
- σ = CAVITATION INDEX COEFFICIENT
- g = ACCELERATION OF GRAVITY, FT/SEC²

INCIPIENT CAVITATION
COEFFICIENTS FOR SLOTS

EM 1110-2-1602
15 Oct 80

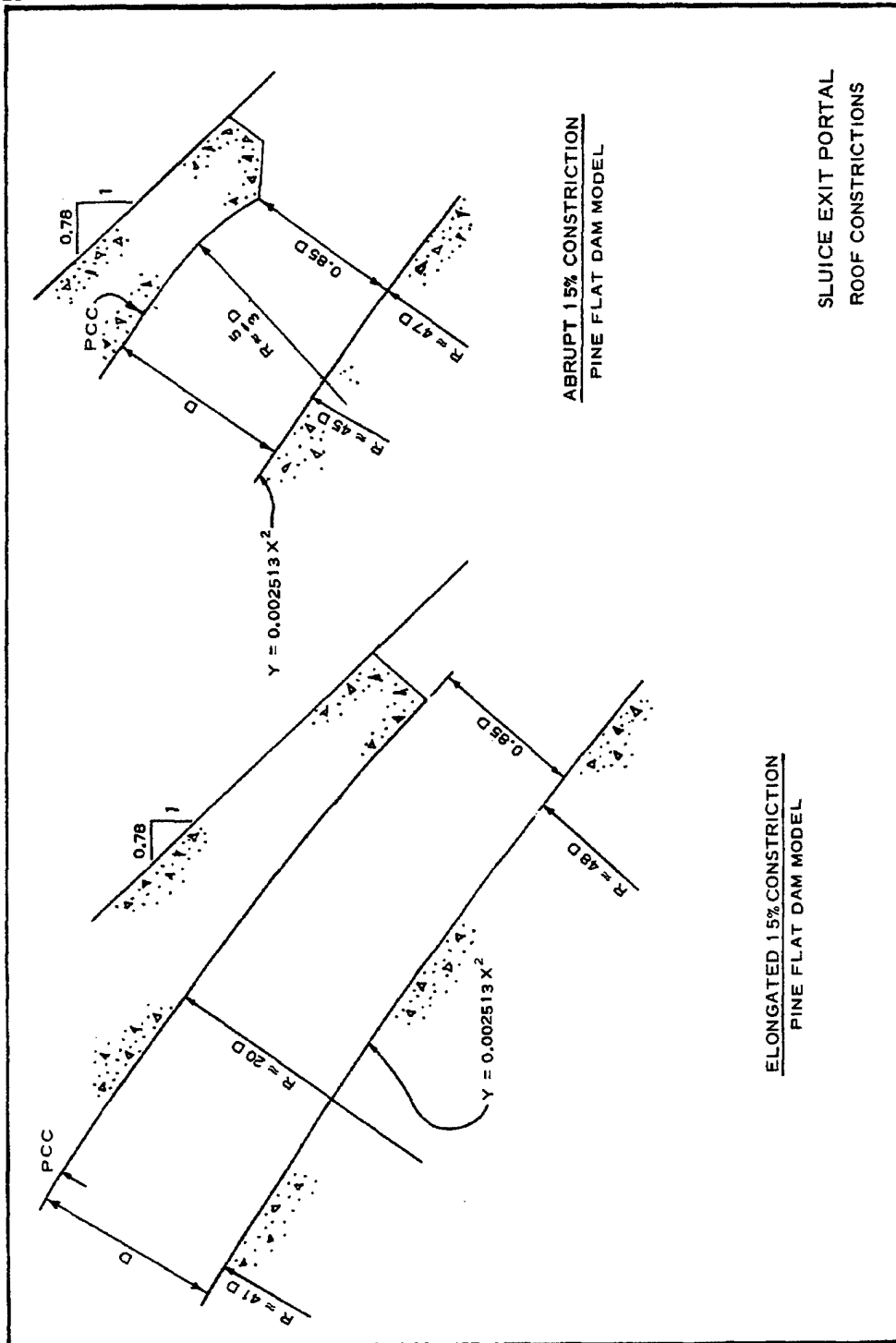
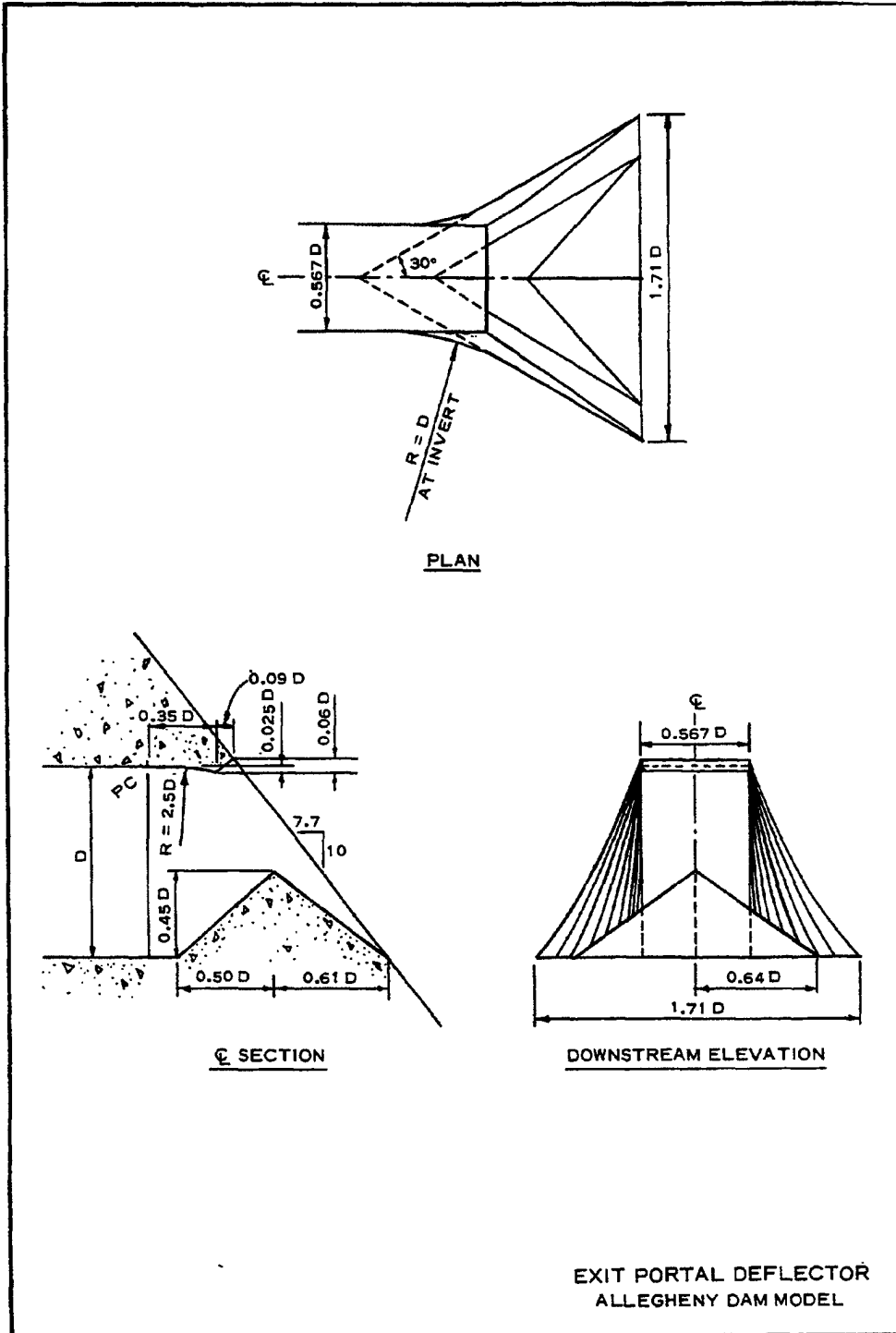
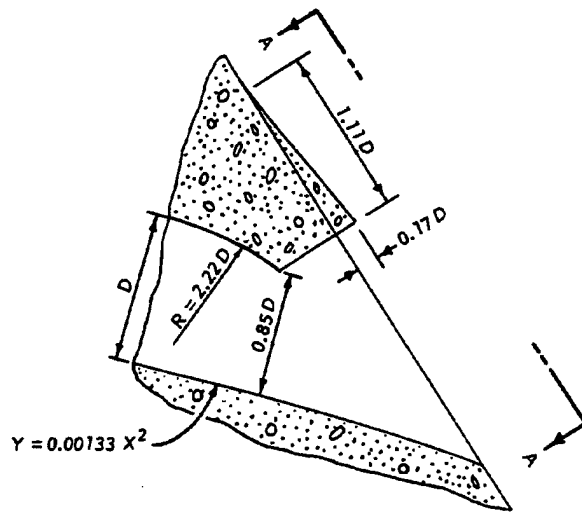
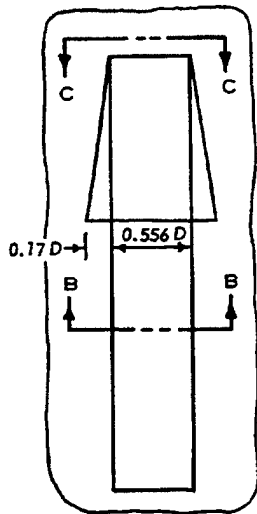

PLATE C-28





ELEVATION



VIEW A - A

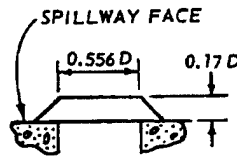

VIEW B - B

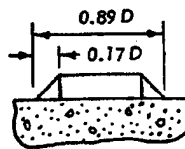

VIEW C - C

SLUICE EYEBROW DEFLECTOR
FOLSOM DAM MODEL

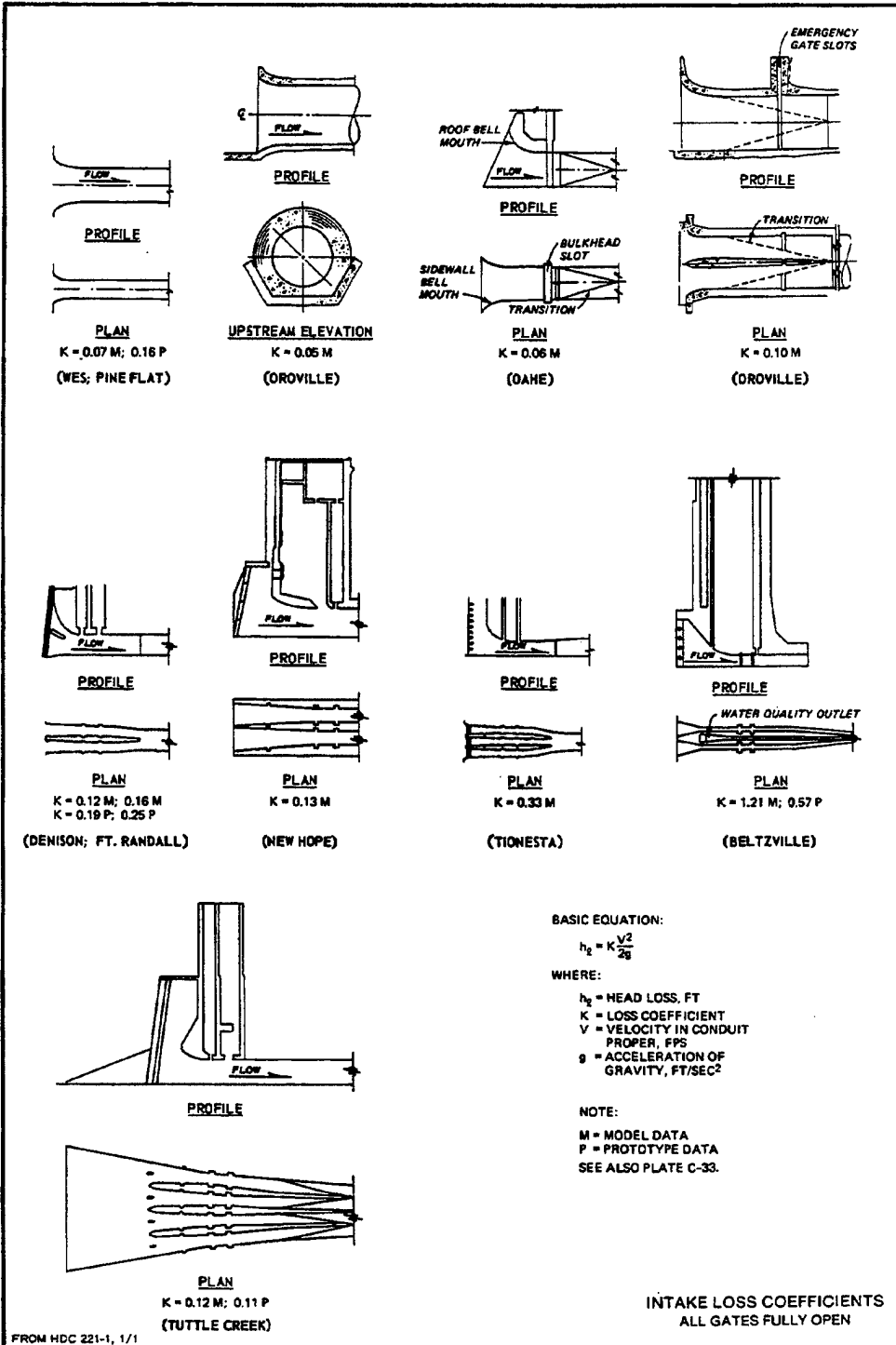

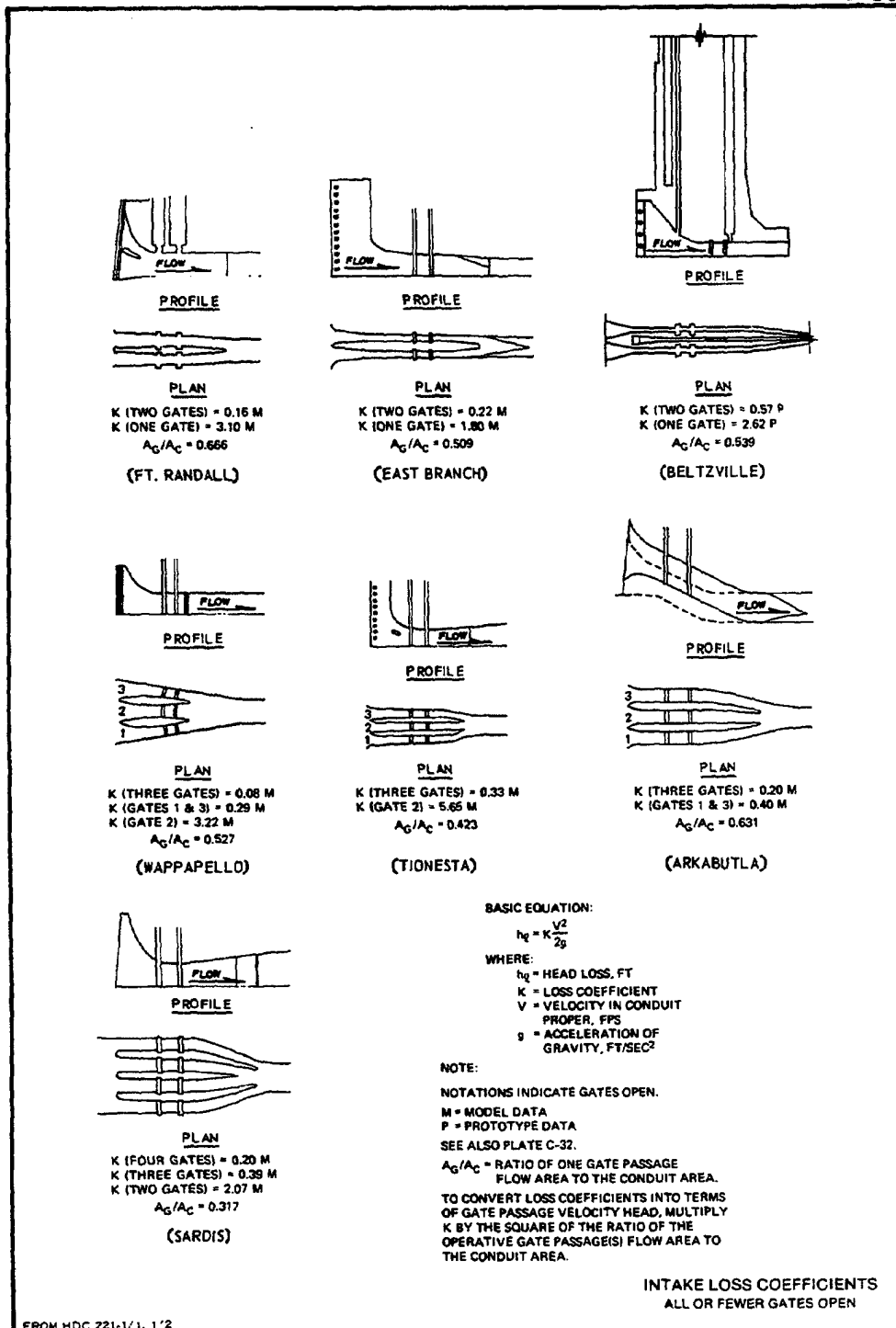

FROM HDC 221-1/1, 1'2

EM 1110-2-1602
 15 Oct 80

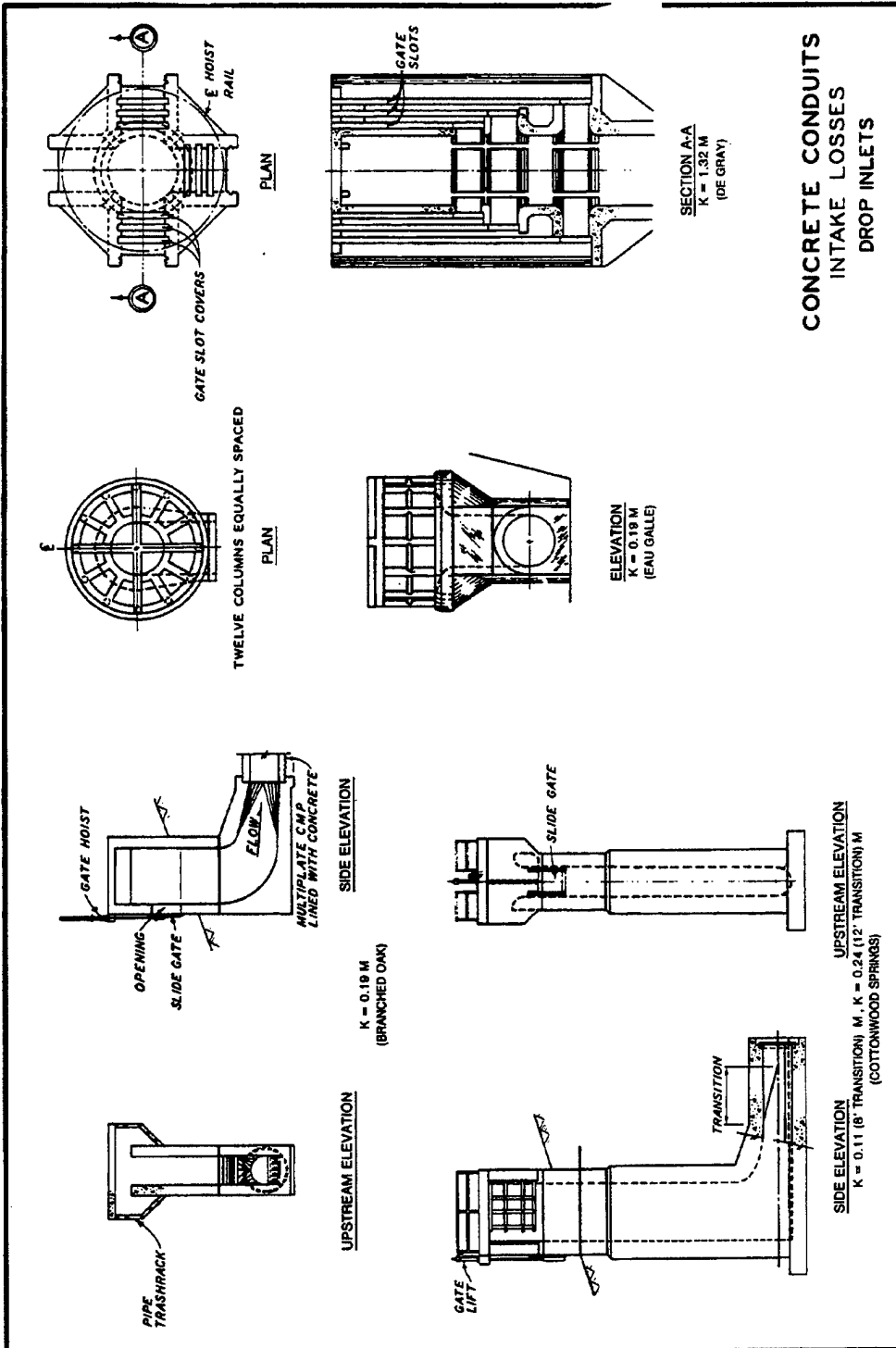

**CONCRETE CONDUITS
 INTAKE LOSSES
 DROP INLETS**

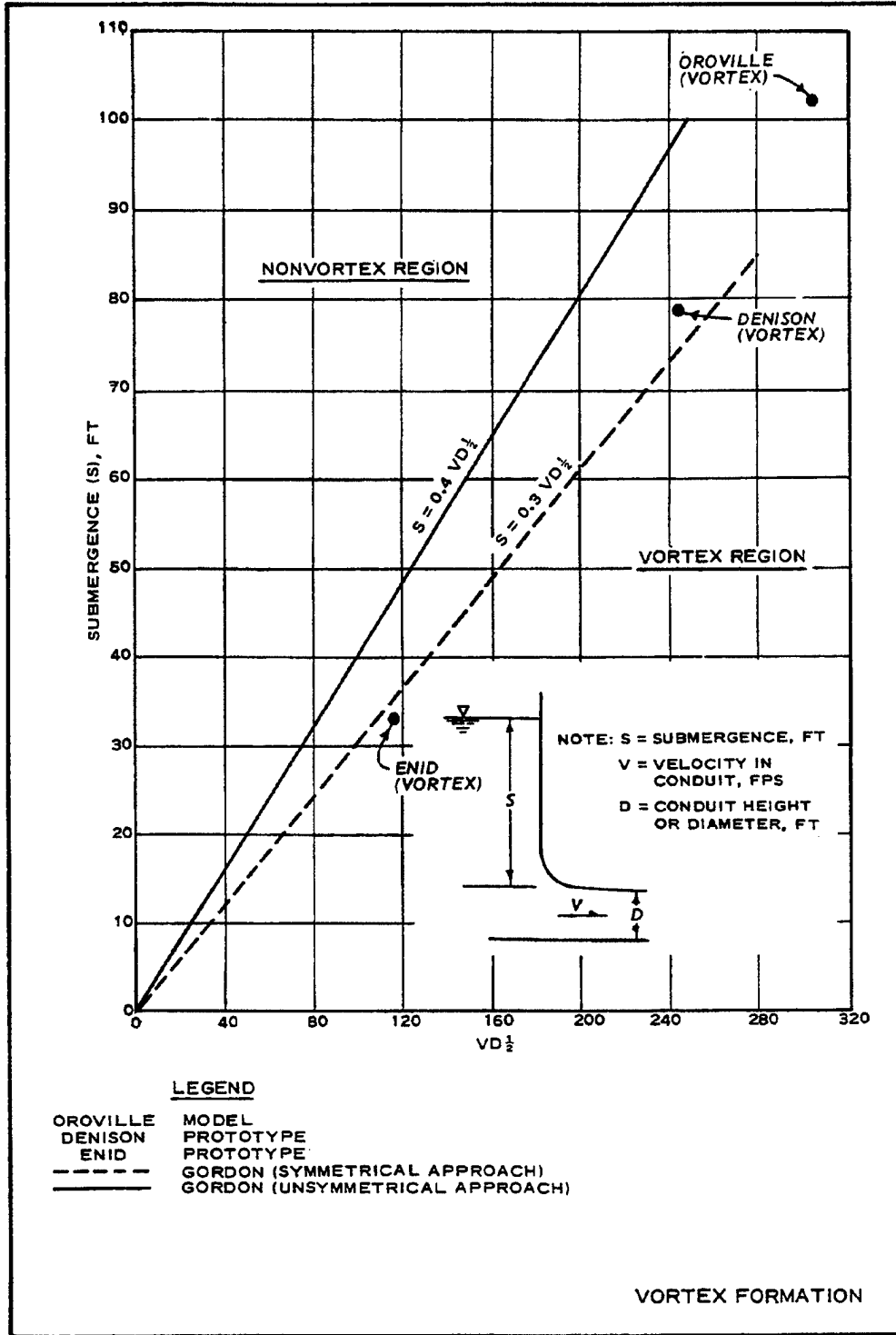

EM 1110-2-1602
15 Oct 80

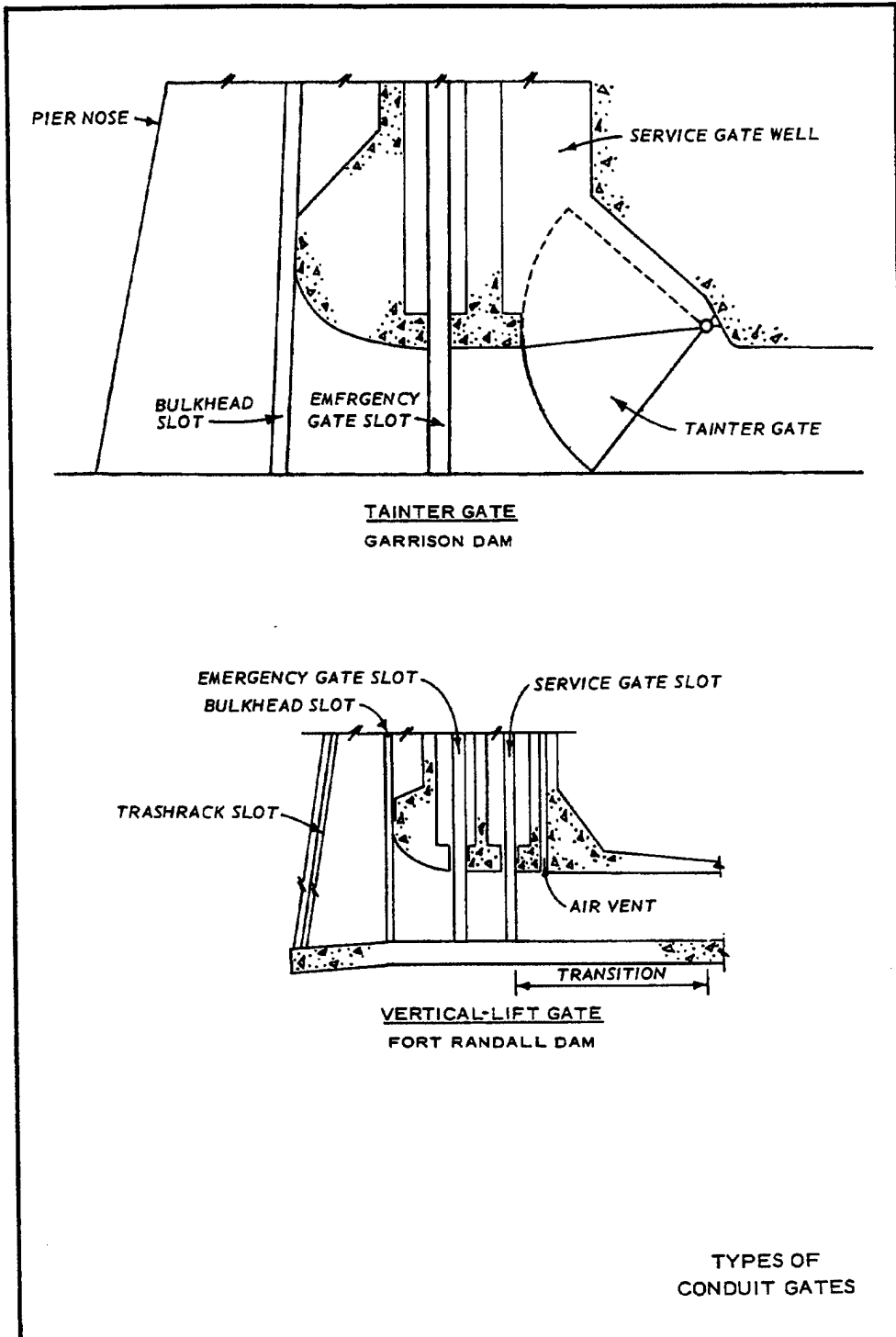

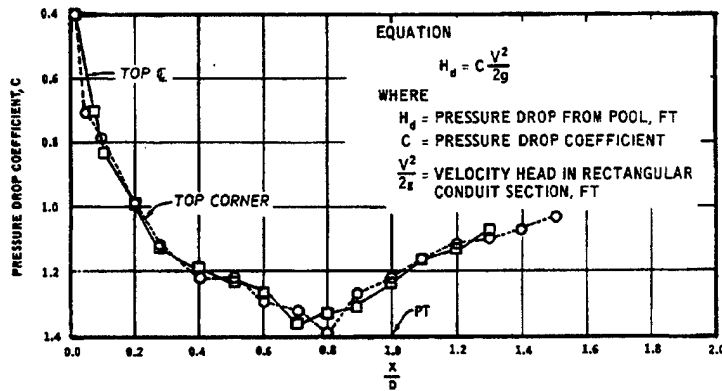

a. "SHORT" CURVE

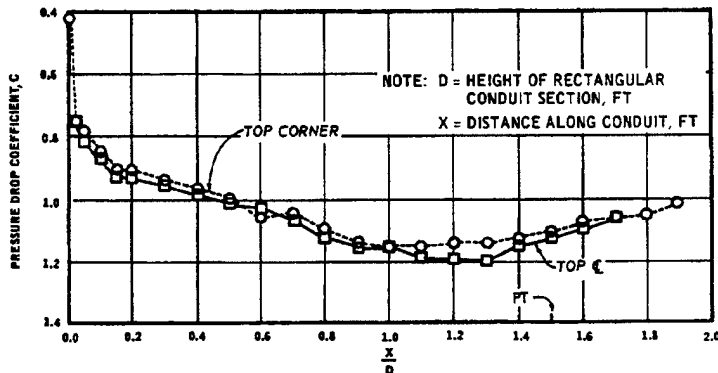

b. "LONG" CURVE

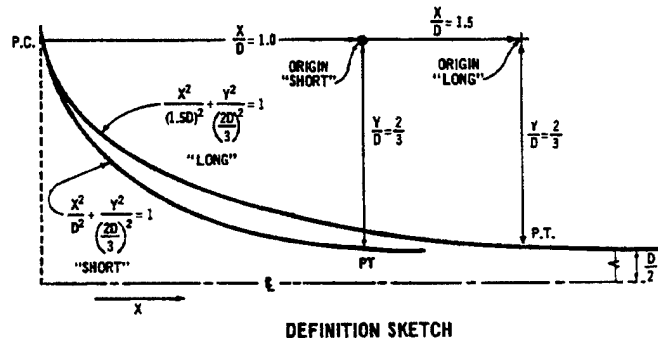

CONDUIT HEIGHT-WIDTH RATIO = 1.785

FROM HDC 221-2, 2/1

PRESSURE DROP COEFFICIENTS
ENTRANCE WITH ROOF CURVE ONLY

EM 1110-2-1602
 15 Oct 80

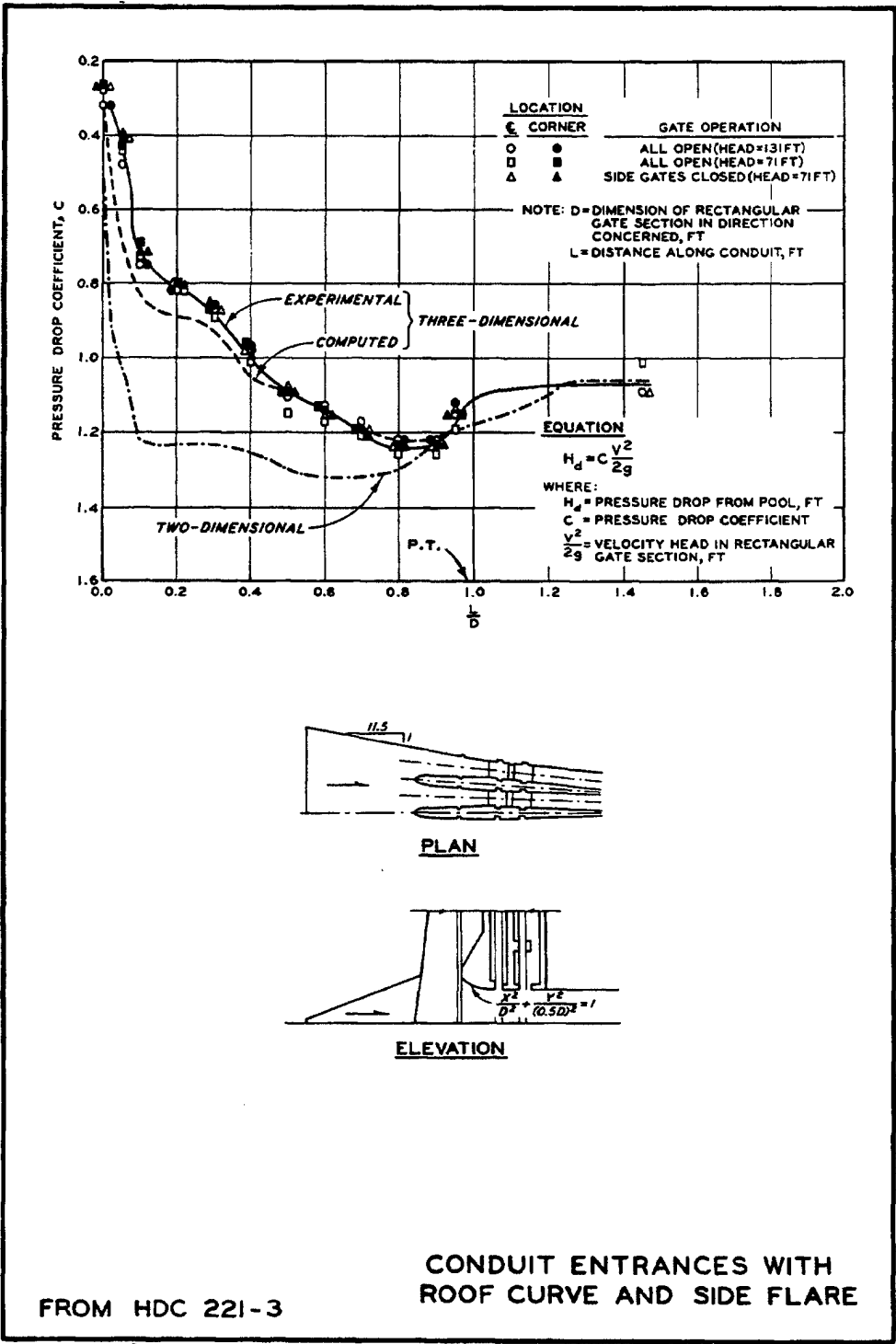

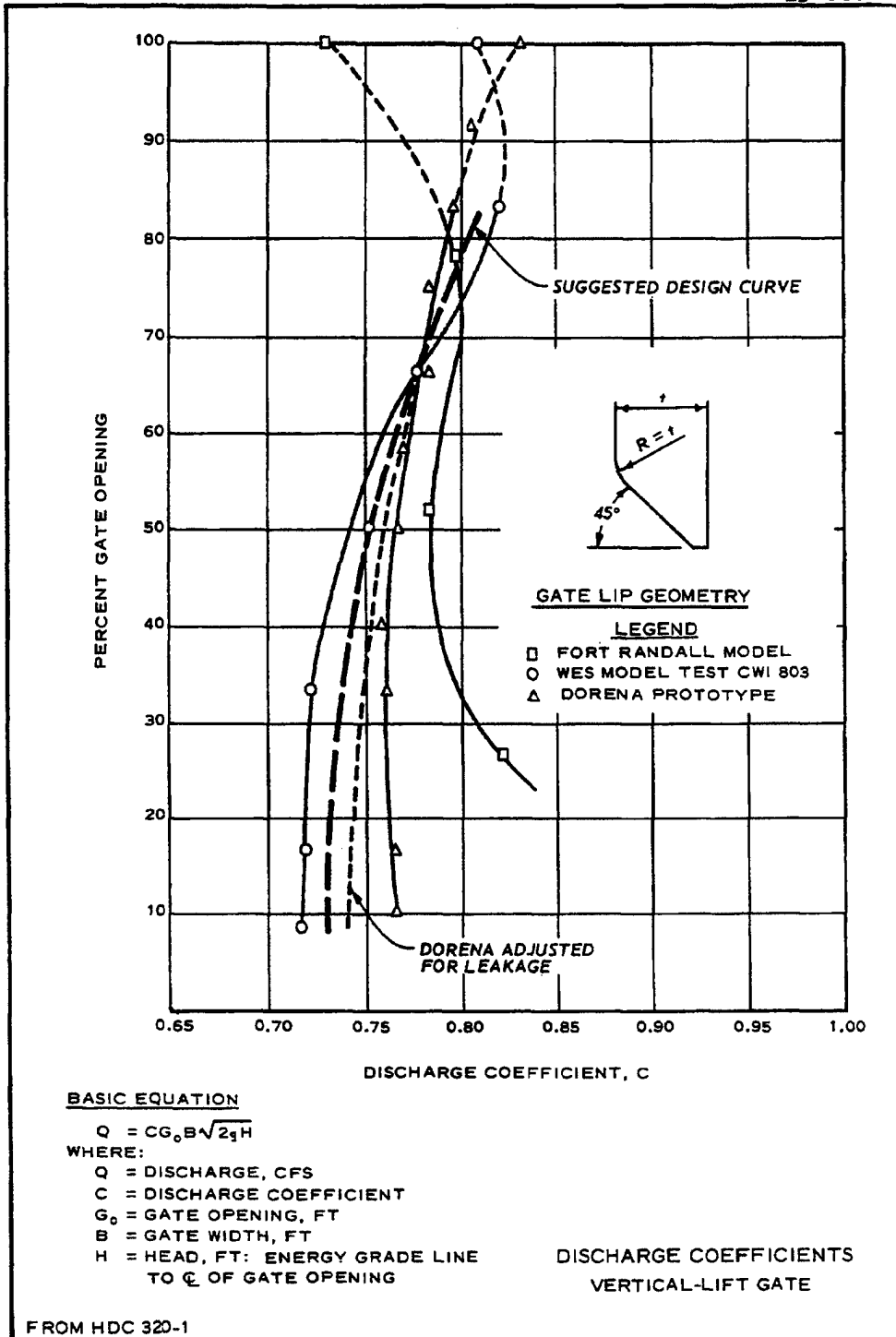

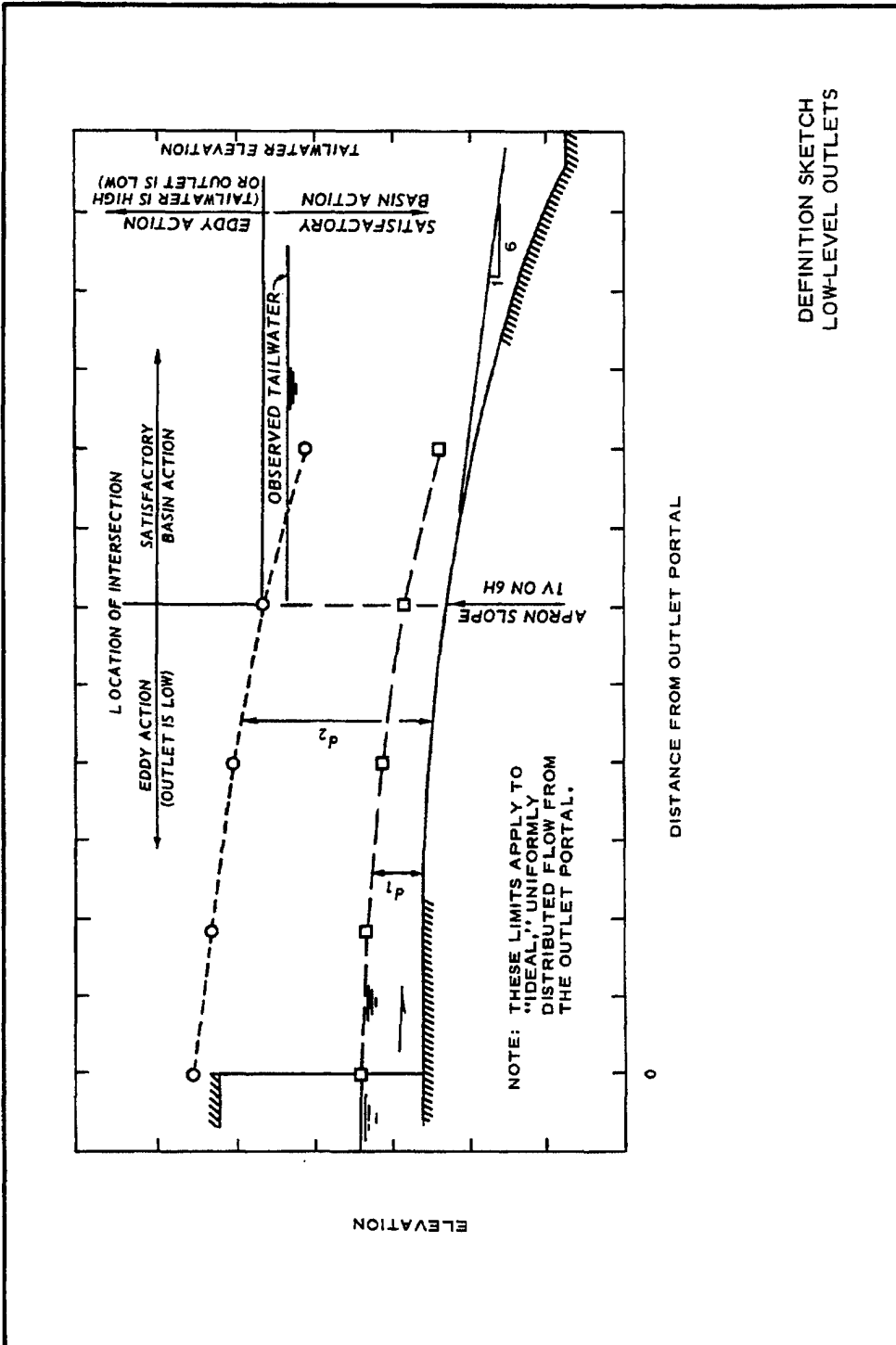

PLATE C-40

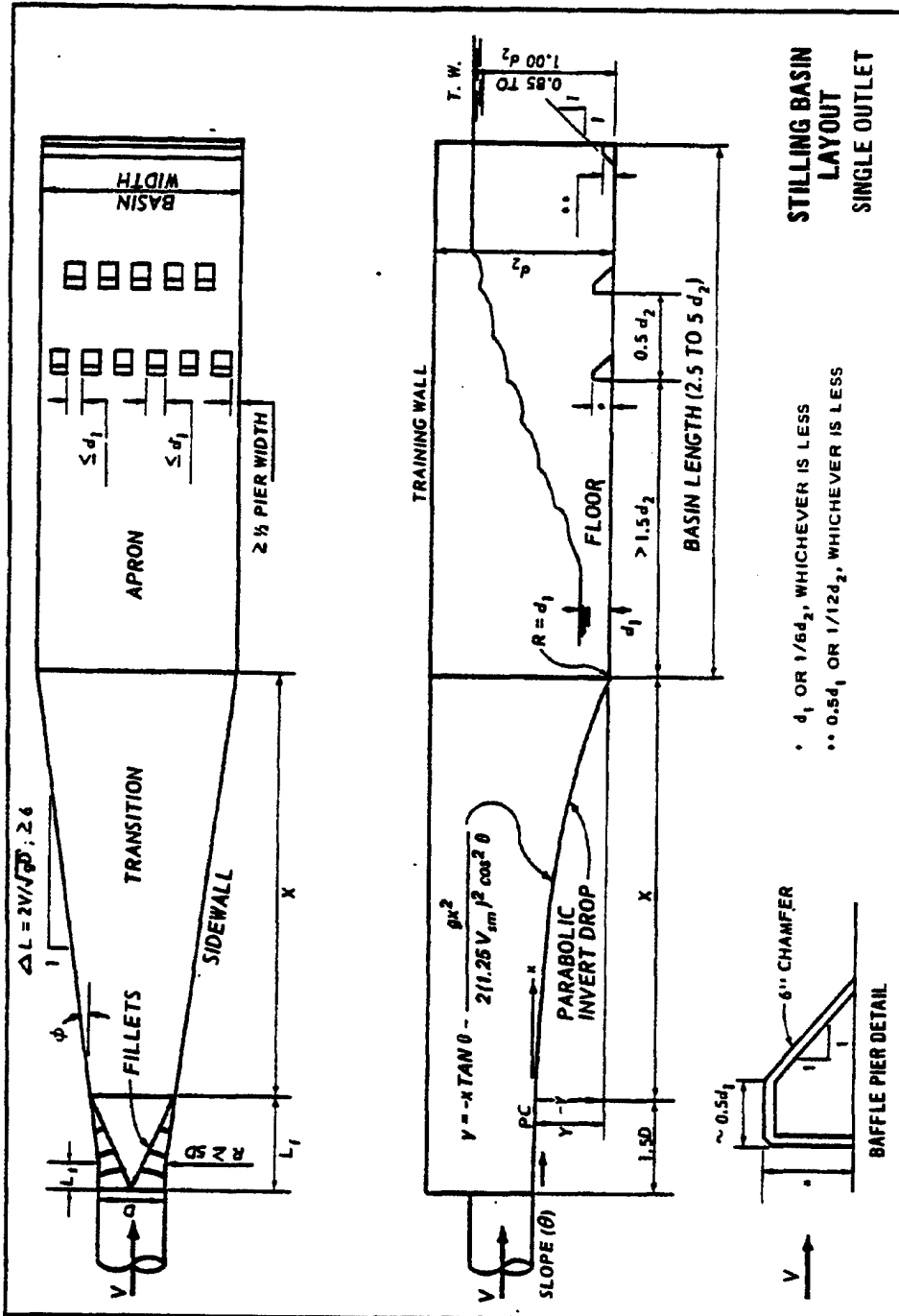
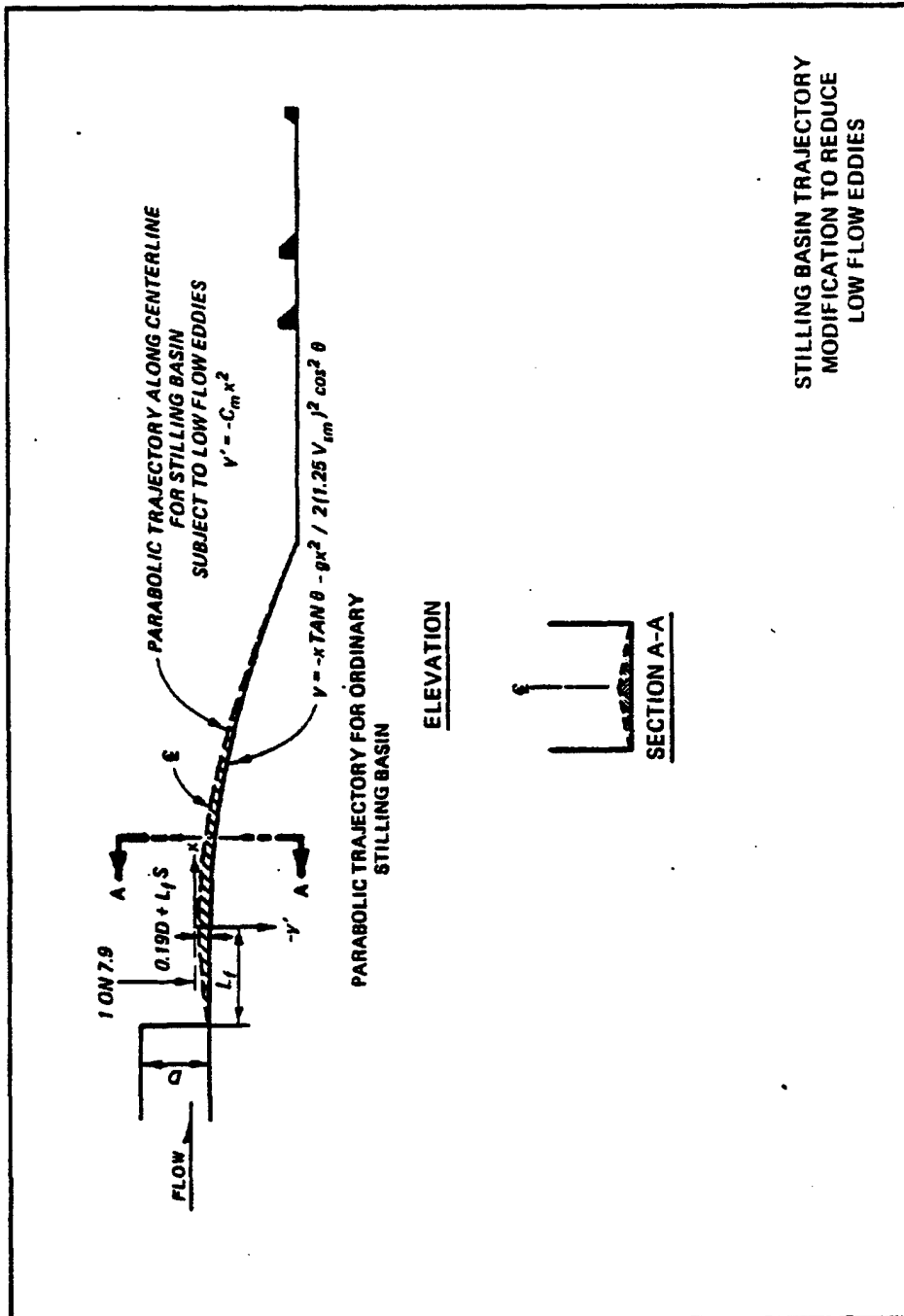

PLATE C-41

EM 1110-2-1602
 Change 1
 15 Mar 87



STILLING BASIN TRAJECTORY
 MODIFICATION TO REDUCE
 LOW FLOW EDDIES

PLATE C-41A

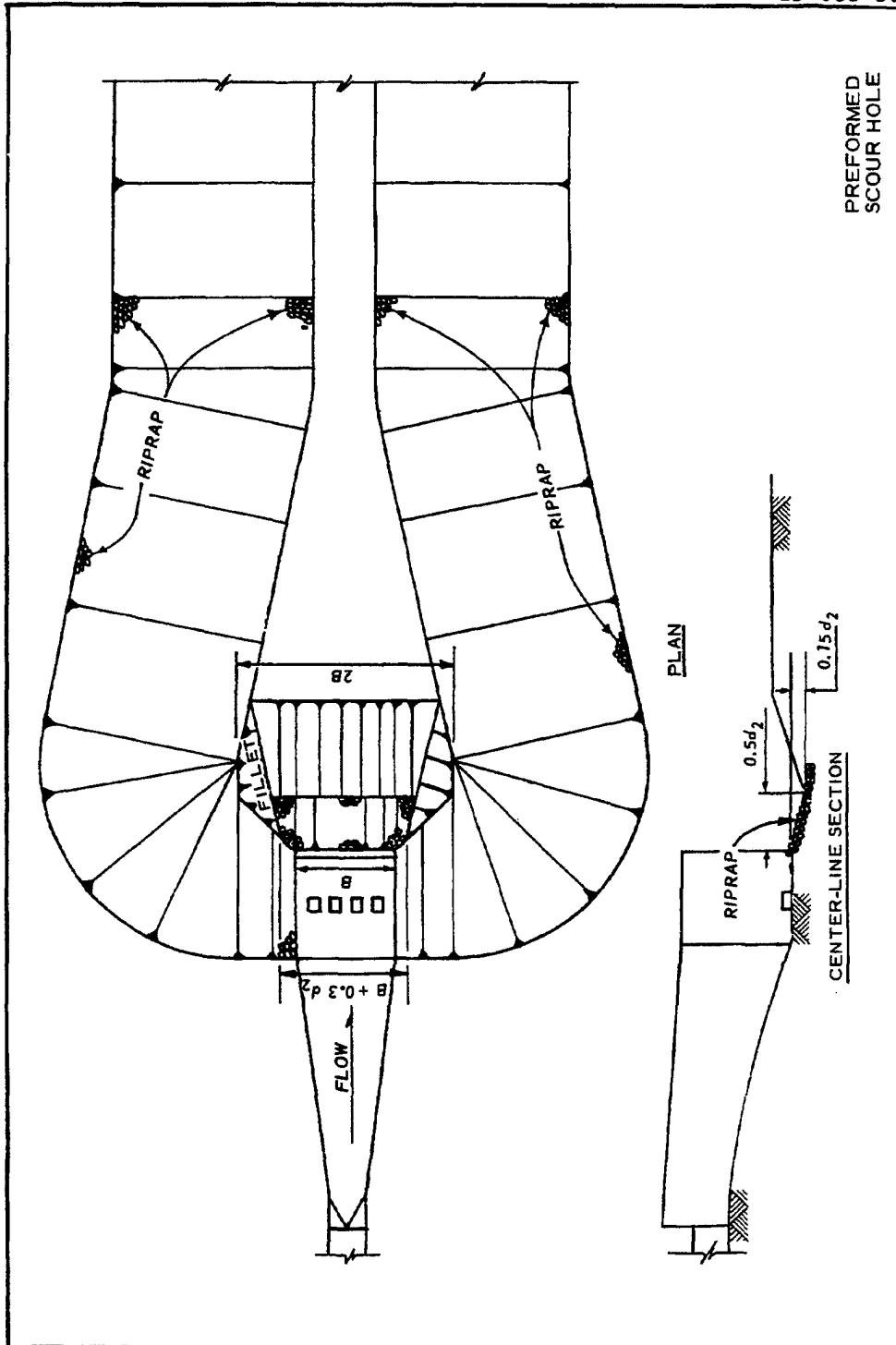

PREFORMED
SCOUR HOLE

EM 1110-2-1602
15 Oct 80

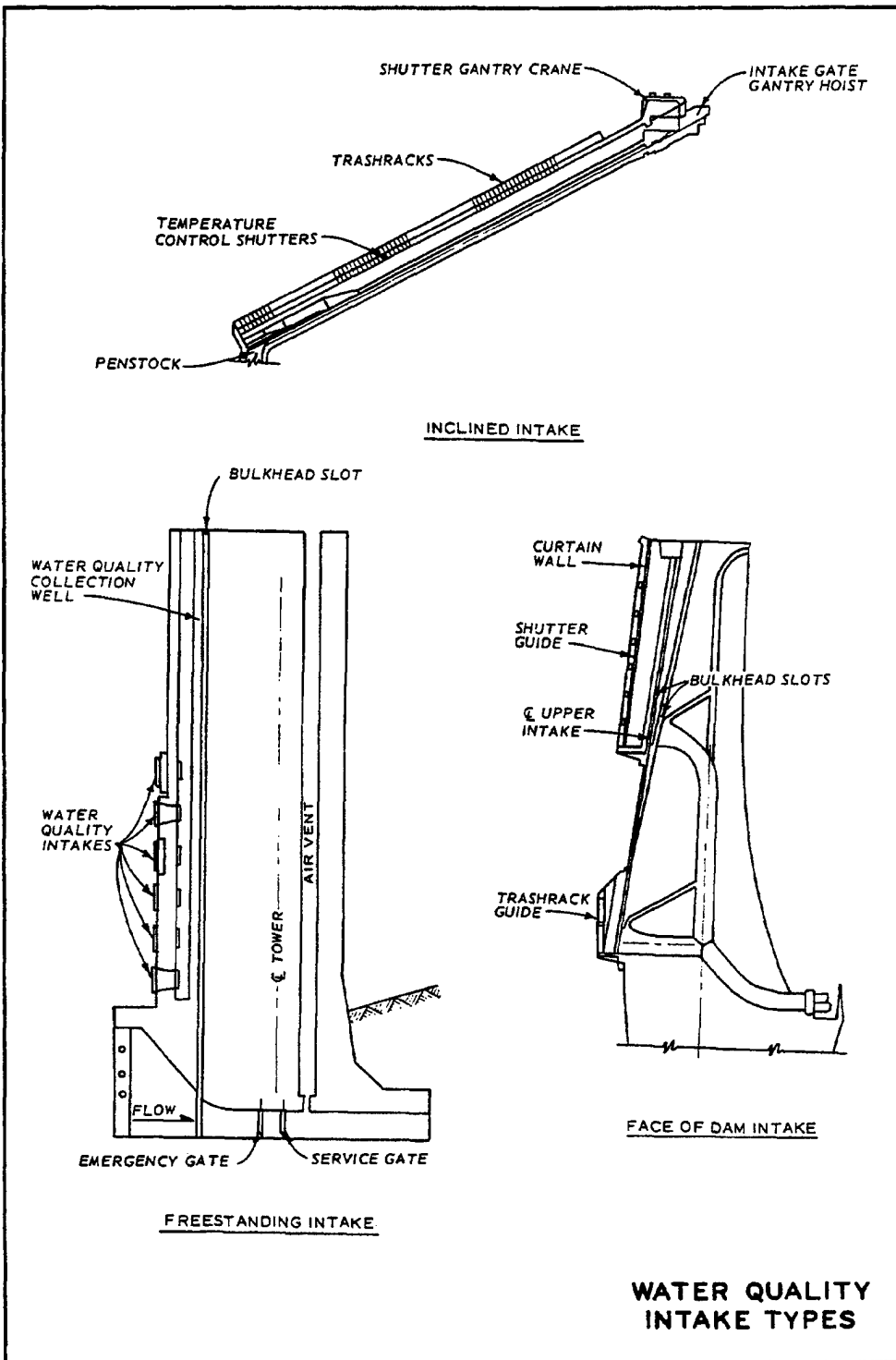

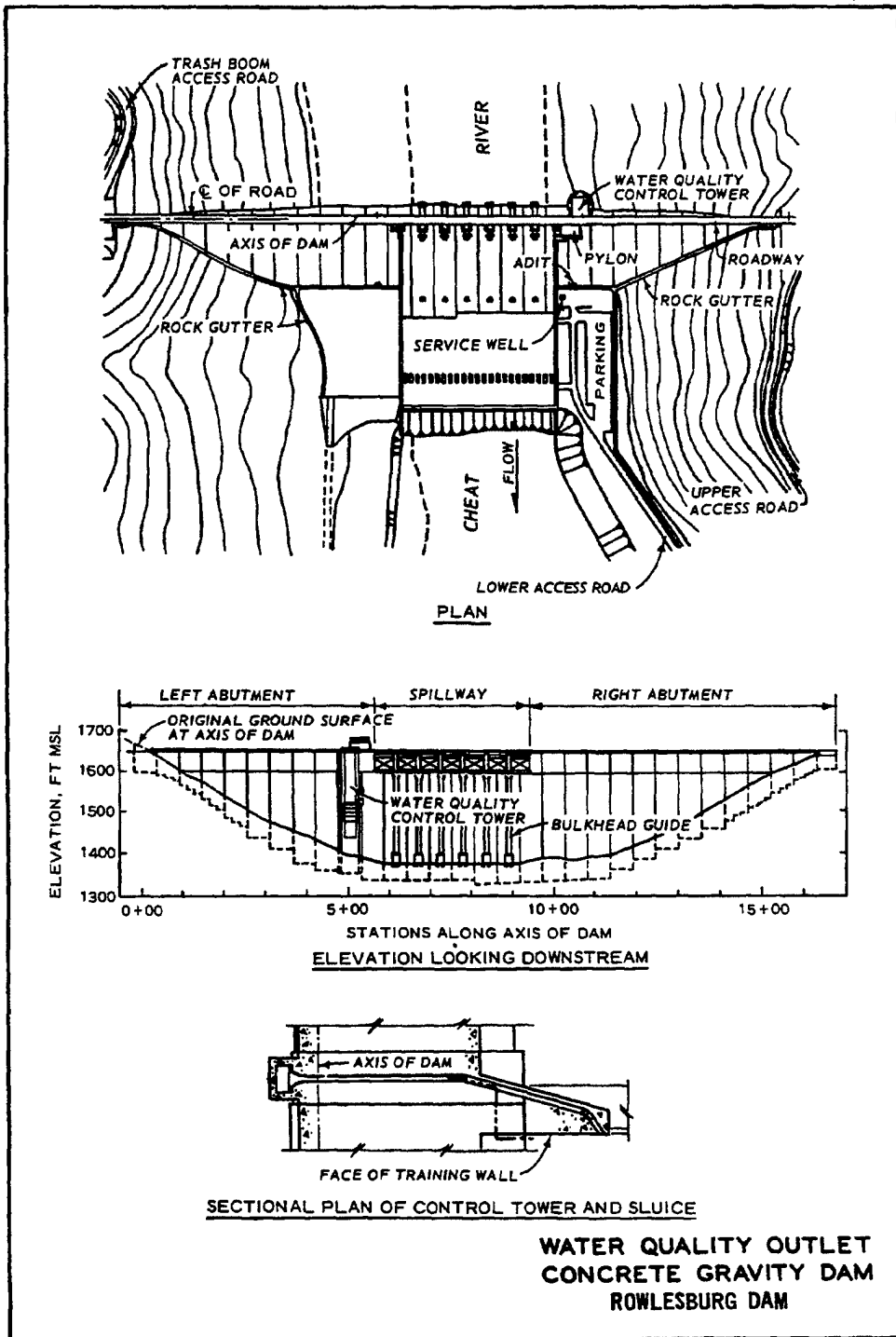

EM 1110-2-1602
 15 Oct 80

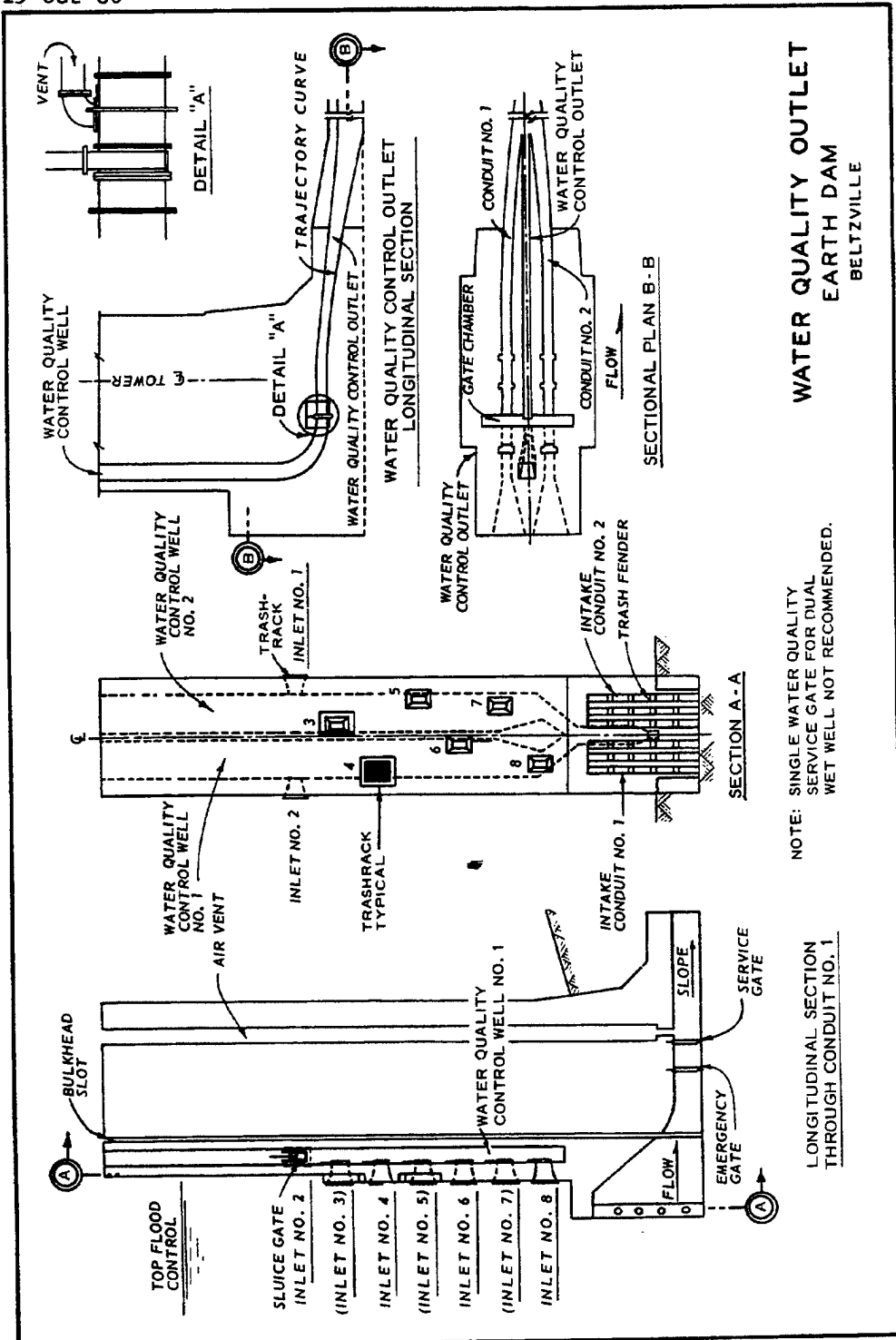

**WATER QUALITY OUTLET
 EARTH DAM
 BELTZVILLE**

NOTE: SINGLE WATER QUALITY SERVICE GATE FOR DUAL WET WELL NOT RECOMMENDED.

LONGITUDINAL SECTION THROUGH CONDUIT NO. 1

PLATE C-46

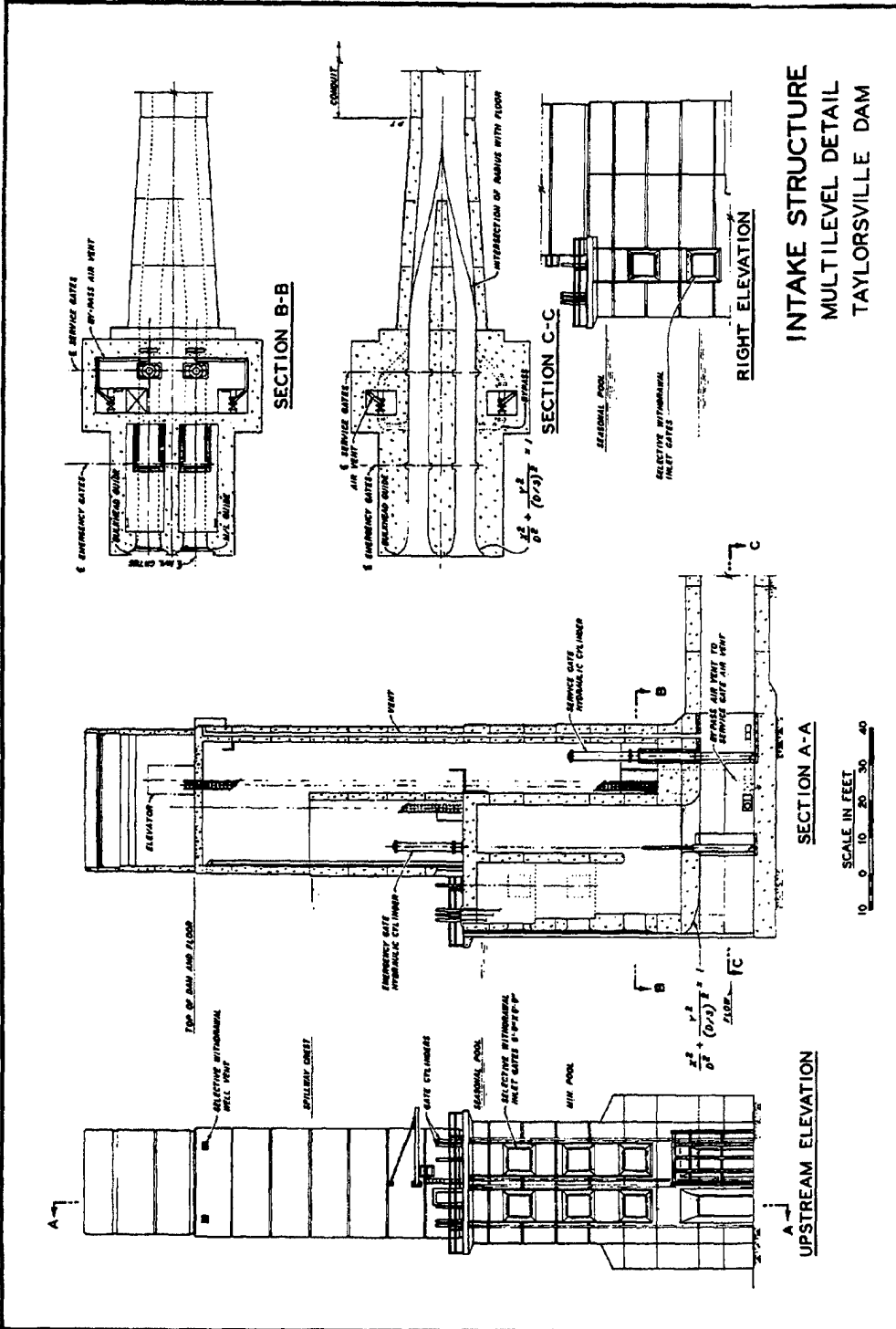

PLATE C-47

EM 1110-2-1602
15 Oct 80

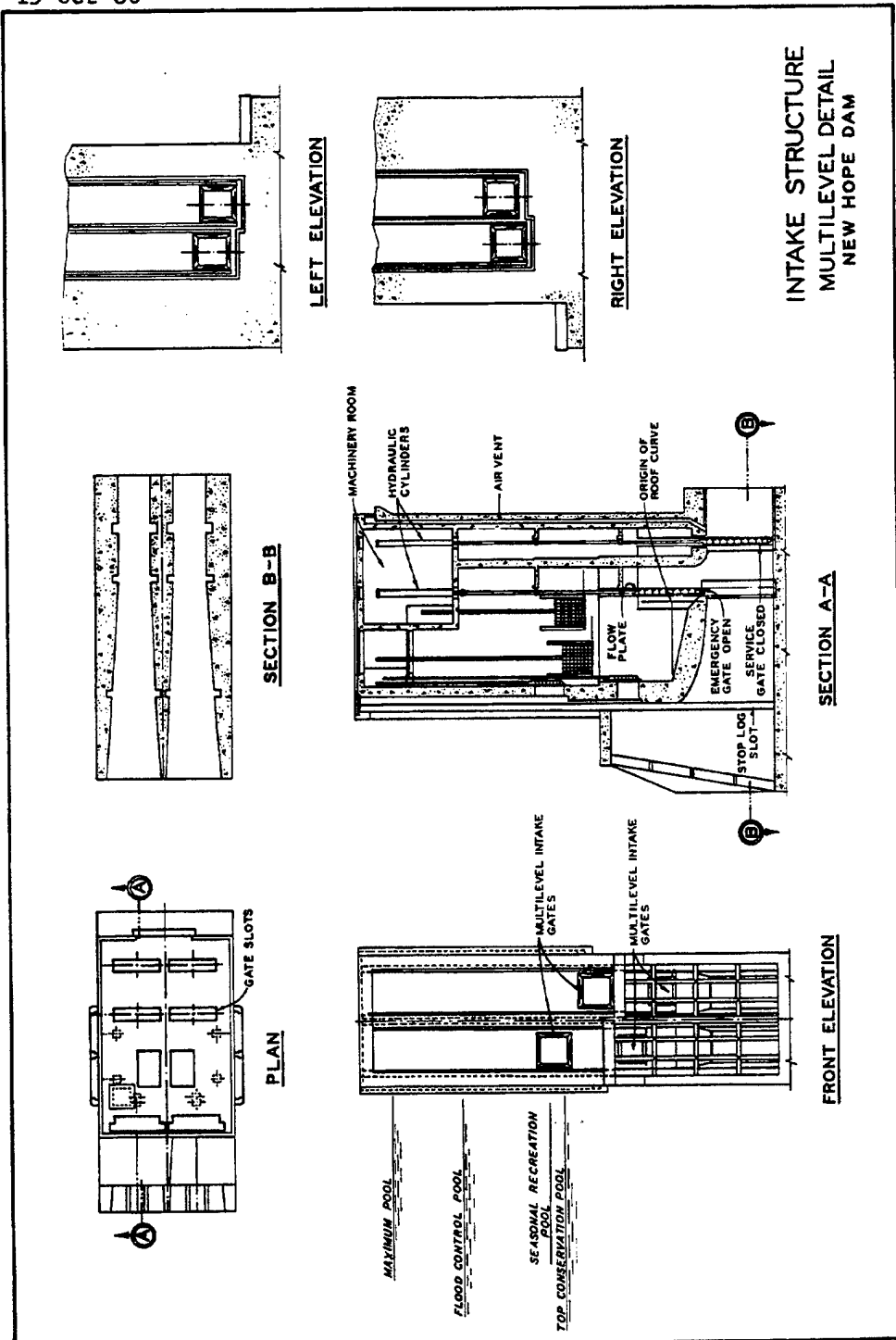
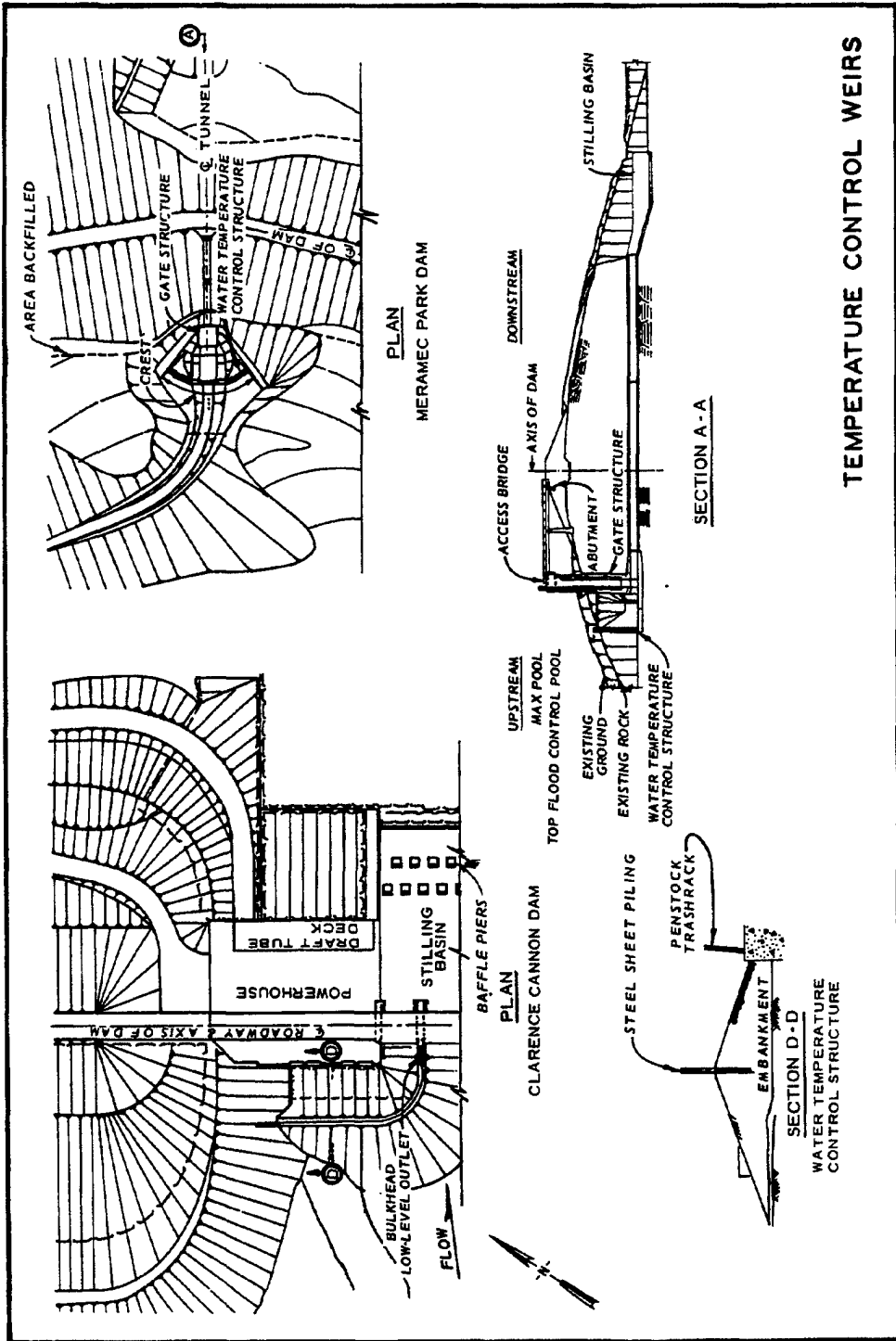

PLATE C-48



TEMPERATURE CONTROL WEIRS

PLATE C-49

EM 1110-2-1602

15 Oct 80

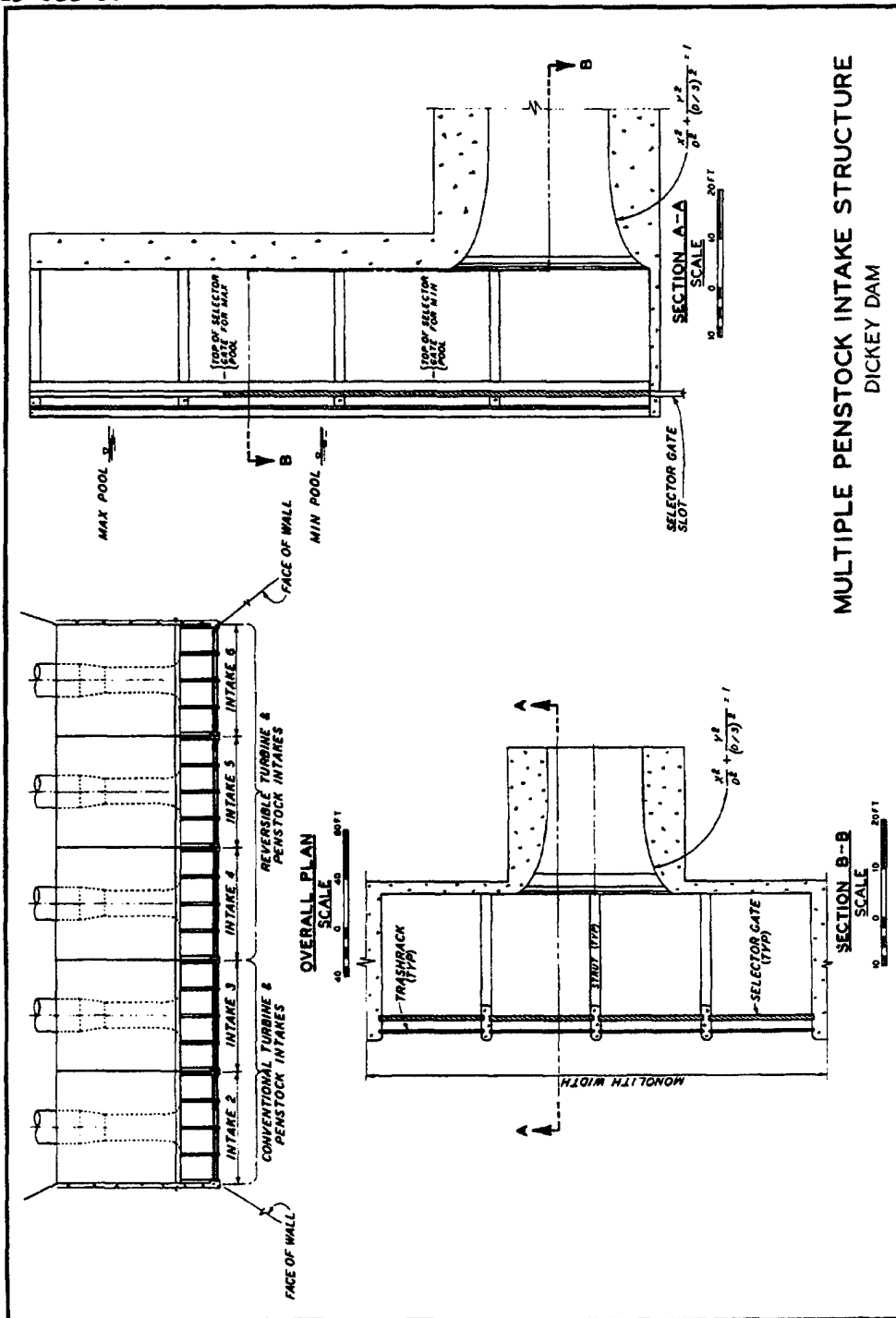
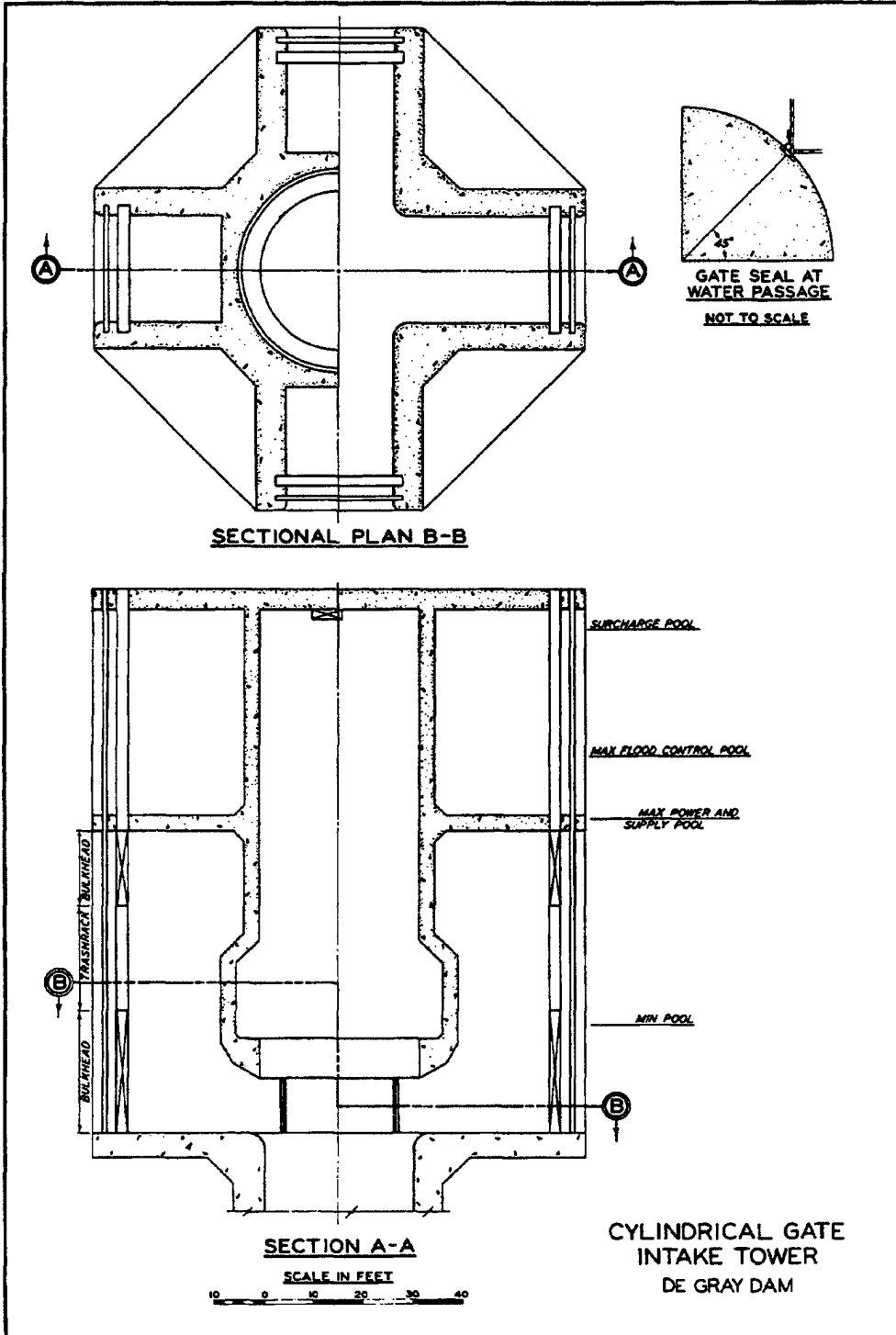

PLATE C-50

EM 1110-2-1602
15 Oct 80



CYLINDRICAL GATE
INTAKE TOWER
DE GRAY DAM

EM 1110-2-1602
15 Oct 80

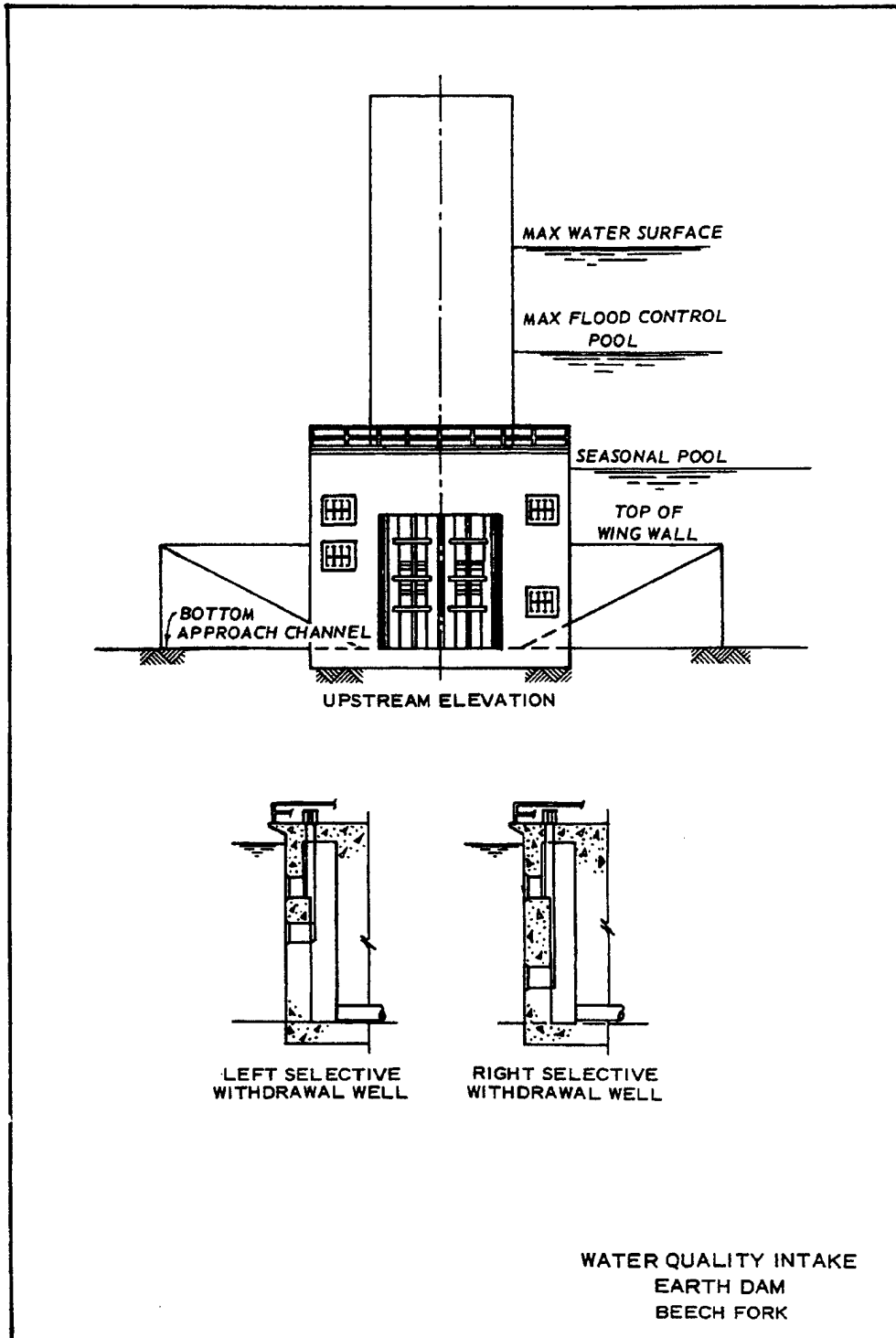

PLATE C-52

APPENDIX D

COMPUTATION OF DISCHARGE RATING CURVES FOR OUTLET WORKS
(Illustrative Example)

D-1. Introduction. The following simplified example is presented to illustrate some of the procedures and guidance given in Chapter 2 and paragraph 4-16 for developing rating curves for outlet works. The procedures are applicable with or without the aid of a programmed computer. A number of comments applying to any conduit discharge computations are included.

D-2. Multiple Conduits. For an outlet works composed of several conduits operating in parallel, the total flow must be proportioned among the conduits before the head-discharge relation can be determined. The division of flow depends upon the nature of the conduit layout; that is, when all the conduits are identical in size, length, shape, and invert elevation and have uniform flow conditions at entrances and exits, the flow will be distributed equally. When the outlet works contain conduits of several sizes which have the same entrance control, the distribution of flow in the conduits is determined by assuming pool elevations and calculating individual conduit discharges. When the conduits are variable in size or the invert elevations are not identical and the discharge control does not occur at the entrance, trial distributions of assumed total discharges must be made; and pool elevations, corresponding to the trial discharges, must be determined for each conduit. The correct flow distribution will be determined when the computed pool elevations are identical for all of the conduits.

D-3. Example Structure. The outlet works selected for this sample computation have two 11- by 22-ft gate passages, a transition section, a 22-ft circular conduit, and a parabolic drop into the stilling basin. A section along the center line of the conduit is shown in plate D-1. Rating curves should be computed for both $k = 0.002$ ft (capacity) and smooth pipe (velocity) conditions for full flow and $k = 0.007$ ft and 0.002 ft, respectively, for partly full flow. This example is limited to the capacity curve computations.

D-4. Computer Programs. A number of computer programs applicable to developing rating curves have been developed and these are available on the computer-aided design system CORPS. The applicable CORPS program name(s) will be noted throughout this example problem. It is recommended that the designer periodically check the list of available programs in CORPS to determine if additional programs have been added to the system.

He should also check with the WES Engineer Computer Program Library to see if programs are available outside of the CORPS system.

D-5. Discharge Controls. The computation of flow through a conduit usually involves consideration of several conditions of flow. During diversion when the upper pool is at low stages or at lower partial gate openings at any stage, open-channel flow may occur in the conduit. As the reservoir level is raised or the gate opening is increased, the depth of flow in the conduit increases until the conduit flows full. Determinations are needed of whether there is inlet control, outlet control, critical depth control, or gate control and when the control shifts from one type to another. Definition of the discharge curves requires open-channel, pressure flow, and gate discharge computations. The open-channel flow computations probably will require flow profiles to evaluate energy losses and establish the limits of the open-channel flow ranges for both diversion and gated flow conditions.

D-6. Hydraulic Characteristic Curves. Prior to determining conditions of open-channel flow and type of control and computing the rating curves, the following hydraulic characteristic curves should be prepared:

a. Tailwater stage-discharge curves for several conditions of any anticipated downstream channel degradation or aggradation (see para 1-10b(4)(a)).

b. Conduit cross-sectional areas of flow in square feet plotted as abscissas against flow depths in feet plotted as ordinates. (CORPS H6002, H2040, H2041, H2042,^o or King's Handbook (item D-4) Table 7-4.)

c. Conduit hydraulic radii of flow section in feet as abscissas against flow depths in feet as ordinates. (CORPS H6002, H2040, H2041, H2042,^o or King's Handbook (item D-4) Tables 7-1 or 7-5.)

d. Conduit discharges in cubic feet per second as abscissas against the corresponding critical depths in feet as ordinates. (CORPS H6140, H6141,^o or King's Handbook (item D-4) Tables 8-4, 8-5, 8-9, or 8-10.)

e. Conduit discharges in cubic feet per second as abscissas against the corresponding normal depths in feet as ordinates. (CORPS H6113 to H6118.^o)

If manual computations are used, the conduit characteristic curves should be plotted to a sufficiently large scale so that areas may be read to the nearest square foot and hydraulic radius to the nearest 0.01 ft. Approximate characteristic curves for the 22-ft circular

conduit are shown in plate D-1. The discharge curves indicate that when open-channel flow occurs in the conduits, normal depth is greater than critical depth for each discharge, and a practical maximum depth is about 18 ft. Therefore, critical depth discharge control will occur at the outlet (sta 10+70). If the tailwater causes the flow to be at greater than critical depth at the outlet, there will then be less discharge for a given pool elevation. Backwater computations are required to determine the water-surface elevation at the intake. Also, they may be required at selected discharges extending over the full range of open-channel flow to determine whether and how much the tailwater influences open-channel discharge in the conduits.

D-7. Discharge Curves. The computed discharge curves (capacity) for the 22-ft circular conduit are shown in plate D-2. Computations of the various parts of the curves for the different flow conditions are explained in the following paragraphs. The transitions from partly full to full or pressure flow and vice versa cannot be computed with present theory and must be estimated by judgment. The shaded areas on the curve represent these regions in which head-discharge relations may be unstable, subject to a rising or falling pool. On a rising pool (with gates fully open) it was assumed that open-channel flow conditions existed until the flow depth in the intake was equal to approximately 90 percent of the conduit diameter, after which flow conditions shifted rapidly to less efficient, full conduit flow at a lower discharge. On a falling pool it was assumed that pressure flow existed until the pool elevation dropped a few feet below the shift elevation for a rising pool, in this case to the intake crown level. Actual prototype behavior of a conduit with similar geometry would be helpful but such information is generally lacking. Model studies may be helpful in some cases where operation in the unstable range is necessary.

D-8. Open-Channel Discharge. Flow control will occur at sta 10+70 for all open-channel discharges (without gate control). In this case, the head-discharge relation for open-channel flow is determined from the curve of discharge at critical depth (see para D-6d above and plate D-1), backwater curve computations to sta 2+00, and intake losses upstream of sta 2+00. Typical computations are summarized in table D-1 and plotted as curve A in plate D-2. Backwater curve computations are described in paragraphs D-11 and D-12.

D-9. Pressure Flow. Discharge for a conduit flowing full is determined by equations and computations for conduit losses and discharges given in table D-2 and plotted as curve B in plate D-2.

Table D-1

Summary of Example Computations for Head-Discharge Curve
Open-Channel Flow, Critical Depth Control at Outlet
(Capacity Flow)

D = 22 ft; S = 0.00115; k = 0.007 ft; L = 870 ft; $\nu = 1.21 \times 10^{-5}$
ft²/sec at 60°F; $K_e = 0.38$; $K_v = 1.00$

See plate D-1 for y_c (critical depth), y_o (normal depth), R (hydraulic radius) and Area

See table D-3 for example manual computations of water-surface profile, or use CORPS H6208.

For a given Q:

Pool elevation = conduit invert elevation (1229) + y + $(K_e + K_v) \frac{V^2}{2g}$,
all segments at sta 2+00.

Sta 10+70			0.99 y_o	Sta 2+00			1.38 $\frac{V^2}{2g}$	Pool El
Q	y_c	y_o		Sta	y*	V		
cfs	ft	ft	ft	ft	fps	ft	ft	ft msl
250	2.98	3.67	2+50*	3.67	6.00	0.56	0.77	1,233.4
500	4.24	5.21	††	5.11	7.45	0.86	1.19	1,235.3
1,000	6.04	7.49	††	7.26	9.14	1.30	1.79	1,238.0
2,000	8.65	11.10	††	10.41	11.29	1.98	2.73	1,242.1
3,000	10.69	14.45	††	12.96	12.89	2.58	3.56	1,245.5
3,900	12.26	18.05	††	15.01	14.11	3.09	4.26	1,248.3

Conduit flows full at 3940 cfs

* Values obtained with CORPS H6208.

† Coefficient for open-channel flow intake loss upstream from sta 2+00 assumed to be 50% larger than pressure flow coefficient of 0.25 from plate C-32.

†† 0.99 y_o would occur upstream from sta 2+00 if conduit section was extended upstream.

Table D-2
Example Head-Discharge Computations for Conduit Flowing Full
Pressure Flow (Capacity)

$D = 22 \text{ ft}$ $A = 380 \text{ ft}^2$ $T = 60^\circ\text{F}$ $v = 1.21 \times 10^{-5} \text{ ft}^2/\text{sec}$ $L = 870 \text{ ft}$
 $k = 0.0020 \text{ ft}$ $\frac{D}{k} = 11,000$ $IR = \frac{VD}{v}$ $IF = \frac{V}{\sqrt{gD}}$ $K_f = f \frac{L}{D}$
 (for capacity)

For a given discharge:
 Pool elevation = Exit portal invert elevation (1228.0) + y_p + H
 where $H = K \frac{v^2}{2g}$ and $K = K_e + K_f + K_v$

Q	v	$v^2/2g$	IF†	y_p/D ††	y_p	$IR/10^7$	f ‡	K_f	K_e ‡‡	K_v	K	H	Pool Elevation
cfs	fps	ft			ft		ft					ft	ft msl
5,000	13.15	2.7	0.5	1.00	22.0	2.37	0.0118	0.47	0.25	1.00	1.72	4.6	1,254.6
10,000	26.3	10.7	1.0	0.82	18.0	4.74	0.0118	0.47	0.25	1.00	1.72	18.4	1,264.4
15,000	39.5	24.2	1.5	0.72	15.8	7.12	0.0118	0.47	0.25	1.00	1.72	41.6	1,285.4
20,000	52.6	43.0	2.0	0.67	14.7	9.48	0.0118	0.47	0.25	1.00	1.72	74.0	1,316.7
25,000	65.8	67.2	2.5	0.63	13.9	11.9	0.0118	0.47	0.25	1.00	1.72	115.6	1,357.5
30,000	78.9	96.7	3.0	0.61	13.4	14.2	0.0118	0.47	0.25	1.00	1.72	116.3	1,407.7

† Froude number.
 †† Pressure gradient at exit portal from plate C-3 (extrapolated for $IF = 0.5$).
 ‡ Darcy-Weisbach resistance coefficient from plate C-4. (In computing conduit discharge and flow velocity for energy dissipator, use smooth pipe curve.)
 †† Intake loss coefficient for double intake (similar to Fort Randall prototype) from plate C-32.

D-10. Gate-Controlled Discharge. The head-discharge relation for partial gate openings with free-surface flow downstream (see para 4-16 and CORPS H3201^o) is modified to include intake losses upstream of the gates. Typical computations are given in table D-3 and plotted as curve C in plate D-2. If pressure flow occurs downstream from the gates, the head-discharge relation can be computed as in paragraph D-9 above with an added loss coefficient for the partly open gates. This loss coefficient can be determined from the gate flow contraction coefficient (plate C-39), an abrupt expansion loss coefficient (plate C-8), and a conversion to the appropriate reference section (as noted in para 2-13(a)). Local pressures just downstream from the gate should then be checked by subtracting the contracted jet velocity head from the pressure grade line just upstream from the gate. If the local pressure is subatmospheric, air will be drawn through the vents. (See para 3-17 in main text.) This will reduce the effective head through the gate and produce aerated flow in the conduit downstream from the gate, both factors severely complicating calculation of a head-discharge relation in this flow condition. Slug flow also may occur in this range of unstable flow (see para D-13 below).

D-11. Profile Analysis. The open-channel flow computations generally involve flow profile calculations. A qualitative profile analysis should precede computations in order to predict the general shape of the possible flow profiles that may occur in a conduit system. See paragraph 2-3, plate C-1, and Chow (item D-2, Chapter 9) for more information and procedures. Typical profiles in an outlet works conduit might include:

- a. M2 upstream and S2 downstream from a point of critical depth control.
- b. M1, M2, C1, or S1 upstream from conduit outlet, depending on stilling basin apron slope and tailwater elevation.
- c. H3, M3, C3, or S3 downstream from a partly open gate.

Rapidly varied profiles may occur in the intake and transition, at the outlet, at any hydraulic jump, at changes in cross section and alignment, and past obstacles. Except for a few relatively simple boundary configurations, these conditions are very difficult to compute accurately and will require experimental evaluation. In this example M2 curves occur upstream of the outlet for low flows and M3 curves occur downstream of the gate at partial openings.

D-12. Flow Profiles Through Conduits. Most of any needed computations can be done with CORPS H6208 and H6209^o for straight, uniform-section

Table D-3
Head-Discharge Computations for Partly Open Gates
Open-Channel Flow Downstream

$$Q = B C_c G_o P \sqrt{2g(H-E-C_c G_o)}$$

B = gate passage width = 11 ft
P = number of gate passages = 2
g = gravitational acceleration = 32.2 ft/sec²
E = gate passage invert elevation = 1229 ft msl
C_c = contraction coefficient (plate C-39)
G_o = gate opening, ft
H = energy grade line elevation at gate, ft msl

$$Q = 22 C_c G_o \sqrt{64.4 (H-1229-C_c G_o)}$$

$$\text{Pool El} = H + K_e \frac{V_p^2}{2g}$$

K_e = Intake loss coefficient = 0.16 (plate C-32)
(short, streamlined entrance upstream from gate assumed similar to sluice intake, or about half of full loss for this type of tunnel intake).

$$V_p = \text{average velocity in gate passage upstream from gate} = Q/(2 \times 11 \times 22) = Q/484 \text{ fps}$$

Gate Opening G _o , ft	Contr Coeff C _c	EGL El H, msl	Disch Q cfs	V _p fps	K _e V _p ² /2g ft	Pool El H+K _e V _p ² /2g
5.50	0.734	1,250.00	2,935	6.07	0.09	1,250.09
		1,260.00	3,701	7.65	0.15	1,260.15
		1,280.00	4,884	10.10	0.25	1,280.25
		1,300.00	5,835	12.06	0.36	1,300.36
		1,320.00	6,649	13.74	0.47	1,320.49
		1,340.00	7,374	15.24	0.58	1,340.58
		1,360.00	8,034	16.60	0.68	1,360.68
		1,380.00	8,644	17.86	0.79	1,380.79
11.00	0.752	1,250.00	5,215	10.77	0.29	1,250.29
		1,260.00	6,969	14.40	0.51	1,260.51
		1,280.00	9,555	19.74	0.97	1,280.97
		1,300.00	11,578	23.92	1.42	1,301.42
		1,320.00	13,296	27.47	1.88	1,321.88
		1,340.00	14,816	30.61	2.33	1,342.33
		1,360.00	16,194	33.46	2.78	1,362.78
		1,380.00	17,464	36.08	3.23	1,383.23
16.50	0.793	1,250.00	6,503	13.44	0.45	1,250.45
		1,260.00	9,782	20.21	1.01	1,261.01
		1,280.00	14,229	29.40	2.15	1,282.15
		1,300.00	17,585	36.33	3.28	1,303.28
		1,320.00	20,397	42.14	4.41	1,324.41
		1,340.00	22,865	47.24	5.54	1,345.54
		1,360.00	25,091	51.84	6.68	1,366.68
		1,380.00	27,136	56.07	7.81	1,387.81

conduits flowing partly full. Although the Manning n coefficient has been extensively used for free-surface flow, use of the Darcy f or Chezy C relates losses to the Reynolds number of the flow as well as to a physical estimate of the equivalent boundary surface roughness k . The relations between the coefficients C , f , and n can be expressed as $C/1.486 = 10.8/f^{1/2} = R^{1/6}/n$, where R is the hydraulic radius of the flow boundary. The basic theory is given in Chapter 2 of the main text. Application of the theory to free-surface flow is covered in paragraphs 7 and 8 of EM 1110-2-1601.^h A sample computation using k and C in a nonprismatic channel is given in plate 9 of EM 1110-2-1601.^h Equivalent roughness heights k of 0.007 ft for capacity and 0.002 ft for velocities are recommended for concrete conduits in accordance with the guidance given in EM 1110-2-1601.^h Although it is sometimes assumed that free-surface flow is hydraulically rough flow in large concrete conduits, the example given in table D-4 for a surface profile upstream from the outlet is applicable to smooth surface and transition zone flows. An enlarged portion of the open-channel flow resistance coefficients diagram from HDC 631ⁿ (similar to Moody diagram in plate C-4) is given in plate D-3 for computational convenience.

D-13. Slug Flow. Slug flow occurs when the discharge and energy level are almost sufficient to cause the conduit to flow full. It will occur in any conduit that is operated at a given pool level with discharges that will produce either full or partly full flow conditions. It is most often encountered in long, small diameter conduits. In this flow transition zone, between partly full and full flow, large air bubbles (the slugs) are trapped by the flow and are separated by sections of full flow in the conduit. Although these slugs can move in an upstream direction in conduits with steep slopes, or low velocities (see plate D-4 and item D-3), they most commonly move downstream in an outlet conduit. Neither the air bubbles nor the water sections will cause any impact on the conduit proper; but they may impact on appurtenances at the ends of a conduit. Should the slugs move upstream they can cause adverse gate vibrations and possible air vent damages, or if the conduit does not have gates, trashrack vibration problems. In the more common case with the slugs moving downstream, the impact is wave action through the energy dissipator and the downstream channel. Because these impacts are usually very adverse, the designer should try to obtain a design such that the range of troublesome discharges is sufficiently narrow to permit it to be quickly passed through without changing the downstream water levels and/or velocities too rapidly, or a design such that slug flow conditions will occur only under unusual and infrequent operating conditions of short duration.

D-14. Slug Flow Limits. The following procedure can be used to

determine the lower and upper discharge limits for a given pool level within which slug flow can be expected to occur. Reasonably good correlation was obtained between the calculated limits and those obtained from the Warm Springs Outlet Works model study (item D-1). The lower discharge limit of slug flow for any pool level is approximately equal to the minimum, part-gate discharge which will cause the conduit to flow full. The conduit is determined to flow full if a water-surface profile computation initiated at the vena contracta immediately downstream of the gate indicates that the depth will increase to about 80 to 85 percent of the conduit height before exiting the downstream portal. Entrained air is assumed to bulk the flow 15 to 20 percent and thereby effect full conduit flow with the above-computed depths of nonaerated water. The upper discharge limit for a given pool level is approximately equal to the discharge for which the downstream momentum at the vena contracta with partly full flow is equal to the upstream momentum that would occur at the gates with the same discharge if the complete conduit were flowing full. The sketch in plate D-4 defines these two conditions for computation of this discharge. For a given pool level, assume a gate opening G_0 and compute the free flow discharge Q and the momentum at the vena contracta (condition 1):

$$M_1 = A_1 \bar{y}_1 + \frac{QV_1}{g} \quad (D-1)$$

where

A = cross-sectional area of flow

\bar{y} = distance from hydraulic grade line (free surface for open-channel condition) to centroid of flow area

V = average velocity through A

Then, assuming the conduit to flow full at the same Q , compute the elevation of the piezometric grade line (PGL) at the gate (starting from the downstream portal) and the momentum of the full-conduit flow at the gate (condition 2):

$$M_2 = A_2 \bar{y}_2 + \frac{QV_2}{g} \quad (D-2)$$

Adjust the assumption of G_0 as necessary to give a value of Q that will result in equal values of M_1 and M_2 . Then make similar computations for other pool levels in the range of interest. Increasing the conduit slope will raise both limits and will narrow the band of

EM 1110-2-1602
15 Oct 80

Table D-4. Example Computation of Flow Profile at 3000 cfs using k and Chezy C

Station ft	Invert El ft msl	W.S. El ft msl	y ft	A ft ²	V fps	$\left \frac{V_2 - V_1}{\frac{V_2 + V_1}{2}} \right ^*$	$h_v = \frac{v^2}{2g}$ ft	Trial EGL El ft msl
10+70	1228.00	1238.69	10.69	183.25	16.37	--	4.17	<u>1242.86</u>
10+65	1228.01	1239.15	11.14	193.15	15.53	0.053	3.75	<u>1242.90</u>
10+50	1228.02	1239.32	11.30	196.67	15.25	0.018	3.61	<u>1242.93</u>
10+00	1228.08	1239.93	11.85	208.75	14.37	0.059	3.21	1243.14
		1239.78	11.70	205.46	14.60	0.044	3.31	1243.09
		1239.58	11.50	201.06	14.92	0.022	3.46	<u>1243.04</u>
9+00	1228.20	1239.90	11.70	205.46	14.60	0.022	3.31	<u>1243.21</u>
8+00	1228.31	1240.21	11.90	209.84	14.30	0.021	3.18	1243.39
		1240.26	11.95	210.94	14.22	0.026	3.14	<u>1243.40</u>
7+00	1228.43	1240.63	12.20	216.41	13.86	0.026	2.98	<u>1243.62</u>
6+00	1228.54	1241.01	12.47	222.31	13.50	0.027	2.83	<u>1243.84</u>
5+00	1228.66	1241.38	12.72	227.75	13.17	0.025	2.70	1244.08
		1241.36	12.70	227.32	13.20	0.023	2.71	1244.07
		1241.31	12.65	226.23	13.26	0.018	2.73	<u>1244.04</u>
4+00	1228.77	1241.57	12.80	229.49	13.07	0.014	2.66	1244.23
		1241.62	12.85	230.57	13.01	0.019	2.63	1244.25
		1241.47	12.70	227.32	13.20	0.005	2.71	<u>1244.18</u>
3+00	1228.89	1241.64	12.75	228.40	13.14	0.005	2.68	<u>1244.32</u>
2+00	1229.00	1241.80	12.80	229.49	13.07	0.005	2.66	1244.46
		1241.83	12.83	230.14	13.04	0.008	2.64	1244.47
		1241.88	12.88	231.22	12.97	0.013	2.62	<u>1244.50</u>

Note:

Q = 3000 cfs
k = 0.007 ft (capacity)
S = 0.00115
α = 1.000
D = 22.00 ft
v = 0.0000121 ft²/sec at 60° F.

* If not ≤ 0.10, reduce distance between stations.

** If in fully rough flow, C = 32.6 log₁₀ (12.1 R/k).

EM 1110-2-1602
15 Oct 80

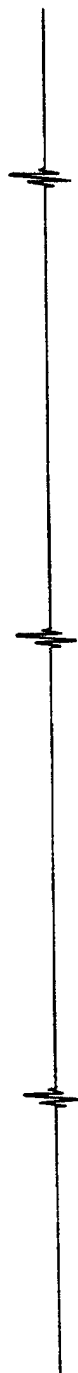

R ft	R/k	$R = \frac{4RV}{v}$	C**	$S_f = \frac{V^2}{C^2 R}$	S_f avg	L	h_f	Check EGL El ft msl	Y from CORPS H6208 ft
5.40	771.37	2.92×10^7	129.54	0.002959				<u>1242.86</u>	10.69
5.54	791	2.84×10^7	129.9	0.00258	0.002769	5	0.01	<u>1242.87</u>	11.14
5.59	798.6	2.82×10^7	130.0	0.00246	0.00252	5	0.01	<u>1242.88</u>	11.27
5.76	822.86	2.74×10^7	130.45	0.00211	0.00228	50	0.114	1242.99	
5.71	816.24	2.76×10^7	130.34	0.00220	0.00233		0.116	1243.00	
5.66	808.57	2.79×10^7	130.19	0.00232	0.00239		0.12	<u>1243.00</u>	
5.71	816.24	2.76×10^7	130.34	0.00220	0.00226	100	0.226	<u>1243.23</u>	11.62
5.77	824.48	2.73×10^7	130.48	0.00208	0.00214	100	0.21	1243.44	
5.79	826.51	2.72×10^7	130.52	0.00205	0.00202		0.20	<u>1243.43</u>	
5.86	836.43	2.68×10^7	130.69	0.00192	0.001985	100	0.198	<u>1243.63</u>	12.20
5.93	846.75	2.65×10^7	130.86	0.00179	0.00186	100	0.186	<u>1243.82</u>	12.38
5.99	855.95	2.61×10^7	131.01	0.00169	0.00174	100	0.174	1243.99	
5.99	855.71	2.61×10^7	131.01	0.00169	0.00174	100	0.174	1243.99	
5.97	853.41	2.62×10^7	130.97	0.00172	0.00175		0.175	<u>1244.00</u>	12.66
6.01	858.81	2.60×10^7	131.06	0.00166	0.00169	100	0.169	1244.17	
6.02	860.59	2.59×10^7	131.09	0.00164	0.00168		0.168	1244.17	
5.99	855.22	2.61×10^7	131.00	0.00170	0.00171		0.171	<u>1244.17</u>	
6.00	857.02	2.61×10^7	131.031	0.00168	0.00169	100	0.169	<u>1244.34</u>	12.77
6.01	858.81	2.60×10^7	131.06	0.00166	0.00167	100	0.167	1244.51	
6.02	859.88	2.60×10^7	131.08	0.00164	0.00166		0.166	1244.51	
6.03	861.64	2.58×10^7	131.11	0.00162	0.00165		0.165	<u>1244.50</u>	12.87
									12.87
									12.96

discharge within which slug flow will occur, while reducing the slope will produce the opposite effect. Changing the conduit size will primarily affect the lower limit. Increasing the size will raise the lower limit while decreasing the size will lower the lower limit. In most cases a change in both slope and size will be necessary to maintain discharge capacity and effect the desired change in band width or shift of the limits of slug flow. As the normal change combinations have opposite effects, each case will be unique and generalized guidance cannot be given.

D-15. References.

D-1. Ables, J. H., Jr., and Pickering, G. A. 1973 (Feb). "Outlet Works, Warm Springs Dam, Dry Creek, Russian River Basin, Sonoma County, California; Hydraulic Model Investigation," Technical Report H-73-3, U. S. Army Engineer Waterways Experiment Station, CE, Vicksburg, Miss.

D-2. Chow, V. T. 1959. Open-Channel Hydraulics, McGraw-Hill, New York.

D-3. Falvey, H. T. "Air-Water Flow in Hydraulic Structures" (in preparation), Engineering Monograph 41, U. S. Bureau of Reclamation, Denver, Colo.

D-4. King, H. W., and Brater, E. F. 1963. Handbook of Hydraulics for the Solution of Hydrostatic and Fluid-Flow Problems, 5th ed., McGraw-Hill, New York.

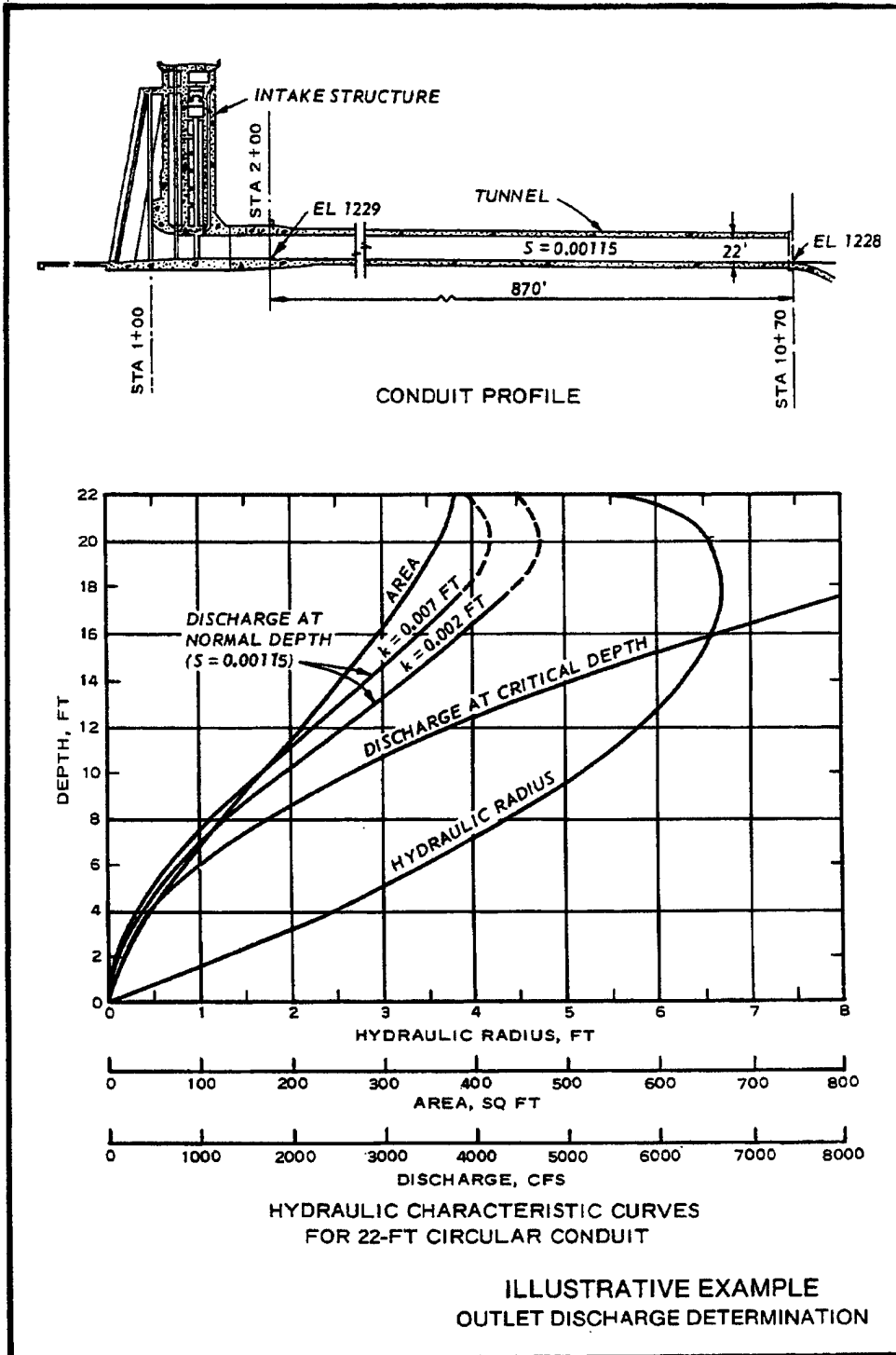

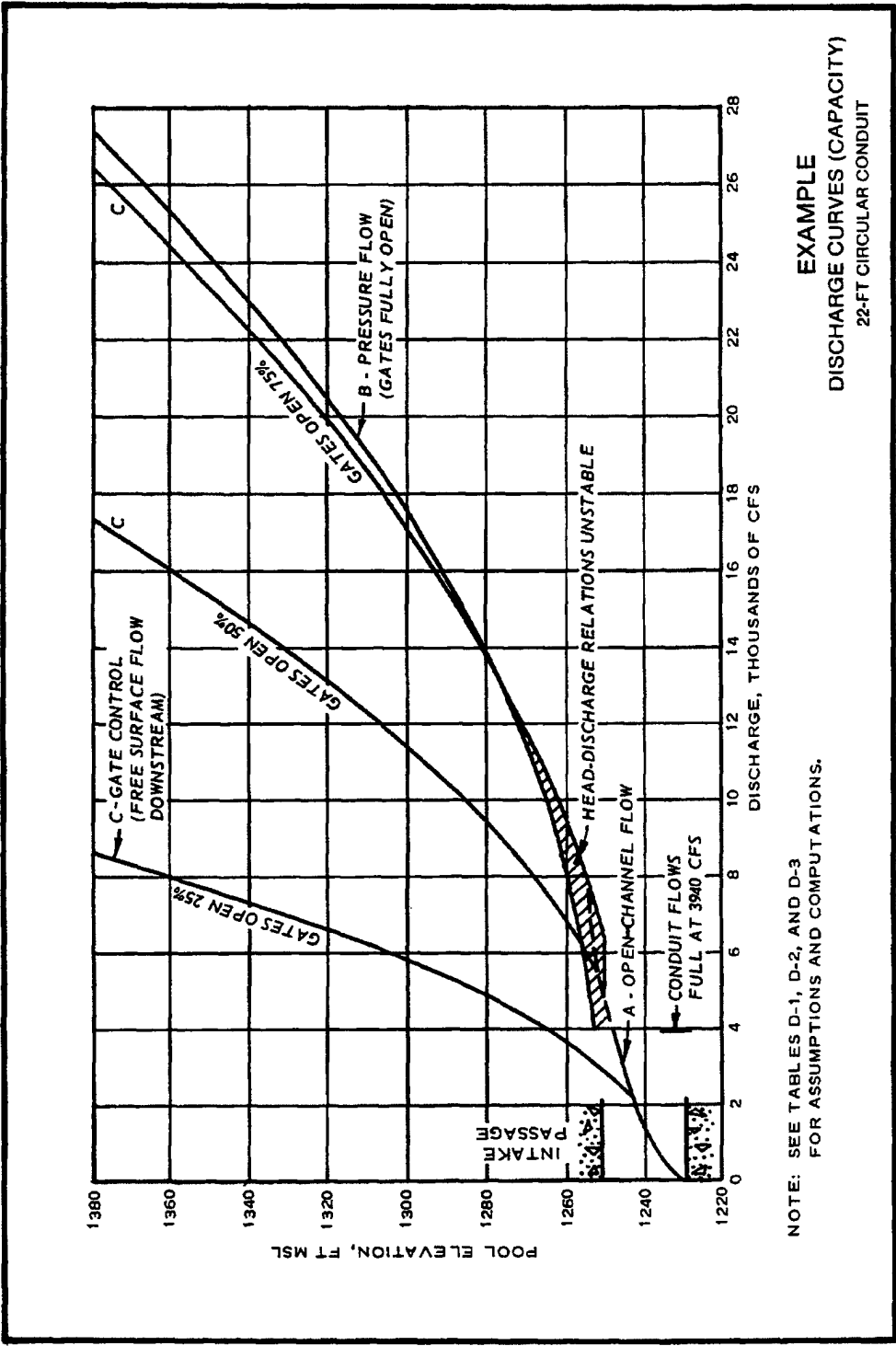

EXAMPLE
DISCHARGE CURVES (CAPACITY)
22-FT CIRCULAR CONDUIT

NOTE: SEE TABLES D-1, D-2, AND D-3
FOR ASSUMPTIONS AND COMPUTATIONS.

PLATE D-2

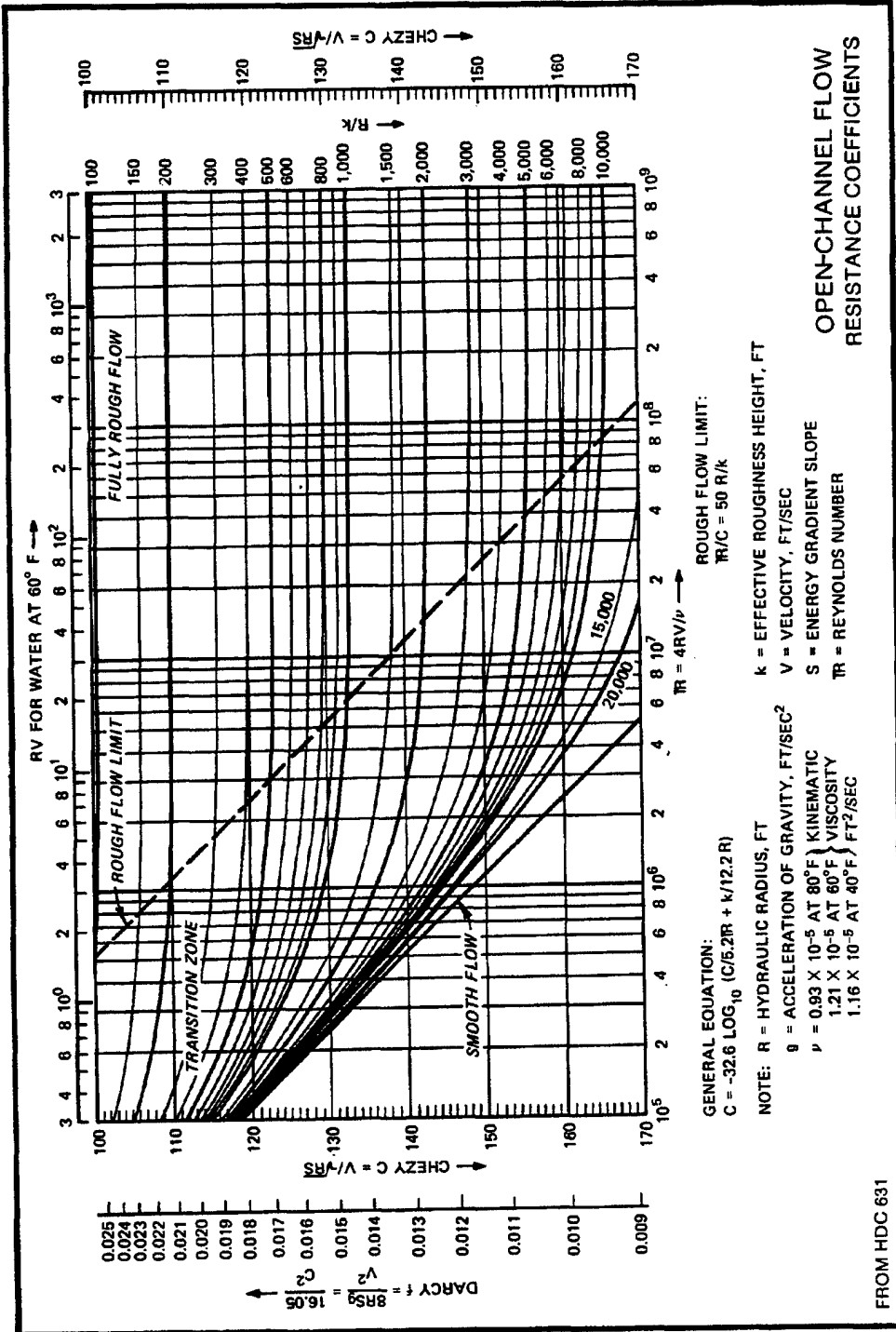

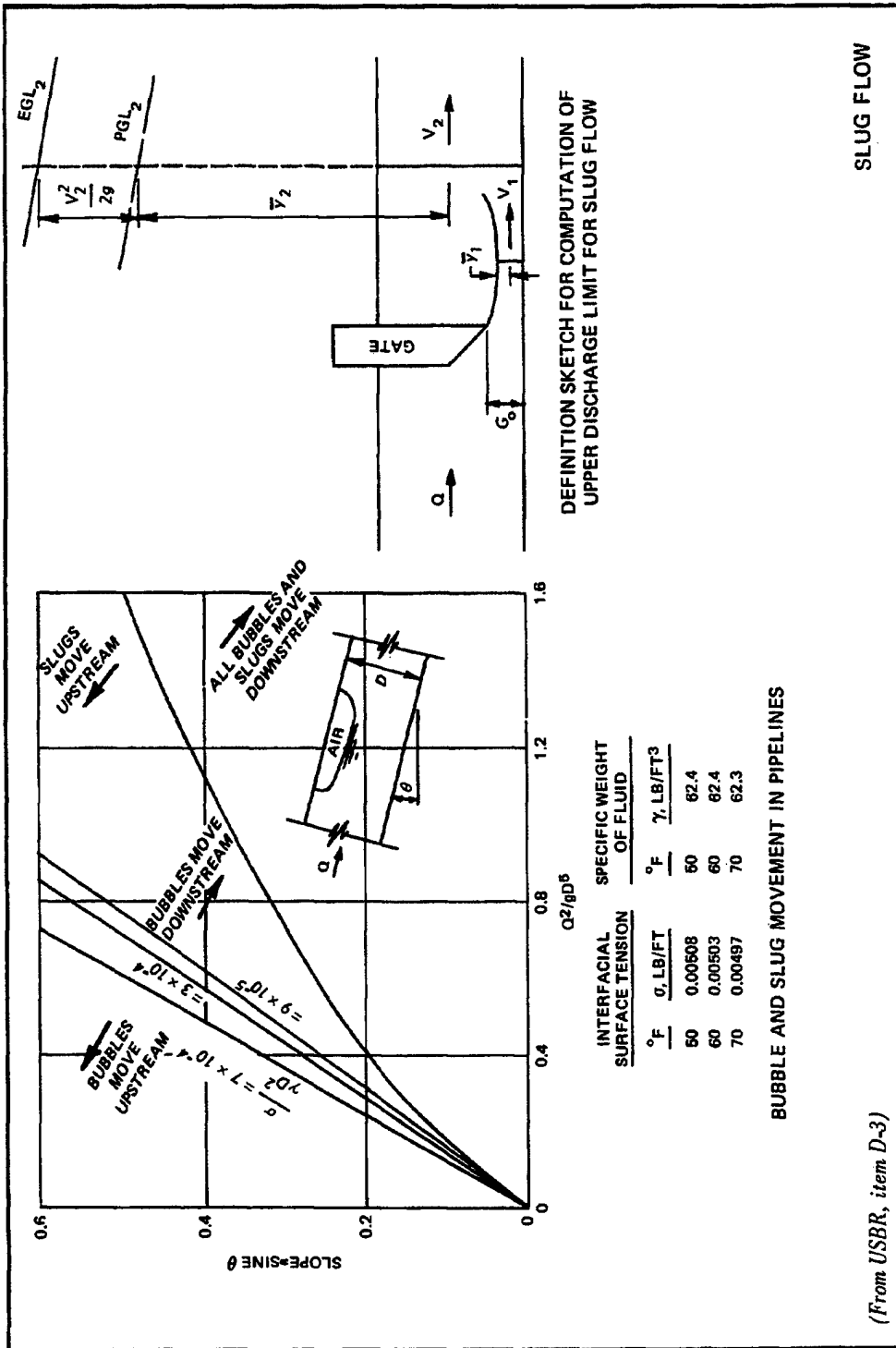

SLUG FLOW

(From USBR, item D-3)

APPENDIX E

COMPUTATION FOR DESIGN OF TRANSITION SECTION
(Illustrative Example)

E-1. Introduction. The following example is presented to illustrate the principles of transition design discussed in paragraph 4-22. The transition considered is located between a two-gate intake gate section and a circular conduit, and the design involves only horizontal convergence. However, the procedure discussed is applicable to transitions having both horizontal and vertical convergences.

E-2. Design Conditions. The example intake gate section consists of two 9- by 20-ft parallel rectangular conduits separated by a 6-ft-thick pier. The downstream conduit is 20 ft in diameter resulting in an area reduction of 12.8 percent. Maximum discharge will be 50,000 cfs. All curves should be selected to effect gradual changes in the direction of flow. The necessary outer wall convergence is formed by reverse curves of equal radii. The pier taper is also curved. The minimum thickness of the tapered pier section has been limited to 2 ft for structural reasons. Tangent extensions from the end of the pier are assumed to enclose a nonflow area, which is believed to be realistic. The end of the pier is blunt to ensure a stable point of separation of the flow from the pier. The fillet design conforms to circular quadrants of varying radii to accomplish the required geometric change from rectangular to circular and to provide a gradual area reduction. The general transition layout is shown in plate E-1.

E-3. Design Computations. Transition designs are generally based on simple curves and tangents which result in relatively easy but laborious design computations. Therefore, detailed computations are omitted from this illustration but the general procedure and equations are included as a guide.

E-4. Convergence Computations.

a. Area Reduction. The percent area reduction is computed by the following equation:

$$\Delta A \text{ (percent)} = 100 \left(1 - \frac{A_d}{A_u} \right) = 100 \left(1 - \frac{314}{360} \right) = 12.8\% \quad (\text{E-1})$$

where

A_d = downstream circular conduit area

A_u = upstream total gate section area

b. Transition Length. The required transition length (L_T) is based on flow conditions and a limiting angle of contraction by the more conservative of the computations:

$$L_T = (R_u - R_d) \left(\frac{V}{\sqrt{gD}} \right) \quad (E-2a)$$
$$= (15.62 - 10) \left[\frac{149}{\sqrt{32.2} (20.70)} \right] = 32.4 \text{ ft}$$

where

$R_u - R_d$ = maximum radial offset from the outside boundary upstream to the corresponding location in the conduit boundary downstream

V, D = average of the velocities and equivalent area diameters at the upstream and downstream end of the transition (139 and 159 fps; 21.41 and 20 ft)

$$L_T = \frac{(R_u - R_d)}{\tan \theta} = \frac{(15.62 - 10)}{0.1228} = 45.8 \text{ ft (use 46 ft)} \quad (E-2b)$$

where θ is the maximum allowable angle of contraction of the boundary relative to the conduit axis (use $\theta = 7^\circ$).

c. Wall Curves. The sidewall transition curves are composed of reverse circular arcs of equal radii and therefore are defined by the equation:

$$r_W = \frac{x_{\text{PRC}}^2}{2e} + \frac{e}{2} = \frac{(23)^2}{2(1)} + \frac{1}{2} = 265 \text{ ft} \quad (E-3)$$

where

r_w = wall curve radius

X_{PRC} = conduit center-line distance PC to PRC or PRC to end of transition ($=L_T/2$)

e = one-half of convergence of one wall from PC to end of transition

d. Pier Curves. The pier curves are also composed of circular arcs of equal radii and are based on equation E-3 (with $e = 1.5$ ft in example). Additional computations are required to locate the pier curve PT where the minimum pier thickness is 2 ft. In these computations the curve (r_p) is considered to start at the conduit center line at the end of the transition and extend upstream to (X_{PT}) to the point where the example value of e is 1 ft.

e. Tangent Extension. The slope of the tangent extension ($\tan \theta_p$) and its intersection with the conduit center line are required for the area computations and may be computed using the following equations:

$$\tan \theta_p = \frac{X_{\text{PT}}}{r_p - e} \quad (\text{E-4})$$

$$X_T = \frac{e}{\tan \theta_p} = \frac{(r_p - e) e}{X_{\text{PT}}} \quad (\text{E-5})$$

where

r_p = radius of pier curve

X_{PT} = conduit center-line distance from pier PT to end of transition

$e = 0.5$ minimum pier thickness

X_T = conduit center-line distance from pier PT to the intersection of the tangent extension and the conduit center line

E-5. Area Curves. The development of a transition area curve requires area computations at cross sections normal to the transition center line. These sections are usually selected close together at the beginning and end of the transition to accurately define the curve in the region where

the slope of the curve is approaching zero. The shape of the curve depends upon the horizontal and vertical convergences of the outer walls and the taper of the pier as well as upon the radii of the quadrant fillets. When the horizontal and vertical convergences are fixed (plate E-1), an area curve for the converging rectangular sections (plate E-2) is helpful in designing the fillets which result in the final transition area curve. Several trial fillet designs are usually required in the development of a satisfactory curve.

a. Areas of Converging Rectangular Sections. The computation of the areas of the converging rectangular sections requires determination of the distances of the walls, pier surface, and tangent extension from the conduit center line at the selected sections. The curve and tangent extension equations previously discussed can be used for these computations. The total flow width at each section is multiplied by the transition height to obtain the cross-sectional area. With vertical convergence the appropriate height at each section is used. The resulting areas are plotted as shown in plate E-2.

b. Fillet Quadrant Design. The design of the quadrant fillets necessitates the determination of fillet radii that will adjust the converging rectangular sections to provide a smooth, gradually changing area curve as well as result in gradual changes in the direction of flow along the fillets. Preliminary computations based on uniform variation of the fillet radius from zero at the beginning of the transition to the conduit radius at the end of the transition are helpful in developing final radii for the fillets. A satisfactory area curve was obtained by use of nonuniformly varying fillet radii defined by circular arcs near the upstream and downstream ends of the transition and uniformly varying radii in the middle section, as shown by the fillet radius plot in plate E-2. Tangent distances of 2 and 5 ft, selected for the upstream and downstream arcs, respectively, resulted in a slope of 0.25641 on 1 for the uniformly varying radius curve. The fillet radius (r_f) for each section was then computed using the following equation:

Upstream arc

$$r_f = r_a - (r_a^2 - x^2)^{1/2} \quad (E-6)$$

Downstream arc

$$r_f = \frac{D}{2} - \left\{ r_a - \left[r_a^2 - (L_T - x)^2 \right]^{1/2} \right\} \quad (E-7)$$

Uniformly varying fillet radii

$$r_f = \text{slope} (x - \text{tangent length of upstream arc}) \quad (\text{E-8})$$

where

r_f = fillet radius

r_a = arc radius

x = center-line distance from beginning of transition

c. Fillet Area. The full fillet area to be subtracted from the rectangular cross-sectional area is computed by the equation

$$A_f = 0.8584 r_f^2 \quad (\text{E-9})$$

where

A_f = fillet area

r_f = fillet radius

The final transition area curve is shown in plate E-2. This curve has a zero slope at both ends of the transition. The slight irregularity in the curve near the downstream end results from use of the tangent extensions in the area computations rather than theoretically extending the pier curve to the end of the transition.

E-6. Fillet at 45-Deg Point. The change in direction of flow along the 45-deg points of the fillets should be smooth and gradual. The path of the flow is three-dimensional and cannot be readily illustrated. However, examination of the locus of the 45-deg point in the horizontal (X) plane and the vertical (Y) plane is helpful in judging the smoothness and rate of change in direction. Such a plot referenced to the conduit center line is shown in plate E-2 and indicates a smooth and gradual change in the direction of flow. Computation of the coordinates (X and Y) of the 45-deg points (Point C on Section C-C, plate E-2) is accomplished using the following relations:

$$c = r_f \text{versine } 45^\circ \quad (\text{E-10})$$

$$x = 0.5t_w - c \quad (\text{E-11})$$

15 Oct 80

and

$$y = 0.5t_h - c \quad (E-12)$$

where

c = horizontal or vertical distance from corner of local rectangular section

r_f = local fillet radius

t_w = local transition half width

t_h = local transition half height

E-7. Transition Pressures. General pressure conditions throughout the transition can be computed by examination of the change in velocity head from section to section. However, local pressure conditions can only be investigated by means of a model study. Model experience indicates that undesirable pressure conditions may exist immediately downstream from the transition unless the transition is carefully designed. These conditions result from the relative outward flare of the boundary as it changes from converging to straight.

E-8. Layout Data Information. Plates E-1 to E-3 illustrate transition drawings and data pertinent to review of transition designs and to field construction. Plate E-1 illustrates the general transition layout and fillet intersections with the sides and floor of the transition. Plate E-2 shows graphically the variations in the fillet radii, the transition area, and the locus of the fillet 45-deg point. Superimposed upstream, middle, and downstream transition sections are also shown in this plate to illustrate the geometric changes from section to section and to identify data tabulated in plate E-3.

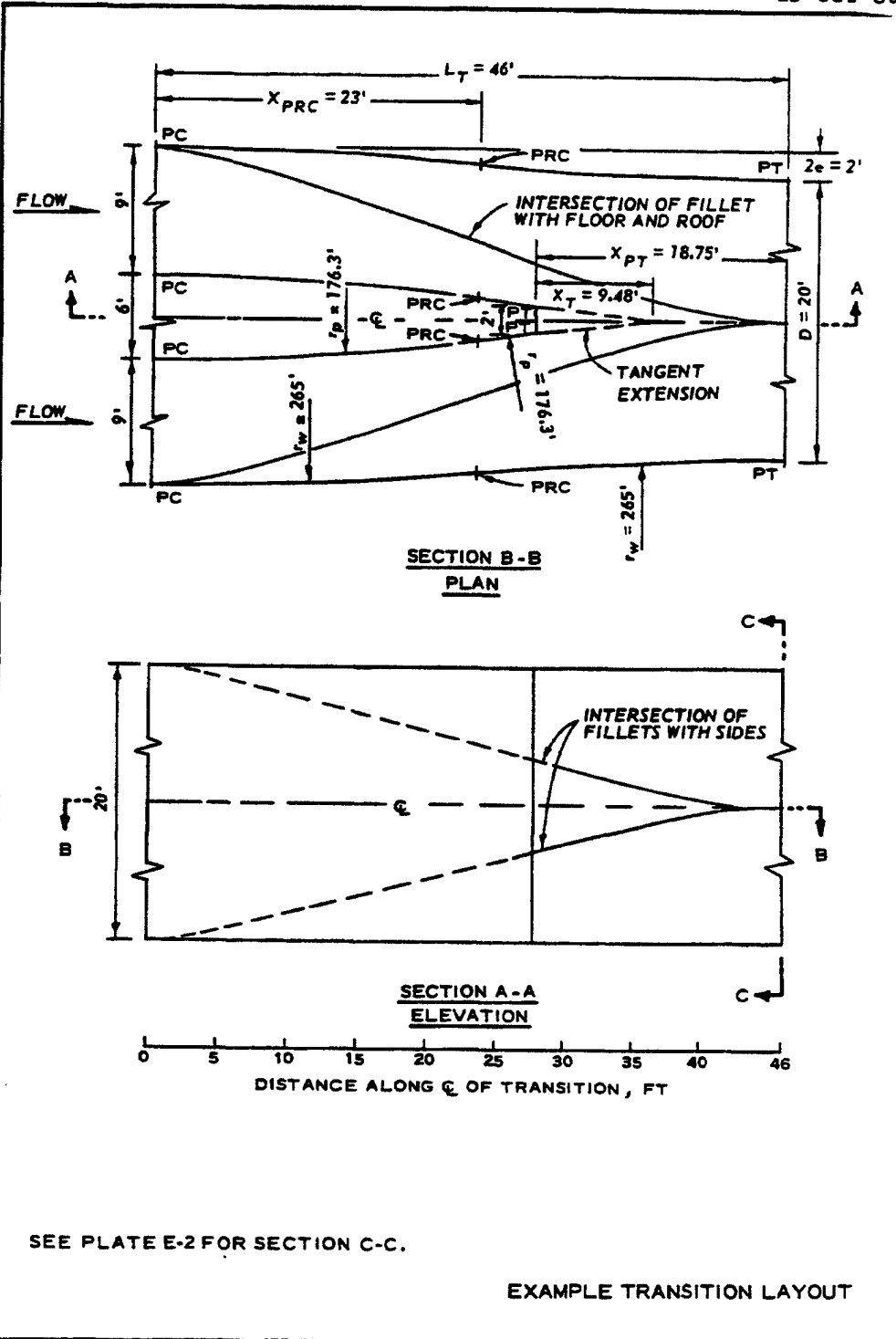

EM 1110-2-1602
 15 Oct 80

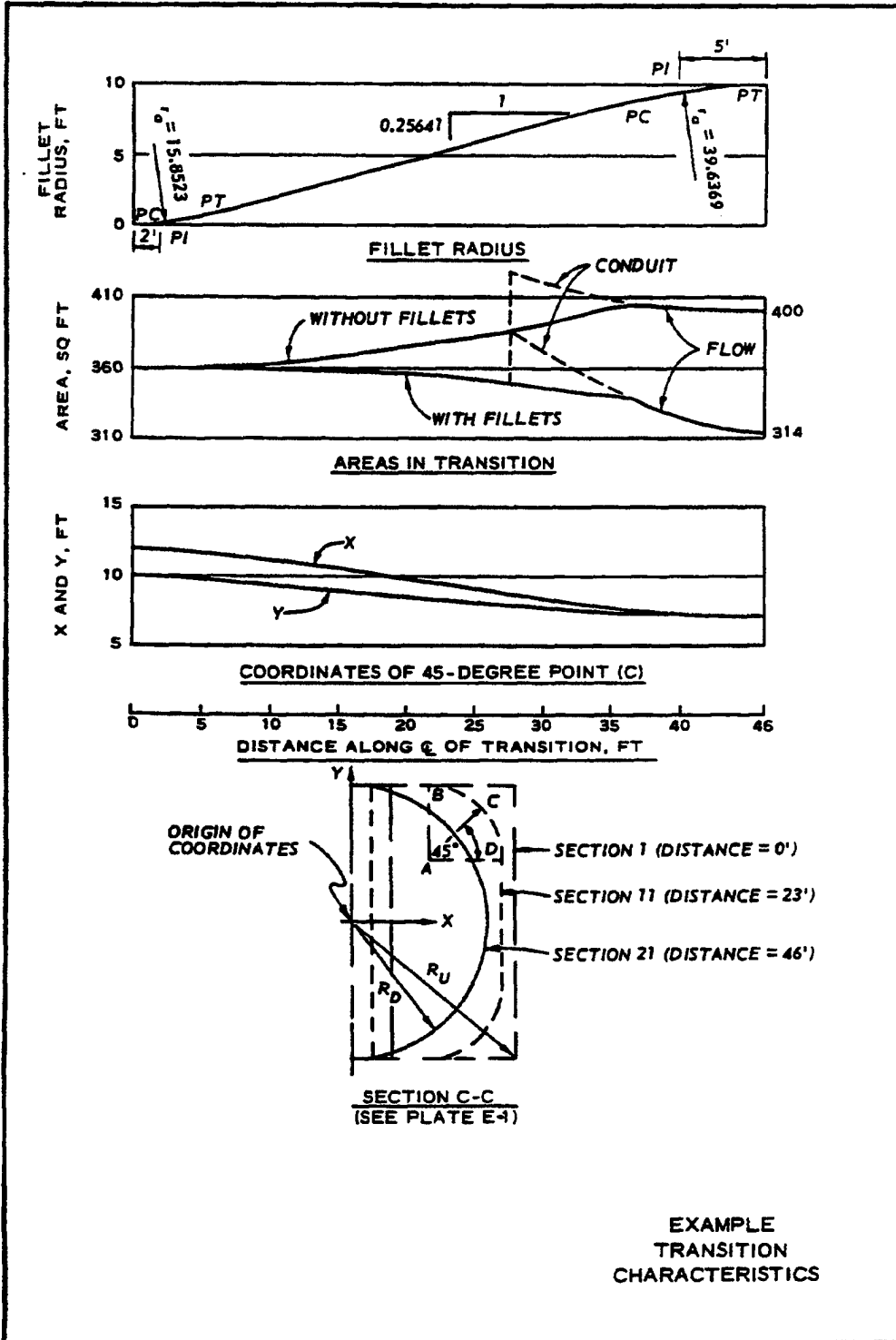

PLATE E-2

COORDINATES OF POINTS IN FIRST QUADRANT

SECTION	DISTANCE ALONG CENTER LINE OF TRANSITION FT	LENGTH OF FILLET RADIUS FT	HALF-WIDTH OF PIER FT	POINT A		POINT B		POINT C		POINT D	
				X FT	Y FT	X FT	Y FT	X FT	Y FT	X FT	Y FT
1	0	0	3.0000	12.0000	10.0000	12.0000	10.0000	12.0000	10.0000	12.0000	10.0000
2	1	0.0316	2.9972	11.9685	9.9684	11.9685	9.9684	11.9688	9.9907	11.9981	9.9684
3	2	0.1267	2.8887	11.8657	8.8733	11.8657	8.8733	11.9553	9.9629	11.9924	9.8733
4	3	0.2865	2.6748	11.6965	8.7135	11.6965	8.7135	11.8991	9.9161	11.9830	9.7135
5	4	0.5128	2.3548	11.4570	8.4872	11.4570	8.4872	11.8196	9.8498	11.9698	9.4872
6	6	1.0256	2.8983	10.9065	8.9744	10.9065	8.9744	11.6317	9.6956	11.9321	8.9744
7	10	2.0513	2.7174	9.7599	7.8487	9.7599	7.8487	11.2104	9.3992	11.8112	7.9487
8	14	3.0769	2.4457	8.5530	6.8231	8.5530	6.8231	10.7287	9.0988	11.6299	6.9231
9	18	4.1026	2.0828	7.2854	5.8974	7.2854	5.8974	10.1864	8.7984	11.3880	5.8974
10	21	4.8718	1.7504	6.2948	5.1282	6.2948	5.1282	9.7397	8.5731	11.1666	5.1282
11	23 (PRC)	5.3846	1.5000	5.6154	4.6154	5.6154	4.6154	9.4229	8.4229	11.0000	4.6154
12	25	5.8974	1.2466	4.9360	4.1026	4.9360	4.1026	9.1081	8.2727	10.8334	4.1026
--	27.25										
13	28	6.6666	0.9165*	3.9454	3.3334	3.9454	3.3334	8.6594	8.0474	10.8120	3.3334
14	32	7.6923	0.4885*	2.8778	2.3077	2.8778	2.3077	8.1171	7.7470	10.3701	2.3077
15	36	8.7179	0.0616*	1.4709	1.2821	1.4709	1.2821	7.6354	7.4466	10.1888	1.2821
--	38.73										
16	40	9.5432	0	0.5247	0.4568	0.5247	0.4568	7.2728	7.2049	10.0879	0.4568
17	42	9.7976	0	0.2328	0.2024	0.2328	0.2024	7.1606	7.1304	10.0302	0.2024
18	43	9.8863	0	0.1307	0.1137	0.1307	0.1137	7.1214	7.1044	10.0170	0.1137
19	44	9.9495	0	0.0581	0.0505	0.0581	0.0505	7.0935	7.0859	10.0076	0.0505
20	45	9.9874	0	0.0145	0.0126	0.0145	0.0126	7.0787	7.0748	10.0019	0.0126
21	46	10.0000	0	0	0	0	0	7.0711	7.0711	10.0000	0

(END AND PT OF PIER)

(END OF TANGENT EXTENSION)

* BASED ON TANGENT EXTENSION.

NOTE:

COORDINATES OF POINTS IN OTHER QUADRANTS CAN BE OBTAINED BY APPROPRIATE CHANGES OF THE SIGN OF THE TABULATED VALUES.

SEE PLATE E-2 FOR DEFINITION SKETCH.

EXAMPLE TRANSITION SECTION COORDINATES

APPENDIX F

COMPUTATION FOR DESIGN OF OUTLET WORKS STILLING BASIN
(Illustrative Examples)

F-1. Introduction. The following detailed examples are presented to illustrate the procedures for the design of outlet works stilling basin discussed in Chapter 5. Two examples with different tailwater and exit channel elevations are used to illustrate a normal design and a design for a low-level outlet with respect to tailwater where eddy problems within the stilling basin are likely to occur. (Note: These calculations may also be performed using the computer program H2261, Stilling Basin Design for Conduit Outlet Works, found in the USAE computer program library, CORPS.) *

F-2. Design Conditions. The following information is used for design example:

Conduit diameter $D = 14$ ft
 Conduit slope $S = 0.01$ ft/ft ($\theta = 0^\circ 34.5' = 0.573^\circ$)
 Design discharge $Q = 12,320$ cfs (for smooth pipe and design pool)
 Elevation outlet portal invert = 100 ft msl

Case 1:

Exit channel invert elevation = 90 ft msl
 Tailwater rating curve shown in plate F-1

Case 2:

Exit channel invert elevation = 98 ft msl
 Tailwater rating curve shown in plate F-1

F-3. Design Computations.a. Transition Sidewall Flare.

$$\text{Conduit area } A = \frac{\pi D^2}{4} = \frac{3.14(14)^2}{4} = 154 \text{ ft}^2$$

$$Q = 12,320 \text{ cfs}; V_{sm} = 80.0 \text{ fps}$$

$$F = \frac{V_{sm}}{\sqrt{gD}} = \frac{80.0}{\sqrt{32.2(14)}} = 3.77$$

From equation 5-2, paragraph 5-2d

$$\Delta L = 2 F = 2(3.77) = 7.54 \quad \text{Since } \Delta L > 6, \text{ use } \Delta L = 7.54$$

b. Radius to Connect Outlet to Sidewall. The shape change from circular to rectangular cross section will be made with free surface flow.

$$R = 5D = 5(14) = 70 \text{ ft}$$

$$L_t = \text{tangent length} = R \tan \frac{\phi}{2} = 70 \tan \left(\frac{1}{2} \text{Arc tan } \frac{1}{7.54} \right) = 4.61'$$

c. Length of Fillets.

$$L_f = 1.5D = 1.5(14) = 21 \text{ ft}$$

Therefore invert must continue on slope of conduit (0.01 ft/ft) for a distance of 21 ft.

d. Parabolic Invert Drop. Using equation 5-3 paragraph 5-2d(3).

$$y = -x \tan \theta - \frac{gx^2}{2(1.25 v_{sm})^2 \cos^2 \theta}$$

$$1.25 v_{sm} = 100 \text{ fps}$$

therefore

$$y = -x \tan 0.573^\circ - \frac{32.2x^2}{2(100)^2 \cos^2 0.573^\circ}$$

or

$$y = -0.01x - 0.00161x^2$$

e. Case 1 Design.

(1) Stilling Basin Geometry. From plate F-1, the tailwater elevation at design discharge (12,320 cfs) is 100.2 ft msl. Assume various basin apron elevations and compute basin width (W_b), entering flow depth (d_1), * entering flow velocity (V_1), Froude number of entering flow (F_1), required downstream depth to force jump (d_2), $0.85d_2$ and actual depth from apron floor to tailwater water surface (d). Assume energy losses between outlet portal and basin apron are negligible, i.e.,

$$\frac{v^2}{2g} + y_p = \frac{v_1^2}{2g} + d_1 - (\text{Outlet el} - \text{Apron el})$$

where y_p = height of pressure grade line at exit portal (plate C-3)

$$= 0.57D = 0.57(14) = 8.0 \text{ ft}$$

and

$$d_1 = \frac{Q}{V_1 W_b}$$

$$\text{Also } W_b = D + \frac{2(X+L_f-L_t)}{\Delta L} = 14 + \frac{2(X+21-4.61)}{7.54} = 14 + \frac{X+16.39}{3.77}$$

where X is determined from the parabolic equation after Y is determined from assumed apron elevation. This can be simplified by making a plot of x versus y for the parabolic invert drop equation (plate F-2).

$$\begin{aligned} \text{Then } -Y &= \text{El outlet} - S(L_f) - \text{Apron El} \\ &= 100 - 0.21 - \text{Apron El} = 99.79 - \text{Apron El} \end{aligned}$$

Table F-1

Computations for Determining Basin Apron Elevation (Case 1)

(1) Q cfs	(2) Apron El msl	(3) Y ft	(4) X ft	(5) W_b ft	(6) V_1 fps	(7) d_1 ft	(8) F_1	(9) d_2 ft	(10) $0.85d_2$ ft	(11) Actual d ft
12,320	80	-19.79	107.84	46.96	89.55	2.93	9.22	36.76	31.25	20.20
12,320	65	-34.79	143.98	56.54	95.01	2.29	11.06	34.73	29.52	35.20
12,320	70	-29.79	133.00	53.63	93.25	2.46	10.47	35.26	29.97	30.20
O.K.										
Check jump with lesser discharges										
8,000	70	-29.79	133.00	53.63	71.16	2.10	8.66	24.65	20.95	30.20
4,000*	70	-29.79	133.00	53.63	59.82	1.25	9.44	16.04	13.63	26.2

NOTE: See explanatory notes on page F-4.

Explanatory Notes for Table F-1

- (1) Design discharge (* Denotes partially full conduit flow condition.
 $Q_{full} = 4408$ cfs)
- (2) Assumed value of apron el
- (3) Computed from $-Y = \text{El outlet} - S(L_p) - \text{Apron El}$
- (4) With computed value of Y (Step 3) compute X

$$* \quad Y = -X \tan \theta - \frac{gX^2}{2(1.25V)^2 \cos^2 \theta} \quad *$$

Solve by quadratic formula, graphically or numerically

- (5) Width of stilling basin

$$* \quad W_b = D + \frac{2(X+L_f-L_c)}{\Delta L} \quad *$$

- (6) Flow velocity in stilling basin at section 1

$$\frac{v^2}{2g} + y_p = \frac{v_1^2}{2g} + \frac{Q}{v_1 W_b} - (\text{Outlet el} - \text{Apron el})$$

Solve for v_1 either graphically or numerically (cubic equation).

- (7) Flow depth at section 1

$$d_1 = \frac{Q}{v_1 W_b}$$

- (8) Froude number of flow at section 1

$$F_1 = \frac{v_1}{\sqrt{gd_1}}$$

- (9) Sequent depth in stilling basin at section 2

$$* \quad d_2 = \frac{d_1}{2} \left(\sqrt{1 + 8 F_1^2} - 1 \right) \quad *$$

- (10) Sequent depth (d_2) multiplied by 0.85

- (11) Actual depth at section 2

$$d = \text{Tailwater el} - \text{Apron el}$$

Results:

Stilling basin apron elevation = 70 ft msl
 Stilling basin width $W_b = 53.6$ ft
 Transition Length = $L_f + X = 154$ ft
 Stilling basin length $L_B = 3d_2 = 3(35.26) = 105.8$ or 106 ft

(2) Baffle Piers. Since the stilling basin apron elevation was set at $0.86 d_2$ for tailwater at the design discharge, two rows of baffle piers should be used.

Height of baffle piers $d_1 = 2.46$ ft; say 2.5 ft.
(Check $1/6 d_2 = 35.26/6 = 5.48$ ft \therefore 2.5 ft o.k.)

Since velocity entering basin is greater than 60 fps, first row of baffles should be placed farther than $1.5 d_2$ downstream from toe of parabolic drop.

Since $1.5 d_2 = 1.5(35.26) = 52.9$ ft, place first row of baffles 60 ft downstream. This is based on judgment depending on flow velocity entering basin. Second row should be approximately $0.5 d_2$ farther downstream, or $0.5 d_2 = 0.5(35.26) = 17.6$ ft. Thus, place second row 18 ft downstream from first row. Make width of baffles and spacing equal to baffle height or 2.5 ft.

(3) End Sill. The height of end sill should be half of the baffle height or $0.5(2.5) = 1.25$ ft, and the upstream face should have a IV-on-IH slope.

(4) Determination of Low-Level Outlet. Check to determine if conduit outlet portal is low with respect to tailwater for low flows. Determine section in the transition where parabolic invert slope is IV on 6H.

$$y = -0.01x - 0.00161x^2$$

thus

$$\frac{dy}{dx} = -0.01 - 0.00322x = -\frac{1}{6} = -0.1667$$

or

$$x = 48.66 \text{ ft}$$

and

$$y = -4.3 \text{ ft}$$

Thus, invert elevation of section is $100.00 - 0.21 - 4.30 = 95.49$ ft msl, and the local width of basin on the sloping apron $W_s = 14 + (48.66 + 16.39)/3.77 = 31.25$ ft. Computed d_2 elevations for lesser discharges

and the corresponding tailwater elevations are compared in table F-2.

The d_2 elevations are well above the tailwater elevations and there should be no eddy problems in the stilling basin.

Table F-2
 TAILWATER ELEVATION VERSUS d_2 ELEVATION FOR LOW FLOWS

(1)	(2)	(3)	(4)	(5)	(6)	(7)	(8)	(9)	(10-1)	(10-2)
Q	d	V	W_s	V_s	d_{1s}	F_1	d_{2s}	El	Case 1	Case 2
cfs	ft	fpa	ft	fpa	ft		ft	msl	msl	msl
500*	3.18	19.03	31.25	28.66	0.56	6.76	5.06	100.55	91.5	101.3
1,000*	4.53	23.19	31.25	32.51	0.98	5.77	7.56	103.05	92.5	103.2
1,500*	5.63	25.90	31.25	35.16	1.37	5.30	9.58	105.07	93.2	104.2

Explanatory Notes for Table F-2

- (1) Low flow discharge (* Denotes partially full flow condition. $Q_{full} = 4408$ cfs)
- (2) Normal depth for assumed discharge (assuming $n = 0.012$)
- (3) Normal velocity, $V = Q/A$ where A is area of flow for the computed normal depth
- (4) Width of transition at point where invert slope equals 1/6

$$W_s = D + \frac{2(x+L_f-L_c)}{\Delta L}$$

where $x = 48.66$ ft, $L_f = 21$ ft, $L_c = 4.61$ ft and $\Delta L = 7.54$ ft

- (5) Flow velocity at section where slope equals 1/6

$$\frac{V_s^2}{2g} + d = \frac{v^2}{2g} + \frac{Q}{V_s W_s} \quad \text{(Outlet el - Invert el at section)}$$

Solve for V_s either graphically or numerically (cubic equation)

- (6) Flow depth at section where slope invert slope equals 1/6

$$d_{1s} = \frac{Q}{V_s W_s}$$

- (7) Froude number of flow at section where invert slope equals 1/6

$$F_1 = \frac{V_s}{\sqrt{gd_{1s}}}$$

- (8) Sequent depth of d_{1s} at section where invert slope equals 1/6

$$d_{2s} = \frac{d_{1s}}{2} \left(\sqrt{1 + 8F_1^2} - 1 \right)$$

- (9) Water-surface elevation corresponding to alternate depth at section where invert slope equals 1/6

$$El. d_2 = 95.49 + d_{2s}$$

- (10) Tailwater elevation corresponding to given discharge (Case 1 and Case 2).

(5) Riprap Design. The average velocity over the end sill is used in HDC 712-1ⁿ to determine minimum riprap size (W_{50} and/or D_{50}).

$$V = \frac{Q}{A} = \frac{12,320}{53.6 (30.2 - 1.5)} = 8.0 \text{ fps}$$

From HDC 712-1ⁿ with specific weight of stone of 165 lb/ft³ and $V = 8.0$ fps, $W_{50} = 45$ lb and $D_{50} = 0.80$ ft or 9.6 in.; use $D_{50} = 12$ in. * or greater. The extent of riprap downstream depends on local scour conditions and exit channel configuration. Details of the stilling basin and recommended outlet channel configuration are shown in plates F-3 and F-4, respectively.

f. Case 2 Design.

(1) Stilling Basin Geometry. From plate F-1, the tailwater elevation at design discharge (12,320 cfs) is 118.6 ft msl. Assume various basin apron elevations and make computations as in paragraph F-3c above and similar to table F-1.

Table F-3
Computations for Determining Basin Apron Elevation (Case 2)

(1) Q cfs	(2) Apron El msl	(3) Y ft	(4) X ft	(5) W_b ft	(6) V_1 fps	(7) d_1 ft	(8) F_1	(9) d_2 ft	(10) $0.85d_2$ ft	(11) Actual d ft
12,320	80	-19.79	107.84	46.96	89.55	2.93	9.22	36.76	31.25	38.60
12,320	90	-9.79	74.96	38.23	85.57	3.77	7.77	39.54	33.61	28.60
12,320	86	-13.79	89.53	42.10	87.21	3.36	8.39	38.17	32.46	32.60
O.K.										
Check jump with lesser discharges										
8,000	86	-13.79	89.53	42.10	63.05	3.01	6.40	25.81	21.94	29.50
4,000*	86	-13.79	89.53	42.10	50.06	1.90	6.40	16.26	13.82	23.20

* Denotes partially full flow condition, $Q_{full} = 4,408$ cfs.

(Same column-by-column description (explanatory notes) as table F-1.)

Thus,

Stilling basin apron elevation = 86 ft msl

Stilling basin width $W_b = 42.1$ ft

Transition length = $L_t + X = 1.5D + X = 110.5$ ft

Stilling basin length $L_b = 3d_2 = 3(38.17) = 114.5$ or 115 ft

EM 1110-2-1602
Change 1
15 Mar 87

F-3f(2)

(2) Baffle Piers.

Height of baffle piers = $d_1 = 3.36$ ft, say 3.5 ft.

(Check $1/6d_2 = 38.17/6 = 6.36$ ft \approx 3.5 ft o.k.)

Since velocity entering basin is greater than 60 fps, first row of baffles should be placed farther than $1.5d_2$ downstream from toe of parabolic drop, i.e.,

$$1.5d_2 = 1.5(38.17) = 57.3 \text{ ft}$$

Therefore, place first row 65 ft downstream from toe of transition. Second row should be approximately $0.5d_2$ farther downstream or

$$0.5d_2 = 0.5(38.17) = 19.1, \text{ say } 20 \text{ ft}$$

Make width and spacing equal to baffle height or 3.5 ft

(3) End Sill. The height of end sill should be half of the baffle height or $0.5(3.5) = 1.75$ ft, and the upstream face should have a IV-on-1H slope.

(4) Determination If Low-Level Outlet. Check to determine if outlet portal is low with respect to tailwater for low flows as for Case 1. The section in the transition where the invert slope was equal to IV on 6H was at $x = 48.66$ ft, $y = 4.3$ ft, and invert elevation was 95.49 ft msl. (Case 1 - para F-3e(4)). The tailwater rating curve for Case 2 (plate F-1) indicates that the tailwater elevations for lesser discharges are considerably higher than 95.49, therefore, check d_2 elevation versus tailwater elevations for several low flows as in table F-2. Since the tailwater elevation is above the elevation of d_2 at the section where the slope is IV on 6H for discharges of approximately 1100 cfs and less, an eddy problem is likely to occur with these low flows. Thus, an inverted V is needed along the center line of the trajectory. The center-line elevation of the inverted V at a distance L_f downstream from the outlet portal is $100 + 0.19D = 100 + 2.66 = 102.66$. Thus, $y = 102.66 - 86$ (stilling basin apron elevation) = 16.66 ft and $x = 89.5$ ft from $y' = -C_m x^2$

$$C_m = \frac{16.66}{(89.5)^2} = 0.0021$$

Thus, the equation of the center-line trajectory will be $y' = -0.0021 x^2$. The trajectory is shown on Plate F-5.

(5) Riprap Design.

$$\text{Average velocity over end sill} = \frac{Q}{A} = \frac{12,320}{42.1(32.6 - 2.0)} = 9.6 \text{ fps}$$

From HDC 712-1ⁿ $W_{50} = 135 \text{ lb}$, $D_{50} = 1.16 \text{ ft}$ or 13.9 in.

* Use $D_{50} = 15 \text{ in.}$ or larger *

Details of stilling basin and outlet channel are shown in plates F-5 and F-6.

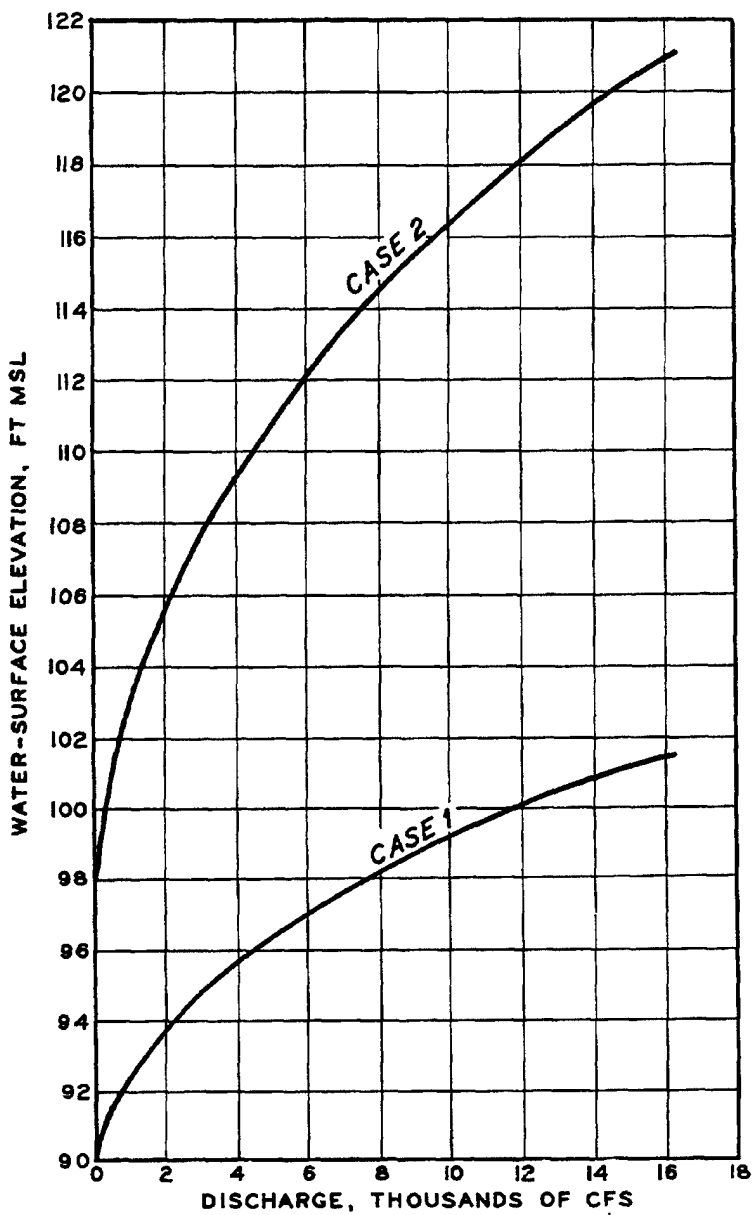

TAILWATER RATING CURVE

EM 1110-2-1602
15 Oct 80

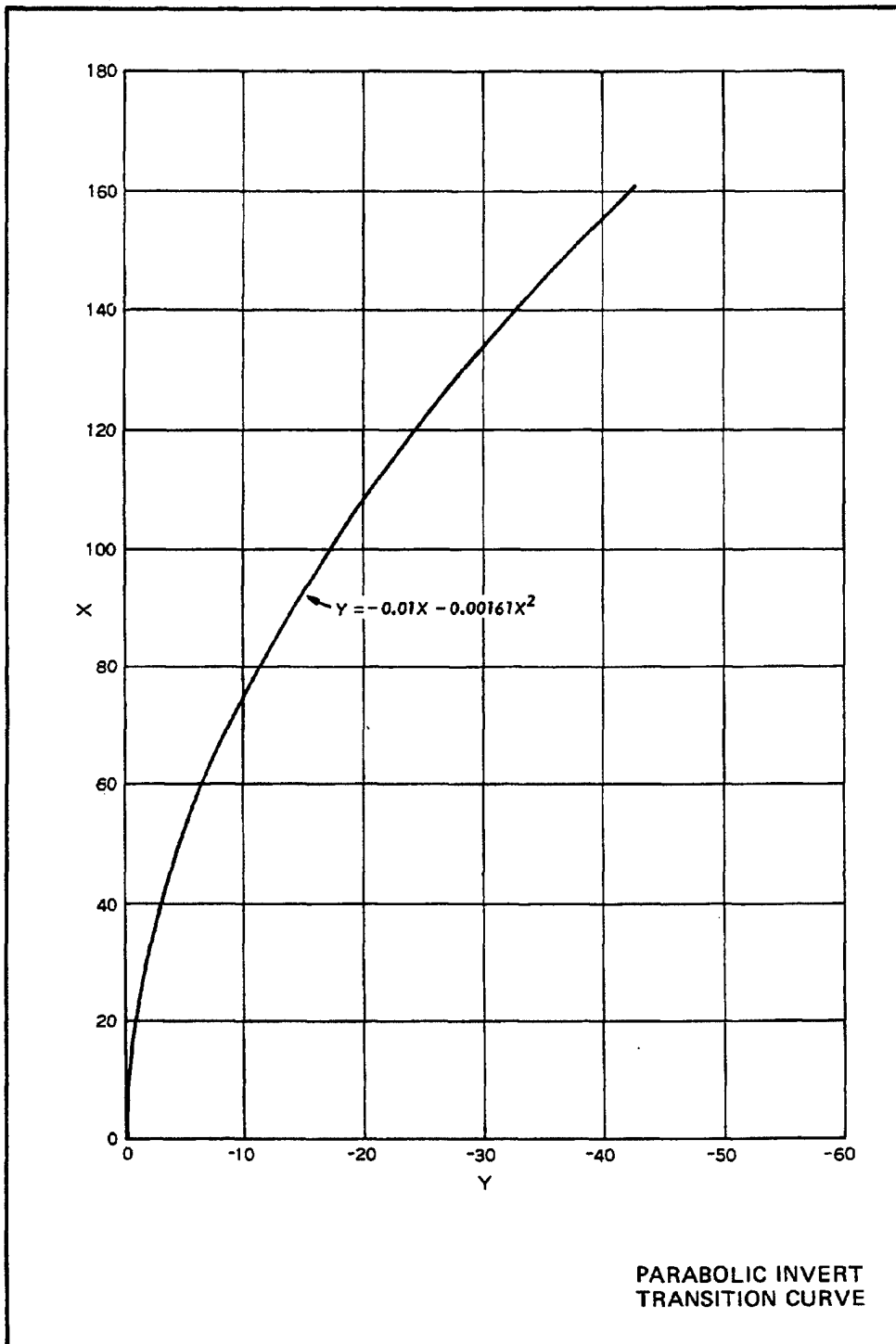
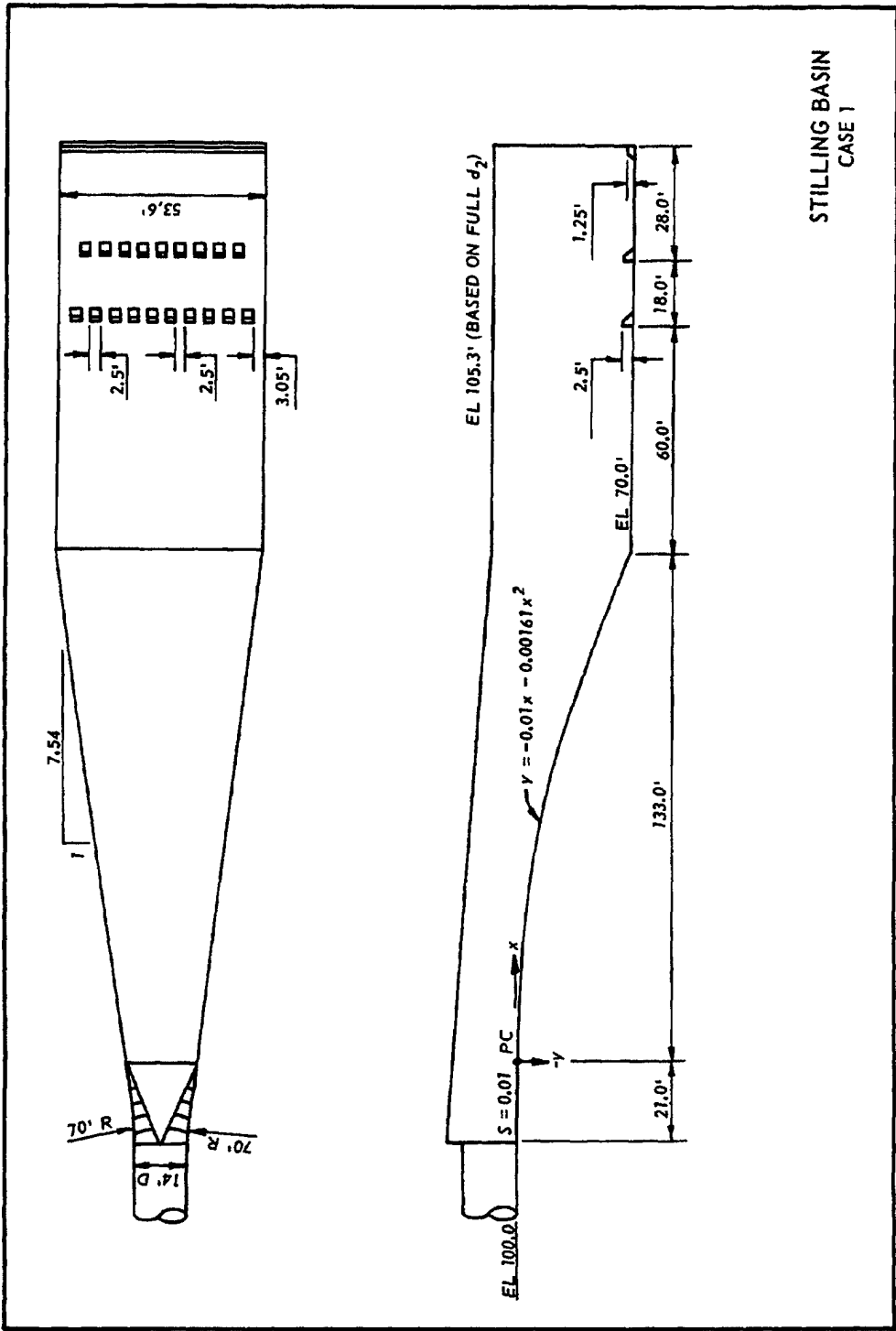

PLATE F-2



STILLING BASIN
 CASE 1

EM 1110-2-1602
15 Oct 80

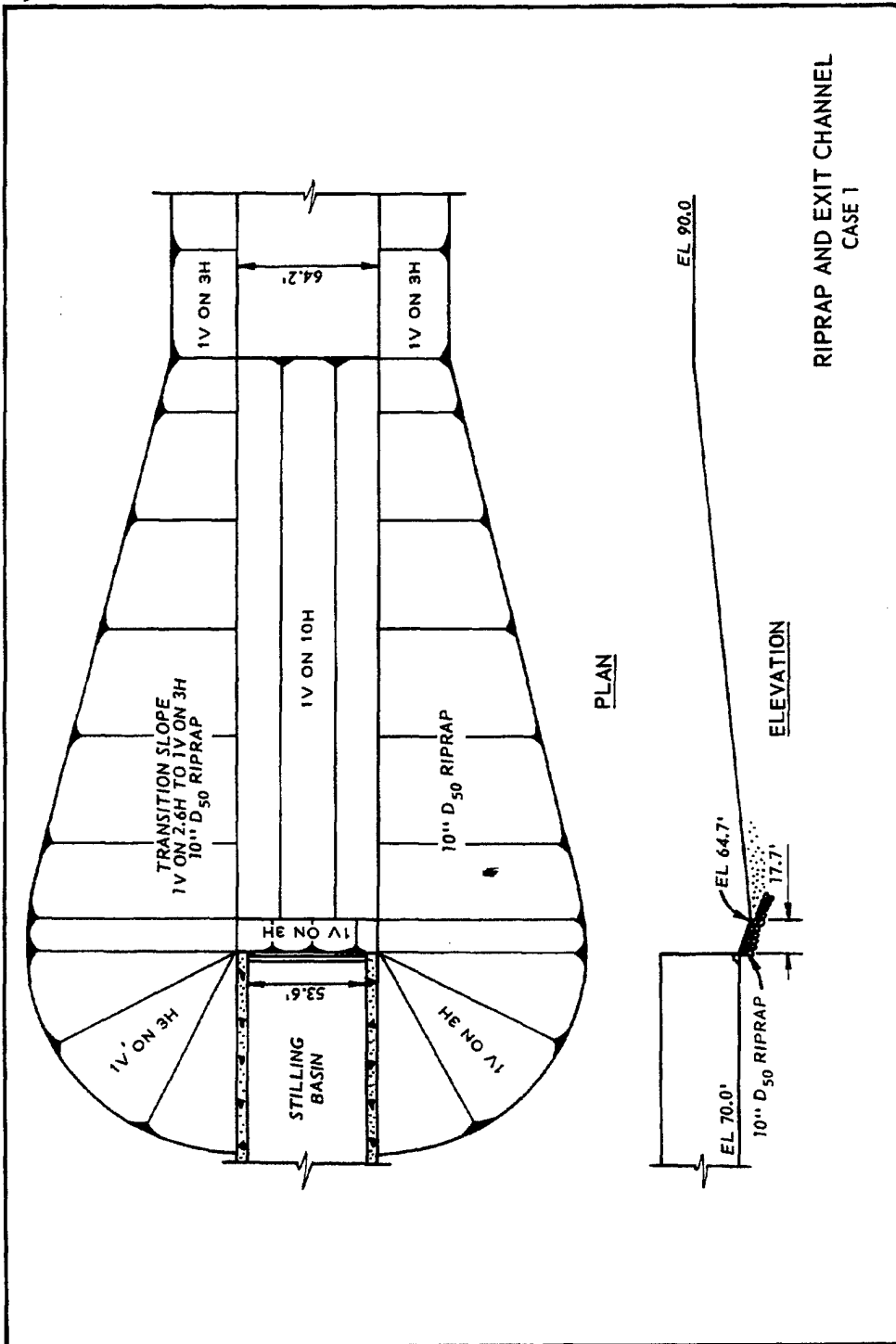
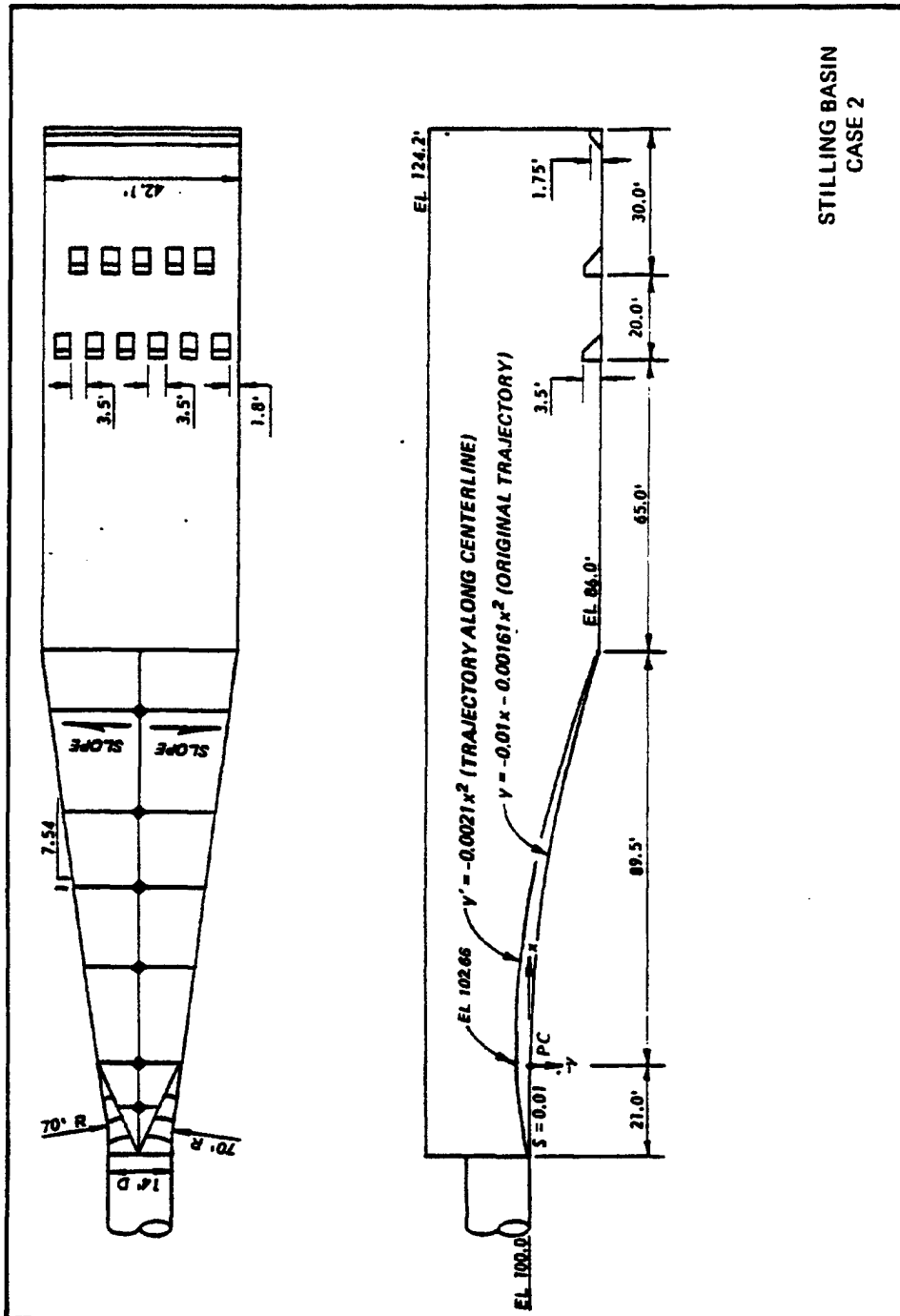

PLATE F-4

EM 1110-2-1602
 Change 1
 15 Mar 87



STILLING BASIN
 CASE 2

PLATE F-5

EM 1110-2-1602
Change 1
15 Mar 87

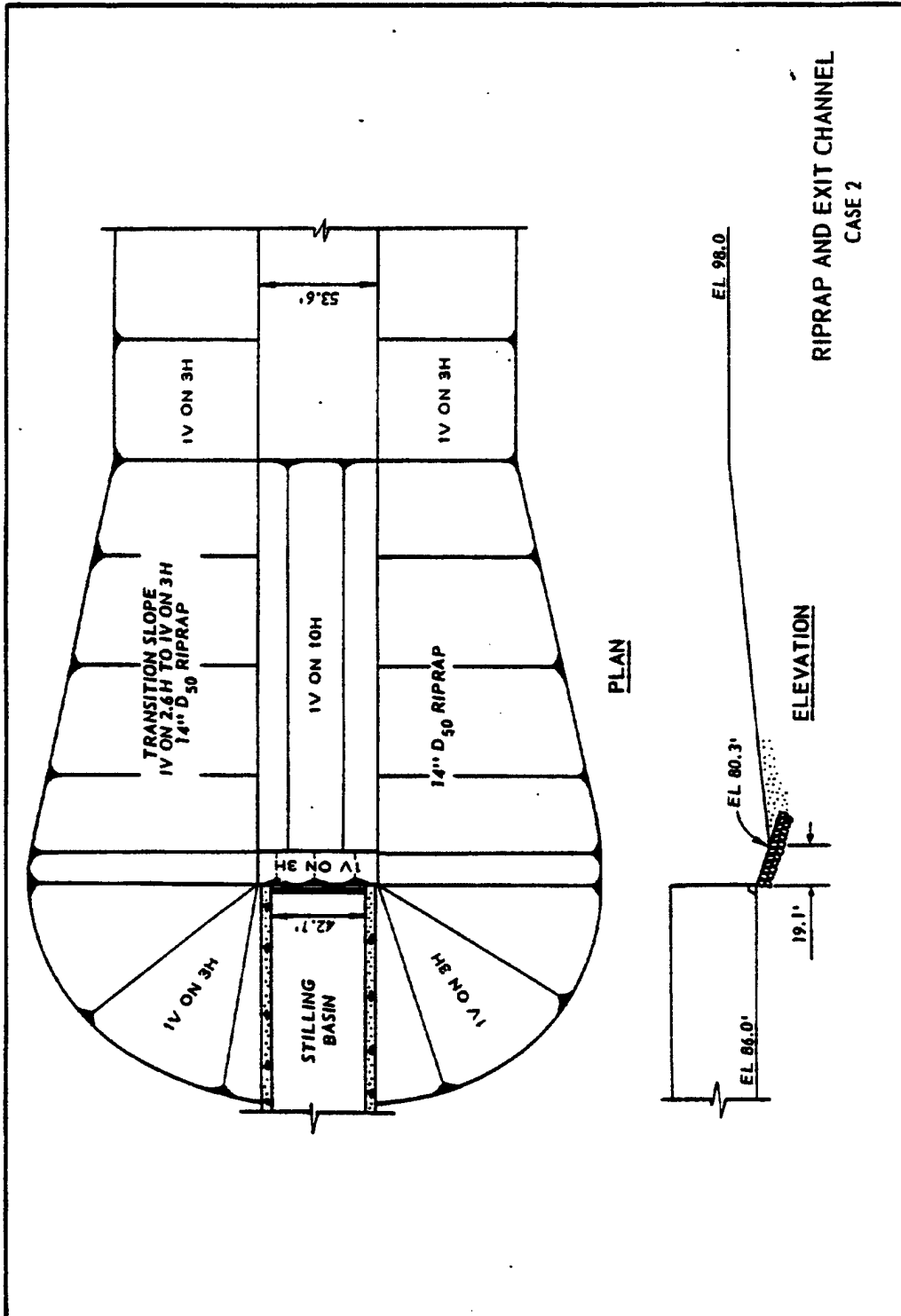

PLATE F-6