

REPORT DOCUMENTATION PAGE

Form Approved
OMB NO. 0704-0188

Public Reporting burden for this collection of information is estimated to average 1 hour per response, including the time for reviewing instructions, searching existing data sources, gathering and maintaining the data needed, and completing and reviewing the collection of information. Send comment regarding this burden estimate or any other aspect of this collection of information, including suggestions for reducing this burden, to Washington Headquarters Services, Directorate for Information Operations and Reports, 1215 Jefferson Davis Highway, Suite 1204, Arlington, VA 22202-4302, and to the Office of Management and Budget, Paperwork Reduction Project (0704-0188), Washington, DC 20503.

1. AGENCY USE ONLY (Leave Blank)		2. REPORT DATE 12 Sept. 2001	3. REPORT TYPE AND DATES COVERED Final, 4 April 2000 - 12 Sept. 2001 12 Jun 00 - 11 Jun 01	
4. TITLE AND SUBTITLE Diode-Based Integrated Circuits for Millimeter and Submillimeter-Wave Identification of Chemical and Biological Agents			5. FUNDING NUMBERS DAAD19-00-1-0404	
6. AUTHOR(S) Robert M. Weikle, II, University of Virginia Thomas W. Crowe, University of Virginia				
7. PERFORMING ORGANIZATION NAME(S) AND ADDRESS(ES) Department of Electrical and Computer Engineering 351 McCormick Road, PO Box 400743 University of Virginia, Charlottesville, VA 22904-4743			8. PERFORMING ORGANIZATION REPORT NUMBER	
9. SPONSORING / MONITORING AGENCY NAME(S) AND ADDRESS(ES) U. S. Army Research Office P.O. Box 12211 Research Triangle Park, NC 27709-2211			10. SPONSORING / MONITORING AGENCY REPORT NUMBER 40679.2-EL P-40679-EL	
11. SUPPLEMENTARY NOTES The views, opinions and/or findings contained in this report are those of the author(s) and should not be construed as an official Department of the Army position, policy or decision, unless so designated by other documentation.				
12 a. DISTRIBUTION / AVAILABILITY STATEMENT Approved for public release; distribution unlimited.			12 b. DISTRIBUTION CODE	
13. ABSTRACT (Maximum 200 words) <p>This final report summarizes efforts to realize a device and sensor technology for the study, detection, and identification of chemical and biological agents at millimeter and submillimeter-wave frequencies. This effort has focused on two goals: (1) the realization of an integrated-circuit technology for Terahertz Schottky diodes and (2) the development of sampled-line reflectometers for measuring the return loss (and consequently, absorption spectra) of chemical and bioagent samples. Schottky diodes represent the most successful device technology for applications in the submillimeter and terahertz region of the electromagnetic spectrum and these devices are the critical components used in most heterodyne receivers and harmonic generators for radio astronomy and atmospheric remote sensing. Integrated planar diodes allow vast improvements in the level of performance of systems that rely on Schottky technology and permit the realization of fully integrated spectrometers and other instruments for chem/bio detection.</p> <p>During the past year and a half of this project, we have developed a beamlead diode processing technology for producing planar chips that can be readily integrated into external circuitry. These discrete diodes will allow rapid prototyping of circuits and systems and permit higher levels of performance by eliminating many of the difficulties associated with manual assembly of hybrid components. In addition, we have developed millimeter and submillimeter-wave reflectometers based on the sampled-line architecture. These reflectometers can be used to measure the complex reflection coefficients (magnitude and phase) of various chemical and biological materials and utilize the planar Schottky device technology previously mentioned.</p>				
14. SUBJECT TERMS Chemical and Biological Agent Detection, Schottky diodes, Network Analyzers, Submillimeter-Waves, Terahertz Technology			15. NUMBER OF PAGES 10	
			16. PRICE CODE	
17. SECURITY CLASSIFICATION OR REPORT UNCLASSIFIED	18. SECURITY CLASSIFICATION ON THIS PAGE UNCLASSIFIED	19. SECURITY CLASSIFICATION OF ABSTRACT UNCLASSIFIED	20. LIMITATION OF ABSTRACT UL	

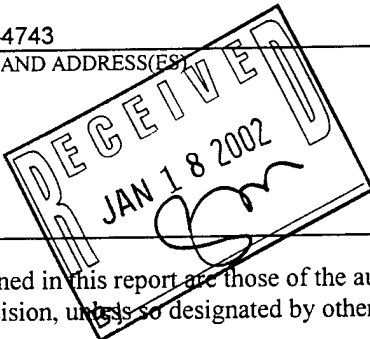

MASTER COPY: PLEASE KEEP THIS "MEMORANDUM OF TRANSMITTAL" BLANK FOR REPRODUCTION PURPOSES. WHEN REPORTS ARE GENERATED UNDER THE ARO SPONSORSHIP, FORWARD A COMPLETED COPY OF THIS FORM WITH EACH REPORT SHIPMENT TO THE ARO. THIS WILL ASSURE PROPER IDENTIFICATION. NOT TO BE USED FOR INTERIM PROGRESS REPORTS; SEE PAGE 2 FOR INTERIM PROGRESS REPORT INSTRUCTIONS.

MEMORANDUM OF TRANSMITTAL

U.S. Army Research Office
ATTN: AMSRL-RO-BI (TR)
P.O. Box 12211
Research Triangle Park, NC 27709-2211

Reprint (Orig + 2 copies)

Technical Report (Orig + 2 copies)

Manuscript (1 copy)

X Final Progress Report (Orig + 2 copies)

X Related Materials, Abstracts, Theses (1 copy)

CONTRACT/GRANT NUMBER: DAAD19-00-1-0404

REPORT TITLE: Diode-Based Integrated Circuits for Millimeter and Submillimeter-Wave Identification of Chemical and Biological Agents

is forwarded for your information.

SUBMITTED FOR PUBLICATION TO (applicable only if report is manuscript):

Sincerely,

Robert M. Weikle, II
Associate Professor
Department of Electrical and Computer Engineering
University of Virginia

20020125 281

REPORT DOCUMENTATION PAGE (SF298)
(Continuation Sheet)

Two primary areas of progress have been made over the past year and a half on this research program. The first is the development of planar Schottky diode fabrication technologies for detectors and sources to be used in spectroscopic instrumentation. The second area of progress is the research and development of a sampled-line analyzer for the measurement of complex reflection coefficients (both magnitude and phase). The sampled-line analyzer uses a relatively simple circuit architecture and will allow our measurement capabilities to be extended beyond W-band and to frequencies approaching 1 THz. This will allow us to measure and accurately characterize the absorption spectra of different chemical and biological samples in the spectral range that is currently difficult to access. The compact and simple design of the instrument makes it amenable to scaling to terahertz frequencies and suitable for use in a non-laboratory environment. Descriptions of our work in these two areas are given below:

Processing Technologies for Planar Integrated Diodes

A major focus on our research is to make terahertz technology practical for U.S. Army applications. One of the major impediments is the present reliance on the soldering of discrete diode chips. The imprecision of handling and soldering microscopic structures creates problems related to reliability, repeatability, and cost. We are developing a beamlead process that will be suitable for application throughout the terahertz frequency band and will help eliminate these difficulties without sacrificing circuit performance.

The student supported on this project is K. Wade Nye. He is working under the direction of Prof. T. Crowe with assistance from W. Bishop. As a team, we have investigated the various processes that are used by industry at microwave frequencies. Based on these, we have identified the following processes for fabricating beamlead diodes for frequencies beyond 100 GHz:

- A beam undercut process that uses a wet GaAs etch to undercut the beams after the diode fabrication is complete. A simple backside etching then released the chip structure from the wafer
- A backside alignment and etching process that uses a masked etch from the back of the wafer to define the chip dimensions after the wafer is lapped to the final chip thickness of 30—40 μ m.
- A front-side process whereby the sides of the chip structure are formed by a wet GaAs etch before the beams are formed. The beams are then formed on the sloped edges of the chip and a careful backside lapping and etching step frees the individual chips.
- A mesa formation and planarization process that uses a wet GaAs etch to form mesas that are then refilled with a temporary material such as epoxy. Then the beam leads are formed, the wafer is lapped to the final chip thickness and the chips are released by dissolving the epoxy.

Each of these processes has benefits and drawbacks. We are continuing to perform trials of each of the key processing steps and have fabricated prototype chip structures. We plan to evaluate these steps and determine the best process based on our existing facilities and the desire to eventually use beam leads for discrete millimeter-wave chips, quartz integrated circuits for 1 THz and above, and membrane chips suspended in waveguide by the beams.

Sampled-Line Analyzers for Millimeter/Submillimeter-Wave Measurements

Scattering parameter measurements based on vector network analysis play a critical role in the design and development of modern microwave components. In fact, scattering parameter measurement techniques are frequently used to study and analyze the properties of dielectrics and other materials as well as quasi-optical

components such as mesh filters. Unfortunately, the size, cost, and complexity of modern network analyzers often preclude their use in non-laboratory environments. In addition, commercial network analyzers are typically limited in operation to W-band (75—110 GHz), with extensions to higher frequencies being both cumbersome and expensive. Over the past several years, a number of investigators have explored alternatives to the traditional four-port architecture of network analyzers based on the vector voltmeter. Much of this work has been motivated by the need to characterize new devices and components that are capable of operating far beyond W-band as well as to measure the properties of materials in the submillimeter-wave range. Because of the relative difficulty in implementing complex or intricate circuit designs at millimeter and submillimeter wavelengths, simple architectures tend to be preferred and generally yield superior performance at frequencies exceeding 100 GHz.

The sampled line analyzer is a relatively simple version of the six-port reflectometer introduced in the 1970s's by Engen. The six-port architecture removes the requirement for a vector voltmeter and the magnitude and phase of an unknown reflection coefficient are determined from an ensemble of four power measurements. In the sampled-line implementation of the six-port reflectometer, the power detectors are diodes that sample the standing wave at discrete points along a section of transmission line. As a result, the sampled-line analyzer is reminiscent of the slotted-line that is commonly used for waveguide reflection coefficient measurements.

Over the past year and a half, we have developed two sampled-line analyzers as proof-of-principle demonstrations operating in both the millimeter (W-band) and submillimeter-wave (270—285 GHz) regions. These analyzers are fully described in the following attached documents:

1. S. Ilker, R.M. Weikle, I, "A Millimeter-Wave Six-Port Reflectometer Based on the Sampled-Transmission Line Architecture," *IEEE Microwave and Wireless Components Lett.*, vol. 11, no. 8, pp. 340-342, August 2001
2. S. Ilker, R.M. Weikle, II, "A Sampled-Line Reflectometer for Submillimeter-Wave Measurements," submitted to the *2001 MTT-S Int. Microwave Symposium*, Seattle, WA June 2002.

A Millimeter-Wave Six-Port Reflectometer Based on the Sampled-Transmission Line Architecture

Sadık Ülker, *Student Member, IEEE* and Robert M. Weikle, II, *Member, IEEE*

Abstract— This letter presents a proof-of-concept implementation of a millimeter-wave reflectometer for measuring complex reflection coefficients. The reflectometer is based on the six-port architecture and consists of a single section of WR-10 rectangular waveguide and a set of three Schottky power detectors. Design considerations as well as measurements in the 75 to 110 GHz range are described and discussed. Because of its simple architecture, the reflectometer is amenable to scaling for measurements well into the submillimeter-wave region of the spectrum.

Keywords— Network analyzers, six-port reflectometers, Schottky detectors.

I. INTRODUCTION

SCATTERING PARAMETER measurements based on vector network analysis play a critical role in the design and development of modern microwave components. In fact, scattering parameter measurement techniques are frequently used to study and analyze the properties of dielectrics and other materials [1] as well as quasi-optical components such as mesh filters [2]. Unfortunately, the size, cost, and complexity of modern network analyzers often preclude their use in non-laboratory environments. In addition, commercial network analyzers are typically limited in operation to W-band (75-110 GHz), with extensions to higher frequencies being both expensive and cumbersome [3].

Over the past several years, a number of investigators have explored alternatives to the traditional four-port network analyzer based on the vector voltmeter [2,4-6]. Much of this work has been motivated by the need to characterize new devices and components that are capable of operating far beyond W-band as well as to measure the properties of materials in the submillimeter-wave range. Because of the relative difficulty in implementing complex or intricate circuit designs at millimeter and submillimeter wavelengths, simple architectures tend to be preferred and generally yield superior performance at frequencies exceeding 100 GHz.

In this paper, we present a proof-of-concept six-port reflectometer for millimeter-wave measurements that is based on the sampled-transmission line architecture first proposed and demonstrated by Williams [7]. Because of its simple structure, the sampled-line reflectometer has outstanding potential for being scaled to the submillimeter-wave region of the spectrum.

The authors are with the School of Engineering and Applied Science, University of Virginia, Charlottesville, VA 22904, U.S.A.

This work was supported by the U.S. Army Research Office under grants DAAG55-98-1-0489 and DAAD19-00-1-0404.

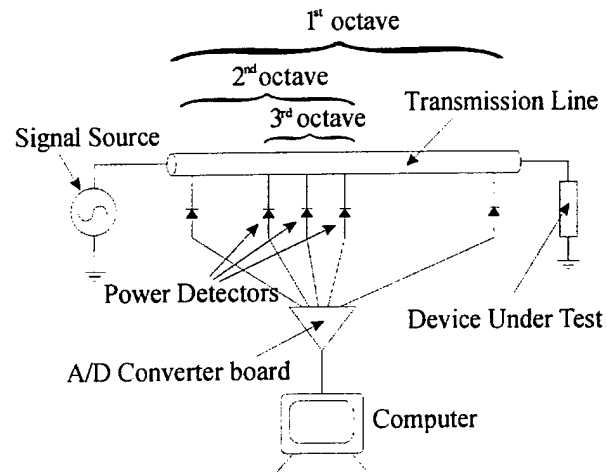

Fig. 1. Basic structure of the sampled-transmission line six-port reflectometer (based on [7]). A set of power detectors samples the voltage standing wave along a section of transmission line.

II. REFLECTOMETER DESIGN

The sampled-line analyzer (shown in figure 1) is a relatively simple version of the six-port reflectometer introduced by Engen [8,9]. The six-port architecture removes the requirement for a vector voltmeter and the magnitude and phase of an unknown reflection coefficient are determined from an ensemble of four power measurements. In the sampled-line implementation of the six-port reflectometer, the power detectors are diodes that sample the voltage standing wave at discrete points along a section of transmission line. As a result, the sampled-line reflectometer is reminiscent of the standard slotted-line used to measure standing waves in waveguide.

It has been shown that only three power detectors are required for the sampled-line architecture if the load being measured is known to be passive [7,8]. Effectively, this reduces the sampled-line analyzer to a five-port reflectometer. To eliminate aliasing, the standing-wave voltages along the transmission line are sampled at intervals not exceeding a half-wavelength. Consequently, a triplet of diode detectors spaced by $\lambda/6$ will allow the reflection coefficient to be measured over an octave of bandwidth (see figure 1).

A diagram of the millimeter-wave reflectometer investigated in this work is shown in figure 2(a). The circuit consists of a 5 cm long section of WR-10 waveguide (with inner dimensions of 2.54 mm \times 1.27 mm) and three microstrip-to-waveguide probes spaced 700 μm ($\lambda_g/6$ at 92.5 GHz) apart. The waveguide probes are fabricated on 125 μm

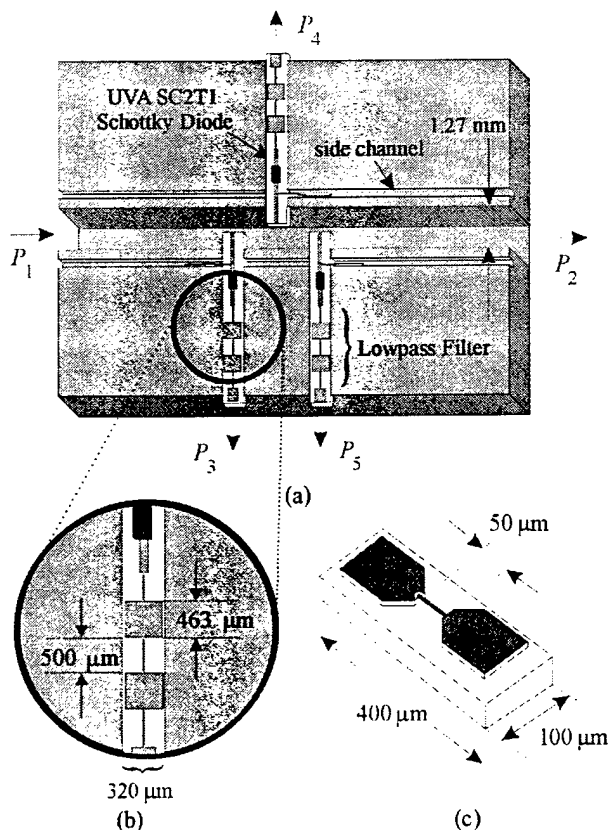

Fig. 2. (a) Diagram of the W-band sampled-line reflectometer. Shallow side channels parallel to the waveguide accommodate wirebond connections for dc return-to-ground. (b) Close-up view of the quartz microstrip probe and low-pass filter section. (c) Diagram of the UVA SC2T1 planar Schottky diode chip.

thick quartz substrates and lie in shallow cross channels as shown in figure 2. UVA SC2T1 planar Schottky diodes fabricated at the University of Virginia, shown in figure 2(c), are flip-chip mounted across $250 \mu\text{m}$ wide gaps in the microstrip circuits. These diodes, which are typically used for mixer applications at submillimeter wavelengths, are used as square-law detectors that sample the magnitude of the electric field at three points along the waveguide. $\lambda_0/4$ -long bond wires shorted to the waveguide housing provide dc return and the detector outputs are measured with a set of Keithley-2000 $6\frac{1}{2}$ -digit multimeters. Five-section stepped-impedance microstrip low-pass filters (with high impedance sections of 145Ω and low impedance sections of 48Ω) block the millimeter-wave signal from propagating to the detection circuitry.

III. CALIBRATION PROCEDURE

As with all six-port reflectometers, calibration of the sampled-line reflectometer consists of two steps. In the initial step, the six-port network is converted to an equivalent four-port reflectometer. The details of this procedure are well-documented and will not be repeated here [8,10]. The six-port to four-port conversion involves finding five calibration constants that are a property of the network

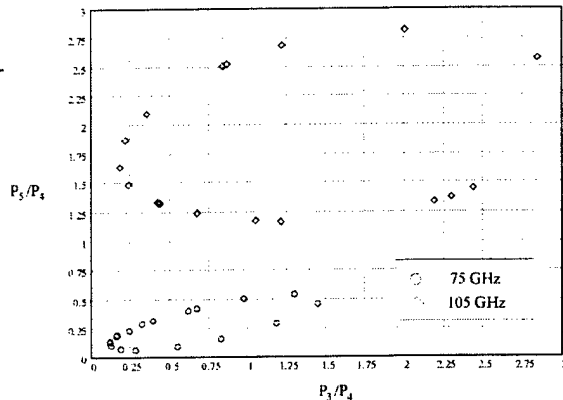

Fig. 3. Plot of the detected power ratios P_5/P_4 vs. P_3/P_4 for the sampled-line reflectometer at various sliding backshort positions. Data is shown for both 75 GHz and 105 GHz. A least-squares fit to the ellipses provides the calibration constants for the six-port to four-port conversion.

architecture [8]. This calibration step is most easily accomplished using a sliding termination. With P_3 , P_4 and P_5 denoting the measured outputs of the three power detectors (see figure 2), Engen has shown that the sliding termination traces out an ellipse in the P_5/P_4 - P_3/P_4 plane [10]. A least-squares fit to the data allows the five calibration constants to be determined.

A plot of the calibration ellipses at 75 and 105 GHz for the W-band sampled-line reflectometer is shown in figure 3. For measurements throughout the 75–110 GHz range, sliding short measurements were taken using a noncontacting WR-10 tunable backshort (Millitech TSC-10-R000) and the calibration constants were determined for each frequency point of interest by least-squares fitting to the measured data.

The second step of the calibration procedure consists of the familiar technique of using three well-characterized standard loads to determine the error coefficients in the four-port reflectometer model. In this work, WR-10 calibration standards (a matched termination, a short, and an offset short) from the HP W11644A calibration kit were used for this step.

IV. MEASUREMENTS

The sampled line reflectometer illustrated in figure 2 was evaluated using a variety of different loads and comparing the measured reflection coefficients with those obtained with an HP 8510C millimeter-wave vector network analyzer. The basic measurement setup is shown in figure 4. A variable attenuator placed at the reflectometer input allows the input power to be adjusted appropriately so that the Schottky detectors operate in the square-law region. A second, fixed attenuator (3 dB) is placed between the reflectometer and load being measured. This output attenuator eliminates the deep standing-wave nulls that occur when the reflectometer is connected to a load with reflection coefficient magnitude close to unity. Small errors in measuring the magnitude of these nulls can result in significant uncertainty in the resulting calculated reflection

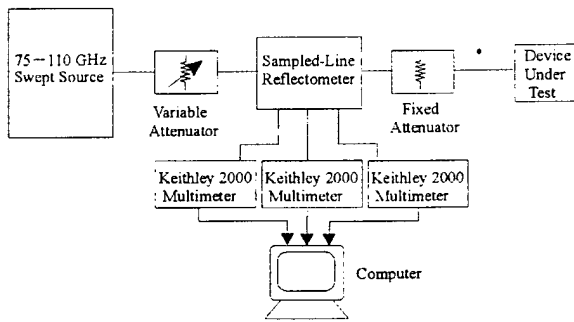

Fig. 4. Measurement setup for the W-band sampled-line reflectometer. The output of an HP8510C millimeter-wave network analyzer is used for the swept source.

coefficient.

Figure 5 shows return loss (s_{11}) measurements made for a WR-10 E-plane, H-plane waveguide tuner (Milltech EHT-10-R000). Because of its large variation in return loss magnitude and phase over the 75 GHz to 110 GHz range, the tuner provides a reasonable test on the performance of the sampled-line reflectometer. The input power level used for these measurements was typically less than $300 \mu\text{W}$ and the detector diodes were forward biased to 0.08 mA. Figure 5 shows that the return loss measured using the sampled-line reflectometer compares relatively well to that obtained from an HP 8510C network analyzer over the entire WR-10 waveguide band, with the largest discrepancy occurring in the 81–84 GHz range. Over this frequency band the measured output of the detectors was near the noise floor of our measurement system, resulting in larger errors in the calculated reflection coefficient. This behavior suggests poor RF coupling between the waveguide and diodes in the 81–84 GHz band and is likely due, in part, to misalignments associated with manual assembly of the reflectometer.

V. SUMMARY

This letter has described a proof-of-concept demonstration of a millimeter-wave reflectometer based on the six-port network architecture. The reflectometer design and performance over the 75 to 110 GHz range have been presented and discussed. Because it consists of only a single section of waveguide and a set of Schottky power detectors, the reflectometer is amenable to scaling to much higher frequencies. Future work will focus on extending this technique to the submillimeter range where diagnostic and test instrumentation is both expensive and scarce.

ACKNOWLEDGMENTS

The authors are grateful for the advice and assistance of Professors Tom Crowe and Jeffrey Hesler at the University of Virginia.

REFERENCES

- [1] H.E. Bussey "Measurement of RF properties of materials: a survey," *Proc. of the IEEE*, vol. 55, pp. 1046–1053, 1967.

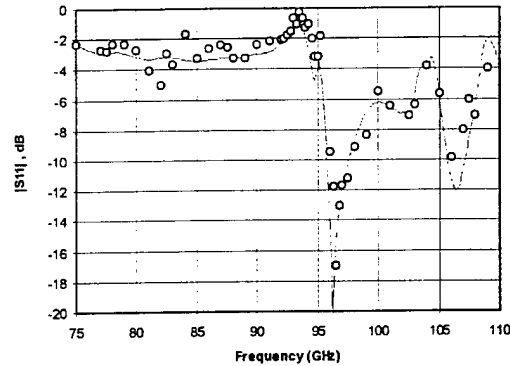

(a)

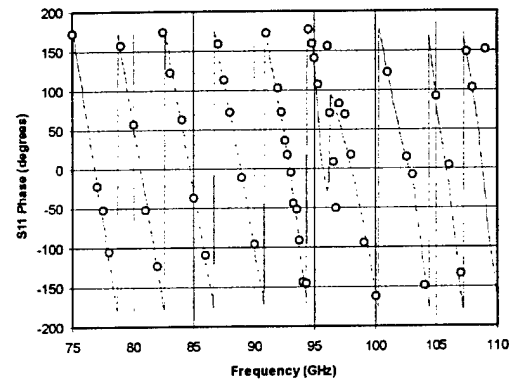

(b)

Fig. 5. (a) Magnitude (in dB) of s_{11} for a waveguide E-plane, H-plane tuner. (b) Phase of s_{11} for the E-plane, H-plane tuner. Both plots show data measured using the sampled-line reflectometer (—) and the HP 8510C millimeter-wave network analyzer (—) for comparison.

- [2] A. Roberts and R.C. Compton, "A vector measurement scheme for testing quasi-optical components," *Int. J. of Infrared and Millimeter Waves*, vol. 11, no. 2, pp. 165–174, 1990.
- [3] "Using the OML millimeter wave vector network analyzer frequency extension modules with the HP 8510 vector network analyzer," *OML HP 8510 Millimeter Application Note*, Oleson Microwave Laboratories, 355 Woodview Dr., Suite 300, Morgan Hill, CA 95037.
- [4] Y. Konishi, M. Kamegawa, M. Case, R. Yu, S.T. Allen, M.J.W. Rodwell, "A broadband free-space millimeter-wave vector transmission measurement system," *IEEE Trans. Microwave Theory Tech.*, vol. MTT-42, no. 7, pp. 1131–1139, July 1994.
- [5] U. Stumper, "A simple multiport reflectometer using fixed probes and an adjustable attenuator," *Proc. 11th European Microwave Conference*, pp. 622–626, 1981.
- [6] G. Hjiipieris, R.J. Collier, and E.J. Griffin, "A millimeter-wave six-port reflectometer using dielectric waveguide," *IEEE Trans. Microwave Theory Tech.*, vol. MTT-38, no. 1, pp. 54–61, January 1990.
- [7] W.L. Williams, *Computer-Aided Measurement of Microwave Circuits*, Ph.D. thesis, California Institute of Technology, 1989.
- [8] G.F. Engen, "The six-port reflectometer: an alternative network analyzer," *IEEE Trans. Microwave Theory Tech.*, vol. MTT-25, no. 12, pp. 1075–1080, December 1977.
- [9] G.F. Engen, "An improved circuit for implementing the six-port technique of microwave measurements," *IEEE Trans. Microwave Theory Tech.*, vol. MTT-25, pp. 1080–1083, December 1977.
- [10] G.F. Engen, "Calibrating the six-port reflectometer by means of sliding terminations," *IEEE Trans. Microwave Theory Tech.*, vol. MTT-26, no. 12, pp. 951–957, December 1978.

A Sampled-Line Reflectometer for Submillimeter-Wave Measurements

Sadık Ülker, *Student Member, IEEE* and Robert M. Weikle, II, *Member, IEEE*

Abstract— A reflectometer designed for operation at submillimeter wavelengths and based on the sampled-transmission line architecture is described. The reflectometer is a relatively simple implementation of the six-port network analyzer introduced by Engen and consists of a section of rectangular waveguide and an ensemble of Schottky diode power detectors. Design considerations for the instrument are described and measurements in the 270 GHz to 285 GHz range are presented and discussed.

Keywords— Six-port network analyzers, submillimeter-wave systems, reflectometers, Schottky diodes.

I. INTRODUCTION

THE TEST AND measurement infrastructure that has played such a pivotal role in the development of microwave and millimeter-wave systems is either scarce, expensive and complex, or does not exist for much of the submillimeter-wave region. This is unfortunate because the submillimeter-wave spectrum has long been recognized as a fruitful region for fundamental research, particularly in radio astronomy [1], atmospheric remote sensing [2] and molecular spectroscopy. More recently, scientists and engineers have begun to recognize the potential of submillimeter systems in applications ranging from scaled radar range measurements to the detection and monitoring of chemical and biological warfare agents [3]. Because of the importance of these and other applications, a significant effort has been focused on developing electronics capable of operating at submillimeter wavelengths. Still, the limited availability of diagnostic instrumentation remains a major obstacle limiting full use and exploration of the submillimeter portion of the electromagnetic spectrum.

The lack of instrumentation for measuring scattering-parameters in the submillimeter region has prompted a number of investigators to explore methods for extending traditional four-port analyzers to higher frequencies [4,5] as well as finding alternative network analyzer architectures [6,7]. An attractive technique for realizing a submillimeter-wave *s*-parameter measurement system is based on the six-port reflectometer proposed and developed by Engen [8,9]. In this paper, we present a submillimeter-wave implementation of the six-port reflectometer based on a sampled-transmission line structure. Design considerations and calibration of the instrument are discussed and measurements over the 270–285 GHz band are presented.

The authors are with the School of Engineering and Applied Science, University of Virginia, 351 McCormick Road, Charlottesville, VA 22904-4743, U.S.A.

This work was supported by the U.S. Army Research Office under grant DAAD19-00-1-0404 and the Multi-disciplinary University Research Initiative (MURI) Program. Funding was also provided by the Virginia Center for Innovative Technology.

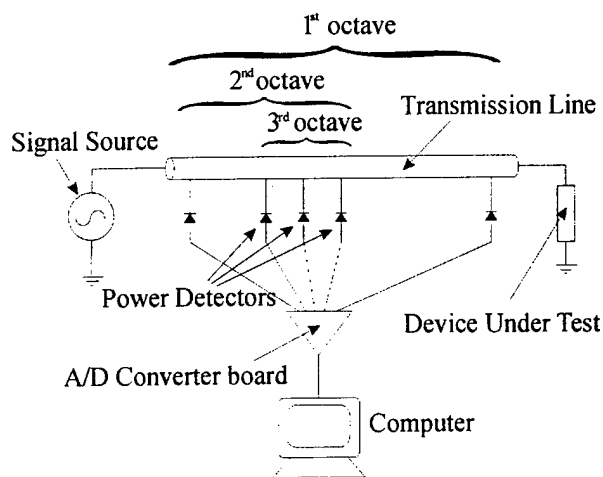

Fig. 1. Basic architecture of the sampled-transmission line six-port reflectometer (based on the work of Williams [11]). A set of power detectors samples the standing wave on the section of transmission line.

II. BACKGROUND

The sampled-line analyzer was introduced by Williams [10] and is a relatively simple version of the six-port reflectometer. The basic instrument, shown in figure 1, consists of a single section of transmission line and an ensemble of power detectors. The detectors sample the standing wave at discrete points along the transmission line and the error-corrected reflection coefficient is computed from power measurements through a bilinear transformation.

It has been shown that only three power detectors are required if the load being measured is known to be passive [8,10]. Effectively, this a priori knowledge (which is nearly always valid at submillimeter wavelengths) reduces the six-port analyzer to a five-port reflectometer. To eliminate aliasing, the standing wave along the transmission line is sampled at intervals not exceeding a half-wavelength. Consequently, a triplet of detectors spaced by $\lambda_g/6$ (where λ_g is the guide wavelength) will permit reflection coefficient measurements of passive loads over an octave bandwidth. The operating range of the instrument can be extended to several octaves by adding extra power detectors as shown in figure 1.

As with all six-port reflectometers, calibration of the sampled-line analyzer consists of two steps. In the initial calibration step, the six-port network is converted to an equivalent four-port reflectometer. This conversion, which involves finding five calibration constants that are a property of the network architecture, is most easily accom-

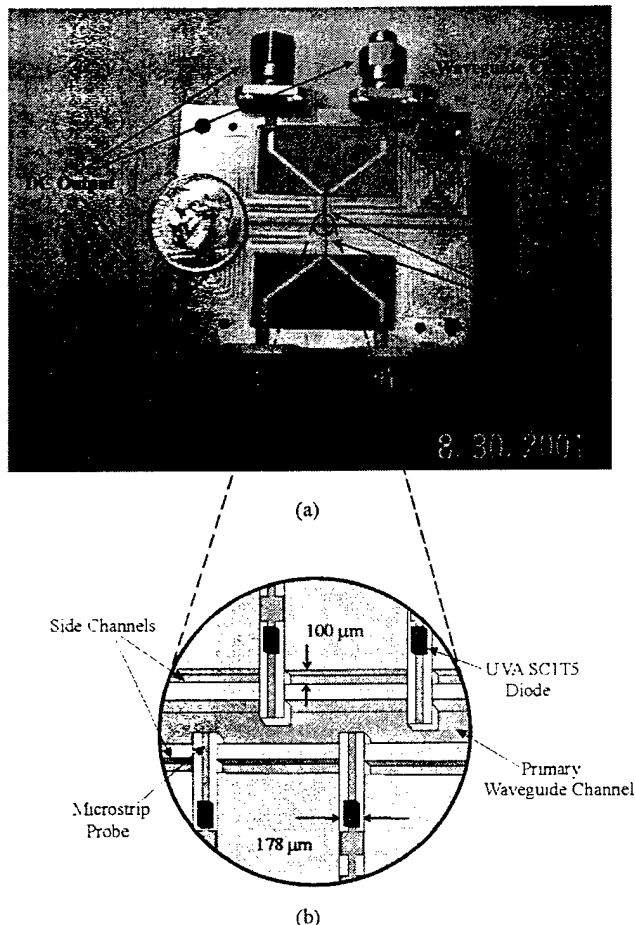

Fig. 2. (a) Photograph of the submillimeter sampled-line reflectometer. (b) Diagram showing details of the microstrip probes and waveguide channels.

plished using a sliding termination. Details of this procedure are well-documented [11] and will not be repeated here. The second part of the calibration consists of the familiar technique of using three well-characterized standards to determine the error coefficients in the four-port reflectometer model. The extra calibration step required for six-port reflectometers can be inconvenient. However, the vast simplification in circuit hardware that results from the six-port architecture is often worth the inconvenience, particularly at submillimeter wavelengths where complex or intricate circuit designs are difficult to realize.

III. DESIGN

The sampled-line reflectometer investigated in this work consists of a 5 cm section of rectangular waveguide and a set of four Schottky detector diodes. A photograph of the reflectometer is shown in figure 2(a). The waveguide has inner dimensions of $406 \mu\text{m} \times 787 \mu\text{m}$, resulting in single mode propagation over the 190 GHz to 370 GHz band. Shallow ($125 \mu\text{m}$ deep \times $178 \mu\text{m}$ wide) cross channels are machined in the block to accommodate microstrip probes for sampling the standing wave inside the guide. The probe spacing is $195 \mu\text{m}$, corresponding to $\lambda_g/6$ at 320 GHz. In addition,

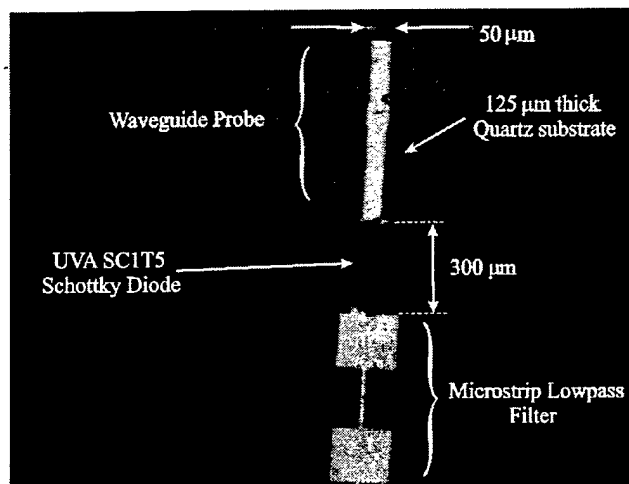

Fig. 3. Photograph of a UVA SC1T5 Schottky diode flip-chip mounted to a microstrip probe. The substrate is $125 \mu\text{m}$ thick quartz.

tion, two narrow ($100 \mu\text{m}$ wide) side channels are machined parallel to the primary waveguide channel (see figure 2(b)). These side channels accommodate quarter wave ($\lambda_0/4$) long bond wires that are used as dc returns-to-ground for the Schottky power detectors. The entire waveguide block was fabricated by Custom Microwave, Inc. and was designed with waveguide flanges that mate to standard WR-3 components.

Sampling probes and microstrip lowpass filters for the reflectometer were designed with the use of Ansoft's *High Frequency Structure Simulator*. To minimize perturbations to the standing wave being sampled, each probe was designed to couple no more than 5% of the energy in the guide to the detectors. The probes and filters were fabricated photolithographically on $125 \mu\text{m}$ thick quartz substrates. SC1T5 planar Schottky diodes fabricated at the University of Virginia were then flip-chip mounted onto these probes using silver epoxy. These devices are typically used for mixer applications at 600 GHz. A photograph of one of the probe circuits is shown in figure 3.

Commercial calibration standards are not readily available at frequencies significantly higher than 100 GHz. Consequently, a set of custom-designed standards were fabricated along with the reflectometer waveguide housing. These standards consisted of a short-circuit termination or "plug" and two offset shims of lengths 33 mils and 37 mils. The shims, and their combination (70 mils long), are used to realize three offset short-circuits. These loads provide a set of standards that can be used to calibrate the reflectometer over the entire 270 GHz to 360 GHz band.

IV. MEASUREMENTS

The experimental setup for the sampled-line reflectometer is shown in figure 4. A mechanically tunable 70 GHz to 105 GHz Gunn diode oscillator (Carlstrom H208) with output isolator is used as the source. This is followed by a broadband frequency tripler (model WR-3.4-X3-LP) designed by Virginia Diodes, Inc. [12]. An adjustable atten-

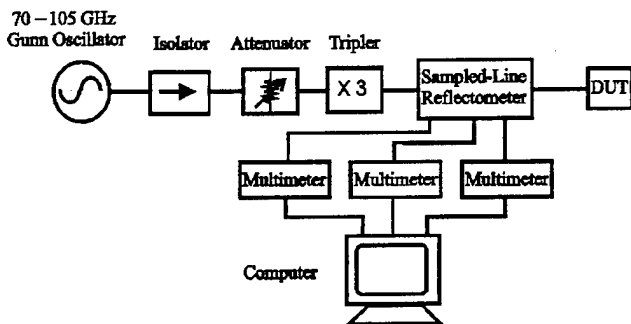

Fig. 4. Experimental setup of the sampled-line reflectometer for measurements in the 270 GHz to 285 GHz range.

uator placed after the isolator permits control of the input power provided to the tripler and reflectometer. The typical output power of the tripler at 280 GHz is 300 μ W. DC bias is supplied to the Schottky detectors with commercial bias supplies (model E3610A by Hewlett Packard) and the output current of the detectors is monitored with a set of Keithley-2000 6 $\frac{1}{2}$ digit multimeters.

A. System Calibration

The first step in calibrating the sampled-line reflectometer consists of converting the six-port analyzer to an equivalent four-port by use of a sliding termination. The sliding short used in this work was designed in-house using a commercially available micrometer with a custom-machined fitting. This fitting (shown in figure 5) consists of a cylindrical brass shim of length 1.8 cm and diameter 356 μ m. The shim slides into a waveguide adaptor (also shown in figure 5) to act as a sliding load. The complete assembly for the backshort is shown in figure 5.

With P_3 , P_4 , and P_5 denoting the powers measured at three of the six-port's detectors, Engen has shown that a sliding termination traces out an ellipse in the $P_3/P_5 - P_4/P_5$ plane [11]. Sliding load measurements taken with the sampled-line reflectometer investigated in this work are shown in figure 6. By least-squares fitting an ellipse to the data at each frequency point, the five six-port calibration constants can be determined [11].

The second calibration step for the reflectometer consists of using three well-characterized standards to determine the complex coefficients for the standard one-port error model. In this work, the custom-made short circuit and two offset shorts previously described were used for this calibration step.

B. Waveguide Measurements

Initial measurements performed on the system indicated that above 285 GHz, the output power of the tripler was insufficient to be measured by the Schottky detectors. In addition, above 300 GHz, two of the detectors exhibited very low responsivities, near the noise floor of our measurement system. It is quite possible that this behavior is a result of misalignment and other imperfections resulting from manual assembly of the reflectometer. Consequently,

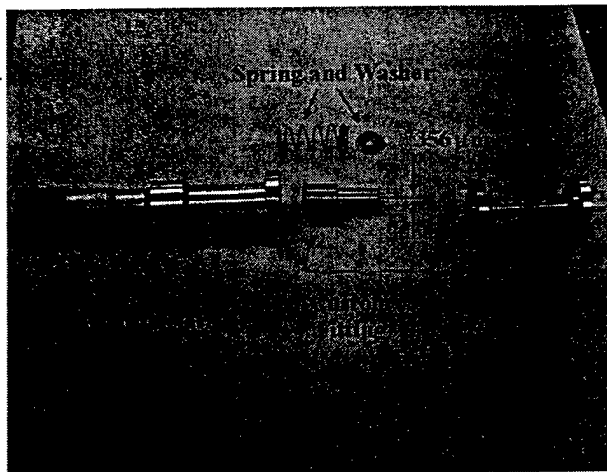

Fig. 5. Photograph of the sliding backshort assembly. This tunable short was used in the six-port calibration procedure.

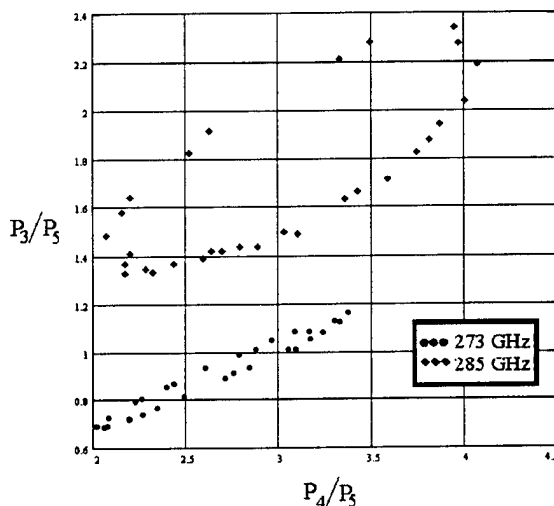

Fig. 6. Measured "calibration ellipses" for the sampled-line reflectometer at 273 GHz (\bullet) and 285 GHz (\diamond). A least-squares fit to the data provides the calibration coefficients for the six-port to four-port conversion.

scattering parameter measurements with the instrument were performed in the 270 GHz to 285 GHz range.

Verification standards are unavailable for submillimeter-wave frequencies and, as a result, operation of the reflectometer was evaluated using the offset shorts designed for calibration. Because only two offset shorts (of lengths 33 mils and 37 mils) are used in the calibration procedure for the 270 GHz to 285 GHz range, the third offset (70 mils) can be used as a check to verify the reflectometer is working properly. Remeasurement of the standards used for calibration can provide information regarding the repeatability of measurements.

Figure 7 shows the measured phase of s_{11} for the three offset shorts over the 270 GHz-285 GHz band. The measured phase is close to that predicted using an ideal, lossless short-circuited waveguide as a model and follows the

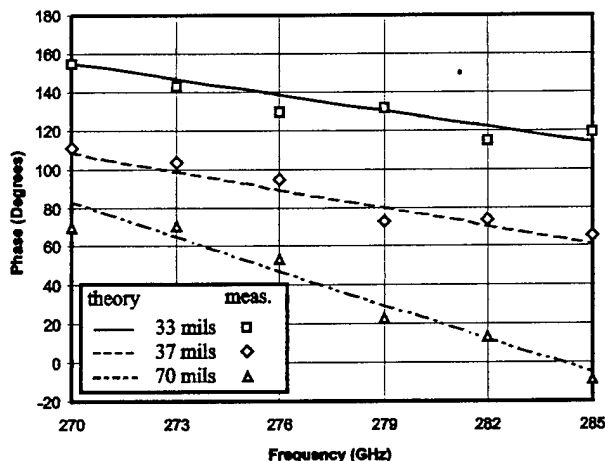

Fig. 7. Measured phase vs. frequency for three offset short circuits.

expected slope as a function of frequency. It should be noted that no waveguide losses are accounted for in either the theoretical curves or circuit models used for the calibration standards. In addition, there is approximately a ± 5 uncertainty in the phase measurements arising from use of the Gunn diode source. This uncertainty arises from frequency drift of the device as well as small errors in adjusting the micrometers used for frequency tuning.

Because the loads measured in figure 7 are ideally lossless, the magnitude of the reflection coefficient is expected to be near 0 dB. Magnitude measurements performed on the offset shorts are shown in figure 8. In general, the measurements for each shim average near the expected 0 dB, but some data deviate substantially, showing significant error in the calibration. Sources of this error may include imprecise modeling of the calibration standards, repeatability in connecting the waveguide flanges, and the low power levels used for the measurements. Magnitude measurements, in particular, are relatively sensitive to variations in power level and waveguide losses. The phase response, on the other hand, depends primarily on the delay between the measurement reference plane and the load. This is known with good precision for the offset shorts and probably explains why the phase measurements shown above are relatively close to that expected from theory.

V. DISCUSSION

In this paper we have presented and demonstrated a six-port reflectometer for scattering parameter measurements in the submillimeter region. Because the instrument relies only on fundamental submillimeter components (transmission lines and Schottky detectors) and a simple architecture, it can be scaled in principle to frequencies approaching 1 THz. Future work will focus on improvements in the system calibration, extension of the instrument's frequency range, and incorporation of monolithic processing technologies to produce an integrated instrument. In addition, the reflectometer will benefit from improvements in submillimeter-wave source technology.

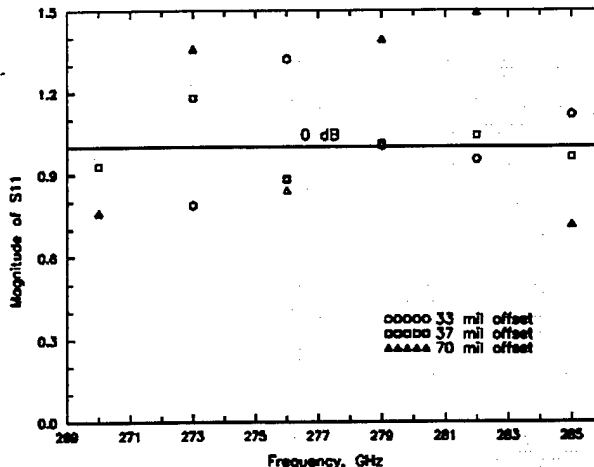

Fig. 8. Measured magnitude vs. frequency for three offset short circuits. Also shown is the 0 dB reference for lossless terminations.

ACKNOWLEDGMENTS

The authors are grateful to Prof. T. Crowe and Prof. J. Hesler at the University of Virginia for providing diodes and much helpful advice for this project.

REFERENCES

- [1] T.G. Phillips and J. Keene, "Submillimeter astronomy," *Proc. of the IEEE*, vol. 80, no. 11, pp. 1662-1678, Nov. 1992.
- [2] J.W. Waters, "Submillimeter-wavelength heterodyne spectroscopy and remote sensing of the upper atmosphere," *Proc. of the IEEE*, vol. 80, no. 11, pp. 1679-1701, Nov 1992.
- [3] N. Gopalsami and A.C. Raptis, "Millimeter-wave radar sensing of airborne chemicals," *IEEE Trans. on Microwave Theory and Tech.*, vol. MTT-49, no. 4, pp. 646-653, April 2001.
- [4] P. Goy, M. Gross, and J.-M. Raimond, *15th Int. Conf. on Infrared and Millimeter Waves*, Orlando, FL, SPIE 1576, 487 (1990).
- [5] 355 Woodview Dr., Suite 300, "Using the OML millimeter wave vector network analyzer frequency extension modules with the HP 8510 vector network analyzer," in *OML HP 8510 Millimeter Application Note*. Morgan Hill, CA 95037: Oleson Microwave Laboratories.
- [6] Y. Konishi, M. Kamegawa, M. Case, R. Yu, S.T. Allen, and M.J.W. Rodwell, "A broadband free-space millimeter-wave vector transmission measurement system," *IEEE Trans. on Microwave Theory and Tech.*, vol. MTT-42, no. 7, pp. 1131-1139, July 1994.
- [7] U. Stumper, "A simple multiport reflectometer using fixed probes and an adjustable attenuator," in *Proc. 11th Eur. Microwave Conf.*, 1981, pp. 622-626.
- [8] G.F. Engen, "The six-port reflectometer: an alternative network analyzer," *IEEE Trans. Microwave Theory Tech.*, vol. MTT-25, no. 12, pp. 1075-1080, Dec. 1979.
- [9] G.F. Engen, "An improved circuit for implementing the six-port technique of microwave measurements," *IEEE Trans. Microwave Theory Tech.*, vol. MTT-25, no. 12, pp. 1080-1083, Dec. 1979.
- [10] W.L. Williams, "Computer-aided measurements of microwave circuits," Ph.D. dissertation, California Inst. of Technol., Pasadena, 1989.
- [11] G.F. Engen, "Calibrating the six-port reflectometer by means of sliding terminations," *IEEE Trans. Microwave Theory Tech.*, vol. MTT-26, pp. 951-957, Dec. 1978.
- [12] Virginia Diodes, Inc., 321 West Main Steet, Charlottesville, VA 22903, U.S.A. URL: <http://www.virginiadiodes.com>