

**FINAL REPORT  
MARCH 2002**

**REPORT NO. 01-08**

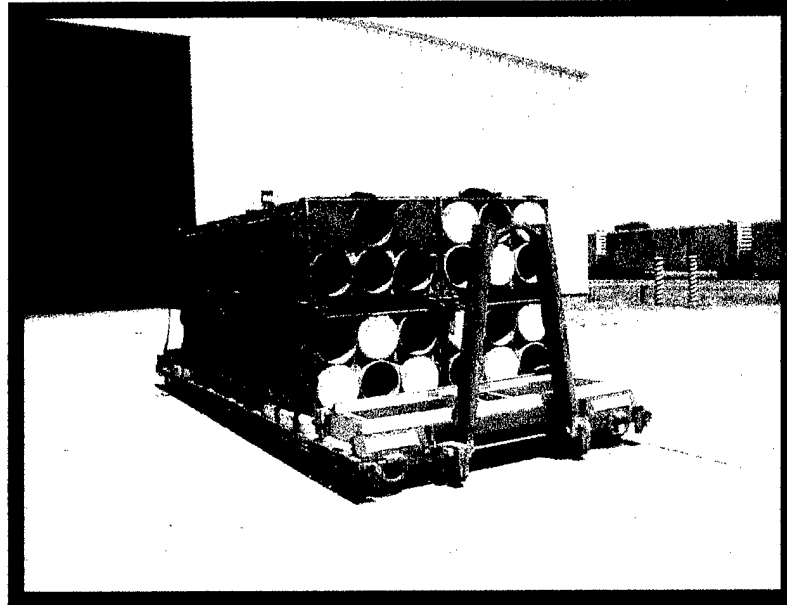

**STRATEGIC CONFIGURED LOAD (SCL) 24  
- ARMY TACTICAL MISSILE  
SYSTEM (ATACMS) EVALUATION  
TP-94-01, "TRANSPORTABILITY TESTING PROCEDURES"**

Prepared for:

**U.S. Army Defense Ammunition Center  
ATTN: SOSAC-DET  
1 C Tree Road  
McAlester, OK 74501-9053**



**VALIDATION ENGINEERING DIVISION  
MCALESTER, OKLAHOMA 74501-9053**

**DISTRIBUTION STATEMENT A  
Approved for Public Release  
Distribution Unlimited**

**20020604 078**

## **AVAILABILITY NOTICE**

A copy of this report will be furnished each attendee on automatic distribution. Additional copies or authority for reprinting may be obtained by written request from:

Director  
U.S. Army Defense Ammunition Center  
ATTN: SOSAC-DEV  
1 C Tree Road, Bldg. 35  
McAlester, OK 74501-9053

Reports may also be downloaded or viewed in PDF format from our web site at:

<http://www.dac.army.mil/DEV/TestReports>

## **DISTRIBUTION INSTRUCTIONS**

Destroy this report when no longer needed. Do not return.

\*\*\*

Citation of trade names in this report does not constitute an official endorsement.

\*\*\*

The information contained herein will not be used for advertising purposes

**REPORT NO. 01-08  
SCL 24 - ATACMS EVALUATION  
TP-94-01, "TRANSPORTABILITY TESTING PROCEDURES"**

**MARCH 2002**

**ABSTRACT**

The U.S. Army Defense Ammunition Center (DAC), Validation Engineering Division (SOSAC-DEV) was tasked by the Transportation Engineering Division (SOSAC-DET) to conduct transportability testing on the Strategic Configured Load (SCL) 24 - ATACMS. The SCL 24 - ATACMS was tested in accordance with TP-94-01, "Transportability Testing Procedures." Based on our review and evaluation of the tests, the SCL 24 - ATACMS, as currently designed, is considered to be adequate and safe for the transport of ammunition.

Prepared by:

Reviewed by:

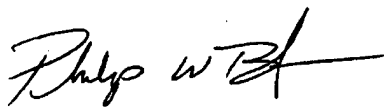

**PHILIP BARICKMAN**  
Lead Validation Engineer

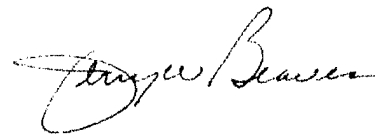

**JERRY W. BEAVER**  
Chief, Validation Engineering Division

**U.S. ARMY DEFENSE AMMUNITION CENTER  
VALIDATION ENGINEERING DIVISION  
MCALESTER, OK 74501-9053**

**REPORT NO. 01-08**

**SCL 24 - ATACMS EVALUATION  
TP-94-01, "Transportability Testing Procedures"**

**TABLE OF CONTENTS**

<b>PART</b>	<b>PAGE NO.</b>
1. INTRODUCTION .....	1-1
A. BACKGROUND.....	1-1
B. AUTHORITY.....	1-1
C. OBJECTIVE .....	1-1
D. CONCLUSION .....	1-1
2. ATTENDEES.....	2-1
3. TEST EQUIPMENT.....	3-1
4. TEST PROCEDURES .....	4-1
A. RAIL TEST .....	4-1
B. ON/OFF ROAD TESTS.....	4-2
1. HAZARD COURSE.....	4-2
2. ROAD TRIP .....	4-3
3. PANIC STOPS.....	4-4
4. WASHBOARD COURSE .....	4-4
C. OCEAN-GOING VESSEL TEST (STS).....	4-4
5. TEST RESULTS .....	5-1
A. RAIL TEST .....	5-2
B. ON/OFF ROAD TESTS.....	5-4
1. HAZARD COURSE.....	5-4
2. ROAD TRIP.....	5-5
3. PANIC STOPS.....	5-5
4. WASHBOARD COURSE.....	5-5
C. OCEAN-GOING VESSEL TEST (STS).....	5-6
6. DRAWINGS .....	6-1

## **PART 1 – INTRODUCTION**

**A. BACKGROUND.** The U.S. Army Defense Ammunition Center (DAC), Validation Engineering Division was tasked by the Transportation Engineering Division to conduct transportability testing on the Strategic Configured Load (SCL) 24 - ATACMS on a Container Roll-In/Out Platform (CROP).

**B. AUTHORITY.** This test was conducted IAW mission responsibilities delegated by the U.S. Army Operations Support Command (OSC), Rock Island, IL. Reference is made to the following:

1. AR 740-1, 15 June 2001, Storage and Supply Activity Operation.
2. IOC-R, 10-23, Mission and Major Functions of USADAC, 7 January 1998.

**C. OBJECTIVE.** The objective of the testing was to determine if SCL 24 as designed by SOSAC-DET, DAC (Transportation Engineering Division) satisfied the transportability requirements of TP-94-01.

**D. CONCLUSION.** Based on our review and testing, the SCL 24, as currently designed, successfully meets the requirements for the safe transportation of ammunition.

**PART 2 - ATTENDEES**

DATE PERFORMED: 16-17 August 2000

**ATTENDEES**

Philip Barickman  
General Engineer  
DSN 956-8992  
(918) 420-8992

Gregory Willis  
Industrial Engineer  
DSN 956-8075  
(918) 420-8075

**MAILING ADDRESS**

Director  
U.S. Army Defense Ammunition Center  
ATTN: SOSAC-DEV  
1 C Tree Road, Bldg. 35  
McAlester, OK 74501-9053

Director  
U.S. Army Defense Ammunition Center  
ATTN: SOSAC-DET  
1 C Tree Road, Bldg. 35  
McAlester, OK 74501-9053

### **PART 3 - TEST EQUIPMENT**

**A. Container Roll-In/Out Platform (CROP)**

Manufacturer: Summa Technologies, Inc.

Model: M1

NSN: 3990-01-442-2751

Tare Weight: 3,620 pounds

Max. Gross Weight: 36,250 pounds

**B. Tractor, Truck, 5-Ton**

Model No: XM818 w/o winch

ID NO: 05E-37770-0124-12331

Weight: 19,260 pounds

**C. Semi-trailer, Flatbed, 34 -Ton**

Model No: M872A1 Trailer

Manufacturer: Heller Truck Body Corp, Hillsdale, NJ

NSN: 2330-01-109-8006

ID No: 11-1505 NX05NZ

Weight: 19,240 pounds

**D. ISO Container w/155mm Separate Loading Projectiles (SLPs)**

Model: MILVAN PLS NA

Serial No: PLSM 861 ID No: SM10001

Date Manufactured: 7/92

Manufacturer: Steel Tech Manufacturing, Milwaukee, WI

Tare Weight: 7,200 lbs.

Max. Gross Weight: 44,800 lbs.

## **PART 4 - TEST PROCEDURES**

The test procedures outlined in this section were extracted from TP-94-01, "Transportability Testing Procedures," July 1994, for validating tactical vehicles and outloading procedures used for shipping munitions by tactical or commercial truck, railcar, and ocean-going vessel.

The rail impact test was conducted with the loaded CROP secured inside an intermodal container and secured directly to the railcar. Inert (non-explosive) items were used to build the load. The test loads were prepared using the blocking and bracing procedures proposed for use with munitions (see Part 6 for procedures). The weight and physical characteristics (weights, physical dimensions, center of gravity, etc.) of the test loads were identical to live (explosive) ammunition.

**A. RAIL TEST. RAIL IMPACT TEST.** The test load or vehicle will be secured to a flatcar. The equipment needed to perform the test will include the specimen (hammer) car, four empty railroad cars connected together to serve as the anvil, and a railroad locomotive. The anvil cars will be positioned on a level section of track with air and hand brakes set and with draft gears compressed. The locomotive unit will push the specimen car toward the anvil at a predetermined speed, then disconnect from the specimen car approximately 50 yards away from the anvil cars allowing the specimen car to roll freely along the track until it strikes the anvil. This will constitute an impact. Impacting will be accomplished at speeds of 4, 6, and 8.1 mph in one direction and at a speed of 8.1 mph in the reverse direction. The speeds will have a tolerance of plus .5 mph and minus zero mph. The impact speeds will be determined by using an electronic counter to measure the time for the specimen car to traverse an 11-foot distance immediately prior to contact with the anvil cars (see Figure 1).

ASSOCIATION OF AMERICAN RAILROADS (AAR)  
STANDARD TEST PLAN

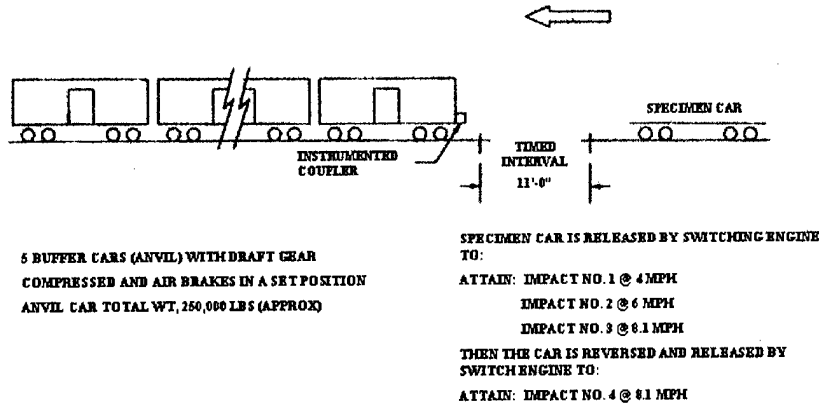
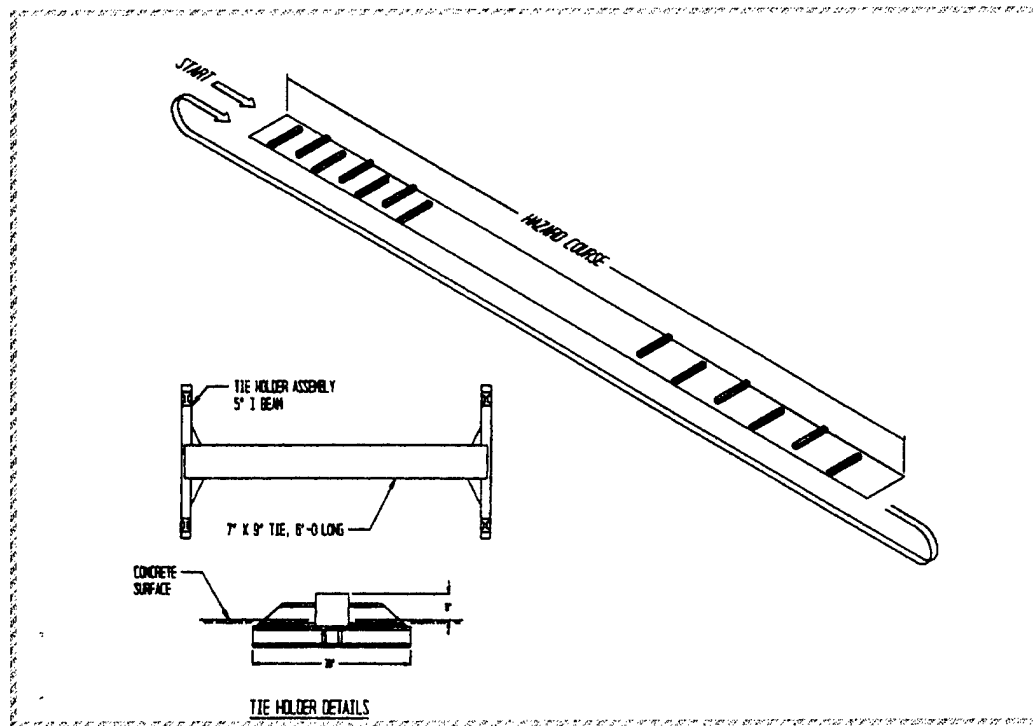

Figure 1. Rail Impact Sketch

B. ON/OFF ROAD TEST.

1. HAZARD COURSE. The test load or vehicle will be transported over the 200-foot-long segment of concrete-paved road consisting of two series of railroad ties projecting 6 inches above the level of the road surface. The hazard course will be traversed two times (see Figure 2).



**Figure 2. Hazard Course Sketch**

- a. The first series of ties are spaced on 10-foot centers and alternately positioned on opposite sides of the road centerline for a distance of 50 feet.
- b. Following the first series of ties, a paved roadway of 75 feet separates the first and second series of railroad ties.
- c. The second series of ties are spaced on 8-foot centers and alternately positioned on opposite sides of the road centerline for a distance of 50 feet.
- d. The test load is driven across the hazard course at speeds that will produce the most violent vertical and side-to-side rolling reaction obtainable in traversing the hazard course (approximately 5 mph).

**2. ROAD TRIP.** The test load or vehicle will be transported for a distance of 30 miles over a combination of roads surfaced with gravel, concrete, and asphalt. The test route will include curves, corners, railroad crossings and stops and starts. The test load or vehicle will travel at the maximum speed for the particular road being traversed, except as limited by legal restrictions.

3. **PANIC STOPS**. During the road trip, the test load or vehicle will be subjected to three (3) full airbrake stops while traveling in the forward direction and one in the reverse direction while traveling down a 7-degree grade. The first three stops are at 5, 10, and 15 mph while the stop in the reverse direction is approximately 5 mph. This testing will not be required if the Rail Impact Test is performed.

4. **WASHBOARD COURSE**. The test load or vehicle will be driven over the washboard course at a speed that produces the most violent response in the vertical load direction.

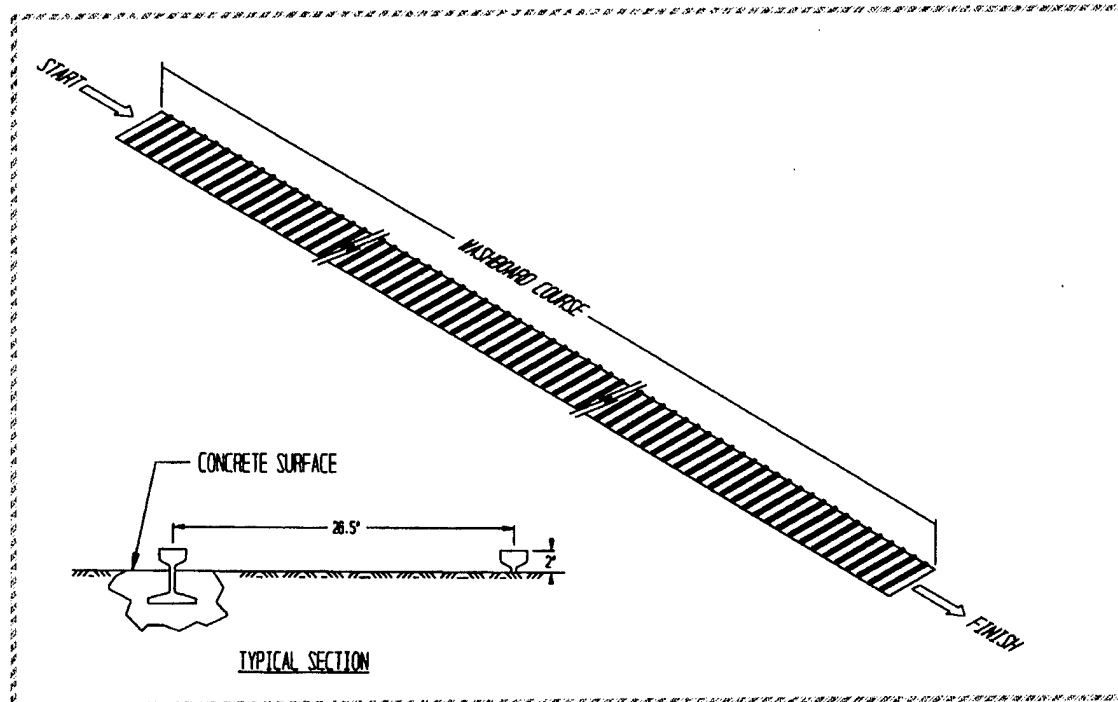

Figure 3. Washboard Course Sketch

C. **OCEAN-GOING VESSEL TEST. SHIPBOARD TRANSPORTATION SIMULATOR (STS) TEST METHOD**. The test load will be secured inside an ISO container and will be positioned onto the STS and securely locked in place using the cam locks at each corner. Oscillation of the STS will be started and rotate to an angle of 30 degrees plus or minus 2 degrees, either side of center

and at a frequency of 2 cycles-per-minute (30 seconds plus or minus 2 seconds total roll period). This frequency will be observed for apparent defects that could cause a safety hazard. The frequency of oscillation will then be increased to 4 cycles-per-minute (15 seconds plus or minus 1 second per roll period) and the apparatus operated a period of two (2) hours. An inspection of the load will then be conducted. If the inspection does not indicate an impending failure, the frequency of oscillation will be further increased to 5 cycles-per-minute (12 seconds plus or minus 1 second-cycle time), and the apparatus operated for four (4) hours. The operation does not necessarily have to be continuous, however, no change or adjustments to the load or load restraints will be permitted at any time during the test. After once being set in place, the test load (specimen) will not be removed from the apparatus until the test has been completed or is terminated.

## **PART 5 - TEST RESULTS**

Payload: Strategic Configured Load (SCL) 24

Gross Weight: 24,517 pounds

Testing Date: 16 August 2000

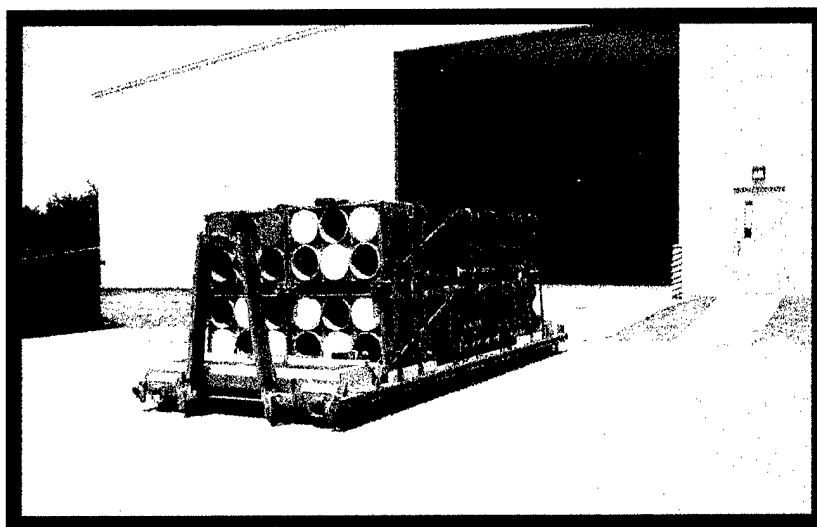

**Photo 2: SCL 24 Prior to Loading into Container**

**A. RAIL TEST. RAIL IMPACT TEST METHOD.**

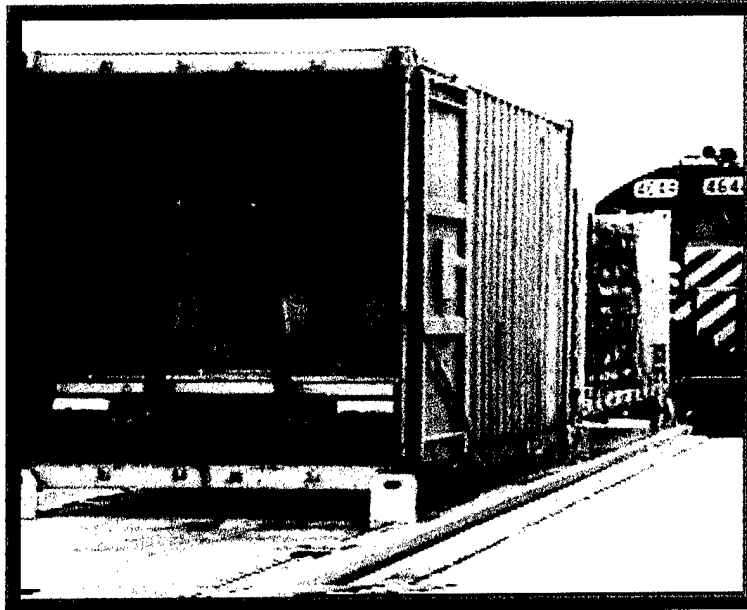

**Photo 3: Rail Impact Testing of SCL24**

Description	Weight
Flatcar Number: DODX 48797	62,700 lbs.
CROP and SCL #24	24,517 lbs.
ISO Container	4,800 lbs.
ISO Container (ID No. SM10001) w/155mm Projectiles	41,220 lbs.
M1 Flatrack w/MLRS Pods	28,265 lbs.
Total Specimen Wt.	161,502 lbs.
Buffer Car (four cars)	250,000 lbs.

**Figure 4**

**Remarks:** Figure 4 lists the test components and weights of the items used during the Rail Impact Tests. The SCL 24 w/CROP was loaded into the ISO container and the container was secured to the rail flatcar. The M1 flatrack with MLRS pods and the containerized 155mm SLPs were utilized as ballast for the test.

<b>Impact Number</b>	<b>Avg. Velocity (mph)</b>	<b>Remarks</b>
<b>1</b>	<b>4.2</b>	
<b>2</b>	<b>6.3</b>	<b>1/8" movement of the payload</b>
<b>3</b>	<b>8.3</b>	
<b>4</b>	<b>8.3</b>	

**Figure 5**

**Remarks:** Figure 5 lists the average speeds of the flat railcar immediately prior to impact with the anvil. The reverse Impact is #4. No damage or failures occurred with the straps or tie-down rings.

**B. ON/OFF ROAD TESTS.**

**1. HAZARD COURSE.**



**Photo 4: Hazard Course Testing of SCL 24**

**Remarks:** The SCL 24 w/CROP was loaded into an ISO container and secured to a 40-foot flatbed trailer prior to transport through the Hazard Course. On the third pass the transport vehicle came out of gear. The vehicle was put back into gear and the test pass completed. No official time was recorded.

<b>Pass No.</b>	<b>Elapsed Time</b>	<b>Avg. Velocity (mph)</b>
<b>1</b>	<b>25 Seconds</b>	<b>5.9</b>
<b>2</b>	<b>22 Seconds</b>	<b>6.7</b>
<b>3</b>	<b>no time</b>	
<b>4</b>	<b>24 Seconds</b>	<b>6.1</b>

**Figure 6**

**Remarks:** Figure 6 lists the average speeds of the test load through the Hazard Course. No damage or failures occurred with the straps or tie-down rings. Pass Nos. 3 and 4 were performed after the completion of the Road Trip.

2. **ROAD TRIP.** No damage or failures occurred with the SCL 24.

3. **PANIC STOPS.** Testing was not required since the load had been rail impact tested.

3. **WASHBOARD.**

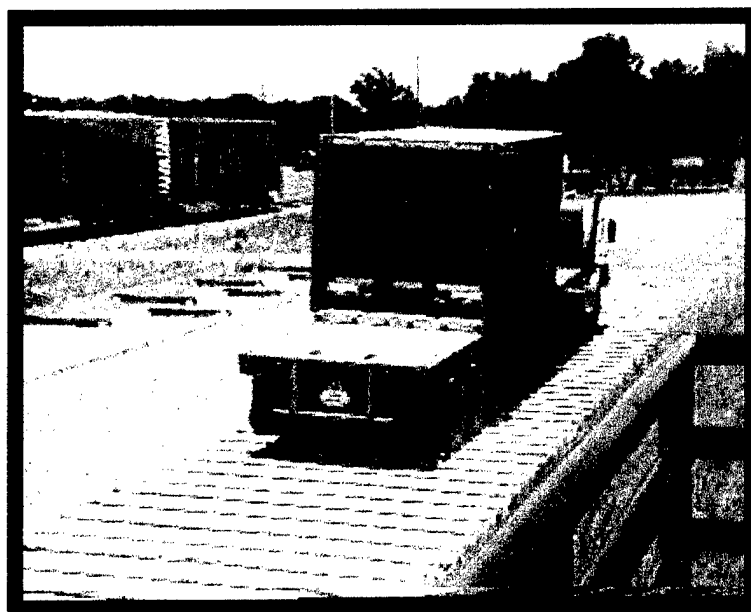

**Photo 5: Washboard Course Testing of SCL 24**

**Remarks:** No damage or failures occurred with the SCL 24 and excessive load movement did not occur.

**C. OCEAN-GOING VESSEL. SHIPBOARD TRANSPORTATION SIMULATOR  
(STS) TEST METHOD.**

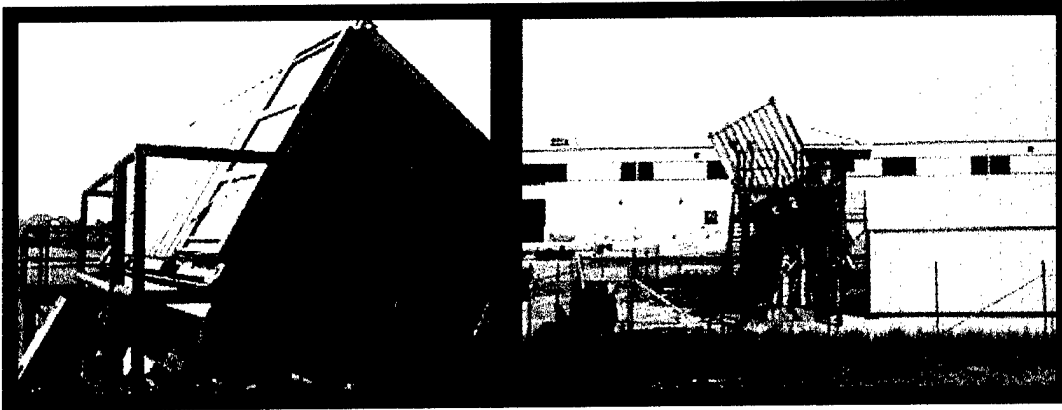

**Photo 6 & 7: STS Testing of SCL 24**

**Remarks:** The ISO container and the SCL 24 w/CROP were removed from the trailer and positioned onto the STS Tester. No damage or failure occurred to the SCL 24.

## **PART 6 – DRAWINGS**

The following drawing, AMC 1948-4905/24, represents the load configuration that was subjected to the test criteria. The drawing can be accessed at <http://www.dac.army.mil/DET/dapam/toc.html> upon final signatory approval.

*D. L.*  
DATE 10/11/2000

# APPENDIX 24

## LOADING AND BRACING PROCEDURES FOR STRATEGIC CONFIGURED LOAD (SCL) ON CONTAINER ROLL IN/OUT PLATFORM (CROP)

### SCL #24 - ATACMS

#### INDEX

<u>ITEM</u>	<u>PAGE(S)</u>
TYPICAL LOADING PROCEDURES - - - - -	2
GENERAL NOTES AND SEQUENTIAL LOADING PROCEDURES - - - - -	3
MISSILE/LAUNCH POD ASSEMBLY DETAILS - - - - -	4
DETAILS - - - - -	5-7

**NOTICE: THIS APPENDIX CANNOT STAND ALONE BUT MUST BE USED IN CONJUNCTION WITH THE BASIC CROP OUTLOADING PROCEDURES DRAWING 19-48-4905-CA17Q6.**

- LOADING AND BRACING SPECIFICATIONS SET FORTH WITHIN THIS DRAWING ARE APPLICABLE TO LOADS THAT ARE TO BE SHIPPED BY TRAILER/CONTAINER-ON-FLATCAR (T/COFC) RAIL CARRIER SERVICE. THESE SPECIFICATIONS MAY ALSO BE USED FOR LOADS THAT ARE TO BE MOVED BY MOTOR OR WATER CARRIERS.

### U.S. ARMY MATERIEL COMMAND DRAWING

APPROVED, U.S. ARMY AVIATION AND MISSILE COMMAND  <i>Mark T. Vanich</i>	ENGINEER	BASIC	WALTER GORDON		DO NOT SCALE			
		REV.			WEBSITE: <a href="http://www.dac.army.mil">HTTP://WWW.DAC.ARMY.MIL</a>			
	TECHNICIAN	BASIC			SEPTEMBER 2000			
		REV.						
	DRAFTSMAN	BASIC						
		REV.						
APPROVED BY ORDER OF COMMANDING GENERAL, U.S. ARMY MATERIEL COMMAND  <i>[Signature]</i> U.S. ARMY DEFENSE AMMUNITION CENTER	TRANSPORTATION ENGINEERING DIVISION		<i>William P. Inrich</i>					
	VALIDATION ENGINEERING DIVISION		TESTED		CLASS	DIVISION	DRAWING	FILE
	ENGINEERING DIRECTORATE				19	48	4905/ 24	CA17Q6

PROJECT CAP-TV 6/24-00

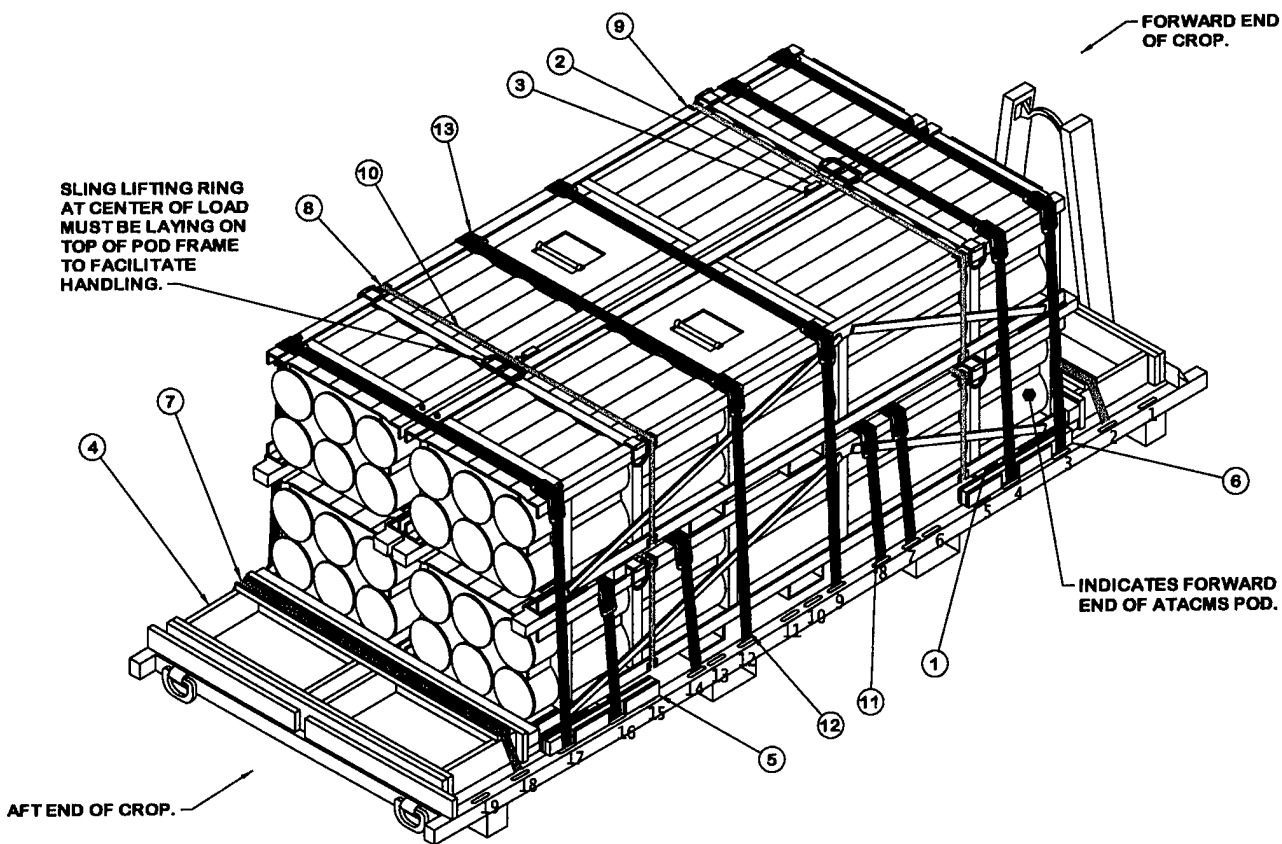

### ISOMETRIC VIEW

(KEY NUMBERS CONTINUED)

- ⑧ BUNDLING STRAP, 1-1/4" X .035" OR .031" X 19'-6" LONG STEEL STRAPPING (4 REQD). INSTALL TO ENIRCLE LATERALLY ADJACENT PODS IN EACH LAYER AS SHOWN.
- ⑨ EDGE PROTECTOR, 2-3/4" X .030" X 2" STEEL EDGE PROTECTOR (16 REQD). POSITION BETWEEN BUNDLING STRAP AND POD FRAME AT EACH CORNER.
- ⑩ SEAL, FOR 1-1/4" STEEL STRAPPING (4 REQD). NOTCH EACH SEAL WITH TWO PAIR OF NOTCHES.
- ⑪ LOWER HOLD-DOWN STRAP, 3-INCH WIDE WEB STRAP TIE-DOWN ASSEMBLY FOR CROP (4 REQD). INSTALL EACH LOWER HOLD-DOWN STRAP TO EXTEND FROM THE DESIGNATED TIE-DOWN ANCHOR ON SIDE OF CROP, OVER TOP OF LOWER LAYER OF PODS, TO CORRESPONDING TIEDOWN ANCHOR ON OPPOSITE SIDE OF CROP. FIRMLY TENSION STRAP. SEE GENERAL NOTE "F" ON PAGE 3.
- ⑫ UPPER HOLD-DOWN STRAP, 3-INCH WIDE WEB STRAP TIEDOWN ASSEMBLY FOR CROP (6 REQD). INSTALL EACH UPPER LAYER HOLD-DOWN STRAP TO EXTEND FROM THE DESIGNATED TIE-DOWN ANCHOR ON SIDE OF CROP, OVER TOP OF TOP LAYER OF PODS, TO CORRESPONDING TIEDOWN ANCHOR ON OPPOSITE SIDE OF CROP. FIRMLY TENSION STRAP. SEE GENERAL NOTE "F" ON PAGE 3.
- ⑬ EDGE PROTECTOR, 11-3/4" X 3/8" X 4-1/4" REINFORCED RUBBER EDGE PROTECTOR (18 REQD). SLIDE OVER 3-INCH WEB STRAP AND POSITION BETWEEN SCUFF SLEEVE OF WEB STRAP AND POD FRAME AT EACH CORNER.

### KEY NUMBERS

- ① SUPPORT ASSEMBLY (4 REQD). SEE THE DETAIL ON PAGE 7. CENTER A SUPPORT ASSEMBLY CROSSWISE ON THE DECK OF CROP APPROXIMATELY 50" FROM EACH ENDGATE OF CROP. POSITION TWO MORE SUPPORT ASSEMBLIES BETWEEN LAYERS OF PODS AS SHOWN.
- ② CENTER FILL PIECE, 2" X 4" X 64" (2 REQD). POSITION EACH CENTER FILL PIECE APPROXIMATELY 34" FROM EACH END OF THE POD FRAME AS SHOWN.
- ③ TIE WIRE, 0.0800" DIA, 24" LONG (4 REQD). FASTEN EACH CENTER FILL PIECE, PIECE MARKED ②, TO ONE STACK OF PODS AT TWO LOCATIONS, LOOPING WIRE AROUND FRAME OF POD, BRINGING ENDS TOGETHER, AND TWISTING TAUT.
- ④ END BLOCKING ASSEMBLY (2 REQD). SEE THE DETAILS ON PAGE 5. CENTER EACH END BLOCKING ASSEMBLY AGAINST EACH ENDGATE OF CROP. ENSURE TIGHT END-TO-END FIT BETWEEN ENDGATES AND PODS. SEE GENERAL NOTE "J" ON PAGE 3.
- ⑤ SIDE BLOCKING ASSEMBLY A (2 REQD). SEE THE DETAIL ON PAGE 6. POSITION ONE AGAINST SKID ON FRONT DRIVERSIDE OF LOAD AND ONE AGAINST SKID ON AFT CURBSIDE OF LOAD AS SHOWN. AFTER THE HOLD-DOWN STRAPS ARE INSTALLED, NAIL THROUGH THE HOOK ATTACHMENT SLOT OF EACH ADJACENT HOLD-DOWN STRAP INTO SIDE BLOCKING W/1-10d PARTIALLY DRIVEN NAIL AND BEND OVER SIDE OF HOOK.
- ⑥ SIDE BLOCKING ASSEMBLY B (2 REQD). SEE THE DETAIL ON PAGE 6. POSITION ONE AGAINST SKID ON AFT DRIVERSIDE OF LOAD AND ONE AGAINST SKID ON FRONT CURBSIDE AS SHOWN. AFTER THE HOLD-DOWN STRAPS ARE INSTALLED, NAIL THROUGH THE HOOK ATTACHMENT SLOT OF EACH ADJACENT HOLD-DOWN STRAP INTO SIDE BLOCKING W/1-10d PARTIALLY DRIVEN NAIL AND BEND OVER SIDE OF HOOK.
- ⑦ RETAINER STRAP, 2-INCH WIDE WEB STRAP TIEDOWN ASSEMBLY (2 REQD). INSTALL EACH RETAINER STRAP TO EXTEND FROM A TIEDOWN RING ON SIDE OF CROP, OVER TOP OF STRAPPING BOARD OF END BLOCKING ASSEMBLY, TO CORRESPONDING TIE-DOWN RING ON OPPOSITE SIDE OF CROP. POSITION STRAP SCUFF SLEEVES AT SHARP EDGES. TAKE UP EXCESS SLACK IN STRAP AND THEN RATCHET TIGHT. SEE GENERAL NOTE "F" ON PAGE 3.

(CONTINUED AT LEFT)

**RECOMMENDED SEQUENTIAL PROCEDURES**

1. PREFABRICATE THE FORWARD END BLOCKING ASSEMBLY WITH FILL PIECE, BUT WITHOUT BEARING PIECE AND STRAPPING BOARD. PREFABRICATE FOUR SUPPORT ASSEMBLIES, TWO CENTER FILL PIECES, FOUR SIDE BLOCKING ASSEMBLIES, AND THE AFT END BLOCKING ASSEMBLY WITHOUT FILL PIECE.
2. INSTALL THE PARTIAL FORWARD END BLOCKING ASSEMBLY AND PLACE TWO SUPPORT ASSEMBLIES CROSSWISE ON THE DECK OF CROP.
3. ORIENT POD LIFTING RINGS AND LOAD THE FIRST LAYER OF PODS WITH CENTER FILL PIECES BETWEEN THE TWO PODS. CENTER PODS CROSSWISE ON CROP AND PLACE THEM TIGHTLY AGAINST FORWARD END BLOCKING ASSEMBLY.
4. BUNDLE THE TWO PODS TOGETHER WITH 1-1/4" STEEL STRAPPING.
5. WIRE TIE THE CENTER FILL PIECES TO THE FRAME OF ONE POD.
6. INSTALL BEARING PIECE AND STRAPPING BOARD ON FORWARD END BLOCKING ASSEMBLY.
7. INSTALL THE AFT END BLOCKING ASSEMBLY AND FILL PIECE.
8. INSTALL THE TWO AFT SIDE BLOCKING ASSEMBLIES: SIDE BLOCKING ASSEMBLY "A" ON THE CURBSIDE OF THE LOAD AND SIDE BLOCKING ASSEMBLY "B" ON THE DRIVERSIDE OF THE LOAD.
9. INSTALL FOUR 3" WEB STRAP TIEDOWN ASSEMBLIES TO EXTEND FROM A TIEDOWN ANCHOR ON ONE SIDE OF THE CROP, OVER TOP OF LOWER LAYER OF PODS, TO THE CORRESPONDING TIEDOWN ANCHOR ON THE OPPOSITE SIDE OF THE CROP.
10. INSTALL THE REMAINING TWO SUPPORT ASSEMBLIES. ORIENT POD LIFTING RINGS AND LOAD SECOND LAYER OF PODS.
11. BUNDLE THE TWO PODS IN THE TOP LAYER TOGETHER WITH 1-1/4" STEEL STRAPPING.
12. WIRE TIE CENTER FILL PIECES TO POD IN TOP LAYER ABOVE PREVIOUSLY TIED POD.
13. INSTALL THE TWO FORWARD SIDE BLOCKING ASSEMBLIES: SIDE BLOCKING ASSEMBLY "B" ON THE CURBSIDE OF THE LOAD AND SIDE BLOCKING ASSEMBLY "A" ON THE DRIVERSIDE OF THE LOAD.
14. INSTALL FIVE 3" WEB STRAP TIEDOWN ASSEMBLIES TO EXTEND FROM A TIEDOWN ANCHOR ON ONE SIDE OF THE CROP, OVER THE TOP OF THE TOP LAYER OF PODS, TO THE CORRESPONDING TIEDOWN ANCHOR ON THE OPPOSITE SIDE OF THE CROP.
15. INSTALL TWO 2" RETAINER STRAPS, ONE OVER EACH END BLOCKING ASSEMBLY.
16. NAIL THROUGH THE HOOK ATTACHMENT SLOT OF A HOLD-DOWN STRAP INTO EACH END OF THE SIDE BLOCKING ASSEMBLIES WITH 10d PARTIALLY DRIVEN NAIL AND BEND OVER SIDE OF HOOK.

**GENERAL NOTES**

- A. THIS APPENDIX CANNOT STAND ALONE BUT MUST BE USED IN CONJUNCTION WITH THE BASIC LOADING PROCEDURES DRAWING 19-48-4905-CA17Q6. TO PRODUCE AN APPROVED LOAD, ALL PERTINENT PROCEDURES, SPECIFICATIONS AND CRITERIA SET FORTH WITHIN THE BASIC DRAWING WILL APPLY TO THE PROCEDURES DELINEATED IN THIS APPENDIX. ANY EXCEPTIONS TO THE BASIC PROCEDURES ARE SPECIFIED IN THIS APPENDIX.
- B. THE OUTLOADING PROCEDURES DEPICTED IN THIS DRAWING ARE APPLICABLE TO LOADS OF SCL #24. SEE PAGE 4 FOR DETAILS OF THE ATACMS POD. AN M3 (SUMMA) CROP IS SHOWN AS TYPICAL. OTHER MANUFACTURER'S CROPS CAN BE USED FOR THE LOAD SHOWN ON PAGE 2. THE SEQUENTIAL LOADING PROCEDURES DEPICTED AT LEFT DESCRIBE THE SEQUENCE USED TO LOAD AN M3 CROP. ACTUAL CROP CONFIGURATION WILL DETERMINE WHETHER THE SEQUENTIAL LOADING STARTS AT THE AFT OR THE FORWARD END OF THE CROP.
- C. THE LOADING PROCEDURES DEPICTED HEREIN MAY ALSO BE USED FOR OUTLOADING SIMILAR SCL LOADS WHEN IDENTIFIED BY DIFFERENT NATIONAL STOCK NUMBERS (NSN) THAN WHAT IS SHOWN ON PAGE 4, PROVIDED THE OVERALL UNIT DIMENSIONS DO NOT VARY FROM WHAT IS DELINEATED HEREIN.
- D. ALTERNATE NSN/DODIC COMBINATIONS ARE SHOWN IN THE CHART ON PAGE 4. THESE ALTERNATES MAY BE SUBSTITUTED FOR SOME OR ALL THE DEPICTED NSN/DODICS IF NECESSARY DUE TO THE ITEMS OR QUANTITIES ON HAND.
- E. DIMENSIONS GIVEN FOR DUNNAGE ASSEMBLIES WILL BE FIELD CHECKED PRIOR TO THEIR ASSEMBLY. PODS MUST FIT SNUGLY AGAINST THE DUNNAGE ASSEMBLIES. THIS GUIDANCE MUST BE APPLIED PRIOR TO BEGINNING AN OUTLOADING OPERATION. ALSO, DUE TO VARIATIONS IN HEIGHT OF SKIDS, ADJUSTMENTS MAY BE REQUIRED AS TO THE LOCATION OF CERTAIN PIECES ON DUNNAGE ASSEMBLIES.
- F. ALL WEB STRAP TIEDOWN ASSEMBLIES MUST HAVE THE EXCESS LENGTH OF THE STRAP SECURED. ROLL UP AND BUNDLE THE EXCESS LENGTH OF WEB STRAP, SECURING WITH CABLE TIES. SEE THE "STRAP END SECUREMENT" DETAIL AND GENERAL NOTE "K.12" IN THE BASIC PROCEDURE DRAWING 19-48-4905-CA17Q6.
- G. THE SUPPORT ASSEMBLY AS SHOWN ON PAGE 7 MUST BE USED UNDER BOTH LAYERS OF CONTAINERS TO PREVENT DAMAGE TO THE SHOCK ISOLATORS.
- H. CAUTION: CARE MUST BE EXERCISED TO INSURE THAT PRESSURE IS NOT APPLIED AGAINST THE BODY (ENDS AND SIDES) OF THE CONTAINERS OR THE UPPER RAIL NEAR THE CROSSMEMBER MARKED "NO STEP" DURING HANDLING OPERATIONS OR WHEN BRACED. ALSO, PERSONNEL SHALL NOT STAND OR WALK ON THE CONTAINER BODY OR THE CROSSMEMBERS SO MARKED.
- J. NEW STYLE PODS HAVE AN END COVER ON THE AFT END OF THE CONTAINER, WHICH EXTENDS SLIGHTLY BEYOND THE TOP AND BOTTOM RAILS. THE ALTERNATE END BLOCKING ASSEMBLY ON PAGE 5 MUST BE USED WHEN BRACING THE AFT END OF THESE CONTAINERS.
- K. CONVERSION TO METRIC EQUIVALENTS: DIMENSIONS WITHIN THIS DOCUMENT ARE EXPRESSED IN INCHES, AND WEIGHTS ARE EXPRESSED IN POUNDS. WHEN NECESSARY, THE METRIC EQUIVALENTS MAY BE COMPUTED ON THE BASIS OF ONE INCH EQUALS 25.4MM AND ONE POUND EQUALS 0.454 KG.

BILL OF MATERIAL		
LUMBER	LINEAR FEET	BOARD FEET
1" X 2" (ACTUAL)	11	2
1" X 4"	67	22
2" X 4"	35	23
2" X 8"	56	74
4" X 4"	42	55
NAILS	NO. REQD	POUNDS
8d (2-1/2")	128	1/2
10d (3")	104	1-3/4
STEEL STRAPPING, 1-1/4" - - -	83' REQD - - -	11.86 LBS
SEAL FOR 1-1/4" STRAPPING - - -	4 REQD - - - - -	NIL
EDGE PROTECTORS FOR 1-1/4" STEEL STRAPPING - - - - -	16 REQD - - - - -	1.6 LBS
WIRE, 0.0800" DIA - - - - -	8' REQD - - - - -	NIL
2" WEB STRAP TIEDOWN ASSEMBLY - - - - -	2 REQD - - - - -	11 LBS
EDGE PROTECTORS FOR 3" WEB STRAPS - - - - -	18 REQD - - - - -	13.5 LBS

**LOAD AS SHOWN**

ITEM	QUANTITY	WEIGHT (APPROX)
M/LPA - - - - -	4 - - - - -	20,420 LBS
DUNNAGE - - - - -	- - - - -	397 LBS
CROP - - - - -	- - - - -	3,800 LBS
TOTAL WEIGHT - - - - -		24,617 LBS (APPROX)

## SCL #24 COMPOSITION CHART

DODIC	NSN	NOMENCLATURE	UNIT DWG	REQD	UNITS REQD	HC
PL81	1427-00-000-0195	GM AND LAUNCHING ASSEMBLY, SURFACE ATTACK, M39	13288685	4	N/A	1. 1E
<b>NOTE: THE DODICS LISTED BELOW MAY BE USED AS ALTERNATES FOR THE DODIC SHOWN ABOVE IF THE QUANTITY OF THE DODIC SHOWN ABOVE IS INSUFFICIENT.</b>						
PL81	1427-01-274-3904	GM AND LAUNCHING ASSEMBLY, SURFACE ATTACK, M39	13288001			1. 1E
PL81	1427-01-386-3113	GM AND LAUNCHING ASSEMBLY, SURFACE ATTACK, M39	13288692			1. 1E
PL38	1427-01-398-6538	GM AND LAUNCHING ASSEMBLY, SURFACE ATTACK, M39A1	13366000			1. 1E
PL38	1427-01-463-0001	GM AND LAUNCHING ASSEMBLY, SURFACE ATTACK, M39A1	13365998			1. 1E
PL47	1427-01-439-8639	GM AND LAUNCHING ASSEMBLY, SURFACE ATTACK, M39A3	13330600			1. 1E

PL81 MUST NOT BE MIXED WITH PL38 OR PL47 IN THE SAME LAYER.

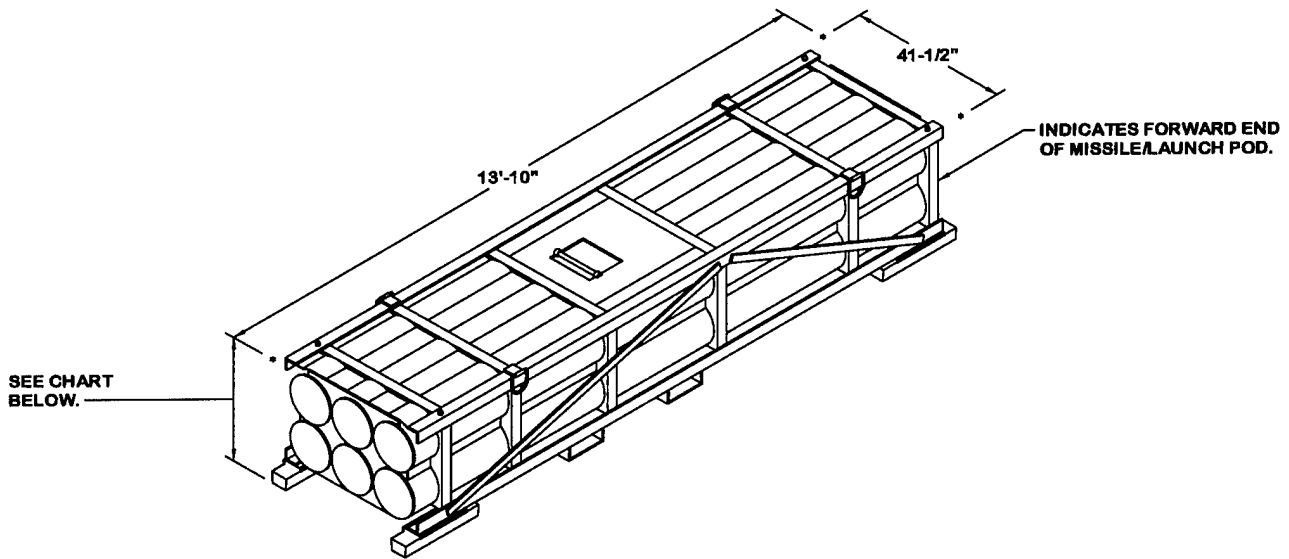

**MISSILE/LAUNCH POD ASSEMBLY**

GROSS WEIGHT, DIMENSIONS, AND CUBE OF MISSILE/LAUNCH POD ASSEMBLIES							
NSN	DODIC	TYPE	LENGTH	WIDTH	HEIGHT	WEIGHT (LBS)	CUBE (CU FT)
1427-00-000-0195	PL81	BLOCK I	13' - 10"	41-1/2"	32-5/8"	5, 105	129. 7
1427-01-274-3904	PL81	BLOCK I	13' - 10"	41-1/2"	32-5/8"	4, 814	129. 7
1427-01-386-3113	PL81	BLOCK I	13' - 10"	41-1/2"	32-5/8"	5, 111	129. 7
1427-01-398-6538	PL38	BLOCK IA	13' - 10"	41-1/2"	33-3/4"	4, 640	134. 6
1427-01-463-0001	PL38	BLOCK IA	13' - 10"	41-1/2"	33-3/4"	4, 640	134. 6
1427-01-439-8639	PL47	BLOCK II	13' - 10"	41-1/2"	33-3/4"	4, 985	134. 6

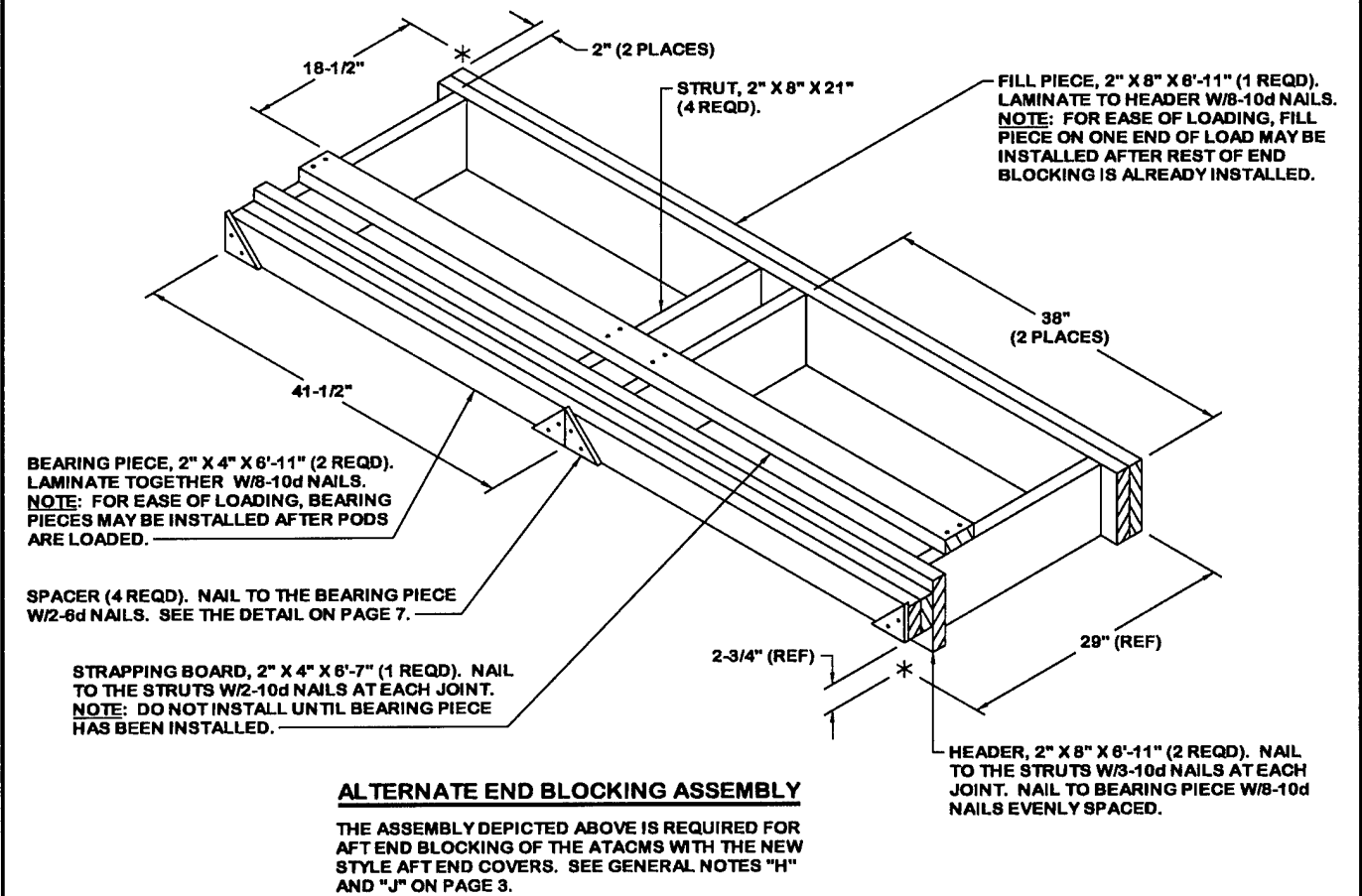
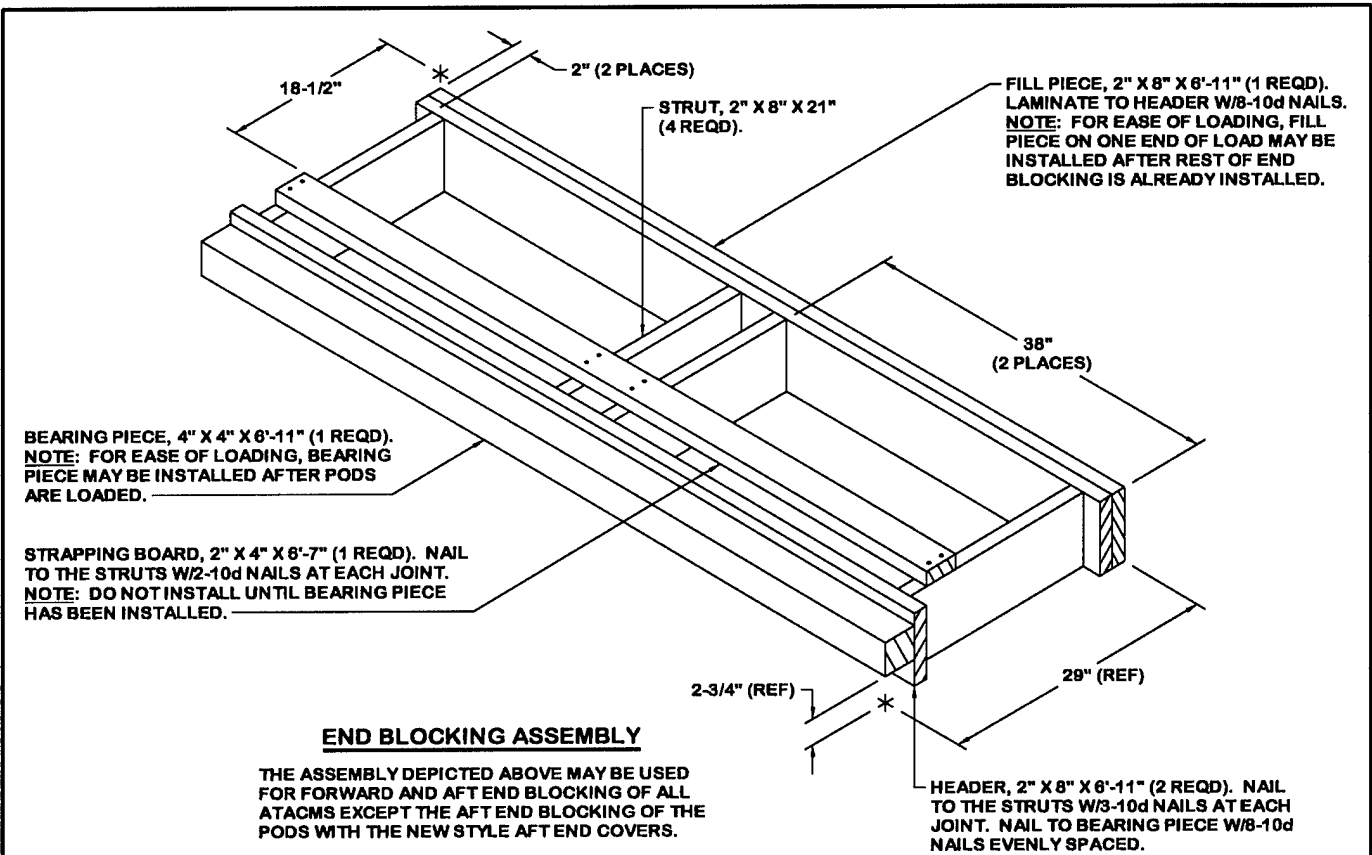

**DETAILS**

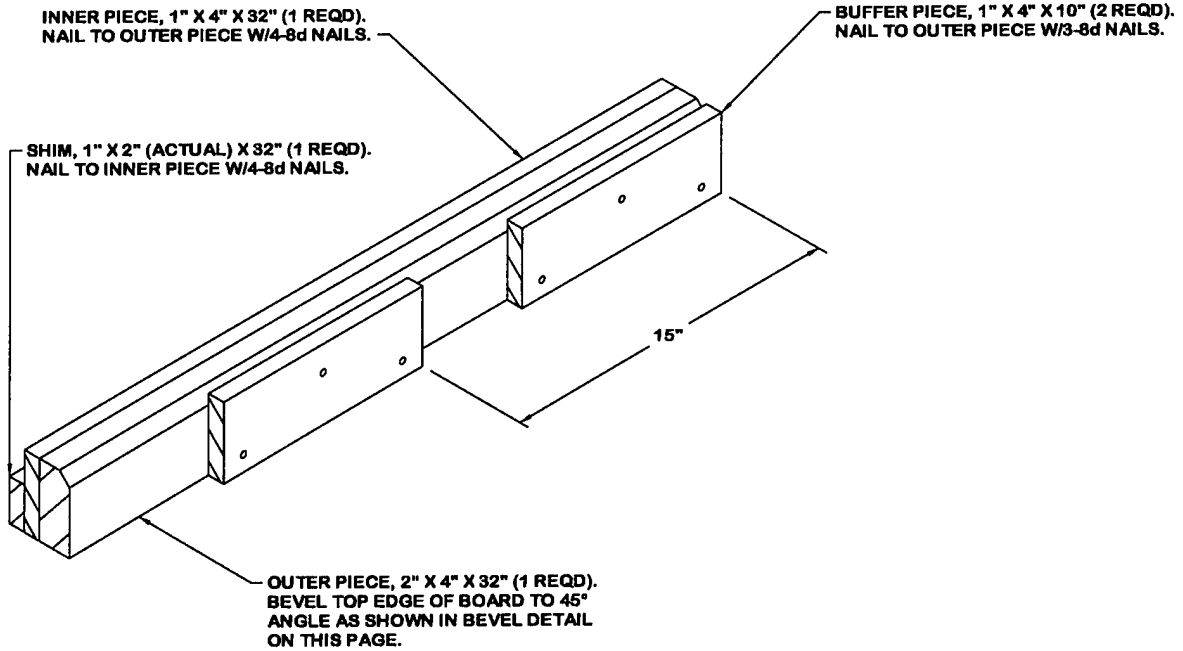

**SIDE BLOCKING ASSEMBLY A**

THIS ASSEMBLY IS USED ON THE FRONT DRIVER-SIDE AND THE AFT CURBSIDE OF THE LOAD.

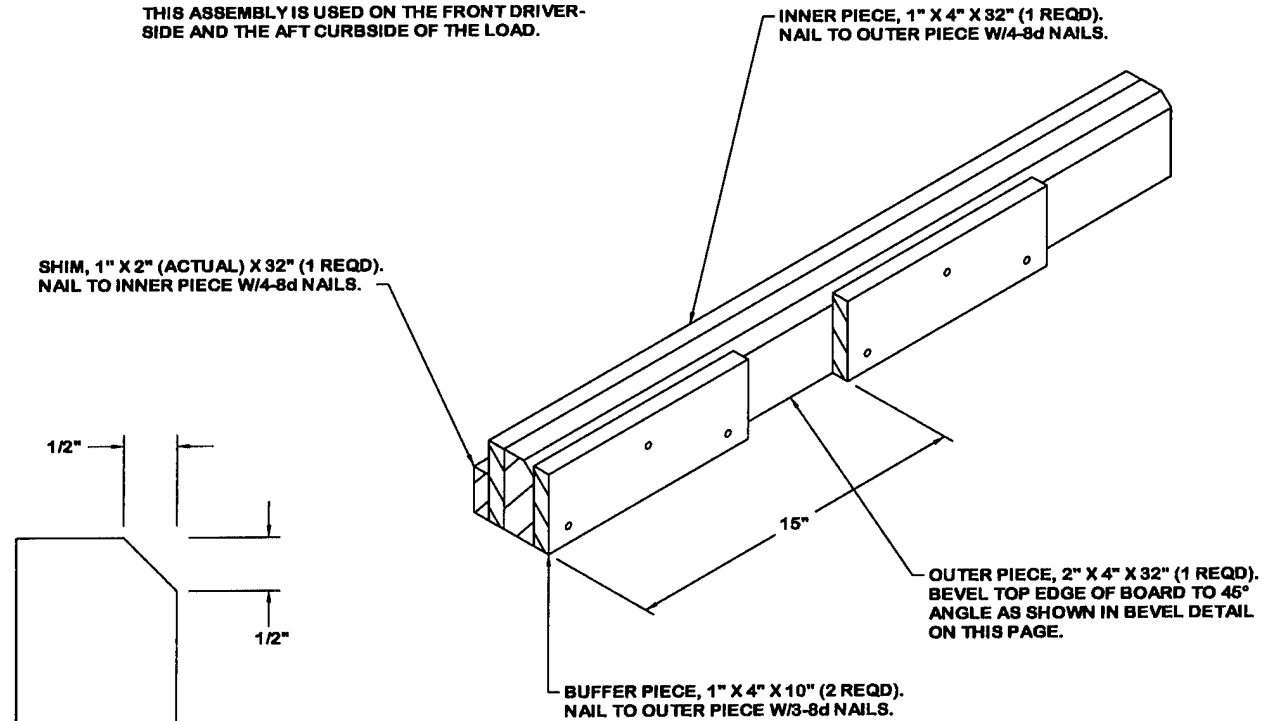

**SIDE BLOCKING ASSEMBLY B**

THIS ASSEMBLY IS USED ON THE AFT DRIVER-SIDE AND THE FRONT CURBSIDE OF THE LOAD.

**BEVEL DETAIL**

**DETAILS**

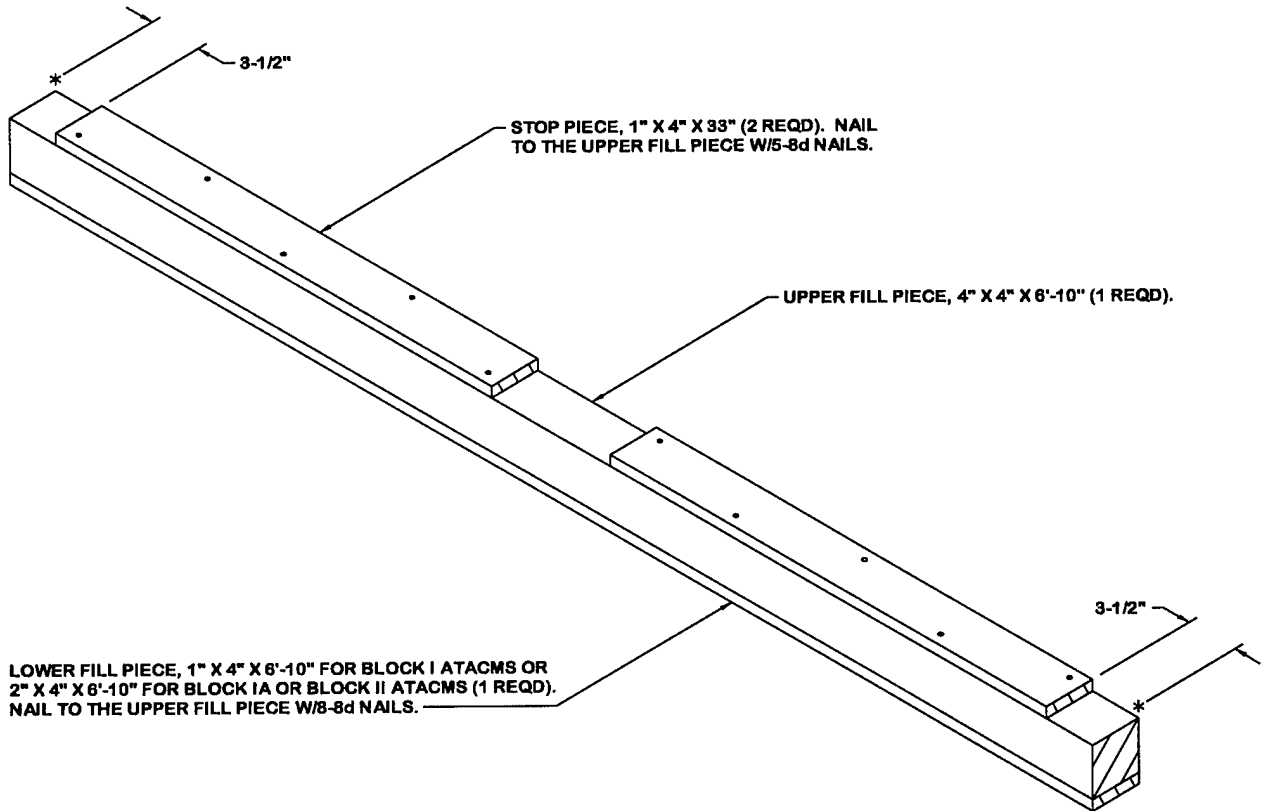

**SUPPORT ASSEMBLY**

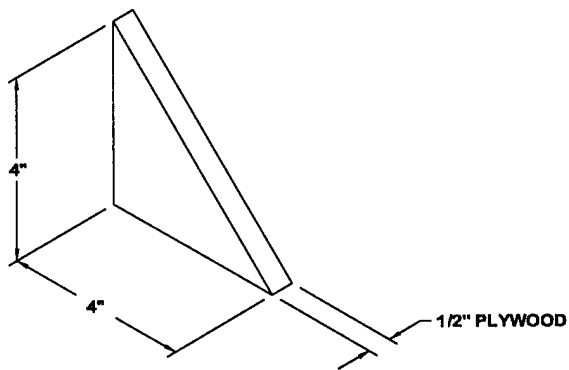

**SPACER**

THE SPACER IS USED IN THE ALTERNATE  
END BLOCKING ASSEMBLY ON PAGE 5.

**DETAILS**

