

**An Auxiliary Interface  
Instrumentation Module for the  
AMRL Low Speed Wind Tunnel Data  
Acquisition System**

F.J. Bird

DSTO-TR-1215

**DISTRIBUTION STATEMENT A**  
Approved for Public Release  
Distribution Unlimited

20020710 046

# An Auxiliary Interface Instrumentation Module for the AMRL Low Speed Wind Tunnel Data Acquisition System

*F. J. Bird*

**Air Operations Division**  
Aeronautical and Maritime Research Laboratory

DSTO-TR-1215

## **ABSTRACT**

An IBM PC based electronic module is described which extends the capability of the data acquisition system of the Low Speed Wind Tunnel (LSWT) at the Aeronautical and Maritime Research Laboratory (AMRL). Occasions arise when wind tunnel measurements require external data input or specific data extraction by external or temporarily acquired equipment. Access to the data is provided by the Auxiliary Data Module (ADM). The ADM is one of the VME modules in the LSWT instrumentation console.

The functions of two types of plug-in commercial board are used to provide a suite of digital input and output functions using a total of three boards. Two input, two output and two tachometer channels are provided by two identical I/O boards in addition to the two standard PC RS-232C serial communication ports. The second plug-in board type provides eight analog input channels and two analog output channels with 12 bit resolution.

## **RELEASE LIMITATION**

*Approved for public release*

*Published by*

*DSTO Aeronautical and Maritime Research Laboratory  
506 Lorimer St  
Fishermans Bend, Victoria 3207 Australia*

*Telephone: (03) 9626 7000  
Fax: (03) 9626 7999  
© Commonwealth of Australia 2001  
AR-012-026  
October 2001*

**APPROVED FOR PUBLIC RELEASE**

# An Auxiliary Interface Instrumentation Module for the AMRL Low Speed Wind Tunnel Data Acquisition System

## Executive Summary

An electronic module called the Auxiliary Data Module (ADM) is described which provides the functions required to enable external data input or specific data extraction from the LSWT data acquisition system. The ADM is a PC based unit configured to mechanically conform to the existing console appearance and VME mounting requirements. The module is accessible to the Master computer via the LSWT ethernet network

Auxiliary data may consist of input signals from additional transducers, or data extracted for recording on external devices, or control signals to carry out a remote task.

The ADM provides a suite of user interfaces which include two 16 bit digital input ports, two 16 bit digital output ports, and two dedicated digital input ports for the measurement of tachometer data from powered propellers on wind tunnel models.

In addition, the ADM includes a plug-in analog interface board which provides eight differential analog input channels and two output channels. These analog functions are able to be reconfigured manually by using switches and links on the board for the selection of input and output voltage range and polarity options. All analog I/O channels have 12 bit resolution.

## Authors



**F.J. Bird**

Air Operations Division

*Fred Bird is a Senior Officer (Technical) Grade C who has qualifications equivalent to Certificate of Technology. He has worked in AMRL for 15 years and for Air Operations Division for the last 5 years. He has extensive experience in Data Acquisition in the wind tunnel and Navy helicopter and ship trial environments. He has more recently been involved in human factor research in helicopter night operations.*

---

# Contents

<b>1. INTRODUCTION .....</b>	<b>1</b>
<b>2. MODULE HARDWARE .....</b>	<b>1</b>
<b>2.1 PXB-721 Digital Interface Board .....</b>	<b>3</b>
2.1.1 Digital Interface Connection .....	4
2.1.2 Digital Interface Panel Connector Pin Functions .....	4
2.1.3 Tachometer Input Interface.....	4
2.1.4 Digital Port Connector Allocation.....	5
<b>2.2 PC-74LA Analog Interface Board.....</b>	<b>5</b>
2.2.1 PC-74LA Board Configuration System.....	5
2.2.2 Analog Input Sub-system.....	6
2.2.3 Analog Input Circuit.....	6
2.2.4 Analog Output Sub-system.....	7
<b>2.3 Network Interface Card (NIC).....</b>	<b>7</b>
<b>3. MODULE SOFTWARE .....</b>	<b>7</b>
<b>3.1 ADM Software Initialisation.....</b>	<b>8</b>
3.1.1 3C5X9PD Packet Driver TSR.....	8
3.1.2 Date and Time Synchronisation.....	8
3.1.3 Downloading an Initialisation File.....	9
<b>3.2 ADM General Operation.....</b>	<b>9</b>
3.2.1 Initialisation of the AUXILARY program.....	9
3.2.1.1 The Log File.....	10
3.2.1.2 Read the Initialisation File.....	11
<b>3.3 PC I/O Bus Address Decoding .....</b>	<b>11</b>
<b>3.4 PXB-721 Board Configuration .....</b>	<b>12</b>
<b>3.5 PC-74LA Board Configuration .....</b>	<b>12</b>
3.5.1 PC-74LA Register Structure .....	12
3.5.2 ADGCR.....	13
3.5.3 ADCSR.....	13
3.5.4 ADDAT/DADAT0 (Low Bytes).....	13
3.5.5 ADDAT/DADT0 (High Bytes).....	14
3.5.6 DADAT1 .....	14
3.5.7 TMRCTR.....	14
<b>4. REFERENCES.....</b>	<b>14</b>
<b>5. ACKNOWLEDGEMENTS.....</b>	<b>14</b>

## 1. Introduction

The Auxiliary Data Module (ADM) provides a suite of interface facilities which provide access to data for non standard external monitoring or processing equipment for the Low Speed Wind Tunnel (LSWT) at the Aeronautical and Maritime Research Laboratory (AMRL). The suite includes two digital input ports, two digital output ports, eight analog input ports, two analog output ports, two standard serial communication ports and two additional digital input ports dedicated to tachometer data available from wind tunnel models with powered propellers.

The digital ports are provided by two identical re-configurable commercial plug-in boards. The analog ports are provided by a further commercial plug-in board. The serial ports are the COM 1 and COM 2 ports of the IBM PC platform which is used as a basis for the module.

The ADM operating software consists of C++ version 3.1 modules with the support of the multi-tasking program Real Time Kernel (RTK) version 4.5.

## 2. Module hardware

The ADM is based on a standard IBM PC chassis which has been modified to be contained within VME physical module size standards. Figure 1 shows the module installation.

The usual PC power ON/OFF switching is retained but concealed behind a VME standard panel. Mains power is routed via the module's cooling fan tray which contains the main accessible power switch for the module. This is the normal arrangement for the LSWT data acquisition system.

The interface functions are carried out by commercial plug in boards. Digital I/O uses two identical configurable PXB-721 interface boards. The analog functions use a single PC-74LA analog interface board. Serial communication is conducted using the PC Com ports COM1 and COM2.

A 3COM Etherlink3 ethernet adapter board is used to interface the module to the LSWT ethernet providing accessibility for the master computer.

User interface connections are made on the Auxiliary Interface connector field mounted on a panel at the rear of the VME rack system. Extension cabling connects the panel connectors to the respective interface plug-in boards within the ADM. Figure 2 shows the user connector panel with basic functional explanations. Figure 3 shows the appearance of the panel as seen in the LSWT control room.

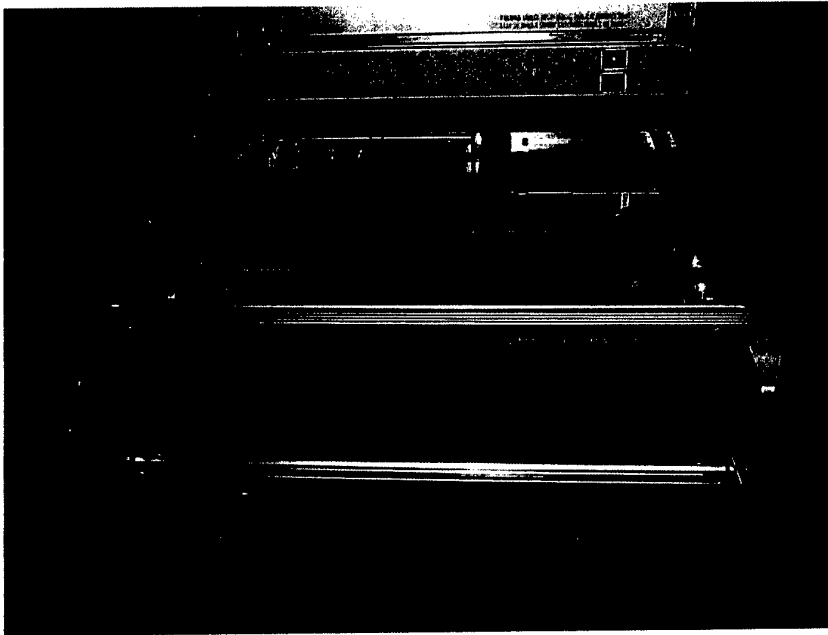

Figure 1: The LSWT Auxiliary Data Module

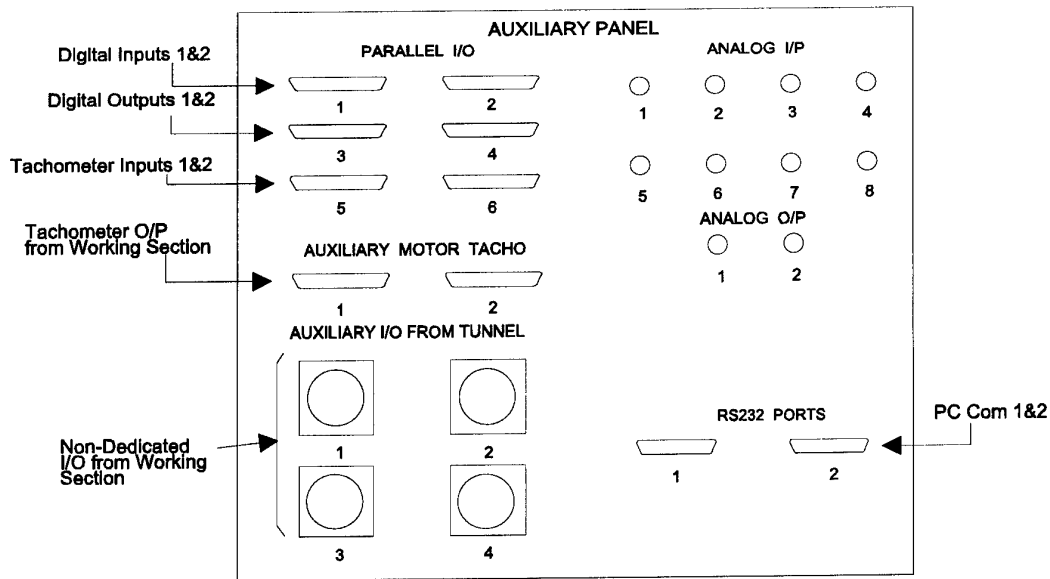

Figure 2: Auxiliary Interface Connector Panel

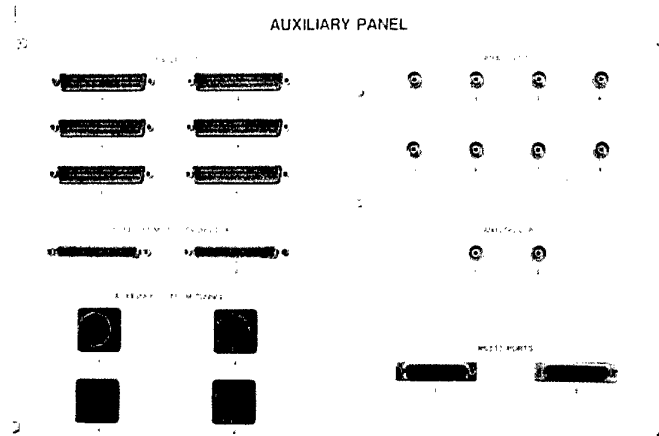

Figure 3: Visual Appearance of the Auxiliary Interface Connector Panel.

## 2.1 PXB-721 Digital Interface Board.

The digital I/O port interface provided by this board consists of 72 digital lines. The board design groups these as a number of 8 bit ports. The 8 bit ports are accessed in pairs as 16 bit ports in the ADM operating software. The ports are provided by three Intel 8255 digital interfacing integrated circuits (IC)<sup>1</sup> per PXB-721 board. The IC devices are mounted on daughter boards plugged to the respective PXB-721 board. In addition, each daughter board has an I/O header connector. The headers are referred to as H1 to H6 paralleling the designations of the ICs. The fact that there are two separate PXB-721 boards means there are six 8255 ICs in all. This report refers to these as IC1 to 3 on Board 1 and IC4 to 6 on Board 2.

Each 8255 IC has three 8 bit ports referred to as A, B & C. The module accesses an A and a B port to make a 16 bit port on each of IC1, 2, 3 & 4 to form the two 16 bit input digital ports and the two 16 bit output digital ports. IC5 & IC6 are used to provide the tachometer input ports. Port A of IC5 and Port A of IC6 are used to provide Tachometer 1 and Tachometer 2 inputs respectively. IC port setting up is done by the ADM software. Data bytes are written to the IC configuration register. Details of this are described in Section 3.4.

For simplicity, polled operation is used to access all the ports. The user of Auxiliary Module digital I/O will refer to these ports simply as Digital Input 1 and 2, Digital Output 1 and 2 or Tachometer 1 and 2.

<sup>1</sup> Intel Microprocessor and Peripheral Handbook Vol.II 1989

### 2.1.1 Digital Interface Connection

The Digital I/O ports on the connector panel are 37 pin D37 male connectors. Female D37 plugs are required to use these ports. The panel sockets are cabled directly to the 8255 header sockets on the daughter boards of each PXB-721 board. To avoid damage to the IC devices due to exceeding absolute voltage and current limits for the 8255 chips, the following limits apply.

Absolute Maximum Voltage: -0.5 to +7 Volts wrt ground.  
 Output Drive Current: 4 mA, this infers a minimum load of 750 ohms.

The interface is nominally TTL compatible and it is therefore quite rugged. The steady state signal characteristics for peripheral application are as follows:

Input Low voltage ( $V_{IL}$ ) -0.5 to 0.8 Volts  
 Input High Voltage ( $V_{IH}$ ) 2.0 to +5  $\pm$  10% Volts  
 Output Low Voltage ( $V_{OL}$ ) 0.45 Volts Max.  
 Output High Voltage ( $V_{OH}$ ) 2.4 Volts Min.

### 2.1.2 Digital Interface Panel Connector Pin Functions

The pin functions of the Digital I/O include digital signal lines and ground reference lines. Table 1 lists the pin numbers and their functions which are applicable to all the Digital I/O D37 connectors.

*Table 1. The pin allocations of the Digital Interface Panel*

Dig.Line	Pin	Dig.Line	Pin
D0	1	D8	14
D1	20	D9	33
D2	2	D10	15
D3	21	D11	34
D4	3	D12	16
D5	22	D13	35
D6	4	D14	17
D7	23	D15	36
Gnd	5	Gnd	32

### 2.1.3 Tachometer Input Interface

The only dedicated function of the ADM is acquiring the model tachometer signals. The 8255 IC chips IC5 and IC6 are used for this purpose. The D37 connectors on the connection

panel designated 5 and 6 are connected to these ICs through headers H5 and H6. The D37 connector pin allocation is identical to Table 1 for the digital I/O functions.

The tachometer signals consist of four digit binary coded decimal (BCD) values. The numbers are serialised at the transmitting ends of the tachometer input signal transmission lines. Each value is received as a serial set of four digits. Each digit is represented as a four bit binary number. The values are converted to hexadecimal values and passed to the Module database via the RTK tasks *ModelTacho1* and *ModelTacho2* which form part of the ADM operating software.

The tachometer signals are cabled to the connector panel from the model in the test section of the wind tunnel and appear on two additional D37 sockets. These signals are linked to the digital I/O input connectors 5 and 6 of the panel using external ribbon link cables on the external face of the connector panel, which is shown in Figure 3.

#### 2.1.4 Digital Port Connector Allocation

The panel connectors allocated to the Digital I/O Ports are listed in Table 2.

Table 2. Allocation of Digital Input/Output Ports.

Digital Port	Connector (D37)
Digital In 1	1
Digital In 2	2
Digital Out 1	3
Digital Out 2	4
Tachometer 1	5
Tachometer 2	6

## 2.2 PC-74LA Analog Interface Board.

### 2.2.1 PC-74LA Board Configuration System

Configuration of this system board is achieved partly by hardware link positions and by software commands which place specific values into board registers. Figure 4 shows the PC74LA plug-in board.

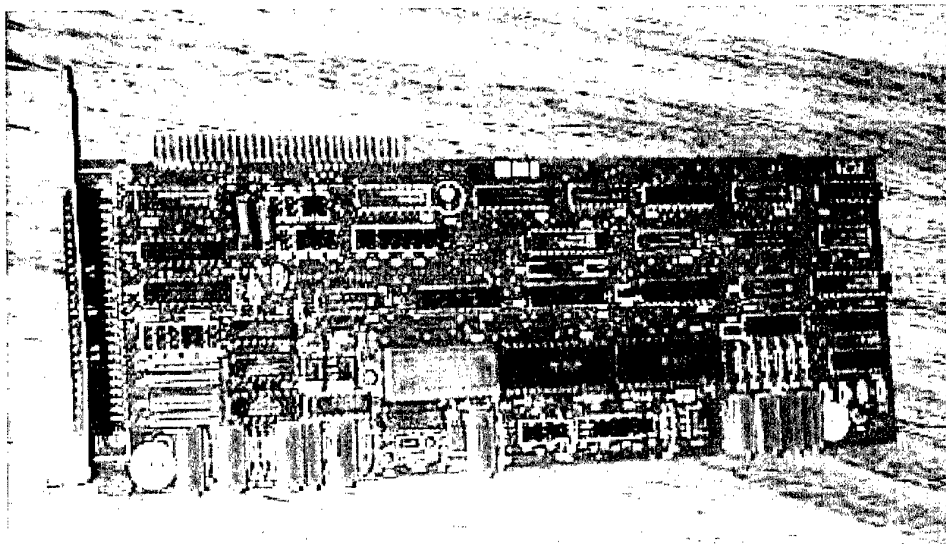

Figure 4: The PC74LA Analog Interface plug-in board

### 2.2.2 Analog Input Sub-system.

The Analog to Digital Converter (ADC) subsystem consists of a monolithic Integrated Circuit (IC) capable of providing 12 bit conversion for 16 multiplexed channels. An instrumentation amplifier with software selectable gain values of 1, 10, 100, 500 isolates the input of the ADC. The ADM program sets the pre-amplifier gain to 1 as a default value. Physical links select input characteristics such as: 8 differential channels or 16 single ended channels;  $\pm 2.5$  V,  $\pm 5$  V bipolar input range or a 0 to 5 V unipolar input range. The default selections are 8 Differential channels, with a  $\pm 5$  V analog I/O range.

Conversion is continuous, and the program uses polled operation. The conversion rate is set by the PC-74 timer software setting.

### 2.2.3 Analog Input Circuit

The PC-74LA board is configured for 8 differential analog channels. The board must have a ground reference which is provided through a resistor of value 7.5 K from the outer line of the insulated coaxial BNC connector to the board's analog ground. This ground is extended from the PC-74LA board I/O header connector to the connector panel by the ribbon extender cables from within the ADM module. The circuit arrangement is shown in Figure 5.

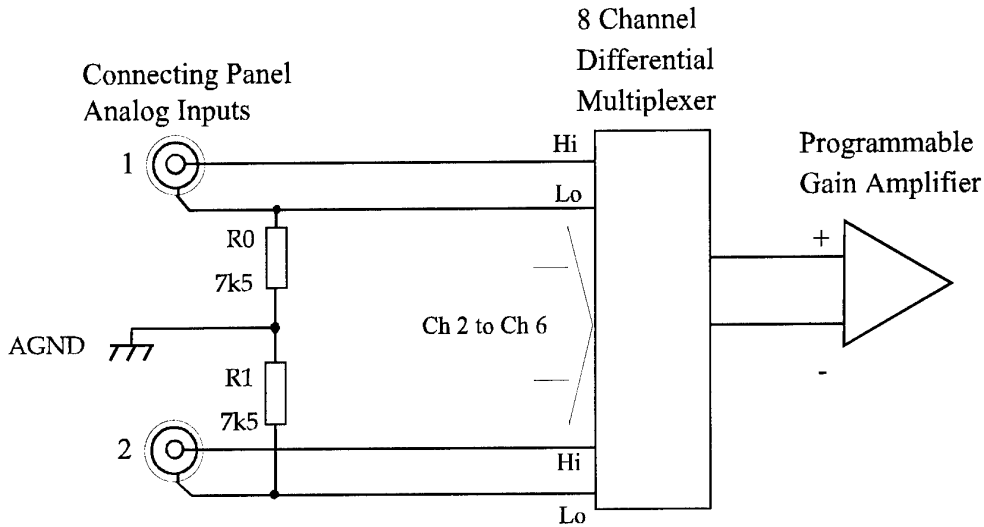

Figure 5: Ground Reference Circuit for the Analog Input Function

#### 2.2.4 Analog Output Sub-system.

Two Digital to Analog Conversion (DAC) ICs provide the two channels of analog output with 12 bit resolution. The output range is hardware selectable. Selections available are  $\pm 5V$ ,  $\pm 2.5V$  and 0 to 5V. The bipolar  $\pm 5V$  option is selected as the default value. The linearity of this sub-system is nominally 0.01% FSR. The Analog output channels are available at two insulated BNC coaxial sockets on the connector panel marked as "Analog Output 1 and 2".

### 2.3 Network Interface Card (NIC)

The ethernet board used for the wind tunnel modules based on the PC platform is the 3COM Etherlink III board. The interrupt level for the ADM ethernet handling is IRQ11.

## 3. Module Software

The operating software consists of C++ version 3.0 modules supported by modules of the multitasking program Real Time Kernel (RTK) version 4.5. The C++ modules include functions to control database access and the plug-in boards, and they use manufacturer's library modules where appropriate.

The C modules are all required to be entered in the C++ project file, AUXILARY.prj, as are library files pertaining to the multi-tasking Real Time Kernel. RTK enables programmers

to minimise waiting during interrupts, communications or other activities. In addition, RTK allows a prioritisation of the program tasks so that important tasks are carried out as required.

On start-up the PC loads the packet driver PKTDRVR.C before using File Transfer Protocol (FTP) to copy the file AUXILARY.INI from the master computer. Following this, the working directory is changed to C:\LSWT\SOFTWARE\AUXILARY to run AUXILARY.EXE.

The module DB\_HNDLR.C calls functions for handling data transfers to or from the module database. Communication packets are formed and decoded by the module PKTDRVR.C. A further program module called ENETDRVR.C contains the ethernet interrupt handling segments. It also receives vector words from the host, passing these on to DB\_HNDLR.C for processing to form the index for host database access.

### **3.1 ADM Software Initialisation.**

The ADM operates in the following way. After the power is turned on or after reset;

1. The module, being a PC, goes through all the normal power-on self testing and then loads MS DOS from the hard drive.
2. The ADM specific functions performed by AUTOEXEC.BAT commands are to load the 3C5X9PD Packet Driver terminate and stay resident (TSR) program, then to synchronise the ADM date and time with that of the master computer on the LSWT network.
3. Finally the initialisation file named AUXILARY.INI is downloaded using FTP from the master computer.

#### **3.1.1 3C5X9PD Packet Driver TSR.**

The 3C5X9PD Packet Driver<sup>2</sup> TSR is a program that makes the ethernet Network Interface Card (NIC) easy for MS DOS programs to use. It provides a consistent set of interface functions to access the NIC hardware. Each NIC manufacturer provides the drivers specific to their NIC. The ADM uses a 3Com Company 3C509 NIC which requires the 3CX9PD TSR driver from 3Com. All the ADM programs which make use of the ethernet network use this packet driver to send and receive information over the network.

#### **3.1.2 Date and Time Synchronisation.**

The modules providing data to the LSWT master computer are all synchronised to the master computer's date and time during initialisation. This allows data packets to be time stamped. It also allows easier cross checking of the log files written to a module's hard

---

<sup>2</sup> More information can be obtained on Packet Drivers from the FAQ at <http://seagull.rtd.com/pub/tcpip/other-faqs/pktdrv.faq>

disk against data files written to the master computer's disk, should that be required. The program PDTSTNET uses the packet driver to send packets to the master computer that ask for the current date and time.

The information returned by the master computer is for UTC and must be corrected by a factor of +10 hours to the local time zone at AMRL, Melbourne (AEST). If daylight saving is in operation, the correction is +11 hours. Once the correction is applied PDTSTNET sets the DOS clock to the local time equivalent of the master computer's date and time.

### 3.1.3 Downloading an Initialisation File.

The master computer partly controls each LSWT Data Acquisition System module's operation through the initialisation files. Much of the ADM operation is controlled by information in a file named AUXILARY.INI. This file is downloaded during every ADM initialisation so that the copy on the ADM hard disk is always up to date with the master file held on the disk of the master computer. The File Transfer Protocol (FTP) is used to reliably copy the file over the network to the ADM disk. The program FTP uses the packet driver to access the network and takes commands from the file FTPINI.CMD in the \LSWT\SOFTWARE\AUXILARY\ directory. These commands enable it to log into the master computer, change to the net/ini directory, and download the AUXILARY.INI file which becomes the latest AUXILARY.INI on the ADM disk. The contents of the AUXILARY.INI file, are dealt with later in Section 3.2 on the main ADM program.

## 3.2 ADM General Operation.

Once the initialisation phase of the AUTOEXEC.BAT file has been done, general operation of the ADM is controlled by the AUXILARY.EXE program. This program also provides the data in the database to any computer on the network that requests it.

Two methods of making the data available to computers external to the ADM are possible. A direct request for an item of data from the database is the first method. The second method is known as "streaming mode". Once the ADM is told to operate in streaming mode it repeatedly broadcasts packets on the network containing all of the parameter data in the local database. Any computer on the network can listen to the broadcast data and make immediate use of it.

### 3.2.1 Initialisation of the AUXILARY program.

The initialisation process consists of recording any error messages in a log file and using data stored in an information (.INI) file, setting up IP addresses for accessing by the master computer and other modules. The initialisation process described in the following paragraphs is depicted in Figure 6.

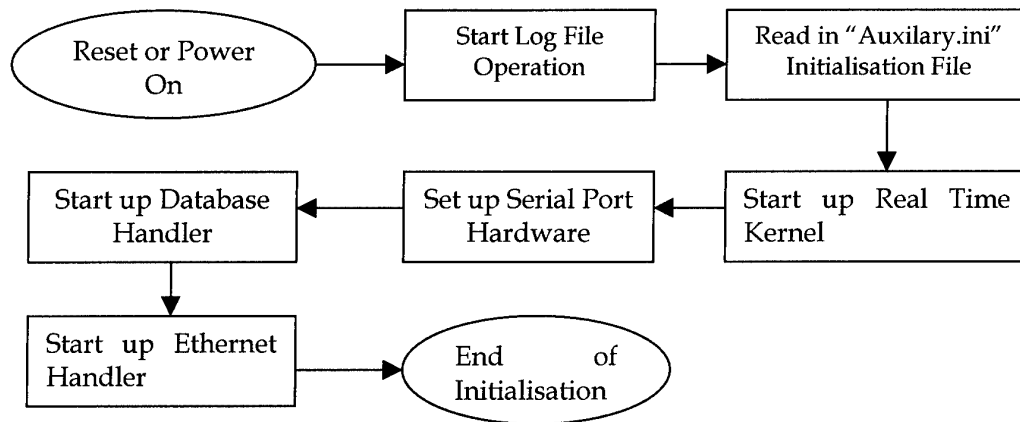

Figure 6: Initialisation Sequence of the AUXILARY program.

### 3.2.1.1 The Log File.

When the AUXILARY program is started it immediately opens a file. Any error messages are written to the file as well as to the screen. Since error messages on the screen are only there for a short time, the file is a more permanent record of a problem or other notable aspects of the ADM operation. The filename is made up from the current date and time that the file is opened. Since date and time cannot be easily placed in a name limited to eight characters the fields are encoded.

The first three letters are taken from the name of the instrumentation module so log files from different modules can be archived in a common directory. In this case the first three letters will be AUX. The next letter of the file name represents the month. This is encoded in hexadecimal (ie base 16) so that January is 0(zero) and December is represented as B. Letter number five in the file name is an encoded representation of the day in the month. The first day of the month is denoted by 1 and day 31 by V.

Effectively, this is encoding to base 32 with an offset of 1. Letter number six in the filename is a base 24 encoding of the hour of the day. The hour just after midnight is represented as 0 (zero) and the hour just before midnight (hour 23) as the letter N. Letter number 7 and letter number 8 are grouped together to show the minute when the file was created. This is not encoded. Minute zero is represented as 00 and minute 59 as 59. The extension for the filename is set to LOG to denote a log file. To clarify this scheme "AUX12345.LOG" would have been created on February 2<sup>nd</sup> at 3:45 AM. Likewise, "AUXBVN59.LOG" corresponds to December 31<sup>st</sup> at 11:59 PM.

### 3.2.1.2 Read the Initialisation File.

The AUXILARY program reads information it requires from a file named "AUXILARY.INI". The information is used to set up the network interface. The network interface is provided with an Internet Protocol (IP) number, an IP address mask, and an IP broadcast address. These allow the module to set up its own local address on the network. Further network related information that is also obtained from the initialisation file is the IP address of the LSWT master computer and the ethernet hardware address of that computer.

However the information provided by the ADM is required by more than just the LSWT master computer and this operational requirement is satisfied by broadcasting ADM information to all devices on the LSWT network. The final piece of network interface information read from the initialisation file is the interrupt number used by the PKTDRVR.C packet driver. This allows the AUXILARY program to send and receive ethernet packets to and from the 3C5X9PD packet driver TSR.

## 3.3 PC I/O Bus Address Decoding

The module AUXILARY.C operates the data acquisition boards to obtain auxiliary data. The boards occupy bus I/O space using the addresses listed in Table 3 for data and port control. The Module program uses the C function SETIOPORTS.C to pass control data to the control registers. The function needs only the boards' base addresses to do this. The control data is defined in the program for each configuration required, ie output or input for the respective ports.

Table 3. Board addresses for data and port control

PXB-721	Base and Data Registers
Board 1 Base	210H
Board 2 Base	220H
Digital In 1	210/218H High Byte 211/219H Low Byte
Digital In 2	214H High Byte 215H Low Byte
Digital Out 1	218/224H High Byte 219/225H Low Byte
Tachometer 1	224/210H
Tachometer 2	228/220H
PC-74LA	Control and Data Registers
Status Reg. ADCSR	310H
Gain.Chan. ADGCR	311H
Conv. Data ADDATL	312H Low Byte
Conv. Data ADDATH	313H High Byte
Dac0 In DADAT0L	312H Low Byte
Dac0 In DADAT0H	313H High Byte
DAC1 In DADAT1L	314H Low Byte
DAC1 In DADAT1H	315H High Byte
Timer Cont. TMRCTR	317H

### 3.4 PXB-721 Board Configuration

Configuring the Digital ports to enable input or output functions is done by passing defined values into the control register within each 8255 IC. This is a function of the Module program AUXILARY.EXE. The Control register AT I/O bus addresses are listed in Table 4.

Table 4: Digital Port addresses on the PXB-721 plug-in board.

IC Device	IC1	IC2	IC3	IC4	IC5	IC6
Register address	213H	217H	21BH	223H	227H	22BH

The configuration options are few. Since only ports A and B of each 8255 IC are to be utilised, the configuration data is listed in Table 5.

Table 5: Configuration data for the Digital Ports.

Option	A,B Input	A,B Output	A Input
Data Value	9BH	80H	90H

The control registers are set to these values by calls to the C function SETIOPORTS in AUXILARY.C.

### 3.5 PC-74LA Board Configuration

The PC-74LA board is configured by a combination of hardware links and program actions. The hardware links are used to set base address, interrupt level, DMA level, DAC output range, Differential or Single-ended input, and the ADC input range.

The hardware setup is considered as fixed. Should a change be required to accommodate a special function in the future the operator is advised to refer to the PC-74LA User Manual.<sup>3</sup>

The PC-74LA board has eight registers to control aspects of configuration and data handling. They are addressed by increments from the base address commencing with the base address.

#### 3.5.1 PC-74LA Register Structure

Eight locations starting with the Board base address in AT I/O space provide the programmable registers of the PC-74LA Board. They are described in Table 6:

<sup>3</sup> Interworld Electronics & Computer Industries (Aust) Pty Ltd

Table 6. Register Locations of the PC-74LA Plug-in Board

Base Offset	Title	Function
0	ADCSR	AD Control/Status
1	ADGCR	AD Gain/Channel Selection
2	ADDAT/DADAT0	Low Byte ADC I/O Data
3	ADDAT/DADAT0	High Byte ADC I/O Data
4	DADAT1	Low Byte DAC1 Data
5	DADAT1	High Byte DAC1 Data
6	DIOP1/DIOP2	This port is unused
7	TMRCTR	Clock Frequency select

### 3.5.2 ADGCR

The lower four bits of this register hold the required channel in binary form. Bits 6 and 7 hold the code for the gain required. Unity gain is set as default. Bits 4 and 5 are not used.

### 3.5.3 ADCSR

The Mode 0 is always the operation mode, no interrupt or DMA is required. The register is read to determine the status of the ADC and if data is available. A write action is required to clear bit 4 if a conversion error occurs. The content of the ADCSR register is described in Table 7.

Table 7. Content of the ADCSR Register.

Bit	Description
0	Bit 0 of Mode Selection (set as 0)
1	Bit 1 of Mode Selection (set as 0)
2	Interrupt Enable Bit (set as 0)
3	DMA Enable Bit (set as 0)
4	A/D Error Clear Bit (write 1 to clear)
5	A/D Busy Flag (during conversion)
6	Set on Conversion Error
7	Set on Conversion Completion

### 3.5.4 ADDAT/DADAT0 (Low Bytes)

This register has a dual function. During ADC operation it contains the low byte of the conversion result. During DAT operation it contains the low byte of the input data word to be loaded into DAC0.

### 3.5.5 ADDAT/DADT0 (High Bytes)

This has the same functioning as ADDAT/DADAT0 except that the high byte of the data is used. A read operation at the end of an ADC conversion clears the conversion completed condition of bit 7 of ADCSR. A DAC conversion is initiated by a write operation to this register.

### 3.5.6 DADAT1

This register holds the low byte of the 12 bit word to be loaded into DAC1 for a DAC conversion and is addressed as base plus offset 4. DADAT1 also holds the high 4 bits of the DAT conversion and this is addressed with offset 5.

### 3.5.7 TMRCTR

The PC-74LA internal clock has a frequency of 600 kHz. This register enables the selection of a suitable divider to provide the preferred frequency. There are 64 selections enabling a wide range of divider values and therefore clock frequencies. Reference to the PC-74LA User Manual is the best means of making a special selection. The default value for the divider is 100 giving a clock frequency of 6 kHz.

## 4. References

Quatech, *Quatech PXB-721 User manual (Rev. B)* Quatech Inc., 662 Wolf Ledges Parkway. Akron, Ohio 44311, USA.

Interworld Electronics, *User Manual for PC-74 (First Ed.)*, 1988. Interworld Electronics & Computer Ind. Aust. P/L., 933 Glenhuntly Road, Caulfield Sth., 3162, Australia.

Intel, *Microprocessor and Peripheral Handbook Vol 2*, Intel Corporation, 3065 Bowers Avenue, Santa Clara, California, 95051, USA.

## 5. Acknowledgements

I would like to acknowledge the assistance of M. Spataro and O. Holland for software advice and the blending in of the ethernet modules, and I. Kerton who wrote the original software modules for the digital port control.

## DISTRIBUTION LIST

An Auxiliary Interface Instrumentation Module for the AMRL Low Speed Wind  
Tunnel Data Acquisition System

F.J.Bird

### AUSTRALIA

#### DEFENCE ORGANISATION

##### S&T Program

Chief Defence Scientist  
FAS Science Policy  
AS Science Corporate Management  
Director General Science Policy Development  
Counsellor Defence Science, London (Doc Data Sheet)  
Counsellor Defence Science, Washington (Doc Data Sheet)  
Scientific Adviser to MRDC Thailand (Doc Data Sheet )  
Scientific Adviser Joint  
Navy Scientific Adviser (Doc Data Sheet and distribution list only)  
Scientific Adviser - Army (Doc Data Sheet and distribution list only)  
Air Force Scientific Adviser  
Director Trials

} shared copy  
}

##### Aeronautical and Maritime Research Laboratory

Director  
Chief of Air Operations Division  
N. Pollock  
N. Matheson (2 copies)  
Task Manager  
Author(s): F.Bird (3 copies)

V. Baskar  
G. Brian  
R. Calderia  
D. Carnell  
J. Clayton  
J. Drobik  
C. Edwards  
L. Erm  
M. Glaister  
A. Gonzales  
S. Lam  
P. Malone  
G. McKenzie  
P. Postle  
H. Quick  
N. Van Bronswijk

B. Woodyatt

**DSTO Library and Archives**

Library Fishermans Bend (Doc Data Sheet )  
Library Maribyrnong (Doc Data Sheet )  
Library Salisbury  
Australian Archives  
Library, MOD, Pyrmont (Doc Data sheet only)  
US Defense Technical Information Center, 2 copies  
UK Defence Research Information Centre, 2 copies  
Canada Defence Scientific Information Service, 1 copy  
NZ Defence Information Centre, 1 copy  
National Library of Australia, 1 copy

**Capability Systems Staff**

Director General Maritime Development (Doc Data Sheet only)  
Director General Aerospace Development (Doc Data Sheet only)

**Knowledge Staff**

Director General Command, Control, Communications and Computers (DGC4)  
(Doc Data Sheet only)

**Army**

Stuart Schnaars, ABCA Standardisation Officer, Tobruk Barracks, Puckapunyal,  
3662 (4 copies)  
SO (Science), Deployable Joint Force Headquarters (DJFHQ) (L), MILPO Gallipoli  
Barracks, Enoggera QLD 4052 (Doc Data Sheet only)

**Intelligence Program**

DGSTA Defence Intelligence Organisation  
Manager, Information Centre, Defence Intelligence Organisation

**Corporate Support Program**

Library Manager, DLS-Canberra

**UNIVERSITIES AND COLLEGES**

Australian Defence Force Academy  
Library  
Head of Aerospace and Mechanical Engineering  
Serials Section (M list), Deakin University Library, Geelong, 3217  
Hargrave Library, Monash University (Doc Data Sheet only)  
Librarian, Flinders University

**OTHER ORGANISATIONS**

NASA (Canberra)  
AusInfo

## OUTSIDE AUSTRALIA

### ABSTRACTING AND INFORMATION ORGANISATIONS

Library, Chemical Abstracts Reference Service  
Engineering Societies Library, US  
Materials Information, Cambridge Scientific Abstracts, US  
Documents Librarian, The Center for Research Libraries, US

### INFORMATION EXCHANGE AGREEMENT PARTNERS

Acquisitions Unit, Science Reference and Information Service, UK  
Library - Exchange Desk, National Institute of Standards and Technology, US  
National Aerospace Laboratory, Japan  
National Aerospace Laboratory, Netherlands

SPARES (5 copies)

**Total number of copies:        64**

<b>DEFENCE SCIENCE AND TECHNOLOGY ORGANISATION DOCUMENT CONTROL DATA</b>				1. PRIVACY MARKING/CAVEAT (OF DOCUMENT)	
2. TITLE An Auxiliary Interface Instrumentation Module for the AMRL Low Speed Wind Tunnel Data Acquisition System			3. SECURITY CLASSIFICATION (FOR UNCLASSIFIED REPORTS THAT ARE LIMITED RELEASE USE (L) NEXT TO DOCUMENT CLASSIFICATION)  Document (U) Title (U) Abstract (U)		
4. AUTHOR(S) F. J. Bird			5. CORPORATE AUTHOR Aeronautical and Maritime Research Laboratory 506 Lorimer St Fishermans Bend Victoria 3207 Australia		
6a. DSTO NUMBER DSTO-TR-1215		6b. AR NUMBER AR-012-026	6c. TYPE OF REPORT Technical Report		7. DOCUMENT DATE October 2001
8. FILE NUMBER M1/9/743	9. TASK NUMBER RDI 98/179	10. TASK SPONSOR DSTO	11. NO. OF PAGES 13		12. NO. OF REFERENCES 3
13. URL on the World Wide <a href="http://www.dsto.defence.gov.au/corporate/reports/DSTO-TR-1215.pdf">http://www.dsto.defence.gov.au/corporate/reports/DSTO-TR-1215.pdf</a>			14. RELEASE AUTHORITY Chief, Air Operations Division		
15. SECONDARY RELEASE STATEMENT OF THIS DOCUMENT  <i>Approved for public release</i>					
OVERSEAS ENQUIRIES OUTSIDE STATED LIMITATIONS SHOULD BE REFERRED THROUGH DOCUMENT EXCHANGE, PO BOX 1500, SALISBURY, SA 5108					
16. DELIBERATE ANNOUNCEMENT  No Limitations					
17. CASUAL ANNOUNCEMENT <span style="float: right;">Yes</span>					
18. DEFTEST DESCRIPTORS  Wind tunnel tests, Aerodynamics, Data Acquisition, Low speed wind tunnels, Modules					
19. ABSTRACT An IBM PC based electronic module is described which extends the capability of the data acquisition system of the Low Speed Wind Tunnel (LSWT) at the Aeronautical and Maritime Research Laboratory (AMRL). Occasions arise when wind tunnel measurements require external data input or specific data extraction by external or temporarily acquired equipment. Access to the data is provided by the Auxiliary Data Module (ADM). The ADM is one of the VME modules in the LSWT instrumentation console.  The functions of two types of plug-in commercial board are used to provide a suite of digital input and output functions using a total of three boards. Two input, two output and two tachometer channels are provided by two identical I/O boards in addition to the two standard PC RS-232C serial communication ports. The second plug-in board type provides eight analog input channels and two analog output channels with 12 bit resolution.					