



DEFENCE



DÉFENSE

# **Extended Kalman Filter Sensor Fusion Signals of Nonlinear Dynamic Systems**

Rahim Jassemi-Zargani and D.S. Neculescu

**DISTRIBUTION STATEMENT A**  
Approved for Public Release  
Distribution Unlimited

**Defence R&D Canada**

TECHNICAL REPORT

DREO TR 2001-155

December 2001



National  
Defence

Défense  
nationale

**Canada**

**20020724 090**

# **Extended Kalman Filter Sensor Fusion Signals Of Nonlinear Dynamic Systems**

Rahim Jassemi-Zargani  
Space Systems and Technology Section  
Defence Research Establishment Ottawa

D.S. Neculescu  
Department of Mechanical Engineering  
University of Ottawa  
Ottawa, Canada

**Defence Research Establishment Ottawa**

Technical Report  
DREO TR 2001-155  
December 2001

AQ F02-10-2207

© Her Majesty the Queen as represented by the Minister of National Defence, 2001

© Sa majesté la reine, représentée par le ministre de la Défense nationale, 2001

## Abstract

---

World modeling for achieving operational space motion control of robot arms requires accurate measurements of positions and velocities in both joint and operational space. Servomotors used for joint actuation are normally equipped with position sensors and, optionally, with velocity sensors for interlink motion measurements. Further improvements in measurement accuracy can be obtained by equipping the robot arm with accelerometers for absolute acceleration measurement. In this report an Extended Kalman Filter is used for multi-sensor fusion. The real-time control algorithm was previously based on the assumption of a jerk represented as a white noise process with zero mean. In reality, the accelerations are varying in time during the arm motion and the zero mean assumption is not valid, particularly during periods of fast acceleration. In this report, a model predictive control approach is used for predetermining next-time-step jerk such that the remaining term can be modeled as Gaussian white noise. Experimental results illustrate the effectiveness of the proposed sensor fusion approach.

## Résumé

---

La modélisation de l'environnement pour le contrôle du mouvement dans l'espace a besoin de mesures précises de la position et de la vitesse tant dans l'espace des articulations que dans l'espace opérationnelle. Les servomoteurs utilisés pour les actionneurs des articulations sont normalement équipés avec des capteurs de position et, en option, avec des capteurs de vitesse pour la mesure du mouvement entre les composants du bras de robot. Des améliorations supplémentaires de la précision de mesure peuvent être obtenues en installant sur le bras du robot des accéléromètres pour la mesure de l'accélération absolue.

Dans ce rapport est utilisé un Filtre Kalman Elargie pour la fusion des capteurs multiples. L'algorithme de contrôle en temps-réel a été, dans le passé, basée sur l'hypothèse que la secousse est représentée comme un processus de bruit blanc avec moyenne zéro. En réalité, les accélérations varient en temps pendant le mouvement du bras et l'hypothèse de moyenne zéro n'est pas correcte, en particulier pendant des périodes d'accélération rapide. Dans ce rapport, une approche de commande prédictive basée sur un modèle est employée pour le précalcul de la secousse du prochain pas de temps d'une telle façon que la composante restante peut être représentée comme bruit blanc gaussienne. Des résultats d'expérience illustrent l'efficacité de l'approche proposée pour la fusion des capteurs.

## Executive summary

---

Operational space motion control of non-linear dynamic system, such as robot arm requires accurate measurements of positions and velocities in both joint and operational space. Servomotors used for joint actuation are normally equipped with position sensors and, optionally, with velocity sensors for interlink motion measurements. Further improvements in measurement accuracy can be obtained by equipping the robot arm with accelerometers for absolute acceleration measurement.

The implementation of the control system such as an impedance controller requires operational space linearization based on the computed torque approach. Extensive work has been carried out to improve the computed torque approach for robot motion control by using different types of parameter identification methods, by modelling the unknown dynamics, and by developing more robust controllers. In general, analytically computed torque has been often considered computationally prohibitive for real time controller implementation.

In this paper, further improvements to the operational space impedance control are proposed using various computationally efficient methods. First, a perturbation observer is used to obtain an approximation of the joint linearization torque value. The perturbation observer uses a combination of time delay and acceleration tracing methods for estimating non-inertial torques. The perturbation observer requires an accurate joint acceleration estimation obtained from measurements and computations. The computation of acceleration by numerical derivation of the joint position is possible due to the availability of high resolution joint position sensors. Joint acceleration can be obtained by kinematic computations using the measurement of absolute acceleration. Combining the end-effector accelerometer signals and joint position sensors signals can give an acceleration estimate with higher bandwidth than each separately.

To improve the accuracy and bandwidth of the signals, an Extended Kalman Filter is used for multi-sensor fusion. The real-time control algorithm was previously based on the assumption of a jerk represented as a processed white noise with zero mean. In reality, the accelerations are varying in time during the arm motion and the zero mean assumption is not valid, particularly during periods of fast accelerating. In this report, a model predictive control approach is used for predetermining next-time-step jerk such that the remaining term can be modeled as Gaussian white noise.

The experimental results shown in this report, illustrates the effectiveness of the proposed sensor fusion approach (Extended Kalman Filter) in real time.

Jassemi-Zargani, R.; Neculescu, D. 2001. Extended Kalman Filter Sensor Fusion signals of Nonlinear Dynamic Systems. DREO TR 2001-155, Defence Research Establishment Ottawa.

## Sommaire

---

Le contrôle du mouvement dans l'espace opérationnel d'un système nonlinéaire, comme par exemple un bras de robot, a besoin de mesures précises de la position et de la vitesse tant dans l'espace des articulations que dans l'espace opérationnel. Les servomoteurs utilisés pour les actionneurs des articulations sont normalement équipés avec des capteurs de position et, en option, avec des capteurs de vitesse pour la mesure du mouvement entre les composants du bras de robot. Des améliorations supplémentaires de la précision de mesure peuvent être obtenues en installant, sur le bras du robot, des accéléromètres pour la mesure de l'accélération absolue.

La réalisation du système de contrôle, comme par exemple le système de contrôle d'impédance, a besoin de la linéarisation dans l'espace opérationnel basée sur l'approche de l'évaluation du couple. Beaucoup de travail a été fait pour l'amélioration de l'approche de l'évaluation du couple pour le contrôle du mouvement du robot en utilisant une variété de méthodes d'identification des paramètres, en modélisant la dynamique inconnue et en développant des systèmes de contrôle plus robuste. En général, l'évaluation analytique du couple a été souvent considérée comme trop difficile du point de vue du poids de calculs pour la réalisation d'un système de contrôle en temps réel.

Dans cet article, des améliorations supplémentaires au système de contrôle prédictif, basées sur un modèle dans l'espace opérationnel, sont proposées en utilisant diverses méthodes efficaces du point de vue de l'effort de calcul. Au début, un observateur de la perturbation est employé pour obtenir une approximation de la valeur du couple de linéarisation dans l'espace des articulations. L'observateur de la perturbation est basé sur une combinaison des méthodes du délai en temps et du trajet de l'accélération pour estimer le couple non-inertial.

L'observateur de la perturbation a besoin de l'estimation de l'accélération de l'articulation obtenue à partir des mesures et des calculs. Le calcul de l'accélération par différentiation numérique de la position de l'articulation, disponible à partir des capteurs de haute résolution de la position de l'articulation. L'accélération de l'articulation peut être obtenue par calculs cinématiques, en utilisant les mesures de l'accélération absolue. La combinaison des signaux de l'accéléromètre de l'outil du robot et des signaux des capteurs de position des articulations peut donner une estimation de l'accélération avec une bande passante plus élevée que chacun séparément.

Pour améliorer la précision et la bande passante des signaux, un Filtre Kalman Elargie est utilisé pour la fusion des capteurs multiples. L'algorithme de contrôle en temps-réel a été, dans le passé, basé sur l'hypothèse que la secousse est représentée comme un processus de bruit blanc avec moyenne zéro. En réalité, les accélérations varient en temps pendant le mouvement du bras et l'hypothèse de moyenne zéro n'est pas correcte, en particulier pendant des périodes d'accélération rapide. Dans ce rapport, une approche de commande prédictive basée sur un modèle est employée pour le précalcul de la secousse du prochain pas de temps d'une telle façon que la composante restante peut être représentée comme un bruit blanc gaussien. Des résultats d'expérience illustrent l'efficacité de l'approche proposée (Filtre Kalman Elargie) pour la fusion des capteurs.

Jassemi-Zargani, R.; Neculescu, D. 2001 Extended Kalman Filter Sensor Fusion signals of Nonlinear Dynamic Systems. DREO TR 2001-155, Centre de recherches pour la défense Ottawa.

## Table of contents

---

|   |      |
|---|------|
| Abstract .....  | i    |
| Résumé.....   | ii   |
| Executive summary.....  | iii  |
| Sommaire .....  | iv   |
| Table of contents .....   | v    |
| List of figures .....   | vii  |
| List of tables .....  | viii |
| 1. Introduction.....  | 1    |
| 2. Computational Efficiency of Impedance Controller Schemes .....   | 2    |
| 3. Acceleration Perturbation Observer .....   | 5    |
| 4. Joint Acceleration Measurement and Estimation .....  | 7    |
| 5. Sensor Fusion Using Extended Kalman Filter for Acceleration Evaluation.....  | 8    |
| 5.1 Linearization of output equations .....   | 11   |
| 5.2 Extended Kalman Filter algorithm.....   | 13   |
| 6. Experimental Set-Up .....  | 14   |
| 7. Experimental Results .....   | 15   |
| 7.1 Joint acceleration estimation .....   | 15   |
| 7.2 Impedance control of single arm using acceleration estimation .....   | 15   |
| 7.3 Experimental results of robot arm impedance control using an Extended<br>Kalman Filter based on sensor fusion ..... | 17   |
| 8. Conclusions and Recommendations .....  | 18   |
| 9. References.....  | 19   |

List of symbols/abbreviations/acronyms/initialisms..... 20

## List of figures

---

|  |    |
|--|----|
| Figure 1. Two-part Impedance controller.....   | 3  |
| Figure 2. Three-part Impedance controller.....   | 4  |
| Figure 3. Impedance controller with a perturbation observer.....   | 6  |
| Figure 4. Impedance controller using EKF sensor fusion.....  | 8  |
| Figure 5. Experimental set-up.....   | 14 |
| Figure 6. Experimental and estimation results for joint acceleration, double numerical derivative of joint position measurement using equation (16), joint acceleration calculation using equation (17) and accelerometer signals, fusion of (A) and (B) results using EKF. .... | 15 |
| Figure 7. Experimental results for end-effector trajectories for: (a) analytical computation of all dynamic terms, (b) joint observer plus analytical computation of all dynamic terms, (c) PD operation of space control, (d) same as (b) without analytical computation .....  | 16 |
| Figure 8. End-effector trajectory of robot arm based on two methods: (a) second derivative of joint positions and (b) EKF in parallel with approximate compensation models of dynamic terms.....   | 17 |

## List of tables

---

|  |   |
|--|---|
| Table 1. Comparison of two-part and three-part impedance controllers ..... | 4 |
|--|---|

# 1. Introduction

---

Extensive research has been carried for the purpose of achieving accurate operational space sensing and motion control of robot arms. S. Komada and K. Ohinishi [1] proposed a first order lag filter as a perturbation observer for the estimation of the unknown dynamics terms used for linearization. T.C. Hsia [2] and K. Youcef-Toumi [3] presented a similar method called the time-delay method, for obtaining the compensation terms. Hsia [2] suggested a simple approach which basically uses the input and output torques of robot joints. For short time delay, the difference of these torques is added to the next torque input; this is feasible as long as the sampling time is very small. Robust controllers were designed to overcome the effect of some of the unknown dynamics terms. Adaptation of an impedance controller is proposed by W.S. Lu [4]. Also, an integral term for improving the robustness of impedance controller was considered by G.J. Liu and A.A. Goldenberg [5]. Perturbation observers require the joint acceleration feedback signal and joint accelerations can be measured or calculated. The calculation by numerical derivation of joint position assumes that high resolution joint sensors are available. Because of high frequency noise and other numerical problems, this signal requires a low pass filter. Combining the end-effector accelerometers and joint position sensors can give an acceleration estimate with higher bandwidth than each separately. Sensor fusion between two sensors (accelerometers and resolvers) has been proposed in [6,7].

The contributions to the integration of multiple sensors into a robotic system are surveyed in [8]. A hierarchical integration of multiple sensors into an existing system is proposed and evaluated. The methods for sensory data integration are not analyzed. A methodological analysis of Kalman filter and set-based approaches for sensor data fusion is presented in [9]. Experimental evaluation leads to the conclusion that the performance of each approach is problem dependent. In the methodological analysis of paper [9] and in books [10] and [11], the data fusion refer mainly to complex static (geometric) environmental data while the data fusion problem in this report refers to less complex but time varying (kinematics) data.

The literature review shows that at the present time the estimation of kinematic state variables of a dynamic model using data fusion from various sensors has been approached in an elaborate form only using Extended Kalman Filter method [12-13]. This method is proposed for the data fusion for state estimation of manipulators considered in this report.

A complete 3D virtual reality model for robotic systems is useful for motion visualization, however, for the operational space robot arm motion control an abstract world model, containing only joint and Cartesian motion variables, is sufficient [7, 14]. A proposed Kalman filter for obtaining an accelerometer signal was based on a kinematic model with a jerk assumed equivalent to a white noise source [15]. This paper presents a model predictive control approach for replacing the pure white noise jerk assumption by a more realistic model containing a model-based predicted part and a Gaussian white noise part.

## 2. Computational Efficiency of Impedance Controller Schemes

---

Figure 1 shows a standard two-part impedance control scheme consisting of a Cartesian decoupling part and a linear control law part [7]. The Cartesian decoupling part is described by:

$$\tau = J^T(\theta) \left( M_x(\theta) \ddot{X} + V_x(\theta, \dot{\theta}) + G_x(\theta) + F_x(\theta, \dot{\theta}) + F_{ext} \right) \quad (1)$$

and contains the components  $[M_x(\theta), V_x(\theta, \dot{\theta}), G_x(\theta), F_x(\theta, \dot{\theta})]$ , which contain both kinematic and dynamic parameters of the robot [8]:

$$\begin{aligned} M_x(\theta) &= J^{-T}(\theta) M(\theta) J^{-1}(\theta) \\ V_x(\theta, \dot{\theta}) &= J^{-T}(\theta) [V(\theta, \dot{\theta}) - M(\theta) J^{-1}(\theta) \dot{J}(\theta) \dot{\theta}] \\ G_x(\theta) &= J^{-T}(\theta) G(\theta) \\ F_x(\theta, \dot{\theta}) &= J^{-T}(\theta) \tau_n(\theta, \dot{\theta}) \end{aligned} \quad (2)$$

where:

|                                |   |
|--------------------------------|---|
| $\theta$                       | the vector of angular joint positions                           |
| $\dot{\theta}$                 | the vector of angular joint velocities                          |
| $M_x(\theta)$                  | inertia matrix in Cartesian space                               |
| $M(\theta)$                    | inertia matrix in joint space                                   |
| $V_x(\theta, \dot{\theta})$    | the vector of centrifugal and Coriolis terms in Cartesian space |
| $V(\theta, \dot{\theta})$      | the vector of centrifugal and Coriolis terms in joint space     |
| $G_x(\theta)$                  | the vector gravity term in Cartesian Space                      |
| $G(\theta)$                    | the vector gravity term in joint space                          |
| $F_x(\theta, \dot{\theta})$    | the vector friction term in Cartesian space                     |
| $\tau_n(\theta, \dot{\theta})$ | the vector of friction term in joint space                      |

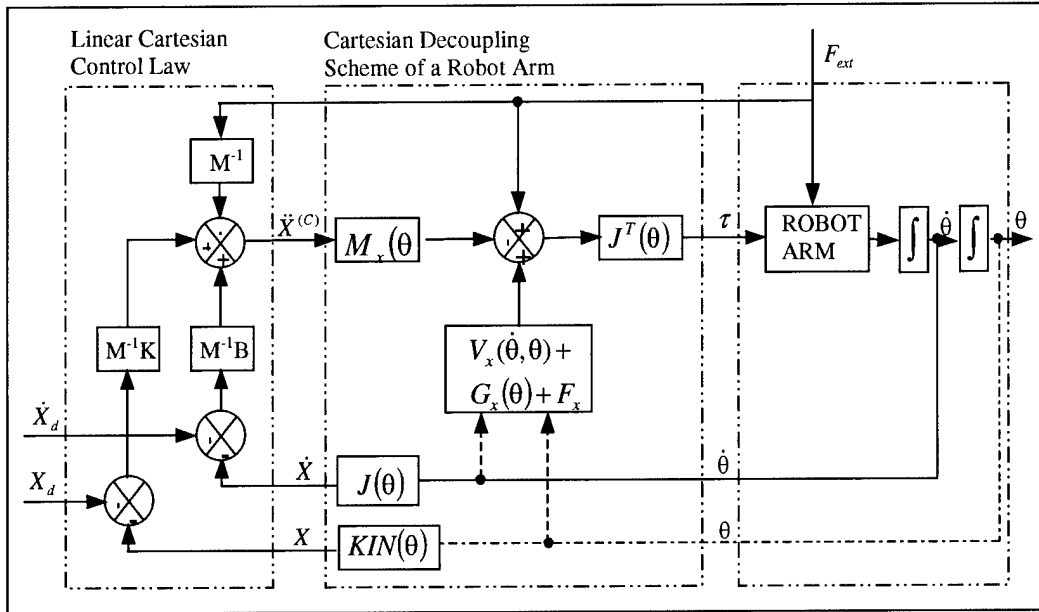

Figure 1. Two-part Impedance controller

Figure 2 shows a three-part control scheme in which the nonlinear compensator is further split into two parts, a joint decoupling scheme and the Cartesian decoupling scheme for a joint decoupled robot arm [7]. In the later case, the Cartesian decoupling scheme contains only the kinematics equation:

$$\ddot{\theta}_c = J^{-1}(\ddot{X}^{(c)} - \dot{J}\dot{\theta}) \quad (3)$$

while the joint decoupling scheme contains all the joint dynamics equations given by the joint torque equation:

$$\tau = M(\theta)\ddot{\theta}^{(c)} + \Delta\tau \quad (4)$$

where the non-inertial dynamic terms are:

$$\Delta\tau = V(\dot{\theta}, \theta) + G(\theta) + \tau_n(\theta, \dot{\theta}) + J^T(\theta)F_{ext} \quad (5)$$

A comparison of computational requirements for two and three-part impedance controllers is presented in Table 1. Computation of Part (a), (Linear Cartesian Control Law), and external force ( $f_{ext}$ ) is not considered, because they are the same in both controllers. The results from Table 1 show that the three-part controller has a better computational efficiency than the two-part controller. In this paper the impedance

controller is based on the three-part control scheme because the methods proposed use the explicit joint space linearization scheme.

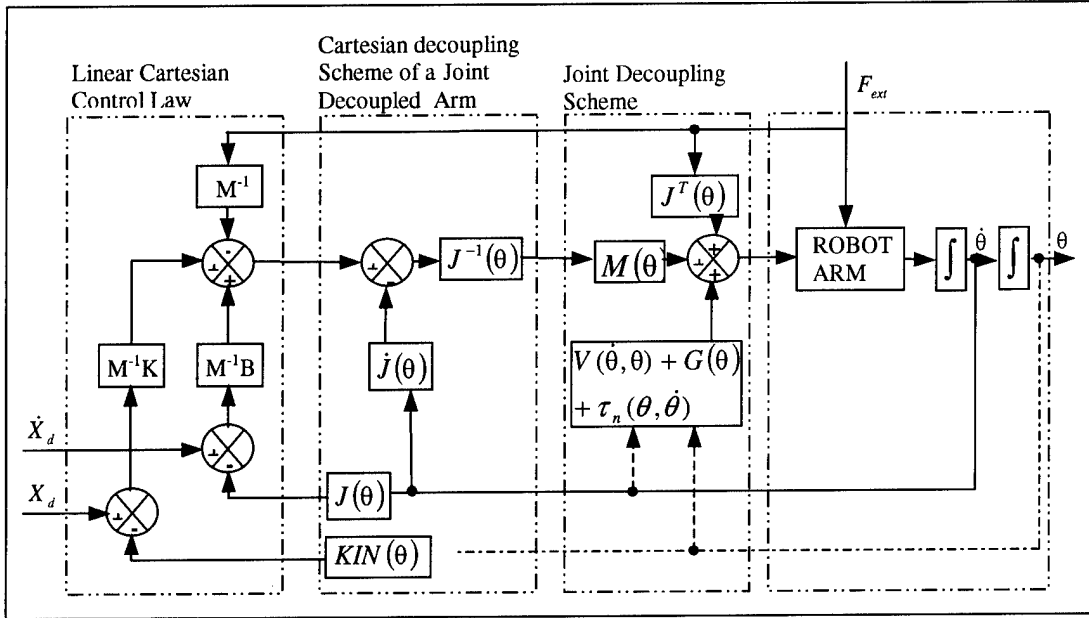

Figure 2. Three-part Impedance controller

Table 1. Comparison of two-part and three-part impedance controllers

| Description   | Two-Part Impedance Controller | Three-Part Impedance Controller |
|---|-------------------------------|---------------------------------|
| Calculation of the Inverse of the Jacobian              | 1                             | 1                               |
| Calculation of the Transpose of Inverse of the Jacobian | 1                             | 0                               |
| Calculation of the Derivative of the Jacobian           | 1                             | 1                               |
| Use of the Inverse of the Jacobian                      | 2                             | 1                               |
| Use of the Transpose of Inverse of the Jacobian         | 4                             | 0                               |
| Use of the Derivative of the Jacobian                   | 1                             | 1                               |
| Multiplication: Matrix-Matrix                           | 2                             | 0                               |
| Multiplication: Matrix-Vector                           | 8                             | 3                               |
| Addition: Vector-Vector                                 | 4                             | 4                               |

### 3. Acceleration Perturbation Observer

---

The dynamic model for a rigid link robot arm is given by:

$$\tau = M(\theta)\ddot{\theta} + \Delta\tau \quad (6)$$

where  $\Delta\tau$  is given by equation (5). The non-inertial dynamic part  $\Delta\tau$  of the joint decoupling scheme can be estimated using a perturbation observer [1-3]. Equation (6) can also be written as:

$$M^{-1}(\theta)\tau = \ddot{\theta} + M^{-1}(\theta)\Delta\tau \quad (7)$$

Expanding the last term as:

$$\Delta\ddot{\theta} = M^{-1}(\theta)\Delta\tau \quad (8)$$

equation (5) gives, for the time  $t - \Delta t$ ,

$$\Delta\ddot{\theta}(t - \Delta t) = M^{-1}(\theta(t - \Delta t))\tau(t - \Delta t) - \ddot{\theta}(t - \Delta t) \quad (9)$$

Given, that in this work, accelerations, not torques, are measured, the last equation is used as an indirect observer of the non-inertial terms,  $\Delta\tau$  [7]. For a relatively short  $\Delta t$  the non-inertial torque terms,  $\Delta\tau$ , and inertia matrix can be assumed constant:

$$\Delta\tau(t) \approx \Delta\tau(t - \Delta t) \quad (10)$$

$$M(\theta(t)) \approx M(\theta(t - \Delta t)) \quad (11)$$

such that:

$$\Delta\ddot{\theta}(t) \approx \Delta\ddot{\theta}(t - \Delta t) \quad (12)$$

Using  $\Delta\tau$  from equation (5) in equation (8) gives:

$$\Delta\ddot{\theta} = M^{-1}(\theta)[V(\theta, \dot{\theta}) + \tau_n(\theta, \dot{\theta}) + G(\theta) + J^T(\theta)F_{ext}] \quad (13)$$

This confirms that non-inertial torque terms can be indirectly estimated using an acceleration observer for  $\Delta\ddot{\theta}$ . After equating  $\ddot{\theta}$  with the computed acceleration  $\ddot{\theta}^{(c)}$ , equation (6) and (8) give:

$$\tau = M(\theta)(\ddot{\theta}^{(c)} + \Delta\ddot{\theta}) \quad (14)$$

Finally, equation (9),(12) and(14) result in a perturbation observer for  $\Delta\ddot{\theta}$  :

$$\Delta\ddot{\theta}(t) \approx \ddot{\theta}^{(c)}(t - \Delta t) + \Delta\ddot{\theta}(t - \Delta t) - \ddot{\theta}(t - \Delta t) \quad (15)$$

The block diagram shown in Figure 3 details the impedance controller using a perturbation observer for  $\Delta\ddot{\theta}$ , i.e. indirectly for non-inertial torque terms.

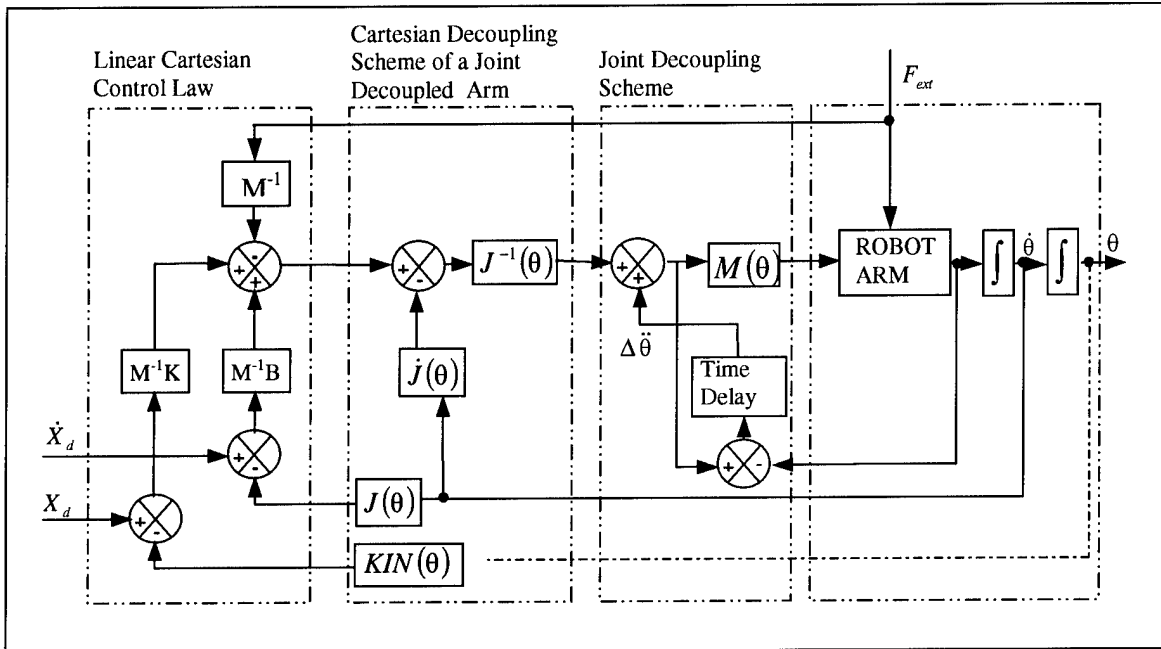

Figure 3. Impedance controller with a perturbation observer

In Figure 3, equation (15) is used to obtain the input for the Time Delay block and equation (14) gives the torque command of the joint decoupling scheme.

## 4. Joint Acceleration Measurement and Estimation

---

For the method presented in the previous section, joint acceleration has to be accurately estimated. There are different concurrent ways to obtain this estimation; sensor fusion was selected for to obtain estimations based on the results from relative link positions and absolute link acceleration measurements. This choice of sensors is a result of the availability of sensors for the measurement of relative angular displacement of robot links (using high resolution resolvers or optical encoders) and absolute link acceleration using accelerometers. By numerical derivation of joint position, relative acceleration can be obtained using backward approximation:

$$\ddot{\theta}(t) = \frac{\theta(t - 2\Delta t) - 2\theta(t - \Delta t) + \theta(t)}{2\Delta t} \quad (16)$$

Absolute accelerations can be measured using accelerometers installed on the robot links.

Joint accelerations are obtained from link accelerometer signals and the estimated joint speed using the kinematic equation of the accelerations. For  $\theta$ , the vector of the joint angular positions, and  $x$ , the vector of the Cartesian accelerations, joint acceleration  $\ddot{\theta}$  can be calculated from the kinematic equation for a rigid link robot with revolute joints:

$$\ddot{\theta} = J^{-1}(\theta)[\ddot{x} - \dot{J}(\theta)\dot{\theta}] \quad (17)$$

where:

$\dot{\theta}$             joint velocities vector  
 $J$              Jacobian matrix

## 5. Sensor Fusion Using Extended Kalman Filter for Acceleration Evaluation

A suitable method for sensor fusion of accelerometer and resolver outputs is the Extended Kalman Filter (EKF). EKF proved suitable for real time estimation of kinematic variables given the presence of the noise and the non-linearity of the robot arm dynamics. For nonlinear systems, an EKF can estimate the states of non-linear systems using a linearized approximation based on current state estimate [12]. Figure 4 shows the block diagram of the robot controller using EKF for the estimation of  $\ddot{\theta}$  and  $\dot{\theta}$ .

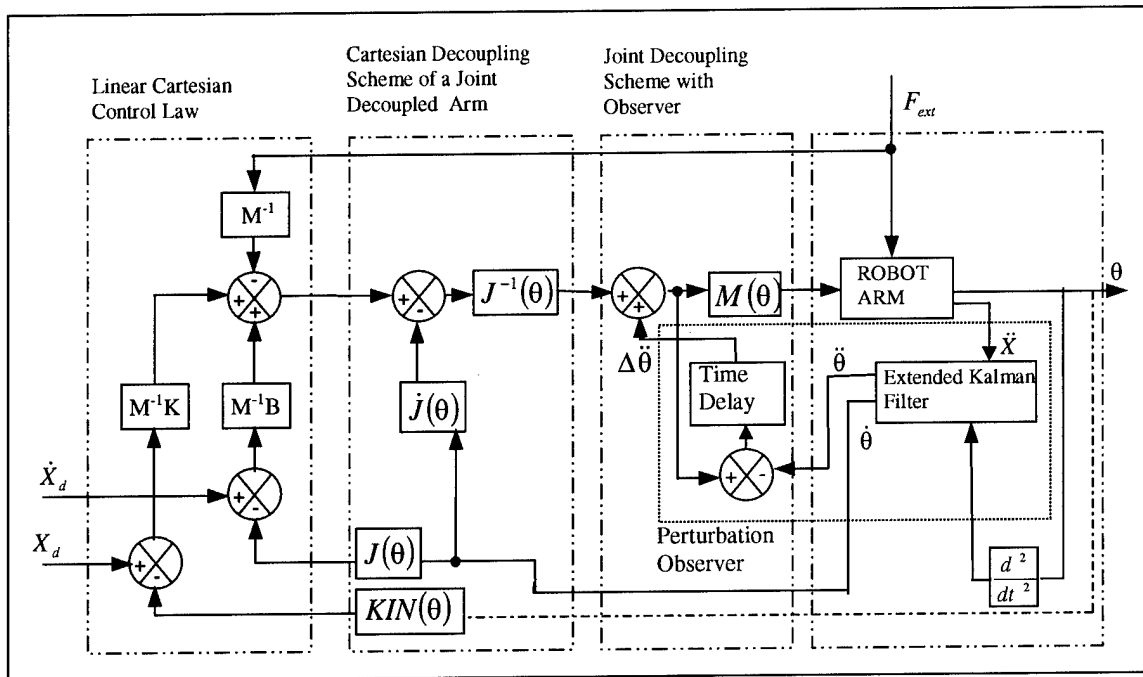

Figure 4. Impedance controller using EKF sensor fusion

For a two degree-of-freedom revolute robot arm, given joint one and two angular positions  $\theta_1$  and  $\theta_2$ , the states are defined as:

$$\begin{aligned}
x_1 &= \theta_1 \\
x_2 &= \theta_2 \\
x_3 &= \dot{x}_1 = \dot{\theta}_1 \\
x_4 &= \dot{x}_2 = \dot{\theta}_2 \\
x_5 &= \dot{x}_3 = \ddot{\theta}_1 \\
x_6 &= \dot{x}_4 = \ddot{\theta}_2
\end{aligned} \tag{18}$$

The jerks,  $\dot{x}_5$ , and,  $\dot{x}_6$ , are assumed time independent white noise processes  $V_1$  and  $V_2$ , respectively. State equations are:

$$\begin{aligned}
\dot{x}_1 &= x_3 \\
\dot{x}_2 &= x_4 \\
\dot{x}_3 &= x_5 \\
\dot{x}_4 &= x_6 \\
\dot{x}_5 &= V_1 \\
\dot{x}_6 &= V_2
\end{aligned} \tag{19}$$

The noisy measurements,  $y_1$ , and,  $y_2$ , of angular positions  $\theta_1$  and  $\theta_2$  are modeled by the following measurement equations:

$$\begin{aligned}
y_1 &\approx x_1 + w_1 \\
y_2 &\approx x_2 + w_2
\end{aligned} \tag{20}$$

The noisy measurements,  $y_3$ , and  $y_4$ , of the Cartesian accelerations are used in measurement equations based on the kinematic equation.

$$\ddot{x} = J(\theta)\ddot{\theta} + \dot{J}(\theta)\dot{\theta} \tag{21}$$

or, using above defined states,

$$\begin{bmatrix} y_3 \\ y_4 \end{bmatrix} = J(x_1, x_2) \begin{bmatrix} x_5 \\ x_6 \end{bmatrix} + \dot{J}(x_1, x_2, x_3, x_4) \begin{bmatrix} x_3 \\ x_4 \end{bmatrix} + \begin{bmatrix} w_3 \\ w_4 \end{bmatrix} \tag{22}$$

where [7,8]:

$$J(x_1, x_2) = \begin{bmatrix} J_{11} & J_{12} \\ J_{21} & J_{22} \end{bmatrix}$$

$$\dot{j}(x_1, x_2, x_3, x_4) = \begin{bmatrix} \dot{J}_{11} & \dot{J}_{12} \\ \dot{J}_{21} & \dot{J}_{22} \end{bmatrix}$$

State equations in matrix form are:

$$\begin{aligned} x &= Ax + BV \\ y &= Cx + w \end{aligned} \tag{23}$$

where:

$$A = \begin{bmatrix} 0 & 0 & 1 & 0 & 0 & 0 \\ 0 & 0 & 0 & 1 & 0 & 0 \\ 0 & 0 & 0 & 0 & 1 & 0 \\ 0 & 0 & 0 & 0 & 0 & 1 \\ 0 & 0 & 0 & 0 & 0 & 0 \\ 0 & 0 & 0 & 0 & 0 & 0 \end{bmatrix} \quad B = \begin{bmatrix} 0 & 0 & 0 & 0 & 0 & 0 \\ 0 & 0 & 0 & 0 & 0 & 0 \\ 0 & 0 & 0 & 0 & 0 & 0 \\ 0 & 0 & 0 & 0 & 0 & 0 \\ 0 & 0 & 0 & 0 & 1 & 0 \\ 0 & 0 & 0 & 0 & 0 & 1 \end{bmatrix}$$

$$C = \begin{bmatrix} 1 & 0 & 0 & 0 & 0 & 0 \\ 0 & 1 & 0 & 0 & 0 & 0 \\ 0 & 0 & \dot{J}_{11} & \dot{J}_{21} & J_{11} & J_{12} \\ 0 & 0 & \dot{J}_{21} & \dot{J}_{22} & J_{21} & J_{22} \end{bmatrix}$$

$$\begin{aligned} x &= [x_1 \quad x_2 \quad x_3 \quad x_4 \quad x_5 \quad x_6]^T \\ \dot{x} &= [\dot{x}_1 \quad \dot{x}_2 \quad \dot{x}_3 \quad \dot{x}_4 \quad \dot{x}_5 \quad \dot{x}_6]^T \\ y &= [y_1 \quad y_2 \quad y_3 \quad y_4]^T \\ V &= [0 \quad 0 \quad 0 \quad 0 \quad V_1 \quad V_2]^T \\ w &= [w_1 \quad w_2 \quad w_3 \quad w_4]^T \end{aligned}$$

The state equations of the system, for short sampling time(  $\Delta t$  ), can be written as:

$$\begin{aligned} x(n+1) &= ax(n) + bv(n) \\ y(n) &= cx(n) + w(n) \end{aligned} \tag{24}$$

where:

$$a \approx I + TA = \begin{bmatrix} 1 & 0 & T & 0 & 0 & 0 \\ 0 & 1 & 0 & T & 0 & 0 \\ 0 & 0 & 1 & 0 & T & 0 \\ 0 & 0 & 0 & 1 & 0 & T \\ 0 & 0 & 0 & 0 & 1 & 0 \\ 0 & 0 & 0 & 0 & 0 & 1 \end{bmatrix} \quad b \approx TB = \begin{bmatrix} 0 & 0 & 0 & 0 & 0 & 0 \\ 0 & 0 & 0 & 0 & 0 & 0 \\ 0 & 0 & 0 & 0 & 0 & 0 \\ 0 & 0 & 0 & 0 & 0 & 0 \\ 0 & 0 & 0 & 0 & T & 0 \\ 0 & 0 & 0 & 0 & 0 & T \end{bmatrix}$$

$v(n) = V$

## 5.1 Linearization of output equations

The measurement equations for  $y_1$  and  $y_2$  are linear:

$$y_1 = x_1 + w_1 \tag{25}$$

$$y_2 = x_2 + w_2$$

The output equations for  $y_3$  and  $y_4$  are nonlinear and, in order to apply EKF, these equations have to be linearized. The linearized version of the non-linear equation is:

$$y(t) = h(x(t), u(t), w(t)) \tag{26}$$

is obtained, by linearizing equation (26) about the current estimation  $\hat{x}(t)$  of the state vector ( $x(t) = \hat{x}(t), w(t) = 0$ ) [12]. The following linear equation is thus obtained:

$$y(t) \cong h(\hat{x}(t), u(t), 0) + H(t)[x(t) - \hat{x}(t)] + G(t)w \tag{27}$$

where:

$$H(t) = \frac{\partial h(x(t), u(t), w(t))}{\partial x(t)} \tag{28}$$

$$G(t) = \frac{\partial h(x(t), u(t), w(t))}{\partial w(t)}$$

The measurement equation for  $y_3$  is linearized as follows [6,7]:

$$\begin{aligned}
y_3 &= y_3(\hat{x}) + \left. \frac{\partial y_3}{\partial x} \right|_{x=\hat{x}} (x - \hat{x}) \\
&= \dot{J}_{11}(\hat{x})\hat{x}_3 + \dot{J}_{12}(\hat{x})\hat{x}_4 + J_{11}(\hat{x})\hat{x}_5 + J_{12}(\hat{x})\hat{x}_6 + w_3 \\
&+ \left[ \frac{\partial(\dot{J}_{11})}{\partial x} \hat{x}_3 + \frac{\partial(\dot{J}_{12})}{\partial x} \hat{x}_4 + \frac{\partial(J_{11})}{\partial x} \hat{x}_5 + \frac{\partial(J_{12})}{\partial x} \hat{x}_6 \right] [x - \hat{x}] \\
&+ \left[ \dot{J}_{11} \frac{\partial \hat{x}_3}{\partial x} + \dot{J}_{12} \frac{\partial \hat{x}_4}{\partial x} + J_{11} \frac{\partial \hat{x}_5}{\partial x} + J_{12} \frac{\partial \hat{x}_6}{\partial x} \right] [x - \hat{x}]
\end{aligned} \tag{29}$$

while the fourth measurement equation for  $y_4$  is linearized as follows:

$$\begin{aligned}
y_4 &= y_4(\hat{x}) + \left. \frac{\partial y_4}{\partial x} \right|_{x=\hat{x}} (x - \hat{x}) \\
&= \dot{J}_{21}(\hat{x})\hat{x}_3 + \dot{J}_{22}(\hat{x})\hat{x}_4 + J_{21}(\hat{x})\hat{x}_5 + J_{22}(\hat{x})\hat{x}_6 + w_4 \\
&+ \left[ \frac{\partial(\dot{J}_{21})}{\partial \bar{x}} \hat{x}_3 + \frac{\partial(\dot{J}_{22})}{\partial \bar{x}} \hat{x}_4 + \frac{\partial(J_{21})}{\partial \bar{x}} \hat{x}_5 + \frac{\partial(J_{22})}{\partial \bar{x}} \hat{x}_6 \right] [\bar{x} - \hat{x}] \\
&+ \left[ \dot{J}_{21} \frac{\partial \hat{x}_3}{\partial \bar{x}} + \dot{J}_{22} \frac{\partial \hat{x}_4}{\partial \bar{x}} + J_{21} \frac{\partial \hat{x}_5}{\partial \bar{x}} + J_{22} \frac{\partial \hat{x}_6}{\partial \bar{x}} \right] [\bar{x} - \hat{x}]
\end{aligned} \tag{30}$$

The four output equations can now be represented by the following linear discrete time equation:

$$y = cx(n) + w + e(n) \tag{31}$$

where:

$$c = \begin{bmatrix} 1 & 0 & 0 & 0 & 0 & 0 \\ 0 & 1 & 0 & 0 & 0 & 0 \\ \dot{y}_{31} & \dot{y}_{32} & \dot{y}_{33} & \dot{y}_{34} & \dot{y}_{35} & \dot{y}_{36} \\ \dot{y}_{41} & \dot{y}_{42} & \dot{y}_{43} & \dot{y}_{44} & \dot{y}_{45} & \dot{y}_{46} \end{bmatrix}$$

$$e = \begin{bmatrix} 1 & 0 & 0 & 0 & 0 & 0 \\ 0 & 1 & 0 & 0 & 0 & 0 \\ -\dot{y}_{31} & -\dot{y}_{32} & \dot{J}_{11} - \dot{y}_{33} & \dot{J}_{12} - \dot{y}_{34} & J_{11} - \dot{y}_{35} & J_{12} - \dot{y}_{36} \\ -\dot{y}_{41} & -\dot{y}_{42} & \dot{J}_{21} - \dot{y}_{43} & \dot{J}_{22} - \dot{y}_{44} & J_{21} - \dot{y}_{45} & J_{22} - \dot{y}_{46} \end{bmatrix}$$

where the  $\dot{y}$  terms are given in [6,7].

## 5.2 Extended Kalman Filter algorithm

The Extended Kalman Filter (EKF) algorithm uses the following steps [12]:

Kalman Gain matrix:

$$K(n) = P(n)^- c^T(n) [c(n)P(n)^- c^T(n) + w_d]^{-1} \quad (32)$$

- State estimate update:

$$\hat{x}(n)^+ = \hat{x}(n)^- + K(n)(y(n) - c(n)x(n)^- - e(n)) \quad (33)$$

State estimate extrapolation:

$$\hat{x}(n+1)^- = a(n)\hat{x}(n)^+ + b(n)u \quad (34)$$

Error covariance update:

$$P(n)^+ = (I - K(n)c(n))P(n)^- \quad (35)$$

Error covariance extrapolation:

$$P(n+1)^- = a(n)P(n)^+ a(n)^T + V_d \quad (36)$$

The noises  $w_d$  and  $V_d$  are assumed Gaussian white noises, time invariant with zero mean. The initial values were chosen as follows:

$$w_d = \begin{bmatrix} 10^{-12} & 0 & 0 & 0 \\ 0 & 10^{-12} & 0 & 0 \\ 0 & 0 & .08 & 0 \\ 0 & 0 & 0 & 0.8 \end{bmatrix} \quad (37)$$

$$v_d = \begin{bmatrix} 0 \\ 0 \\ 0 \\ 0 \\ 5 * 10^{-5} \\ 5 * 10^{-5} \end{bmatrix} \quad (38)$$

## 6. Experimental Set-Up

The experimental the setup used for this paper consists of a two degree-of-freedom planar robot arm, where each rigid link is driven by a direct drive motor (Figure 5). All motors are connected to the dSPACE(digital Signal Processing and Control Engineering) system, which executes the control program for robot motion [16]. The TRACE software is used to trace any variable of the program in real time and runs on a personal computer , connected to dSPACE by bus expansion.

dSPACE boards are:

DS 1002, Floating point DSP board with TMS320C30,

DS 3001, Incremental Encoder board,

DS 2101, Digital to Analog Conversion board,

DS 2002, Analog to Digital Conversion board.

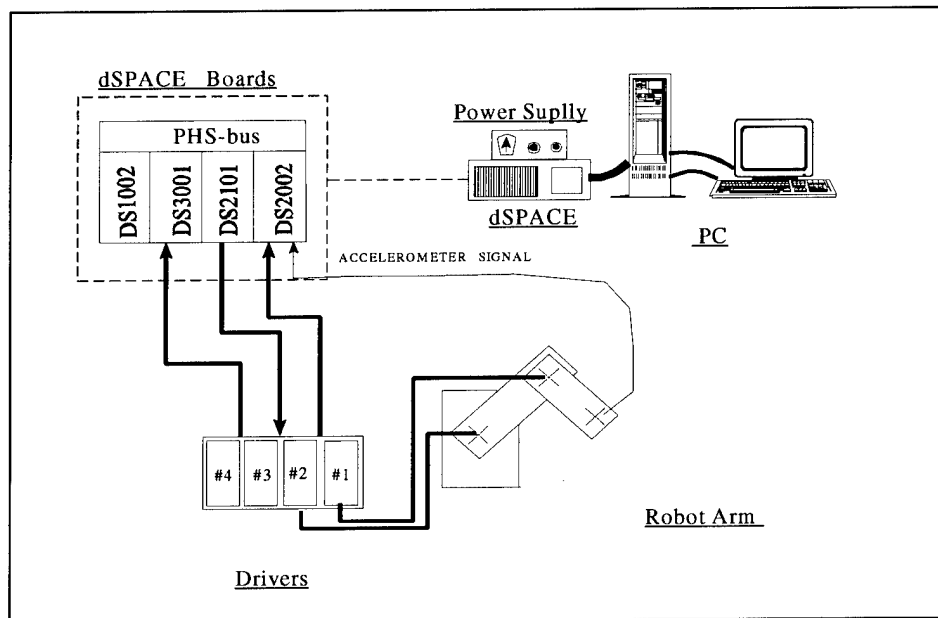

Figure 5. Experimental set-up

## 7. Experimental Results

### 7.1 Joint acceleration estimation

Joint accelerations for each joint of the robot are obtained for different cases. Figure 6 presents the following results: curve (A) represents the results of double numerical derivation (using equation (16)) of the joint position measurements, curve (B) represents joint acceleration obtained using a kinematic equation (17) based on Cartesian acceleration measurements and the derivative of joint position measurement, and curve (C) shows the result of the fusion of case (A) and (B) using the EKF algorithm.

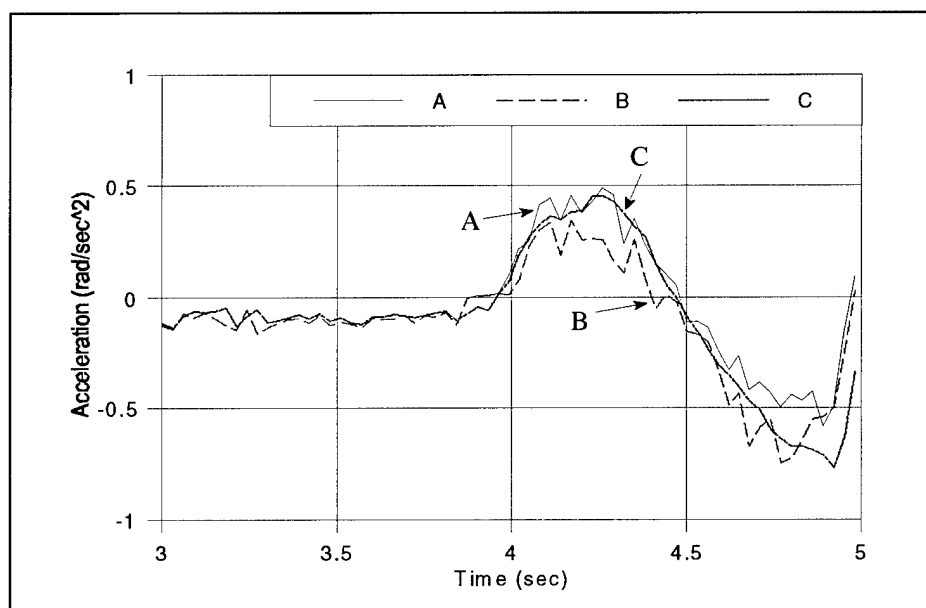

Figure 6. Experimental and estimation results for joint acceleration, double numerical derivative of joint position measurement using equation (16), joint acceleration calculation using equation (17) and accelerometer signals, fusion of (A) and (B) results using EKF.

### 7.2 Impedance control of single arm using acceleration estimation

The significance of the difference between these results is based on generating point-to-point robot motion. In the case of perfect impedance control, the path generated for the endpoint of the robot would be a straight line. The efficiency of the proposed

improvements for the impedance control can, consequently, be evaluated based on comparing actual generated path to ideal straight line path.

Figure 7 shows the resulting end-effector trajectories for a two degree-of-freedom planar robot from the initial position(I) to the desired position(D). This robot has been tested for different cases. In case (a), all the dynamic terms have been compensated by analytical computation. Case(b) is the same as (a) except for the addition a joint observer for compensating unmodelled dynamic terms, using estimated joint accelerations from endpoint accelerometer outputs. In case (c), PD (Proportional Derivative) operational space control was used without any compensation of Coriolis, centrifugal or friction terms; in this case, as shown, the robot arm could not reach the target. Better performance can be obtained by tuning the PD gains, but the performance is dependent on chosen I and D points. In case (d), only joint observers are used ( with no analytical computation for the compensation of Coriolis, centrifugal or friction terms); end point accelerometers outputs are used again to calculate joint accelerations.

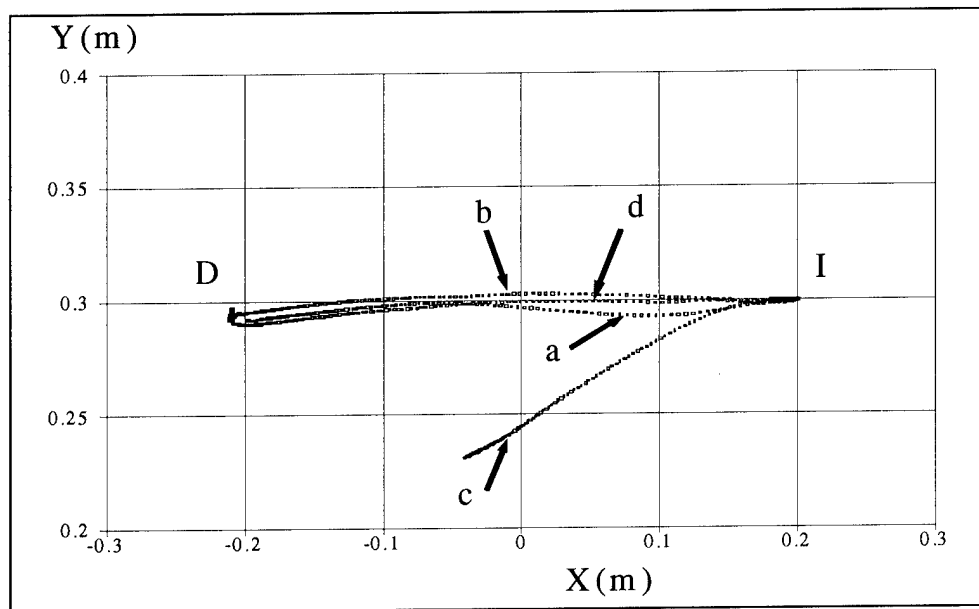

Figure 7. Experimental results for end-effector trajectories for: (a) analytical computation of all dynamic terms, (b) joint observer plus analytical computation of all dynamic terms, (c) PD operation of space control, (d) same as (b) without analytical computation

Cases (a), (b) and (d) show trajectories that are all deflected from the ideal straight line as a result of various forms of partial compensation of the dynamic terms. The conclusion is that all dynamic terms play a significant role and consequently all terms have to be compensated to obtain a trajectory as close as possible to the ideal straight line. Further improvements are obtained in impedance control by the use of an EKF for sensor fusion.

### 7.3 Experimental results of robot arm impedance control using an Extended Kalman Filter based on sensor fusion

Figure 8 shows the results when the dynamic terms are compensated by approximate models and an observer. Curve (a) is the trajectory of the end-effector using acceleration obtained as the second derivative of the joint position. Curve (b) is the trajectory based on estimated acceleration using an EKF and an approximation to a dynamic compensator. The results show that the trajectory that is generated by case (b) is closer to a straight line than that of case (a). These results suggest that an EKF-based approach will significantly improve the performance of robot motion control.

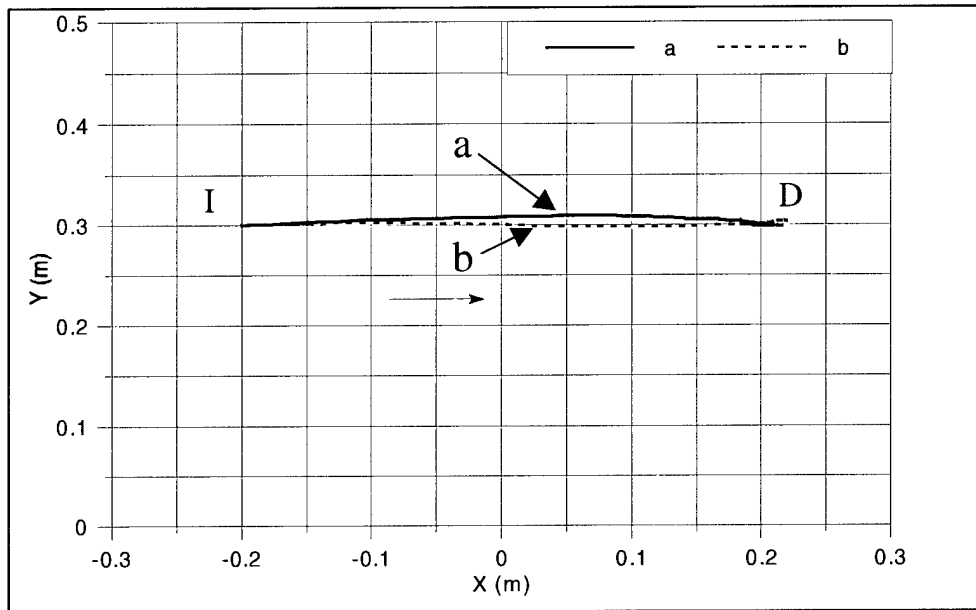

Figure 8. End-effector trajectory of robot arm based on two methods: (a) second derivative of joint positions and (b) EKF in parallel with approximate compensation models of dynamic terms

## 8. Conclusions and Recommendations

---

Non-inertial terms in the computed torque approach used in Impedance control can be estimated indirectly using an acceleration perturbation observer. Improved acceleration estimates can be obtained by fusing signals from joint position and link acceleration sensors. The experimental results prove that the perturbation observer based on sensor fusion can improve the performance of an impedance controller for the trajectory generation of a robot arm and that an almost straight line trajectory is generated. These results indicate that for obtaining a more accurate acceleration signal, the Extended Kalman Filter algorithm is an efficient sensor fusion method. The controller is able to compensate dynamic terms, including centrifugal, Coriolis, and friction terms.

## 9. References

---

1. Ohinishi K., Shibata M., Murakami T., "Motion Control for Advanced Mechatronics", IEEE/ASME Trans. on Mechatronics, Vol. 1., No. 1, March 1996, pp.56-67.
2. Hsia T.C.S., Lasky T.A., Guo Z., "Robot Independent Joint Controller Design for Industrial Robot", IEEE Trans. on Industrial Electronics, Vol. 38, No. 1, Feb. 1991, pp. 21-25.
3. Yousef-Toumi K., Fuhlbrigge T.A., "Application of a Decentralized Time Delay Controller to Robot Manipulators", IEEE, Int. Conf. on Robotics and Automation, 1988, pp.1786-1791.
4. Lu W.S., Meng Q.H., "Impedance Control with Adaptation for Robotic Manipulations", IEEE Transaction on Robotics and Automation, Vol.7, No.3, June,1991, pp. 408-415.
5. Liu G.J., Goldenberg A.A., "Robust Hybrid Impedance Control of Robot Manipulators", IEEE Int. Conf. on Robotics and Automation, April,1991, pp. 287-292.
6. Neculescu D.S., Jassemi-Zargani R., Kalaycioglu S., "Dual Arm Operational Space Control Using Efficient Impedance Modulation", 8th CASI Conference, Nov. 1994, Ottawa, pp. 483-491.
7. Jassemi-Zargani R., Neculescu D.S., "Improved Perturbation Observer for Robot Impedance Control using Extended Kalman Filter Based Sensor Fusion", Proc. CSME Forum, Toronto, 1998, pp. 284-290.
8. Zheng, Y.F., "Integration of Multiple Sensors into a Robotic System and Its Performance Evaluation", IEEE Trans., Robotics and Automation, Oct. 1989, pp. 658-669.
9. Hager, G.D., Engelson, S., Atiya, S., "On Comparing Statistical and Set-Based Methods in Sensor Data Fusion", Proc. IEEE Int., Robotics and Automation, 1993, pp. 352-358.
10. Durrant-Whyte, H., "Integration, Coordination and Control of Multi-Sensor Systems", Kluwer, Boston, 1988.
11. Hager, G.D., "Task-Directed Sensor Fusion and Planning", Kluwer, 1990.  
Goodwin G.C., Sin K.S., "Adaptive Filtering Prediction and Control", Prentice-Hall Inc., 1984.
13. J.A. Barrie, "Modern Control Systems", Prentice-Hall International(UK) Ltd., 1986.
14. G. Ferretti et al. ,Modular Dynamic Virtual Reality Modeling of Robotic Systems, IEEE Robotics and Automation Magazine, Dec. 1999, pp. 13-23.
15. B. Friedland, Control system Design, McGrawHill, 1986.
16. dSPACE, Solutions for Control, Catalog 2000, www.dspaceinc.com

## List of symbols/abbreviations/acronyms/initialisms

---

|                                |   |
|--------------------------------|---|
| DND                            | Department of National Defence (Canada)                         |
| DREO                           | Defence Research Establishment Ottawa                           |
| TR                             | Technical Report  |
| EKF                            | Extended Kalman Filter  |
| DSPACE                         | digital Signal Processing and Control Engineering               |
| $\theta$                       | the vector of angular joint positions                           |
| $\dot{\theta}$                 | the vector of angular joint velocities                          |
| $M_x(\theta)$                  | inertia matrix in Cartesian space                               |
| $M(\theta)$                    | inertia matrix in joint space                                   |
| $V_x(\theta, \dot{\theta})$    | the vector of centrifugal and Coriolis terms in Cartesian space |
| $V(\theta, \dot{\theta})$      | the vector of centrifugal and Coriolis terms in joint space     |
| $G_x(\theta)$                  | the vector gravity term in Cartesian Space                      |
| $G(\theta)$                    | the vector gravity term in joint space                          |
| $F_x(\theta, \dot{\theta})$    | the vector friction term in Cartesian space                     |
| $\tau_n(\theta, \dot{\theta})$ | the vector of friction term in joint space                      |
| $f_{\text{ext}}$               | external force  |
| J                              | Jacobian matrix   |
| $\tau$                         | Torque  |
| $V_1$ & $V_2$                  | White noise in EKF  |

## UNCLASSIFIED

SECURITY CLASSIFICATION OF FORM  
(highest classification of Title, Abstract, Keywords)

## DOCUMENT CONTROL DATA

(Security classification of title, body of abstract and indexing annotation must be entered when the overall document is classified)

|   |   |   |  |
|---|---|---|--|
| 1. ORIGINATOR (the name and address of the organization preparing the document. Organizations for whom the document was prepared, e.g. Establishment sponsoring a contractor's report, or tasking agency, are entered in section 8.)<br>Defence Research Establishment Ottawa<br>3701 Carling Ave<br>Ottawa Ontario K1A 0Z4   |   | 2. SECURITY CLASSIFICATION (overall security classification of the document, including special warning terms if applicable)<br><br>UNCLASSIFIED |  |
| 3. TITLE (the complete document title as indicated on the title page. Its classification should be indicated by the appropriate abbreviation (S,C or U) in parentheses after the title.)<br><br>Extended Kalman Filter Sensor Fusion Signals of Nonlinear Dynamic Systems (U)   |   |   |  |
| 4. AUTHORS (Last name, first name, middle initial)<br><br>Jassemi-Zargani, Rahim; Necsulescu, D.S.  |   |   |  |
| 5. DATE OF PUBLICATION (month and year of publication of document)<br><br>December 2001   | 6a. NO. OF PAGES (total containing information. Include Annexes, Appendices, etc.)<br><br>30                                | 6b. NO. OF REFS (total cited in document)<br><br>16   |  |
| 7. DESCRIPTIVE NOTES (the category of the document, e.g. technical report, technical note or memorandum. If appropriate, enter the type of report, e.g. interim, progress, summary, annual or final. Give the inclusive dates when a specific reporting period is covered.)<br><br>DREO Technical Report  |   |   |  |
| 8. SPONSORING ACTIVITY (the name of the department project office or laboratory sponsoring the research and development. Include the address.)<br>Space System Technology Section, DREO<br>DREO\SST<br>3701 Carling Ave. Ottawa Ontario K1A 0Z4   |   |   |  |
| 9a. PROJECT OR GRANT NO. (if appropriate, the applicable research and development project or grant number under which the document was written. Please specify whether project or grant)<br><br>5ea12   | 9b. CONTRACT NO. (if appropriate, the applicable number under which the document was written)                               |   |  |
| 10a. ORIGINATOR'S DOCUMENT NUMBER (the official document number by which the document is identified by the originating activity. This number must be unique to this document.)<br><br>DREO TR 2001-155  | 10b. OTHER DOCUMENT NOS. (Any other numbers which may be assigned this document either by the originator or by the sponsor) |   |  |
| 11. DOCUMENT AVAILABILITY (any limitations on further dissemination of the document, other than those imposed by security classification)<br><br><input checked="" type="checkbox"/> Unlimited distribution<br><input type="checkbox"/> Distribution limited to defence departments and defence contractors; further distribution only as approved<br><input type="checkbox"/> Distribution limited to defence departments and Canadian defence contractors; further distribution only as approved<br><input type="checkbox"/> Distribution limited to government departments and agencies; further distribution only as approved<br><input type="checkbox"/> Distribution limited to defence departments; further distribution only as approved<br><input type="checkbox"/> Other (please specify): United States & United Kingdom Defence Departments and Defence contractors |   |   |  |
| 12. DOCUMENT ANNOUNCEMENT (any limitation to the bibliographic announcement of this document. This will normally correspond to the Document Availability (11). However, where further distribution (beyond the audience specified in 11) is possible, a wider announcement audience may be selected.)<br><br>Unlimited Announcement & Distrimution  |   |   |  |

UNCLASSIFIED

SECURITY CLASSIFICATION OF FORM

DCD03 2/06/87

13. ABSTRACT (a brief and factual summary of the document. It may also appear elsewhere in the body of the document itself. It is highly desirable that the abstract of classified documents be unclassified. Each paragraph of the abstract shall begin with an indication of the security classification of the information in the paragraph (unless the document itself is unclassified) represented as (S), (C), or (U). It is not necessary to include here abstracts in both official languages unless the text is bilingual).

World modeling for achieving operational space motion control of robot arms requires accurate measurements of positions and velocities in both joint and operational space. Servomotors used for joint actuation are normally equipped with position sensors and, optionally, with velocity sensors for interlink motion measurements. Further improvements in measurement accuracy can be obtained by equipping the robot arm with accelerometers for absolute acceleration measurement. In this report an Extended Kalman Filter is used for multi-sensor fusion. The real-time control algorithm was previously based on the assumption of a jerk represented as a white noise process with zero mean. In reality, the accelerations are varying in time during the arm motion and the zero mean assumption is not valid, particularly during periods of fast acceleration. In this report, a model predictive control approach is used for predetermining next-time-step jerk such that the remaining term can be modeled as Gaussian white noise. Experimental results illustrate the effectiveness of the proposed sensor fusion approach..

14. KEYWORDS, DESCRIPTORS or IDENTIFIERS (technically meaningful terms or short phrases that characterize a document and could be helpful in cataloguing the document. They should be selected so that no security classification is required. Identifiers such as equipment model designation, trade name, military project code name, geographic location may also be included. If possible keywords should be selected from a published thesaurus. e.g. Thesaurus of Engineering and Scientific Terms (TEST) and that thesaurus-identified. If it is not possible to select indexing terms which are Unclassified, the classification of each should be indicated as with the title.)

Sensor fusion, Extended Kalman Filter, Control systems, Robotics