

REPORT DOCUMENTATION PAGE

Form Approved
OMB No. 0704-0188

Public reporting burden for this collection of information is estimated to average 1 hour per response, including the time for reviewing instructions, searching data sources, gathering and maintaining the data needed, and completing and reviewing the collection of information. Send comments regarding this burden estimate or any other aspect of this collection of information, including suggestions for reducing this burden to Washington Headquarters Service, Directorate for Information Operations and Reports, 1215 Jefferson Davis Highway, Suite 1204, Arlington, VA 22202-4302, and to the Office of Management and Budget, Paperwork Reduction Project (0704-0188) Washington, DC 20503.

PLEASE DO NOT RETURN YOUR FORM TO THE ABOVE ADDRESS.

1. REPORT DATE (DD-MM-YYYY) 07/23/2002		2. REPORT DATE Annual Report		3. DATES COVERED (From - To) 04/01/2001 - 06/30/02	
4. TITLE AND SUBTITLE First Annual Report (AR1)				5a. CONTRACT NUMBER	
				5b. GRANT NUMBER N00014-01-1-0634	
				5c. PROGRAM ELEMENT NUMBER	
6. AUTHOR(S) Juan Carlos Balda, Fred D. Barlow, Kraig J. Olejniczak				5d. PROJECT NUMBER 01PR07524-00	
				5e. TASK NUMBER	
				5f. WORK UNIT NUMBER	
7. PERFORMING ORGANIZATION NAME(S) AND ADDRESS(ES) University of Arkansas Office of Contracts and Grants Fayetteville, AR 72701				8. PERFORMING ORGANIZATION REPORT NUMBER	
9. SPONSORING/MONITORING AGENCY NAME(S) AND ADDRESS(ES) Mr. Terry Ericson Office of Naval Research Ballston Centre Tower One 800 North Quincy Street, Arlington VA 22217-5660				10. SPONSOR/MONITOR'S ACRONYM(S) ONR	
				11. SPONSORING/MONITORING AGENCY REPORT NUMBER	
12. DISTRIBUTION AVAILABILITY STATEMENT Approved for Public Release, distribution unlimited.					
13. SUPPLEMENTARY NOTES					
20020729 120					
14. ABSTRACT The first Annual Report summarizes the activities performed on this grant from May 1, 2001, through June 30, 2002. One graduate student has been working on the overall direct cooling system design and packaging philosophy of our high-voltage, spray-cooled power module. Two other graduate students have investigated solution strategies for connecting IGBTs in series which are amenable to miniaturization and integration for our direct cooling packaging strategy. Finally, another graduate student has been working on novel SiC transistors for use in high-temperature power electronics packaging.					
15. SUBJECT TERMS direct cooling, power modules, series-connection IGBT, SiC transistors					
16. SECURITY CLASSIFICATION OF:			17. LIMITATION OF ABSTRACT UU	18. NUMBER OF PAGES 16	19a. NAME OF RESPONSIBLE PERSON Juan Carlos Balda
a. REPORT UU	b. ABSTRACT UU	c. THIS PAGE UU			19b. TELEPHONE NUMBER (Include area code) 479-575-6578

**DIRECT COOLING OF PROPULSION DRIVES
FOR HIGH POWER DENSITY AND LOW VOLUME**

Award No. N00014-01-1-0634

Period of Performance: May 01, 2001 – June 30, 2002

First Annual Report (AR1)

Juan Carlos Balda, Fred D. Barlow, Kraig J. Olejniczak and Aicha Elshabini

University of Arkansas
Department of Electrical Engineering
3217 Bell Engineering Center
Fayetteville, AR 72701-1201
(501) 575-3005

Prepared for

Office of Naval Research
Ballston Center Tower One
800 North Quincy Street
Arlington, VA 222A-5660

July 2002

Introduction

This First Annual Report summarizes the activities performed on this grant from May 1, 2001, through June 30, 2002.

The research team consists of Drs. J. C. Balda, F. D. Barlow, K. J. Olejniczak and A. Elshabini, and graduate students Habib Mustain (doctoral candidate), Alex Lostetter (doctoral candidate), Sri Ram Kumar Maddula, and Devender Singh (MS candidates). Mr. Mustain is working on the overall direct cooling system design and packaging philosophy of our high-voltage, spray-cooled power module. Mr. Kumar and Mr. Singh are using PSpice® to investigate solution strategies for connecting IGBTs in series which are amenable to miniaturization and integration for our direct cooling packaging strategy. Finally, Mr. Lostetter has been working on novel SiC transistors for use in high-temperature power electronics package.

Main Activities from May 1, 2001, to June 30, 2002

The following technical activities have been performed during this time period:

- Literature survey and understanding of direct cooling methods for power semiconductors;
- Thermal simulation of spray-cooled power modules;
- Design of a spray-cool test bed for power modules;
- Literature survey and analysis of different methodologies for the series connection of IGBTs; and
- PSpice simulation of series-connected IGBTs.

Spray Cooling

A key problem with power modules today is the very high power densities that result in significant problems with thermal management. Traditionally, high thermal conductivity materials have been used to overcome this problem by reducing the thermal resistance between the heat source(s) and the heat sink or cooling system. However, this methodology has some fundamental limitations due to the thermal conductivity of materials as well as the interfaces that inevitably exist within a module. An alternative approach is the use of a direct cooling method to extract the waste heat (i.e., power losses) from the electronic components. Several approaches have been explored; however, the most effective technique is spray cooling. Spray cooling offers superior performance since it is based on a phase change process that conducts heat away from surfaces with a far greater efficiency than simple conduction or convection technique. A key element of this work is to explore the implementation of spray cooling for high-power systems. This task includes the optimization of a spray-cooling system for power electronic modules as well as the development of a packaging methodology for the electronic components within the module.

Thermal Modeling

In order to determine the optimum methodology for spray cooling, the ability to model the thermal performance is the key. As a result, the researchers have developed a preliminary model for a spray-cooled power module, based on a typical six pack IGBT module commonly used for motor drives. The module consists of six (6) IGBTs and six (6) freewheeling diodes mounted on a Direct Bond Copper (DBC) substrate. This model, illustrated in Figure 1, has been explored with conventional convective cooling as well as with spray cooling. Figure 1 illustrates the typical behavior observed for this configuration using a finned heat sink under forced convection conditions.

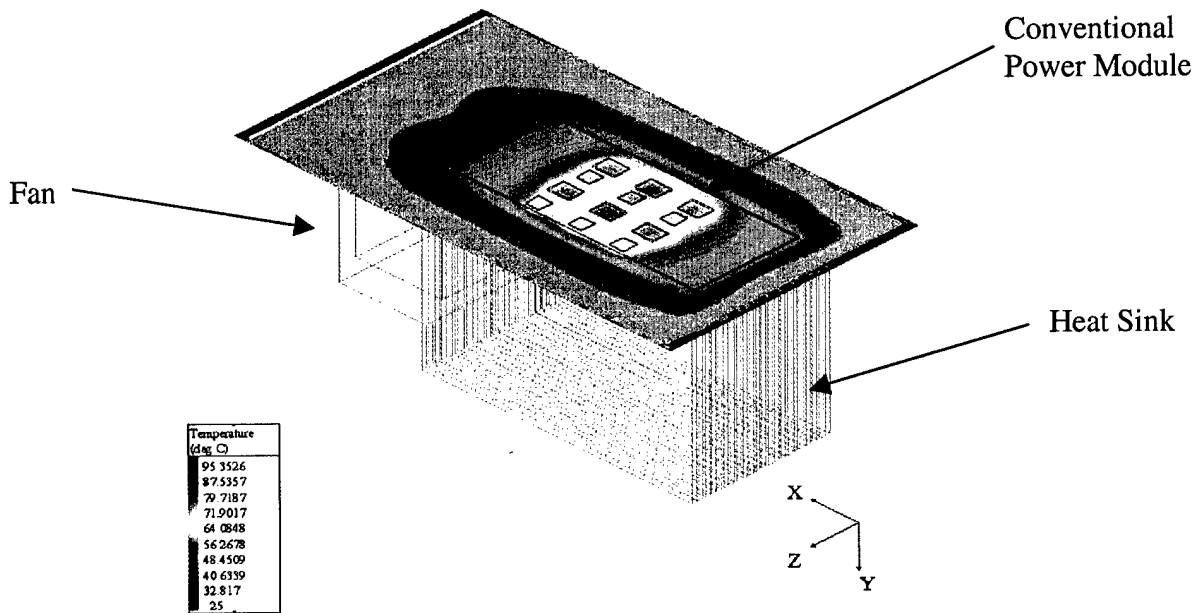

Fig. 1. Thermal model of a typical three-phase inverter power module. (This figure assumes forced convection cooling.)

Figure 2 summarizes the behavior of this module as a function of power loss in the active devices. In comparison, identical modules have been modeled using spray cooling. This work has been done for a range of heat transfer coefficients. It is possible to achieve heat transfer coefficients as high as 30,000 using this technique. Figure 3 illustrates the performance of a power module (identical to the module in Figure 1) with 500 W of thermal loss for a range of heat transfer coefficients (h). (At 500 W, the junction temperature is approximately 95°C. Thus, the "breakeven" h value is approximately 10,000.) For an h value greater than ~15,000, the performance of the spray-cooled system is far superior to the conventional cooling case. In some cases, junction temperatures may be as much as 50% lower for the spray cooling case. In fact, this has direct and positive implications to power semiconductor device and system reliability.

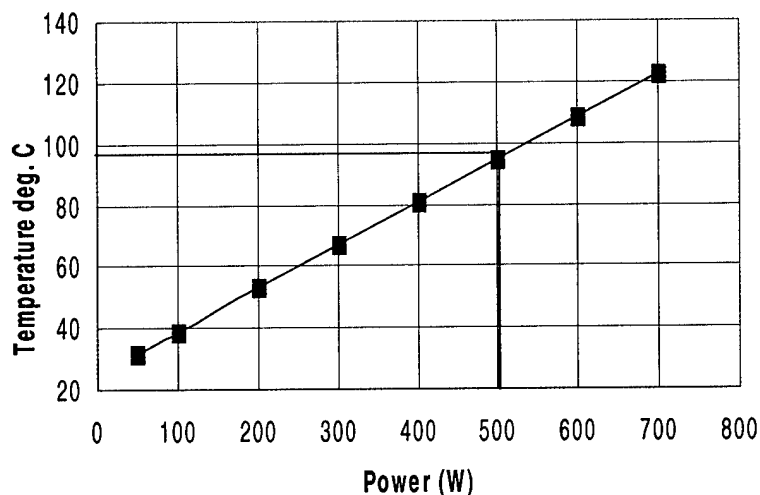

Fig. 2. Thermal simulation results for a forced convection three-phase inverter module. The data are based on junction temperatures as a function of the thermal loss in the module.

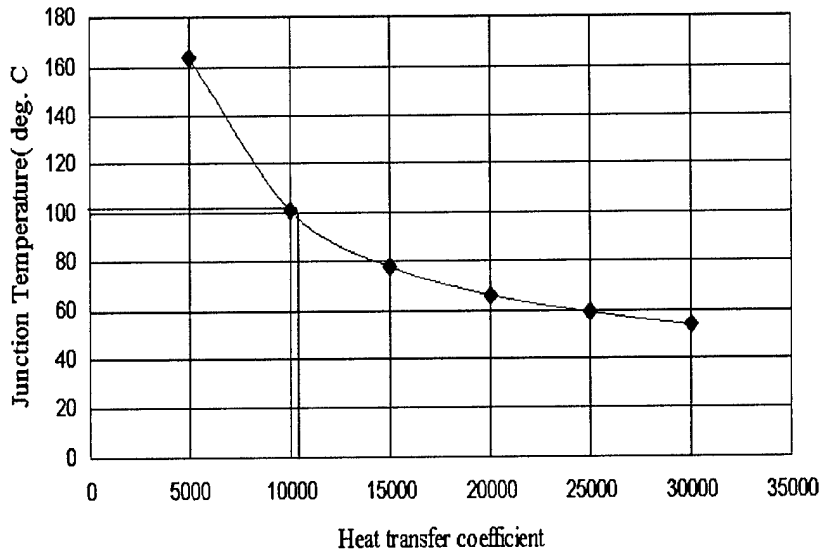

Fig. 3. Simulation results for a spray-cooled module operating with 500 W of power loss for a variety of h values.

These modeling results illustrate the potential of spray cooling to solve some of the thermal management problems that currently exist in high-power electronic systems.

Spray Cooling Test Bed Development

In order to verify these results, the researchers are currently fabricating a spray cooling test bed. This test bed will consist of a spray-cool system that has been modified for high-power modules, departing from an existing system at the University of Arkansas that was originally used to cool VME cards for testing high-density computer modules, Figure 4.

This system will be modified to provide high-power input and output terminals and to replace the standard VME card with a metal card designed to provide universal support for virtually any power module of interest, as seen in Figure 5.

Bus bars have been included to provide the high current / high voltage I/O. In addition, a D sub connector is provided for temperature sensor I/O and has been designed to monitor the junction temperatures of the devices within a given power module. A custom spray head has been designed that is suitable for cooling a full (H) bridge power module.

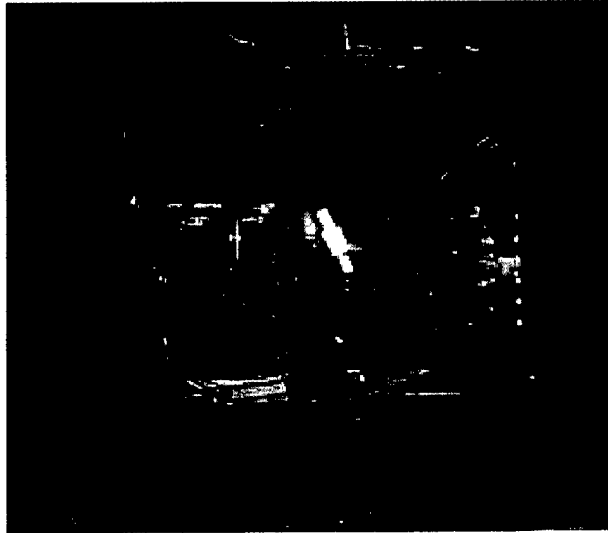

Fig. 4. Existing spray cooling system at the University of Arkansas. This system cools modules on a VME card.

The initial application for this test bed will be a thermal test module designed by the researchers. This module, illustrated in Figure 5, consists of an IMS substrate and eight (8) thermal test die. The test dice are designed to mimic the thermal behavior of four (4) IGBTs and four (4) diodes commonly used in power electronic systems. Each test die contains an on-board heater that is used to simulate the waste heat or power loss generated in each power device, as well as temperature sensors that monitor the junction temperature of each device. A dielectric fluid from the spray nozzle is directly sprayed onto the devices. The fluid vaporizes to remove heat from the device; the heat is then removed from the system with a heat exchanger. The vapor condenses and fluid collects in the reservoir and is pumped back onto device in a continuous cycle. Ramping the power loss in the devices and monitoring the junction temperatures, the researchers will be able to verify their thermal models. In addition, this test module will allow for the computation of heat transfer coefficients for a variety of spray nozzle/spray head configurations. In the future, a number of studies will be investigated to understand the fundamental aspects of high heat flux spray cooling. First, the placement of spray nozzle is fairly critical to assure adequate cooling, and secondly, the spray velocity is probably the most important spray parameter. The heat transfer coefficient always increases with an increase in spray velocity.

The immediate goal of this portion of the work is to demonstrate the spray cooling technique is the most efficient alternative for the removal of high heat fluxes. Using this technique, the researchers will develop a series of power modules and evaluate their relative performance in comparison to conventional cooling and packaging methodologies.

Series Connection of IGBTs

The series operation of IGBTs allows for higher dc-bus voltages leading to reduced currents for a given power (i.e., kVA) rating. In turn, this results in a number of physical or mechanical advantages: smaller cross-section (and thus lighter) conductors, smaller and lighter connection and monitoring hardware (e.g., current and potential transformers), and physically smaller over-current protection devices leading toward optimal system size to space ratios. Electrically, a number of advantages arise. Including reduction of stray inductance and capacitance effects, thus transforming degrading first-order effects into second-order effects. Furthermore, operation at high voltages can eliminate the need for large footprint, large mass step-down transformers, yielding additional space, mass, and cost advantages.

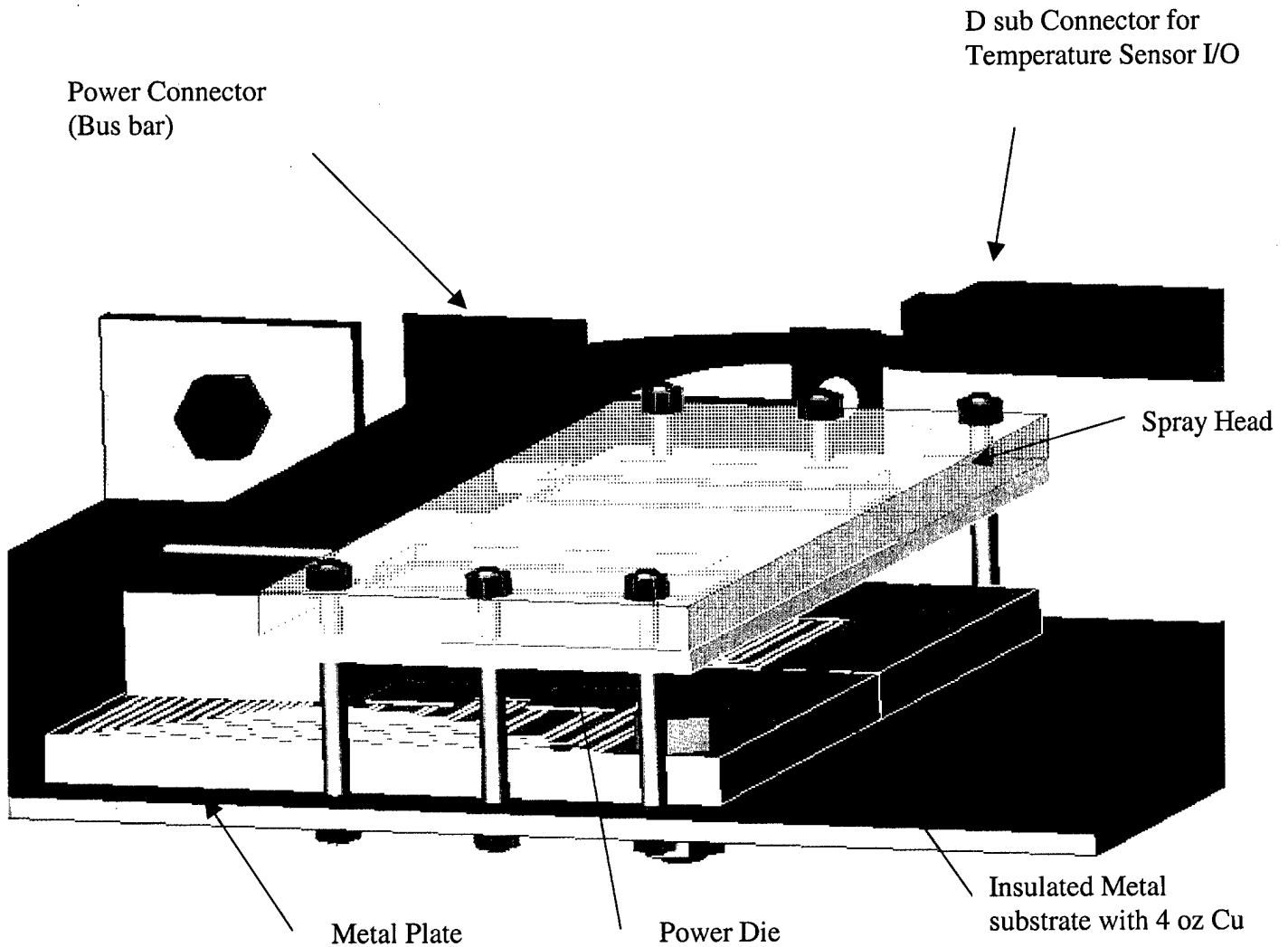

Fig 5. A 3D rendering of the proposed thermal test module designed by the researchers. Fabrication of the modified spray system has already begun based on this design.

Unfortunately, there are a few disadvantages. First, switching differences caused by parameter variations within the IGBT or different time delays in the gate circuitry may lead to operating points outside the IGBT's safe operating area (SOA). This leads to the application of a voltage and/or current that can lead to the IGBT's destruction. Hence, "reasonable" voltage sharing must be ensured under transient and steady-state conditions so that the IGBT does not operate outside its SOA. Second, higher dc-bus voltages and higher load currents result in increased dv/dt and di/dt , leading to higher electromagnetic interference and electrical stresses. Therefore, any successful technique for connecting IGBTs in series must address these disadvantages.

Additionally, another consideration is that the switching signals have to be level shifted across a high-voltage barrier that is capable of changing rapidly. This problem is widely known and has been solved for the typical two-level inverter.

For example, a two-level inverter with six (6) IGBTs in series per phase (that is, three (3) IGBTs to realize the top device and three (3) for the bottom device) will require six (6) different power supplies for each phase, or 16 different power supplies for the whole inverter. The level shifter must have very low stray capacitance to earth due to the encountered high dv/dt , which can cause electromagnetic interference and false IGBT triggering.

Various Techniques for Connection in Series of IGBT

Techniques used for the series connection of IGBTs can be classified into those performing voltage balancing on the load (i.e., high voltage, high power) side or the gate (i.e., control) side. Examples of the former are:

- Passive snubbers [1]
- Active snubbers [2]-[4]

Examples of gate-side voltage balancing techniques are:

- Gate current/pulse control [5]-[8]
- Active gate control voltage balancing [6, 9, 10]
- Active clamping on the gate [11]-[13]
- Master/slave gate voltage shaping [14]
- dv/dt and di/dt control [15, 16]
- Analog/digital gating control [17, 18]

The main factors to be considered in the design of a power module having several IGBTs connected in series are the following:

1. High blocking voltages;
2. Low switching and power losses;
3. Voltage balancing during static and dynamic conditions;
4. High efficiency with reduced cost;
5. Simplicity and compactness;
6. Minimum passive component part count;
7. Reduced voltage overshoot;
8. High switching frequencies with reduced switching delays; and
9. Avoid using snubber circuits (since they increase losses).

The main goal of this ONR grant is to study the feasibility of direct cooling methods for power modules used for electric propulsion of electric ships to maximize power density and minimize volume. Therefore, the series-connection of IGBTs in hard-switched converters will be explored due to the above-mentioned advantages. **Traditional** passive snubbers will not be pursued since they do not lend themselves to integration within a power module. From an analysis of the main references in this field, the techniques presented in [6] and [10] will be initially considered further in this research project.

Technique 1 - Series-connected IGBT using simple gate auxiliary circuitry [10]

This technique proposes using a simple gate auxiliary circuit requiring two resistors, two capacitors and one diode. Figure 6 illustrates the proposed circuitry. The proposed scheme does not degrade the switching frequency of the system and the switching losses are comparable with those without it since all auxiliary components have very small ratings when compared to the IGBT rating. Resistors R1 and R2 achieve static voltage balancing while capacitors C_1 and C_2 accomplish dynamic voltage balancing. The function of the fast diode D in the gate circuitry is to minimize the IGBT overvoltage at turn off.

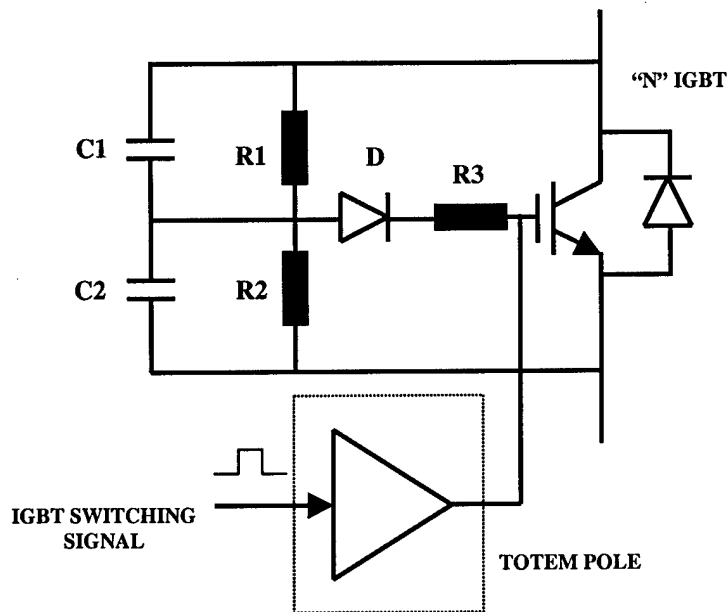

Fig. 6 Voltage balancing circuitry.

The main advantage of this technique is its simplicity. However, its implementation in a power module will be investigated during the second year of this ONR grant.

Technique 2 – Active gate-controlled voltage balancing of series connected IGBT [6]

This digitally-based voltage balancing technique is divided into the following parts:

- (a) *Transient voltage balancing at turn-on and turn-off conditions:* Figure 7 illustrates the block diagram where the T_{dON} and T_{dOFF} time delays are controlled using a PI controller to compensate for variations due to different IGBT parameters or gate circuitry time delays.
- (b) *Static voltage balancing in the off state:* Figure 8 displays the block diagram of this controller whose goal is to equalize the IGBT collector-emitter voltages so the dc-bus voltage is equally distributed between all IGBT in the off state.
- (c) *dv/dt control at turn off:* Figure 9 depicts the conceptual block diagram. The collector-emitter voltage is sensed, differentiated, and compared with the allowed voltage rate.
- (d) *di/dt control at turn on:* Figure 10 shows the conceptual block diagram. The sensed collector current rise di_c/dt is used to maintain it below the IGBT maximum current rate.

In theory, this technique allows building high-voltage switches using series-connected IGBT without slowing down the switching speed or increasing switch losses. It is expected to verify the feasibility of these concepts in the second year of this ONR grant. For example, the IGBT collector-emitter voltage in the *off state* may greatly depend on the conditions at turn off. Then, the static voltage balancing circuitry may not be necessary depending on the performance of the transient controller.

Another issue is that the di/dt control circuitry at turn-on may be only required when paralleling IGBT. However, this is not the case at this point of this research work since the researchers are only considering series connection of IGBT.

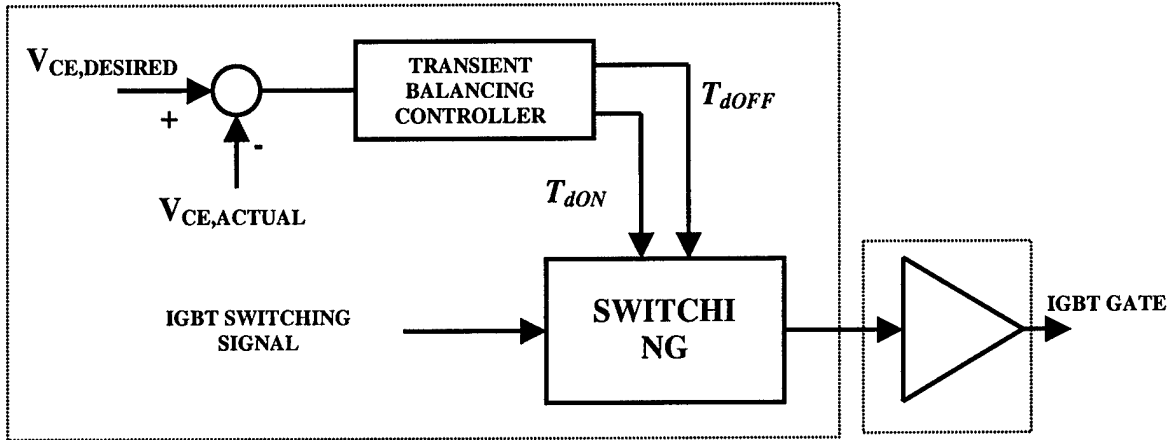

Fig. 7 Transient voltage balancing controller for one IGBT of “*n*” series-connected IGBT.

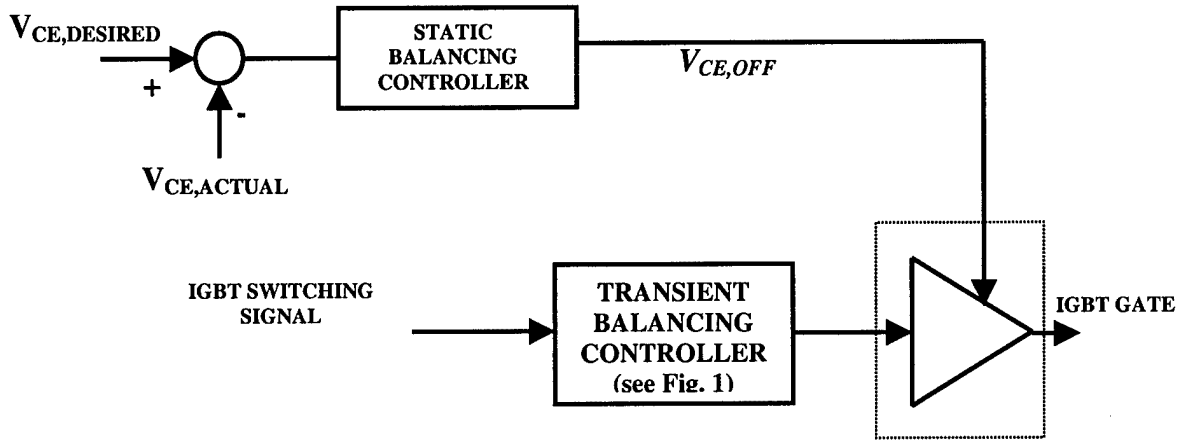

Fig. 8 Static voltage balancing controller for one IGBT of “*n*” series-connected IGBT.

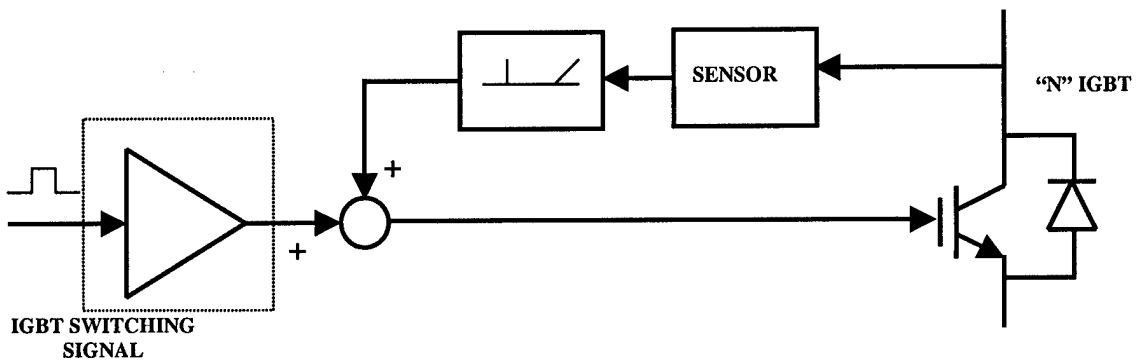

Fig. 9 Block diagram of dv/dt control.

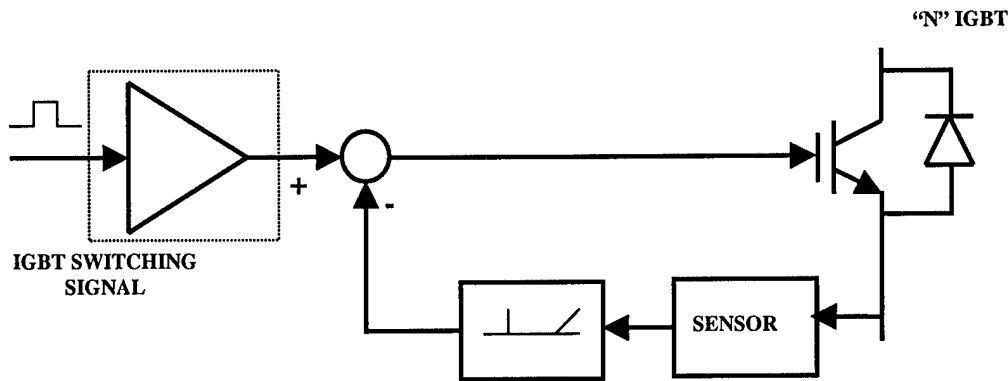

Fig. 10 Block diagram of the di/dt control.

Novel Silicon-Carbide (SiC) Based Semiconductor Transistors for Use in High Temperature Power Electronics Packaging

Here, we discuss our work with the utilization of the world's first commercial grade SiC static induction transistors (SITs) in a high-temperature power electronics package and presents experimental device characterization of key parameters important to power applications. These devices were fabricated for RF switching applications (i.e., in the GHz range), and thus, have never been investigated for power switching. This is our first work in characterizing these devices for power switching, with subsequent work in packaging these devices.

Introduction

As one observes the characteristics of current silicon-based device technology, the limiting factors of such technology are quickly becoming more prevalent and apparent. Clock speeds of microprocessors are increasing, approaching the switching speed limitations of silicon-based devices. Transistors are shrinking in size while their bare die footprints are increasing in size, thus bearing natural device thermal dissipation limits and device junction operating temperature limits (most are aware of the massive heat sinks now incorporated onto Intel processors). If the technology is extended to high-performance applications such as electronics in military vehicles and/or spacecraft, the limitations of silicon become even more apparent. Silicon transistors reach normal operational limits at 125 °C and are easily susceptible to radiation environments, such as nuclear weapons radiation in the case of war, or the sun and cosmic radiation in space applications (although there are a few specially designed silicon devices that work towards these issues).

The past decade has seen a slow but steady increase into the research of the viability of SiC-based device technology. This technology has the potential to solve most, if not all of the limitations currently associated with silicon electronics; specifically, the switching speed limitations and the junction temperature limitations associated with these devices. The University of Arkansas investigators of this ONR grant are currently working in association with Northrop Grumman Corporation and the United States Air Force in order to bring to fruition the world's first military and commercial grade SiC-based transistors. Silicon-carbide based devices have a theoretical operational limit exceeding 600 °C (compared to 125 °C of silicon) and are expected to operate in the 10s to 100s of GHz range. We will discuss our preliminary experimental test results and data of this revolutionary technology.

Background on SiC

The first real interest in the use of SiC as an electronic substrate material dates back to the late 1950's, but it was not until the late 1980's and early 1990's that the research area truly began to gain momentum. This was when Nishino and Powell developed the hetero-epitaxial growth of SiC crystals on Si substrates. The early and mid-1990's found the introduction of commercial-grade SiC wafers of 4H-SiC and 6H-SiC polytypes [19].

The industry, however, is still plagued with unreliable and highly defective wafers, slowing much of the desired research in SiC device development. The two major reasons for crystal growth difficulties are: (1) conventional melt techniques (such as those used in silicon) cannot be utilized since SiC does not melt under reasonably attainable pressures and temperatures (SiC sublimates at temperatures above 1800 °C), and (2) different polytypes with different electrical characteristics can grow under identical conditions [20, 21]. Current SiC wafers contain high defect densities; the most significant of which are tubular voids referred to as *micropipes*, which in turn limit the defect-free semiconductor surface area and thus the size of the devices.

Despite these defects and the difficulty in creating viable SiC-based electronics, research and development into the area has been pushing steadily forward. Throughout the 1990's, a number of research institutions and companies based in the United States and Europe have worked on these devices. Late in the summer of 2001, the world's first commercially available SiC diode was unveiled by the German-based company Infineon at the European Power Electronics Conference in Graz, Austria [22, 23]. The choice of pursuing a high-power Schottky diode had been made in light of SiC's superior electrical and switching performances. In direct comparison to Si Schottky diodes, SiC Schottky's have one-tenth the switching power loss (meaning ten times more efficiency) and the losses are completely independent of operational temperature. However, the electronics packaging technology has not taken advantage of the additional superior characteristic of high temperature operation, and so the devices were released under standard temperature restrictions (125 °C), even though they could theoretically operate up to 600 °C.

Application of SiC Electronics [21]

The two major advantages of SiC devices, which have already been mentioned, are: (1) lower electrical switching losses and increased electrical switching frequencies, and (2) increased operating temperature.

The potential applications of SiC are widespread. Military and space exploration vehicles are the first applications that will greatly benefit from this technology. Silicon electronics are currently so fragile that great pain and expense must be taken to remove them from harsh environments, contain and protect them, cool them, and shield them from excessive shock. Not only are such systems expensive, but they are also complicated, susceptible to reliability issues, and they are extremely heavy. Imagine the control electronics and sensors of a jet or rocket engine placed directly into or onto the engine—or a Venus probe that would not meltdown within 30 seconds of landing on the planet's surface. Other high-performance applications to benefit would be nuclear power reactors, where sensors can endure the high temperature and high radiation environments; or petroleum and geological exploration, where electronics can be sent deep beneath the earth in high temperature wellbores.

The first highly commercial area likely to benefit from SiC will be the automotive electronics industry, where currently the development, protection, and reliability of auto electronics is a high priority. With SiC, electronics would not have to be shielded from the heat of the engine compartment; instead, electronics would be placed directly on or within the engine block in order to guarantee an improved performance. Beyond automobiles, any system that requires cooling or heat sinking can be reduced. Weight and cost of extra materials would be reduced and eliminated, performance and reliability would be improved, and smaller size would become all the more important.

The key to all of these issues is two fold. First, the SiC transistor must become a commercial reality. Second, the high temperature packaging of this technology must be realized in order to gain the full advantages it can offer. Currently, Northrop Grumman Corporation is finishing the development of the world's first commercial grade SiC transistor, under contract to the United States Air Force. The 4-H SiC Static Induction Transistor (SIT) is a normally ON device (as opposed to a FET, which is normally OFF) designed for confidential military applications. The researchers are working with Northrop to verify certain device electrical switching characteristics, to develop high-temperature technology for SIT packaging, and most importantly, to verify full SIT operation in an industry (as opposed to military) viable application. The researchers are charged with the task of building a fully functional SiC SIT based high-temperature, high-power, power-electronics converter for a motor drive application.

SiC SIT Testing

The first step in this task has been to perform electrical characteristic testing of 24 of the SiC SITs. SIT switches (which have also been called V-Channel JFETs) are controlled in a similar fashion to MOSFETs, except that gate switching pulsed bias must be applied between -10 V (OFF) and 0V (ON) instead of a power MOSFET's 0 V (OFF) and 10 V (ON). Figure 11 illustrates the experimental test turn-ON characteristic data for one of the SiC SITs (sweeping voltage and current), illustrating the device switches ON with a gate to source (V_{gs}) voltage of approximately -1 V . At a $V_{gs} = -3\text{ V}$, the device clearly is not conducting and is turned OFF.

In order to utilize SiC SITs in power electronic switching applications, the transistors must operate under high voltage and high current conditions. High voltage tests have been conducted, indicating the transistors will operate in excess of at least 300 V , as illustrated in a captured oscilloscope image, Figure 12. Channel 1 illustrates the voltage applied by the switching circuit, while Channel 2 illustrates the voltage level operating across the SIT. The investigators are currently conducting the high current experimental testing.

High Temperature SiC SIT Based Half-Bridge Inverter

In conjunction with SiC SIT testing, the authors have been performing the required high-temperature circuit design and high-temperature packaging design required to fabricate the fully functional half-bridge inverter. The converter is designed to operate at a temperature of $300\text{ }^{\circ}\text{C}$ and switch at $3,000\text{ W}$, utilizes specialized SOI HTMOS low-voltage control devices obtained through Honeywell Electronics, high-temperature ceramic resistors, Infineon and Cree SiC diodes, Northrop Grumman high-power SiC SIT switches, and high thermal conduction state-of-the-art diamond substrates (upon which to build the electronic circuitry). The overall package dimensions measure approximately $50\text{ mm} \times 50\text{ mm} \times 50\text{ mm}$ —smaller than a deck of cards—and does not require a heat sink for thermal dissipation. The cross-section of the package design strategy is illustrated in Figure 13.

There are a very few specially designed high thermal performance low voltage Si devices built by Honeywell Electronics which can operate up to temperatures of $300\text{ }^{\circ}\text{C}$. This limited suite of devices was utilized by the investigators in the design of the novel control circuitry required to operate the half-bridge SiC SIT circuit.

Since there are no silicon HTMOS high power switching devices (beyond 90 W), the 3 kW inverter utilizing SiC SITs is the first of its kind designed for operation above $150\text{ }^{\circ}\text{C}$. Figure 14 illustrates the complete novel power electronics circuit design developed by the researchers, utilizing the half-bridge switching circuit to drive a 3 kW AC motor. PSpice™ software simulations have been run to verify proper operation of the gate control signals, dead time control, frequency control, and proper drive signals to the motor load.

SIT # 1203 Switch-ON Characteristic Curve

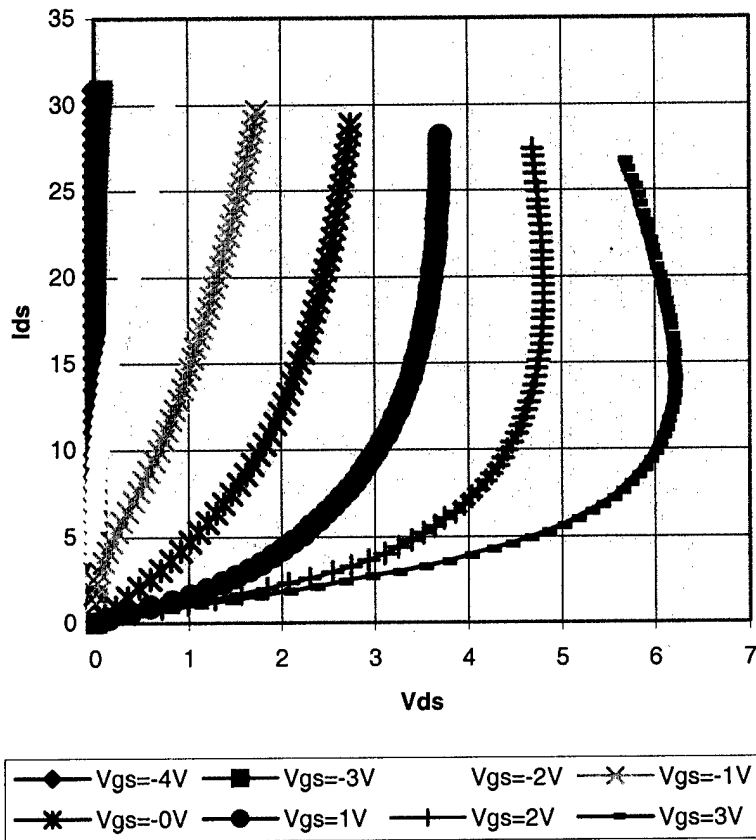

Fig. 11. SiC SIT experimental characteristic data.

A great amount of time, effort, and detail has gone into the development and design of the high temperature power electronics package as well, with specific attention applied to the application of high performance diamond substrates. The investigators have performed detailed thermal, stress, and processing analysis (including Finite-Element software analysis) on the diamond substrate power package referred to by Figure 13, and readers are encouraged to explore these analyses in the investigators' publications [24, 25].

Closing Remarks on SiC Research at UA

This section has introduced the reader to the concept and theoretical advantageous application of SiC over Si based electronics, including superior switching performance, reduced electrical losses, and improved thermal performance. The investigators have stressed; however, that SiC is still in its infancy. The UA researchers are involved in that infancy, working closely with Northrop Grumman Corporation and the United States Air Force to bring about the world's first commercial-grade SiC transistors. The investigators are actively advancing the high-temperature packaging aspects of SiC, and in particular, are currently in the process of fabricating fully functioning proof-of-concept SiC SIT-based, high-temperature power electronic converter prototypes.

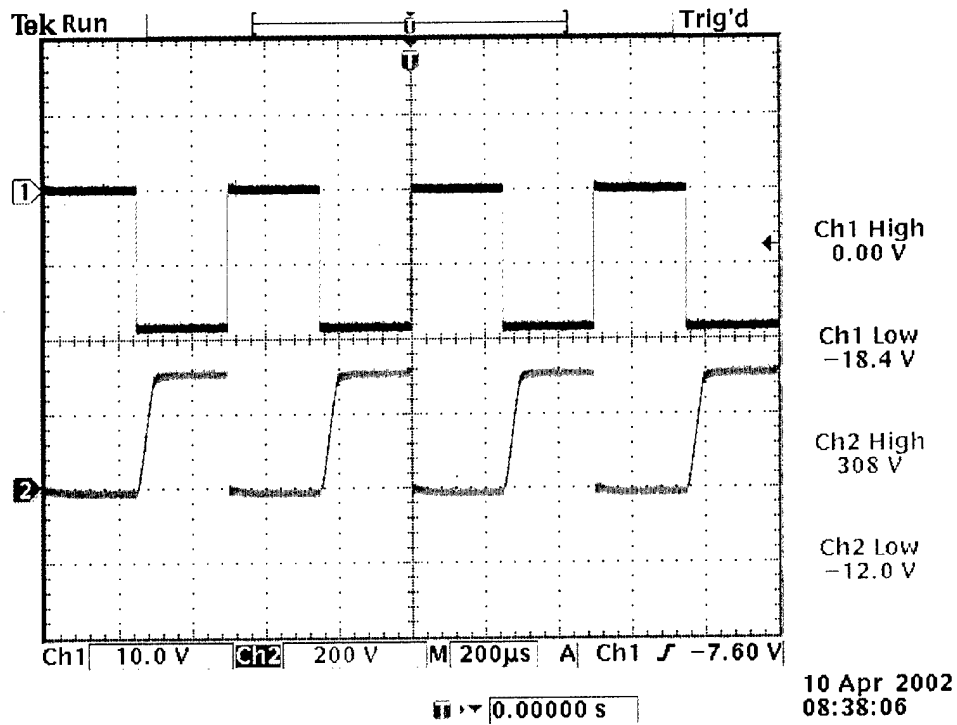

Fig. 12. High-voltage switch test of SiC SIT # 1205.

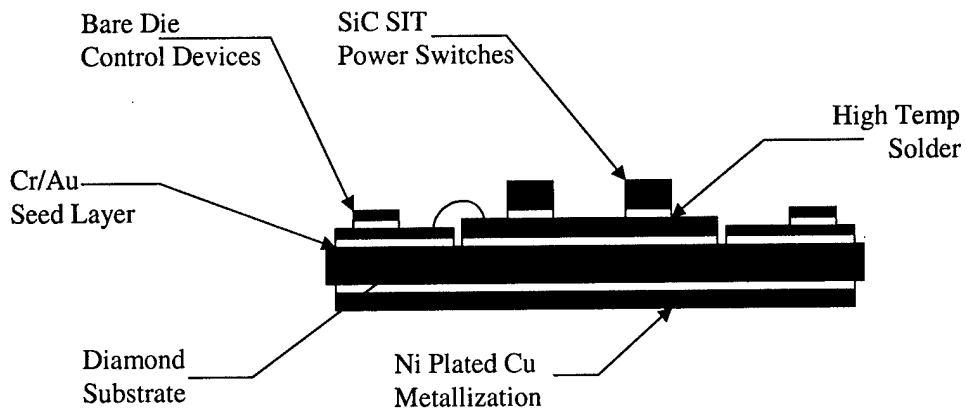

Fig. 13. SiC SIT-based power package built on a diamond substrate.

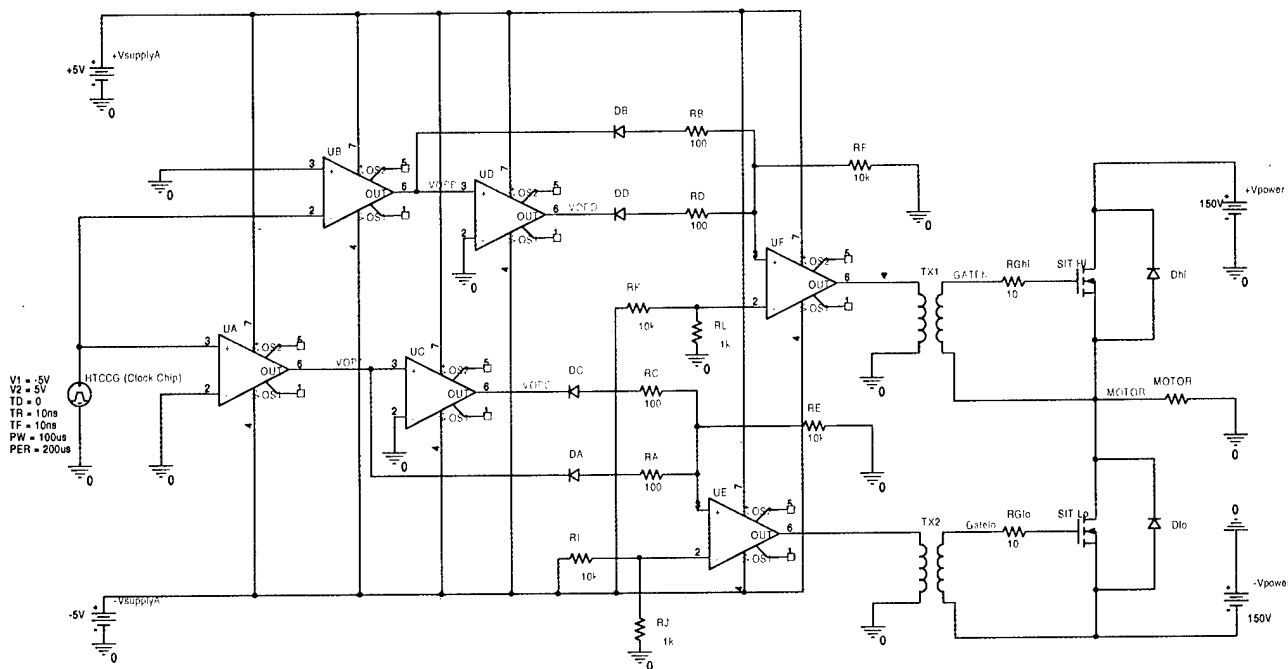

Fig. 14. Novel high-temperature half-bridge design.

References

- [1] N. S. Bernet, P. K. Steimer, T. Bruckner, O. Apledorn, "Characterization of IGCTs for Series Connected Operation," *Conference Record of the 2000 IEEE Industry Applications Society Annual Meeting*, Rome, Italy, October 8-12.
- [2] J. Sigg, M. Bruckmann, P. Turkes, "The Series Connection of IGBTs Investigated by Experiments and Simulation", *Conference Record of the 1996 IEEE Power Electronics Specialists Conference*, Vol. 2, pp. 1760-1765, Baveno, Italy, June 1996.
- [3] G. Busatto, B. Cascone, L. Fratelli, A. Luciano, "Series Connection of IGBTs in Hard Switching Applications," *Conference Record of the 1998 IEEE Industry Applications Society Annual Meeting*, St. Louis, Missouri, Oct 12-15, pp. 825-830.
- [4] P. Bhoopur, B. P. Schmitt, G. Neeser, "HV-IGBT Drives and Their Applications", *IEEE 1999 International Conference on Power Electronics and Drive Systems, PEDS'99*, July 1999, Hong Kong, pp. 585-590.
- [5] A. Consoli, S. Musumeci, G. Oriti, A. Testa, "Active Voltage Balancement of Series Connected IGBTs", *Conference Record of the 1995 IEEE Industry Applications Society Annual Meeting*, Vol. 3, pp. 2752-2758.
- [6] C. Gerster, P. Hofer, N. Karrer, "Gate-control strategies for snubberless operation of series connected IGBTs", *Conference Record of the 1996 IEEE Power Electronics Specialists Conference*, Vol. 2, pp. 1739-1742, Baveno, Italy, June 1996.
- [7] P. R. Palmer, A. N. Githiari, "The Series Connection of IGBT's with Active Voltage Sharing", *IEEE Transactions on Power Electronics*, Vol. 12, pp. 637-644, July, 1997.
- [8] G. Belverde, A. Galluzzo, M. Melito, S. Musumeci, A. Raciti, "Active Voltage Sharing of Series Connected Strings of IGBT Devices in Bridge Applications", *Conference Record of the 1998 IEEE Industry Applications Society Annual Meeting*, St. Louis (MO), Oct 12-15, 1998, pp. 817-824.

- [9] S. Hong, Y. G Lee, "Active Gate Control Strategy of Series Connected IGBTs for High Power PWM Inverter", *IEEE 1999 International Conference on Power Electronics and Drive Systems, PEDS'99, July 1999, Hong Kong*, pp. 646-652.
- [10] J. W. Baek, D. W. Yoo and H. G. Kim, "High Voltage Switch Using Series-Connected IGBTs with Simple Auxiliary Circuit", *Conference Record of the 2000 IEEE Industry Applications Society Annual Meeting, Rome, Italy, October 8-12*.
- [11] V. Chitta, S. Hong, D. A. Torrey, "Series Connection of IGBTs with Active Voltage Balancing", *Conference Record of the 1997 IEEE Industry Applications Society Annual Meeting, New Orleans (LA), October 5-9*, pp. 961-967.
- [12] A. Galluzzo, G. Belverde, M. Melito, S. Musumeci, A. Raciti, "Snubberless Balancement of Series Connected Insulated Gate Devices by a Novel Gate Control Strategy", *Conference Record of the 1997 IEEE Industry Applications Society Annual Meeting, New Orleans (LA), October 5-9*, pp. 975-982.
- [13] J. Saiz, M. Mermet D. Frey, P.O. Jeannin, "Optimization and Integration of an Active Clamping Circuit for IGBT series Connection", *Conference Record of the 2001 IEEE Industry Applications Society Annual Meeting, Chicago (IL), September 30- October 4*.
- [14] G. Belverde, A. Galluzzo, M. Melito, S. Musumeci, A. Raciti, "On The Series Connection of Insulated Gate Power Devices", *Proceedings of Third IEEE International Caracas Conference on Devices, Circuits and Systems, ICCDCS 00, March 15-17, 2000, Cancun, Mexico*, pp. 85.2-85.6.
- [15] H. G. Lee, Y. H. Lee, B. S. Suh, D. S. Hyun, "An Improved Gate Control Scheme for Snubberless Operation of High Power IGBTs", *Conference Record of the 1997 IEEE Industry Applications Society Annual Meeting, New Orleans (LA), Oct 5-9*, pp. 975-982.
- [16] S. Park, T. M. Jahns, "Flexible dv/dt and di/dt Control Method for Insulated Gate Power Switches", *Conference Record of the 2001 IEEE Industry Applications Society Annual Meeting, Chicago (IL), September 30- October 4*.
- [17] D. Zhou, D. H. Braun, "Digital Gating Control and Analog Delay Circuits Protect Multiple Cascode-Connected IGBTs", *Feature PCIM Article, PCIM June 2000*, pp. 28-34.
- [18] D. Zhou, D.H. Braun, "A Practical Series Connection Technique for Multiple IGBT Devices", *Conference Record of the 2001 IEEE Power Electronics Specialists Conference*, pp. 98-102, Vancouver (CA), June 18-21.
- [19] Harris, Properties of Silicon Carbide, INSPEC, London, United Kingdom, 1995.
- [20] Choyke, Matsunami, Pensl, Silicon Carbide: A Review of Fundamental Questions and Applications to Current Device Technology, Akademie Verlag, Berlin, Germany, 1997.
- [21] Materials for High-Temperature Semiconductor Devices, National Academy Press, Washington D.C., 1995.
- [22] Zverev, Treu, Kapels, Hellmund, Rupp, "SiC Schottky Rectifiers: Performance, Reliability, and Key Application", 2001 European Power Electronics Conference, Graz, Austria.
- [23] Phlippen and Burger, "A New High Voltage Schottky Diode Based on Silicon Carbide (SiC)", 2001 European Power Electronics Conference, Graz, Austria.
- [24] Lostetter, Olejniczak, Brown, Elshabini, "Silicon Carbide Power Die Packaging in Diamond Substrate Multichip Power Module Applications", 2001 IMAPS Conference, Baltimore.
- [25] Lostetter, Olejniczak, Brown, Elshabini, "The Utilization of Diamond and Diamond-Like Carbon Substrates for High-Performance Power Electronic Packaging Applications", 2001 European Power Electronics Conference, Graz, Austria.