

AD \_\_\_\_\_

Award Number: DAMD17-98-1-8131

TITLE: Mammary-Specific Targeting of the BRCA2 Breast Cancer Susceptibility Gene in Mice

PRINCIPAL INVESTIGATOR: Dr. Kimberly McAllister  
Dr. Roger Wiseman

CONTRACTING ORGANIZATION: National Institute of Health  
Research Triangle Park, North Carolina  
27709

REPORT DATE: December 2001

TYPE OF REPORT: Annual Summary

PREPARED FOR: U.S. Army Medical Research and Materiel Command  
Fort Detrick, Maryland 21702-5012

DISTRIBUTION STATEMENT: Approved for Public Release;  
Distribution Unlimited

The views, opinions and/or findings contained in this report are those of the author(s) and should not be construed as an official Department of the Army position, policy or decision unless so designated by other documentation.

20020816 099

# REPORT DOCUMENTATION PAGE

Form Approved  
OMB No. 074-0188

Public reporting burden for this collection of information is estimated to average 1 hour per response, including the time for reviewing instructions, searching existing data sources, gathering and maintaining the data needed, and completing and reviewing this collection of information. Send comments regarding this burden estimate or any other aspect of this collection of information, including suggestions for reducing this burden to Washington Headquarters Services, Directorate for Information Operations and Reports, 1215 Jefferson Davis Highway, Suite 1204, Arlington, VA 22202-4302, and to the Office of Management and Budget, Paperwork Reduction Project (0704-0188), Washington, DC 20503

<b>1. AGENCY USE ONLY (Leave blank)</b>		<b>2. REPORT DATE</b> December 2001	<b>3. REPORT TYPE AND DATES COVERED</b> Annual Summary (1 Nov 00 - 1 Nov 01)	
<b>4. TITLE AND SUBTITLE</b> Mammary-Specific Targeting of the BRCA2 Breast Cancer Susceptibility Gene in Mice			<b>5. FUNDING NUMBERS</b> DAMD17-98-1-8131	
<b>6. AUTHOR(S)</b> Dr. Kimberly McAllister Dr. Roger Wiseman				
<b>7. PERFORMING ORGANIZATION NAME(S) AND ADDRESS(ES)</b> National Institute of Health Research Triangle Park, North Carolina 27709  E-Mail: Mcallis2@niehs.nih.gov			<b>8. PERFORMING ORGANIZATION REPORT NUMBER</b>	
<b>9. SPONSORING / MONITORING AGENCY NAME(S) AND ADDRESS(ES)</b> U.S. Army Medical Research and Materiel Command Fort Detrick, Maryland 21702-5012			<b>10. SPONSORING / MONITORING AGENCY REPORT NUMBER</b>	
<b>11. SUPPLEMENTARY NOTES</b>				
<b>12a. DISTRIBUTION / AVAILABILITY STATEMENT</b> Approved for Public Release; Distribution Unlimited				<b>12b. DISTRIBUTION CODE</b>
<b>13. ABSTRACT (Maximum 200 Words)</b> The breast cancer susceptibility gene BRCA2 is known to be responsible for a substantial portion of inherited breast cancer. An appropriate animal model is necessary to determine how specific defects in <i>Brca2</i> strongly predispose to breast tumorigenesis. We therefore proposed to generate mice carrying a conditional <i>Brca2</i> mutation whereby <i>Brca2</i> would be disrupted specifically in the mammary tissue by gene targeting with the Cre-loxP system. We also proposed to generate homozygous <i>Brca2</i> germline knockout mice. These homozygous <i>Brca2</i> -mutant mice have a significantly increased overall tumor incidence compared to their heterozygous littermates. In addition, a long-term study was initiated to examine the effect of radiation on tumor development in mice with germline mutations of <i>Brca2</i> and <i>p53</i> . We have found mammary tumor development to occur beginning at seven months of age in animals irradiated at 5 Gy that were hemizygous for both the <i>Brca2</i> and <i>p53</i> mutation. Tumor latency appears to be significantly decreased in mice homozygous for the <i>Brca2</i> exon 27 mutation compared to littermates, regardless of <i>p53</i> genotype. We believe these distinct animal models will be useful to further clarify the role of <i>Brca2</i> in mammary tumorigenesis.				
<b>14. SUBJECT TERMS</b> Breast Cancer, Brca2, Cre-loxP, tissue-specific gene targeting			<b>15. NUMBER OF PAGES</b> 38	
			<b>16. PRICE CODE</b>	
<b>17. SECURITY CLASSIFICATION OF REPORT</b> Unclassified	<b>18. SECURITY CLASSIFICATION OF THIS PAGE</b> Unclassified	<b>19. SECURITY CLASSIFICATION OF ABSTRACT</b> Unclassified	<b>20. LIMITATION OF ABSTRACT</b> Unlimited	

## Table of Contents

Cover.....	1.
SF 298.....	2.
Table of Contents.....	3.
Introduction.....	4.
Body.....	4.
Key Research Accomplishments.....	9.
Reportable Outcomes.....	9.
Conclusions.....	10.
References.....	11.
Appendices.....	12-38.

## Mammary-Specific Targeting of the *Brca2* Breast Cancer Susceptibility Gene in Mice

### Introduction:

As the second leading cause of cancer mortality and the most commonly diagnosed neoplasm for women, breast cancer carries an enormous physical, emotional, and financial burden. Women with inherited mutations in the BRCA2 gene have a very high lifetime risk of developing breast cancer. An appropriate animal model is necessary to determine how specific defects in *Brca2* strongly predispose to breast tumorigenesis. We therefore proposed to generate mice carrying a conditional *Brca2* mutation whereby *Brca2* would be disrupted specifically in the mammary tissue by gene targeting with the Cre-loxP system. We are using these animals to investigate the role of various reproductive events and the effect of radiation on breast cancer risk or protection. We also successfully attempted to generate homozygous *Brca2* germline knockout mice. Unlike previously described *Brca2* knockout mice that display predominantly embryonic lethal phenotypes, we were able to develop mice with a homozygous germline deletion of *Brca2* exon 27 that exhibits only a moderate decrease in viability and are fertile. These homozygous germline *Brca2*-mutant mice have a significantly increased overall tumor incidence and decreased survival compared to their heterozygous littermates. We have also initiated a long-term study to examine the effect of radiation on tumor development in mice with germline mutations of *Brca2* and *p53*. We have found mammary tumor development to occur beginning at seven months of age in irradiated animals that were hemizygous for both the *Brca2* and *p53* mutation. Tumor latency appears to be significantly decreased in mice homozygous for the *Brca2* exon 27 mutation compared to littermates, regardless of *p53* genotype. We believe these distinct animal models will be useful to further clarify the role of *Brca2* in mammary tumorigenesis.

### Body:

Statement of Work Summary: We have now completed Tasks 1, 2, and 3 of Technical Objective 1: Development of mammary gland-specific *Brca2*-deficient mice. Mice with a mammary-specific mutation in exon 27 of *Brca2* have now been generated as well as a homozygous germline  $\Delta 27$  *Brca2* mutation. We have also completed Task 4 of Technical Objective 1 by establishing the germline  $\Delta 27$  *Brca2* mouse lines onto several inbred strain backgrounds, including C57BL/6, BALB/cJ and SWR/J.

We have now completed the long-term analysis of the results of the germline *Brca2* mutation on mammary gland formation and tumorigenesis. We are also analyzing the final long-term results of this mammary-specific mutation on tumorigenesis now as stated in Task 1 of Technical Objective 2: Analyses of mammary gland-specific *Brca2*-deficient mice. We have attempted to isolate mammary epithelial cells from these animals for the proposed *in vitro* work proposed in Task 2 and 3 of Technical Objective 2. We have isolated murine embryonic fibroblast cultures from wildtype and homozygously deleted exon 27 *Brca2* cells, and we have attempted to assess apoptosis rates, growth rates, and sensitivity to radiation for these cells. We have also begun to use various expression technologies to compare gene expression levels between these distinct

populations of cells (as stated in Task 4, Technical Objective 2). We have begun to analyze several long-term studies attempting to assess the impact of radiation exposure for our conditional and germline *Brca2* knockout animals (as stated in Task 5, Technical Objective 2). Specifically, the conditional knockout animals and their corresponding age-matched controls were irradiated at 5 weeks of age and are being evaluated currently for mammary tumor formation as well as an increased incidence of tumorigenesis in other tissue sites as well. We have also initiated a long-term study to examine tumor development in mice with germline mutations of both *Brca2* and *p53* that were irradiated at defined doses at 5 weeks of age.

### **Specific Aims 1, 2, 3, 4, 5:**

We have strived to generate an appropriate animal model for breast cancer by disrupting the *Brca2* gene in the mouse. Our original attempt to generate a *Brca2* knockout mouse (by introducing a stop codon into exon 10) resulted in an early (day 7-9) embryonic lethal phenotype in the homozygous state which is modified by genetic strain background (Bennett, et al. 2000). We have now generated a conditional knockout mouse model for *Brca2* that would allow the deletion of the final exon of the gene at a later time in the mammary gland.

In the generation of this conditional *Brca2* mouse knockout, the mouse homologue of BRCA2 has been disrupted through the use of a targeting construct, which has the final exon of the gene, exon 27, flanked by loxP sites. A single loxP site was inserted into intron 26 and into a downstream region beyond the *Brca2* stop codon. This "floxed" targeting vector was introduced into ES cells by electroporation and a properly targeted ES cell clone was identified. Germline transmission of the *Brca2* floxed allele was then obtained using standard knockout protocols and procedures and the homozygous floxed animals were confirmed to have no detrimental phenotype. The puberty-specific deletion of *Brca2* exon 27 in the mammary tissue has been performed by crossing homozygous *Brca2* floxed mice with an MMTV-Cre transgenic mouse strain. The Cre recombinase activity is restricted to mammary tissues by activation of a murine mammary tumor virus (MMTV) promoter with the onset of ovarian function during puberty in this transgenic mouse strain (Wagner, et al. 1997).

A successful colony of these animals that should become defective for *Brca2* function specifically in the mammary gland during puberty have now been generated. We have been able to confirm the activation of Cre in the mammary gland epithelial cells during the onset of puberty for the MMTV-Cre transgenic strain (MMTV-Cre strain D) we have used by taking advantage of a Cre reporter mouse strain (Soriano, 1999) whereby Cre-mediated lacZ expression can be detected by standard histological procedures (Wagner, et al., 2001). This has allowed us to be confident that *Brca2* inactivation in this conditional knockout model would occur in the target mammary epithelial cells. We have now completed an extensive profile of expression of Cre in this MMTV-Cre transgenic strain which we hope to correlate with the organ tumorigenesis profile we obtain with our *Brca2* conditional knockout animals.

The conditional knockout animals and their corresponding age-matched controls are presently being examined for distinct mammary gland changes with and without the

additional environmental insult of irradiation. Approximately 60 animals of each genotype were irradiated with 5 Gy at 5 weeks of age. All mammary gland alterations including preneoplastic changes and mammary tumor incidence for these mice are being assessed. Mice from each genotypic class are being sacrificed presently at interim dates (2, 3, 6, 9, 12, and 15 months of age). We hope to do a final terminal sacrifice at 24 months of age for these animals.

A preliminary pilot experiment was also performed to attempt to investigate the role of various reproductive events associated with breast cancer risk or protection in humans. In addition to following a hundred virgin *Brca2* conditional animals, the effect of pseudopregnancy and full-term pregnancy with or without lactation was analyzed in a small number of animals. Twenty female mice of each informative genotype have been housed with vasectomized males to induce and maintain a pseudopregnant state. Ten female mice of each informative conditional *Brca2* genotype have been bred with males through at least three rounds of pregnancy without lactation, forcing them to undergo multiple cycles of pregnancy induced proliferation and differentiation followed by involution. Finally, twenty female mice of each informative conditional *Brca2* genotype are being continuously bred with males and allowed to lactate until natural weaning of pups. These female animals were not forced to undergo involution until three cycles of pups have been raised. A large 22-month terminal sacrifice was recently performed for each of these classes of conditional knockout animals. We observed that approximately 51% of the virgin homozygous *Brca2* floxed animals with Cre had masses upon gross necropsy compared to 33% for the control virgin animals (homozygous *Brca2* floxed animals without Cre), which is approaching statistical significance. The tumor spectrum present in these conditional knockout animals and their corresponding controls appears to be broad. We did observe a few tumor types in all classes of animals at this 22-month timepoint that were only seen in the Cre+ animals, such as lung masses (6 in Cre+ vs. 0 in Cre-) and liver masses (6 in Cre+ vs. 0 in Cre-). There did not appear to be a significant difference in the Cre+ and Cre- animals for the pseudopregnant group or the multiparous groups as explained above. However, we observed 5 animals with Cre in the no lactation group that had masses compared to only one animal without Cre in the no lactation group (for animals sacrificed at 22-months and morbid sacrifices). Although this is a very small preliminary experiment, these results suggest that further study to investigate the role of breastfeeding or lactation in tumor suppression might be of interest.

In parallel studies, I have also generated a germline deletion of *Brca2* exon 27 by transiently transfecting embryonic stem cells carrying the conditional *Brca2* allele with *Cre*. These experiments have created the first known germline homozygous *Brca2* knockout animals that appear to exhibit a moderate decrease in perinatal viability and are fertile. We observed untreated animals for tumor development or signs of morbidity for up to 18 months of age and then completed a final terminal sacrifice of the remaining animals between 17 and 19 months of age. We have just recently submitted this manuscript for publication in *Cancer Research* (McAllister, *et al.* 2001-submitted manuscript enclosed in appendice). These homozygous *Brca2*-mutant mice have a significantly increased overall tumor incidence and decreased survival compared to their heterozygous littermates. Ten out of 11 spontaneous tumors that developed prior to 17 months arose in homozygous *Brca2*-mutant mice, which suggests that the latency of

tumor development is significantly affected by the presence of this *Brca2* mutation. The tumor spectrum is diverse and includes carcinomas, adenomas, lymphomas, and sarcomas. One interesting finding of this study is the exclusive presence of carcinomas in homozygous *Brca2*-mutant mice, especially a substantial number of stomach cancers. Interestingly, stomach cancers are among the various tumor types that have been associated with BRCA2 mutations in humans. Although we did not observe many mammary tumors from this study, we believe animals carrying this *Brca2* mutation will be more susceptible to mammary tumorigenesis if placed on a more susceptible strain. We were particularly interested in placing this *Brca2* mutation onto the BALB/cJ and SWR/J strain that are known to be much more susceptible to mammary carcinogenesis. We have therefore used speed congenics techniques to transfer this *Brca2* exon 27 mutation onto these strains quickly and have recently completed the final generation 5 of these backcrosses for both strains (Markel, *et al.* 1997 ; Wakeland, *et al.* 1997).

Preliminary results from a six month timepoint sacrifice of six germline *Brca2* knockout animals also showed an obvious inhibited ductal branching morphology in the mammary glands of three homozygous *Brca2* mutant animals compared to one wildtype and two heterozygous littermates. We believe that these results suggest the likelihood of an increased susceptibility to mammary tumor formation after a longer latency period or in combination with additional carcinogenic exposures or environmental insults based on the results from previous a *Brca1* animal model. Conditional homozygous *Brca1* animals initially displayed a similar severe inhibition of mammary ductal branching (Xu, *et al.* 1999). The conditional *Brca1* mice (which were generated with the same MMTV-Cre transgenic mice which we are utilizing for our conditional *Brca2* knockout studies) developed subsequent mammary tumor formation after a long latency period (10-13 months of age) with pathology similar to human breast cancer.

We have also initiated a collaboration with Dr. Mitch Eddy to analyze an additional spermatogenesis phenotype for the germline animals disrupted for this *Brca2* mutation. We have observed a partial disruption of spermatogenesis in the homozygous *Brca2* germline animals. This phenotype appears to be more pronounced and associated with infertility in homozygous germline *Brca2* animals generated by crossing the homozygous floxed *Brca2* animals with a unique MMTV-Cre transgenic strain. We are currently writing a manuscript to document this phenotypic difference in germline *Brca2* knockout mice generated by two very different methods.

Given the surprising viability of the homozygous  $\Delta 27$  *Brca2* knockout animals, a similar experimental design to examine the effects of radiation was initiated for these animals as was performed for the conditional  $\Delta 27$  *Brca2* knockouts. We believe the susceptibility of the *Brca2* mutant animals to mammary gland tumorigenesis will be enhanced by placing the animals on a *p53*-deficient background. The *p53* tumor suppressor is frequently mutated in human breast cancer and studies have suggested that *Brca2* and *p53* deficiencies may have an additive effect on breast tumor development (Greenblatt, *et al.* 2001; Xu *et al.* 1999). We have therefore initiated a long-term study irradiating five-week old animals at 5 Gy or .3 Gy that are either heterozygous or homozygous for one or both the exon 27 deletion of *Brca2* as well as a *p53* null mutation. Based on gross necropsy results, lymphomas predominated the tumor spectrum at 5 Gy and tumor incidence correlated with the presence of the *p53* mutation. However, tumor latency appears to be significantly decreased in mice homozygous for the *Brca2* mutation

compared to littermates, regardless of *p53* genotype. Mammary tumors began to develop by seven months after exposure in animals irradiated at 5 Gy that were hemizygous for both the *Brca2* and *p53* mutation. Interestingly, mice irradiated at .3 Gy had substantially fewer lymphomas and a corresponding increased mammary tumor incidence. The pathology on these animals is currently being read. We plan to complete this study by March of 2002 and finish analyzing this data.

We have established a variety of *Brca2*-deficient cells from the germline *Brca2* knockout animals, and we have initiated several collaborations to begin to use these resources for *in vitro* biochemical studies. Murine embryonic fibroblast (MEF) cultures have been generated from intercrosses of heterozygous germline *Brca2* knockout animals as well as intercrosses of double heterozygous *Brca2/p53* knockout animals. We attempted to assess the growth rates and sensitivity to radiation for these cells. However, we could not establish a reproducible significant difference between cells of different genotypes which may reflect the limitations of the assays that were used. We have also recently initiated collaborations with Dr. Fergus Couch, Mayo Clinic, to assess the apoptosis rates of these cells. We also attempted to establish murine mammary epithelial cells from the conditional and germline exon 27 *Brca2*-deficient animals as these cells are believed to be the key target cell type susceptible to mammary tumorigenesis in humans and mice. We have not been successful to date in obtaining murine mammary epithelial cells due to the difficulties in establishing these cells long-term in culture. In addition, we have generated embryonic stem cells that are homozygous for the deletion of exon 27 *Brca2* by retargeting of the  $\Delta 27$  ES cells with the flox targeting construct followed by electroporating with a Cre plasmid. Finally, we initiated a collaboration with Dr. Laura Hale, Duke University, and Kristina Flores to assess the effect of this *Brca2* mutation in thymocytes where *Brca2* is known to be highly expressed. This exon 27 *Brca2* mutation was found to affect thymus cellularity and thymocyte apoptosis. (This manuscript is currently being written-see Flores *et al.* in Reportable Outcomes).

We are interested in examining the specific changes in gene expression for *Brca2*-deficient cells compared to wildtype controls. We plan to utilize the murine cDNA microarray system established by the NIEHS cDNA Microarray Center to examine differences in gene expression patterns for mammary tumors generated from the combined *Brca2/p53* radiation experiment. We would like to compare mammary tumors that have the homozygous  $\Delta 27$  *Brca2* mutation with similar mammary tumors without the *Brca2* mutation to begin to dissect the molecular changes involved in *Brca2*-initiated mammary tumorigenesis. We would also like to generate preliminary expression profiles for these tumors. We have begun to develop a quantitative TaqMan RT-PCR analysis of specific genes of interest, including *p53*, *p21*, and others that may be downstream of *Brca2* in molecular pathways disrupted in tumorigenesis. We hope to be able to extend these studies using mammary epithelial cells in the future as well. Finally, we would also like to correlate these *in vitro* studies to *in vivo* alterations by directly examining mammary gland tissue from these animals for gene expression analyses in the future.

### Key Research Accomplishments:

- 1) Embryonic lethality of the initial  $\Delta 10/11$  *Brca2* mutation shown to be altered by genetic background
- 2) Generation of mice with germline transmission of the floxed *Brca2* allele; Subsequent mammary-specific deletion of *Brca2* generated by crossing *Brca2* floxed mice with MMTV-Cre transgenic mice
- 3) Specificity of MMTV-Cre strain D transgene confirmed with the use of LacZ (Rosa26) reporter mice
- 4) Generation of viable and fertile germline homozygous  $\Delta 27$  *Brca2* mice by two distinct methods
- 5) Potential mammary gland and spermatogenesis phenotypes identified in germline homozygous  $\Delta 27$  *Brca2* mice
- 6) Susceptibility of germline homozygous  $\Delta 27$  *Brca2* mice to tumor development and comprehensive tumor spectrum for these mice established
- 7) Generation of homozygous  $\Delta 27$  *Brca2* ES cells and murine embryonic fibroblast cultures for *in vitro* studies
- 8) Analysis of irradiated mice carrying both a *p53* and *Brca2* mutation display substantial mammary tumor development beginning at 7 months of age; Tumor latency appears to be significantly decreased in germline homozygous  $\Delta 27$  *Brca2* mice.

### Reportable Outcomes:

Bennett, L.M., McAllister, K.A., Blackshear, P.E., Malphurs, J., Collins, N.K., Ward, T., Bunch, D.O., Goulding, G., Gowen, L., Koller, B., Eddy, M.E., Davis, B.J., and Wiseman, R.W. *Brca2*-Null Embryonic Survivability is prolonged on the BALB/c Genetic Background. *Molecular Carcinogenesis* 28: 174-183, 2000.

Thangaraju, M., Wu, K., Kottke T., McAllister, K.A., Wiseman, R.W., Ingle, J.N., Lingle, W., Kaufmann, S.H., and Couch, F.J. BRCA2 modulates the apoptotic response to cellular stress. Manuscript in progress.

Wagner, K.-U., McAllister, K.A., Ward, T., Davis, B., Wiseman, R., and Hennighausen, L. Spatial and temporal expression of the Cre gene under the control of the MMTV LTR in different transgenic lines. *Transgenic Research*, in press, 2001.

Flores, K. G., McAllister, K.A., Greer, P.K., Wiseman, R.W., and Hale, L. P. BRCA2 is differentially expressed during thymocyte development and regulates thymocyte apoptosis. Manuscript in progress.

K.A. McAllister, L. M. Bennett, C. D. Houle, T. Ward, J. Malphurs, N. K. Collins, C. Cachafeiro, J. Haseman, E. H. Goulding, D. Bunch, E. M. Eddy, B. J. Davis, and R. W. Wiseman. Cancer Susceptibility of Mice with a Homozygous Deletion in the C-Terminal Domain of the *Brca2* Gene. Submitted to Cancer Research, 2001.

Poster presentations of this research occurred at: a 1999 AACR Special Conference, Keystone, Colorado entitled "Cancer Biology and the Mutant Mouse: New Methods, New Models, New Insights", the 2000 and 2001 AACR meetings, the 2002 Mammary Gland Gordon Conference, the 2000 Department of Defense Era of Hope meeting, the Second and Third International Workshop on the Function of BRCA1 and BRCA2, and a 2001 EMS (Environmental Mutagen Society) meeting entitled "Breast Cancer and Environmental Mutagens: Bridging Molecular Research to Medicine and Public Health".

Author applied for and received a NIEHS TIP (Transition to Independent Position) grant this summer through a career transition (K22) mechanism based on work supported by this award.

### **Conclusions:**

The early embryonic lethality of all previously generated *Brca2* null mice impeded functional analyses of *Brca2* in normal mammary gland development and its role in neoplasia. We therefore proposed and have now successfully completed the generation of both a mammary-specific and germline disruption of *Brca2*. We are currently investigating the role of various reproductive events known to be protective for breast cancer in women in these conditional *Brca2* knockout animals. We are also using this conditional *Brca2* animal model to study the effects of environmental insults such as radiation on tumorigenesis. An extensive examination of our complementary germline *Brca2* knockout animals reveals a limited loss of viability compared to all other germline *Brca2* knockout animals reported to date. These homozygous *Brca2*-mutant mice have a significant increased tumor incidence for a wide spectrum of tumors. Our studies with these germline *Brca2* knockout animals and cells generated from them support a strong correlation between the *Brca2* mutation position and the resulting *Brca2* mouse knockout phenotype. These studies demonstrate the functional significance of the C-terminal domain of *Brca2*. The significant viability and cancer predisposition of the germline *Brca2* knockout animals will make them useful animal models to continue to study the role of *Brca2* in breast cancer alone or in combination with other breast cancer susceptibility genes, such as *p53*.

## References:

Bennett, L.M., McAllister, K.A., Blackshear, P.E., Malphurs, J., Collins, N.K., Ward, T., Bunch, D.O., Goulding, G., Gowen, L, Koller, B., Eddy, M.E., Davis, B.J., and Wiseman, R.W. *Brca2*-Null Embryonic Survivability is prolonged on the BALB/c Genetic Background. *Molecular Carcinogenesis* 28: 174-183, 2000.

Greenblatt, M.S., Chappuis, P.O., Bond, J.P., Hamel, N., and Foulkes, W.D. TP53 mutations in breast cancer associated with BRCA1 or BRCA2 germ-line mutations: Distinctive spectrum and structural distribution. *Cancer Research* 61 (10): 4092-4097, 2001.

Markel, P., Shu, P., Ebeling C., Carlson, G.A., Nagle, D.L., Smutko, J.S., and Moore, K.J. Theoretical and empirical issues for marker-assisted breeding of congenic mouse strains. *Nature Genetics* 17: 280-284, 1997.

McAllister, K.A., Bennett, L. M., Houle, C. D., Ward, T., Malphurs, J., Collins, N. K., Cachafeiro, C., Haseman, J., Goulding, E. H , Bunch, D., Eddy, E. M., Davis, B. J., and Wiseman, R. W. Cancer Susceptibility of Mice with a Homozygous Deletion in the C-Terminal Domain of the *Brca2* Gene. Submitted to *Cancer Research*, 2001.

Soriano, P. Generalized lacZ expression with the ROSA26 Cre reporter strain. *Nature Genetics* 21:70-71, 1999.

Wagner, K.-U., Wall, R.J., St-Onge,L., Gruss, P., Wynshaw-Boris, A., Garrett, L., Li, M., Furth, P.A. and Hennighausen, L. Cre-mediated gene deletion in the mammary gland. *Nucleic Acids Research* 25: 4323-4330, 1997.

Wagner, K.-U., McAllister, K.A., Ward, T., Davis, B., Wiseman, R., and Hennighausen, L. Spatial and temporal expression of the Cre gene under the control of the MMTV LTR in different transgenic lines. *Transgenic Research*, in press, 2001.

Wakeland, E., Morel, L., Achey, K., Yui, M., and Longmate, J. Speed Congenics: a classic technique in the fast lane (relatively speaking). *Immunology Today* 18: 472-277, 1997.

Xu, X., Wagner, K.-U., Larson, D., Weaver, Z., Li, C., Ried, T., Hennighausen, L., Wynshaw-Boris, A., and Deng, C.-X. Conditional mutant of *Brcal* in mammary epithelial cells results in blunted ductal morphogenesis and tumour formation. *Nature Genetics* 22: 37-42, 1999.

**Appendices:**

Enclosed:

K.A. McAllister, L. M. Bennett, C. D. Houle, T. Ward, J. Malphurs, N. K. Collins, C. Cachafeiro, J. Haseman, E. H. Goulding, D. Bunch, E. M. Eddy, B. J. Davis, and R. W. Wiseman. Cancer Susceptibility of Mice with a Homozygous Deletion in the C-Terminal Domain of the *Brca2* Gene. Submitted to Cancer Research, 2001.

# Cancer Susceptibility of Mice with a Homozygous Deletion in the C-Terminal Domain of the *Brca2* Gene

K.A. McAllister<sup>1</sup>, L. M. Bennett<sup>2</sup>, C. D. Houle<sup>1</sup>, T. Ward<sup>1</sup>, J. Malphurs<sup>1</sup>, N. K. Collins<sup>1</sup>, C. Cachafeiro<sup>3</sup>, J. Haseman<sup>4</sup>, E. H. Goulding<sup>5</sup>, D. Bunch<sup>6</sup>, E. M. Eddy<sup>5</sup>, B. J. Davis<sup>1</sup>, and R. W. Wiseman<sup>1</sup>.

Running Title: Cancer Susceptibility in Homozygous Mutant *Brca2* Mice

Key Words: *Brca2*, breast cancer, gene targeting, *Cre/loxP*, tumorigenesis

<sup>1</sup> Laboratory of Women's Health, National Institute of Environmental Health Sciences, NIH, 111 T.W. Alexander Drive, Research Triangle Park, NC 27709

<sup>2</sup> Biology and Biotechnology Research Program, P.O. Box 808, L-448, Lawrence Livermore National Laboratory, 7000 East Ave., Livermore, CA 94551

<sup>3</sup> Integrated Laboratory Systems, Inc., 800-12 Capitola Drive, Durham, NC 27713

<sup>4</sup> Biostatistics Branch, National Institute of Environmental Health Sciences, NIH, 111 T.W. Alexander Drive, Research Triangle Park, NC 27709

<sup>5</sup> Laboratory of Reproductive Development and Toxicology, National Institute of Environmental Health Sciences, NIH, 111 T.W. Alexander Drive, Research Triangle Park, NC 27709

<sup>6</sup> Department of Medicine, 317 MacNider CB# 7155, University of North Carolina, Chapel Hill, NC 27599

Please address all correspondence to: Dr. Kimberly A. McAllister, Ph.D., Research Fellow, Laboratory of Women's Health, MD C4-06, Rall Building, National Institute of Environmental Health Sciences, NIH, 111 T.W. Alexander Drive, Research Triangle Park, NC 27709 (919) 541-3229, Fax (919) 541-3720, [mcallis2@niehs.nih.gov](mailto:mcallis2@niehs.nih.gov)

## Abstract

Inherited mutations of the human BRCA2 gene confer increased risks for developing breast, ovarian and several other cancers. Unlike previously described *Brca2* knockout mice that display predominantly embryonic lethal phenotypes, we developed mice with a homozygous germline deletion of *Brca2* exon 27 that exhibit a moderate decrease in perinatal viability and are fertile. We deleted this *Brca2* C-terminal domain because it interacts directly with the *Rad51* protein, contains a nuclear localization signal and is required to maintain genomic stability in response to various types of DNA damage. These homozygous *Brca2*-mutant mice have a significantly increased overall tumor incidence and decreased survival compared to their heterozygous littermates. Virgin female mice homozygous for this *Brca2* mutation also display an inhibition of ductal side branching in the mammary gland at six months of age. Given their substantial viability and cancer predisposition, these mutant mice will be useful to further define the role of the C-terminal *Brca2* domain in tumorigenesis both *in vivo* and *in vitro*.

## Introduction

Women who inherit germline defects of the BRCA2 breast cancer susceptibility gene have up to an 85% risk of breast cancer development by 70 years of age (1,2). BRCA2 mutation carriers also have increased risks for a variety of cancers including ovarian, pancreatic, colon, prostate, stomach, laryngeal, thyroid, male breast cancer and ocular melanoma (3). Substantial evidence from studies of human and mouse cells indicates that the BRCA2 protein is an important component in DNA damage response pathways and loss of this function is considered a major factor in cancer predisposition (4,5). *Brca2*-mutant cells and embryos are hypersensitive to ionizing radiation and other DNA damaging agents and develop numerous spontaneous chromosomal abnormalities (6-10). In addition, several domains of the BRCA2 protein appear to interact directly with RAD51, a protein having distinct roles in normal meiotic and mitotic recombination, DNA damage repair, and chromosome segregation. These BRCA2 domains include the BRC repeats in exon 11 and a highly conserved RAD51 binding domain in exon 27 (6, 11-13). The interaction of *Brca2* with *Rad51* is pivotal for the role *Brca2* plays in the activation of double-strand break repair and/or homologous recombination and disruption of these processes may predispose individuals to cancer development.

Functional studies of *Brca2* in adult tissues have been hindered by the embryonic lethal phenotypes of *Brca2* knockout mice reported to date (14). We and others previously described mutant mice with disruptions in the 5' half of *Brca2* that result in embryonic lethality during early to mid-gestation (6, 15-17). The few homozygous mutant *Brca2* mice that have been reported to survive to adulthood display gross developmental abnormalities, are infertile, and develop thymic lymphomas by five

months of age (7, 8). Here, we describe the creation and initial phenotypic characterization of mutant mice that carry a homozygous germline deletion of exon 27 of the *Brca2* gene. We chose to target exon 27 because a *Rad51* binding domain has been identified between *Brca2* amino acids 3196-3232 in yeast two-hybrid studies (6, 11). In addition, this C-terminal domain of the *Brca2* protein contains nuclear localization signals that have been highly conserved among species (18, 19). Finally, cells lacking this C-terminal domain are hypersensitive to  $\gamma$ -radiation (10) and they have recently been shown to be deficient in error-free homology-directed DNA repair (20, 21). The *Brca2*-mutant mice described in this report exhibit a low penetrance of perinatal lethality and an increased susceptibility to spontaneous tumorigenesis in a variety of tissues.

## Materials and Methods

**Targeting Construct Design.** A targeting construct was generated that contained exon 27 of the *Brca2* gene flanked by *loxP* sites (Figure 1). The 5' targeting fragment consisted of a 4 kb *EcoRI* fragment containing exons 25, 26, and 27 and this was subcloned from a genomic mouse BAC clone (18). Likewise, a 3 kb *NsiI* fragment distal to the 3' untranslated region of *Brca2* was also subcloned. Double-stranded *loxP* oligonucleotides flanked by appropriate restriction sites were inserted into a *MunI* site in intron 26 of the 5' targeting fragment and a *Bam HI* site of the 3 kb *Nsi* targeting fragment. Both fragments were then inserted into a previously described pgkNeoTK targeting vector (17). Following linearization with *Sal I*, this targeting vector was introduced into 129/Ola-derived BK-4 embryonic stem (ES) cells by electroporation as

previously described (17). Electroporated cells were subjected to positive and negative selection with geneticin (250 µg/ml; Gibco/BRL, Rockville, MD) and gancyclovir (2 µM; Roche, Hertfordshire, UK). A properly targeted ES cell clone with the “floxed” *Brca2* allele (*Brca2<sup>Flox27</sup>*) was identified by Southern analyses with unique probes outside the *Brca2* targeting construct as well as PCR analyses using *loxP*-specific primers.

**Generation of Germline Mutant Mice.** A Cre-expression plasmid (generously provided by Dr. Robert Sobol, NIEHS) was transiently electroporated into embryonic stem cells carrying a single floxed *Brca2* allele. This *Brca2* allele was successfully deleted in approximately 10% of the floxed ES cells as determined by PCR using primers that flanked the 5' and 3' *loxP* sites (Figure 1). The *Brca2<sup>Wildtype</sup>* and *Brca2<sup>Flox27</sup>* alleles were amplified using the following PCR primers: B2F1 5'- GGAGGAGGAGGAGTTGTTGA3' and B2R1 5'- ATCTCGTTCTCTCCACTCCA3' while the *Brca2<sup>Δ27</sup>* allele was detected using primers B2F1 and B2R2 5'- CAAAAAAGCCCAGATGATGAG3'. *Brca2<sup>Δ27</sup>* ES cells were then injected into C57BL/6N blastocysts and transplanted into pseudopregnant CD-1 females. Eight chimeras were generated and germline transmission of their *Brca2<sup>Δ27</sup>* allele was obtained by standard breeding techniques. Genomic DNA from pups was isolated from tail biopsies at weaning for genotyping by PCR.

**Mice and Tissues.** Mice carrying the *Brca2<sup>Δ27</sup>* mutation were backcrossed from a targeted 129-derived chimeric founder onto the C57BL/6N background for one to three generations, followed by intercrosses to generate mice homozygous for the *Brca2*-exon 27 deletion. Both virgin and multiparous females as well as males carrying this *Brca2<sup>Δ27</sup>* mutation were group housed in plastic cages on pressed wood-chip bedding.

Animals had access to an NIH-31 diet (18% protein, 4% fat, 5% fiber; Zeigler Bros., Gardeners, PA) and water *ad libitum*. Mice were monitored for 17 months and were sacrificed when palpable tumors developed or when signs of morbidity became apparent. Terminal sacrifices were performed on all surviving animals between 17 and 19 months of age. All tissue and tumor samples were removed post-mortem and fixed in 10% neutral buffered formalin. Specimens were processed for routine histology, embedded in paraffin, sectioned, and stained with hemotoxylin and eosin. Histological examination was performed by veterinary pathologists (CH and BD). In all mice, the right #4 and #5 mammary glands were fixed with neutral buffered formalin on the pelts for 24 hours, dissected, fixed, and then stained with Carmine as previously described for whole mount analysis (22). Routine hematoxylin-eosin staining was performed on the left #4 and #5 mammary gland of each animal followed by histopathological analysis.

**Statistical Analysis.** A Chi-square goodness-of-fit test was performed for segregation analysis of the three genotypic classes from heterozygous intercrosses. The overall difference in survival between  $Brca2^{\Delta27/\Delta27}$  and  $Brca2^{\Delta27/+}$  virgin females was compared with a life table test. Both a Peto analysis (23) and a Fisher's exact test were used to test for a difference in tumor rates between genotypic classes. Both procedures produced similar results.

## Results

### **Generation of mice with a homozygous germline deletion of *Brca2* exon 27.**

ES cells carrying a targeted *Brca2* allele with *loxP* sites flanking exon 27 were generated by homologous recombination (Figure 1). After transient Cre-expression *in vitro*, ES clones with a *Brca2*<sup>Δ27</sup> allele were identified. PCR products generated with the B2F1 and B2R2 primers that flank the 5' and 3' *loxP* sites (Figure 1) were sequenced to confirm the expected exon 27 deletion. Germline transmission of the *Brca2*<sup>Δ27</sup> allele was identified by standard breeding techniques.

As expected, reverse transcriptase-PCR (RT-PCR) analysis with primers specific for exon 27 does not yield detectable messages in testes RNA from *Brca2*<sup>Δ27/Δ27</sup> mice although this RT-PCR product is easily detectable for *Brca2*<sup>Δ27/+</sup> mice. Assuming a mutant transcript is expressed, it could give rise to a truncated protein product of 3142 amino acids compared to the wildtype murine *Brca2* protein that contains 3329 amino acids. Unfortunately, we are unable to confirm the presence or relative levels of this putative mutant *Brca2* protein due to the unavailability of specific antibodies directed against the murine gene product.

**Viability of *Brca2*<sup>Δ27/Δ27</sup> Mice.** Although the *Brca2*<sup>Δ27/Δ27</sup> animals are viable compared to previous *Brca2* germline mutants, survival analysis indicates an overall decrease in viability of homozygous mutants compared to heterozygous and wildtype littermates. First, cumulative genotyping at weaning of 278 pups from *Brca2*<sup>Δ27/+</sup> intercrosses reveals a significant deficit of *Brca2*<sup>Δ27/Δ27</sup> mice from the expected 1:2:1 Mendelian ratio (Table 1). When both sexes are combined, there are approximately 40% fewer *Brca2*<sup>Δ27/Δ27</sup> mice than expected, with both male and female offspring being

underrepresented. To further characterize the decreased overall viability of *Brca2*<sup>Δ27/Δ27</sup> mice during development, we examined embryonic fibroblasts from *Brca2*<sup>Δ27/+</sup> intercrosses at 13.5 days of gestation. Analysis of 39 such embryos show that the genotypic distribution does not deviate from the expected Mendelian ratio. Thus, a subset of *Brca2*<sup>Δ27/Δ27</sup> offspring appear to either die during late gestation or shortly after birth, suggesting that loss of *Brca2* function impacts overall viability. Secondly, the overall survival of *Brca2*<sup>Δ27/Δ27</sup> compared to *Brca2*<sup>Δ27/+</sup> virgin female mice is significantly decreased (p<0.05) by a life table test, providing additional support that lifetime survival is affected by this *Brca2* mutation. Interestingly, test matings of both adult *Brca2*<sup>Δ27/Δ27</sup> males and females with wildtype mice does not reveal apparent infertility or difficulty in raising litters.

**Inhibition of Mammary Side Branching in *Brca2*<sup>Δ27/Δ27</sup> Mice.** Alterations in normal growth and differentiation of mammary tissue from *Brca2*-mutant virgin females were determined using whole mount analysis. At six months of age, mammary tissue from three *Brca2*<sup>Δ27/Δ27</sup> animals exhibited a dramatic lack of side branching and a much lower density of ductules compared to that observed for three heterozygous and wildtype littermates, which were indistinguishable (Figure 2). Although the ducts reached the limits of the mammary fat pad in the homozygous mutant animals, a substantial lack of side branching was observed in these *Brca2*<sup>Δ27/Δ27</sup> females. These observations were confirmed by examining histological sections from these mice. This general trend of inhibited side branching observed in *Brca2*<sup>Δ27/Δ27</sup> females was maintained in the nine animals of all three genotypic classes that were examined subsequently at nine months of age.

### **Predisposition of *Brca2*<sup>Δ27/Δ27</sup> Mice to Spontaneous Tumor Development.**

*Brca2*<sup>Δ27/Δ27</sup> mice display an increased incidence of a wide variety of solid tumors compared to their *Brca2*<sup>Δ27/+</sup> and *Brca2*<sup>+/+</sup> littermates (Table 2). We observed untreated animals on a mixed 129 X C57BL/6N genetic background for tumor development or signs of morbidity. Prior to 17 months, 10 spontaneous tumors were detected in *Brca2*<sup>Δ27/Δ27</sup> mice while only a single tumor was observed in the *Brca2*<sup>Δ27/+</sup> animals and no tumors were observed in *Brca2*<sup>+/+</sup> animals during this time period.

Terminal sacrifices of the remaining animals were performed between 17 and 19 months of age. This enabled us to develop a comprehensive tumor spectrum for mice from each genotype (Table 2). With the combined data from all the moribund and terminal sacrifices, the *Brca2*<sup>Δ27/Δ27</sup> mice exhibited more than a two-fold increase in overall tumor incidence compared to their *Brca2*<sup>Δ27/+</sup> and *Brca2*<sup>+/+</sup> littermates. In 41 *Brca2*<sup>Δ27/Δ27</sup> mice, 30 tumors were observed, compared to only 11 tumors in 43 *Brca2*<sup>Δ27/+</sup> animals and 4 tumors in 15 *Brca2*<sup>+/+</sup> animals. The overall incidence of tumor-bearing mice for the *Brca2*<sup>Δ27/Δ27</sup> mice is 61% compared to a 26% and 20% incidence in *Brca2*<sup>Δ27/+</sup> and *Brca2*<sup>+/+</sup> littermates, respectively. These data from all mice combined show a highly significant difference ( $p < 0.01$ ) in the overall tumor rates between the *Brca2*<sup>Δ27/Δ27</sup> and *Brca2*<sup>Δ27/+</sup> animals. These results were also analyzed separately for virgin females alone, virgin plus multiparous females, and males only. The tumor response patterns and incidences for each of these smaller subgroups are similar to the tumor response of all animals combined. Statistically significant differences ( $p < 0.05$ ) in tumor incidences between the *Brca2*<sup>Δ27/Δ27</sup> and *Brca2*<sup>Δ27/+</sup> animals are observed when the data for each subgroup is considered independently. Because a smaller number of

*Brca2*<sup>+/+</sup> mice were examined, there was not enough statistical power to distinguish tumor rates between the wildtype and other genotypic classes.

The tumor spectrum is diverse and includes carcinomas, adenomas, lymphomas, and sarcomas (Table 2). Of particular interest is the exclusive appearance of various types of carcinomas in the *Brca2*<sup>Δ27/Δ27</sup> mice. These include one mammary adenosquamous carcinoma, five squamous cell carcinomas (three of gastric origin), two gastric carcinomas, one endometrial carcinoma, and two A/B lung carcinomas. Figure 3 illustrates representative histological sections for the two types of gastric tumors that were observed. Interestingly, a single mammary adenomyoepithelioma was detected in one *Brca2*<sup>Δ27/+</sup> mouse. The sarcoma incidence also appears to be increased in the *Brca2*<sup>Δ27/Δ27</sup> mice compared to their littermates. Three histiocytic sarcomas, along with a hemangiosarcoma and a leiomyosarcoma arose in *Brca2*<sup>Δ27/Δ27</sup> mice, while only two histiocytic sarcomas were identified in their *Brca2*<sup>Δ27/+</sup> and *Brca2*<sup>+/+</sup> littermates.

## Discussion

Here we describe germline *Brca2* mutant mice with a predisposition for tumor development. In contrast to previous reports of mice with homozygous germline mutations in the *Brca2* gene (6-8, 15-17), the *Brca2*<sup>Δ27/Δ27</sup> mice exhibit only a 40% decrease in expected viability during perinatal development. *Brca2*<sup>Δ27/Δ27</sup> mice of both sexes are fertile and lack gross developmental abnormalities. Mice harboring this germline mutation in the C-terminal domain of *Brca2* have an increased susceptibility for a wide spectrum of solid tumors. The fact that 10 of 11 spontaneous tumors that developed prior to 17 months arose in *Brca2*<sup>Δ27/Δ27</sup> mice indicates that not just the incidence but also the latency of tumor development is significantly affected by the presence of this *Brca2* mutation. Overall, the tumor spectrum we observed is similar to that reported for knockout mice eliminating the C-terminal region of the *Brca1* gene, where an increased incidence of a wide variety of carcinomas, sarcomas, and lymphomas was found (24). One unique finding of our study is the exclusive presence of carcinomas in *Brca2*<sup>Δ27/Δ27</sup> mice and specifically a substantial number of stomach cancers, both adenocarcinomas and squamous cell carcinomas. We have previously shown that *Brca2* expression in adult mouse tissues correlates with cell proliferation and is relatively high in the glandular mucosa of the stomach (25). Interestingly, stomach cancers are among the various tumor types that have been associated with BRCA2 mutations in humans, with a 2.59 relative risk (3).

This report supports a strong correlation between the *Brca2* mutation position and the resulting *Brca2* mouse knockout phenotype. We and other laboratories have shown previously that mice homozygous for targeted *Brca2* mutations 5' of the BRC repeats in

exon 11 exhibit early embryonic lethal phenotypes (6-8, 15-17). These BRC repeats interact with *Rad51* (12, 13) and have been highly conserved in evolution (18, 26) which suggests that they are important functional domains of the *Brca2* protein. A few viable *Brca2*-mutant mice have been generated that retain at least some of these BRC repeats and these animals display multiple severe developmental abnormalities, infertility, and early thymic lymphoma development (7, 8). The *Brca2*<sup>Δ27/Δ27</sup> mice lack only the carboxy terminal domain and could produce a truncated *Brca2* gene product that preserves all eight BRC repeats. In contrast to all other *Brca2*-null mice reported to date, these *Brca2*<sup>Δ27/Δ27</sup> mice display a modest loss of viability and have no gross developmental abnormalities or obvious infertility. Thus, full retention of the BRC repeats and other functional domains may direct a genotype-phenotype correlation.

This study extends previous findings by several laboratories that have demonstrated the functional significance of the C-terminal domain of both human and rodent BRCA2. Morimitsu and coworkers (10) demonstrated that mouse embryonic stem cells and embryonic fibroblasts lacking exon 27 are hypersensitive to  $\gamma$ -radiation and undergo premature senescence. Recent reports indicate that the C-terminus of *Brca2* is required for error-free homology-directed repair of DNA double strand breaks and the ability to facilitate the induction of *Rad51* nuclear foci after ionizing radiation (20,21). Thus, disruption of the exon 27 *Brca2*-*Rad51* interaction appears to lead to defective repair of DNA damage and generalized chromosomal instability with a subsequent increased risk of neoplastic progression in *Brca2*-deficient cells (4,5). The human C-terminal region of BRCA2 also appears to be critical because a truncating mutation (9808delCC) at position 3195, which occurs just upstream of the predicted *Rad51*-

interacting domain in human BRCA2 exon 27, is associated with an elevated breast cancer risk (27).

Despite the increased susceptibility of *Brca2*<sup>Δ27/Δ27</sup> mice to tumorigenesis, these animals are not highly susceptible to mammary tumorigenesis. Several factors may account for this observation but the most likely reason is the fact that the *Brca2*<sup>Δ27</sup> mutation was examined on a mixed C57BL/6N and 129 genetic background. C57BL/6N and 129/SvEvS6 mice are both extremely resistant to spontaneous, as well as radiation-induced mammary carcinogenesis (MB *et al.*, manuscript in preparation<sup>7</sup>). Thus, we are currently using microsatellite marker-assisted breeding techniques to transfer this *Brca2*<sup>Δ27</sup> mutation onto inbred strains such as BALB/cJ that are susceptible to mammary carcinogenesis.

The reduced ductal branching phenotype seen in *Brca2*<sup>Δ27/Δ27</sup> virgin female mice may be associated with increased mammary tumor risk in combination with other environmental or genetic interactions. We can not exclude the possibility that the subtle mammary gland phenotype we have observed may be due to hormonal differences in the *Brca2*<sup>Δ27/Δ27</sup> mice compared to their littermates rather than a more direct *Brca2* effect. However, Xu and coworkers described a blunted ductal branching phenotype in the mammary glands of mice with a mammary-specific targeted *Brca1* mutation that was associated with subsequent tumor development after a long latency (14, 28). In addition, a high incidence of mammary adenocarcinomas was reported recently in mice carrying a mammary tissue-specific mutation that completely disrupts the *Brca2* gene (29). Given their substantial viability and a cancer predisposition, *Brca2*<sup>Δ27/Δ27</sup> mice and cells derived from them will be useful to further define the role of *Brca2* in tumorigenesis.

## Acknowledgements

We thank Drs. Cynthia Afshari and Richard DiAugustine for the critical review of this manuscript. The expert technical assistance of William Gersch, Brian Register, Sarah Hagevik, Christine Furmick, Laura Wharey, and David Godley is greatly appreciated. We would like to thank Dr. John Seely for his pathology support. We also thank the staff and managers of Integrated Laboratory Systems, Inc. for their substantial animal husbandry, necropsy and histology support. This research was funded in part by Department of Defense Breast Cancer Research Grant DAMD17-98-1-8131 to KM.

## Footnote (Page 13)

<sup>7</sup> L. Michelle Bennett, Jason Malphurs, Toni Ward, John C. Seely, Barbara J. Davis, and Roger W. Wiseman. Radiation-induced mammary carcinogenesis and ductal morphology in inbred mouse strains. Manuscript in preparation.

## References

1. Wooster, R., Bignell, G., Lancaster, J.M., Swift, S., Seal, S., Mangion, J., Collins, N., Gregory, S., Gumbs, C., Micklem, G., Barfoot, R., Hmoudi, R., Patel, S., Rice, C., Biggs, P., Hashim, Y., Smith, A., Conner, F., Arason, A., Gudmundsson, J., Ficenc, D., Kelsell, D., Ford, D., Tonin, P., Bishop, D.T., Spurr, N.K., Ponder, B.A.J., Eeles, R., Peto, J., Devilee, P., Cornelisse, D., Lynch, H., Narod, S., Lenoir, G., Egilsson, V., Barkadotir, R.B., Easton, D.F., Bentley, D.R., Futreal, P.A., Ashworth, A., and Stratton, M.R. Identification of the breast cancer susceptibility gene BRCA2. *Nature (Lond.)* 378: 789-792, 1995.
2. Easton, D. Breast cancer genes-what are the real risks? *Nat. Gen.* 16: 210-211, 1997.
3. The Breast Cancer Linkage Consortium. Cancer Risks in BRCA2 Mutation Carriers. *J. Nat. Cancer Inst.* 91 (15): 1310-1316, 1999.
4. Welsh, P.L., Owens, K.N., and King, M.-C. Insights into the functions of BRCA1 and BRCA2. *Trends in Genetics* 16: 69-74, 2000.
5. Chen, J.J., Silver, D., Cantor, S., Livingston, D.M., and Scully, R. BRCA1, BRCA2, and Rad51 operate in a common DNA damage response pathway. *Cancer Res.* 59: 1752S-1756S, Supplement S, 1999.
6. Sharan, S.K., Morimatsu, M., Albrecht, U., Lim, D-S., Regel, E., Sands, A., Eichele, G., Hasty, P., and Bradley, A. Embryonic lethality and radiation hypersensitivity mediated by rad51 in mice lacking Brca2. *Nature (Lond.)* 386: 804-810, 1997.
7. Connor, F., Bertwistle, D., Mee, P.J., Ross, G.M., Swift, S., Grigorieva, E., Tybulewicz, V.L.J., and Ashworth, A. Tumorigenesis and a DNA repair defect in mice with a truncating Brca2 mutation. *Nat. Gen.* 17: 423-430, 1997.

8. Friedman, L.S., Thistlethwaite, F.C., Patel, K.J., Yu, V.P.C.C., Lee, H., Venkitaraman, A.R., Abel, K. J., Carlton, M. B.L., Hunter, S.M., Colledge, W.H., Evans, M.J., and Ponder, B.A.J. Thymic lymphomas in mice with a truncating mutation in Brca2. *Cancer Res.* 58:1338-1343, 1998.
9. Patel, K.J., Yu, V.P.C.C., Lee, H., Corcoran, A., Thistlethwaite, F.C., Evans, M.J., Colledge, W.H., Friedman, L.S., Ponder, B.A.J., and Venkitaraman, A.R. Involvement of Brca2 in DNA repair. *Molecular Cell* 1:347-357, 1998.
10. Morimatsu, M., Donoho, G., and Hasty, P. Cells deleted for Brca2 COOH terminus exhibit hypersensitivity to Y-radiation and premature senescence. *Cancer Res.* 58: 3441-3447, 1998.
11. Mizuta, R., LaSalle, J.M., Cheng, H.-L., Shinohara, A., Ogawa, H., Copeland, N., Jenkins, N.A., Lalande, M., and Alt, F.W. RAB22 and RAB163/mouse BRCA2: proteins that specifically interact with the RAD51 protein. *Proc. Natl. Acad. Sci. USA* 94: 6927-6932, 1997.
12. Wong, A.K.C., Pero, R., Ormonde, P.A., Tavtigian, S.V., Bartel, P.L. RAD51 interacts with the evolutionarily conserved BRC motifs in the human breast cancer susceptibility gene Brca2. *J. Biol. Chem.* 272: 31941-31944, 1997.
13. Chen, P.L., Chen, C.F., Chen, Y., Xiao, J., Sharp, Z.D., and Lee, W.H. The BRC repeats in BRCA2 are critical for RAD51 binding and resistance to methyl methanesulfonate treatment. *Proc. Natl. Acad. Sci. USA* 95: 5287-5292, 1998.
14. Deng, C.-X. and Brodie, S.G. Knockout mouse models and mammary carcinogenesis. *Seminars in Cancer Biology* 11:387-394, 2001.

15. Suzuki, A. de la Pompa, J.L., Hakem, R., Elia, A., Yoshida, R., Mo, R., Nishina, H., Chuang, T., Wakeham, A., Itie, A., Koo, W., Billia, P., Ho, A., Fukumoto, M., Hui, C.C., and Mak, T.W. *Brca2* is required for embryonic cellular proliferation in the mouse. *Genes Dev.* 11:1242-1252, 1997.
16. Ludwig, T., Chapman, D.L., Papaioannou, V.E., and Efstratiadis, A. Targeted mutations of breast cancer susceptibility gene homologs in mice: lethal phenotypes of *Brca1*, *Brca2*, *Brca1/Brca2*, *Brca1/p53*, and *Brca2/p53* nullizygous embryos. *Genes Dev.* 11:1226-1241, 1997.
17. Bennett, L.M., McAllister, K.A., Blackshear, P.E., Malphurs, J., Goulding, G., Collins, N.K., Ward, T., Bunch, D.O., Eddy, E.M., Davis, B.J., and Wiseman, R.W. *Brca2*-null embryonic survival is prolonged on the BALB/c genetic background. *Molecular Carcinogenesis* 28: 174-183, 2000.
18. McAllister, K.A., Haugen-Strano, A., Hagevik, S., Brownlee, H.A., Collins, N.K., Futreal, P.A., Bennett, L.M., and Wiseman, R.W. Characterization of the rat and mouse homologues of the BRCA2 breast cancer susceptibility gene. *Cancer Res.* 57: 3121-3125, 1997.
19. Spain, B.H., Larson, C.J., Shihabuddin, L.S., Gage, F.H., and Verma, I.M. Truncated BRCA2 is cytoplasmic: implications for cancer-linked mutations. *Proc. Natl. Acad. Sci. USA* 96(24): 13920-13925, 1999.
20. Moynahan, M.J., Pierce, A.J., and Jasin, M. BRCA2 is required for homology-directed repair of chromosomal breaks. *Molecular Cell* 7: 263-272, 2001.
21. Tutt, A., Bertwistle, D., Valentine, J., Gabriel, A., Swift, S., Ross, G., Griffin, C., Thacker, J., and Ashworth, A. Mutation in *Brca2* stimulates error-prone homology-

- directed repair of DNA double-strand breaks occurring between repeated sequences. The EMBO J. 20: 4704-4716, 2001.
22. Banerjee, M.R., Wood, B.G., Lin, F.K., and Crump, L.R. Organ culture of the whole mammary gland of the mouse. Tissue Culture Association Manual 2:457-461, 1976.
  23. Peto, R., Pike, M.C., Day, N.E., Gray, R.G., Lee, P.N., Parish, S., Peto, J., Richards, S., and Wahrendorf, J. Guidelines for simple, sensitive, significance tests for carcinogenic effects in long-term animal experiments. In: IARC long-term and short-term screening assays for carcinogens: critical appraisal, supplement 2. International Agency for Research on Cancer, Lyon, France, p. 311-426, 1980.
  24. Ludwig, T., Fisher, P., Ganesan, S., and Efstratiadis, A. Tumorigenesis in mice carrying a truncating *Brcal* mutation. Genes Dev. 15:1188-1193, 2001.
  25. Blackshear, P., Goldsworthy, S., Foley, J., McAllister, K., Bennett, L.M., Collins, N.K., Bunch, D., Brown, P., Wiseman, R.W., and Davis, B.J. *Brcal* and *Brcal2* expression patterns in mitotic and meiotic cells in mice. Oncogene 16: 61-68, 1998.
  26. Bignell, G. Micklem G., Stratton, M.R., Ashworth, A. Wooster, R. The BRC repeats are conserved in mammalian BRCA2 proteins. Hum. Mol. Genet. 6:53-58, 1997.
  27. Hakansson, S., Johannsson, O., Johansson, U., Selberg, G., Loman, N., Gerdes, A-M., Holmberg, E., Dahl, N., Pandis, N., Kristoffersson, U., Olsson, H., and Borg, A. Moderate frequency of BRCA1 and BRCA2 germline mutations in Scandinavian familial breast cancer. Am. J. Hum. Genet. 60:1068-1078, 1997.
  28. Xu, X., Wagner, K.-U., Larson, D., Weaver, Z., Li, C., Ried, T., Hennighausen, L., Wynshaw-Boris, A., and Deng, C.-X. Conditional mutant of *Brcal* in mammary

epithelial cells results in blunted ductal morphogenesis and tumour formation. *Nat. Gen.* 22: 37-42, 1999.

29. Ludwig, T., Fisher, P., Vundavalli, M., and Efstratiadis, A. Development of mammary adenocarcinomas by tissue-specific knockout of *Brca2* in mice. *Oncogene* 20: 3937-3948, 2001.

## Figure Legends

Figure 1. Generation of *Brca2*<sup>Flox27</sup> and *Brca2*<sup>Δ27</sup> ES cells. Homologous recombination between the endogenous *Brca2* locus (*Brca2*<sup>Wildtype</sup>) and a targeting vector carrying a pair of *LoxP* sites flanking *Brca2* exon 27 and a neomycin resistance cassette yielded a “floxed” *Brca2* locus (*Brca2*<sup>Flox27</sup>). ES cells containing the properly targeted *Brca2*<sup>Flox27</sup> allele were isolated by positive/negative selection and confirmed by Southern blot and PCR analyses. Conversion of the *Brca2*<sup>Flox27</sup> allele to the *Brca2*<sup>Δ27</sup> allele was accomplished *in vitro* by transient electroporation of *Brca2*<sup>Flox27</sup> ES cells with a Cre-expression plasmid. The Cre recombinase induces site-specific recombination between the 5' and 3' *loxP* sites resulting in the deletion of exon 27 and the neomycin gene. Germline transmission of the desired *Brca2*<sup>Δ27</sup> allele was obtained by injection into blastocysts followed by standard breeding techniques.

Figure 2. Altered mammary ductal morphology in *Brca2*<sup>Δ27/Δ27</sup> mice. Representative mammary gland whole mounts stained with Carmine are illustrated from six-month-old virgin female mice. A. *Brca2*<sup>Δ27/+</sup> mammary gland. B. *Brca2*<sup>Δ27/Δ27</sup> mammary gland. Ductal side branching is clearly reduced in *Brca2*<sup>Δ27/Δ27</sup> mammary tissue compared to *Brca2*<sup>Δ27/+</sup> littermates.

Figure 3. Photomicrographs of gastric carcinomas in *Brca2* homozygous mutant mice. A. Gastric squamous cell carcinoma invading into the muscular layer (arrows). Cords and nests of polyhedral squamous cells filled with keratinized debris and inflammatory cells characterize the tumor. B. Gastric adenocarcinoma invading into the muscular layer

(arrows). This tumor is characterized by tubules and acini of cuboidal neoplastic cells and in many areas the cells have lost their usual orientation.

Table 1 Segregation analysis of offspring from *Brca2*<sup>Δ27/+</sup> intercross mice

Genotype	<i>Brca2</i> <sup>Δ27/Δ27</sup>	<i>Brca2</i> <sup>Δ27/+</sup>	<i>Brca2</i> <sup>+/+</sup>	<i>p</i> Value
Females	37	88	25	0.04
Males	40	66	22	0.08
Combined	77	154	47	0.008

Table 2. Spectrum of Spontaneous Tumor Development in *Brca2*-Deficient Mice

	<u><i>Brca2</i> -/-</u>	<u><i>Brca2</i> +/-</u>	<u><i>Brca2</i> +/+</u>
<b>Virgin Females:</b>	<b>25 total mice</b>	<b>30 total mice</b>	<b>11 total mice</b>
<u>Carcinomas:</u>			
Mammary adenosquamous carcinoma	1		
Gastric carcinoma	1		
Gastric squamous cell carcinoma	1		
Endometrial carcinoma	1		
A/B lung carcinoma	1		
<u>Sarcomas:</u>			
Histiocytic	3	2	
Hemangiosarcoma	1		
<u>Lymphomas:</u>			
Mediastinal	5		1
Nodal	1	4	2
<u>Adenomas:</u>			
Pituitary adenoma	1	1	
Mammary adenomyoepithelioma		1	
A/B lung adenoma			1
Ovarian cystadenoma	1		
Adrenal cortical adenoma		1	
	17 tumors in 14 mice	9 tumors in 9 mice	4 tumors in 3 mice
<b>Multiparous Females:</b>	<b>7 total mice</b>	<b>1 mouse</b>	<b>0 mice</b>
<u>Carcinomas:</u>			
Gastric squamous cell carcinoma	2		
Gastric carcinoma	1		
<u>Lymphomas:</u>			
Mediastinal	2		
	5 tumors in 5 mice	0 tumors	0 tumors
<b>Males:</b>	<b>9 total mice</b>	<b>12 total mice</b>	<b>4 total mice</b>
<u>Carcinomas:</u>			
Squamous cell carcinomas	2		
A/B lung carcinoma	1		
<u>Sarcomas:</u>			
Leiomyosarcoma	1		
<u>Lymphomas:</u>			
Mediastinal	1	1	
Nodal		1	
<u>Adenomas:</u>			
Adrenal cortical adenomas	2		
Hepatic adenoma	1		
	8 tumors in 6 mice	2 tumors in 2 mice	0 tumors

**Brca2**<sup>Wildtype</sup>

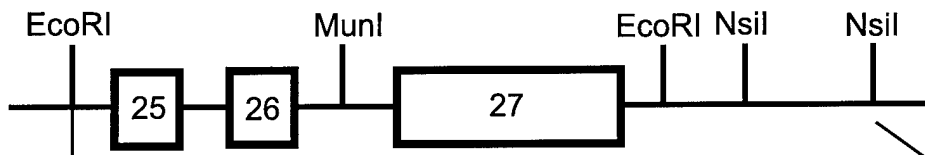

**Brca2**<sup>Flox27</sup>

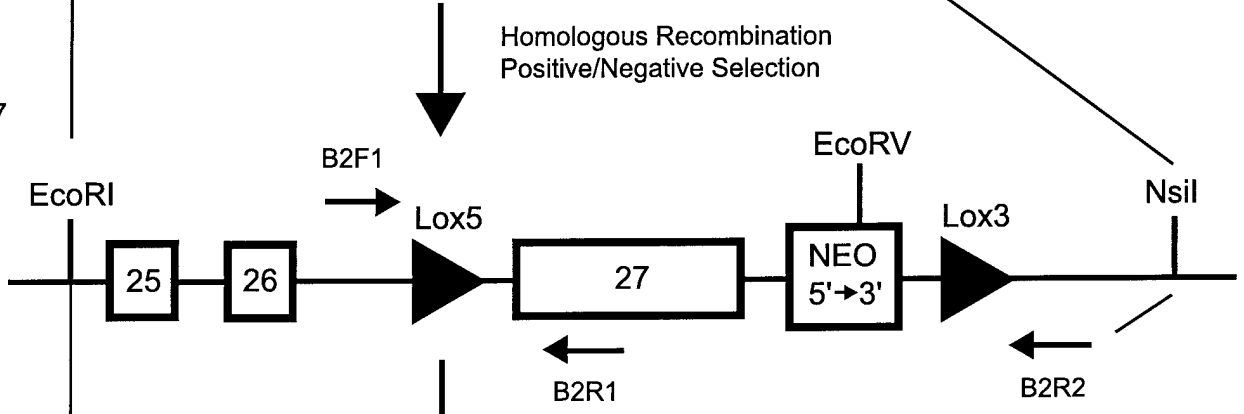

**Brca2**<sup>Δ27</sup>

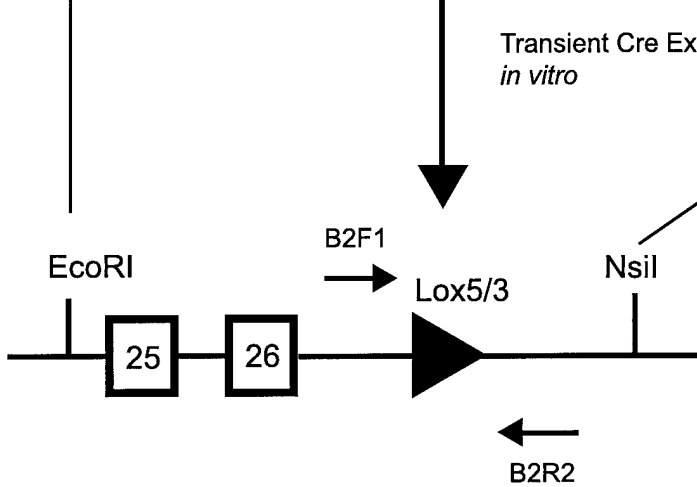



**Fig. 3A**

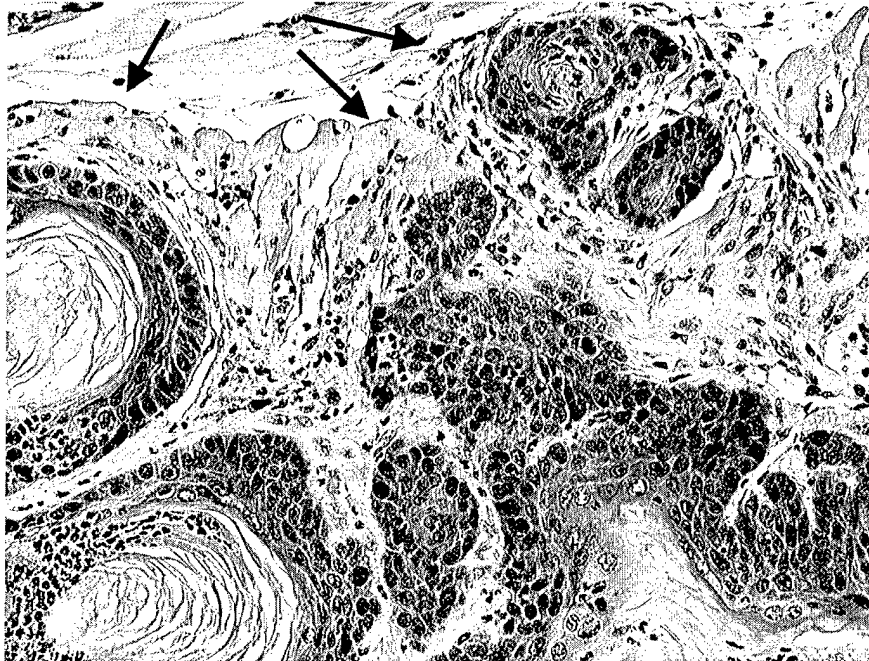

**Fig. 3B**

