

REPORT DOCUMENTATION PAGE

Form Approved
OMB No. 0704-0188

Public reporting burden for this collection of information is estimated to average 1 hour per response, including the time for reviewing instructions, searching existing data sources, gathering and maintaining the data needed, and completing and reviewing this collection of information. Send comments regarding this burden estimate or any other aspect of this collection of information, including suggestions for reducing this burden to Department of Defense, Washington Headquarters Services, Directorate for Information Operations and Reports (0704-0188), 1215 Jefferson Davis Highway, Suite 1204, Arlington, VA 22202-4302. Respondents should be aware that notwithstanding any other provision of law, no person shall be subject to any penalty for failing to comply with a collection of information if it does not display a currently valid OMB control number. PLEASE DO NOT RETURN YOUR FORM TO THE ABOVE ADDRESS.

1. REPORT DATE (DD-MM-YYYY)	2. REPORT TYPE Technical Papers	3. DATES COVERED (From - To)
------------------------------------	---	-------------------------------------

4. TITLE AND SUBTITLE	5a. CONTRACT NUMBER
	5b. GRANT NUMBER
	5c. PROGRAM ELEMENT NUMBER

6. AUTHOR(S)	5d. PROJECT NUMBER
	5e. TASK NUMBER
	5f. WORK UNIT NUMBER

20020823 060

7. PERFORMING ORGANIZATION NAME(S) AND ADDRESS(ES) Air Force Research Laboratory (AFMC) AFRL/PRS 5 Pollux Drive Edwards AFB CA 93524-7048	8. PERFORMING ORGANIZATION REPORT
--	--

9. SPONSORING / MONITORING AGENCY NAME(S) AND ADDRESS(ES) Air Force Research Laboratory (AFMC) AFRL/PRS 5 Pollux Drive Edwards AFB CA 93524-7048	10. SPONSOR/MONITOR'S ACRONYM(S)
	11. SPONSOR/MONITOR'S NUMBER(S)

12. DISTRIBUTION / AVAILABILITY STATEMENT

Approved for public release; distribution unlimited.

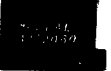

DTS ✓

6340 PR 65

FILE

MEMORANDUM FOR PRS (In-House Publication)

FROM: PROI (STINFO)

11 Jan 2001

SUBJECT: Authorization for Release of Technical Information, Control Number: AFRL-PR-ED-TP-2001-009
Bromaghim, D.R., et. al., "Solar Cell Degradation During the 26kW Electric Propulsion Space Experiment (ESEX) Flight"

Paper for the Journal of Propulsion and Power
(Deadline: N/A)

(Statement A)

15. SUBJECT TERMS

16. SECURITY CLASSIFICATION OF:			17. LIMITATION OF ABSTRACT	18. NUMBER OF PAGES	19a. NAME OF RESPONSIBLE PERSON Leilani Richardson
a. REPORT Unclassified	b. ABSTRACT Unclassified	c. THIS PAGE Unclassified			19b. TELEPHONE NUMBER (include area code) (661) 275-5015

41 items enclosed

*Past or present tense
I prefer past*

Solar Cell Degradation during the 26-kW Electric Propulsion Space Experiment

(ESEX) Flight

J.H. Schilling*, G.G. Spanjers†, D.R. Bromaghim‡

Propulsion Directorate, AFRL/PRSS, Air Force Research Laboratory, Edwards AFB, CA 93524

L.K. Johnson,§ The Aerospace Corporation, 2350 E. El Segundo Blvd., El Segundo, CA 90245

Abstract

The United States Air Force Research Laboratory's Electric Propulsion Space Experiment (ESEX) was launched and operated in early 1999 in order to demonstrate the compatibility and readiness of a 30-kW class ammonia arcjet for satellite propulsion applications. As part of this flight, an array of on-board contamination sensors was used to assess the effect of the arcjet and other environments on the spacecraft. The sensors consisted of microbalances to measure material deposition, radiometers to assess material degradation due to thermal radiation, and solar cell segments to investigate solar array degradation. During firings, the solar cell segments show decreasing open-circuit voltage, probably attributable to an additional electrical load provided by a short through the plume plasma. Over eight firings of the ESEX arcjet, and 33 minutes, 26 seconds operating time, the solar cells also exhibit a 3% decrease in short-circuit current, attributable to decreased solar transmission of the cover glass. However, no effects associated with the arcjet are observed on the spacecraft solar arrays. In general, the contamination effects are observed only on the solar cells sensor segments placed very near the thruster exhaust nozzle. In the backplane of the thruster, where the main arrays are located, no deleterious effects are

* Project Engineer, Sparta Inc., Air Force Research Laboratory, Edwards AFB, CA, Member AIAA;
Present address: W.E. Research, 4360 San Juan Court, Rosamond, CA, 93560

† Project Scientist, Member AIAA

‡ ESEX Program Manager, Member AIAA

§ ESEX Chief Scientist, Present address: Jet Propulsion Laboratory, MS 125-109, 4800 Oak Grove Dr., Pasadena, CA 91109

observed, indicating that while engineering measures may be required for equipment in the immediate vicinity of the thruster, the arcjet environment is generally benign.

I. Introduction

Operation of thermal control and optical surfaces can be impaired by material deposition on spacecraft surfaces. Excessive heat flux can degrade the emissive and absorptive properties of spacecraft materials changing the thermal balance of the satellite. Solar cell operation can be degraded by the presence of a conductive plasma exhaust. Understanding the coupling of these effects with high-power electric propulsion is of critical importance to the development of the next-generation of large United Space Air Force (USAF) space structures. A major goal of the USAF Electric Propulsion Space Experiment (ESEX)¹ is to explore these issues by measuring the contamination effects of a 30-kW class arcjet in flight. ESEX was launched on 23 February 1999 as 1 of 9 experiments aboard the USAF's Advanced Research and Global Observation Satellite (ARGOS)².

An array of sensors is positioned at strategic locations ^{on?} of the ESEX package in order to assess the contamination effects. A sample Gallium Arsenide (GaAs) solar array segment placed near the arcjet nozzle is used to investigate impact on the satellite power generation capability. Thermal surface degradation due to the arcjet firing is measured using four radiometers.³ Mass deposition is measured using four thermoelectric quartz crystal microbalances (TQCMs).⁴ Electromagnetic interference is characterized using a set of on-board antennas and ground stations.⁵ This paper focuses on arcjet interference and degradation of the solar array segment. Measurements from the other on-board sensors can be found in companion papers within this issue.

During ^{eight} 8 firings of the ESEX arcjet, solar cell segments placed ^d near the thruster exhaust show increasing degradation through the experiment, attributable to the exhaust plasma partially

shorting the solar cell load. The solar array measurements also show a 3% decrease in power generation over the eight arcjet firings, attributable to degradation in solar transmission through the cover glass material. No contamination effects associated with the arcjet firing are observed on the main ARGOS solar arrays.

The solar array measurements indicate the need for proper engineering in the design of spacecraft using high power arcjets. Degradation associated with contamination is observed on solar array segments places very near, and with a direct view of the exhaust nozzle of the thruster. It is, however, highly unlikely that material or sensors would be located this close to the thrusters exit plane in an operational high-power electric-propulsion system. The main ARGOS solar arrays, located in the backplane of the arcjet, show no deleterious effects. For future programs, while engineering measures may be needed for spacecraft equipment in the immediate vicinity of the thruster body, the arcjet environment is generally benign.

plural or singular? →

II. Solar Array Segment Sensors

The ESEX flight unit is equipped with 4 microbalances, 4 Radiometers, and 2 sections of GaAs solar array cells. The sensors are positioned on the ESEX flight unit as shown in Fig. 1. The solar array cells are positioned 43 cm from the arcjet exhaust plane, 3 degrees from horizontal, relative to the thruster exit plane and downstream of the exhaust, and with a sensor angle of 42 degrees if the sensor normal relative to the thruster exit.

spell out

is?

Possible effects of arcjet operation on solar array performance is a matter of understandable concern. To address this issue, two small solar array segments are mounted on top of the ESEX diagnostic tower as shown in Fig. 2. Each segment consists of four 2-cm by 4-cm gallium arsenide cells in series, with each cell under a .006-inch thick cerium-doped borosilicate cover glass. This cover glass overhangs the edge of the cells by 0.2 mm, but the interconnects between

cells in an array are exposed for a length of approximately 0.8 mm. The arrays are mounted at a 42-degree angle to allow direct exposure to both incident sunlight and to the arcjet body and plume. One solar array is connected to an open-circuit voltage sensor, the other to a short-circuit current sensor, allowing independent measurement of both parameters. A thermocouple is mounted to the base of the solar array assembly to monitor solar array temperature with an accuracy of $\pm 1^\circ\text{C}$.

Under direct solar illumination and at temperatures expected for on-orbit operation, the GaAs solar cell arrays produce a current of approximately 212 mA and a voltage of approximately 4.5

V. Unfortunately, the sensing circuit for the open-circuit voltage cannot read values greater than 4.2 (volts), so the data is truncated at that value during periods of direct solar illumination.

Please be consistent throughout paper

III. Flight Data

The ARGOS host spacecraft for ESEX was launched 23 February 1999 from Vadenberg AFB, using a Delta II launcher into a 97-degree, near-polar orbit at 846-km altitude. The ESEX contamination diagnostics were powered to receive data 1 hour, 25 minutes after launch. A total of ^{eight} ESEX firings were performed between 15 March 1999 and 21 April 1999. Following the ^{eight} firing, a battery anomaly occurred which precluded additional firings. The ESEX events, including the battery anomaly are described in detail in Ref. 1. A summary of the ESEX events related to the contamination measurements is shown in Table 1.

Figure 3
?

Figure 4 shows the solar cell voltage and current during the six primary arcjet firings. The current rises above zero about two minutes after arcjet start, reaching a nearly constant value in an additional two minutes, and dropping rapidly to zero after arcjet shutdown. This is consistent with illumination of the solar cells by the glowing arcjet body. Solar cell voltage also follows the same general pattern during the three firings which occurred during eclipse (on days 80, 85, and

90), with the voltage rise occurring slightly earlier, and the post-shutdown drop-off substantially slower, than is observed for the current. Although not apparent in the scale used in Fig. 4, voltage is also observed to drop off very slightly during the near-equilibrium phase of the longer firings, which is expected as the solar cell temperatures increase.

Fig 3 (?)

Two other effects are observed during the arcjet firings. During the firings on days 80 and 85, there is a small voltage spike 20 seconds after ignition peaking at about 1 Volt. Also, immediately after shutdown in all six firings, there is a small instantaneous jump in voltage, after which the voltage trails off as the arcjet cools. The magnitude of this jump increases from approximately 0.2 volts after the first firing to 0.6 volts after the last in the sequence.

Slightly different behavior is seen on the ^{three} firings that occurred while the solar cells ^{were} exposed to indirect sunlight – the spacecraft being in sun, but the solar cells shadowed by the arcjet heat shield and/or the ESEX package deck. In this geometry, the solar cells receive enough illumination due to sunlight scattered or reflected from other components of the spacecraft to maintain a steady-state open circuit voltage of 2-3 volts, but no measurable current. The ~~Day 82~~ firing occurred less than two minutes after the solar cells went into shadow. Solar cell current during these firings followed the same pattern as with the eclipse firings. So ^{too} ~~to~~ did solar cell voltage after the first two minutes of the firing, with the obvious exception of falling off to the original steady-state voltage due to indirect illumination, ~~(rather than to zero)~~ after shutdown. The instantaneous post-shutdown jump is observed in these firings, again increasing in magnitude with each successive firing.

on day 82
to be
consistent
w/ previous
#).

The substantial difference between the indirect-illumination firings and the eclipse firings is in the behavior of the solar cell voltage during the first two minutes. In all three cases, the voltage begins to fall off from the original steady-state value about forty seconds into the firing, and

drops precipitously at about sixty seconds. Voltage recovers equally rapidly about ten to twenty seconds later, shortly before the current rise and at approximately the ^{same} time the voltage is observed to rise from zero in the eclipse firings. Both the magnitude and duration of the voltage transient increase in successive firings.

In light of the observed effect of arcjet operation on solar cell voltage, it may be instructive to examine the (V-I) curve for the solar cells with the arcjet in both on and off states. The illumination of the solar cells by the incandescent arcjet body, which continues for some time following arcjet shutdown, offers an opportunity for such a comparison ^o and Figure (5) shows voltage (vs.) current data for all six full-length arcjet firings. With the arcjet shut down, the data falls on a single curve, and even very small currents correlate with open-circuit voltages in excess of 3 volts. When the arcjet is operating, however, the (V-I) curve is shifted down in voltage from the arcjet-off case, with the magnitude increasing at each firing. The shift is most pronounced for low current values, and much less significant at currents of 10 mA or greater. This is consistent with the observed voltage jump following arcjet cutoff, and may help explain the voltage drop at ~~sixty~~ ⁶⁰ seconds after ignition in the partial-illumination cases.

Long-term degradation of the solar cells is shown in Fig. (6) ^{5?} where the solar cell current is plotted over several days at three sample times during the flight; before the arcjet is fired, after the arcjet ^{is} firings, and after the battery anomaly. Prior to the arcjet firings a solar cell current of about 214 mA is observed. After the eight firings the current drops to about 207 mA. Following the battery anomaly a smaller decrease to about 205 mA is observed. This indicates that during the arcjet firings a 3% decrease in solar cell current and power occurs. The source of this decrease is likely a decrease in the solar transmissivity of the solar cell cover glass. No degradation of the main ARGOS arrays was reported as a result of the ESEX arcjet firings.

IV - bold

Discussion

The observed reduction in the solar cell voltage during arcjet operation is believed to be a result of the plasma forming an alternate, shorting current path. The exposed interconnects between solar cells provide an obvious attachment point for an external glow discharge across the cell face, once arcjet operation has established a sufficient plasma density in the vicinity of the array.

Such a short would be limited in current by the finite density of charge carriers in the plasma. At low power levels early in the arcjet start sequence, plasma density seems to be inadequate to short a significant fraction of the solar array current. As the arcjet reaches full power, the plasma density increases to the point where most or all of the array current is drawn through the short~~x~~ (rather than the voltage transducer~~x~~) resulting in the observed voltage drop. Finally, as the arcjet reaches thermal equilibrium, radiation from the incandescent arcjet body drives enough current in the array to saturate the plasma short and restore normal array operation with only a very minor current loss and voltage reduction. These three phases of operation correspond with the observed voltage loss and subsequent recovery during arcjet start. The small voltage jump immediately following shutdown results from the elimination of the plasma short, forcing that fraction of the array current to the voltage transducer.

To

These effects are observed to increase with successive firings, possibly due~~/~~erosion or sputtering of the exposed interconnects increasing the effective area of the plasma current connection site. This effect is limited to low-current operation of the solar array in the immediate vicinity of the arcjet plume, which should not occur in a full-scale flight design. The main ARGOS solar arrays, well in the backfield of the arcjet, reported no degradation of power during arcjet firings. This indicates that the problem can be alleviated through appropriate spacecraft design.

V. *bold*

Summary and Conclusions

A preliminary analysis of the data from the ESEX flight is performed to assess the contamination associated with the use of the 30-kW arcjet. Solar cell segments show a decrease in output voltage when the arcjet is fired, which is most prevalent during periods of low-current operation. This effect is believed to result from impingement of the arcjet plasma on the solar arrays, producing a current-limited short circuit between exposed interconnects in the array assembly. This deleterious effect can be controlled through the judicious placement of the thruster relative to the solar arrays, or by avoiding exposed and uninsulated electrical interconnects in array design. The solar array segment also shows a 3% decrease in current following the ^{eight} arcjet firings, presumably a result of decreased solar transmission through the cover glass.

as per a discussion with Dr Spangier, this will be modified

In general, deleterious contamination effects were observed only for sensors placed very near the arcjet nozzle – much closer than would be designed on an operational spacecraft. Sensors showed no contamination effects in the thruster backplane. The ESEX data suggest that the contamination associated with the operation of high-power electric propulsion can be controlled through relatively simple design adjustments.

VI. Acknowledgements

The authors would like to extend their gratitude for the expert technical contributions of Mary Kriebel, Don Baxter, Bob Tobias, David Lee, David Huang, and N. John Stevens of TRW in the design and development of the flight diagnostic package. We also acknowledge the ARGOS program office and the flight operations team at Kirtland AFB for their technical expertise, as well as their insight and flexibility in the mission operations.

Need to be capitalized?

VII. References

Last name 1st ¹ D.R. Bromaghim, et al., "An Overview of the On-Orbit Results from the ESEX Flight Experiment," AIAA paper 99-2706, June 1999. Also submitted to this issue, J. Prop and Power. *write out to be consistent i other references*

² B.J. Turner, and F.J. Agardy, "The Advanced Research and Global Observation Satellite (ARGOS) Program," AIAA paper 94-4580, Sept. 1994.

³ Spanjers, G. G., Schilling, J. H., Bromaghim, D. B., Johnson, L. K., "Radiometric Analysis from the ESEX 26 kW Ammonia Arcjet Flight Experiment," submitted to this issue, Journal of Propulsion and Power.

⁴ Spanjers, G. G., Schilling, J. H., Bromaghim, D. B., Johnson, L. K., "Mass Deposition Measurements from the ESEX 26 kW Ammonia Arcjet Flight Experiment," submitted to this issue, Journal of Propulsion and Power.

⁵ Dulligan, M. J., Bromaghim, D. B., Zimmerman, J. A., Hardesty, D., Johnson, L. K., "Observations of the Effect on Spacecraft Function and Communications by the ESEX 26kW Ammonia Arcjet Operation," submitted to this issue, Journal of Propulsion and Power.

Table 1: Contamination Events during ESEX Flight Experiment

Firing (F) or Event	Date/Time (Zulu)	Julian Date	Duration
Boom Deployed	09MAR99 14:59:57	68.62497	
F-1C	15MAR99 21:55:55	74.91383	2 m, 21 s
F-2	19MAR99 22:32:23	78.93916	5 m, 1 s
F-3	21MAR99 12:24:41	80.51714	5 m, 33 s
F-4	23MAR99 21:27:57	82.89441	8 m, 2 s
F-5	26MAR99 12:45:25	85.53154	6 m, 4 s
F-6	31MAR99 13:05:37	90.54557	4 m, 29 s
F-7	02APR99 22:09:03	92.92295	53 s 38 s
F-8	21APR99 12:22:12	111.51542	42 s
Battery Anomaly	22APR99 15:18:37	112.63793	

Figure Captions:

Fig. 1 (a) Top view and (b) Side view of ESEX showing the locations of the contamination sensors.

Fig. 2 Locations of the solar cell segments relative to the arcjet nozzle.

Fig. 3 Solar cell response to the ~~6~~^{six} primary ESEX arcjet firings. *e*

Fig. 4 Solar cell I-V curves during the ~~6~~^{six} ESEX arcjet firings.

Fig. 5 Solar cell current at selected times during the ESEX flight.

*needs to be
consistent w/
report.*

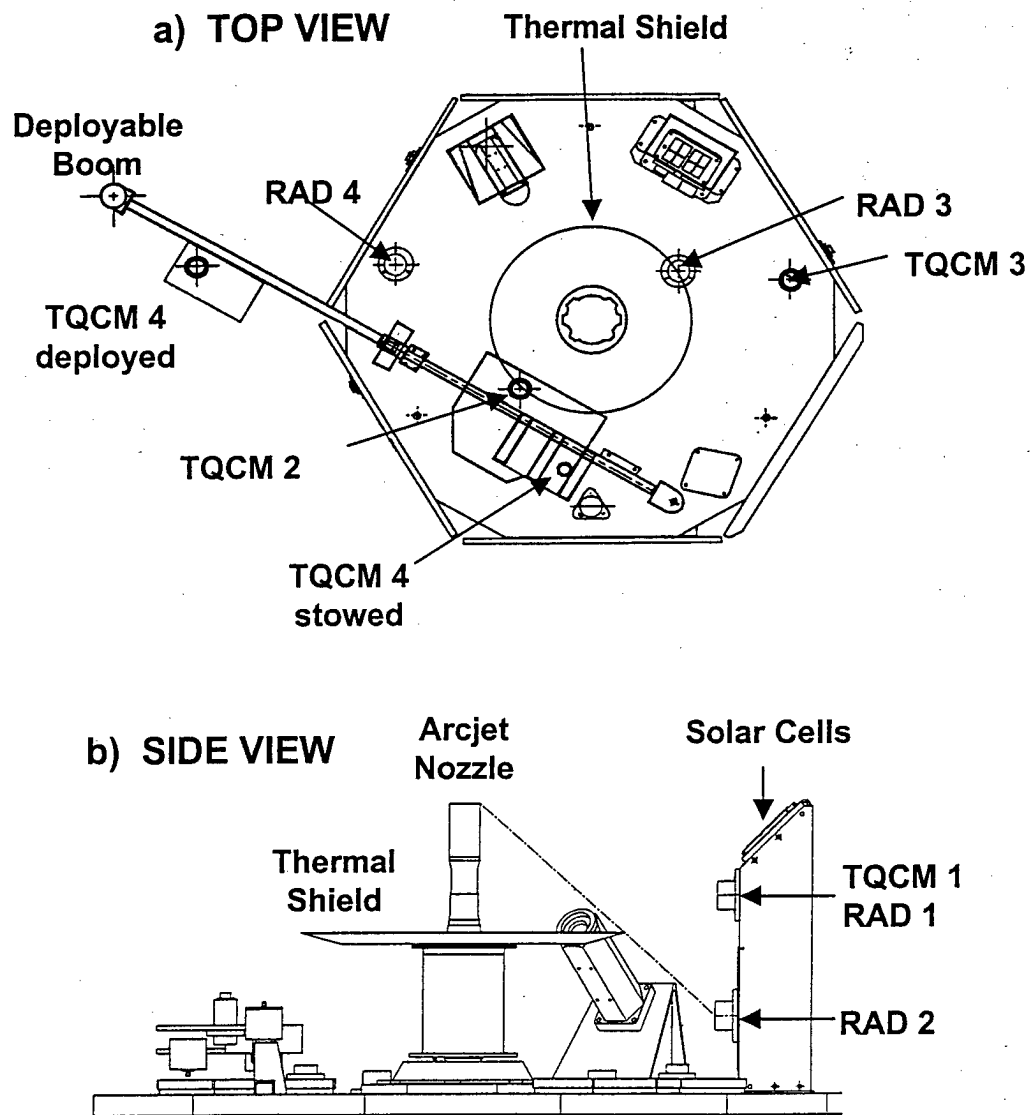

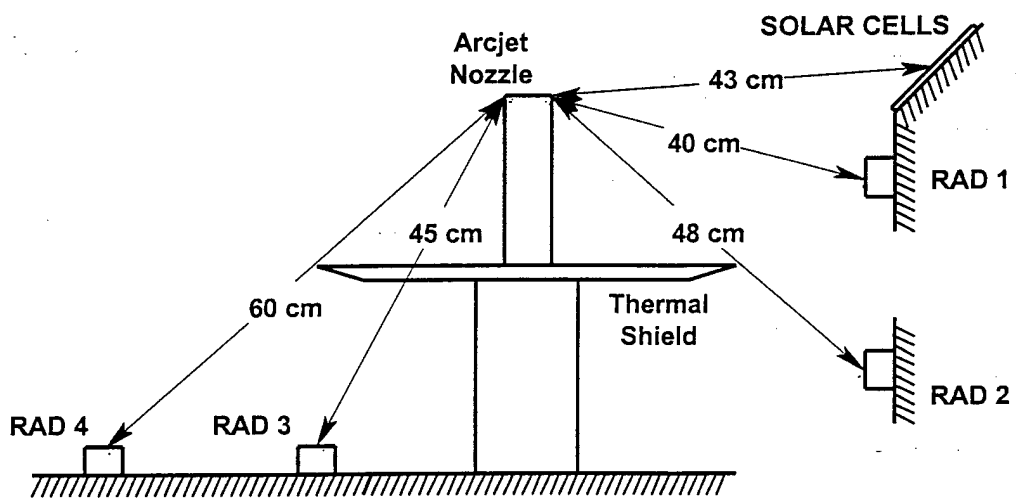

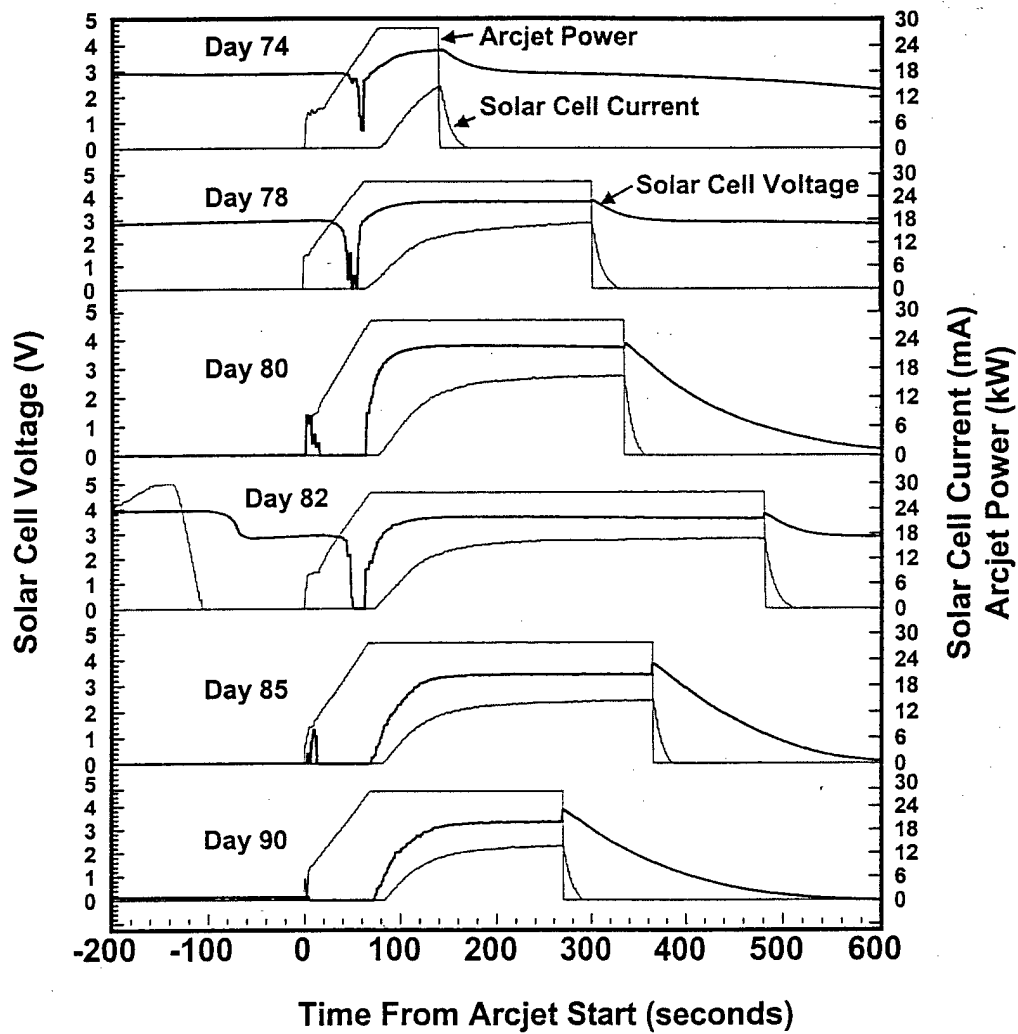

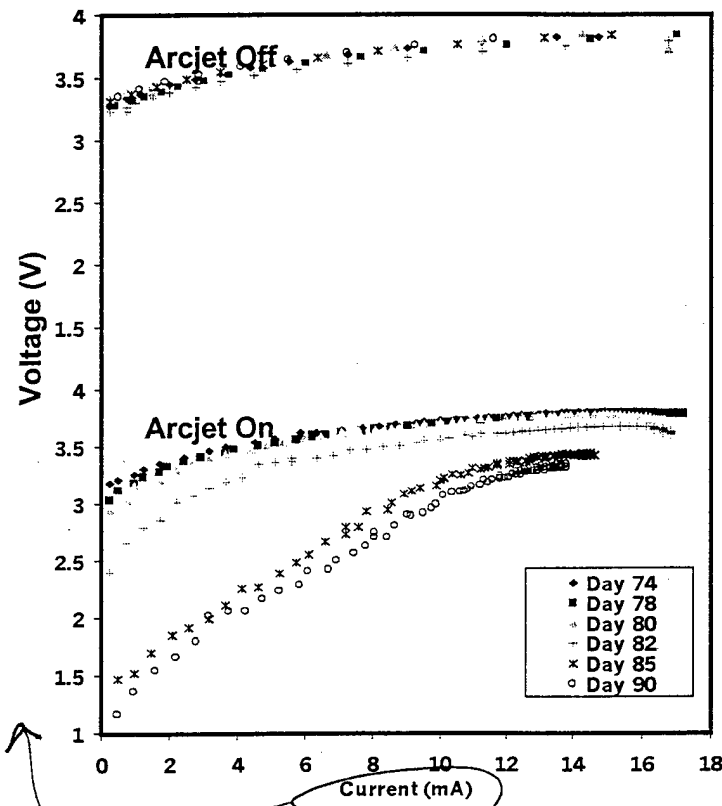

Please make font for x-axis
same size as font for y-axis

