



3009007A

MEMORANDUM FOR PR (Contractor/In-House Publication)

FROM: PROI (TI) (STINFO)

10 Jul 2000

SUBJECT: Authorization for Release of Technical Information, Control Number: **AFRL-PR-ED-TP-2000-151**  
V.V Balepin (MSE Technology Applications, Inc.), P.A. Czysz (Saint Louis University), R.H. Moszee,  
"KLIN Cycle Engine - Deeply Cooled Turbojet (DCTJ) Engine Performance Formulation"

**AIAA Journal of Propulsion and Power**  
**(Submission Deadline: none given)**

**(Statement A)**

1. This request has been reviewed by the Foreign Disclosure Office for: a.) appropriateness of distribution statement, b.) military/national critical technology, c.) export controls or distribution restrictions, d.) appropriateness for release to a foreign nation, and e.) technical sensitivity and/or economic sensitivity.

Comments: \_\_\_\_\_  
\_\_\_\_\_  
\_\_\_\_\_

Signature \_\_\_\_\_ Date \_\_\_\_\_

2. This request has been reviewed by the Public Affairs Office for: a.) appropriateness for public release and/or b) possible higher headquarters review.

Comments: \_\_\_\_\_  
\_\_\_\_\_  
\_\_\_\_\_

Signature \_\_\_\_\_ Date \_\_\_\_\_

3. This request has been reviewed by the STINFO for: a.) changes if approved as amended, b.) appropriateness of distribution statement, c.) military/national critical technology, d.) economic sensitivity, e.) parallel review completed if required, and f.) format and completion of meeting clearance form if required

Comments: \_\_\_\_\_  
\_\_\_\_\_  
\_\_\_\_\_

Signature \_\_\_\_\_ Date \_\_\_\_\_

4. This request has been reviewed by PR for: a.) technical accuracy, b.) appropriateness for audience, c.) appropriateness of distribution statement, d.) technical sensitivity and economic sensitivity, e.) military/national critical technology, and f.) data rights and patentability

Comments: \_\_\_\_\_  
\_\_\_\_\_

APPROVED/APPROVED AS AMENDED/DISAPPROVED

\_\_\_\_\_  
LESLIE S. PERKINS, Ph.D (Date)  
Staff Scientist  
Propulsion Directorate

no hyphen after '-ly' words

"KLIN Cycle Engine - Deeply-Cooled Turbojet (DCTJ)  
Engine Performance Formulation"  
~~Rocket-Based Combined Cycle for a Small Reusable Launcher (KLIN Cycle)~~

V. V. Balepin  
MSE Technology Applications, Inc., Butte, MT 59702  
P. A. Czysz ← insert space  
Saint Louis University, St. Louis, MO 63103 ← insert space  
R. H. Moszée ← insert space  
Air Force Research Laboratory, Edwards AFB, CA 93524

### Abstract

Predicted performance and features of a combined propulsion concept for a small reusable launch vehicle known as KLIN cycle are discussed. The KLIN cycle consists of a thermally integrated deeply cooled turbojet and a liquid rocket engine. The objective of this concept is to achieve a high pressure ratio in a simple, lightweight turbojet engine. The proven result is an exceptional engine thrust-to-weight ratio, as well as improved specific impulse and mass fraction of the launcher. When based on the RL10 engine family, the KLIN cycle makes a small single-stage-to-orbit and two-stage-to-orbit reusable launch vehicles feasible and very economically attractive.

### Nomenclature (to be updated)

$K_A$	air to hydrogen ratio or air cooling ratio
$g_h$	relative hydrogen flow
ATREX	Japanese air turbo ramjet
C/D	convergent/divergent
CIAM	Central Institute of Aviation Motors
CFRP	carbon fiber reinforced plastic
DCTJ	deeply cooled turbojet
DOL	DCTJ thrust fraction in total KLIN Cycle thrust
HL	horizontal landing
HTOL	horizontal takeoff and landing
IHPRPT	Integrated High Payoff Rocket Propulsion Technology Program
Isp	specific impulse
KLIN	thermally integrated DCTJ and LRE
LACE	liquid air-cycle engine
LEO	low earth orbit
LOX	liquid oxygen
LRE	liquid rocket engine
Mach	flight Mach number
MIL-SPEC	military specification
NASA	National Aeronautics and Space Administration
Nmi	nautical mile

O/F	oxidizer-to-fuel mass ratio
Pay	payload mass
RBCC	Rocket-Based Combined Cycle
RLV	reusable launch vehicle
SLS	sea level static
SSTO	single-stage-to-orbit
sSSTO	small single-stage-to-orbit
TOGW	take-off gross weight (t) ( $W_{dry} + W_{ppt} + Pay$ )
TSTO	two-stage-to-orbit
USAF	United States U.S. Air Force
VL	vertical landing
VTO	vertical takeoff
$W_{dry}$	dry weight (t) ( $W_{str} + W_{eng} + W_{syst}$ )
$W_{eng}$	engine mass (t)
$W_{ppt}$	total propellant mass (including for orbit maneuvers and deorbiting)
$W_{str}$	structure mass (t) (including the TPS and the tanks)
$W_{syst}$	system mass (t) (avionics, landing gear, hydraulics, engine attachments)

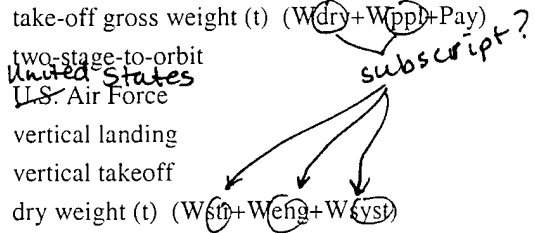

Ray wants to add  
 to intro

### Introduction

The USAF seeks innovative approaches to develop technologies that can double existing rocket propulsion capabilities by the year 2010 through specific impulse and mass fraction improvement and relatively low life cycle costs. One attractive solution is a propulsion system that integrates an existing LRE with a DCTJ, or the so called KLIN cycle. This approach makes feasible systems that are not feasible with all-rocket propulsion (small or middle-class reusable SSTO launchers). A KLIN cycle based launcher can create a new market of on-demand, small payload launch services, similar to "Federal Express" or "United Parcel Service". Additionally, it can boost space commerce activities, including space manufacturing.

Liquid Air Cycle Engine derivatives and DCTJ propulsion technology are listed among the four top priorities for detailed study in the National Research Council 1998 Report (Ref. 1).

new para? →  
 if so,  
 space  
 between;  
 if not move up  
 to previous  
 line

w/ in quotes

### Concept Description

In the proposed KLIN cycle, liquid hydrogen fuel for the rocket and the turbojet engines is used to deeply cool inlet air to 110 Kelvin (K) at sea level conditions and to 200–250 K at Mach 6. The flow diagram in Figure 1 shows integration of the DCTJ with a LRE of the RL10 family. Since the air is deeply cooled, a high-pressure ratio is attainable with simple (single spool) and lightweight turbomachinery. This results in high cycle performance and an extremely high thrust-to-weight ratio for an air-breathing propulsion system.

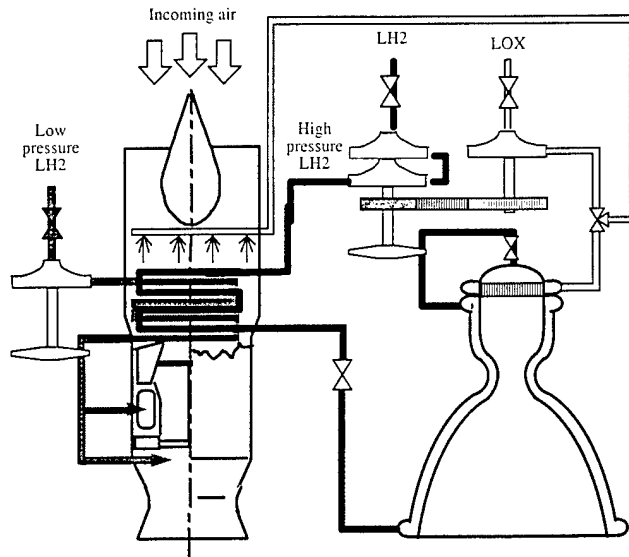

*Figure 1. Basic configuration of the RL10-based KLIN Cycle.*

The KLIN Cycle incorporates several rocket and DCTJ units. All of the DCTJ units and all or part of the LRE units operate from takeoff. The LRE units may be throttled or even shutdown for a portion of the trajectory after initial acceleration, returning to full use when the DCTJ units are shutdown. The DCTJ units are intended for operation from takeoff with a gradual reduction in thrust output until they are finally shutdown at Mach 6–6.5. The DCTJ units will be newly designed turbomachines incorporating a lightweight compressor optimized for low-temperature operation.

For a small launcher, the high performance reliable family of RL10 rocket engines is an appropriate choice. Low-cycle pressure and some features of configuration make the RL10 an ideal candidate for integration into the KLIN Cycle. The RL10 engine uses an expander cycle; therefore, it can be “naturally” integrated into the KLIN Cycle.

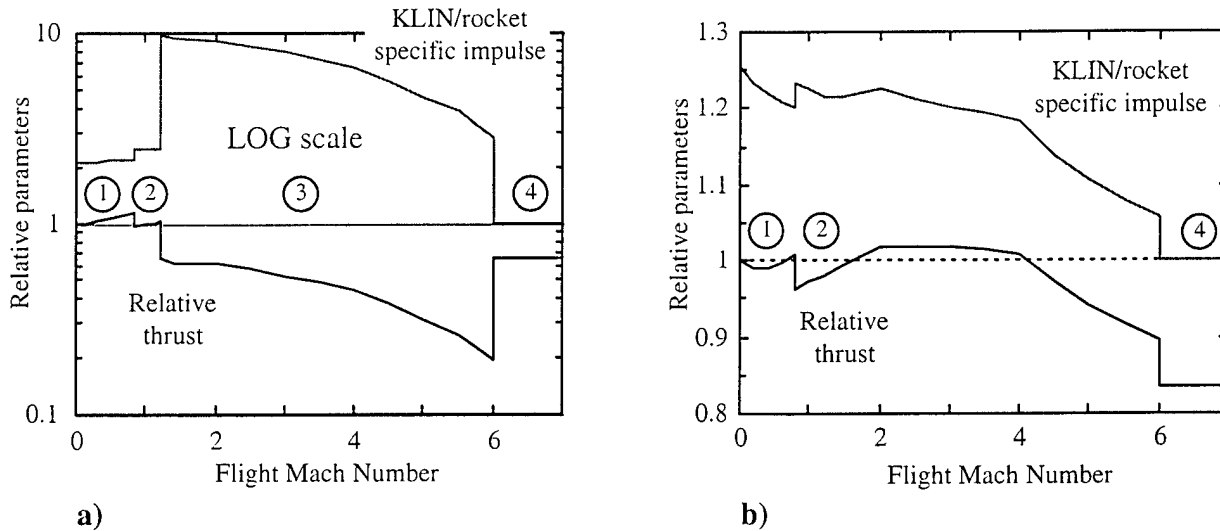

**Figure 2. Thrust and Isp profile for turbojet-dominated (a) and rocket-dominated (b) KLIN Cycles. 1. LRE and LOX-augmented DCTJ operation; 2. LOX augmentation cut off; 3. DCTJ sole operation; and 4. LRE sole operation.**

When using additional heat provided by the air precooler, a reduction in hydrogen peak pressure is possible. In turn, hydrogen pressure reduction is a favorable factor for KLIN Cycle reliability. If additional heat is used to increase chamber pressure, an RL10 thrust increase of up to 16% and a sea level Isp increase of up to 3% can be realized<sup>\*)</sup>. The higher thrust 50,000-lbf RL50 engine recently announced by the Pratt and Whitney Company could also be applied to a small RLV propulsion system. According to *Aviation Week & Space Technology*, June 21, 1999, this "engine is to cost about what an RL10 does, \$5-10 million (depending on which version), but offers approximately twice the thrust." *dated*

The KLIN Cycle offers very flexible performance characteristics and represents a unique compromise between engine weight and fuel efficiency that provides a high payload capability for the vertical takeoff launcher.

\* reference to Fig 2 - should be before it is shown.

Figure 2 shows examples of the flight scenarios of the turbojet-dominated KLIN Cycle (Figure 2a) with an air cooling ratio  $K_A=12$  and a rocket-dominated KLIN Cycle (Figure 2b) with  $K_A=4$ , as profiles of relative thrust and relative KLIN Cycle-rocket Isp. Note that the data in Figure 2a are presented on a logarithmic scale. Preferable operation modes and parameters are discussed below.

With the KLIN Cycle, various launchers (e.g., SSTO, TSTO with fly back booster), as well as different takeoff and landing scenarios (horizontal or vertical, including a powered descent and landing) are possible.

<sup>\*)</sup> Estimation for this study was done by United Technologies Research Center/Pratt&Whitney

Why bold?  
Is this a title?  
If its a note, make a footnote

A small reusable vertical takeoff/horizontal landing SSTO launcher that delivers a 330 lb payload to a 220 nmi, 28.5 degree inclination orbit was selected as the baseline launcher concept in this study. The values presented correspond to requirements for NASA's BANTAM Lifter.

Advantages of the KLIN Cycle can be summarized as follows:

- simple configuration—ideas such as an air/oxygen heat exchanger for additional air cooling, helium closed loop, or the bypass turbojet were rejected from the beginning of the concept analysis in order to maintain a simple design. Turbomachinery of the simplest possible configuration was considered, and a single spool design with no variable geometry for the compressor was employed. The addition of these features will definitely improve turbojet parameters, but they will also add mass and complexity;
- near term technology—the reliable precooler is probably the most advanced component;
- light weight structure due to the high efficiency of air processing (high specific thrust), “excess” of cooling hydrogen and a low temperature compact compressor;
- high engine thrust-to-weight ratio;
- two to three times higher Isp than for an LRE depending on the mission (the IHRPPT Program goal for year 2010 is a 26% Isp improvement); and
- known solution for icing problem.

Space (or remove others) consistency

In Reference 2, an oxygen-augmented DCTJ was considered. Subcooled LOX was proposed to inject in front of the precooler. The main objective of oxygen injection at low flight altitude is to reduce air temperature in front of the precooler below the water triple point. As shown in Reference 3, no precooler icing is expected at the air stagnation temperature in front of the precooler  $T_a^{in}$  below 273 K and at steam partial pressure  $p_{st}$  below the steam pressure in the triple point  $p_{tr}$  ( $p_{tr}=0.00623$  atm). These two conditions define seasonal speed-altitude limits of icing, and these analytical considerations were confirmed by experimental studies at the CIAM in Russia, as well as in the SLS test of the precooled ATREX engine in Japan (Ref. 3). For the KLIN cycle simulation, it was assumed that oxygen is injected into the airflow in front of the precooler from SLS to Mach  $\approx 0.8$ .

Another advantage of oxygen augmentation is a DCTJ thrust increase with almost no change in precooler and compressor hardware. Thus, oxygen injection in the amount of 10% of airflow leads to a thrust increase of approximately 20%.

### Main Parameters

The main parameters of the scheme defining performance and mass of the propulsion system are:

- $K_A$  is the ratio of the airflow rate and total (LRE fuel and turbojet fuel) hydrogen flow rate;
- $\xi = G_H^{TJ} / G_H^\Sigma$  is the hydrogen distribution factor between the turbojet and LRE, which is the ratio of the turbojet's hydrogen and total hydrogen flow rate; and
- $\varphi = G_{OX} / (G_A + G_{OX})$  is the fraction of the injected oxygen in the air/oxygen mixture.

The air to hydrogen ratio, hydrogen distribution factor, and oxygen fraction define equivalence mixture ratio as:

$$E = \frac{\xi K_0}{K_A \left( C_O^A + \frac{\varphi}{1-\varphi} \right)} \quad (1)$$

where  $K_0$  is the oxygen/hydrogen stoichiometric ratio ( $K_0=7.937$ ), and  $C_O^A$  is the oxygen mass concentration in atmospheric air ( $C_O^A=0.2315$ ). For the standard air temperature 288 K, 4% of oxygen is enough to chill down air to the water triple point if injected oxygen is subcooled to 55 K.

The total Isp of the integrated propulsion system is given by:

$$I_\Sigma = \frac{I_{TJ}(K_A\varphi + \xi) + I_{LRE}(1-\xi)(K_X + 1)}{1 + K_A\varphi + K_X(1-\xi)} \quad (2)$$

where  $I_{TJ} = R_{TJ} / (G_H^{TJ} + G_{OX})$  is the DCTJ Isp;  $I_{LRE}$  is the LRE Isp; and  $K_X$  is the oxygen/hydrogen mixture ratio in LRE.

A fraction of turbojet thrust in total thrust at sea level conditions is:

$$DOL = 1 - \frac{I_{LRE}(1-\xi)(K_X + 1)}{I_\Sigma(1 + K_A\varphi + K_X(1-\xi))} \quad (3)$$

The second important parameter along with Isp is the thrust-to-weight ratio of the propulsion system:

$$T/W = \frac{1}{\frac{\bar{M}_A^{TJ} K_{A0}}{I_\Sigma(1 + K_A\varphi + K_X(1-\xi))} + \frac{1 - DOL}{(T/W)_{LRE}\psi}} \quad (4)$$

where  $\bar{M}_A^{TJ}$  is the mass of the DCTJ per 1 kilogram per second (kg/sec) of airflow;  $(T/W)_{LRE}$  is the LRE's thrust-to-weight ratio; and  $\psi$  is the LRE throttling factor at SLS. The total mass of the turbojet includes the masses of the air intake, precooler, turbomachinery, afterburner, and nozzle.

Propulsion system efficiency was analyzed in terms of effective Isp ( $I_{SP}^E$ ), which appeared to be a very efficient comparison tool. Effective Isp provides a relation between local values of Isp, vehicle drag, and engine thrust:

$$I_{SP}^E = I_{\Sigma} (1 - X/R) \quad (6)$$

### Main Assumptions

The main assumptions of the current study are as follows:

- The vehicle is currently intended for VTO with a vehicle take off thrust-to-weight ratio of 1.3.
- The combined cycle includes a throttlable LRE of the RL10 type. Instead of throttability, a different number of engines of the LRE cluster could be used (e.g., use of 2 engines in clusters of 3 is equivalent of 67% throttling).
- The overall equivalence mixture ratio in the DCTJ was kept constant and equal to unity during acceleration. Other combinations were shown to be ~~losers~~ *ineffective?* in terms of launcher efficiency.
- The design point of the precooler corresponds to SLS conditions. The initial air temperature behind the compressor was  $T_a=110$  K, and the initial pressure recovery factors for air intake and precooler were  $\sigma_{in}=0.95$  and  $\sigma_{pc}=0.85$ . The air intake pressure recovery factor profile along the trajectory was taken close to the MIL-SPEC (~~military specification~~ *already defined in acronym list*) standard.
- The compressor pressure ratio at SLS conditions was taken as  $\pi_c=30$ . Low total compression work allows a single spool compressor at this ratio.
- The compressor and turbine efficiencies were assumed as  $\eta=0.82$ .
- CFRP with the density  $\rho=2,000$  kg/m<sup>3</sup> was assumed as the material that makes up 50% of the compressor rotor and stator pieces, as well as the precooler shell.
- A shell-and-tube precooler of original configuration was selected. Stainless steel tubes of 2 mm outer diameter with wall thickness 0.1 mm was considered.
- Subcooled LOX at 55 K is injected in front of the precooler in the amount of 10% of the airflow from SLS static conditions up to Mach  $\approx 0.8$  and an altitude of  $H \approx 3.5$  km to prevent precooler icing and increase initial DCTJ thrust.
- An expandable dual-position bell nozzle was used for the LRE, and a self-adjusted flow using the vehicle afterbody was assumed for the DCTJ.

- In all the calculations, the vehicle structure index was equal to 19 kilograms/square meter ( $\text{kg/m}^2$ ).

Other assumptions can be found in following sections.

### Effective Isp Comparison

is? The sentence is incomplete

Equation 6 gives the definition of the so-called  $I_{SP}^E$ , which is the function of Isp and vehicle drag-to-thrust ratio. This parameter (not Isp) in combination with the engine specific weight define launcher efficiency. It should be noted that indirectly (through vehicle drag) which is particularly dependent on the vehicle mass/volume ratio or average vehicle density  $I_{SP}^E$  also includes the overall oxygen/hydrogen ratio, which drops along with a  $K_{AO}$  increase.

broke up sentence - sentence is too long & hard to follow

indirectly

is accomplished

by engine drag..

Figure 3 shows  $I_{SP}^E$  vs. flight Mach number for an all-rocket launcher and a family of curves for the KLIN launcher with the initial air-to-hydrogen ratio  $K_{AO}=6$ . Curves in this family differ by the rocket engine control law characterized by the rocket engine throttling factor  $\lambda$ . In Figure 3 the throttling factor varies in the range of  $\lambda=0.3333-1.0$ . The latter case means that the rocket engine operates with full thrust throughout the trajectory. The dotted line corresponds to case, which showed the best vehicle efficiency in previously done analyses. This case is characterized by full thrust LRE operation at the initial acceleration to Mach 1.5, 50% LRE throttling (Isp increases by 15%) and further LRE throttling to 33% at Mach 4.0 (Isp increases by 11%). The DCTJ units in all considerations produces maximum possible thrust.

Initially, the intention of the LRE throttling was to increase launcher efficiency through Isp increase. However, according to Figure 3, LRE throttling has negative impact on  $I_{SP}^E$  because of significant thrust reduction (by 75% and 35% at Mach 1.5 and 4.0 correspondingly). At Mach  $>4.5$ ,  $I_{SP}^E$  of the such a controlled KLIN Cycle becomes lower than the pure LRE. It was concluded from Figure 3 that for the KLIN Cycle with  $K_{AO}=6$ , which provided the best launcher efficiency, the best control law would be  $\lambda=\text{const}=1.0$  (i.e., the LRE should operate with the full thrust during the combined cycle mode because it provides the highest level of the  $I_{SP}^E$ ). Specific engine weight for all cases shown in Figure 3 is the same (except for the rocket engine).

A concluding calculation was conducted for the KLIN Cycle with  $K_{AO}=6$  and  $\lambda=\text{const}=1.0$ .

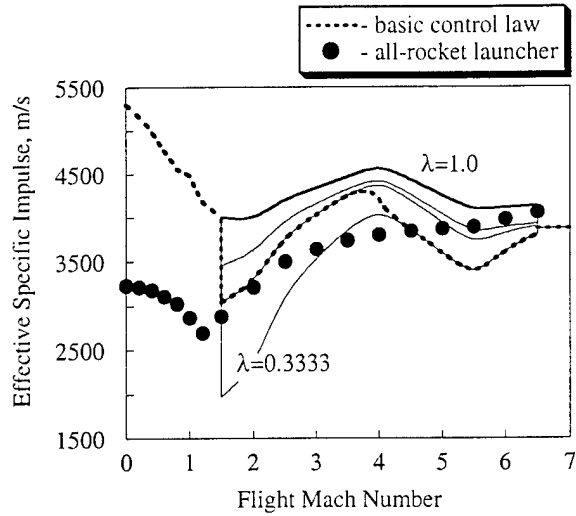

Figure 3. Comparison of the effective specific impulse.

### DCTJ Sizing and Operation

Figure 4 gives a new configuration of the DCTJ drawn in the current study. It is a dimensional scheme with major units sizing for SLS thrust of 6.95 tons. Table 1 gives DCTJ parameters in the main stations as shown in Figure 4. The following is a brief description of the parameters and process at each station.

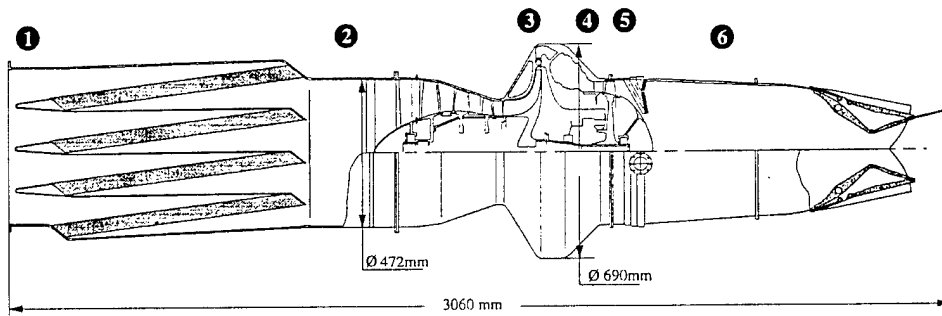

Figure 4. Dimensional scheme of the 7-ton thrust DCTJ.

Table 1. DCTJ parameters at SLS.

Station in Figure 4	Temperature, K	Pressure, bar
1	243	0.92
2	110	0.782
3	331	23.5
4	1451	22.3
5	1229	12.2
6	2505	11.8

**Station 1** (in front of precooler). The temperature of 243 K is the result of subcooled oxygen (at 55 K) injection into standard temperature air (at 288 K) in the amount of 10% (note: the oxygen injection system is not shown in Figure 4). This allows it to conduct the process in the precooler with frozen out moisture and to prevent icing.

**Station 2** (behind precooler, in front of compressor). Airflow passes through the precooler and is chilled to 110 K with a pressure recovery factor of 0.85. Hydrogen discharge temperature from the precooler is 85 K, and the pressure drop is slightly above 2%. The precooler is the new 4-“teeth” ZUB configuration.

**Station 3** (compressor discharge). The 4-stage compressor (one centrifugal stage) increases air pressure by a factor of 30 at the design point in SLS conditions. Air is heated in the compressor to 330 K at the design point. Along the trajectory, pressure ratio significantly decreases. The maximum expected temperature behind the compressor is within 550 K and can be reduced if necessary. Therefore, lightweight composite materials or light alloys (aluminum-based) can be utilized as the primary materials for compressor design.

Axial compressor stages are assumed to produce equal pressure ratio ( $\pi_c=1.92$  per stage). The average work per stage is as low as 28 kilojoules (kJ)/kg, which is far below the typical maximum range of 50–70 kJ/kg per stage for turbojet compressors. The centrifugal stage produces a pressure ratio  $\pi_c=4.23$  and work 109 kJ/kg, which is also within modern level.

**Station 4** (combustor exit). In the DCTJ combustor, fuel lean combustion takes place to provide a combustion temperature  $T<1,700$  K. Hydrogen flow through the combustor is variable depending on airflow and oxygen concentration in the airflow.

**Station 5** (turbine exit). Only the 1-stage turbine serves to drive the compressor. The expansion ratio in the turbine is nearly two, thus providing total work of the turbine stage of approximately 200 kJ/kg, which is far below maximum modern range of 400–500 kJ/kg.

**Station 6** (afterburner). In the afterburner, stoichiometric combustion of the triple mixture is completed after hydrogen addition. According to Table 1-3, temperature in afterburner can be as high as 2,505 K. This shows that regenerative cooling of the afterburner is likely to be required.

Combustion products expand in the DCTJ convergent/divergent variable geometry nozzle. It could also be integrated with the vehicle afterbody (e.g., as an aerospike-type nozzle). Table 1-4 shows ~~some~~ geometry and mechanical parameters of the DCTJ at SLS conditions. Note that moderate compressor tip speed corresponds to significant tip Mach number because of the very low speed of sound at temperatures of 110 K. This issue was studied in Reference 4, which concluded that compressor efficiency and pressure ratio per stage will not be affected by a high tip Mach number.

*X page break to keep table on one page*

*Table 1-1: Some geometry and mechanical parameters of the DCTJ. 2*

Relative hub diameter	0.5
-----------------------	-----

Compressor tip speed, m/s	350
Compressor tip relative Mach number	1.8
Design spool speed, RPM	14,686
Compressor inlet Mach number	0.54

### Baseline KLIN Cycle

Engine performance and weight analyses is closely connected with trajectory analyses and launcher sizing. The KLIN Cycle (as described in this section) is a result of the trajectory analyses performed in the study.

It was proven in the efficiency analyses of a small RLV powered by the KLIN Cycle that minimums of the TOGW, dry weight, and engine weight correspond to an initial air to hydrogen ratio  $K_{A0}=6.0$  (see Figure 7 in the next section). This means that the optimal (for the considered mission) KLIN Cycle is more rocket-dominated than has been previously considered. In addition, mentioned minimums correspond to the KLIN Cycle operation mode without LRE throttling during simultaneous operation with the DCTJ because this mode provides the highest value of the  $I_{SP}^E$  (Equation 6). This fact has four favorable results for the KLIN Cycle: 1) the baseline KLIN Cycle is simpler to control (compare thrust profiles in Figure 2a and Figure 2b); 2) a better air/hydrogen ratio is maintained during DCTJ operation at higher speed, which allows more favorable air and hydrogen temperatures at precooler exits; 3) a higher initial LRE thrust fraction eliminates the necessity of a spare engine to provide adequate thrust after transition to the all-rocket mode resulting in a propulsion system mass saving; and 4) a lower optimal DCTJ thrust fraction reduces risks of KLIN Cycle development.

The following is a description of the baseline KLIN Cycle operation modes and the major internal parameters of the DCTJ. Major KLIN Cycle parameters were conventionally divided on propulsion performance (shown in Figure 5) and internal engine parameters (shown in Figure 6).

Once it was shown in the launcher analyses that it is not necessary to throttle the LRE after initial acceleration, control law of the reference KLIN Cycle is similar to what is shown in Figure 2 for the rocket-dominated KLIN Cycle. A new flight scenario is shown in Figure 5a in terms of  $I_{sp}$  and relative thrust variations in acceleration. There are three distinctive operational modes.

**Mode 1** (from takeoff to Mach=0.8) corresponds to simultaneous operation of all DCTJ units with oxygen augmentation and all the LRE units. Maximum absolute thrust required for VTO and moderate  $I_{sp}$  are produced. Subcooled oxygen injection in the amount of 10% of the airflow in front of precooler prevents icing and provides an approximately 20% DCTJ thrust increase with the same engine mass.

minor point, but figures 5a-d are arranged  
 whereas figures 1e-a are arranged

a b  
 c d  
 a d  
 b e  
 c

→ tricks the reader going from one to the other who following text

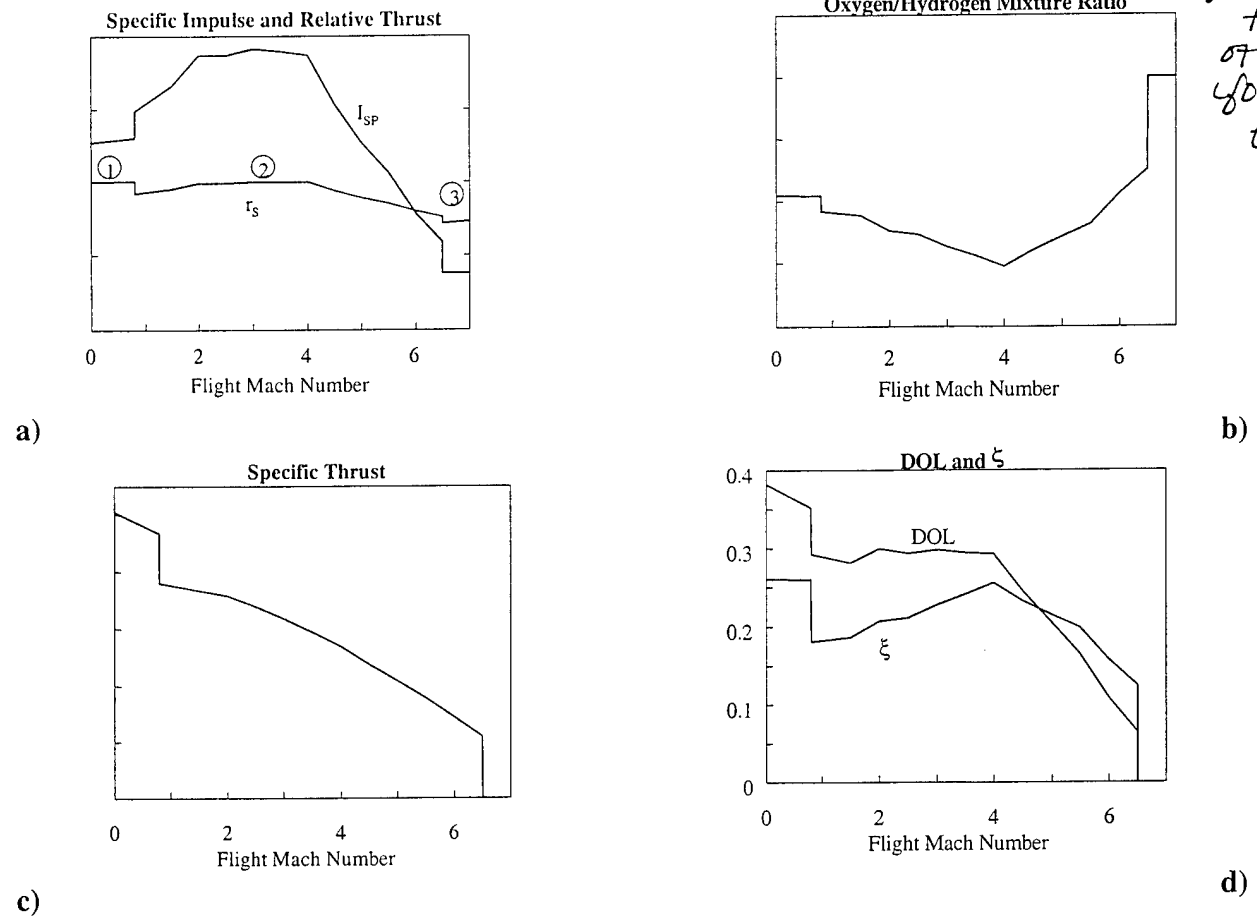

Figure 5. Performance of the reference KLIN Cycle.

where is reference to 5b, 5c?  
 if possible, try to reference the figure before it is shown

**Mode 2** (in the range of Mach=0.8–6.5) begins after oxygen injection is cutoff. Initially, thrust slightly decreases as  $I_{sp}$  increases (Figure 5a). As the chosen trajectory provides significant airflow increase through the turbomachinery (Figure 6a) up to Mach 4,  $I_{sp}$  increases and remains rather high up to this flight speed. Mach 4 was selected as the design point for air intake. This means that the maximum capture area of the variable geometry air inlet is designed for Mach 4 and further acceleration at higher altitude results in an airflow decrease through the air inlet. In other words, the air inlet is an airflow limiter after Mach 4 as turbomachinery is before Mach 4. To support turbomachinery operation at Mach > 4.0, actual spool speed should be gradually reduced (as shown in Figure 6a).

Hydrogen flow is also reduced at higher Mach number in order to provide stoichiometric combustion in the DCTJ. In the beginning of Mode 2, DCTJ thrust fraction DOL decreases along with hydrogen fraction for the DCTJ  $\xi$  (Figure 5d) and then remains nearly constant up to Mach 4. Beyond Mach 4, the DCTJ thrust fraction in total KLIN Cycle thrust (DOL) sharply decreases to approximately 7% at Mach 6.5. A very smooth acceleration not exceeding 1.5 g is typical for the combined mode operation, and it is two times lower than in the all-rocket case.

**Mode 3** (from Mach 6.5 to orbital speed) a pure rocket mode begins after DCTJ cutoff, and LRE sole operation continues. The vehicle thrust-to-weight ratio should be equal to or greater than unity from the beginning of this operational mode. To meet this condition spare LRE unit(s) were included in the previous KLIN Cycle configuration, which were activated in this mode. This resulted in higher launcher weight and lower efficiency. In the current reference case, a spare LRE is not required due to rather high LRE fraction in the initial thrust. At Mach 6.5, after transition on all-rocket mode, vehicle thrust-to-weight ratio is approximately 1.3.

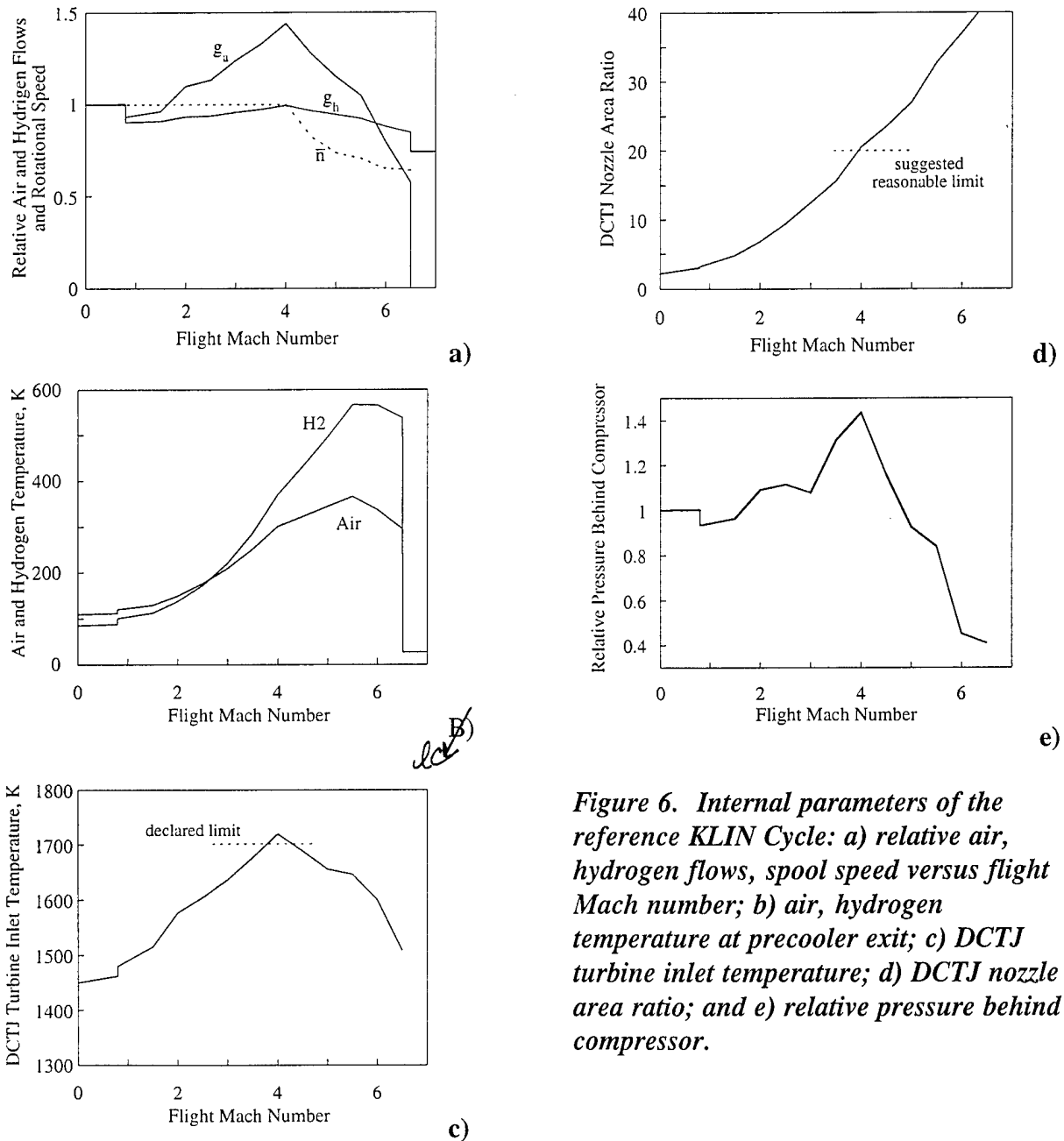

**Figure 6. Internal parameters of the reference KLIN Cycle: a) relative air, hydrogen flows, spool speed versus flight Mach number; b) air, hydrogen temperature at precooler exit; c) DCTJ turbine inlet temperature; d) DCTJ nozzle area ratio; and e) relative pressure behind compressor.**

Additional comments to Figures 5 and 6 are in order. The reference ~~KLIN Cycle~~ <sup>already defin</sup> ~~rocket-based combined cycle~~ (RBCC) provides rather moderate Isp at an unusually high thrust profile (Figure 5a). Thrust changes range from 76%–101% of the SLS thrust. Figure 5b shows a profile of the oxygen/hydrogen mixture ratio. Oxygen and hydrogen flow rates include total LRE and DCTJ consumption. A mixture ratio obtained for the reference cycle varies from 4.5 to 5.5 in the combined cycle mode is much higher than in previous studies where it was in the range of 0–4 (0 corresponds to DCTJ sole operation). This factor is favorable for launcher efficiency because it reduces launcher volume and corresponding drag.

Figure 5c shows DCTJ specific thrust (i.e., thrust per 1 kg per second of airflow). SLS specific thrust is higher than 2,000 meters per second (m/s), which is a uniquely high level. Modern military turbofans with ultra low bypass ratios provide specific thrust of 1,000–1,200 m/s. The only fabricated and tested precooled turbomachine—the ATREX engine—reached 700 m/s, which the DCTJ provides at Mach 5.5. This unique level of specific thrust, along with very comfortable conditions in the compressor inlet (air temperature in front of compressor is shown in Figure 6b), allows a very high thrust-to-weight propulsion system design. DCTJ contribution to SLS thrust DOL=38% (Figure 5d), as it consumes approximately 26% of the total hydrogen flow.

One of the important internal parameters is turbine inlet temperature. Its variation with flight Mach number is shown in Figure 6c. It can be seen that the turbine temperature is within the declared upper limit of 1,700 K at all times. It slightly exceeds this limit and reaches 1,720 K at Mach 4. This excess can be easily offset by appropriate DCTJ control, or limited extension by 20K can be discussed. It should be noted that DCTJ performance can be substantially improved if control law providing  $T_T = \text{const}$  is applied. In this case, an assumed limit of 1,700 K can be kept from the SLS (currently SLS  $T_T = 1,450$  K). This will result in substantial DCTJ thrust and thrust-to-weight ratio increase.

According to Figure 6b, the maximum hydrogen temperature reached after the precooler is 567 K at Mach 5.5–6.0. The possibility to use hydrogen at such temperatures as rocket combustor coolant can be confirmed in detailed LRE analyses. If necessary, several measures to reduce this temperature can be offered.

Figure 6d shows that ideally the DCTJ requires the nozzle area ratio to vary in the range of 2.5 to 20 and higher. The possibility to provide such area ratios and its impact on nozzle mass should be examined in further studies. Note that a higher nozzle area ratio can be provided by nozzle integration into the vehicle afterbody. In this case, flow self-adjustment will control the expansion process.

Figure 6e shows the profile of the relative pressure behind compressor of the DCTJ (SLS pressure is equal 23.5 bar and taken as 1.0 in Figure 6e). Maximum pressure increase (44%) corresponds to Mach 4. If this pressure peak is not acceptable from the DCTJ perspective, it can be easily shaved (at the expense of DCTJ thrust) by several means such as an artificial pressure drop increase in the air inlet or spool speed reduction.

**Other critical parameters, for example DCTJ turbine inlet temperature (Figure 6c), can also be traded for current engine efficiency.**

To conclude the reference KLIN Cycle analyses, it should be noted that the high efficiency of the KLIN launcher is a result of the synergy of the engine  $I_{sp}$ , high thrust profile (these two provide  $I_{sp}^E$  increase by more than 20% compared to an all-rocket launcher), oxygen/hydrogen mixture ratio higher than for the turbojet-dominated KLIN Cycle, and a very high engine thrust-to-weight ratio (for combined cycles) of 33-35.

It was shown in the described phase of the efficiency analyses of a small RLV powered by the KLIN Cycle, that minimum values of gross take-off weight, dry weight, and engine weight correspond to the initial air to hydrogen ratio  $K_{AO}=6.0$ . This means that the optimal (for the considered mission) KLIN Cycle is more rocket-dominated than has been previously considered. In addition, stated minimums correspond to the KLIN Cycle operation mode without LRE throttling during simultaneous operation with the DCTJ because this mode provides the highest value of the  $I_{sp}^E$ . This fact has four favorable results for the KLIN Cycle: 1) the baseline KLIN Cycle is simpler to control; 2) a better air/hydrogen ratio is maintained during DCTJ operation at higher speed, which allows for more favorable air and hydrogen temperatures at the precooler exits; 3) a higher initial LRE thrust fraction eliminates the necessity of a spare engine to provide adequate thrust after transition to the all-rocket mode, thereby resulting in a propulsion system mass saving; and 4) a lower optimal DCTJ thrust fraction reduces risks of KLIN Cycle development.

### Summary of KLIN Launcher Analyses

The trajectory was determined using an optimum trajectory program that incorporated an engine cycle description and a sizing routine based on the one documented in Hypersonic Convergence (Ref. 5). For the part of the flight that uses aerodynamic lift, the program uses the technique maximizing the specific excess power, namely:

$$P_s = V \cdot \left( \frac{T - D}{W} \right) \quad (7)$$

This is analogous for a minimum fuel climb for a high performance combat aircraft.

The trajectory-averaged characteristics, weight ratio, oxidizer to fuel ratio, propellant density, and thrust to drag ratio were used as inputs into sizing program from Reference 1 to confirm the vehicle size and weight. The sizing program from Reference 5 simultaneously solves the governing weight and volume equations. This procedure was done initially for original original KLIN cases provided for a blended body configuration concept. The analysis identified the KLIN Cycle that resulted in the smallest, lightest launcher.

A summary of results is shown in Figure 7. The relative TOGW, dry weight, and propulsion system weight are plotted vs. air-to-hydrogen ratio. Corresponding weights of the all-rocket launcher are taken as 100%. As Figure 7 shows, the minimum TOGW

would be approximately 40%, and the dry weight and engine weight would be 70% of the corresponding weights of an all-rocket system. These minimums are rather gentle, and one may see that in the range of  $K_{AO} = 5-8$ , the KLIN Cycle launcher masses do not change too much. The minimum of the launcher dry weight corresponds to the DCTJ contribution in SLS thrust  $DOL=30\%-45\%$ .

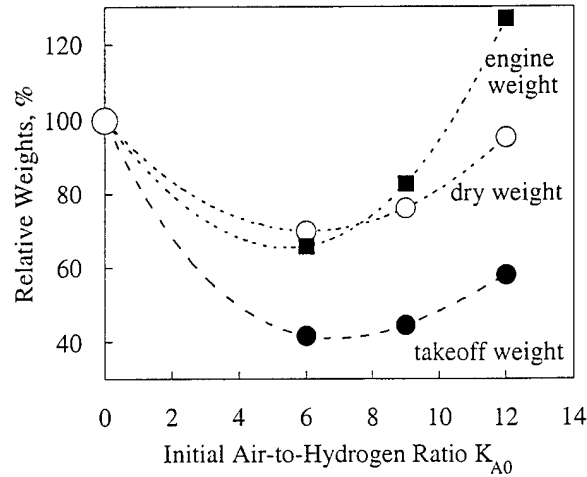

**Figure 7. Comparison of the weights of all-rocket launcher and the KLIN Cycle launcher as a functions of the air-to-hydrogen ratio.**

Strictly speaking, the KLIN Cycle launcher and all-rocket points in Figure 7 cannot be connected by one curve because the KLIN Cycle launcher and the all-rocket launcher were evaluated for different trajectories. It is done only for visualization purposes. The impact of the values of  $K_{AO}$  in the range of 5–8 is minimal. The system designer has the freedom to choose the combinations of turbojets and rockets from available engines within this range. This provides a significant flexibility to integrate the launcher from available engines.

Following confirmation of the trajectory results for the KLIN Cycle, a parametric investigation was completed to identify the minimum weight and size practical vehicle suitable for a small satellite launcher powered by the KLIN Cycle propulsion system. This involved three steps:

1. Evaluating different configuration concepts.
2. Evaluating the impact of slenderness on the selected concept.
3. Examining the geometry to minimize weight and size.

The resulting analysis identified a spatular trapezium as the best configuration for a practical small satellite launcher (Figure 8). For the 150 kg small satellite payload, the resulting launcher was 20 meters in length with a dry weight of 12 tons, a gross weight of

62 tons with <sup>x?</sup> planform area of 100 m<sup>2</sup>, and a total volume of 160 m<sup>3</sup> (approximate numbers are given). This configuration required seven RL10-type rocket engines with 7.7 tons SLS thrust each and four turbojets of 6.5 tons SLS thrust each.

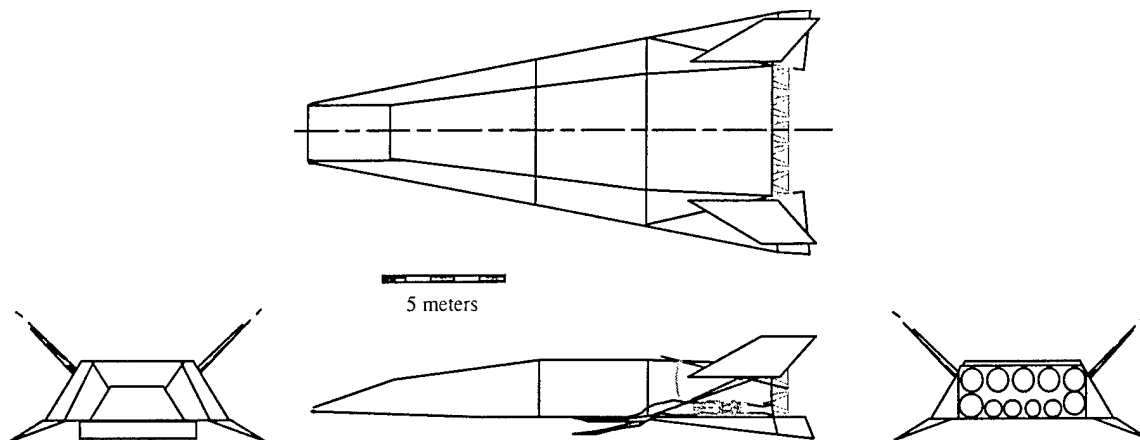

**Figure 8. KLIN Cycle-powered small satellite launcher.**

Major observations from the trajectory and sizing study are as follows:

- The configuration concept can result in a factor of two for size and weight.
- Too slender a vehicle greatly increases weight.
- The baseline configuration is a FDL-7 type trapezoidal hypersonic glider.
- A spatular nose configuration permits greater volume at the same drag.
- A spatular nose configuration reduces weight and size.
- The KLIN Cycle sizing data is very consistent with prior demonstrator sizing results (Refs. 6, 7, 8).
- The KLIN Cycle small satellite launcher is smaller and lighter than a corresponding RBCC powered demonstrator that operates at a higher airbreathing speed.
- The availability of both turbojet engine and expander cycle rocket engines in the usable thrust class make the KLIN Cycle an attractive option for an SSTO demonstrator and small satellite launcher.

page break

Future Study  
↓

A bench-scale demonstration is planned for the follow-on phases of the project. Benefits of the KLIN Cycle can be demonstrated with a somewhat modified existing small turbojet. Several engine manufacturers have expressed interest in cooperating in further phases of the study.

Currently, precooler design is being developed along with the test plan which includes demonstration of the reliable precooler operation in relevant conditions and ways to resolve main operational issues.

Figure 9 shows a precooler assembly with one of the existing small turbine engines.

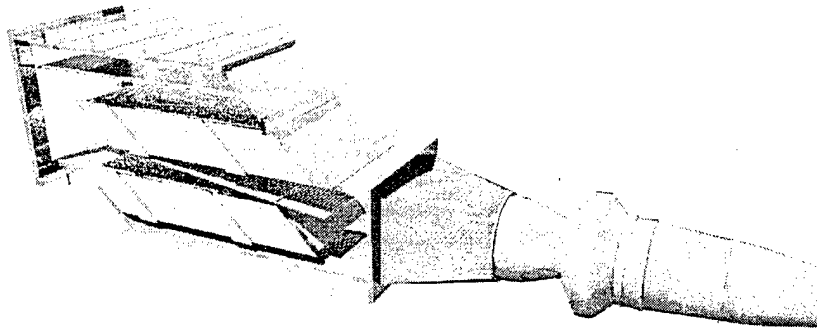

*Figure 9. DCTJ demonstrator.*

## Conclusions

A KLIN cycle baseline VTO SSTO RLV to deliver 330 lb payload to LEO was sized at TGOW 62 tons and a dry weight of 12 tons. The propulsion system configuration for the launcher has been defined. It includes seven RL10-type engines with 7.7 tons SLS thrust each and four DCTJs with 6.5 tons SLS thrust each.

The performance of the expander cycle rocket engine of the RL10 type can benefit from integration into the KLIN Cycle. As a result of additional heating of the hydrogen fuel, it is possible to increase LRE Isp by approximately 3% and thrust by approximately 16% (if turbopump control by +20% is assumed) with the same hardware. These advantages significantly offset the drawbacks of low chamber pressure LRE use in SLS conditions.

The DCTJ sizing was completed. Three new types of precoolers were examined. A 4-“tooth” ZUB-type precooler was selected for further DCTJ analyses and modeling.

The optimum KLIN Cycle corresponds to an initial air-to-hydrogen ratio of  $K_{AO}=6$ . The thrust-to-weight ratio of this engine was estimated at 33.1, if it is based on an LRE

with  $T/W=43.6$ . The most simple LRE control law (with full thrust) is the most efficient for the reference KLIN Cycle, as it provides the highest profile of effective specific impulse for  $K_{AO}=6$ .

The KLIN cycle based upon an RL10 rocket engine makes a small reusable launcher of the BANTAM class payload feasible and economically attractive and is within the capability of today's industry. This KLIN cycle will create a new market of on-demand small payload launch services much like a space-launched FedEx or UPS.

1st time - TM' - need to go on every one?  
"Federal Express" or "United Parcel Service."

### Acknowledgment

This study was conducted under U.S. Air Force SBIR Contract F04611-99-C-0047.

### References

1. *Maintaining U.S. Leadership in Aeronautics. Breakthrough Technologies to Meet Future Air and Space Transportation Needs and Goals*, National Research Council, National Academy Press, Washington, D.C., 1998.
2. V. Balepin, M. Maita, and S.N.B. Murthy, "Third Way of Development of SSTO Propulsion," *Journal of Propulsion and Power*, Vol.17, No.5, 1999.
3. N. Tanatsugu; V. Balepin; T. Sato, et al., "ATREX Engine Development: First Practical Experience of Precooled Turbomachinery," *Proceedings of the 5th AAAF Intl. Symp. Propulsion in Space Transportation*, 1996, pp. 19.25-19.29.
4. V. Balepin and F. Breugelmanns, "Combined Cycle for SSTO Rocket: Definition of the Key Technologies," *Proceedings of the XIII ISOABE Symposium*, 1997, pp.987-994.
5. Czysz, Paul, "Hypersonic Convergence, Volumes 1 through 10" Text for Hypersonic Aero-Propulsion Design Course AE-P493-50, Parks College of Engineering and Aviation, Saint Louis University, 8th Edition, December 1998.
6. Czysz, Paul A., Froning, H. David, and Longstaff, Roger, "A Concept for an International Project to Develop a Hypersonic Flight Test Vehicle," *Proceedings of The International Workshop on Spaceplanes/RLV Technology Demonstrators*, Tokyo, Japan, March 1997.
7. Czysz, Paul A., Froning, H. David, and Longstaff, Roger, "A Concept for an International Project to Develop a Hypersonic Flight Test Vehicle," AIAA 97-2808, 33rd AIAA Joint Propulsion Conference, Seattle, Washington, July 1997.
8. Froning, H.D., Jr. and Leingang, J.L., "Impact of Aerospace Advancements on

---

Capabilities of Earth-to-Orbit Ships, Presented at the 41st IAF Congress,  
Dresden, Germany, October 1990.