

**DOT/FAA/AR-02/1**

Office of Aviation Research  
Washington, D.C. 20591

# **An Investigation of the Effect of Number of Time Steps on Ice Shapes Calculated by an Ice Accretion Code**

April 2002

Final Report

This document is available to the U.S. public  
through the National Technical Information  
Service (NTIS), Springfield, Virginia 22161.



**U.S. Department of Transportation  
Federal Aviation Administration**

**DISTRIBUTION STATEMENT A**  
Approved for Public Release  
Distribution Unlimited

**20020821 012**

## **NOTICE**

This document is disseminated under the sponsorship of the U.S. Department of Transportation in the interest of information exchange. The United States Government assumes no liability for the contents or use thereof. The United States Government does not endorse products or manufacturers. Trade or manufacturer's names appear herein solely because they are considered essential to the objective of this report. This document does not constitute FAA certification policy. Consult your local FAA aircraft certification office as to its use.

This report is available at the Federal Aviation Administration William J. Hughes Technical Center's Full-Text Technical Reports page: [actlibrary.tc.faa.gov](http://actlibrary.tc.faa.gov) in Adobe Acrobat portable document format (PDF).

1. Report No. <b>DOT/FAA/AR-02/1</b>		2. Government Accession No.		3. Recipient's Catalog No.	
4. Title and Subtitle <b>AN INVESTIGATION OF THE EFFECT OF NUMBER OF TIME STEPS ON ICE SHAPES CALCULATED BY AN ICE ACCRETION CODE</b>				5. Report Date <b>April 2002</b>	
				6. Performing Organization Code	
7. Author(s) <b>James Riley and Rosemarie McDowall*</b>				8. Performing Organization Report No.	
9. Performing Organization Name and Address <b>Federal Aviation Administration William J. Hughes Technical Center Airport and Aircraft Safety Research and Development Flight Safety Research Section Atlantic City International Airport, NJ 08405</b>				10. Work Unit No. (TRAVIS)	
				11. Contract or Grant No.	
12. Sponsoring Agency Name and Address <b>U.S. Department of Transportation Federal Aviation Administration Office of Aviation Research Washington, DC 20591</b>				13. Type of Report and Period Covered <b>Final Report</b>	
				14. Sponsoring Agency Code <b>AIR-100</b>	
15. Supplementary Notes <b>The FAA William J. Hughes Technical Center Technical Monitor was James Riley.</b>					
16. Abstract <p>A brief investigation was conducted of the effect of the number of time steps used by the ice accretion code LEWICE 2.0 in determining an ice shape. The investigation included a study of the LEWICE 2.0 validation database and approximately 30 additional LEWICE 2.0 runs.</p> <p>For more than 90 percent of LEWICE 2.0 cases in the validation database, the number of time steps used in calculating the ice shape was different from the "default" number of time steps determined by LEWICE 2.0 with the automatic time-stepping feature on. In all these cases, the number of time steps was equal to the IFLO input value, which was determined in accordance with a "minutes rule." The authors recommend that the minutes rule be incorporated into LEWICE 2.0 so that the default number of time steps determined by LEWICE 2.0 is consistent with the number of time steps used for the runs in the validation database. The accuracy of LEWICE 2.0 when using the current default number cannot be determined from the validation database.</p> <p>It was also found that the accuracy of LEWICE 2.0 ice shapes does not improve when the number of time steps is increased beyond a certain value. Specifically, when the number of time steps is increased beyond about 25 or 30, depending on the conditions, the ice shape predictions tend to diverge, and the upper horn (if present) tends to "droop." The authors recommend that the LEWICE 2.0 user be warned against inputting too large a number of time steps.</p>					
17. Key Words <b>Ice accretion code, Time step, LEWICE</b>				18. Distribution Statement <b>This document is available to the public through the National Technical Information Service (NTIS) Springfield, Virginia 22161.</b>	
19. Security Classif. (of this report) <b>Unclassified</b>		20. Security Classif. (of this page) <b>Unclassified</b>		21. No. of Pages <b>13</b>	22. Price

## TABLE OF CONTENTS

	Page
EXECUTIVE SUMMARY	v
1. INTRODUCTION	1
2. DETERMINATION OF NUMBER OF TIME STEPS	1
3. EFFECT OF NUMBER OF TIME STEPS	3
4. RECOMMENDATIONS	8
5. REFERENCES	8

## LIST OF FIGURES

Figure	Page
1 Run 072501	3
2 Run 072503	4
3 Run 072501 With Additional Time Steps	4
4 Run 072503 With Additional Time Steps	5
5 Time Step Tests for Run 1-23-Run8	6
6 Time Step Tests for Run 125	7
7 Time Step Tests for Run 231	7

## LIST OF TABLES

Table	Page
1 Comparison of Values of N and IFLO for LEWICE Runs in the Validation Database	3

## EXECUTIVE SUMMARY

A brief investigation was conducted on the effect of the number of time steps used by the ice accretion code LEWICE 2.0 in determining an ice shape. The investigation began with a review of information in the user's manual and validation report and included a study of the LEWICE 2.0 validation database and approximately 30 additional LEWICE 2.0 runs.

For more than 90 percent of LEWICE 2.0 cases in the validation database, the number of time steps used in calculating the ice shape was different from the "default" number of time steps determined by LEWICE 2.0 with the automatic time-stepping feature on. In all these cases, the number of time steps was equal to the IFLO input value, which was determined in accordance with a "minutes rule." It is recommended that the minutes rule be incorporated into LEWICE 2.0 so that the default number of time steps determined by LEWICE 2.0 is consistent with the number of time steps used for the runs in the validation database. The accuracy of LEWICE 2.0 when using the current default number is not documented in the validation database.

It was also determined that the accuracy of LEWICE 2.0 ice shapes does not improve when the number of time steps is increased beyond a certain value. Specifically, when the number of time steps is increased beyond about 25 or 30, depending on the conditions, the ice shape predictions tend to diverge, and the upper horn (if present) tends to "droop." It is recommended that the user be warned against inputting too large a number of time steps.

## 1. INTRODUCTION.

This report describes a brief investigation of questions concerning the number of time steps used by LEWICE in determining an ice shape. (All references to LEWICE in this report are to LEWICE 2.0.) The investigation began with a review of the information provided in the user's manual [1] and validation report [2]. It builds upon and extends the results reported there. Approximately 30 additional LEWICE runs were made for this investigation.

## 2. DETERMINATION OF NUMBER OF TIME STEPS.

The determination of the number of time steps used in the ice shape calculation is discussed on pages 13-17 of the user's manual [1]. The key points are summarized here. Strictly for the purposes of discussion in this report, a variable  $N\_STEPS$  is introduced. (The italics are used to distinguish it from LEWICE variables.)  $N\_STEPS$  is defined as the number of time steps actually used by LEWICE in the determination of an ice shape.

Three LEWICE variables, IFLO, N, and ITIMFL, are involved in the determination of  $N\_STEPS$ .

- IFLO = A variable input by the user as a candidate value for  $N\_STEPS$ .
- N = A variable calculated by LEWICE as a candidate value for  $N\_STEPS$ .

The formula used by LEWICE to calculate N is

$$N = \frac{(LWC)(V)TIME}{(chord)(\rho_{ice})(0.01)} = 100 \times A_c \quad (1)$$

where

LWC = liquid water content ( $g/m^3$ )

V = Velocity (m/s)

Time = Accretion time (s)

Chord = Airfoil chord (m)

$\rho_{ice}$  = ice density =  $9.17 \times 10^5$   $g/m^3$

$A_c$  = Accumulation parameter

- ITIMFL = a flag which functions as follows:

If ITIMFL = 1 (i.e., "automatic time stepping" on) and

- IFLO  $\geq$  N, then  $N\_STEPS$  = IFLO.
- IFLO < N, then  $N\_STEPS$  = N and the user receives the following warning:

"The input number of time steps (IFLO) has been changed to the calculated value of (N). Unless otherwise noted, this occurred because the auto-time stamp ITIMFL is set = 1."

If  $ITIMFL = 0$  (i.e., “automatic time stepping” off)

– then  $N\_STEPS = IFLO$  and the user receives the following warning:

“You are not using automated time stepping procedure. The accuracy of the code in this situation is unknown.”

Note: LEWICE calculates  $N$  no matter what the value of  $ITIMFL$ . If  $ITIMFL = 0$  and  $IFLO < N$ , an additional warning is issued:

“You are using fewer time steps than recommended. Number of time steps recommended = (value). Number of time steps selected = (value). Ice shapes produced may be different from those used to validate this code.”

As noted, the user can be said to be using the “automatic time step procedure” if  $ITIMFL = 1$ . This simply means that  $N\_STEPS =$  the larger of  $IFLO$  and  $N$ .

(Note: The user can input the value of  $ITIMFL$  from the LEW20 namelist in the input file. If  $ITIMFL$  is omitted from the namelist, LEWICE sets  $ITIMFL = 1$ , i.e., this is the “default” value.)

The effect of the number of time steps used in the ice shape calculation is discussed on page 9 of the validation report [2]. It is stated that the “automated time step procedure” was used, which means that  $N\_STEPS =$  the larger of  $IFLO$  and  $N$  for all runs in the validation database. Based on a private communication [3] from the primary author of the validation report, it was learned that the  $IFLO$  input value was determined in accordance with the following “minutes rule”:

- Let  $MINUTES$  = the total time in minutes of the icing event being simulated. (Once more, the italics are used to distinguish this variable from LEWICE variables. Note also that  $MINUTES = TSTOP/60$ , where  $TSTOP$  is the LEWICE variable defined as the total time of the icing simulation in seconds.)
- If  $MINUTES < 15$  minutes,  $IFLO = MINUTES$ .
- If  $MINUTES \geq 15$  minutes,  $IFLO = 15$ .

Table 1 is based upon an examination of the validation database.  $N$  is calculated from the appropriate variables in the database using equation 1, and  $IFLO$  is determined in accordance with the minutes rule. The table shows that for 208 out of 230 cases, or 90.4 percent,  $N$  is smaller than  $IFLO$ , so that the LEWICE ice shape was calculated using  $IFLO$ , the number of time steps based on the minutes rule, rather than using  $N$ , the default number of time steps determined internally by LEWICE.

TABLE 1. COMPARISON OF VALUES OF N AND IFLO FOR LEWICE RUNS IN THE VALIDATION DATABASE

	N < IFLO	N = IFLO	N > IFLO	Total
Spray Time < 15 min.	164	4	14	182
Spray Time ≥ 15 min.	44	0	4	48
Total	208	4	18	230

Note: It is recommended that the minutes rule be incorporated into LEWICE 2.0 so that the default number of time steps determined by LEWICE 2.0 is consistent with the number of time steps used for the runs in the validation database. The accuracy of LEWICE 2.0 when using the current default number is not documented in the validation database.

### 3. EFFECT OF NUMBER OF TIME STEPS.

The validation report [2] states on page 9: "An additional 18 runs were made to illustrate the variation when different time steps are used." (These are "in addition" to the runs included in the validation database.) The results are discussed briefly, with results shown in figures 42-59 of reference 2. Three cases (see figures 42-51 of reference 2) were selected for further investigation in the present study. The authors reran two of the cases to verify that they were obtaining the same results presented in reference 2. These results are shown in figures 1 and 2.

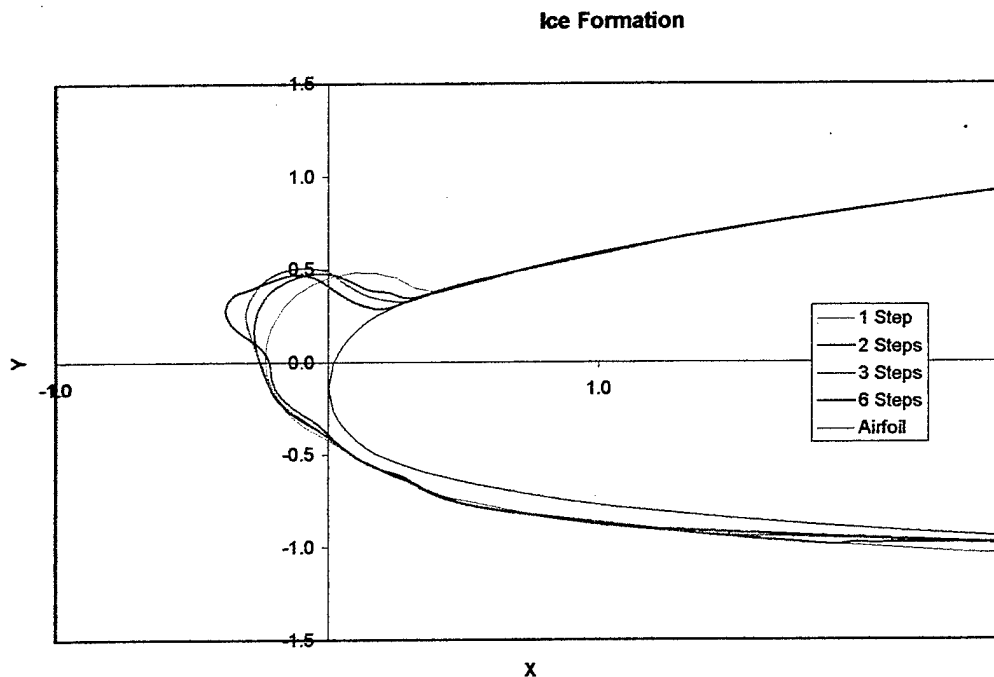

FIGURE 1. RUN 072501

### Composite Ice Formation

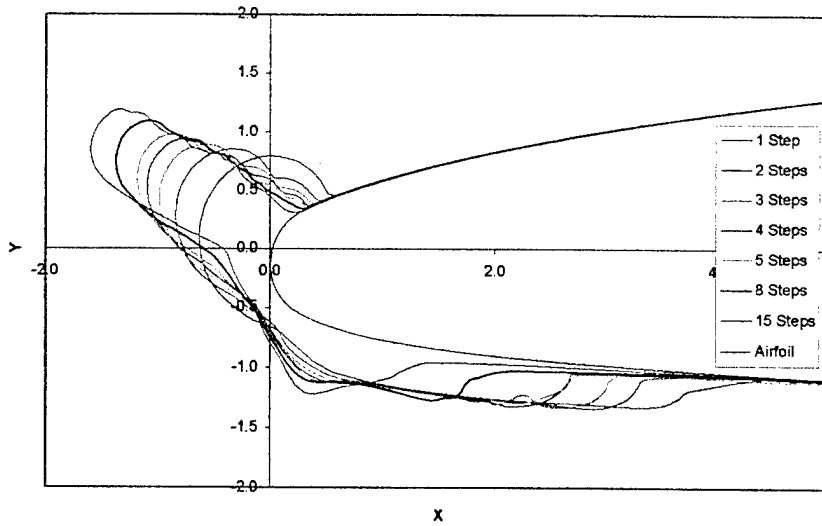

FIGURE 2. RUN 072503

The results from figures 1 and 2 match those in reference 2 and are consistent with the statement in reference 2 that “these cases show a large variation in ice shape prediction due to time step, *although the variation decreases as the number of time steps increases.*” (Italics added.) However, it is not clear that the ice shapes are converging to a “limit shape” as the number of time steps increases, therefore, the same conditions were run with more time steps for this study. The results for these runs are shown in figures 3 and 4.

### Ice Formation

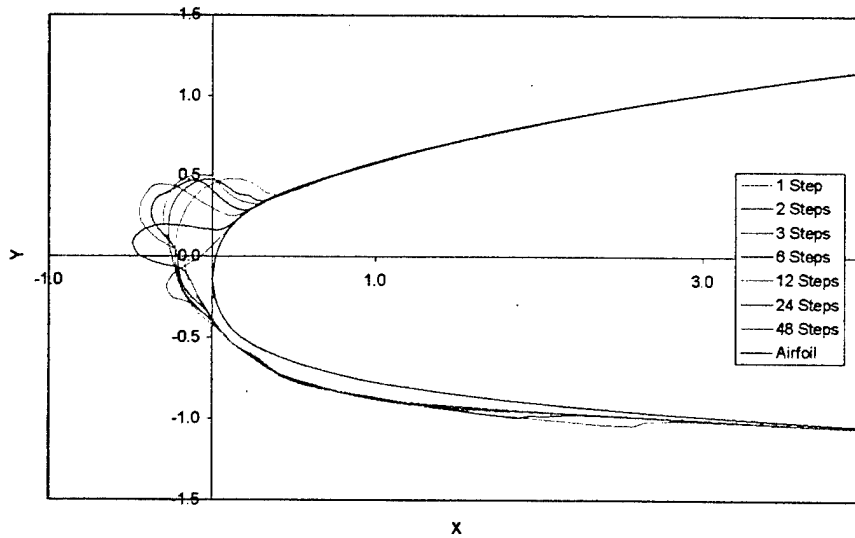

FIGURE 3. RUN 072501 WITH ADDITIONAL TIME STEPS

### Composite Ice Formation

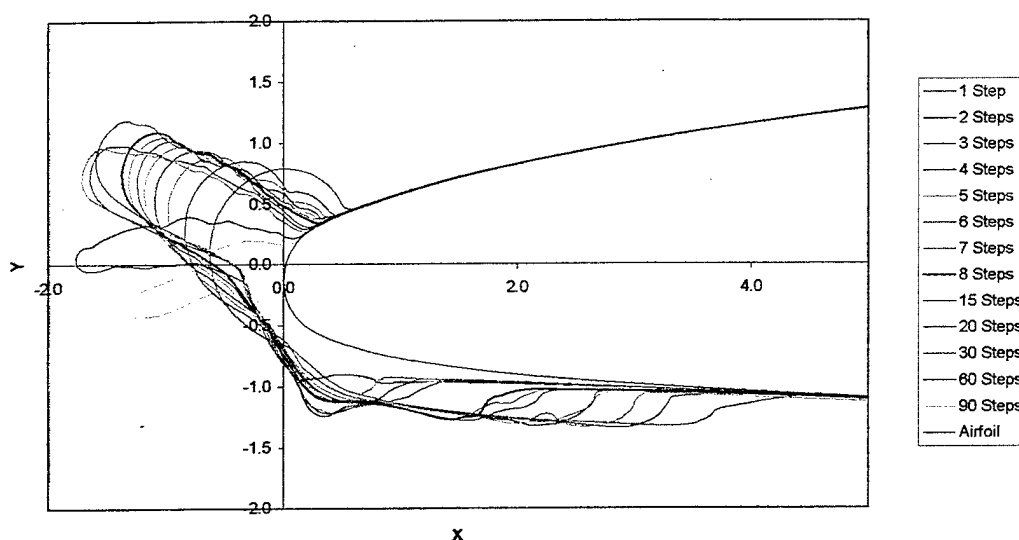

FIGURE 4. RUN 072503 WITH ADDITIONAL TIME STEPS

Figure 3 shows the final ice shape for runs made with 1, 2, 3, 6, 12, 24, and 48 time steps. Figure 42 in the validation report [2] stops with 6 time steps. ( $N\_STEPS = 6$  for the ice shape included in the validation database; LEWICE calculated  $N = 2$ .) At 6 time steps, the “upper horn” is just starting to “droop” but is still substantially the same as the ice shapes produced by fewer time steps. However, beyond 6 time steps, the upper horn migrates downward on the airfoil until its location can no longer be described as upper.

Note that with a spray time of 6 minutes and 24 iterations, each time step is 15 seconds long. Using 48 iterations gives time steps of only 7.5 seconds each.

Figure 4 shows the final ice shape for runs made with 1, 2, 3, 4, 5, 6, 7, 8, 15, 20, 30, 60, and 90 time steps. The validation report [2] stopped with 15 time steps. ( $N\_STEPS = 7$  for the ice shape included in the validation database; LEWICE calculated  $N = 7$ .) Runs made with 3 through 15 time steps seem to be converging to a “limit shape.” However, they differ from runs made with 1 or 2 time steps and runs made with more than 15 time steps.

Note that with a spray time of 22.5 minutes and 90 iterations, each time step is 15 seconds long.

At 20 time steps, the upper horn droop begins to be apparent; by 60 time steps the upper horn is almost horizontal.

In addition to the effects on the upper-horn shape, the lower shape shows marked changes as well. At low numbers of time steps, it is not a well-defined horn, but rather more like a step. For the higher numbers of time steps, it converges to a shape more resembling a horn, but its position shifts.

As can be seen from figures 3 and 4, not only do the shapes not necessarily converge to a limit shape with increasing numbers of time steps, but there appears to be a tendency for the shapes to diverge, resulting in ice shapes decidedly different from the shapes included in the validation database. The apparent tendency of the upper horn to droop with a large number of time steps, could sometimes result in an ice shape that would cause a smaller aerodynamic penalty.

As a result of these tests, it was decided to conduct additional time step tests for tunnel runs 1-23-run8 (figure 5), 125 (figure 6), and 231 (figure 7). (These cases were not included among the time step tests presented in reference 2.) Tunnel run 1-23-run8 was selected based on lack of agreement between the predicted and experimental upper-surface peak thickness. Tunnel run 125 was selected because it had the greatest upper-surface peak thickness, and tunnel run 231 was also selected because it had the smallest upper-surface peak thickness.

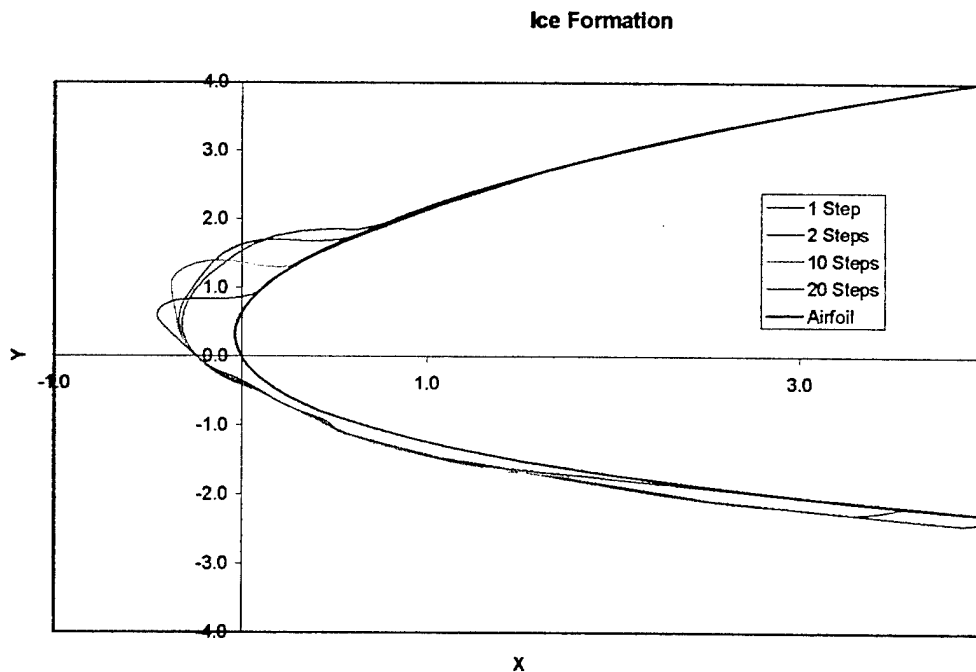

FIGURE 5. TIME STEP TESTS FOR RUN 1-23-RUN8

Ice Formation

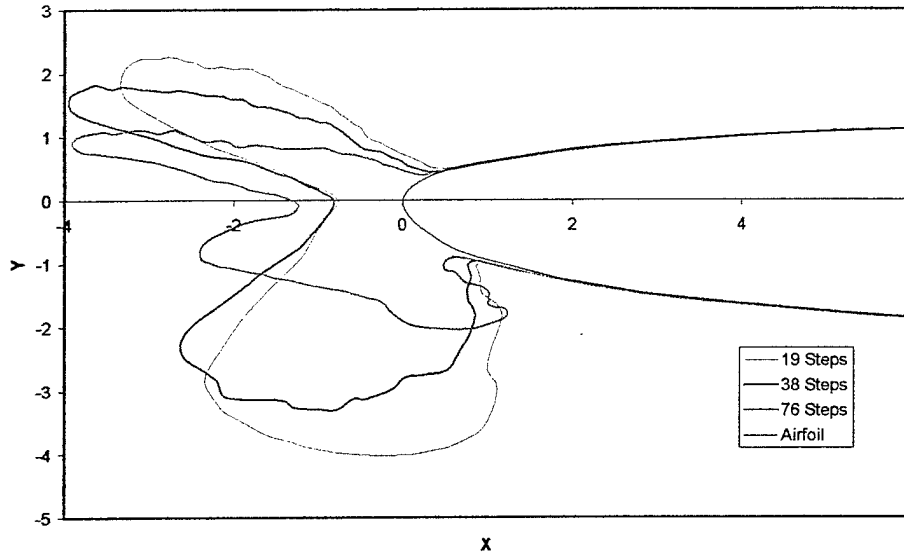

FIGURE 6. TIME STEP TESTS FOR RUN 125

Ice Formation

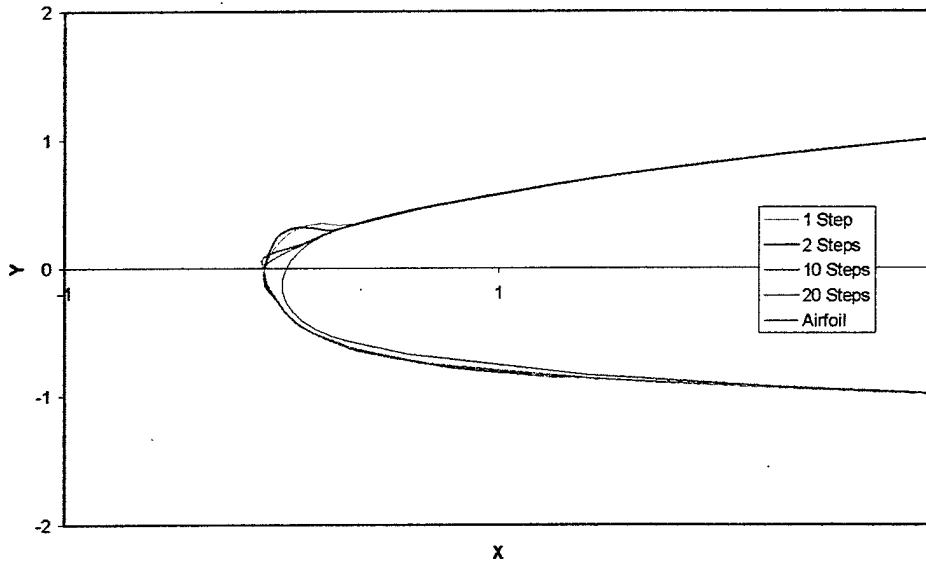

FIGURE 7. TIME STEP TESTS FOR RUN 231

These results are consistent with the earlier results shown in figures 3 and 4. The reasons for this behavior are beyond the scope of this report.

Note: Based on the results in this section, it is recommended that the LEWICE 2.0 user be warned against inputting too large a number of time steps.

#### 4. RECOMMENDATIONS.

Two recommendations, already stated above, result from this study:

1. It is recommended that the minutes rule be incorporated into LEWICE 2.0 so that the default number of time steps, determined by LEWICE 2.0, is consistent with the number of time steps used for the runs in the validation database. The accuracy of LEWICE 2.0 when using the current default number is not documented in the validation database.
2. LEWICE 2.0 does not currently warn against using too many time steps. Based on the results in section 3, it is recommended that the user be warned against inputting too large a number of time steps.

#### 5. REFERENCES.

1. Wright, W., "User Manual for the NASA Glenn Ice Accretion Code LEWICE Version 2.0," NASA/CR – 1999-209409, September 1999.
2. Wright, W. and Rutkowski, A., "Validation Results for LEWICE 2.0," NASA/CR – 1999-208690, January 1999.
3. Wright, W., private communications, NASA Glenn Research Center, Cleveland, Ohio, February 2000.