



NRL/MR/6180--02-8631

Wireless Communication Technologies on ex-USS *Shadwell*

THOMAS T. STREET
XUAN NGUYEN
FREDERICK W. WILLIAMS

*Navy Technology Center for Safety and Survivability
Chemistry Division*

July 31, 2002

20020904 008

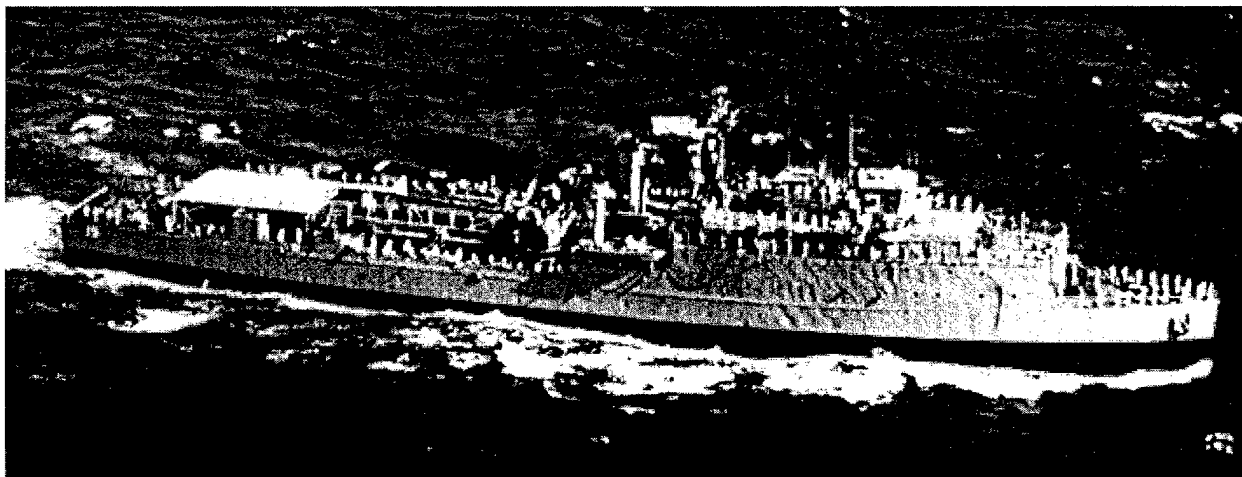

Approved for public release; distribution is unlimited.

REPORT DOCUMENTATION PAGE

Form Approved
OMB No. 0704-0188

Public reporting burden for this collection of information is estimated to average 1 hour per response, including the time for reviewing instructions, searching existing data sources, gathering and maintaining the data needed, and completing and reviewing this collection of information. Send comments regarding this burden estimate or any other aspect of this collection of information, including suggestions for reducing this burden to Department of Defense, Washington Headquarters Services, Directorate for Information Operations and Reports (0704-0188), 1215 Jefferson Davis Highway, Suite 1204, Arlington, VA 22202-4302. Respondents should be aware that notwithstanding any other provision of law, no person shall be subject to any penalty for failing to comply with a collection of information if it does not display a currently valid OMB control number. **PLEASE DO NOT RETURN YOUR FORM TO THE ABOVE ADDRESS.**

1. REPORT DATE (DD-MM-YYYY) July 31, 2002		2. REPORT TYPE		3. DATES COVERED (From - To) January 1992-September 2002	
4. TITLE AND SUBTITLE Wireless Communication Technologies on ex-USS <i>Shadwell</i>				5a. CONTRACT NUMBER N00014-97-C-2064/N00014-99-C-0033	
				5b. GRANT NUMBER	
				5c. PROGRAM ELEMENT NUMBER 603123N	
6. AUTHOR(S) Thomas T. Street, Xuan Nguyen, and Frederick W. Williams				5d. PROJECT NUMBER	
				5e. TASK NUMBER	
				5f. WORK UNIT NUMBER 61-8244-0-2-5	
7. PERFORMING ORGANIZATION NAME(S) AND ADDRESS(ES) Naval Research Laboratory, Code 6180 4555 Overlook Avenue, SW Washington, DC 20375-5320				8. PERFORMING ORGANIZATION REPORT NUMBER NRL/MR/6180--02-8631	
9. SPONSORING / MONITORING AGENCY NAME(S) AND ADDRESS(ES) Office of Naval Research 800 North Quincy Street Arlington, VA 22217				10. SPONSOR / MONITOR'S ACRONYM(S)	
				11. SPONSOR / MONITOR'S REPORT NUMBER(S)	
12. DISTRIBUTION / AVAILABILITY STATEMENT Approved for public release; distribution is unlimited.					
13. SUPPLEMENTARY NOTES					
14. ABSTRACT "Wireless Communication Technologies" is a description of three state-of-the art, wireless communication systems that were installed and demonstrated on the ex-USS <i>Shadwell</i> , the Navy's full-scale test facility in Mobile, Alabama. The MicroLan RF Tag and RSVP demonstration systems were developed for DARPA and the Office of Naval Research (ONR) Advanced Technology Demonstrators (ATD's) under Navy Contract N00014-97-C-2064 and N00014-99-C-0033, respectively.					
15. SUBJECT TERMS Wireless; MicroLan; RSVP; DC-ARM; Consolidated antenna systems; Access points; RF Tag Communication System; Broad area announcement					
16. SECURITY CLASSIFICATION OF:			17. LIMITATION OF ABSTRACT UL	18. NUMBER OF PAGES 75	19a. NAME OF RESPONSIBLE PERSON Frederick W. Williams
a. REPORT Unclassified	b. ABSTRACT Unclassified	c. THIS PAGE Unclassified			19b. TELEPHONE NUMBER (include area code) 202-767-2002/767-2476

CONTENTS

1.0 INTRODUCTION.....	1
2.0 DAMAGE CONTROL WIREFREE COMMUNICATIONS	2
2.1 System Description	2
2.2 Maintenance	2
2.3 Protected Voice Portable Communication System	3
2.3.1 The PVPCS System Equipment.....	3
2.3.2 Antenna Network Components.....	7
2.4 Operational Deficiencies and Issues	10
3.0 THE LUCENT ROBUST RF TAG MICROLAN COMMUNICATION SYSTEM.....	11
3.1 The RF Tag	11
3.2 The Personnel Status Monitor.....	14
3.3 Wireless Environmental Sensors	14
3.4 The Wireless Interrogator	17
3.5 Information Collection and Delivery (IC&D).....	17
3.6 Graphic User Interface (GUI)	24
4.0 REDUCED SHIP'S CREW BY VIRTUAL PRESENCE (RSVP) ADVANCED TECHNOLOGY DEMONSTATION (ATD).....	24
4.1 Intelligent Component Health Monitors (ICHM)	31
4.2 Environmental Sensor Clusters.....	35
4.3 Personal Status Monitors	36
4.4 Information Exchange and Display.....	36
5.0 REFERENCES	45
6.0 DEFINITIONS OF ABBREVIATIONS	46
APPENDIX A - WIRELESS RF TAG (MICROLAN) POWER-UP AND OPERATION PROCEDURE	
APPENDIX B - Ex-USS <i>Shadwell</i> WIFCOM RADIAX ANTENNA CABLE ROUTING DIAGRAMS	

Wireless Communication Technologies on ex-USS *Shadwell*

1.0 INTRODUCTION

The ex-USS *Shadwell* [1] supports the development of ship systems which reduce the manning requirements for future ships. Wireless communications offer a number of benefits for shipboard operations and supports the shipboard automation concept in many ways. The flexibility resulting from having a communications connection available anywhere in the covered spaces of a ship provides enhanced connectivity (the connection is always there), enhanced mobility (not tied to a wired connection), more tolerance to damage (less physical connections) and a reduced fire load due to reduced cabling. Thus, wireless communication used in support of enhanced safety and survivability of naval platforms is an area to be investigated and demonstrated. A particular need exists for low-cost sensor data communications. It has been shown that wireless communications will support this need. Currently, to run a cable to a sensor on board a ship can cost \$5,000. A low cost wireless infrastructure for data communications to and from sensors may be able to reduce this cost by more than a factor of 100 on a per channel basis. This will offer a more extensive use of sensors than is currently affordable. Enabling the cost-effective collection of data is critical to providing the information needed to carry out remote monitoring of spaces on a ship. The use of wireless communications enables the flexible placement of sensors since a data connection is available everywhere. This concept lends itself to the support of mobile sensors such as personnel badges or personnel status monitors to monitor the physiological state of individual crew members. Such a system directly supports damage control automation for reduced manning by replacing the human as a multi-sensor, information processor, actuating and communicating entity with a system which carries out these functions.

Three systems which use wireless communications to facilitate the collection, transfer and display of data and which are currently installed and operational on the ex-USS *Shadwell* are; (1) Wirefree Communications (WIFCOM), (2) The Lucent Robust RF Tag Microlan Communications System for Shipboard Damage Control Automation, procured for DARPA as an Advanced Technology Demonstration (ATD) under Navy Contract N00014-97-C-2064 [2] and (3) Reduced Ships-Crew By Virtual Presence (RSVP) procured as an ATD on Navy Contract N00014-99-C-0033 [3]. This report details these systems separately in an attempt to allow the reader to understand their operation, capabilities and differences, and most importantly to understand the potential of wireless communication systems in shipboard environments.

2.0 DAMAGE CONTROL WIREFREE COMMUNICATIONS (DC WIFCOM) AN/SRC-53(V)

2.1 System Description

The Damage Control Wirefree Communications (DC WIFCOM) System is a non-developmental item (NDI) radio system which is designed to augment existing interior communications (IC) sound powered circuits used for damage control (DC). Equipment redundancy is provided in the system design to enhance operational survivability. Major equipment components for DC WIFCOM are manufactured by Motorola Communications and Electronics Inc and procured from them under government contract. The WIFCOM system is composed of commercial off-the-shelf equipment and requires a high degree of Integrated Logistic Support (ILS). The WIFCOM system installed on the ex-USS *Shadwell* was certified operational on 06/04/1992 and was calibrated on 10/10/1992. The *Shadwell* WIFCOM system consists of WIFCOM electrical equipment cabinets located in each repair locker which house the base station RF amplifiers, a 13.8 VDC Power Supply, receiver-transmitter portable radios equipped with speaker microphones, battery conditioner/chargers for NiCad and Gel Cell batteries and spare NiCad and Gel Cell batteries. RADIAX antenna cable is routed throughout the covered ship spaces between repair lockers to aid in the transmission and reception of WIFCOM communications. The routing of the cable on *Shadwell* is shown in Appendix B. The RADIAX (AS-3980) cable is a slotted coaxial cable that is a combination transmission line and antenna for DC WIFCOM communications. Slots in the corrugated copper outer conductor allow a controlled portion of the transmitted RF signal to radiate from the cable along its entire length and couples into the cable signals transmitted near the cable by coupling the signals into the slots allowing the cable to carry the signals to its destination along the cable. Five watt WIFCOM portable radios operating on specific assigned channels within the 450 - 470 MHz band and roaming within the covered ship boundaries can communicate with base stations and other portable radios operating on these same channels aided by the RADIAX cable. Each portable radio in the system is equipped with a Digital Private Line (DPL) code which is unique to each ship. The DPL code reduces the likelihood of interference or crosstalk between radios on different ships operating on the same frequency. All radios for the small ship program are capable of operating on any of four channels. Channel 1 - 3 are assigned to individual repair zones. Channel four is used exclusively for ship to ship DC coordination.

2.2 Maintenance

Organizational level maintenance (0 - Level) is accomplished by shipboard technicians for a Periodic Maintenance Schedule (PMS) which has been developed for DC WIFCOM. This maintenance consists of visual and operational checks of system portable radios, base stations, batteries, battery conditioners and chargers, spare equipment and the RADIAX antenna. Maintenance and conditioning of the transceiver batteries is accomplished on an on-going basis to assure system operational effectiveness. Corrective maintenance at the 0 - Level is limited to replacement of broken radio antennas, conditioning of operational unit batteries and replacement

of defective transceiver NiCad battery packs and control knobs. All other repair is to be accomplished by an authorized repair station.

2.3 Protected Voice Portable Communication System PVPCS/DC WIFCOM Consolidated Antenna System Upgrade

Installation of the Protected Voice Portable Communication System (PVPCS) Consolidated Antenna System (CAS) was accomplished in 1996 as a modification to the DC WIFCOM system to improve the system effectiveness by reducing communication "dead spots" caused by multipath and poor RF coverage. The PVPCS shipwide antenna system is configured to accommodate up to eight additional radio systems (networks) in the 450 to 470 MHz band. The antenna system provides interior radio communications for the ship, Figure 1. Communications from anywhere on the ship is usually possible. No external antennas are to be connected to the PVPCS antenna system since external communication is not allowed in the 450 to 470 MHz band. The extensive layout of the PVPCS interior antenna provides two-way radio communications between handheld transceivers throughout at least 80%, and often almost 100% of the ship. The interior antennas may be expanded for additional coverage, but strict engineering guidelines must be followed. Appendix "B" details the modified antenna system's route through the ship's compartments and pointing out antenna system components and their location. The MK 2 MOD 0 combiner couples the various networks (nets) onto the ship wide interior antenna. The addition of a new net (WIFCOM) in the 450 to 470 MHz band requires another repeater plus and expansion module for the combiner. Also, there are other optional features which can easily be added to accommodate any special requirements of each ship, such as telephone links, ship to shore links, multiple system hand-held transceivers, trunked radio systems, base station units and paging systems. The installation was handled by *Shadwell* ship's force and personnel from the Naval Ordnance Station Louisville, KY. The PVPCS repeater and combiner equipment rack was installed in the old "Bakery" space and a 120 VAC, 15 A, 60 Hz service was installed providing electrical power, Figure 2 & 3. In addition to reinstalling most of the RADIAX cable supporting DC WIFCOM's initial installation, a repeater/combiner, antenna terminations, RTL/Connectors, RF splitters, a 10 db taps and a CAS filter were installed. The previously installed and new cables were also tagged and banded to facilitate identification of cabling in the future. The CAS system was designed to utilize existing cableways and previously installed cable to the maximum extent possible to cut down on the installation of new cables. The CAS is designed to provide better overall RF coverage from all locations whether receiving or transmitting. Improvements in coverage was aided by the rerouting and/or adding of RADIAX cabling and adjusting transmit power levels to obtain receive db levels required for good, reliable communications in all ship areas. The PVPCS was installed and tested and accepted on 27 March 1996.

2.3.1 The PVPCS System Equipment

The major PVPCS equipment is separated into three (3) categories: (1) Portable UHF Transceiver and Accessories, (2) Antenna System and (3) Support Equipment. The UHF Transceiver and Accessories consists of portable transceivers, remote speaker microphones,

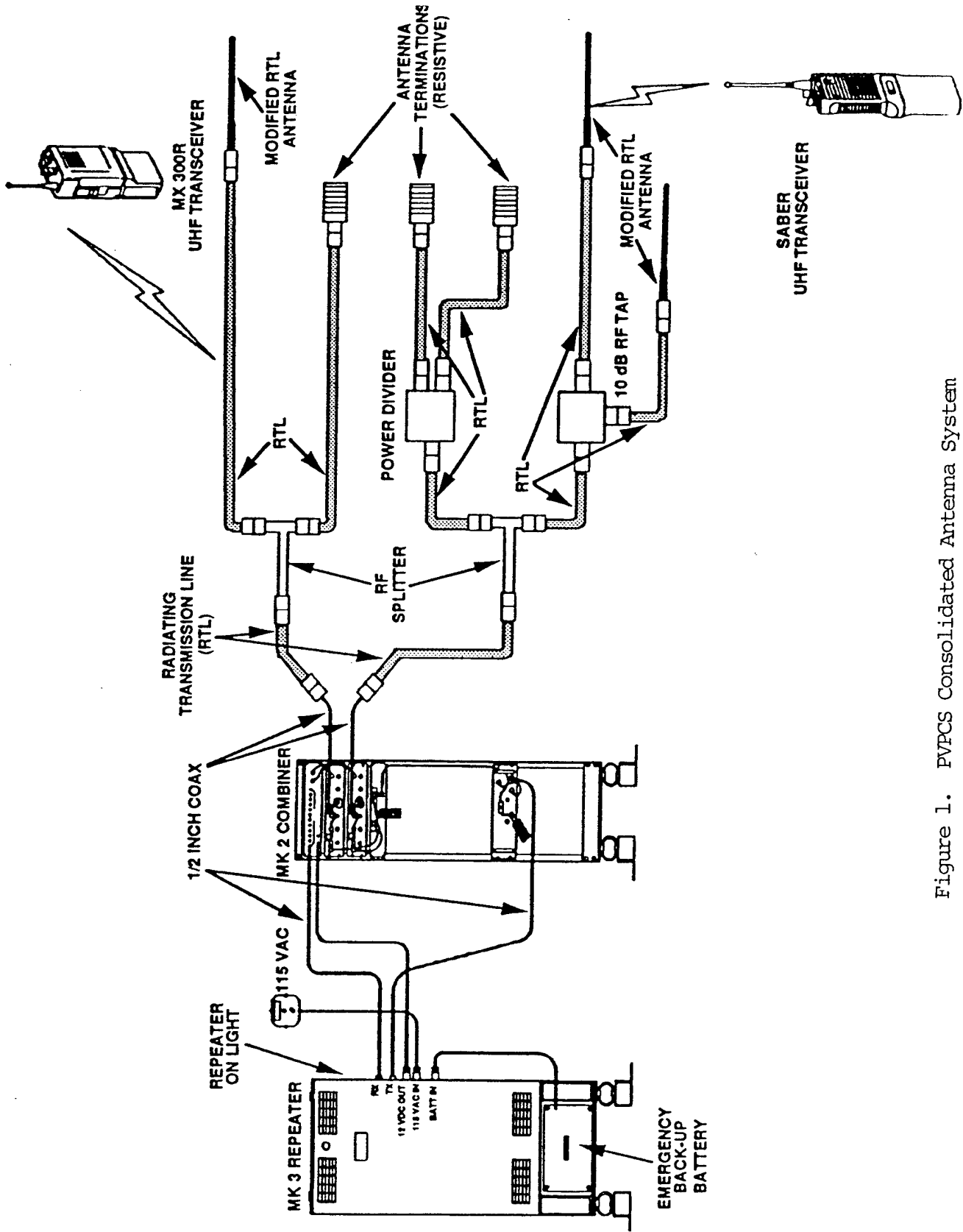

Figure 1. PVPCS Consolidated Antenna System

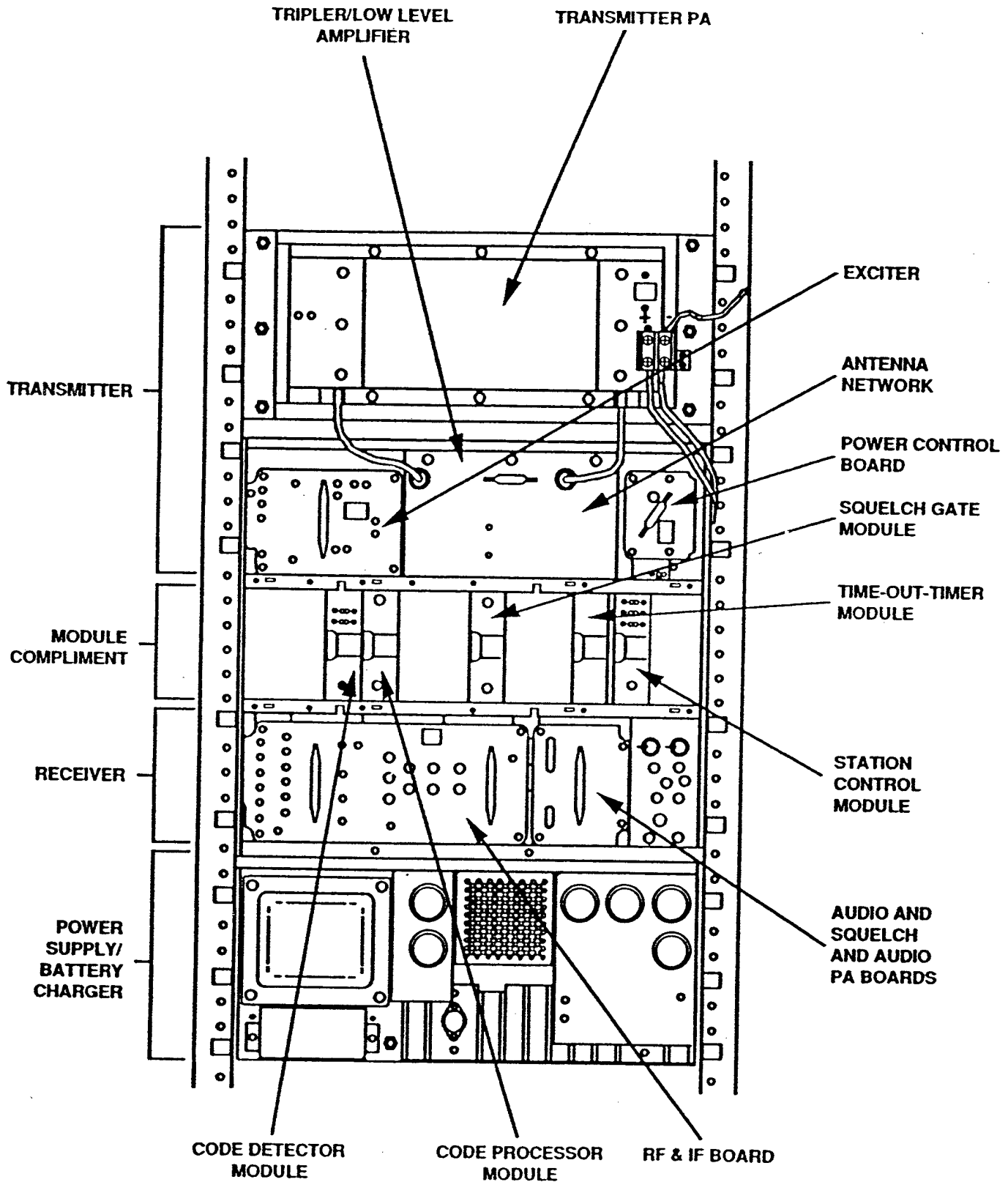

Figure 2. PVPCS Repeater

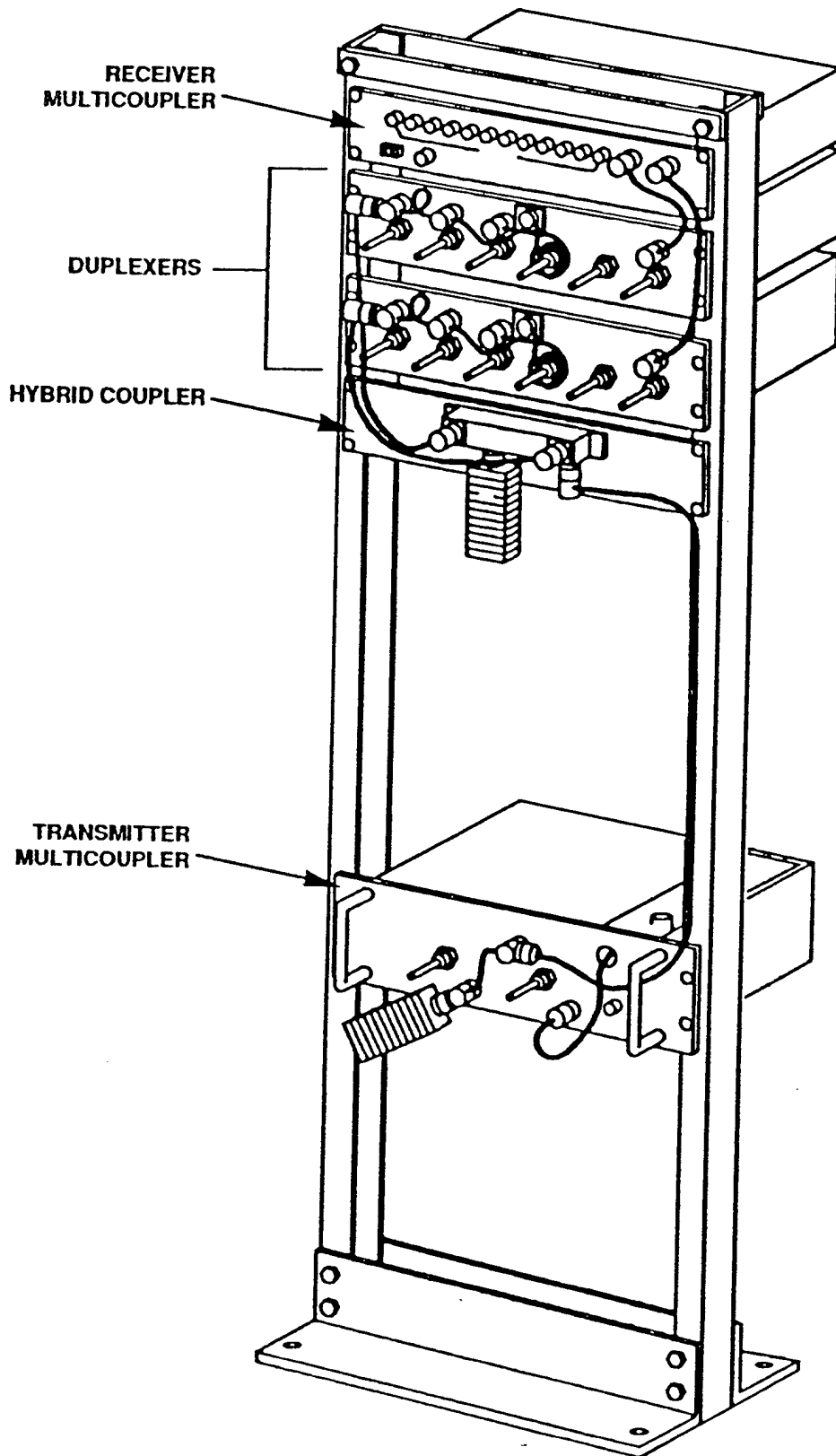

Figure 3. PVPCS Combined

batteries, a chest harness (not used on *Shadwell*) and a belt holster. The antenna system employs a combiner, repeater and an antenna network which includes radiating transmission lines, RF splitters, power dividers, 10db RF taps and antenna terminations. The support equipment consists of an encrypted key loader to insert an encryption code into the transceivers for voice security (if used) and a battery conditioner (charger/discharger) for determining the ampere-hour capacity of the transceiver batteries. The conditioner features an approved one-hour rapid charge system and a constant current discharge system. The conditioner is a multiple unit designed to recharge and maintain full capacity for a minimum of six (6) portable transceiver batteries. Components of the system (see Figure 4) are;

- A. Remote Speaker Microphone (RSM) - The RSM consists of a speaker, microphone, press-to-talk switch in one unit, with an attaching clip. The RSM attaches to the UHF transceiver by a single connector. The transceivers internal speaker and microphone are disabled when the RSM is attached.
- B. Battery - A rechargeable 7.5 volt nickel-cadium battery is supplied with each transceiver. It can be recharged in one hour.
- C. Chest Harness - Securely attaches the UHF transceiver to the torso of the operator in the proximity of the upper chest. The chest harness is not used on *Shadwell*.
- D. Belt Holster - Securely attaches the UHF transceiver to the operators waist belt.

2.3.2 Antenna Network Components:

- A. The antenna system employs a combiner, repeater and an antenna network which includes a radiating transmission line (RTL), RF splitters, power dividers, 10 db RF taps and antenna terminations, see Figure 5. The Radiating Transmission Line (RTL) is a slotted coaxial cable designed to receive and/or radiate (leak) RF signals. A back-up battery provides power for the repeater and combiner when AC power is interrupted.
- B. RF Splitter - The RF splitter is used in conjunction with the RTL to equally divide RF signals while maintaining a 50 ohm impedance. Splitter has two non-isolated output ports.
- C. Power Divider - The power divider is used in conjunction with the RTL to equally divide RF signals while maintaining 50 ohm impedance. The three RF ports are interchangeable as inputs and outputs.
- D. RF Taps - The 10db RF tap is used where equal power division is not desired.

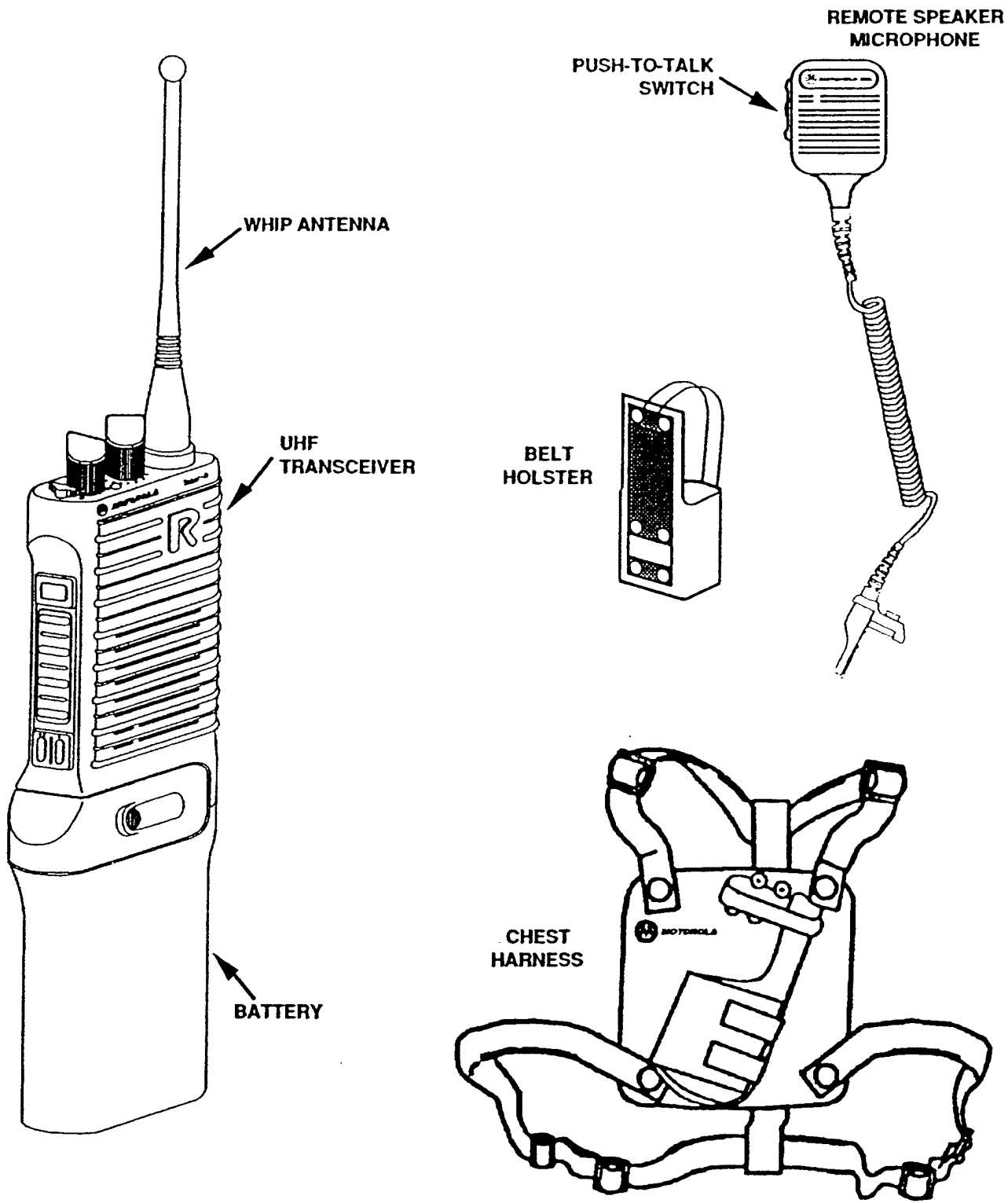

Figure 4. Portable Transceiver Radio Components

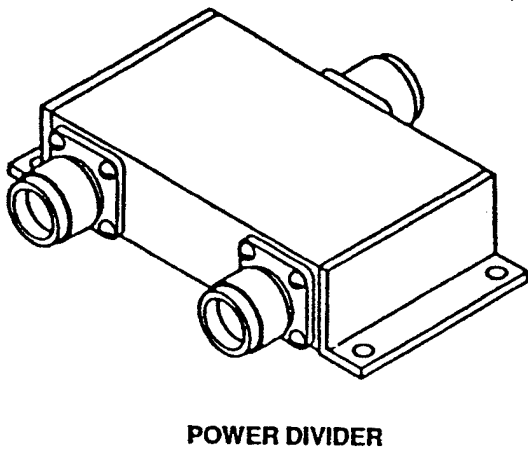
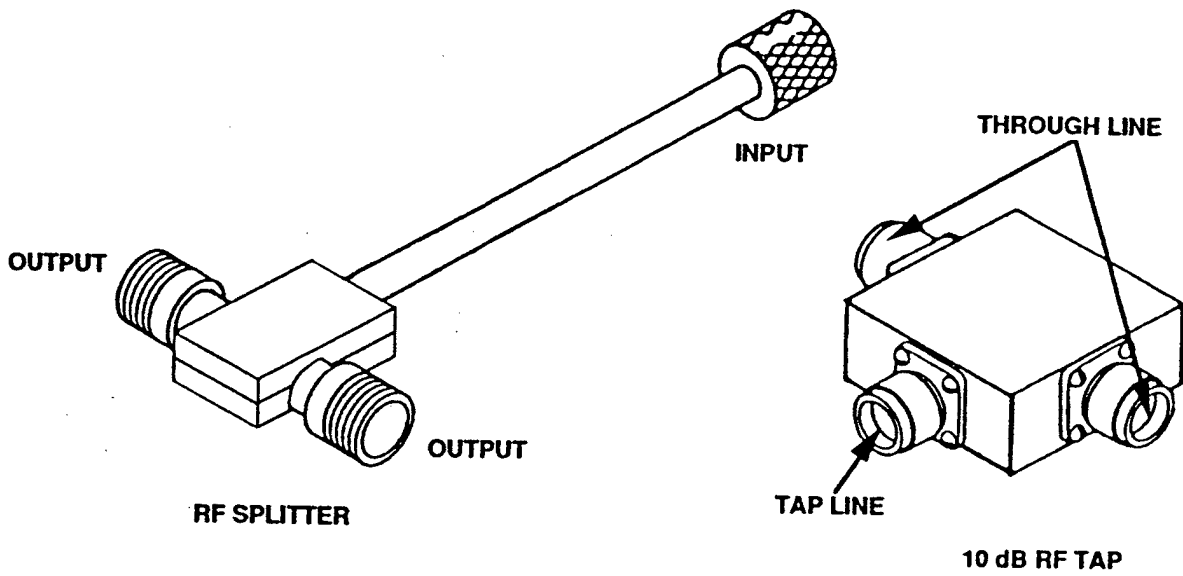
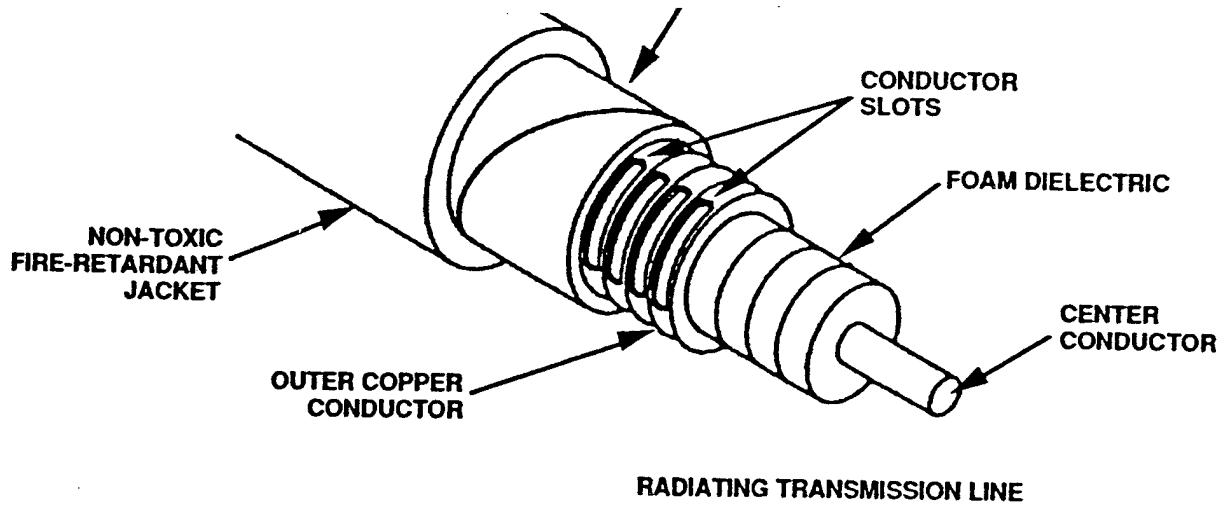

Figure 5. CAS Antenna Components

- E. Antenna Termination - There are two types of antenna terminations. The first is a 50 ohm resistive type and the second is a modified RTL. The preferred type is the modified RTL which forms a UHF/VHF antenna.

2.4 Operational Deficiencies And Issues

A pattern of intermittent operation of the DC WIFCOM system has been observed during normal ship operations in support of tests, advanced technology demonstrations and research and development operations. Difficulties have been attributed to numerous perceived and real equipment and user problems, the presence of smoke and water mist during DC operations. Operational tests to determine system status, using known good equipment from a ship location, have shown perfect communications operations one day and no communications operations when repeated the next day. Because of the enormous potential for changes to the operational characteristics of the system such as environment, equipment, door closures, user errors and system operational characteristics it is difficult to isolate the intermittent operation to any one cause. The RADIAX antenna cable is supposed to pick up the signal from isolated ship locations and transfer the signals wherever the cable transits ship compartments. This does not seem to be always be the case. In the case of good communications one day and bad communications the next day, the problem appears suspiciously like multipath interference caused by the location of the transmitter in the compartment. If this is the case, then simply having the transmitter operator move to a different location within the compartment should immediately improve communications. Single frequency transmission schemes, such as walky-talkies are not a good match for steel ship compartments because of the possibility of attenuation of the transmission signal due to multipath interference. In addition, the ability of the RADIAX cable to pickup the signals in isolated ship compartments where multipath is present may also be questionable.

Since it is unclear by which means the DC WIFCOM communications on *Shadwell* are being interrupted, the acquisition of some test equipment to determine the power output levels and receiver sensitivities of the transceivers is a reasonable first step. Numerous RADIAX cable connections in the aft wing wall on *Shadwell* have been found to be defective due to the connector pins in the cable that were not soldered. Reception problems have also been identified in the 2nd deck starboard passageway. The RADIAX cable in the identified problem areas should be carefully inspected for damage, the connectors examined and RF power readings taken to determine the RF coverage. The transceivers should be tested to determine the power output levels and the receiver sensitivity.

3.0 THE LUCENT ROBUST RF TAG MICROLAN COMMUNICATION SYSTEM (LUCENT MICROLAN)

This system was procured for DARPA as an advanced technology demonstration of a wireless communications system supporting the (a) location of personnel, (b) monitoring of their physiological state, and (c) the monitoring of the environment, Fig 6. This system consists of a wireless RF infrastructure, based on RF Tag technology, servers to store, manipulate and retrieve environmental and personnel status data, personnel status monitors, wireless environmental sensors and a graphic user interface (GUI) to display information in a user friendly manor. This system directly supports the Damage Control Automation for Reduced Manning (DC ARM) concept by replacing the human as a multi-sensor, information processor, actuator and communicating entity with a system that carries out these functions. Communication between the RF interrogators, servers and display can be 10/100 ethernet provided by either a wired or wireless local area network (LAN) connection, such as the WaveLan system installed on the ex-USS *Shadwell*. [4]

3.1 The RF Tag

The RF tags used in the Lucent MicroLan system are passive devices and do not contain a transmitter. Each RF Tag has a unique identifier and will respond upon receiving its identifier sequence. RF interrogators broadcast a coded RF request sequence (tag identifier) followed by a short unmodulated signal (where the tag downloads its information). The tag responds by changing (modulating) the impedance of its antenna, thereby modulating the frequency (paradigm shift) of its reflected backscatter (reflected) energy with the data the tag contains. The interrogator listens for the frequency shifts in the reflected energy and converts these shifts into an information bit sequence. Current design for RF tags operate in the ISM (Industry, Science and Medicine) band at 2.45 GHz. The design is easily adaptable to other bands in the microwave and millimeter wave frequency range, Figure 7.

Each digital sensor is connected to an RF tag via a digital data interface to download the tag's ID and information to the RF interrogators. Analog sensors require an A/D converter to provide the digital data stream making up the tag's ID and information. The A/D interfaces are accomplished between the sensor and the RF tag. The tags will provide two-way digital communication capability, a relatively significant bandwidth uplink for transferring the data from the sensors and a limited bandwidth downlink to enable the control of sensors and local sensor processing. The RFID tag has been demonstrated at data rates of 50 Kbit/sec at up to 15 m. Since the RF tag has no active transmitter, its production costs and power requirements are very low. These wireless sensors have been installed on the ex-USS *Shadwell* on portions of the main and 2nd deck, forward of frame 29, to demonstrate the ability of the system to detect and monitor ship conditions, crew location and personnel physiological state of status monitor equipped crew members. RF tags are assigned to all sensors used to monitor ship and personnel condition on the main and 2nd deck in *Shadwell's* MicroLan test area.

Wireless MicroLAN Network

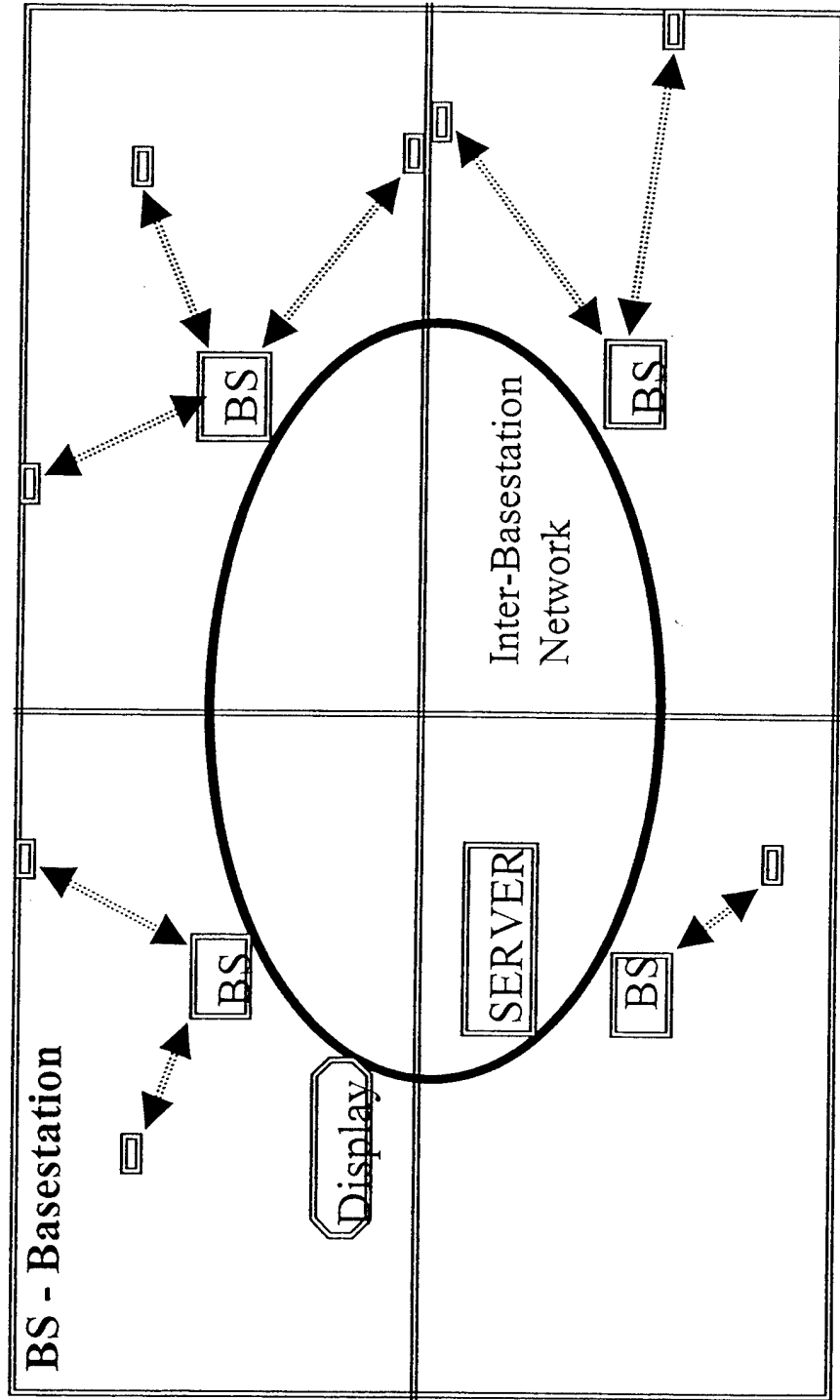

Figure 6. RF Tag System Overview

Wireless MicroLAN - Typical System Solution

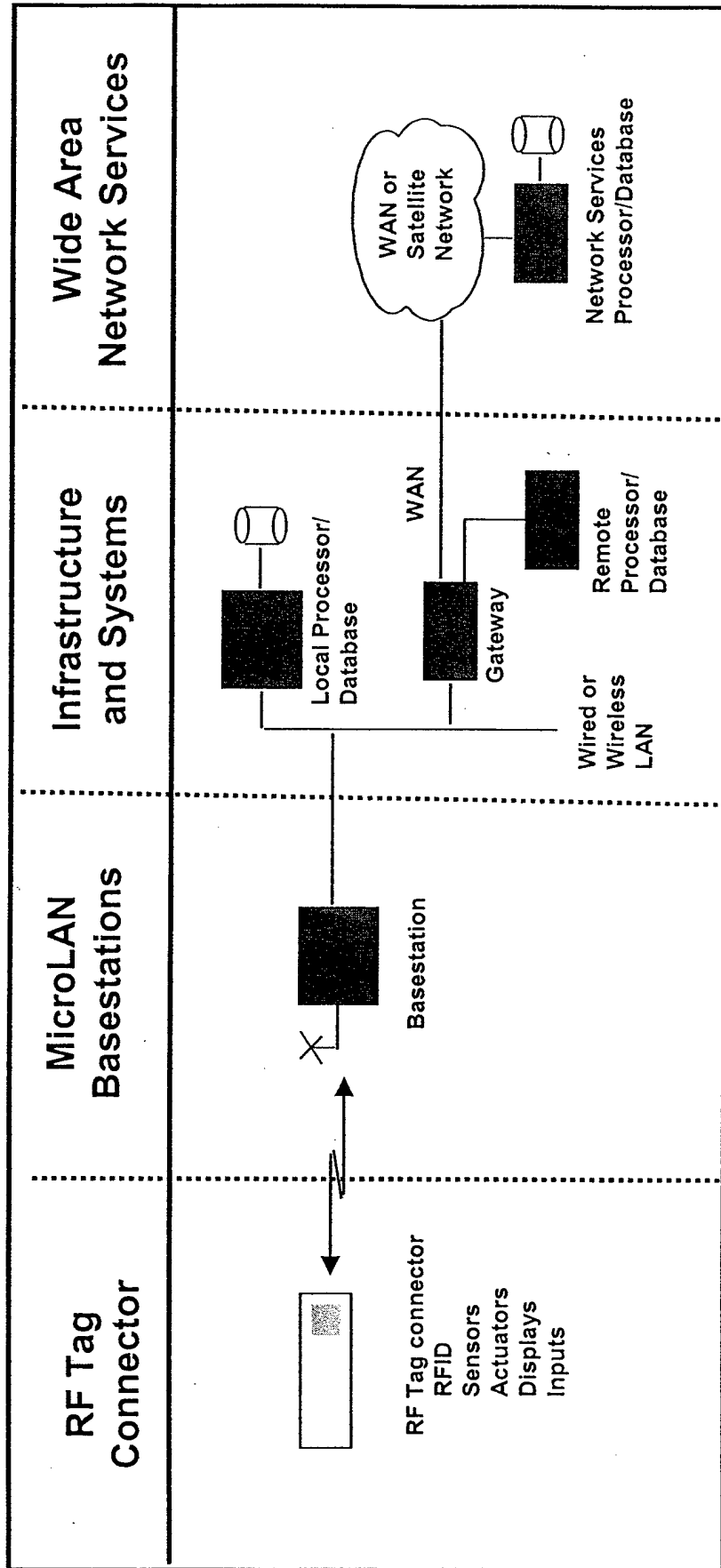

Figure 7. System Solution

3.2 Personnel Status Monitors (PSM)

A major effort was undertaken to develop personnel badges based on RF tags.[5] This would allow the tracking of ships personnel by the RF tag communications system. Although much smaller and thinner badges could have been developed, this effort focused on the use of the technology and not the packaging issues. The RF tags offer a read/write capability which allows for updating of pertinent information (long term and recent medical history) on the tag. DARPA sponsored a program to develop a Personnel Status Monitor (PSM), which monitors the location and physiological state of a sailor through the monitoring of body conditions such as temperature, blood pressure, pulse rate, body position and shivering, Figure 8. The PSM was developed by Sarcos, Inc., by interfacing MEMS sensors with Lucent RF tag transceivers. The personnel badge was interfaced with the PSM to provide not only location, but also information on the wearers physiological state through the aforementioned monitoring of body conditions. Demonstrations confirmed the ability of the PSM to identify and track personnel entering or leaving an area and identifying if specific personnel were in an area, but because of extensive multipath and signal leakage between compartments greater location precision within a given compartment were not reliable. Further work is necessary to improve the location precision to better than a given compartment, but the demonstrated location and PSM capabilities were impressive and deserve further investigation.

3.3 Wireless Environmental Sensors

The use of the RF tags for wireless sensor data communication of COTS sensors[6] is a natural follow-on to the PSM discussed before and because of Lucent Technologies prior wireless sensor development under DARPA's Ship Systems Automation Program, Figure 9. The RF tag program identified smoke and temperature sensors for this system demonstration because of the ease of incorporation with wireless RF tags and their ability to be graphically represented in the demonstration showing the migration of heat and smoke through the instrumented area that the RF tag system was designated to cover. This also demonstrated the ability to interface a variety of sensors that would be necessary to cover an operational ship. The specification of which sensors to use and the locations to be sensed were specified in the program definition, as were the frequency of data collection and the nature of the data control (as enabled by the bi-directional wireless communication). Technology now exists to modify COTS sensors, integrating an analog to digital interface (if necessary) and the RF tags to provide a truly wireless sensor. The wireless sensors provided for this demonstration system are battery powered and will operate for a finite time ~<90 days, before batteries must be replaced. If wireless sensors are used in shipboard systems, in the future, the battery life must be extended from months to years of operation by limiting power requirements, use of voltage scavenging techniques and other

Personnel Status Monitor Information

<u>F</u> ire Fighter ID	PSM TAG ID 57, Cmdr Farley - #5		
<u>S</u> tatus	Partial Data	<u>B</u> ody Position	<u>S</u> hivering
<u>H</u> eart Rate	105	<input checked="" type="radio"/> Up <input type="radio"/> Down	<input type="radio"/> Yes <input checked="" type="radio"/> No
<u>S</u> kin Temperature	36.2	<u>M</u> otion	Time of this Data at the Server:
<u>E</u> nv Temperature	No Data	<input checked="" type="radio"/> Yes <input type="radio"/> No	Thu Nov 12 16:07:33 1998
<u>R</u> eport By	LTwM003		
<u>L</u> ocation	Second_Deck_A_F22_F29_6		STOW
		<input type="button" value="OK"/>	

Figure 8. Personnel Status Monitor Display

Paradigm Shift

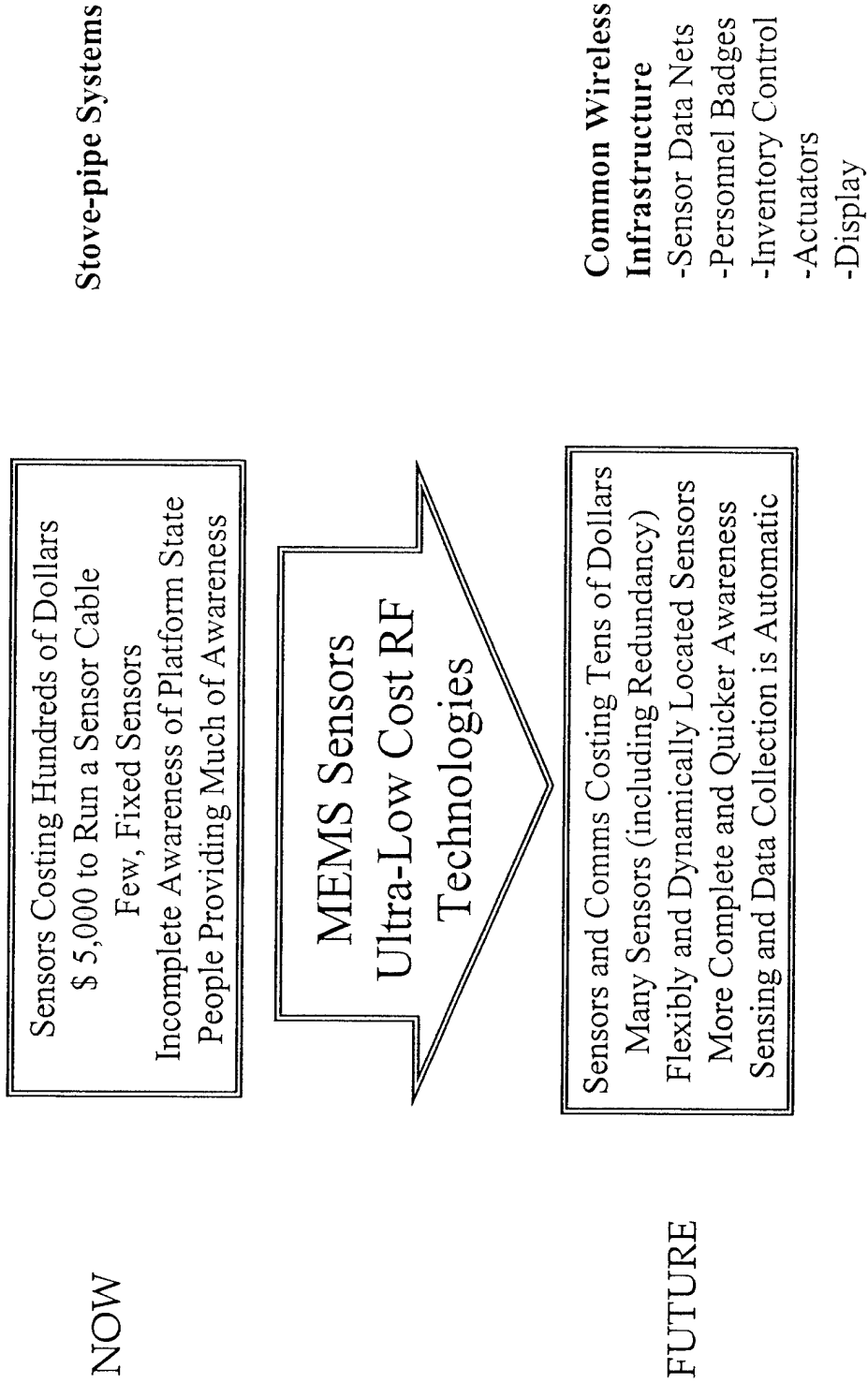

Figure 9. Sensor Automation

power reduction techniques. Figures 10 and 11 show the system configuration and location of MicroLan components demonstrated on ex-USS *Shadwell*, covering parts of the main and second decks, forward of frame 29. Instructions guiding the power up and power down of the MicroLan system can be found in Appendix "A".

3.4 The Wireless Interrogator

The RF MicroLan system[7] uses a backbone of ten (10) RF Interrogators to cover the MicroLan test area on the main and second deck on the ex-USS *Shadwell*. Each of the interrogators has a number of wireless sensors within its RF range that it interrogates for sensor data. The Interrogators are used to provide wireless communications for; (a) Interrogator to Tag (downlink), (b) Tag to Interrogator (uplink) and (c) a wireless 2.45 GHz WaveLan local area network (LAN) operates in unlicensed spectrum (2400 - 2483.5 MHz) and uses frequency hopping spread spectrum technology and an ethernet cable (10/100) to provide an ethernet connection between Interrogators, servers and WaveLan system on *Shadwell*. The Interrogator to Tag wireless connection is an amplitude modulated (AM) signal. The Tag synchronizes with the AM signal and then can receive messages from the Interrogator. The Tag to Interrogator wireless connection uses Modulated Backscatter (MBS) signals. The Interrogator transmits a continuous wave (CW) signal to the Tag. The Tag recognizes this CW signal and by changing its antenna impedance, reflects and modulates the CW signal, thus transmitting data back to the Interrogator. The Tag is not an active transmitter.

Ships' power with rechargeable battery back-up, power the interrogators under normal conditions. The internal rechargeable batteries within the interrogators power the units for 8 to 10 hours if ships' power is lost. These batteries will not be recharged automatically when power returns, if they have become discharged, due to loss of ships' power. The battery chargers must be manually attached to the batteries (Interrogator and internal computer) after opening the interrogators.

3.5 Information Collection and Delivery (IC&D)

The IC&D subsystem[8] consists of the WIM Network computer, the WIM Collection Server, the WIM databases and the WIM Delivery Server. The IC&D subsystem collects data from all interrogators. The interrogator data is identified, recorded, combined with the previous data and presented to the GUI subsystem, Figure 12. The WIM network computer is located in the RF Tag Interrogator enclosure and attached to the interrogator by its serial interface. Its function is to accept the data stream from its co-located interrogator and to make a network connection to the WIM collection server and transmit data packets. The WIM network computer consists of; (1) a Toshiba Libretto 110 CT mini notebook computer used as an embedded

- Interrogator
- RF LAN Wavepoints
- Antenna
- Temperature
- Smoke

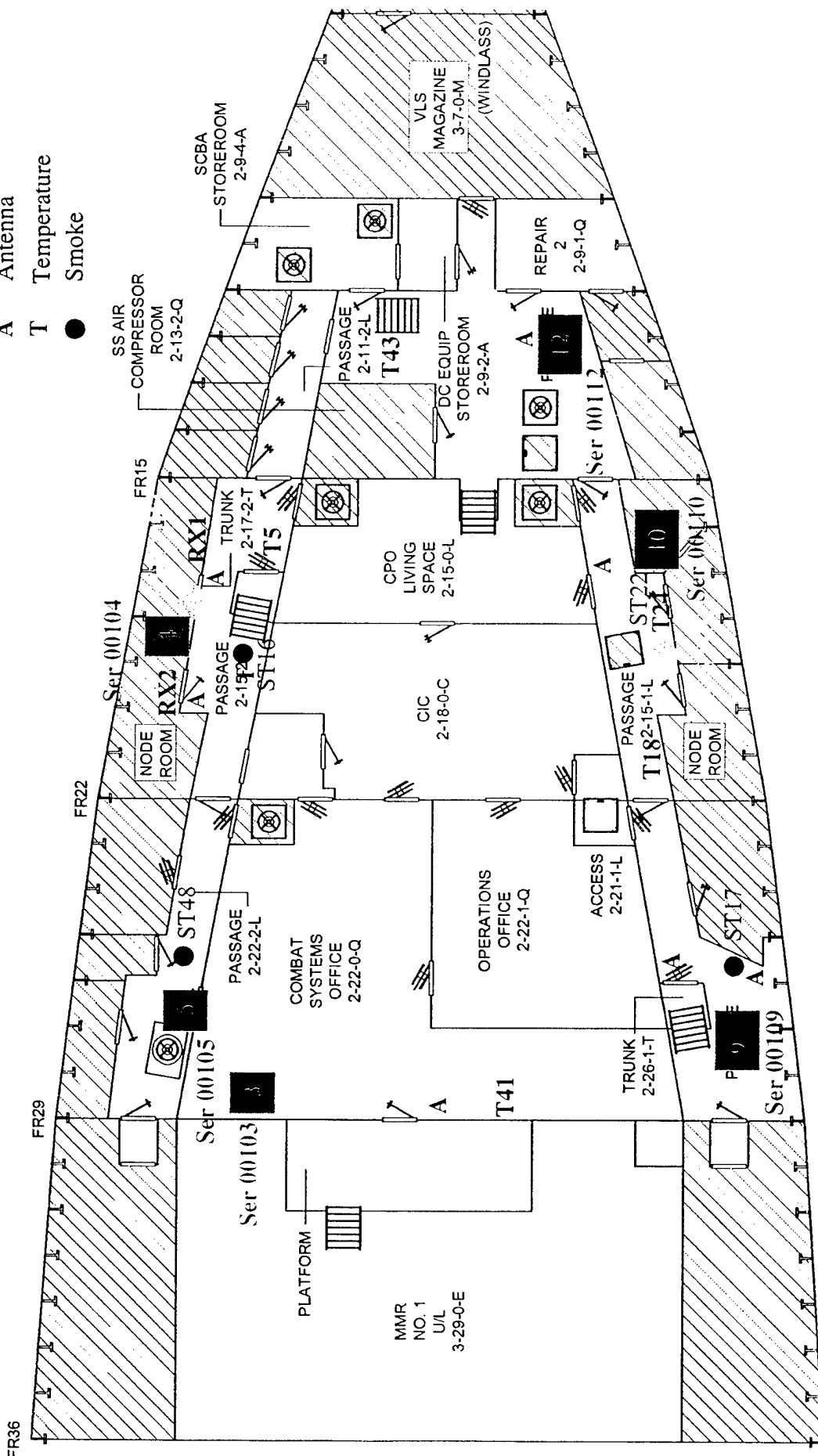

Figure 10. RF Tag System Configuration, Second Deck

- Interrogator
- RF LAN Wavepoints
- A Antenna
- T Temperature
- Smoke

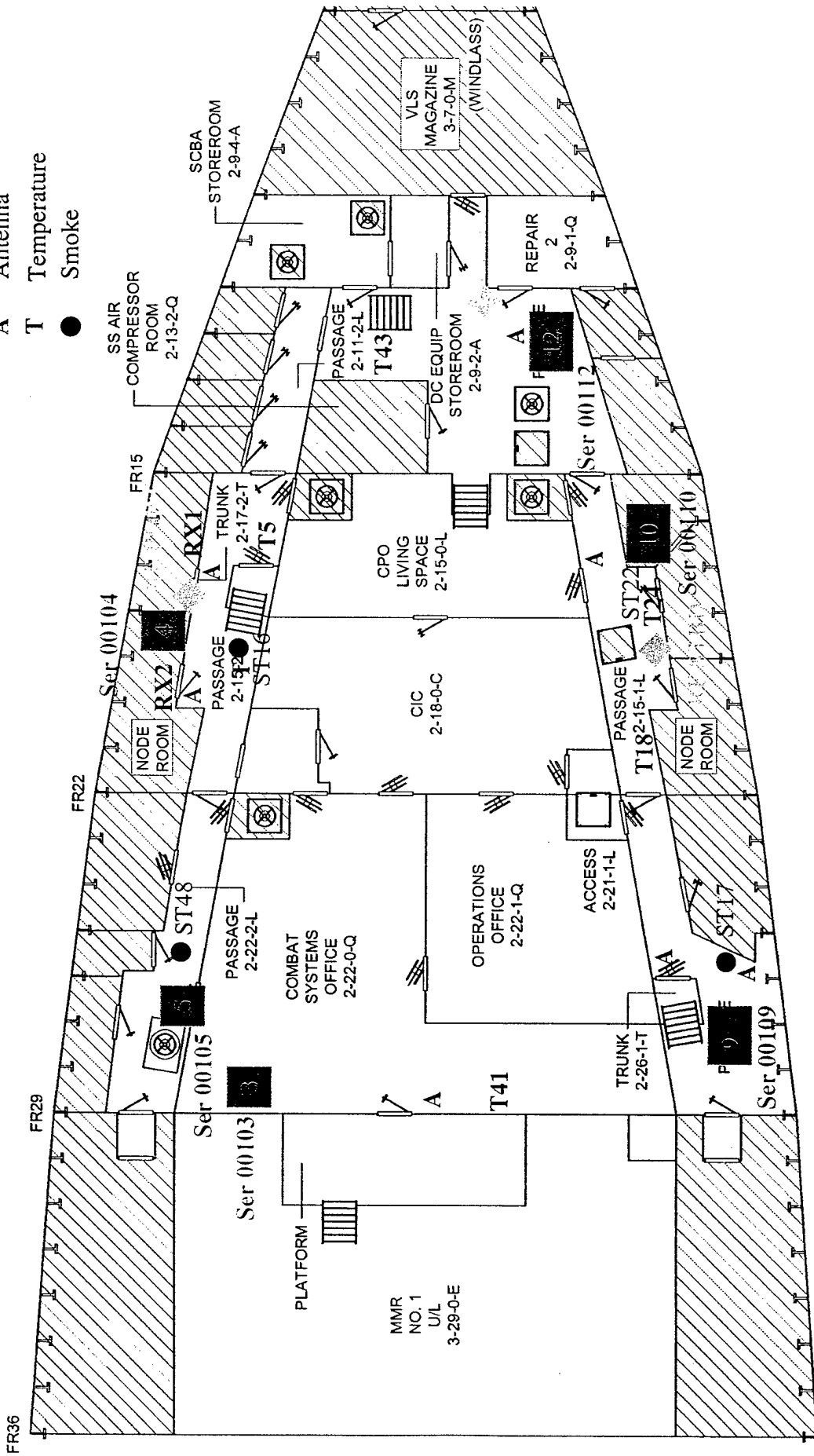

Figure 11. RF Tag System Configuration, Main Deck

Internet Oriented Database

File Edit View Go Bookmarks Options Directory Window Help

Back Forward Home Edit Reload Print Open Find

Location: <http://wim.data.lucent.com/cgi-bin/queryint?exec=querywim&newsrch=wimquery.html&netcid=&tagtype=&tagnum=&tagid=×tamp=&>

LTWM001 03	00014	906047788	18,013:009=01
LTWM001 04	00035	906047788	00,236:234=10
LTWM001 02	00046	906047790	3278115a,132:130=01
LTWM001 04	00008	906047791	00,104:102=00
LTWM001 03	00035	906047797	36,237:235=09
LTWM001 03	00008	906047798	1d,105:101=00
LTWM001 03	00014	906047800	18,015:013=00
LTWM001 02	00046	906047800	3278115a,134:132=02
LTWM001 04	00035	906047806	00,238:236=08
LTWM001 04	00014	906047806	00,016:010=03
LTWM001 02	00046	906047809	3278115a,136:134=00
LTWM001 03	00008	906047810	1d,107:105=02
LTWM001 03	00014	906047815	18,017:015=01
LTWM001 03	00035	906047816	36,239:237=09
LTWM002 04	00008	906047817	00,108:106=06
LTWM001 04	00008	906047817	00,108:104=00
LTWM001 02	00046	906047818	3278115a,138:136=00
LTWM002 03	00008	906047824	1d,109:107=08
LTWM001 04	00035	906047825	00,240:238=07
LTWM001 03	00008	906047826	1d,109:107=03
LTWM001 03	00014	906047827	18,019:017=03
LTWM001 02	00046	906047828	3278115a,140:138=01
LTWM002 04	00008	906047831	00,110:108=09
LTWM001 04	00008	906047831	00,110:108=00
LTWM001 03	00035	906047834	36,241:239=06
LTWM001 04	00014	906047836	00,020:016=04

Document Done

Figure 12. Database Configuration

computer, (2) Windows 95 operating system with TCP/IP stack, (3) WIM network computer client software, (4) WaveLan PCMCIA Ethernet Adapter and (5) shared access on a WaveLan Bridge. The WIM Collection Server shares use of a UNIX hardware platform and operating system, uses UNIX Semaphore operations system calls and wireless MicroLan collection server application code. The WIM Collection Server accepts and maintains connections from all WIM network computers and reads, parses (analyzes data based on expected or wanted parameters), separates and records all RF Tag and network computer identification data in the WIM RF Tag database, Figure 13. The WIM databases are the WIM Tag information database, the WIM configuration database, the WIM Tag Types database and the WIM Tag assignments database. The databases are designed for fast access for up to 100 simultaneous network computers and up to 100,000 RF Tag sensors. The databases contain all of the data and configuration information for the entire wireless MicroLan installation. The WIM delivery server consists of the shared use of a UNIX hardware platform and operating system, UNIX Semaphore operations system calls, COTS HTTP server and common gateway interface (CGI) and the WIM database Query CGI code. The WIM delivery server uses standard information delivery technology including access restriction from a single individual to unlimited worldwide access.

The RF Tag interrogator sweeps the area and collects data from all RF Tags that respond, Figure 14. All collected data is sent upstream to the network computer. On the first data stream the network computer "nails-up" a connection to the WIM server via WaveLan. The network computer identifies the interrogator/network computer pair to the server. It maintains the connection and sends the data packet. Subsequent data packets check the integrity of the connection and immediately transmit packets of data. The WIM collection server "camps on the network", listening for any network computers that request a connection. The WIM collection server constantly checks the integrity of the connections to all network computers and breaks the connection whenever an error is detected. The breaking of the connection from either client or server automatically causes a new connection to be established on a subsequent data stream. The WIM collection server is designed to accept simultaneous connections for up to 100 network computers as well as interrogation from a web browser for diagnostics. Each server connection to a network computer runs in a separate process on the UNIX platform's OS, enabling the full resources of the platform to be used. Each server connection receives data packets from the associated network computer, parses and stamps the data and stores the data in the WIM database with the aid of the Semaphore operations. Multiple records may be received within single data packets, and the server will separate and store the individual records with one Semaphore operation, for efficiency. The entire thread, up to this point, is constantly repeated at a high speed, and the amount of data is dependent on the number of RF Tags configured. The delivery of the data to the client GUI application is performed on an "as requested " basis and is

Netscape - [Wireless Microlan Database Query]

File Edit View Go Bookmarks Options Directory Window Help

Back Forward Home Edit Reload Open Print Find

Location: <http://wim.data.lucent.com/cgi-bin/query.pl?exec=querywimtags&newsrch=wimtags.html&tagtype=%&tagid=%&assigned=%&recno=%>

Tag Type	Type	Serial No.	Identification of Person or Equipment to which Tag is Assigned
00	00000	0 0 0	Simulated Type and Tag (for Network Connect Time and Testing)
02	00046	1 74 15	Personnel Status Monitor Simulator - PG1
02	00055	1 71 15	Personnel Status Monitor Simulator - PG2
02	00062	1 68 15	Sarcos Personnel Status Monitor #1
02	00002	1 65 15	Personnel Status Monitor Simulator - HN
02	00051	1 62 15	Sarcos Personnel Status Monitor #2
02	00053	1 59 15	Sarcos Personnel Status Monitor #3
02	00054	1 56 15	Sarcos Personnel Status Monitor #4
02	00057	1 53 15	Sarcos Personnel Status Monitor #5
03	00043	2 74 46	Temperature Sensor Second_Deck_A_F11_F15_1
03	00022	2 57 65	Temperature Sensor Second_Deck_S_F15_F22_2
04	00022	2 54 68	Smoke Detector Second_Deck_S_F15_F22_2
03	00018	2 39 68	Temperature Sensor Second_Deck_S_F15_F22_2
03	00024	2 50 69	Temperature Sensor Second_Deck_S_F15_F22_2
03	00005	2 59 31	Temperature Sensor Second_Deck_P_F15_F22_3

Netscape

Figure 13. RF Tag Database

Netscape - Wireless Microlan Database Query

File Edit View Go Bookmarks Options Directory Window Help

Back Forward Home Edit Reload Images Open Print Find Stop

Location: <http://wim.server.lucent.com/cgi-bin/queryint?exec=querywimcl&newstch=wimconf.html&netcid=%located=%&recno=%&psstyle=1&qstyle=1&st>

Network Computer ID	Compartment / Location
LTWM000	Main_Deck_Compart_51
LTWM001	Upper1_Deck_Compart_61
LTWM002	Upper2_Deck_Compart_71
LTWM003	Upper3_Deck_Compart_81
LTWM004	Below1_Deck_Compart_41
LTWM005	Below2_Deck_Compart_31
LTWM006	Below3_Deck_Compart_21
LTWM007	Below4_Deck_Compart_11
LTWM008	Below5_Deck_Compart_06
LTWM009	Below5_Deck_Compart_01
LTWM999	Simulated LTWMNETC

[[New Search](#)]

Document Done

Figure 14. Data Collected During Interrogator Sweep

completely independent of the collection process. In addition to RF Tag data, the GUI application must obtain configuration information from the WIM databases to facilitate the interpretation of the data. "As required," the GUI will request and accept configuration data for the placement of network computers, and the translations of RF Tags and Tag types to people and things. Also, "as required," but on a more frequent basis, the GUI application will request RF Tag data by any combination of parameters to accomplish the requested presentation. Since the GUI runs on a Windows 95 platform, and the WIM databases are hosted on a HTTP server running HTACCESS, access to the information can be controlled by the operator.

3.6 Graphic User Interface (GUI)

The GUI subsystem[9] displays WIM data in a user friendly environment, Figure 15. The information that is gathered through the use of the RF tags needs to be collected and displayed. The display has an underlay which shows the ship spaces and compartments being protected. An overlay will position the data on the underlay. The underlay was developed using drawings of the ex-USS *Shadwell* for the portion of the ship where the system is installed. Overlaid on the underlay is the data collected using the RF tags during the test or demonstration and updated over time. The overlays include data from environmental sensors displayed at the sensor locations and the identity of the firefighter or crew member at their approximate location. Additional displays, including a vital signs display for the PSM equipped crew members, can be brought up from the main display, Figure 16. The display development was minimal, due to the limited resources available, but was enough to convey the collected information, adequately, Figures 17, 18 & 19. Data was collected during the demonstrations and stored in the servers and is now available to review or rerun the demonstrations for training and analysis purposes.

4.0 REDUCED SHIP'S CREW BY VIRTUAL PRESENCE (RSVP) ADVANCED TECHNOLOGY DEMONSTRATION (ATD)

The goals of the Office of Naval Research's RSVP program[10] was to demonstrate high-risk technologies for a fault-tolerant, intra-compartment, wireless MEMS based sensor network which enables real-time, internal, ship-wide situational awareness. RSVP will monitor the ship in four (4) functional areas; (1) environmental, (2) structure, (3) machinery and (4) personnel status, Figure 20. Data from these functional areas will be archived and an operator will be provided with the health status of RSVP's own operational components. The environmental function will provide an operator with the environmental status (temperature and humidity) of each space, alert an operator to an emergency environmental condition such as fire or flooding and provide the operator with the recent environmental history of the space. [The structural function will provide the status of the hull girder stress, hull acceleration and corrosively of the ship's primary structure and alert an operator to an emergency structural condition that has developed and provide a recent history of the ship and its contents. The machinery function will provide the operational

Real-Time Shadwell Display

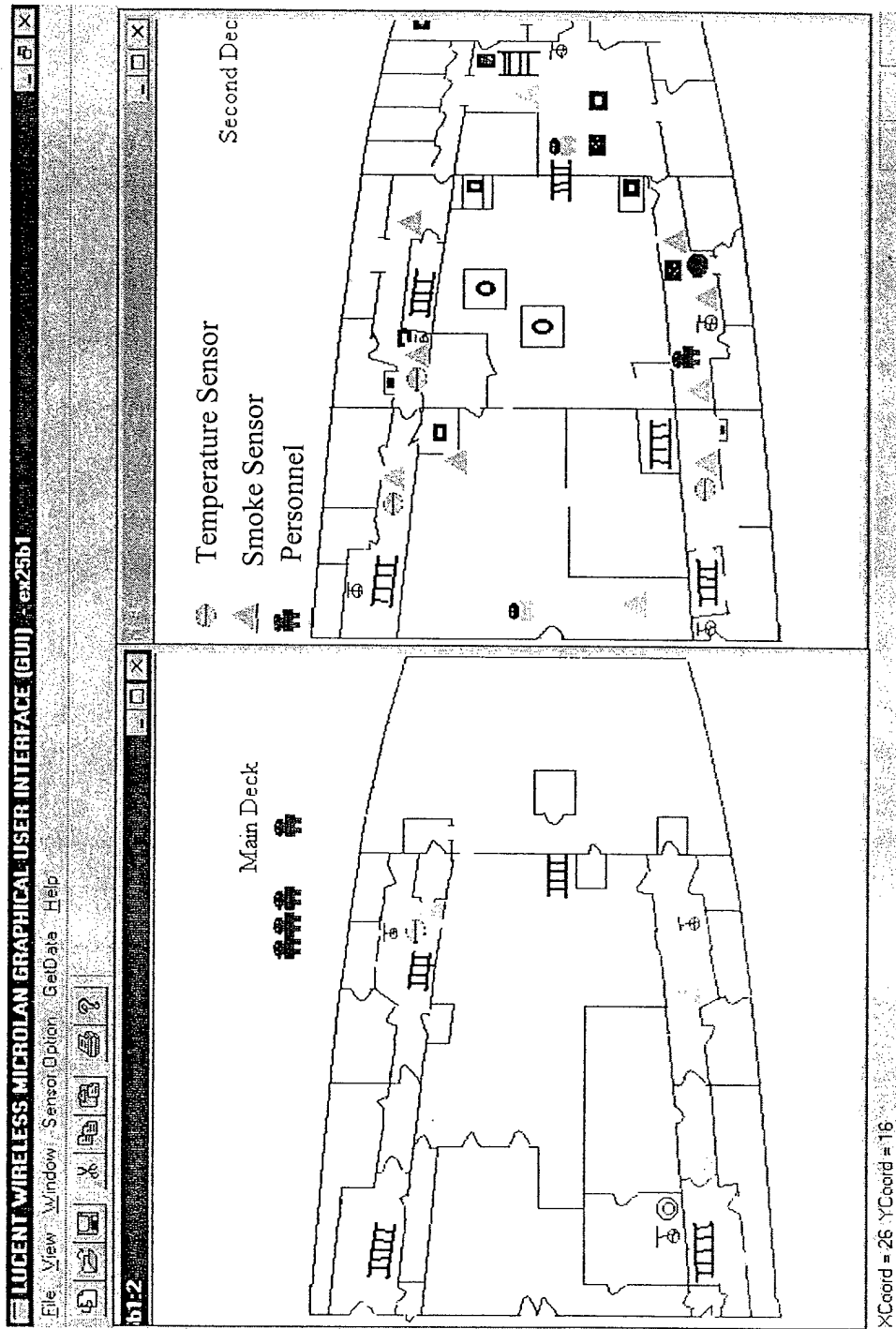

Figure 15. GUI Display Of MicroLan Data

Personnel Status Monitor Information

<u>F</u> ire Fighter ID	PSM TAG ID 62, Scene Leader - Plackett - #1	
<u>S</u> tatus	Warning!	<u>S</u> hivering <input type="radio"/> Yes <input type="radio"/> No
<u>H</u> eart Rate	123	<u>B</u> ody Position <input type="radio"/> Up <input checked="" type="radio"/> Down
<u>S</u> kin Temperature	36.0	<u>M</u> otion <input type="radio"/> Yes <input type="radio"/> No
<u>E</u> nv Temperature	No Data	Time of this Data at the Server: Thu Nov 12 16:11:31 1998
<u>R</u> eport By	LTW/M009	<input type="button" value="STOW"/>
<u>L</u> ocation	Second_Deck_5_F22_F29_5	<input type="button" value="OK"/>

Figure 16. Personnel Status Monitor, Vital Signs Display

Temperature Sensor Information

<u>I</u> ag ID	17
<u>T</u> emperature	35
<u>L</u> ocation	Second_Deck_S_F22_F29_5
<u>R</u> eported By	LTW/M009

Time of this Data at the Server: Thu Nov 12 16:11:39 1998



Figure 17. GUI Display Development

Smoke Sensor Information

Iag ID: 16
Status: SMOKE ALARM!
Location: Second_Deck_P_F15_F22_3
Reported By: LTW/M004

Time of this Data at the Server: Thu Nov 12 16:10:22 1998

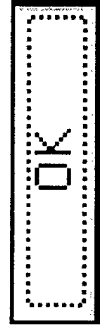

Figure 18. GUI Display Development

Netscape - [Wireless Microlan Database Query]
 File Edit View Go Bookmarks Options Directory Window Help
 Back Forward Home Edit Reload Images Open Print Find Stop

Location: <http://wim.data.lucent.com/cgi-bin/queryint?exec=querwimrules&newsrch=wimrules.html&tagtype=%&rule=%&condition=%&color=%&reco=%&p>

Tag Type	Rule	Condition	Color
02	Init State	No Data	White/White
02	RAWHR<221	Part Data	White/Green
02	RAWST<251	Part Data	White/Green
02	MO<3	Part Data	White/Green
02	SH<3	Part Data	White/Green
02	BP<3	Part Data	White/Green
02	RAWET<211	Part Data	White/Green
02	RAWHR<221&RAWST<251&MO<3&SH<3&BP<3&RAWET<211	Normal	Green/Green
02	HR<60	Warning	*/Amber
02	HR>170	Warning	*/Amber
02	ST<32	Warning	*/Amber
02	ST>40	Warning	*/Amber
02	SH=1	Warning	*/Amber
02	BP=0	Warning	*/Amber
02	ET<-6	Warning	*/Amber

Document Done

Figure 19. GUI Display Development



Concept

RSVP

**MEMS Based Sensor Clusters
Operating on Scavenged Energy**

**Environmental / Structural
Monitoring**

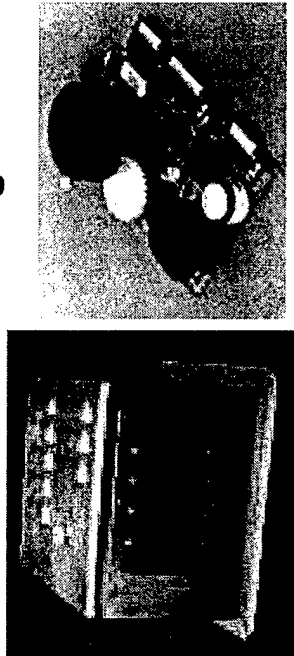

**Data Fusion/Archive
Architecture**

**Radio &
Camera**

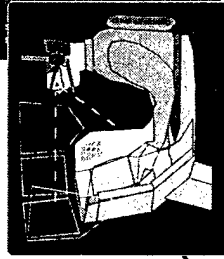
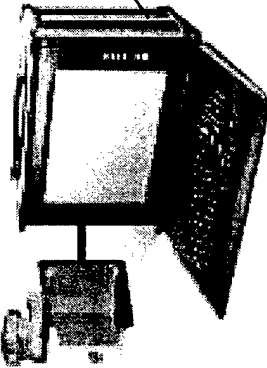

Situational Awareness

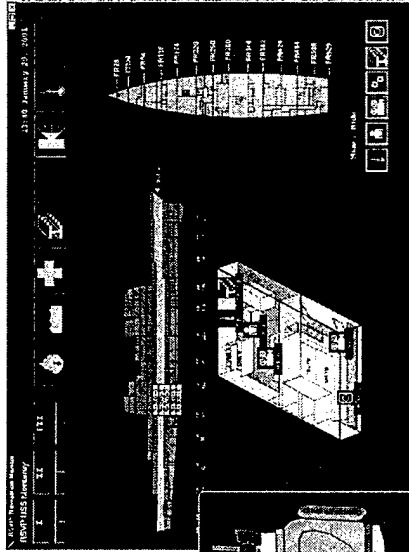

**Machinery Health
Monitoring**

**802.11 Wireless
Interface**

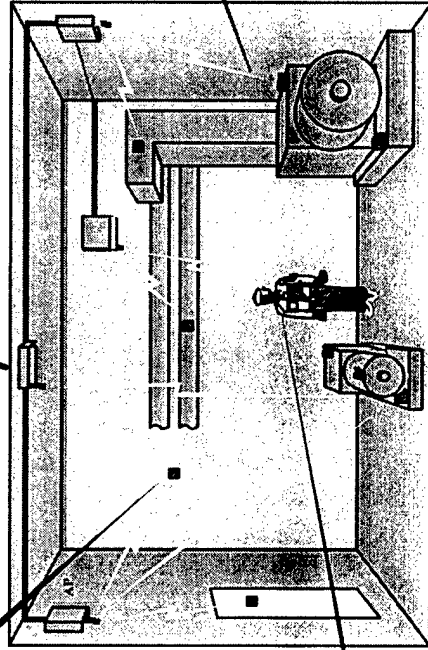

Personnel Monitoring



**System Health
Monitor**



**Intelligent
Bearing
Health
Monitor**



**Intelligent
Generator
Health
Monitor**



**Intelligent
Component
Health
Monitor**



Intra-compartment Wireless Networks

Figure 20. RSVP Concept

status, the configuration and the health status of the ship's machinery.]* The personnel function will provide an operator with the physiological status (pulse, skin temperature and shivering) and location (identification of ship space) of crew members. The system is required to remain operational during all operational and damage conditions. [Sensor clusters used to determine operational parameters are designed to operate for extended periods of time (goal is 5 years after installation). This will require some form of power scavenging to charge the batteries.]* The sensors provide data based on time, event or query. Video cameras are located on each access point providing multiple views of compartments to an operator monitoring the system.

Video and communications from the scene (compartment) is accomplished using multiple wireless access points (AP's) located in each compartment, Figure 21. Each AP performs data logging and maintains a video loop recorder. The access points form an IEEE 802.11 compatible ethernet communications backbone within the compartment to wirelessly communicate machinery health using intelligent component health monitors (ICHM) for bearings, generators and components, Figure 22, personnel status monitors (PSMs) for personnel health status and location and environmental and structural ship components using MEMS based sensor clusters for sensed parameters within the compartments, Figure 23. Data fusion technology is used to archive and disseminate compartment information to the integrated condition assessment system (ICAS) and internal ship situational awareness displays. In addition to managing the communication necessities of RSVP, each AP's incorporates a video camera to enhance virtual presence. Infra red (IR) sensors can also be used to monitor particularly sensitive spaces, although not currently installed on *Shadwell*. Each of the multiple AP's in each compartment will perform data logging and will maintain a video loop recorder. Real-time or recorded video can be transmitted over the communications backbone from any AP in any space. AP's within each space exchange sensed data with each other so each can make decisions based on all of the data in the space. One AP in a compartment, is designated to communicate with the watchstander's console or other system, at a time.

4.1 Intelligent Component Health Monitors (ICHM)

Machinery health monitoring is accomplished using a device that can monitor and access the health of a machinery component. The Intelligent Component Health Monitor (ICHM) must sense and measure physical parameters, make some decision regarding the condition of the component based on the measurement and communicate the results of that measurement and decision to the System Health Monitor (SHM). The functions of the ICHM include: (1) parameter sensing (temperature, pressure, vibration and acoustic emissions), (2) Signal conditioning (sensor power, filtering and amplification), (3) data conversion (multiplexing and A/D conversion), (4) calibration (generate test and calibration signals and normalize data), (5) acquisition control (synchronizing, timing and sequencing), (6) data analysis and alerts, (7)

*Not demonstrated on ex-USS *Shadwell*.

FY 2001 Demo on Shadwell

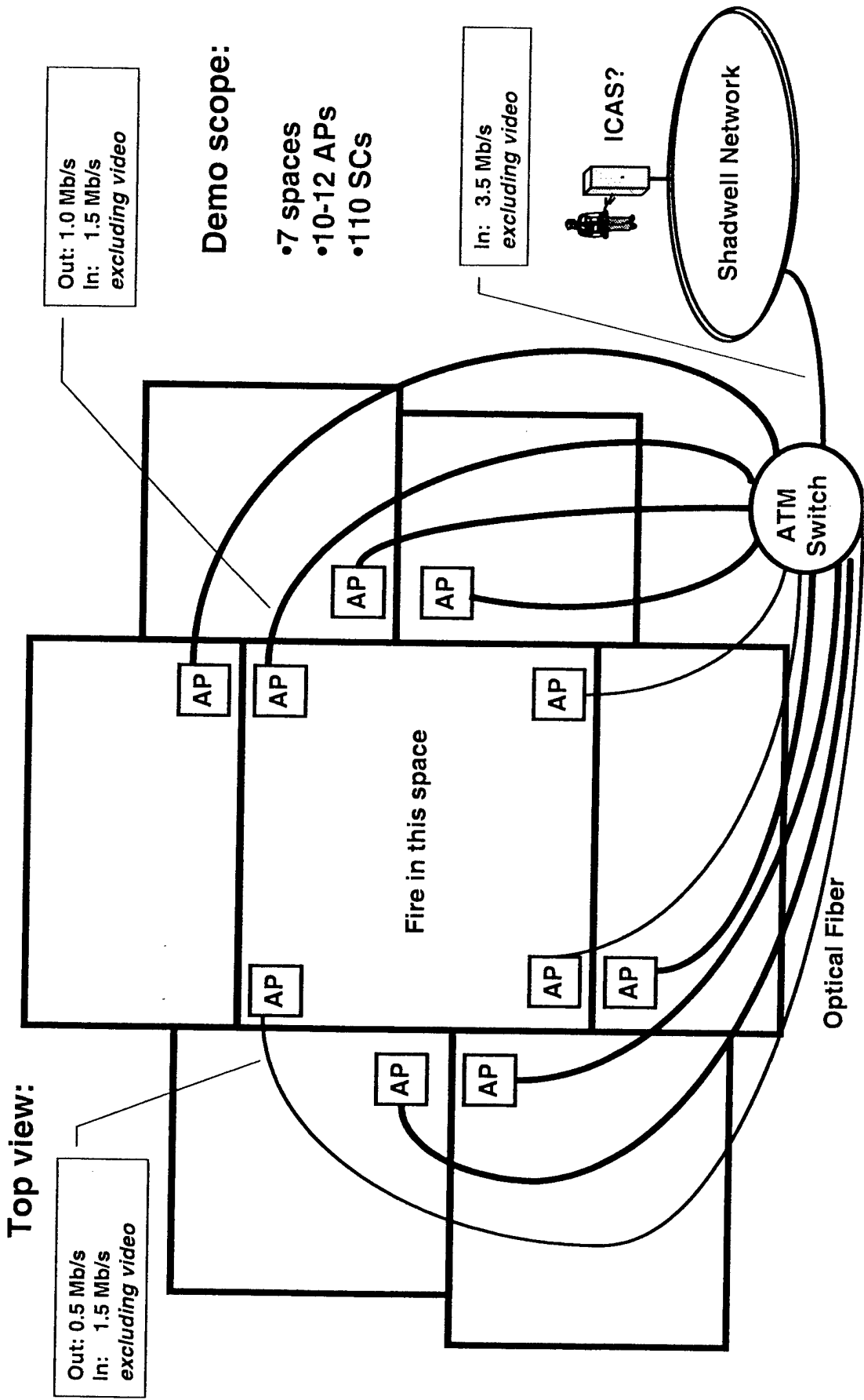

Figure 21. Layout Of Access Points In Compartments



Health Monitoring System

RSVP

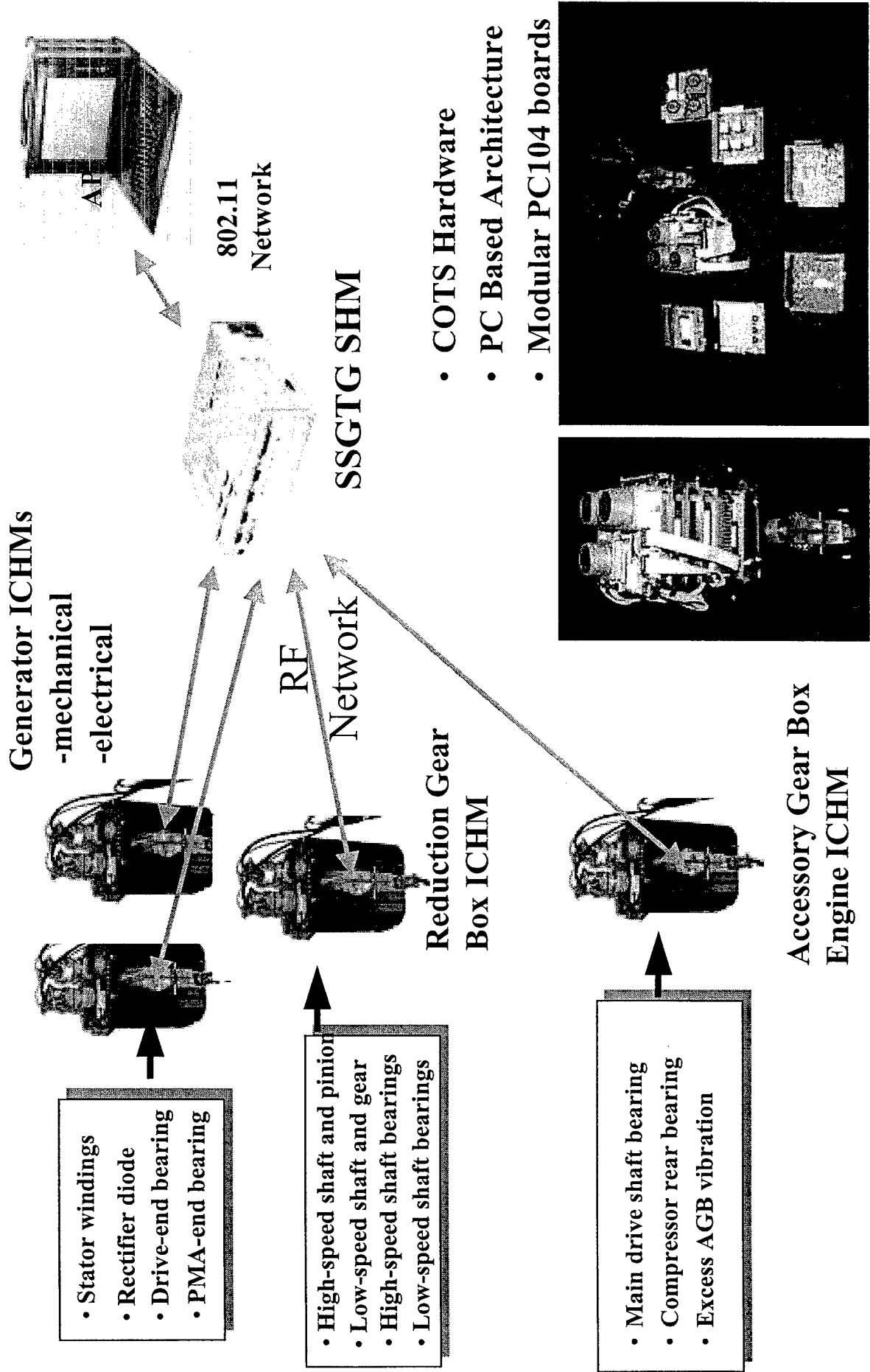
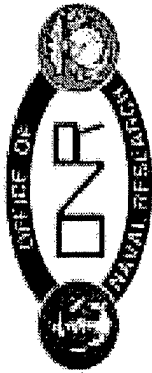
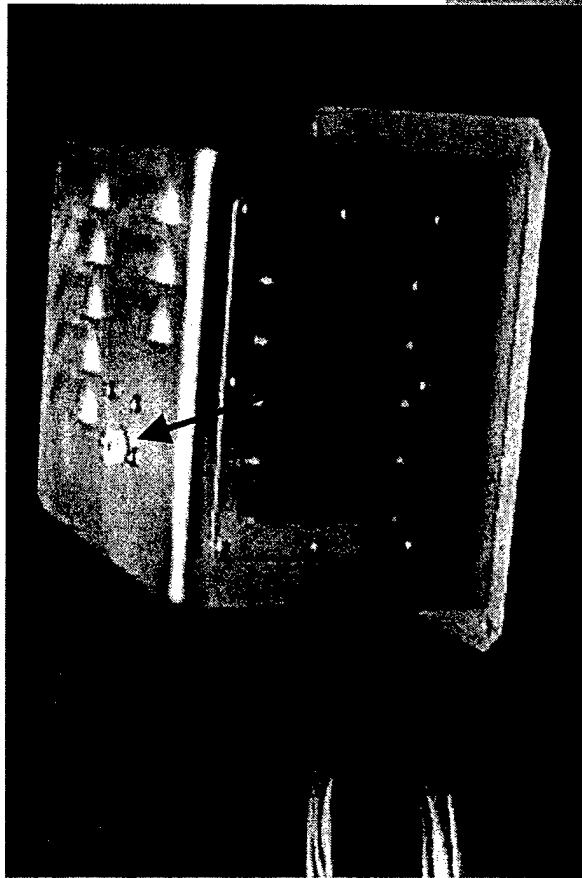

Figure 22. Machinery Health Monitoring



Environmental Sensor Cluster *RSVP*



Environmental Sensed Parameter

- Temperature
- Humidity
- Pressure
- Noise (sound)
- Flooding
- Smoke
- Ionization
- Oxygen
- Carbon Monoxide
- Hatch Position

Radio Module Alt. PMM Module Sensor Module

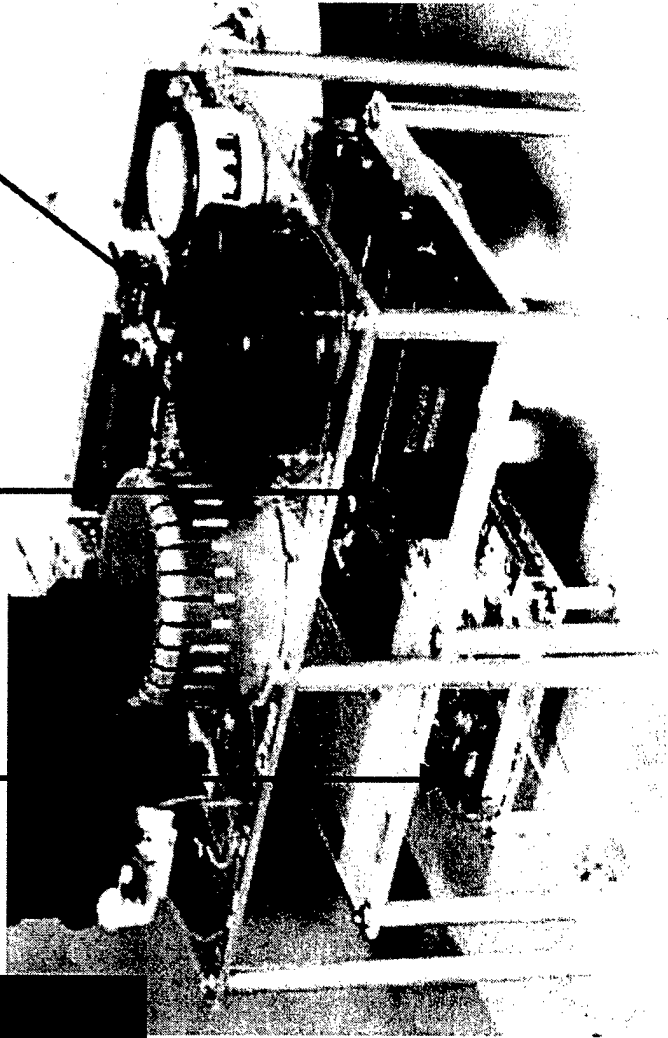

Structural Sensed Parameter

- Strain
- Shock
 - Low g (0-2g)
 - High g (0-100g)
- Temperature

Figure 23. Environmental Sensor Clusters

communication (receive control, message synchronization, communicate data and alerts to and from SHM) and (8) system support (comm control, data acquisition and analysis, system clock, software loading and support and memory management, power supply, self test and interfaces). The ICHM monitors the mechanical and electrical health of major ship machinery components. The ICHM is comprised of Commercial-Off-the-shelf (COTS) hardware like a personal computer used to monitor the modular PC boards that provide information on stator windings, rectifier diodes, drive end bearings, PMA-end bearings for ICHMs generators #1 and #2, main drive shaft bearings, compressor rear bearings and excessive vibration in the accessory gear box, suction/discharge pressure, suction/discharge temperature and suction/discharge acceleration for the ICHM fire pump #2.

4.2 Environmental Sensor Clusters

The sensor cluster is a self-contained unit that senses its environment or structure situation, autonomously determines some level of casualty situation, and reports the information to an AP. The clusters are distributed throughout a compartment based on the compartment characteristics, such as obstructing equipment, environmental conditions, habitability, and other factors. Overall system goals of complete compartment coverage, low maintenance and survivability are achieved through sensor cluster redundancy throughout the compartment. Due to the need for low maintenance, translated to long operational time, the power sources should be scavenged and battery power. This will ease installation concerns and cost by negating the need to tie into ship's power. Ultra low power utilization is achieved using sleep mode, switching power to sensors, concise firmware algorithms and low periodic transmission rates. EEPROM memory is used to store non-volatile information that needs to be updated at a very slow rate, such as calibration information, sensor cluster ID, sensor cluster location, as an example. Storing this information in random access memory (RAM) would require more frequent updates from the AP's and a more complex data base.

The environmental sensors cluster consists of sensors to monitor temperature, humidity, pressure, noise, flooding, smoke, oxygen and carbon monoxide which have been packaged along with a radio module, a power management module (PMM) and an antenna. The sensor modules can be configured to use different combinations of the aforementioned sensors to fit the environmental sensing requirements of any ship compartment. The sensor clusters used for the *Shadwell* demonstration were not designed to scavenge for power, but were designed to have internal communications capabilities and use MEMS sensors. They were designed to accept external RF communications, use external battery power and use conventional sensors so that the failure of any of these design initiatives would not have slowed overall program development. The Sensor Cluster functionality is such that it accommodates both environmental and structural configurations. The clusters are able to sense parameters necessary to detect problems, and relay information to the AP's for dissemination and storage.

4.3 Personal Status Monitors

The personal status monitors consists of an integrated sensor unit (ISU), a communications interface unit (CIU) and an access point (AP). The ISU measures heart rate, axillary temperature, body motion, position and shivering. The ISU communicates the data to the CIU for up linking to the AP's. The CIU consists of an RF link, an antenna and a battery, Figure 24. Personnel location is determined by the location of the AP's that pickup the ISU sensor signals which are communicated to the watchstander's console for display.

4.4 Information Exchange and Display

The publish/subscribe data transfer method was used to facilitate the exchange of information among a large number of AP's. A multicast feature within the publish/subscribe method is used because the same information is needed by all AP's. This method also allows the use of a debug and display processor and allows the data manager to handle communications between processes on each AP. The RSVP system information flow is shown in Figure 25. A demonstration RSVP system[11] was installed on the ex-USS *Shadwell* in Mobile, AL, in FY 2001. RSVP is deployed on *Shadwell* forward of frame 29 on the main deck, second deck and third deck, Figures 26, 27 and 28. Information gathered from the Intelligent Component Health Monitors (ICHM), the Environmental Sensor Clusters and the Personnel Health Monitors supplies information to the System Health Monitors (SHM). The RSVP data is forwarded to the watch station computer in the RSVP display area, Figure 29. Figures 30 and 31 depict the data display and information presentation.

The RSVP data fusion system environment must handle repetitive updates, single event transactions and reliable transfers across a range of ship compartments from AP to AP. Dynamic configuration changes occur as AP's leave and come back to the network as conditions change and data communication requirements increases and declines. Traditional client-server architectures route communications through central servers, but RSVP uses a publish-subscribe information exchange architecture because of the distributed data bases. Network Data Delivery Service (NDDS) is used for publish-subscribe functionality. NDDS implements publish-subscribe using real-time communications. Data fusion algorithms constantly monitor the data stream and notifies the watchstander's console of any off-nominal conditions. The man-machine interface (MMI) developed for the RSVP program employs off-the-shelf hardware and software. The MMI displays information about the status of the instrumented compartments for the demonstration. The format is interactive and intuitive and demonstrates an example of a virtual presence interface demonstrating crew interaction during the demonstration.



PSM Overview

RSVP

- System Components
 - Integrated Sensor Unit (ISU)
 - Communication Interface Unit (CIU)
 - Access Point

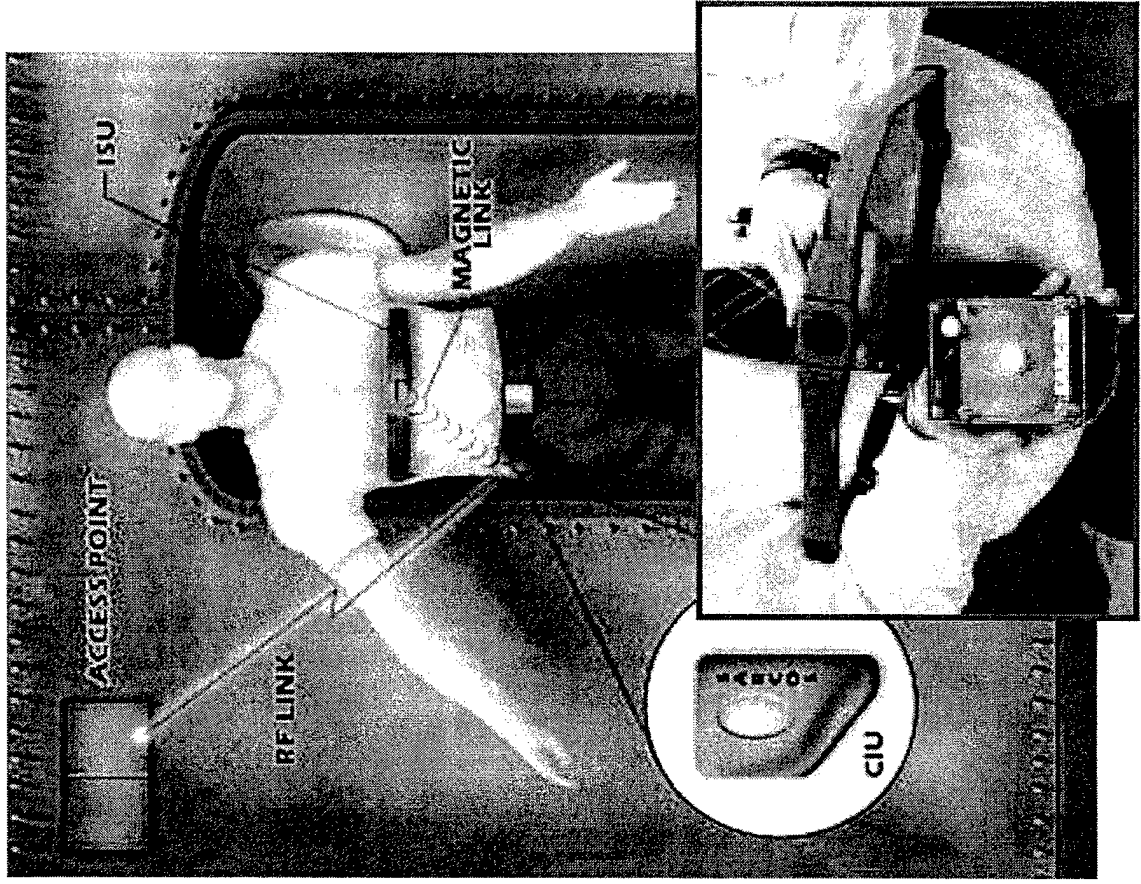
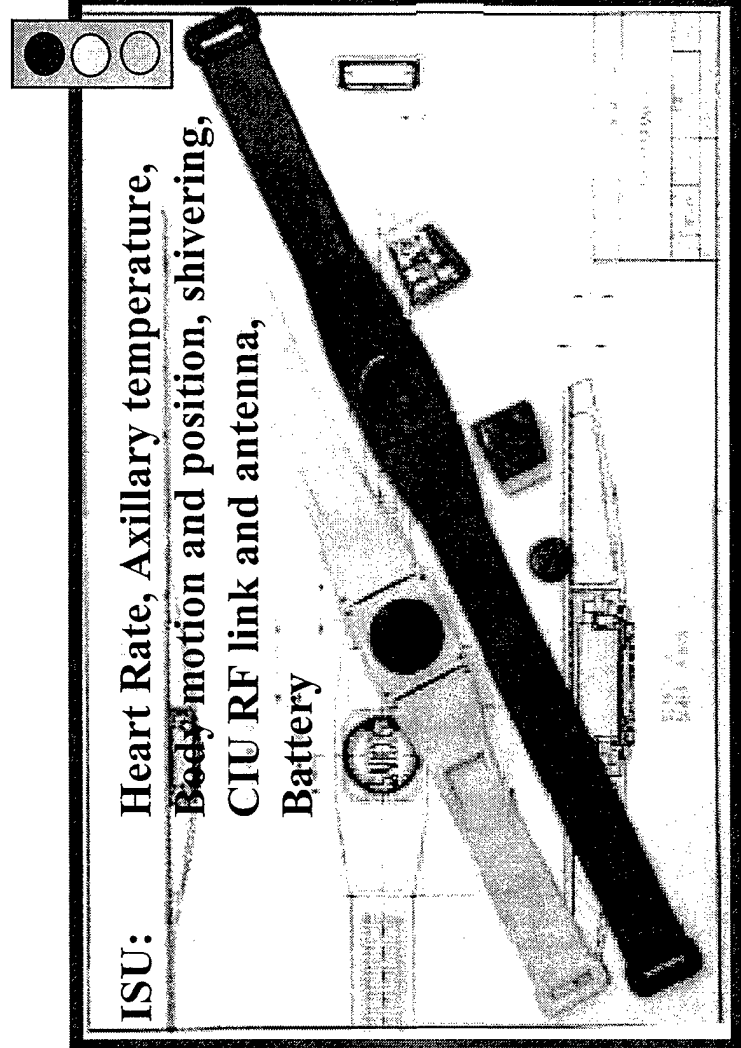
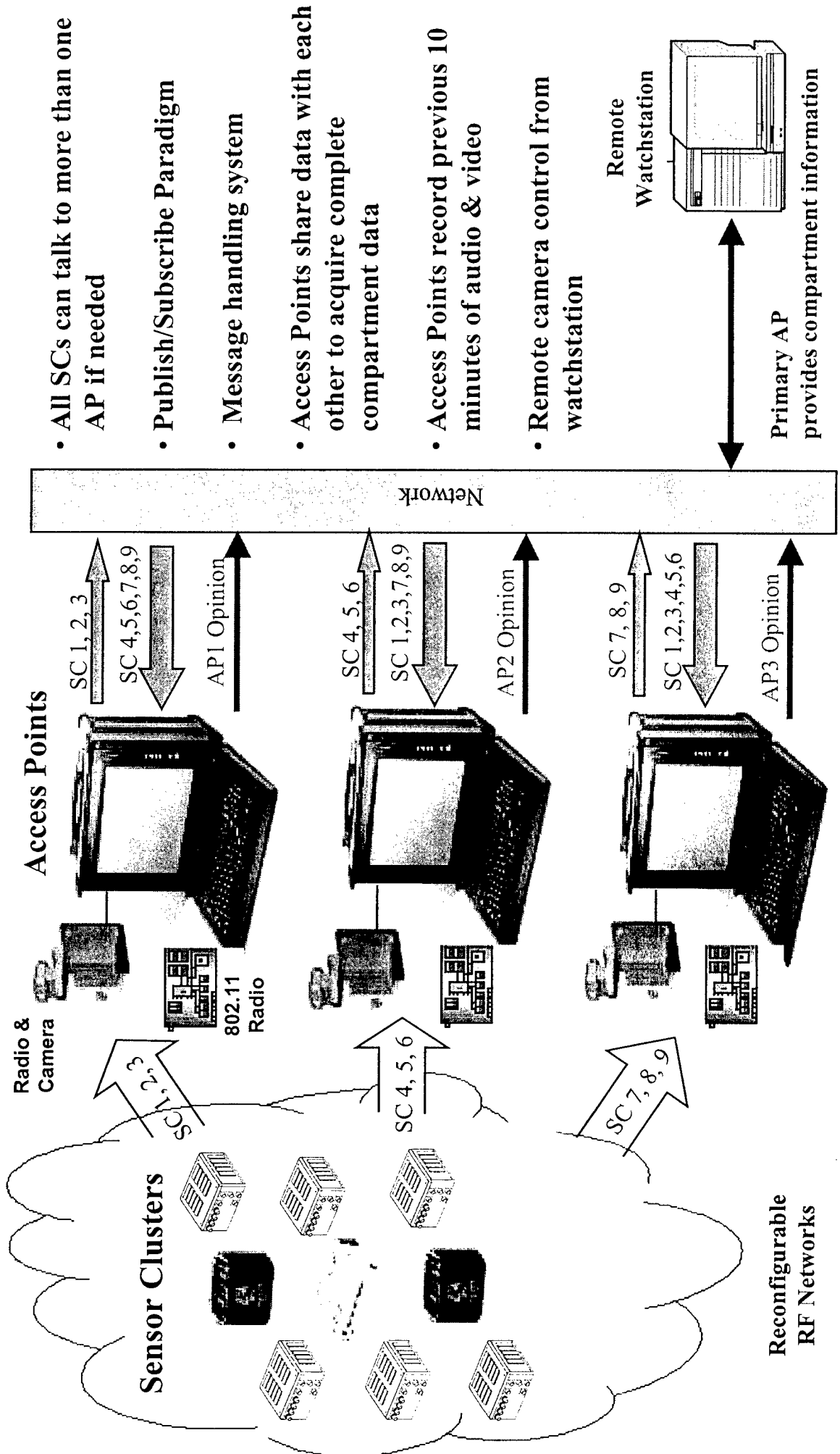
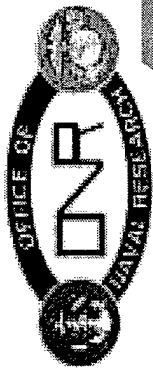

Figure 24. Personnel Status Monitor



- All SCs can talk to more than one AP if needed
- Publish/Subscribe Paradigm
- Message handling system
- Access Points share data with each other to acquire complete compartment data
- Access Points record previous 10 minutes of audio & video
- Remote camera control from watchstation

Figure 25. RSVP Information Flow



RSVP Installation

RSVP

Main Deck

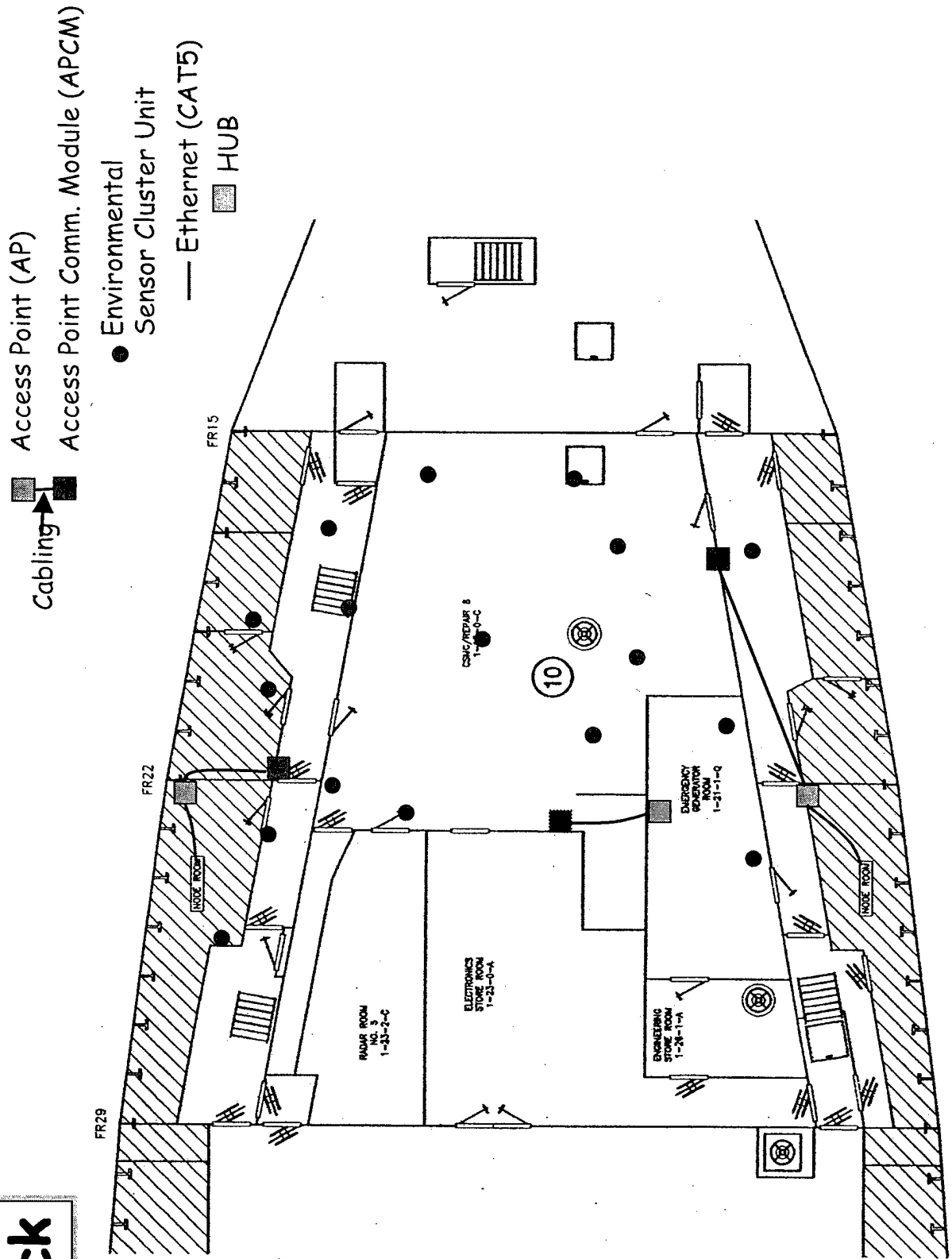

Figure 26. RSVP Configuration, Main Deck



RSVP Display Area

RSVP

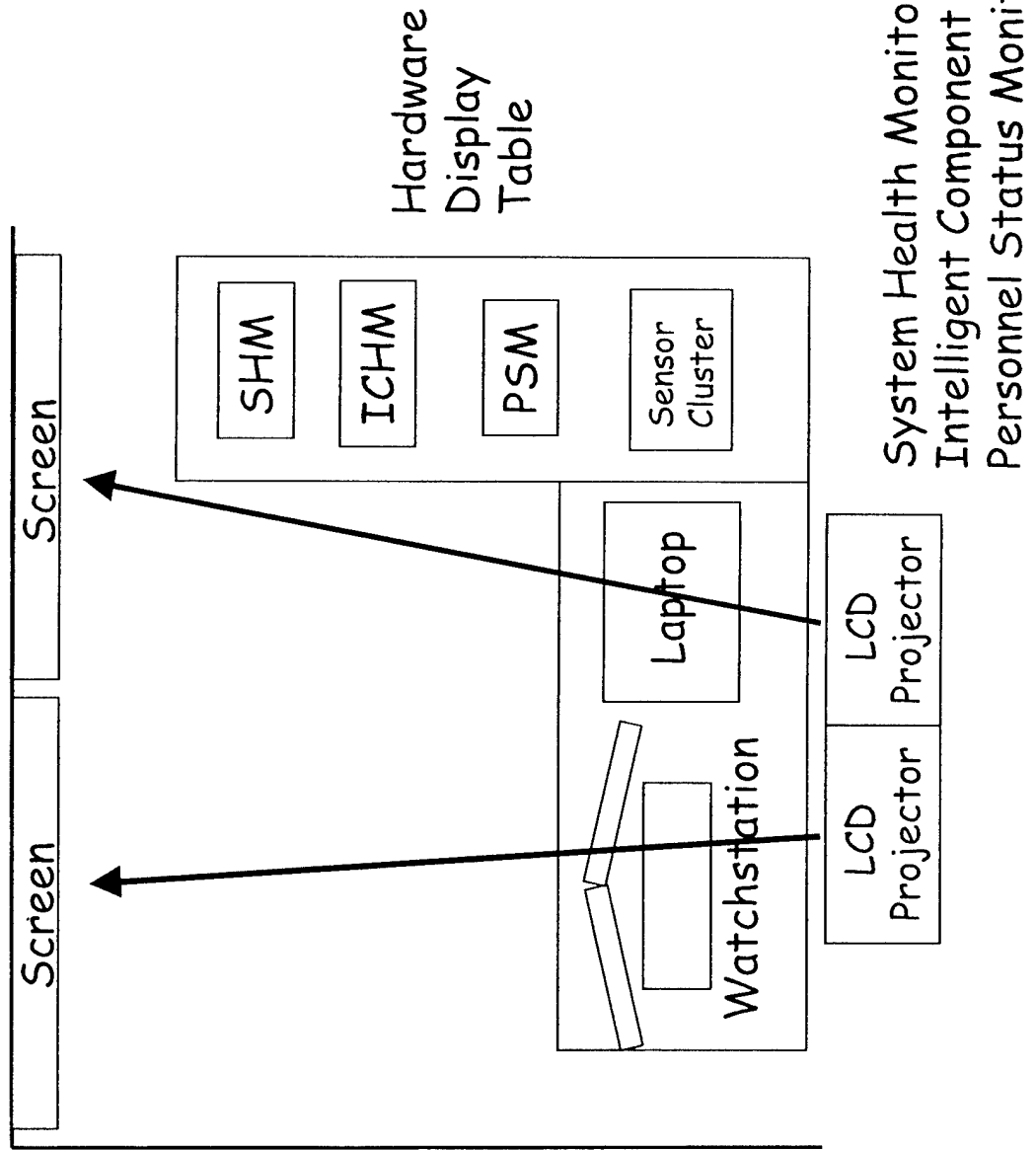

Figure 29. RSVP Display Area



CCS - Watchstation

RSVP

Station #1

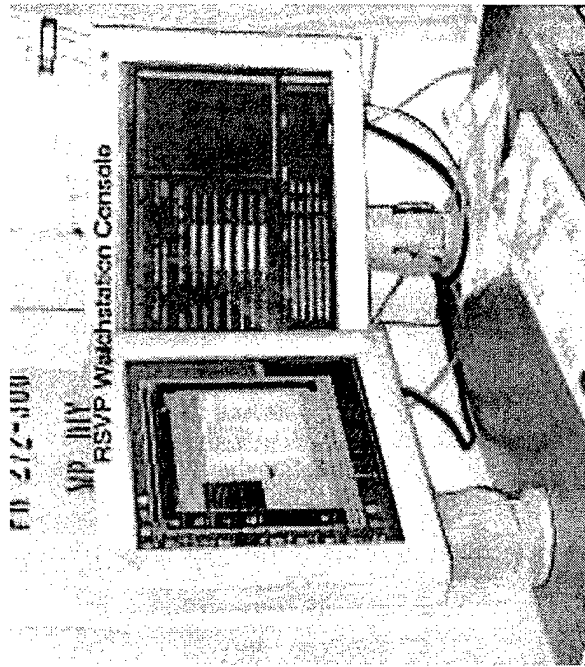
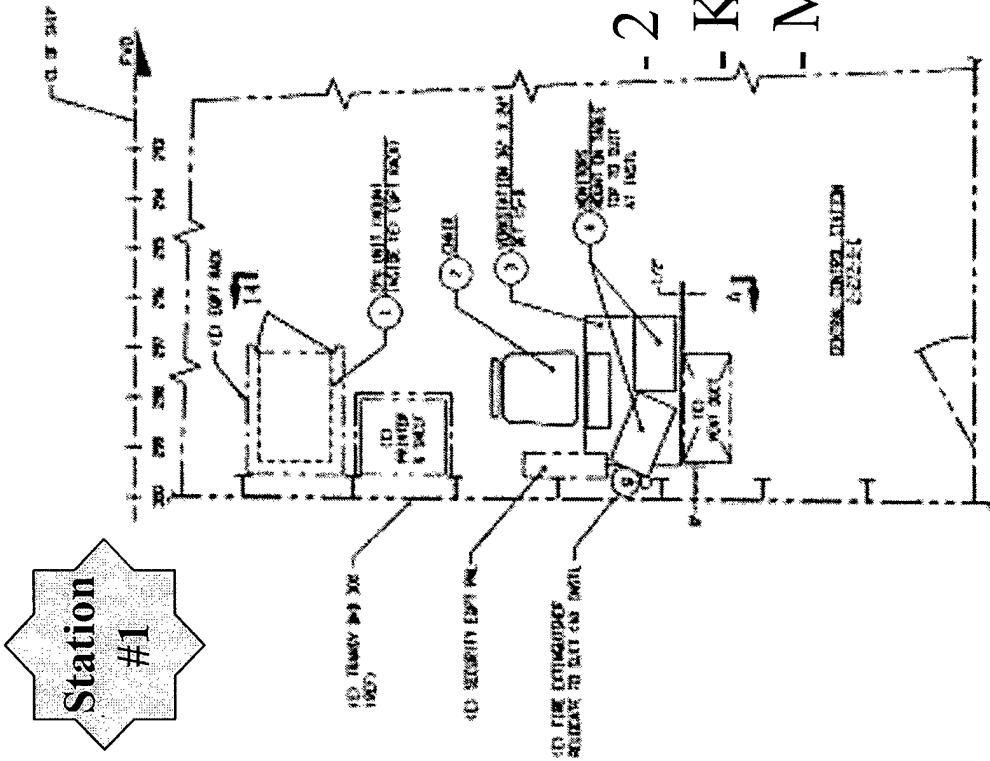

- 2 Flatpanel Displays
- Keyboard
- Mouse

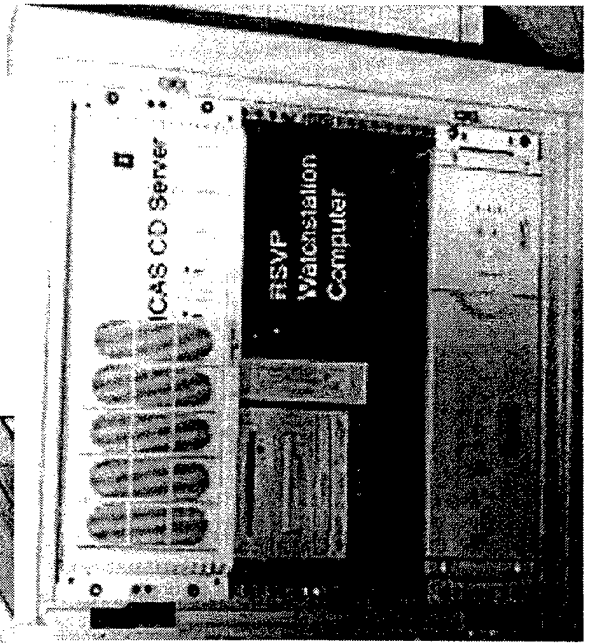

- CPU located in ICAS CD-Tower Rack
- UPS Located in MER #2
- Power from LDP 4-345-2 in MER #2

Figure 30. CCS Watchstation



Watchstation

RSVP

The screenshot shows the Main Operator Display (MOP) interface, which is divided into four main regions:

- Indication Region:** Displays a 3D model of the ship's hull and internal compartments. A top toolbar contains various icons for navigation and control. The top status bar shows the date and time: "17:20 January 08, 2001".
- Data Region:** Contains a menu with "OVERVIEW", "ALARMS", "CREW", "ENVIRON.", "MACHINE", "STRUCTURE", and "SYSTEM". Below the menu, it displays "AMR #1 Compartment" and "Page 1 of 1". The main area shows detailed information for "Alert 1: Fire" with symptoms, diagnosis, prognosis, impact, and actions.
- Alarm Region:** Displays a table of active alarms with columns for Problem, Time, Priority, Source, and Acknowledgement.
- Status Region:** Shows the current status of the system, including "03-15-0-V Corrosion Maint."

Problem	Time	Priority	Source	Acknowledgement
2-1E-0-E High Temp.	13:27	Medium	Vibration sensor	...
	13:03	High	Heart Rate sensor	...
	13:47	High	Multiple Temperature sensors	...
	11:09	Low	PSN communications	...
	2417	Low	Trends	...

- Multi-screen approach
- Commercial Software Package
- Inputs from End-User and domain experts
- Information NOT data

Figure 31. Main Operator Display

5.0 REFERENCES

1. "ex-USS *Shadwell* (LSD-15) – The Navy's Full Scale Damage Control RDT&E Test Facility," NRL Memorandum Report 6180-01-8576 of 24 August 2001
2. "Protected Voice Portable Communication System (PVPCS)MK 4 MOD ALL," Technical Report, NOSL R-474 of 1 January 1992
3. "Protected Voice Portable Communication System (PVPCS)MK 4," Technical Report NOSL R-446 of 1 July 1991
4. "Robust RF Tag Communication System for Shipboard Damage Control Automation," Proposal by Lucent Technologies Advanced Technology Systems, Alex Pidwerbetsky, July 16, 1997
5. "Ship Survivability Program - Sensor Suite in Support of RF Tag Demonstration on the ex-USS *Shadwell*," Sarcos, Inc, T. J. Petelenz PhD, May 8, 1998
6. "Wireless Sensor Data Communications - Overview," Lucent Technologies, Drs J. A. MacLellan and R. A. Shober, February 20, 1998
7. "Wireless MicroLan System Overview and Status," Bell Laboratories, Alex Pidwerbetsky, May 8, 1998.
8. "Wireless MicroLan Information Collection & Delivery," Lucent Technologies, G. G. Sutton, May 8, 1998
9. "Wireless MicroLan Graphical User Interface (GUI)," Lucent Technologies Presentation, Man Bae Kim, May 8, 1998
10. "Reduced Ship's Crew By Virtual Presence (RSVP) Advanced Technology Demonstration (ADT)," Draper Laboratory, Gary Schwartz, Systems Engineering Study, April 1999
11. "Reduced Ship's Crew by Virtual Presence (RSVP) Advanced Technology Demonstration (ATD) Program," LBES Test Plan, January 2001.
12. "RSVP Data Network Needs for Demo on ex-USS *Shadwell*," Draper Laboratory, G. Schwartz, July 20, 1999.

6.0 DEFINITIONS OF ABBREVIATIONS

ATD	Advanced Technology Demonstration
AP's	Access Points
AM	Amplitude Modulated
CAS	Consolidated Antenna System
CGI	Common Gateway Interface
CIU	Communications Interface Unit
COTS	Commercial Off-The-Shelf
CW	Continuous Wave
DARPA	Defense Advanced Research Projects Agency
DC ARM	Damage Control Automation For Reduced Manning
DPL	Digital Private Line
EEPROM	Electrically Erasable Programmable Read Only Memory
GUI	Graphical User Interface
HTTP	Hypertext Transfer Protocol
IC	Interior Communications
IC&D	Information Collection & Delivery
ICAS	Integrated Condition Assessment System
ICHM	Intelligent Component Health Monitor
ILS	Integrated Logistics Support
IR	Infrared
ISU	Integrated Sensor Unit
LAN	Local Area Network
MEMS	Microelectromechanical System
MMI	Man Machine Interface
NDI	Non Developmental Item
NDDS	Network Data Delivery Service
OS	Operating System
PMM	Power Management Module
PMS	Periodic Maintenance Schedule
PSM	Personnel Status Monitor
PVPCS	Protected Voice Portable Communication System
RADIAX	Slotted Coax Cable Combination Transmission & Antenna
RAM	Random Access Memory
RF	Radio Frequency
RSM	Remote Speaker Microphone
RSVP	Reduced Ships Crew By Virtual Presence
RTL	Radiating Transmission Line
SHM	System Health Monitor
UNIX	Operating System
WIM	Wireless MicroLan

APPENDIX A

WIRELESS RF TAG (MICROLAN) POWER UP AND OPERATION PROCEDURE

Wireless RF Tag (MicroLan) Power-up and Operation

1. Server Login and password: (Tecra 720 CDT "UNIX" Ctrl Rm)Telenet 45.46.100.197

<u>LOGIN:</u>	<u>PASSWORD:</u>		
root	wim9600	(All lower case)	Prompt #
webmaster	wim9600	(All lower case)	Prompt \$

2. GUI Platform Login and Password (Satellite 320cdr "Win95") Control Room

<u>LOGIN:</u>	<u>PASSWORD:</u>		
wimtester	wimtester	(Not case sensitive)	Reply OK to any Messages

3. Network Computer Login and Password: (Libretta 50 CT "Win 95") Turn on 5 Wavelan Stations

<u>LOGIN:</u>	<u>PASSWORD:</u>	
wimtester	wimtester	(Not case sensitive)

4. Server Filesystem & Webmaster Directories

a. Login as webmastr (no "e" in spelling)

b. hints:

```
ls -l  
find . - print
```

c. Key directories (relative to Home webmastr)

wim (System build and reconfig) .txt file for config Modifile ()

www/sws/cgi.bin	(Webserver Query Programs)
www/sws/htdocs	(Webserver Home)
www/sws/htdocs/wim/databases	(Databases directory)

5. Shutting Down and Booting The Server

(a) Shut Down (After Shutting Down Interrogators)

Either from the Server Laptop (command line login) or via telenet:

1. Login as Root (if via telenet, login as webmastr, sv to root, cd/

2. Run the following command:

Shutdown -i0 -g0 -y (lower case except "0" (zeros))

when down depress the power switch before reboot). If vis telenet, depress power switch when screen goes blank.

(b) Reboot - just operate power button

(c) Power Loss

(1) server will continue until battery is discharged.

(2) when power returns system will reboot

(3) all server daemons will automatically restart

6. Booting The GUI

(a) standard Win95 platform

(b) double click the wim gui

- | | | | |
|-----|--------------------------------|---|------------------------------------|
| (c) | <i>Control Bar</i>
"Window" | → | <i>Response click</i>
Main Deck |
| (d) | "Window" | → | File vertical |
| (e) | "Get data" | → | Periodic download |

(f) Full screen main deck then back to refresh

(g) Cannot modify icons from GUI

APPENDIX B

Ex-USS *Shadwell* WIFCOM RADIAX ANTENNA

CABLE ROUTING DIAGRAMS

GROUP I

Cable Labels

R-RA-501-09

R-RA-501-10

R-RA-501-11

R-RA-501-CONT.

(Pages B-3 to B-5)

29

36

43

50

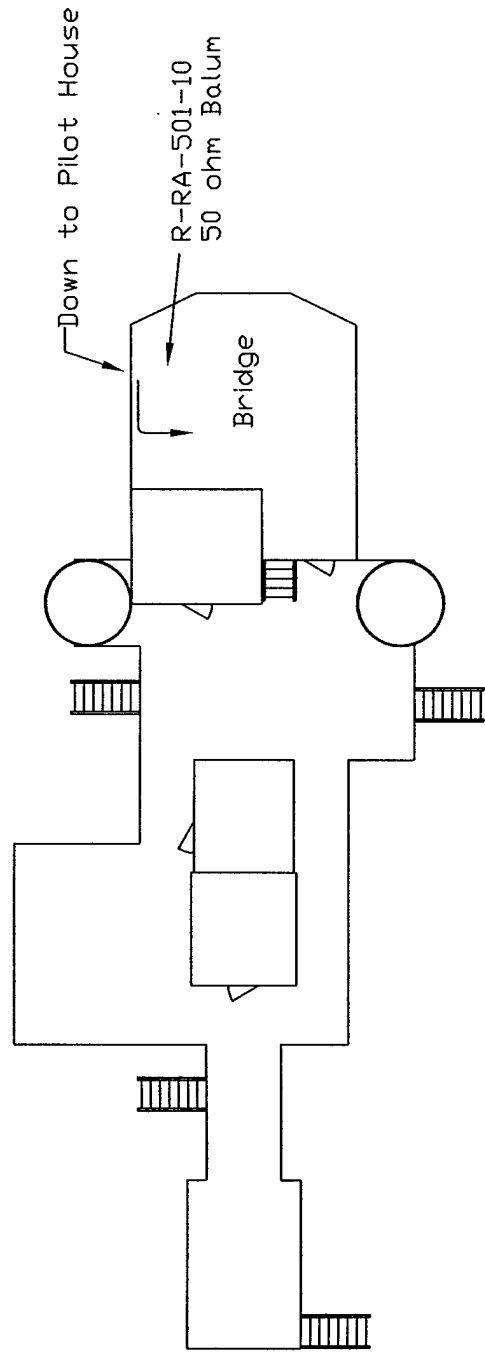

04 LEVEL

B-3

50 43 36 29 22

FWD

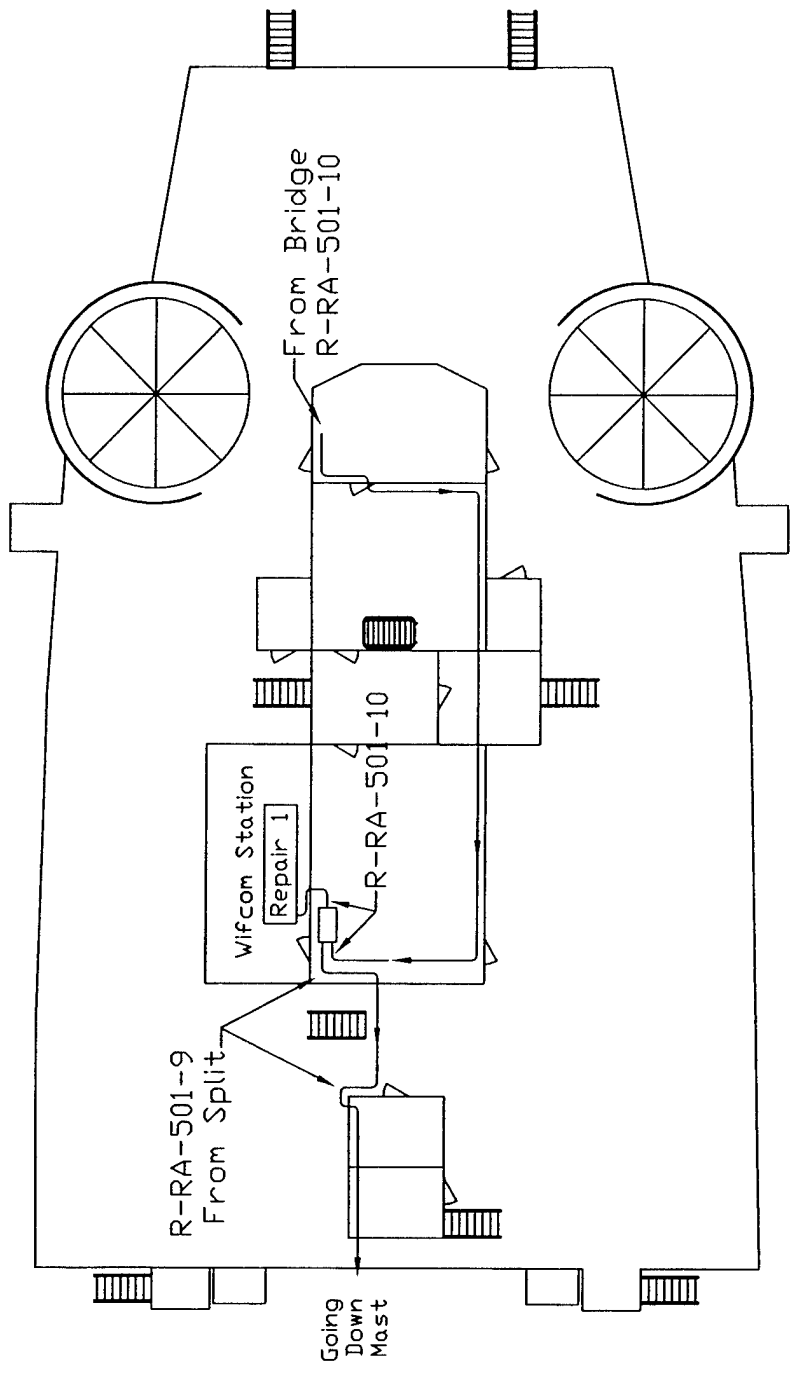

03 LEVEL

50 43 36 29 22 15

FWD

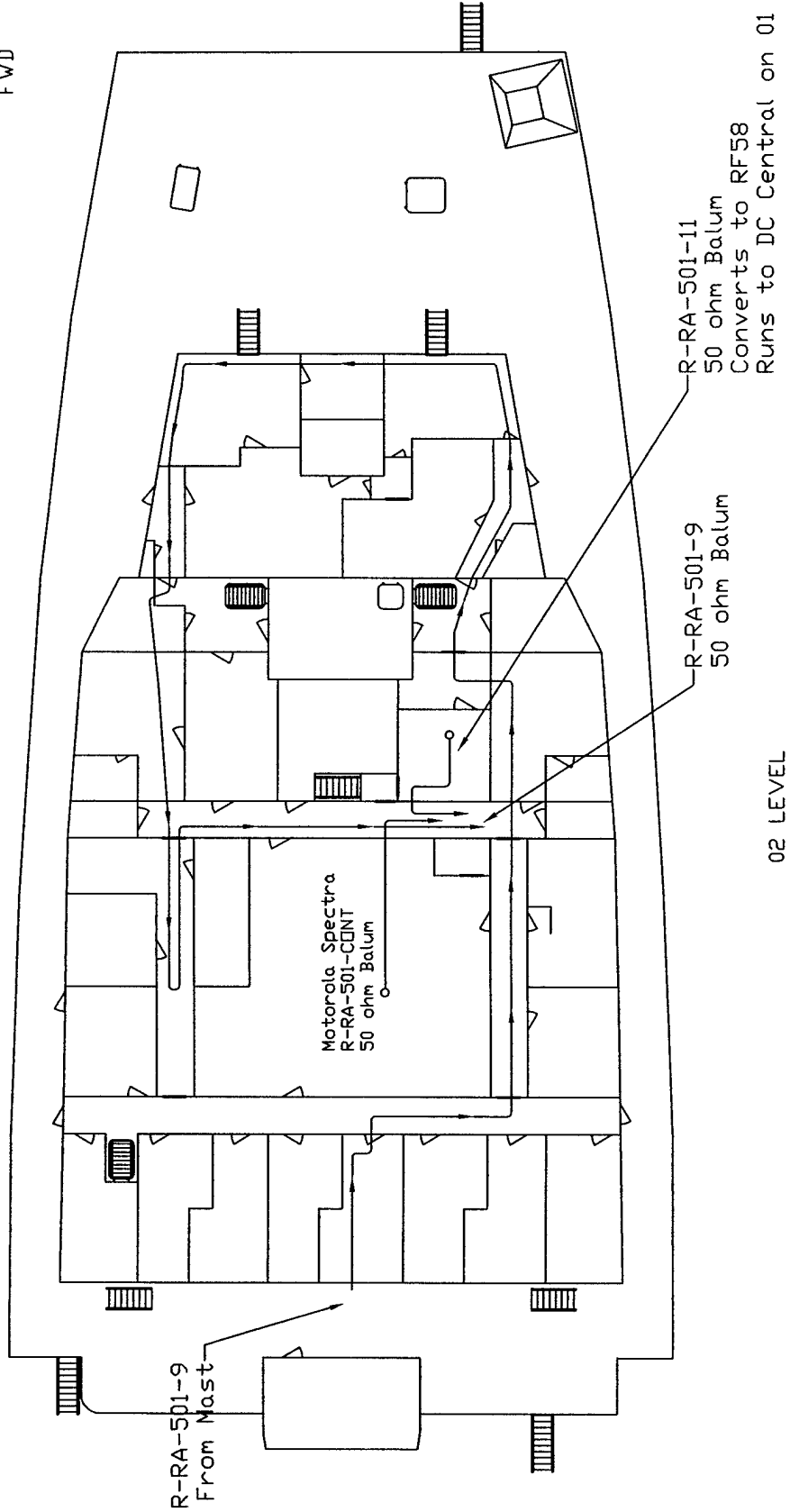

02 LEVEL

GROUP II

Cable Labels

R-RA-501-DCC

R-RA-501-1

R-RA-501-2

R-RA-501-2-1

R-RA-501-3

R-RA-501-10

R-RA-501-3A

R-RA-501-6

R-RA-501-7

(Pages B-7 to B-9)

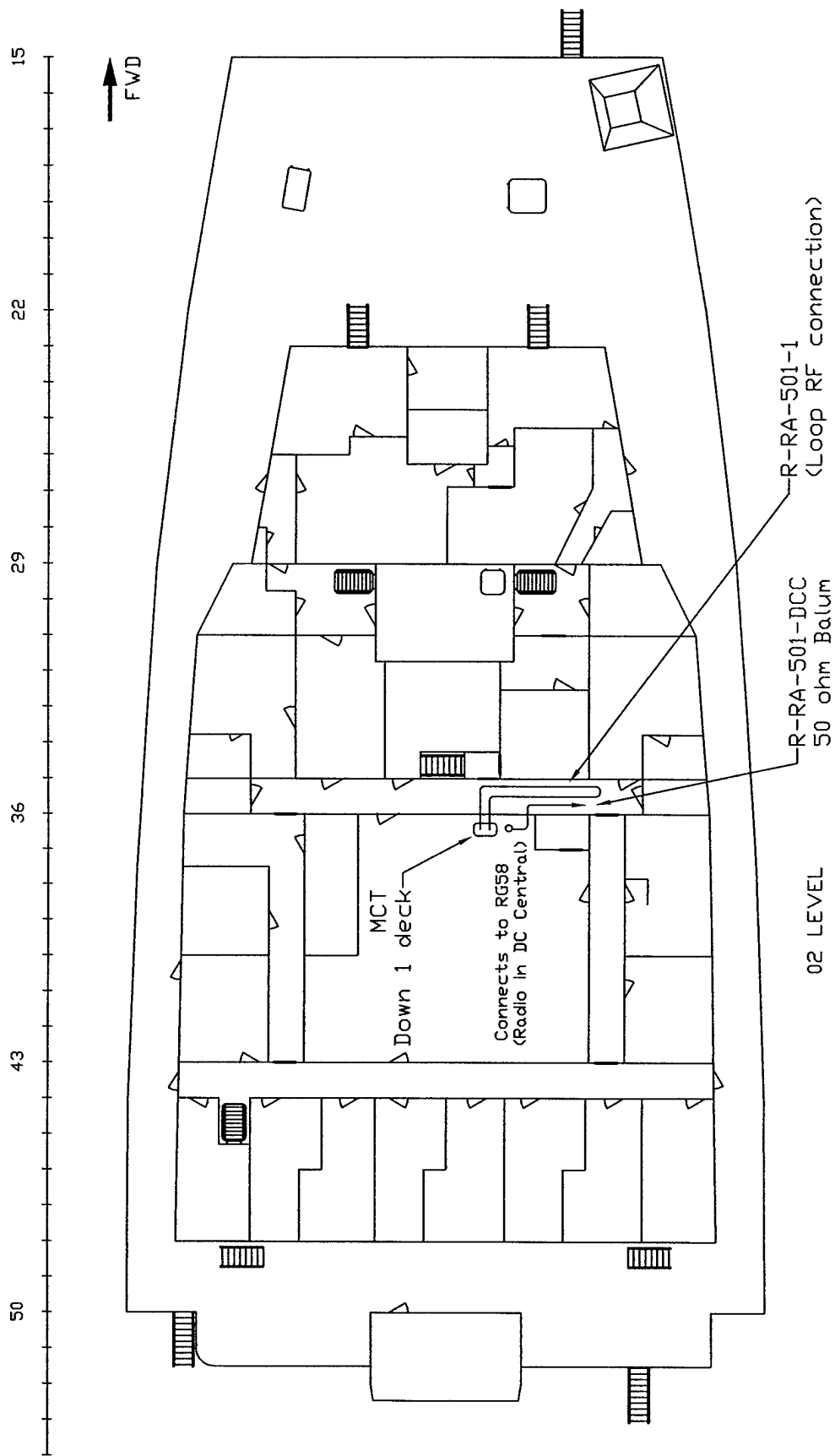

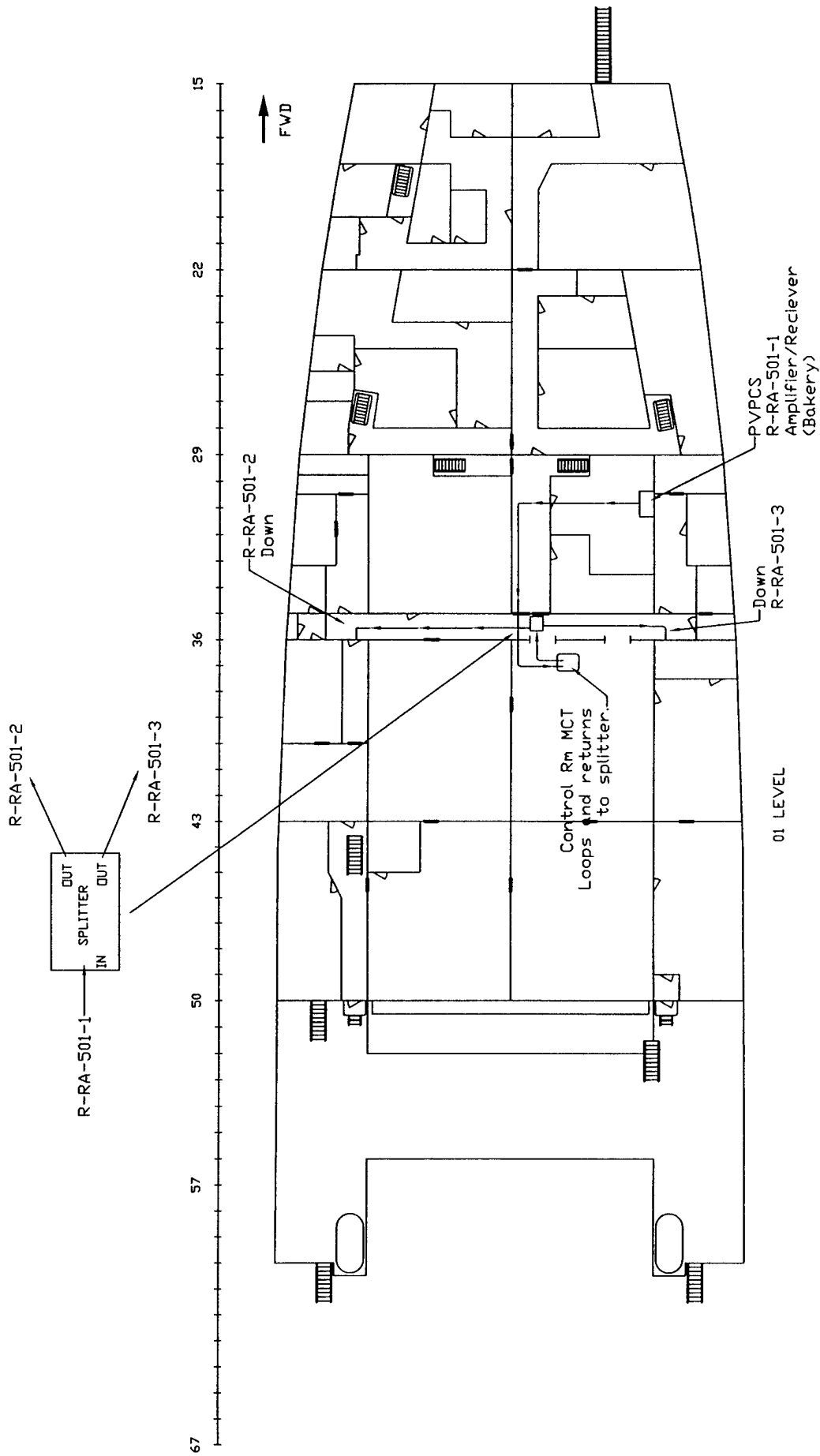

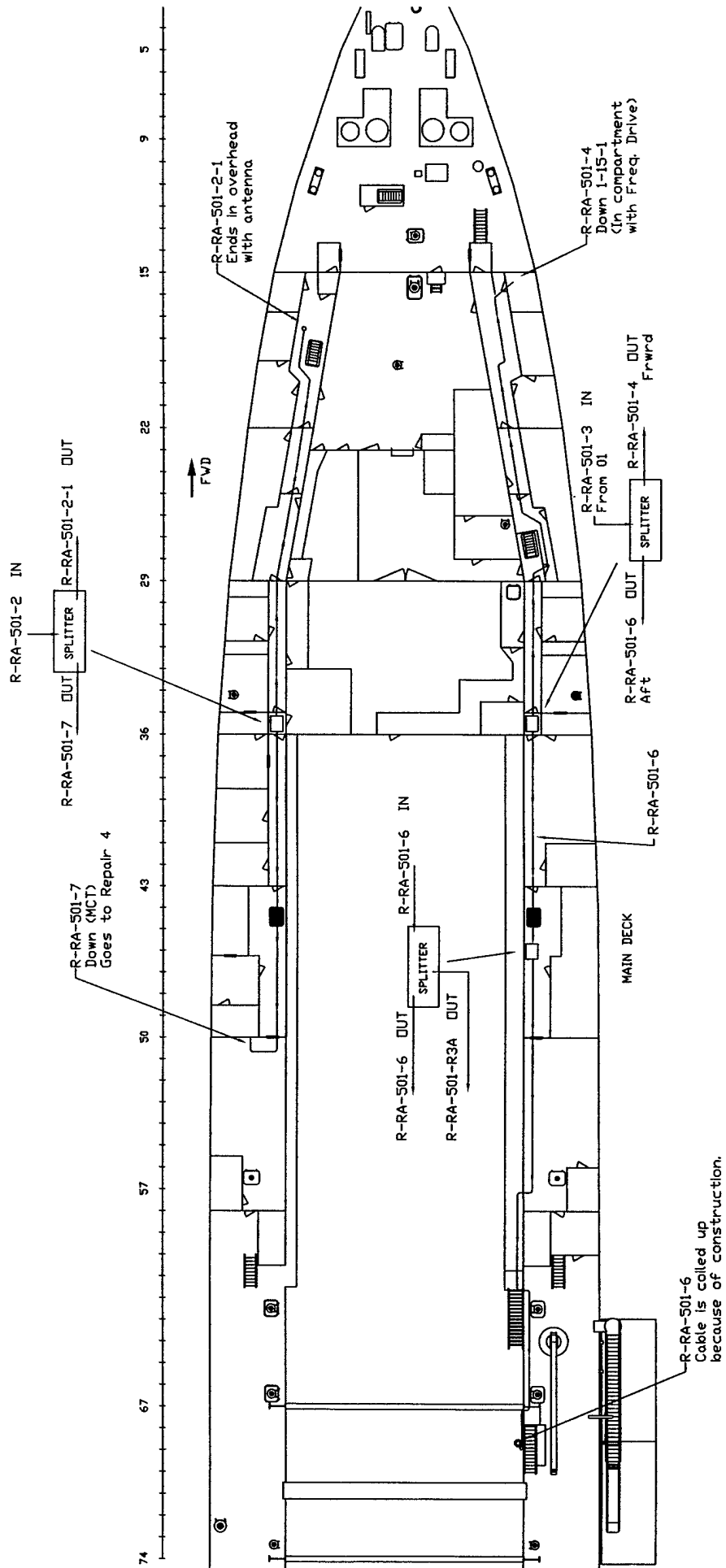

GROUP III

Cable Labels

**R-RA-501-R2B
R-RA-501-R2C
R-RA-501-R2D
R-RA-501-4**

(Pages B-11 to B-13)

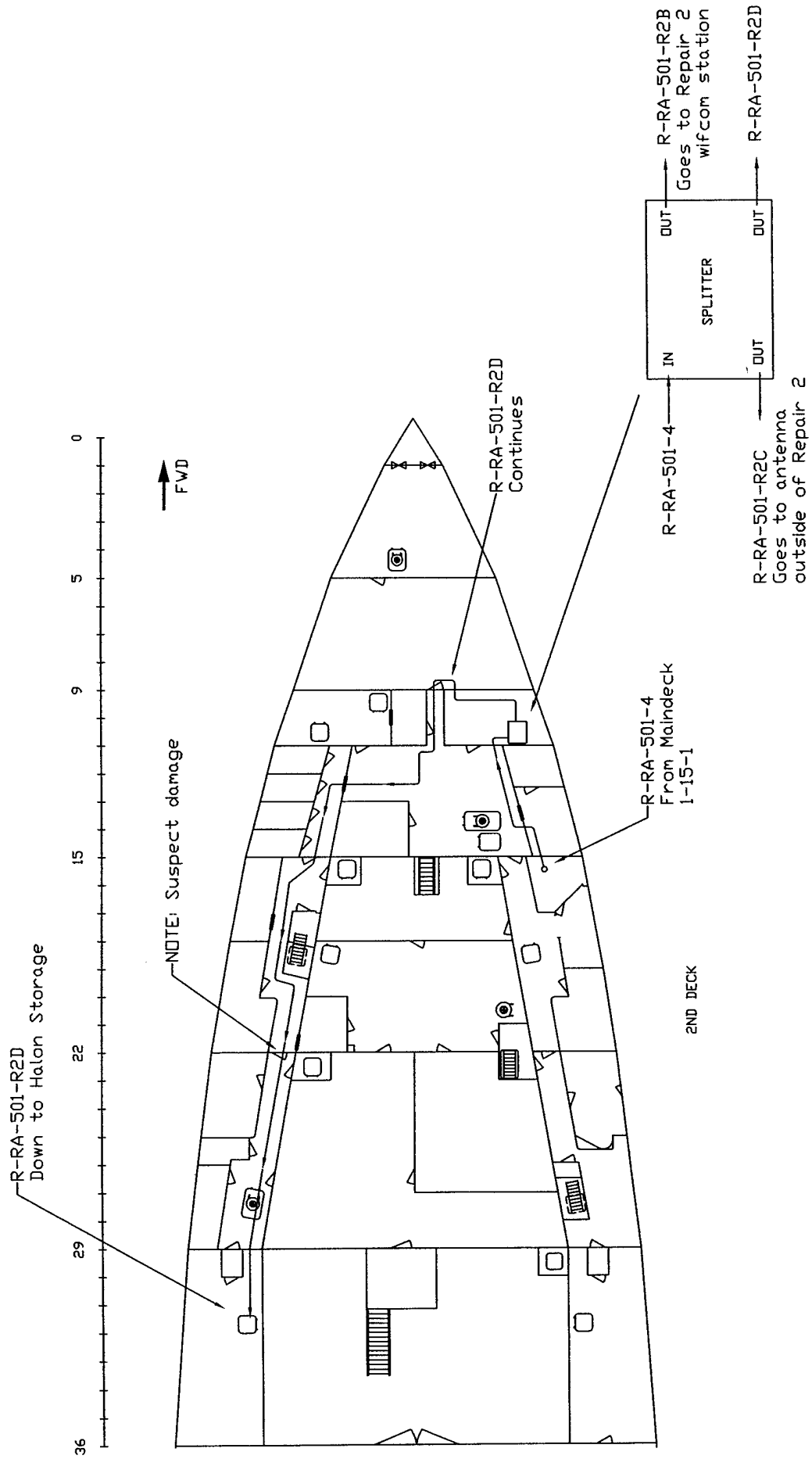

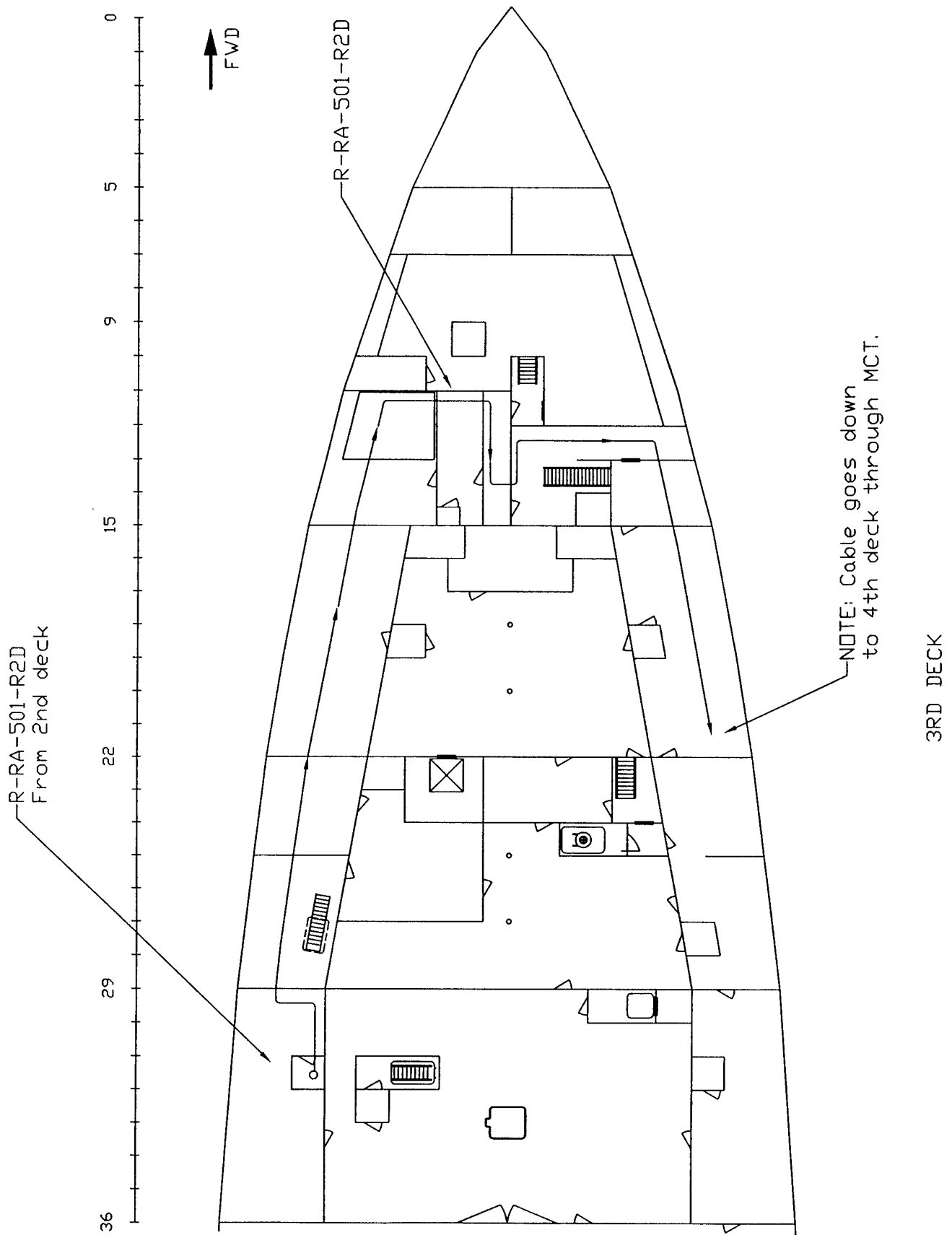

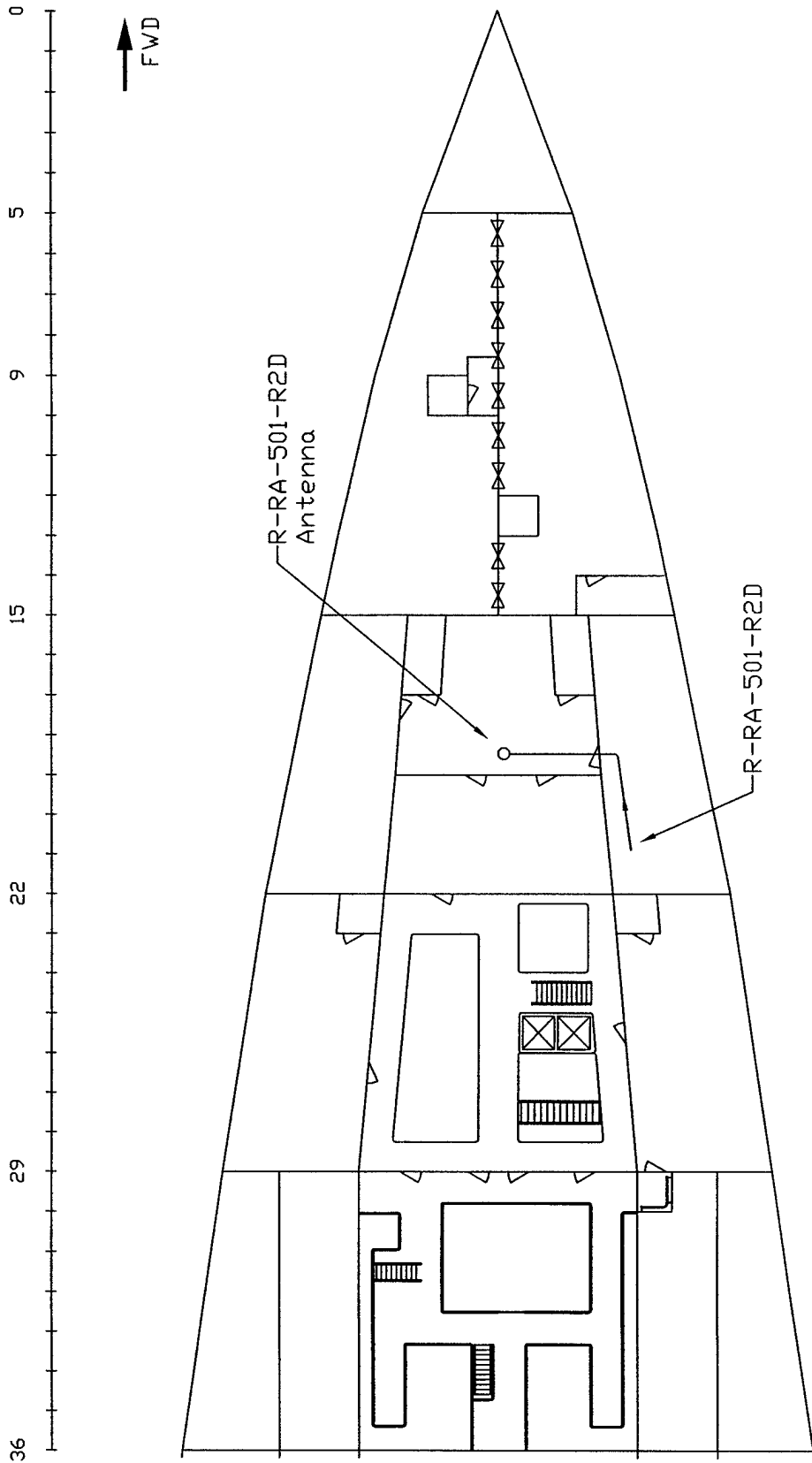

4TH DECK

GROUP IV

Cable Labels

R-RA-501-7

R-RA-501-8

(Pages B-15 to B-17)

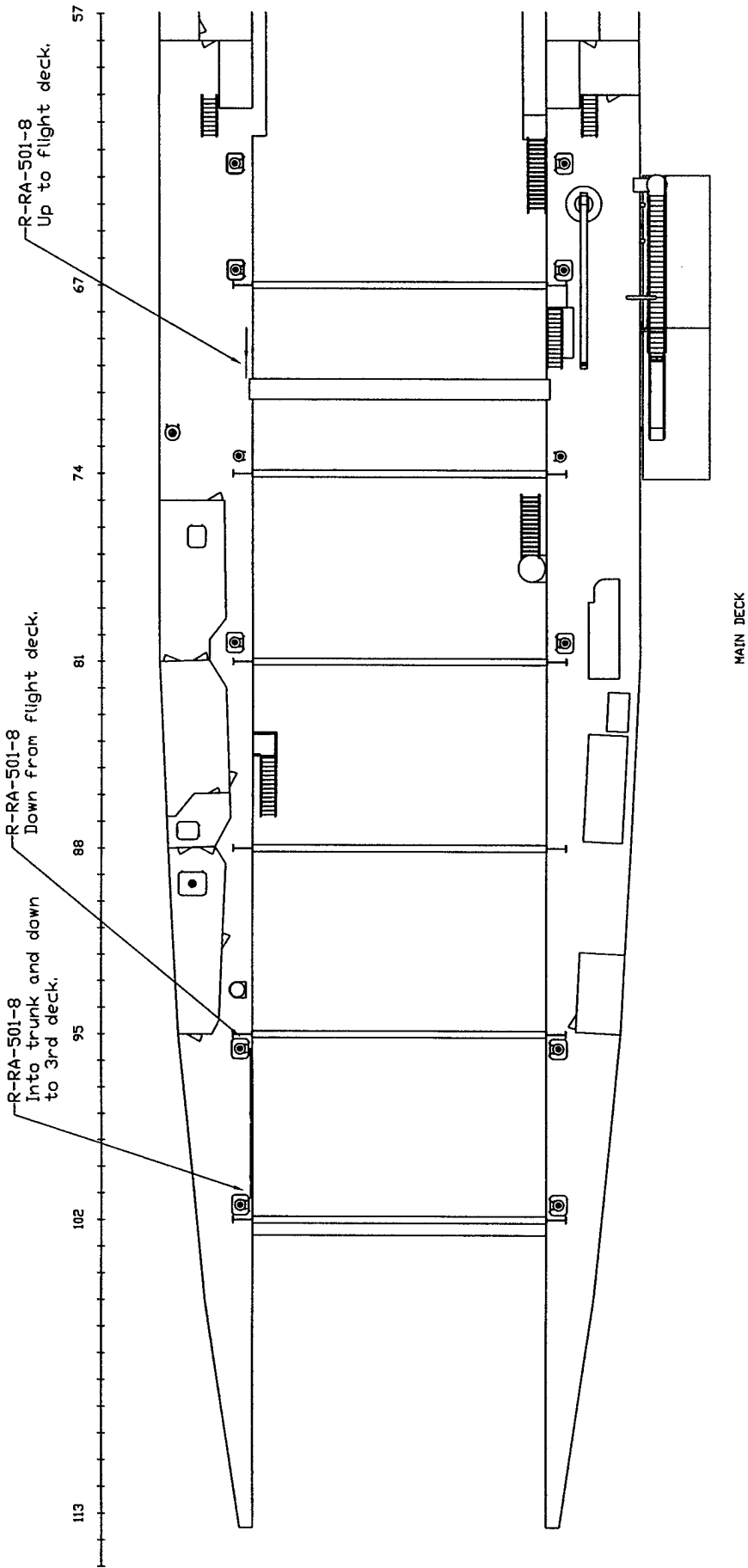

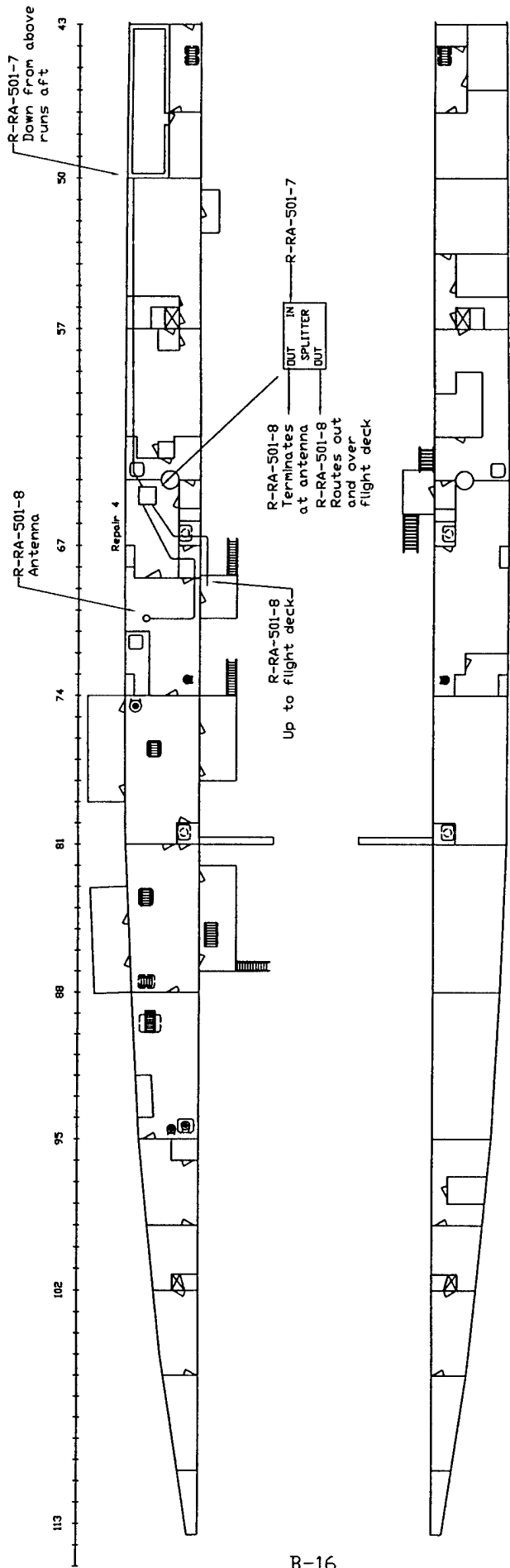

R-RA-501-8
From Repair 4
Terminates at
antenna

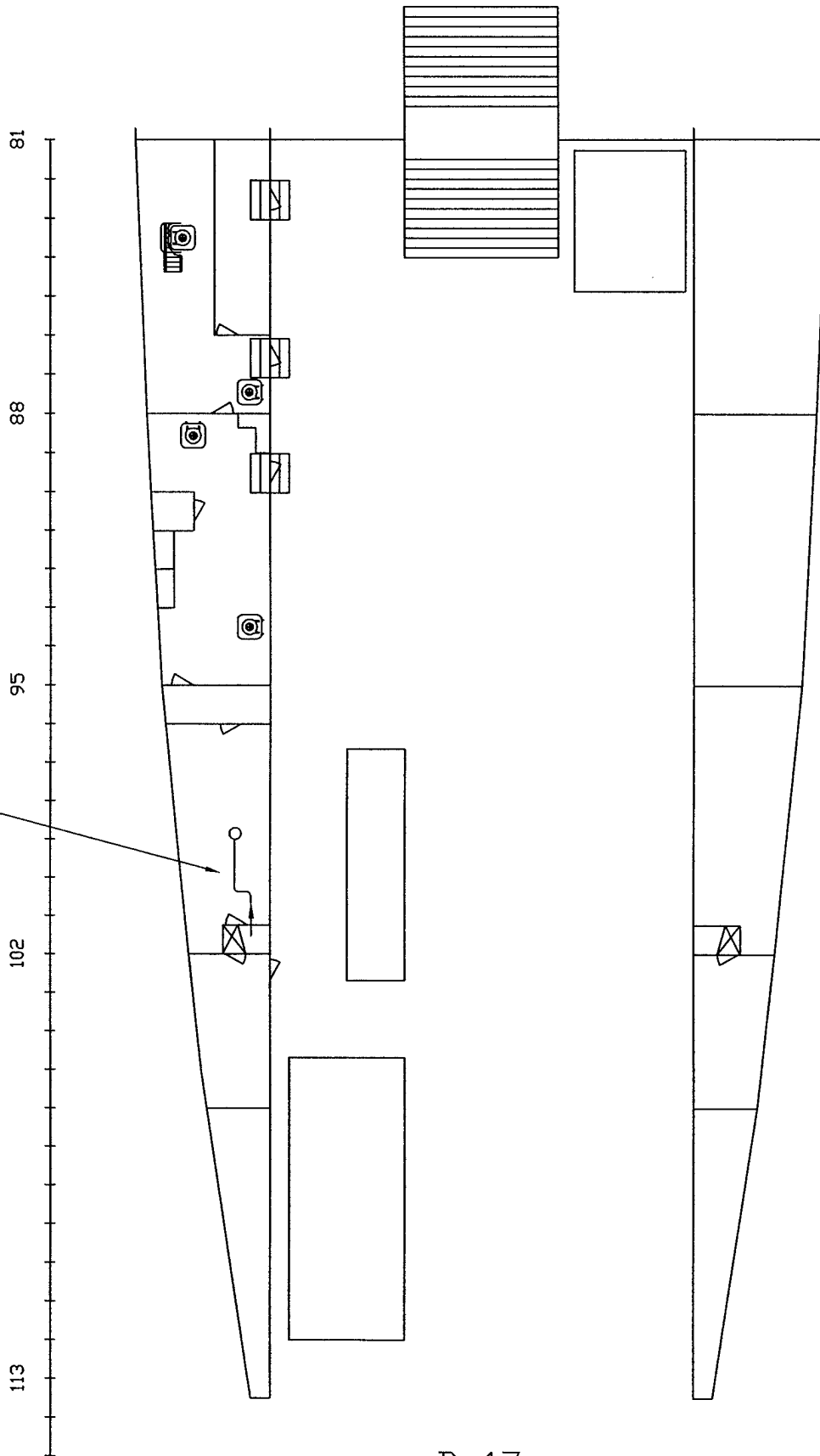

3RD DECK

GROUP V

Cable Labels

**R-RA-501-R3A
R-RA-501-R3B
R-RA-501-R3C
R-RA-501-R3D
R-RA-501-R3D1
R-RA-501-R3D2**

(Pages B-19 to B-23)

0
5
9
15
22
29
36
43
50

FWD
↑

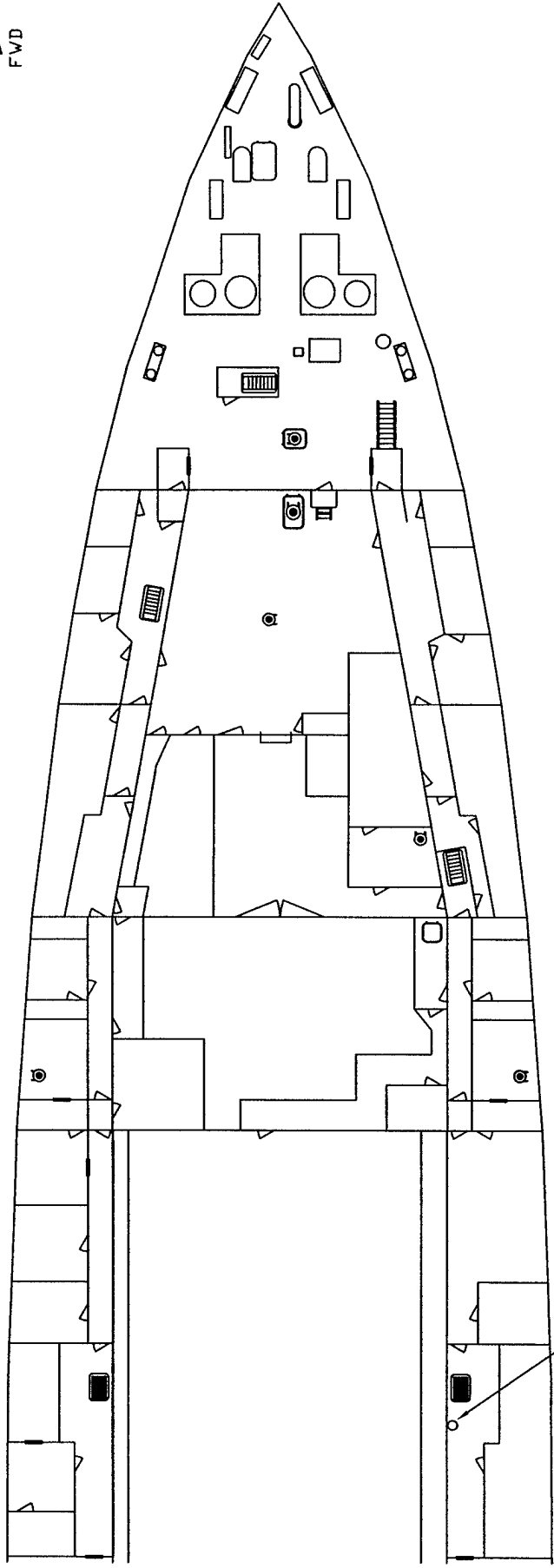

MAIN DECK

R-RA-501-R3A
Down to Repair 3

B-19

74 67 57 50 43 36 29

FWD

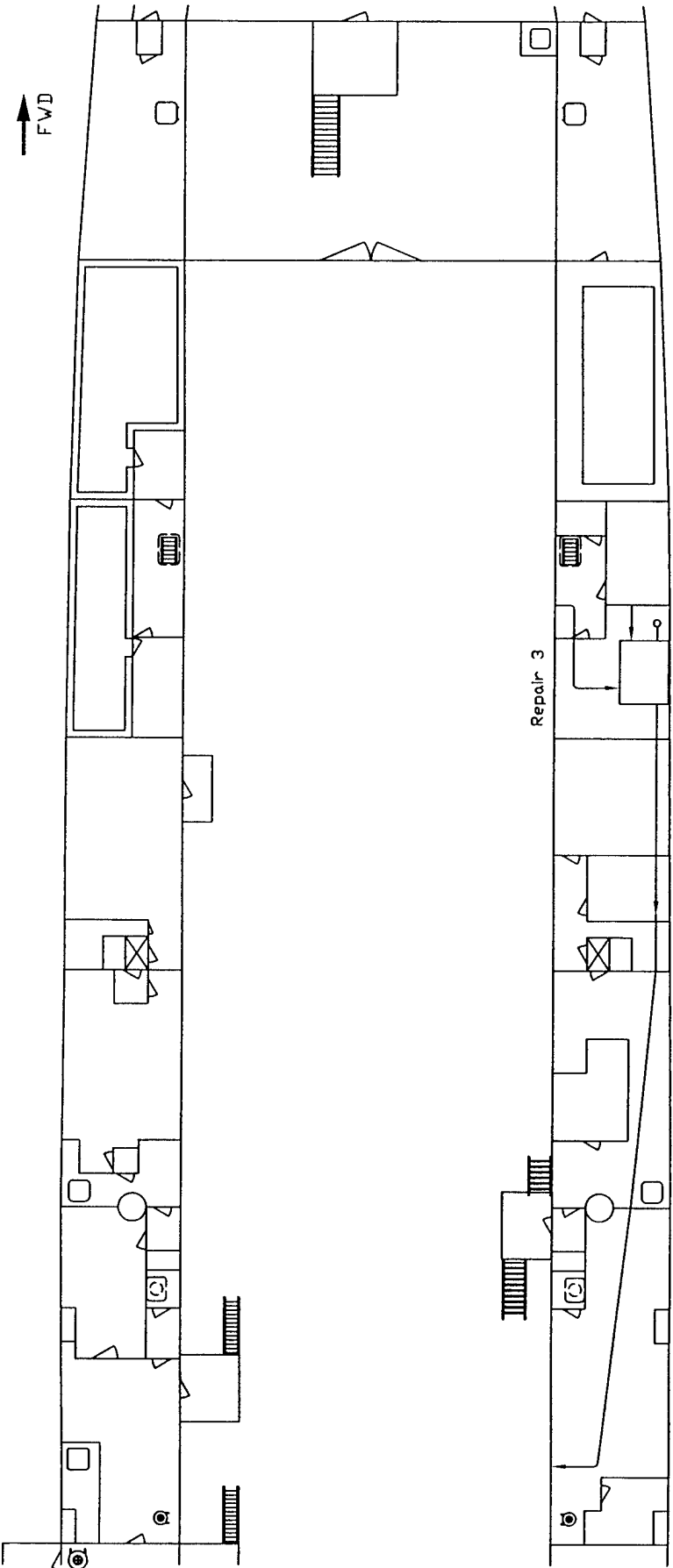

2ND DECK

R-RA-501-R3A
From 1-46-1

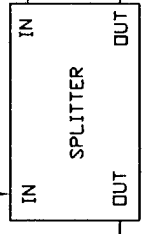

R-RA-501-R3B
To DC Wifcom

R-RA-501-R3D
Aft and down
to Eng. Rm.

R-RA-501-R3C
To antenna inside
Repair 3

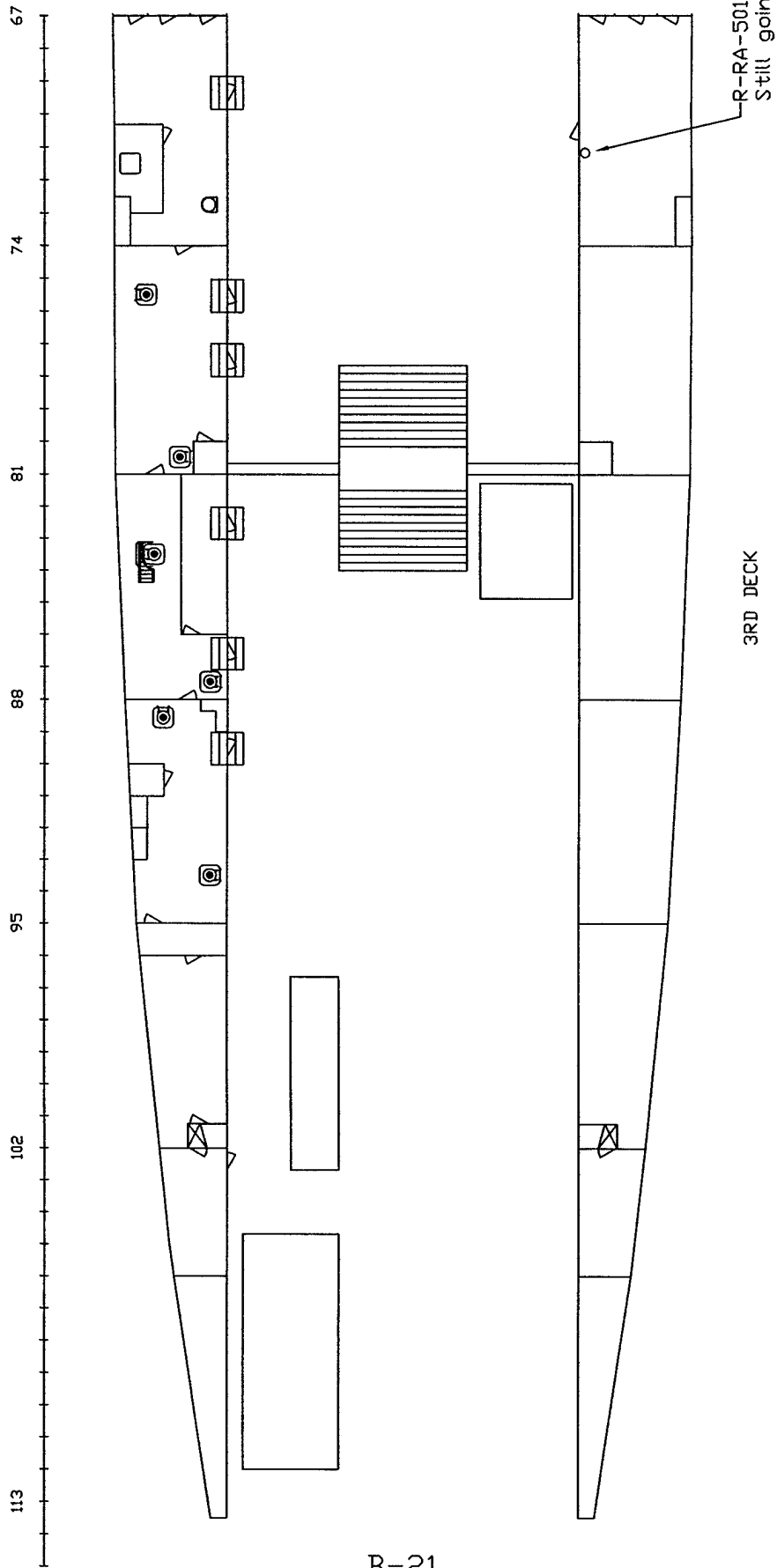

B-21

74 67 57 50

FWD

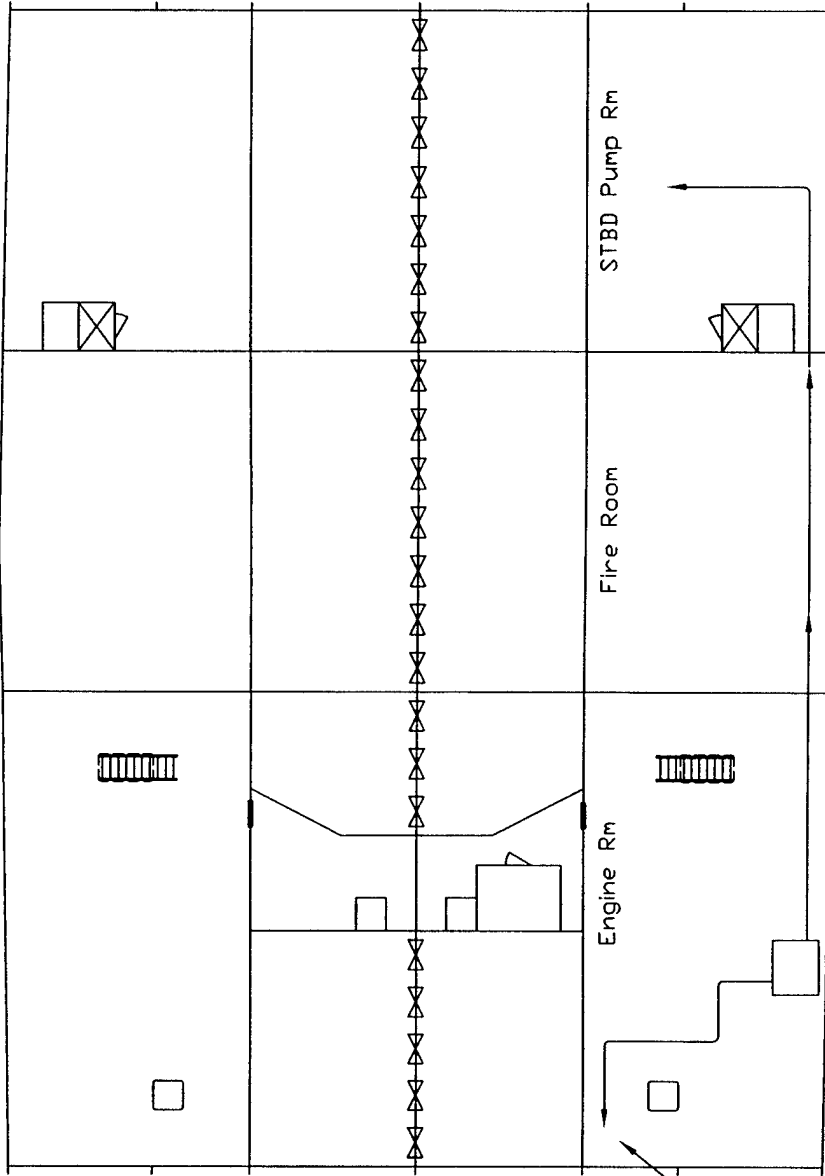

4TH DECK

R-RA-501-R3D1
Down

R-RA-501-R3D1

R-RA-501-R3D2



81 74 67 57 50

FWD

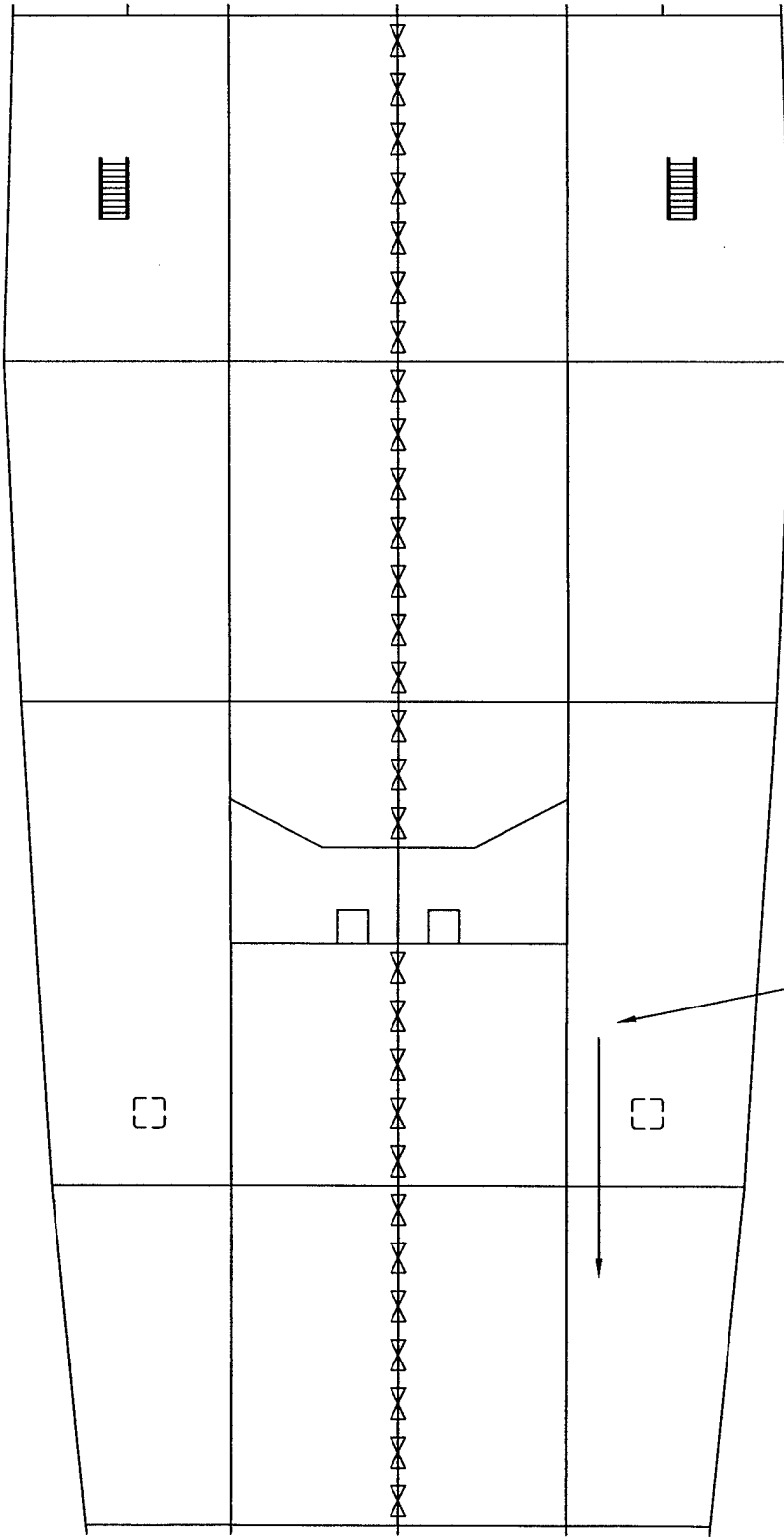

HOLD DECK

R-RA-501-R3D1
From Repair 3

B-23