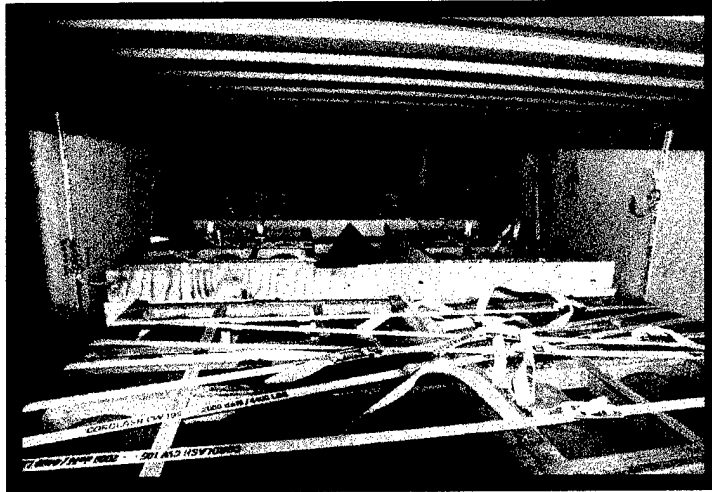


**FINAL REPORT  
JULY 2002**

**REPORT NO. 01-22**

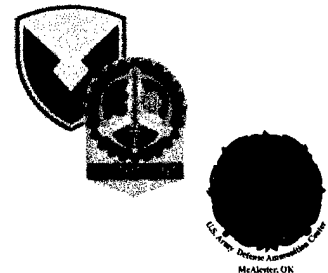


**CORDSTRAP™ W/MK-82 BOMBS,  
TP-94-01,  
“TRANSPORTABILITY TESTING PROCEDURES”**

**Prepared for:**

**Distribution Unlimited**

U.S. Air Force  
Air Expeditionary Battlelab  
360 Gunfighter Ave  
Mt Home AFB, ID 83648



**VALIDATION ENGINEERING DIVISION  
MCALESTER, OKLAHOMA 74501-9053**

**20020805 180**

## **AVAILABILITY NOTICE**

A copy of this report will be furnished each attendee on automatic distribution. Additional copies or authority for reprinting may be obtained by written request from:

Director  
U.S. Army Defense Ammunition Center  
ATTN: SOSAC-DEV  
1 C Tree Road, Bldg. 35  
McAlester, OK 74501-9053

Reports may also be downloaded or viewed in PDF format from our web site at:

<http://www/dac.army.mil/DEV/TestReports>

## **DISTRIBUTION INSTRUCTIONS**

Destroy this report when no longer needed. Do not return.

\*\*\*

Citation of trade names in this report does not constitute an official endorsement.

\*\*\*

The information contained herein will not be used for advertising purposes.

**REPORT NO. 01-22**  
**CORDSTRAP w/MK82 500-POUND BOMBS**  
**TP-94-01, TRANSPORTABILITY TESTING PROCEDURES**

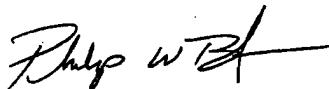
**JULY 2002**

**ABSTRACT**

The U.S. Army Defense Ammunition Center (DAC), Validation Engineering Division, (SOSAC-DEV), was tasked by the USAF Air Expeditionary Battlelab to conduct transportability testing and to validate Cordstrap™ material as an alternative to using wood for blocking and bracing the MK-82 500-pound bombs in an end-opening 20-foot-long intermodal container. Based on our review and testing, the Cordstrap™ material was not effective as an alternative to wood for restraint of the MK-82 bombs in an end-opening intermodal container.

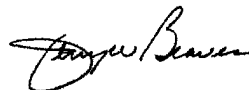
During testing, the Cordstrap™ either stretched excessively or broke which allowed the payload to move. Also, the airbags that were used during initial testing lost pressure due to temperature changes and would not hold the load tightly. The Cordstrap™ system is dependent on the intermodal container having lashing rings located along the floor and roof. Not all intermodal containers have lashing rings; and, therefore, the system could not be used in containers without rings. Additionally, the Cordstrap™ material was not effective as an alternative to wood since considerable wood dunnage was still required to block and brace the payload. Cordstrap™ material could not be used as a forward bulkhead and required excessive time and labor to install.

Prepared by:



**PHILIP W. BARICKMAN**  
Lead Validation Engineer

Reviewed by:



**JERRY W. BEAVER**  
Chief, Validation Engineering Division

U.S. ARMY DEFENSE AMMUNITION CENTER  
VALIDATION ENGINEERING DIVISION  
MCALESTER, OK 74501-9053

REPORT NO. 01-22

CORDSTRAP™ W/MK-82 BOMBS  
TP-94-01, "TRANSPORTABILITY TESTING PROCEDURES"

TABLE OF CONTENTS

| PART                                       | PAGE NO. |
|--|----------|
| 1. INTRODUCTION .....                      | 1-1      |
| A. BACKGROUND.....                         | 1-1      |
| B. AUTHORITY.....                          | 1-1      |
| C. OBJECTIVE .....                         | 1-1      |
| D. CONCLUSION .....                        | 1-1      |
| 2. ATTENDEES.....                          | 2-1      |
| 3. TEST EQUIPMENT.....                     | 3-1      |
| 4. TEST PROCEDURES .....                   | 4-1      |
| A. RAIL TEST .....                         | 4-1      |
| B. ON/OFF ROAD TEST .....                  | 4-3      |
| 1. HAZARD COURSE .....                     | 4-3      |
| 2. ROAD TRIP .....                         | 4-4      |
| 3. PANIC STOPS.....                        | 4-4      |
| 4. WASHBOARD COURSE .....                  | 4-4      |
| C. OCEAN GOING VESSEL TEST (STS).....      | 4-5      |
| 5. TEST RESULTS .....                      | 5-1      |
| 5.1 TESTING DATE- (17-19 Oct 2001).....    | 5-1      |
| A. RAIL TEST .....                         | 5-2      |
| B. ON/OFF ROAD TEST .....                  | 5-6      |
| 1. HAZARD COURSE.....                      | 5-6      |
| 2. ROAD TRIP.....                          | 5-7      |
| 3. PANIC STOPS.....                        | 5-7      |
| 4. WASHBOARD COURSE.....                   | 5-8      |
| C. SHIPBOARD TRANSPORTATION SIMULATOR..... | 5-9      |
| D. AIR BAG HISTORY.....                    | 5-10     |
| 5.2 TESTING DATE- (28 Jan 2002).....       | 5-13     |
| A. RAIL TEST.....                          | 5-15     |
| 6. ACCELEROMETER DATA.....                 | 6-1      |
| 7. DRAWINGS.....                           | 7-1      |

## **PART 1 – INTRODUCTION**

**A. BACKGROUND.** The U.S. Army Defense Ammunition Center (DAC), Validation Engineering Division (SOSAC-DEV), was tasked by the Air Force Air Expeditionary Battlelab to conduct transportability testing using the Cordstrap™ material to secure the MK-82 500-pound bombs in an end-opening 20-foot-long intermodal container. Loading procedures specified in AMC Drawing 19-48-8643 were used as a guideline. The container load was tested in accordance with TP-94-01, "Transportability Testing Procedures."

**B. AUTHORITY.** This test was conducted IAW mission responsibilities delegated by the U.S. Army Operations Support Command (OSC), Rock Island, IL. Reference is made to the following:

1. AR 740-1, 15 June 2001, Storage and Supply Activity Operation.
2. IOC-R, 10-23, Mission and Major Functions of USADAC, 7 January 1998.

**C. OBJECTIVE.** The objective of the testing was to validate the use of Cordstrap™ material as an alternative to wood for restraint of the MK-82 500-pound bombs in an end-opening 20-foot-long intermodal container.

**D. CONCLUSION.** Based on our review and testing the Cordstrap™ material was not effective as an alternative to wood for restraint of the MK-82 500-pound bombs in an end-opening 20-foot-long intermodal container. During testing the Cordstrap™ either stretched excessively or broke which allowed the payload to move. Also, the airbags that were used during initial testing lost pressure due to temperature changes and would not hold the load tightly. The Cordstrap™ system is dependent upon the intermodal container having lashing rings located along the floor and roof. Not all intermodal containers have lashing rings; and, therefore, the system could not be used in containers without rings. Additionally,

the Cordstrap™ material was not effective as an alternative to wood since considerable wood dunnage was still required to block and brace the payload. The Cordstrap™ material could not be used as a forward bulkhead and required excessive time and labor to install.

**PART 2 - ATTENDEES**

**ATTENDEE**

**MAILING ADDRESS**

Philip Barickman  
General Engineer  
DSN 956-8992  
(918) 420-8992

Director  
U.S. Army Defense Ammunition Center  
ATTN: SOSAC-DEV  
1 C Tree Road, Bldg. 35  
McAlester, OK 74501-9053

Darren Ward  
(425) 394-1190

Cordstrap USA Inc.  
4261 258<sup>th</sup> Avenue SE  
Issaquah, WA 98029

Harold Riphagen  
Export Director  
31 (0) 493 320005

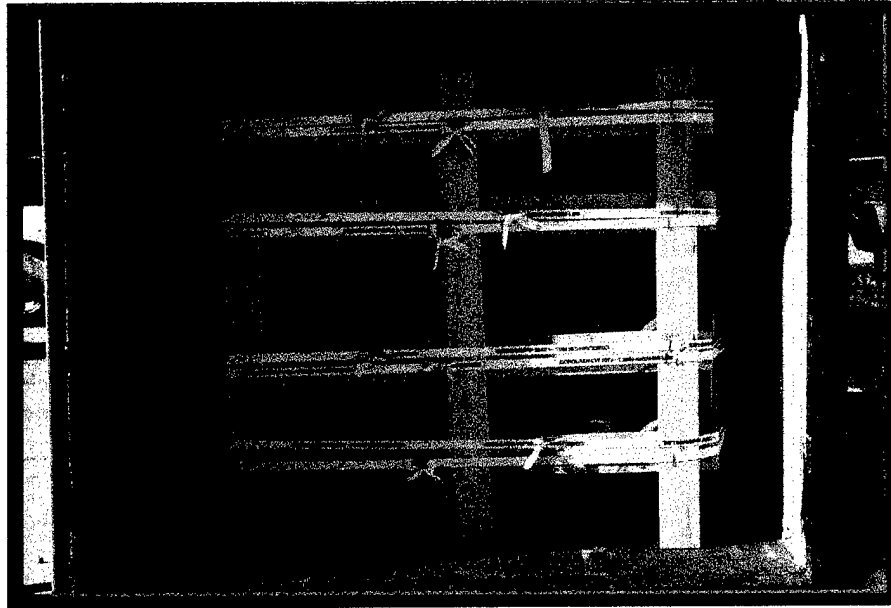
Cordstrap bv  
P.O. Box 315  
5750 AH Deurne – The Netherlands

MSgt Tim Lewis  
Munitions Director  
DSN 728-3524  
(808) 828-3524

U.S. Air Force  
Air Expeditionary Battlelab  
360 Gunfighter Ave  
Mt Home, ID 83648

### PART 3 - TEST EQUIPMENT

1. MK-82 500-pound bombs using Cordstrap™ for restraint.



**Photo No. 1: Loaded container with MK-82 bombs and Cordstrap™.**

2. Intermodal End-Opening Container, 20-foot long  
Manufactured by: Evergreen Heavy Industries Corp.  
Date of Manufacture: 11/90  
ID #: USSC 0018162  
Maximum Gross Weight: 52,910 Pounds  
Tare Weight: 4,850 Pounds  
(Used during October 2001 Testing)
3. Intermodal End-Opening Container, 20-foot long  
Manufactured by: Siam Cargo Container Ltd.  
Date of Manufacture: 12/96  
ID #: MLCU 3211090  
Maximum Gross Weight: 67,200 Pounds  
Tare Weight: 4,850 Pounds

(Used during January 2002 Testing)

4. Truck, Tractor

5-Ton, 6 X 6

Model #: M931 A2 wo/winch

Manufactured by: BMY – Division of HARSCO

ID #: 31 021 89

NSN: 2320 01 230 0302

Weight: 20,100 pounds

5. Semitrailer, Flatbed, Breakbulk/Container Transporter, 22.5 Ton

Model #: M871

Manufactured by Southwest Truck Body, St. Louis, MO

ID #: NX03PJ – 0063

NSN: 2330 00 122 6799

Weight: 15,630 pounds

## **PART 4 - TEST PROCEDURES**

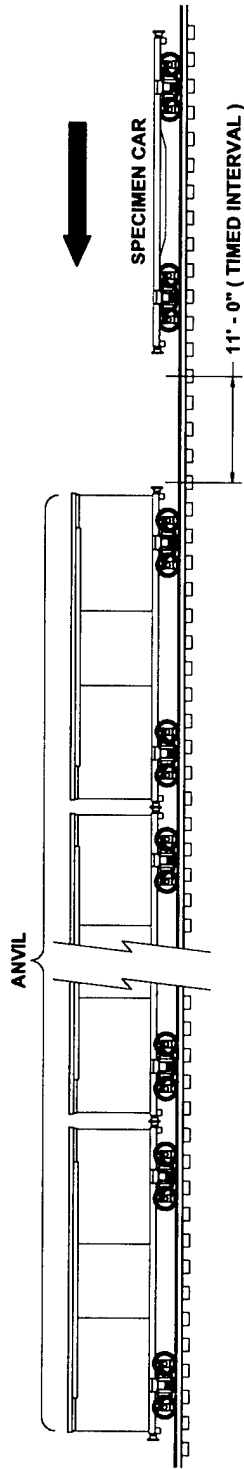
The test procedures outlined in this section were extracted from TP-94-01, "Transportability Testing Procedures," July 1994, for validating tactical vehicles and outloading procedures used for shipping munitions by truck and railcar.

Inert (non-explosive) items were used to build the load. The test loads were prepared using the blocking and bracing procedures proposed for use with munitions (**see Part 7 for procedures**). The weight and physical characteristics (weights, physical dimensions, center of gravity, etc.) of the test loads simulate live (explosive) ammunition.

**A. RAIL TEST. RAIL IMPACT TEST METHOD.** The test load or vehicle will be secured to a flatcar. The equipment needed to perform the test will include the specimen (hammer) car, four empty railroad cars connected together to serve as the anvil, and a railroad locomotive. The anvil cars will be positioned on a level section of track with air and hand brakes set and with draft gears compressed. The locomotive unit will push the specimen car toward the anvil at a predetermined speed, then disconnect from the specimen car approximately 50 yards away from the anvil cars allowing the specimen car to roll freely along the track until it strikes the anvil. This will constitute an impact. Impacting will be accomplished at speeds of 4, 6, and 8.1 mph in one direction and at a speed of 8.1 mph in the reverse direction. The speeds will have a tolerance of plus .5 mph and minus zero mph. The impact speeds will be determined by using an electronic counter to measure the time for the specimen car to traverse an 11-foot distance immediately prior to contact with the anvil cars (see Figure 1).

# ASSOCIATION OF AMERICAN RAILROADS (AAR)

## STANDARD TEST PLAN



5 BUFFER CARS (ANVIL)  
WITH DRAFT GEAR COMPRESSED  
AND AIR BRAKES IN A SET POSITION

ANVIL CAR TOTAL WT. 250,000 LBS (APPROX)

SPECIMEN CAR IS RELEASED BY  
SWITCH ENGINE TO ATTAIN:

- IMPACT NO. 1 @ 4 MPH
- IMPACT NO. 2 @ 6 MPH
- IMPACT NO. 3 @ 8.1 MPH

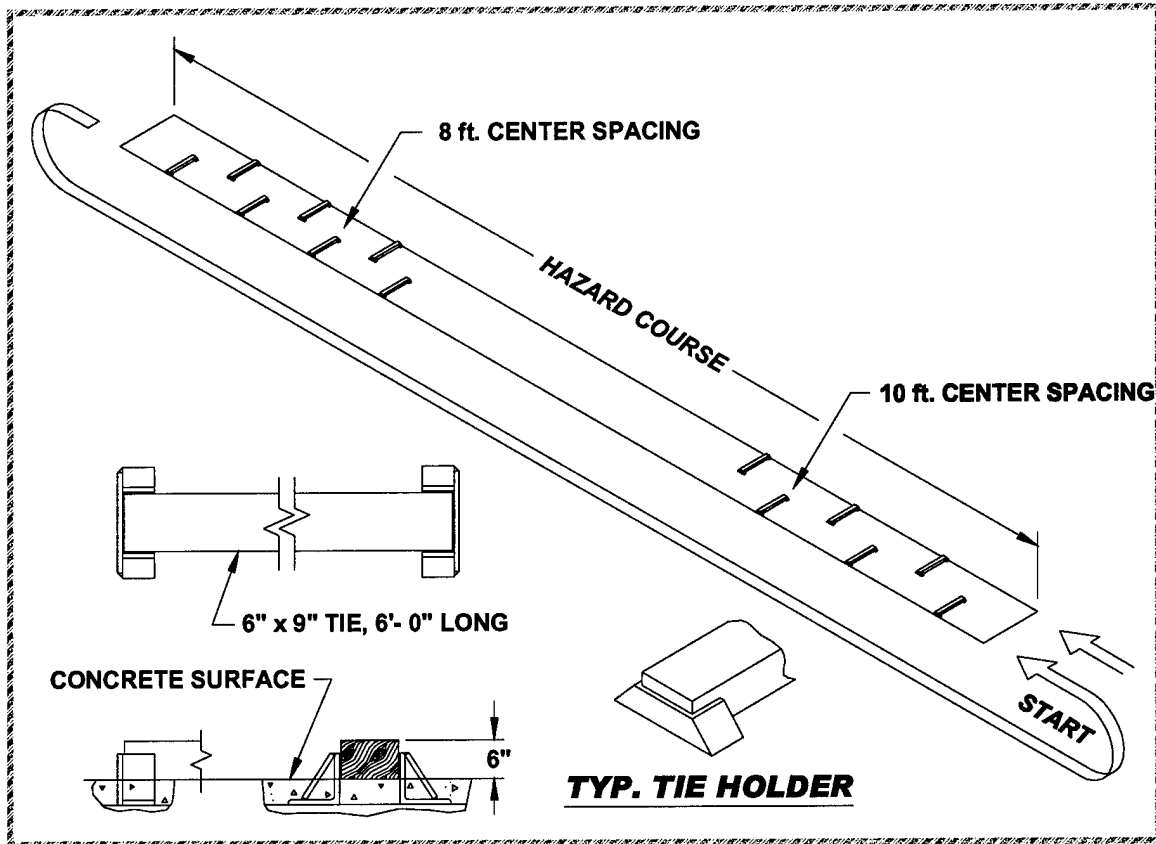
THEN THE CAR IS REVERSED AND RELEASED  
BY SWITCH ENGINE TO ATTAIN:

- IMPACT NO. 4 @ 8.1 MPH

FIGURE 1. RAIL IMPACT SKETCH

**B. ON/OFF ROAD TEST.**

1. **HAZARD COURSE.** The test load or vehicle will be transported over the 200-foot-long segment of concrete-paved road consisting of two series of railroad ties projecting 6 inches above the level of the road surface. The hazard course will be traversed two times (see Figure 2).



**Figure 2. Hazard Course Sketch**

- a. The first series of 6 ties are spaced on 10-foot centers and alternately positioned on opposite sides of the road centerline for a distance of 50 feet.
- b. Following the first series of ties, a paved roadway of 75 feet separates the first and second series of railroad ties.

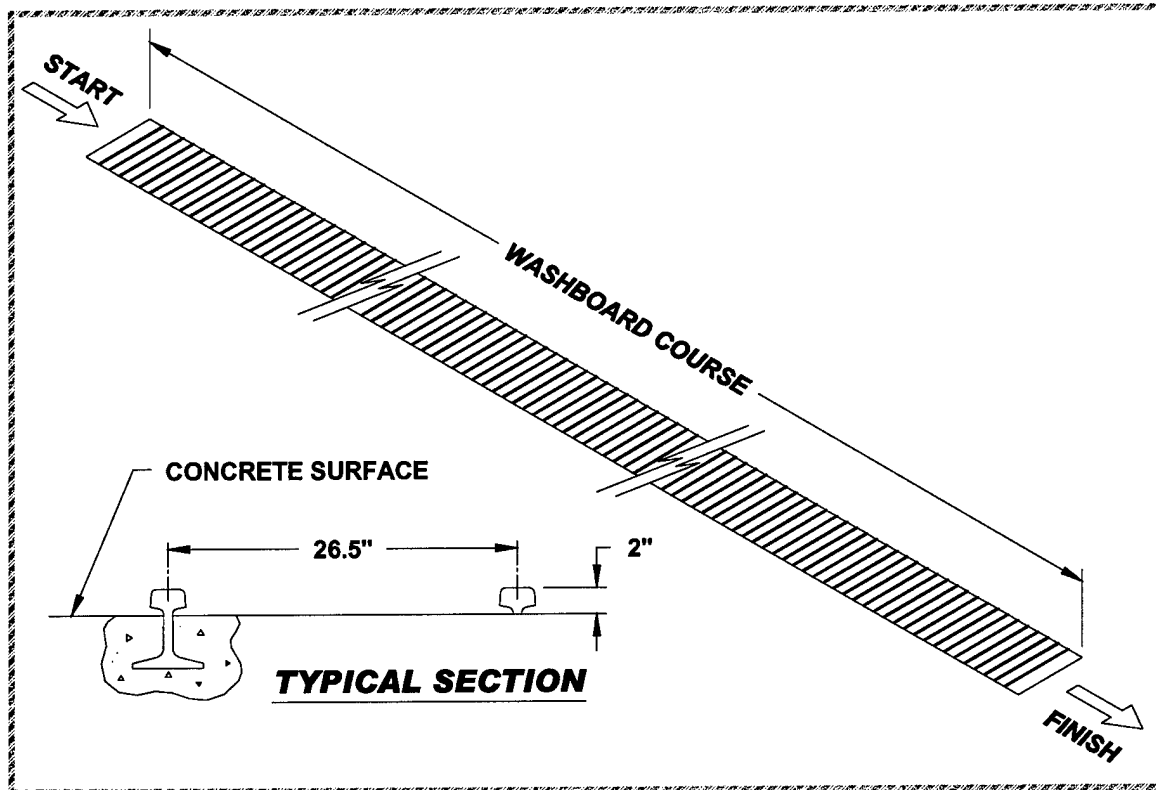
c. The second series of 7 ties are spaced on 8-foot centers and alternately positioned on opposite sides of the road centerline for a distance of 50 feet.

d. The test load is driven across the hazard course at speeds that will produce the most violent vertical and side-to-side rolling reaction obtainable in traversing the hazard course (approximately 5 mph).

2. **ROAD TRIP.** The test load or vehicle will be transported for a distance of 30 miles over a combination of roads surfaced with gravel, concrete, and asphalt. The test route will include curves, corners, railroad crossings and stops and starts. The test load or vehicle will travel at the maximum speed for the particular road being traversed, except as limited by legal restrictions.

3. **PANIC STOPS.** During the road trip, the test load or vehicle will be subjected to three (3) full airbrake stops while traveling in the forward direction and one in the reverse direction while traveling down a 7 percent grade. The first three stops are at 5, 10, and 15 mph while the stop in the reverse direction is approximately 5 mph. This testing will not be required if the Rail Impact Test is performed.

4. **WASHBOARD COURSE.** The test load or vehicle will be driven over the washboard course at a speed that produces the most violent response in the vertical direction.



**Figure 3. Washboard Course Sketch**

**C. OCEAN-GOING VESSEL TEST. SHIPBOARD TRANSPORTATION SIMULATOR (STS) TEST METHOD.** The test load will be secured inside an ISO container and will be positioned onto the STS and securely locked in place using the cam locks at each corner. Oscillation of the STS will be started and rotate to an angle of 30 degrees plus or minus 2 degrees, either side of center and at a frequency of 2 cycles-per-minute (30 seconds plus or minus 2 seconds total roll period). This frequency will be observed for apparent defects that could cause a safety hazard. The frequency of oscillation will then be increased to 4 cycles-per-minute (15 seconds plus or minus 1 second per roll period) and the apparatus operated a period of two (2) hours. An inspection of the load will then be conducted. If the inspection does not indicate an impending failure, the frequency of oscillation will be further increased to 5 cycles-per-minute (12 seconds plus or minus 1 second-cycle time), and the apparatus operated for four (4) hours. The operation does not necessarily have to be continuous, however, no change or adjustments to the load or load restraints will be permitted at any

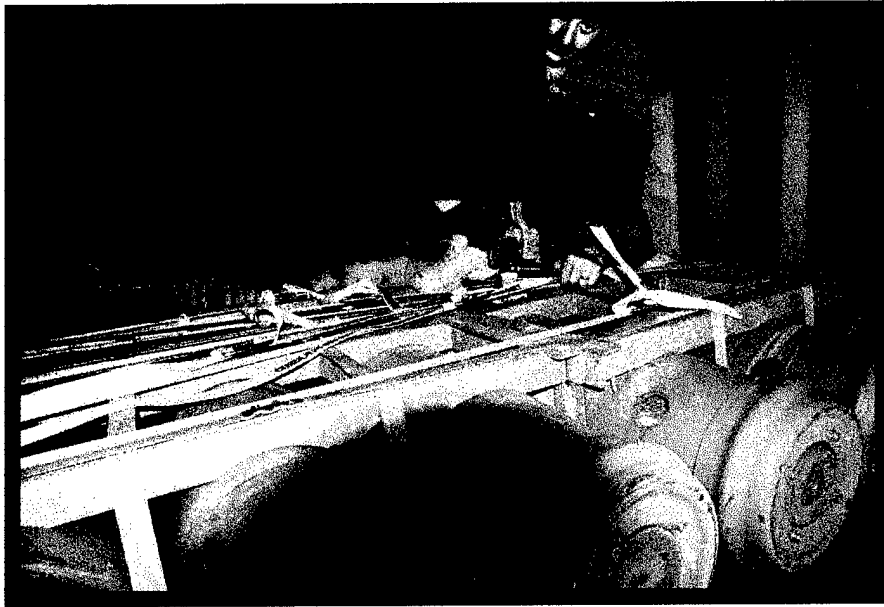
time during the test. After once being set in place, the test load (specimen) will not be removed from the apparatus until the test has been completed or is terminated

## **PART 5 - TEST RESULTS**

**5.1 Testing Date: 17-19 October 2001**

**Payload: Cordstrap™ Material with MK-82 Payload**

**Gross Weight: 40,850 pounds**

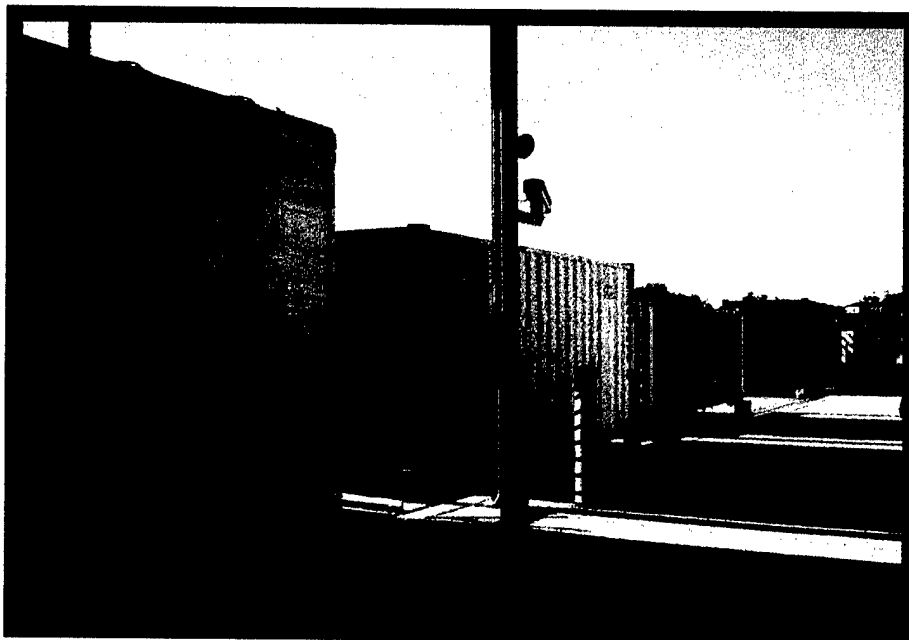


**Photo 2: Tightening of Cordstrap™ prior to testing.**



**Photo 3: Fully loaded container with Cordstrap™, airbags and MK-82 bombs prior to testing.**

**A. RAIL TEST. RAIL IMPACT TEST METHOD.**



**Photo 4: Rail Impact testing of Cordstrap™.**

| Description  | Weight       |
|--|--------------|
| Flatcar Number:<br>DODX 48797                      | 62,700 lbs.  |
| Intermodal Container with<br>2,000 # GBU-31(V) 1/B | 36,225 lbs.  |
| M1 Flatrack with MLRS Pods                         | 28,265 lbs.  |
| Intermodal container with<br>Cordstrap™ Restraint  | 40,850 lbs.  |
| Total Specimen Wt.                                 | 168,040 lbs. |
| Buffer Car (four cars)                             | 250,000 lbs. |

**Figure 4**

**Remarks:** Figure 4 lists the test components and weights of the items used during the Rail Impact Tests. The intermodal container with the Cordstrap™ and MK-82 bombs was secured on the Container-on-Flatcar (COFC). The M1 Flatrack with MLRS pods and the intermodal container with the 2000-pound bombs were used as ballast for the test.

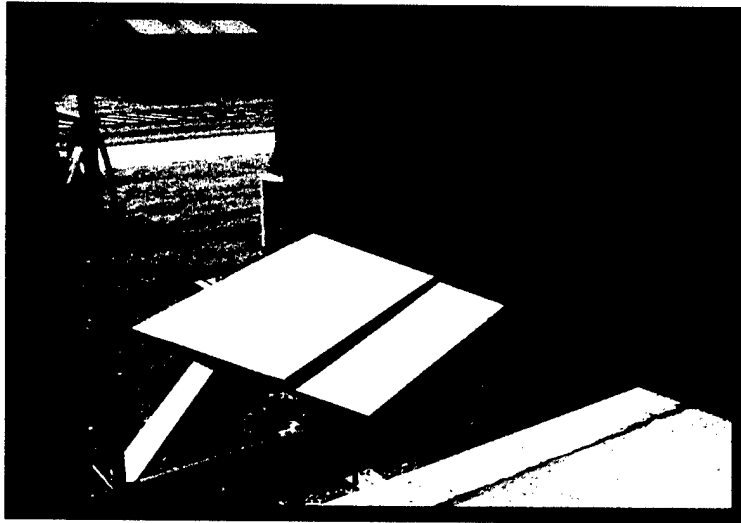
| Impact Number | Velocity (mph) |
|---------------|----------------|
| 1             | 4.1            |
| 2             | 6.2            |
| 3             | 8.4            |
| 4             | Not Conducted  |

**Figure 5**

**Remarks:**

1. Figure 5 lists the average speeds of the specimen car immediately prior to impact with the anvil. Impact # 4 would have been the reverse impact.
2. Following Impact # 2 the load moved 0.5 inches toward the container door. The payload at the closed end of the container was no longer in contact with the end gate.

3. Following Impact # 3 the load moved 6-8 inches toward the container door. The vertical strap broke at the top-lashing ring, curbside of the container. This allowed the entire end wall and strapping to loosen and the load to move.
4. Due to the catastrophic failure of the strapping, testing was stopped following Impact # 3 and the container was offloaded from the railcar.



**Photo 5: Final dunnage position following 8 mph rail impact and straps breaking.**



**Photo 6: Broken straps following 8 mph rail impact.**



**Photo 7: Shifted payload following 8 mph rail impact.**

In order to gain additional information the Cordstrap™ representatives were permitted to reload the container using different strapping and the Hazard Course, Road Trip, Washboard Course, and Shipboard Transportation Simulator (STS) tests were conducted. The follow-on testing was for informational purposes only.

**B. ON/OFF ROAD TESTS.**

**1. HAZARD COURSE.**



**Photo 8: Hazard Course testing of Cordstrap™ and MK-82 bombs.**

| <b>Pass No.</b> | <b>Elapsed Time</b> | <b>Velocity (mph)</b> |
|-----------------|---------------------|-----------------------|
| <b>1</b>        | <b>24 Seconds</b>   | <b>6.1</b>            |
| <b>2</b>        | <b>26 Seconds</b>   | <b>5.6</b>            |
| <b>3</b>        | <b>27 Seconds</b>   | <b>5.4</b>            |
| <b>4</b>        | <b>24 Seconds</b>   | <b>6.1</b>            |

**Figure 6**

**Remarks:**

1. Figure 6 lists the average speeds of the test load through the Hazard Course.
2. Following Passes #2 and #4 the load was examined and no significant movement or damage to the system was found.
3. Passes #3 and #4 were conducted following the completion of the Road Trip.

2. **ROAD TRIP.** Examination of the load and strapping system upon completion of the road trip revealed that the straps across the nose end of the bombs, at the closed end of the container, had loosened. The loosening was caused by the straps sliding toward the nose end of the bombs.



**Photo 9: Loose Cordstrap™ following Road Course.**

3. **PANIC STOPS.** Testing was not performed since earlier load had already demonstrated poor longitudinal restraint of Cordstrap™ material during rail impact test.

#### **4. WASHBOARD COURSE.**



**Photo 10: Washboard Course testing of Cordstrap™ with MK-82 bombs.**

#### **Remarks:**

1. The straps across the nose ends of the bombs at the closed end of the container slipped completely off of the bombs.
2. The load moved 0.5 inches toward the driver's side of the container and 0.125 inches toward the closed end of the container.

**C. OCEAN-GOING VESSEL. SHIPBOARD TRANSPORTATION SIMULATOR (STS) TEST METHOD.**

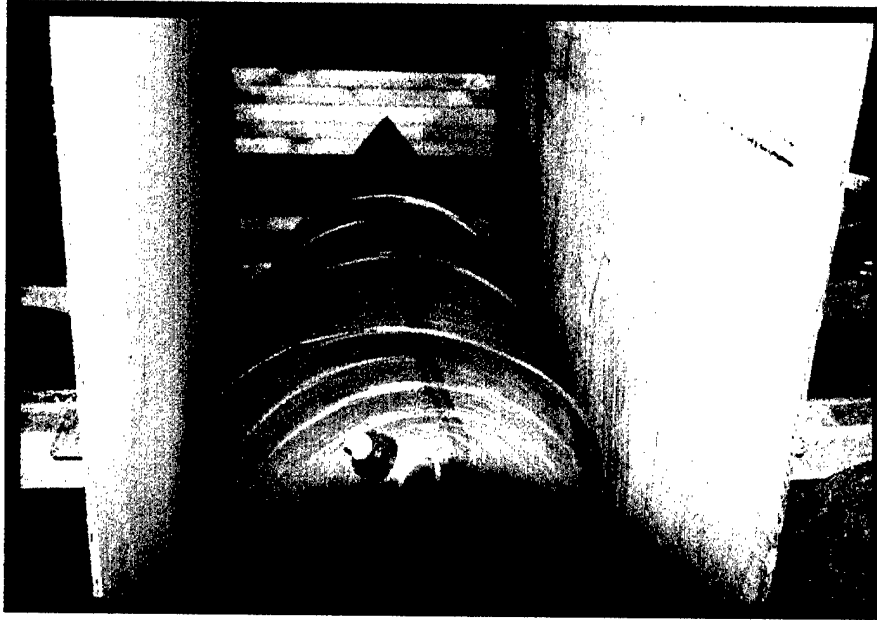


**Photo 11: Shipboard Transportation Simulator testing of Cordstrap™ with MK-82 bombs.**

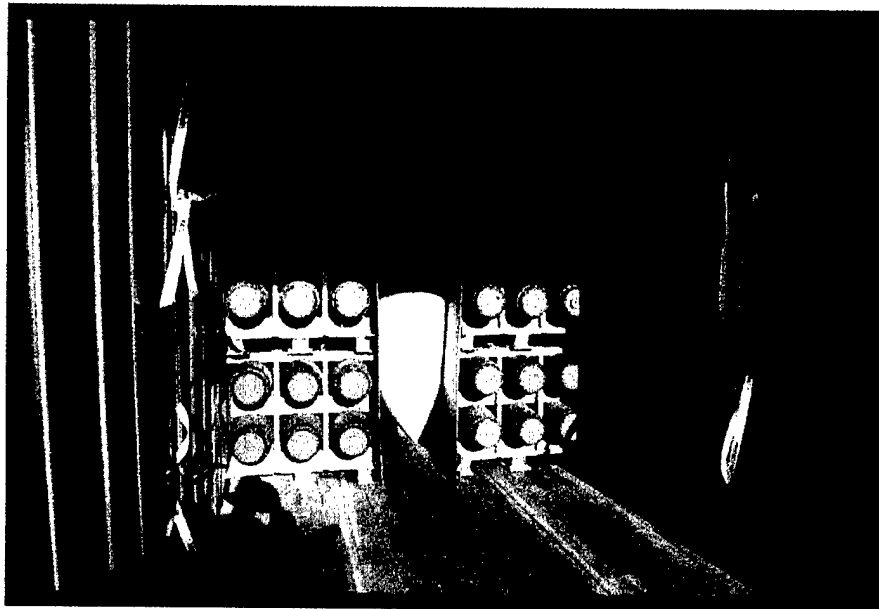
**Remarks:**

1. The intermodal container with the Cordstrap™ and MK-82 bombs were removed from the trailer and positioned onto the STS.
2. During testing the load moved 1 inch in each direction (left and right). The total movement was 2 inches.
3. The center pallet, on the driver's side, shifted during testing. The pallet shifted away from the container wall 0.25 inches at the base of the bomb to 1 inch at the nose end of the bomb.
4. The anti-slip pads between the pallets and the container floor, at the door end of the container, wore through.

**D. AIR BAG HISTORY.** Air bags were used in blocking and bracing the MK-82 bomb pallets in the intermodal container. One air bag was located in the front (closed end) of the container and one was located in the center.



**Photo 12: View of front air bag.**



**Photo 13: View of center air bag.**

During the complete testing sequence, the pressure in each air bag was monitored. The pressures were as follows:

1 bar = 14.5 pounds/inch<sup>2</sup>

16 October 2001, 1300 HRS

Front – 0.225 bar

Center – 0.225 bar

17 October 2001, 0845 HRS

Front – 0.200 bar

Center – 0.215 bar

17 October 2001, 1100 HRS

Front – 0.210 bar

Center – 0.220 bar

Following the 1100 hrs reading the bags were removed from the container and deflated and destroyed. The container was then reloaded using different straps and new air bags.

17 October 2001, 1400 HRS

Front – 0.250 bar

Center – 0.25 bar

18 October 2001 – 0730 HRS

Front – 0.190 bar

Center – 0.210 bar

18 October 2001 – 1330 HRS

Front – 0.200 bar

Center – 0.250 bar

21 November 2001 – 0900 HRS

Front – 0.125 bar

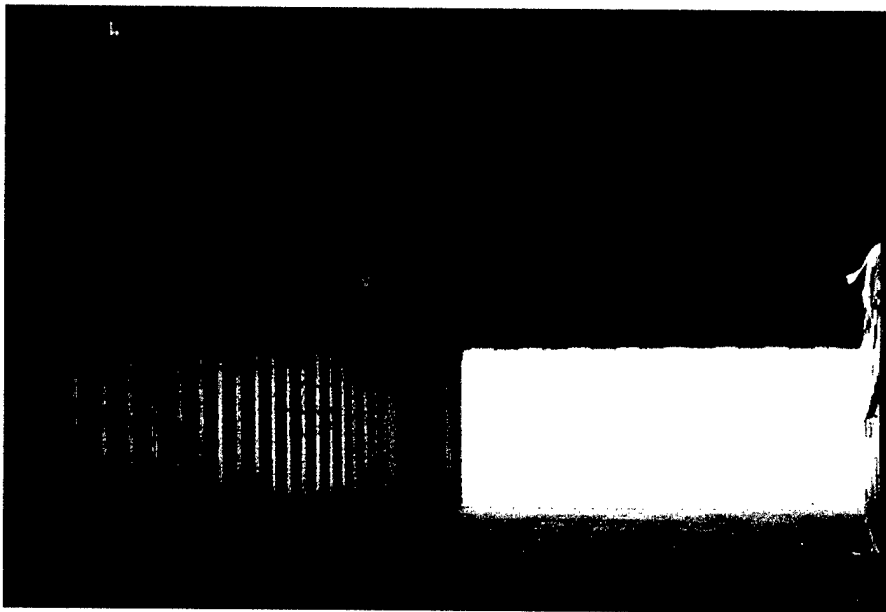
Center – 0.100 bar

**Remarks:** Air bags are not an acceptable alternative for wood blocking and bracing. The air bags deflated over time due to changes in temperature and pressure and would not hold the load tight. Also, air bags are susceptible to puncture and damage.

**5.2 Testing Date:** 28 January 2002

Payload: Cordstrap™ Material with MK-82 Payload

Gross Weight: 40,850 pounds

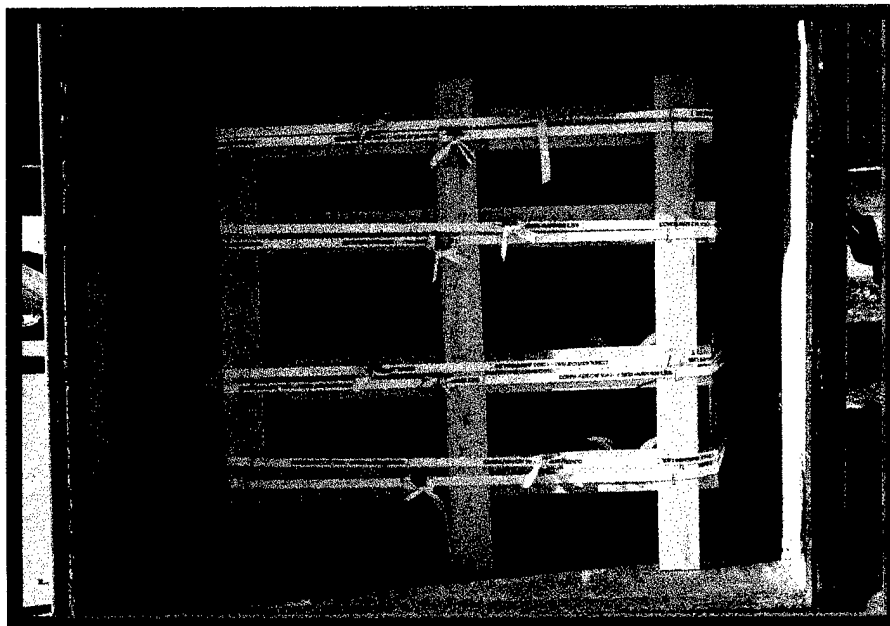


**Photo 14: Pre-Staging of Cordstrap™ prior to loading container with MK-82 bombs.**

**Note:** The customer, USAF Air Force Air Expeditionary Battlelab, only required that Rail Testing be conducted; therefore, Hazard Course, Road Trip, Washboard Course, and Shipboard Transportation Simulator tests were not conducted.



**Photo 15: Cordstrap™ restraining payload.**



**Photo 16: Fully loaded container with Cordstrap™ and MK-82 bombs.**

**A. RAIL TEST. RAIL IMPACT TEST METHOD.**

| Description                                       | Weight       |
|---|--------------|
| Flatcar Number:<br>DODX 48797                     | 62,700 lbs.  |
| M1 Flatrack with MLRS Pods                        | 28,265 lbs.  |
| Intermodal container with<br>Cordstrap™ Restraint | 40,850 lbs.  |
| Total Specimen Wt.                                | 131,815 lbs. |
| Buffer Car (four cars)                            | 250,000 lbs. |

**Figure 7**

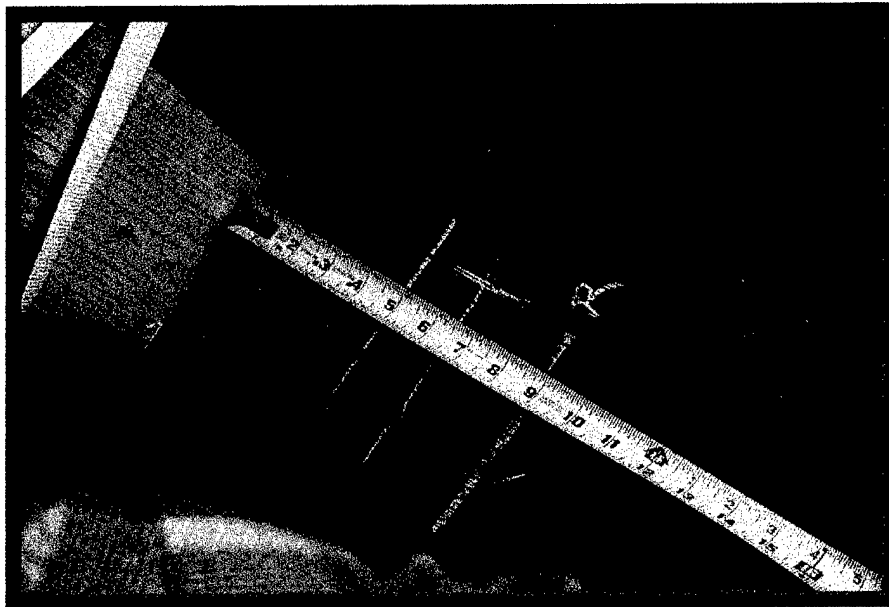
**Remarks:** Figure 7 lists the test components and weights of the items used during the Rail Tests. The intermodal container with the Cordstrap™ and MK-82 Bombs was secured on the Container-on-Flatcar (COFC). The M1 Flatrack with MLRS pods was used as ballast for the test.

| Impact Number | Velocity (mph) |
|---------------|----------------|
| 1             | 4.4            |
| 2             | 6.6            |
| 3             | 8.1            |
| 4             | 8.2            |

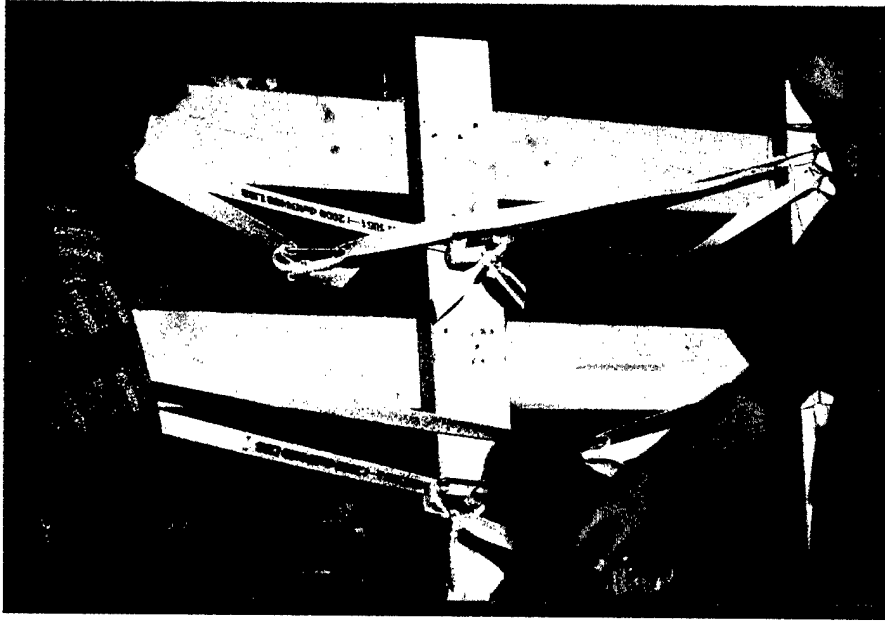
**Figure 8**

**Remarks:**

1. Figure 8 lists the average speeds of the specimen car immediately prior to impact with the anvil. Impact # 4 is the reverse impact.
2. Following Impact # 2 the payload moved 0.75 inches.
3. Following Impact # 3 the payload moved an additional 1- 1.5 inches.
4. Following Impact # 4 the payload moved 8.5 – 9 inches.
5. The movement of the payload was excessive and could result in damage to the intermodal container and/or the payload. The testing was discontinued due to the unsafe condition.



**Photo 17: Movement of payload from 8 mph reverse rail impact.**



**Photo 18: Loose straps following reverse 8 mph impact.**

## **PART 6 – ACCELEROMETER DATA**

The first accelerometers were located in various areas on the test specimen. These areas are described on each of the following graphic depictions of each of the railcar impacts, hazard course, road course, and washboard course. The axial orientation of the accelerometers is as follows:

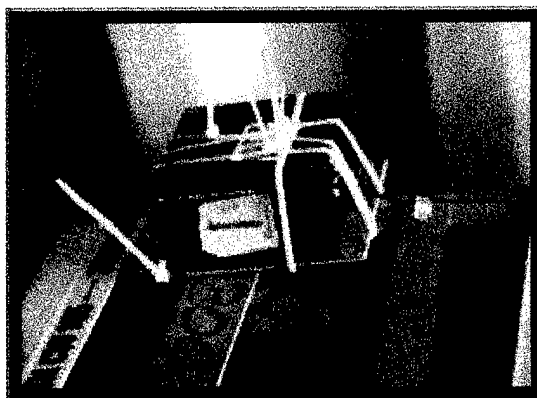
r – resultant vector    x – longitudinal axis    y – lateral axis    z – vertical axis

A table depicting the identification and location of the graphic illustrations is below:

| <b>M871A3</b>      |             |                        |
|--------------------|-------------|------------------------|
| <b>TEST</b>        | <b>PAGE</b> | <b>SENSOR LOCATION</b> |
| <b>Rail Impact</b> | <b>6-2</b>  | <b>Railcar Coupler</b> |
| <b>Rail Impact</b> | <b>6-3</b>  | <b>Container Rear</b>  |
| <b>Rail Impact</b> | <b>6-4</b>  | <b>Container Front</b> |

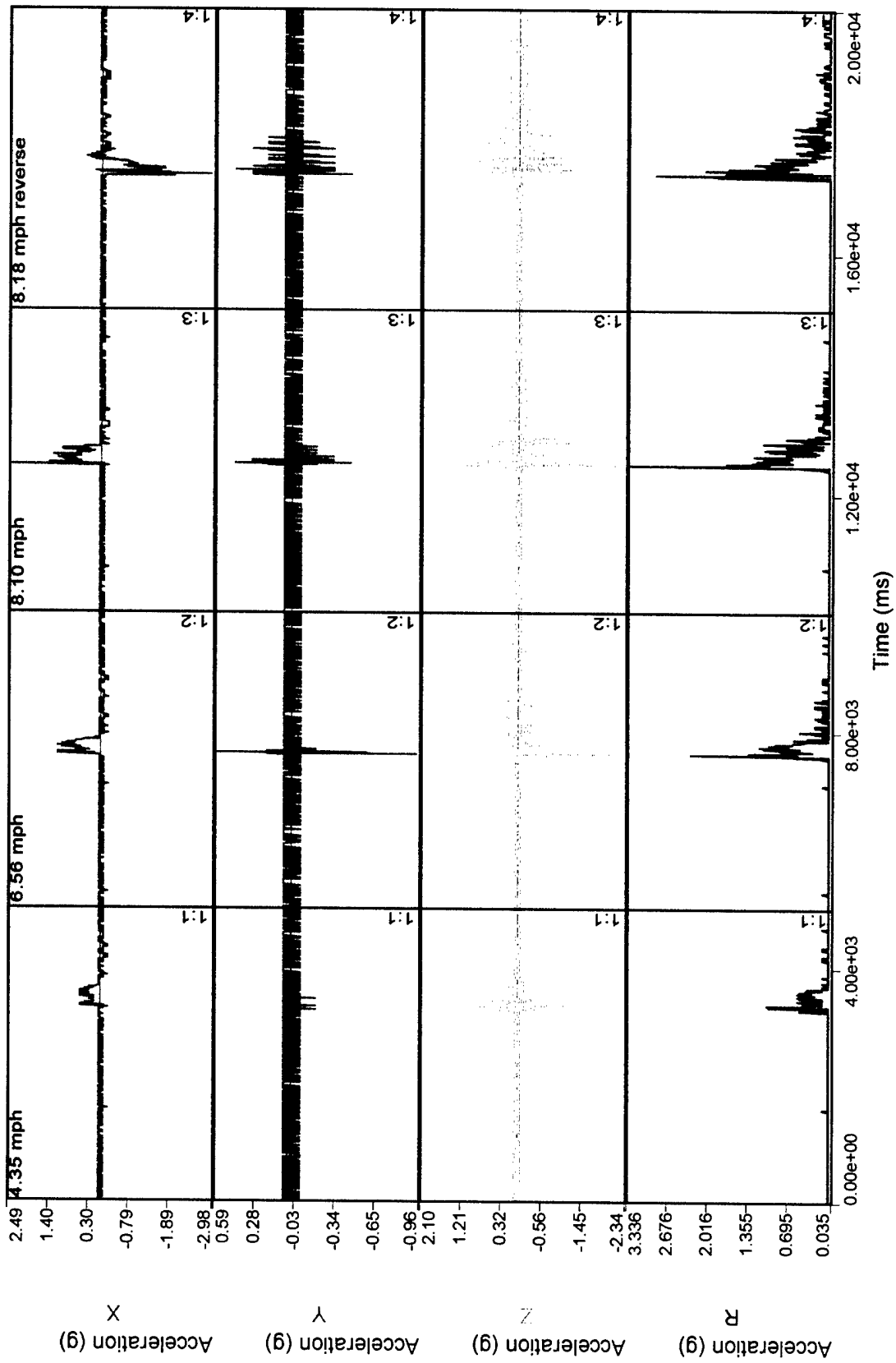


**Photo 19: Sensor located at container front on MK-82 pallets**

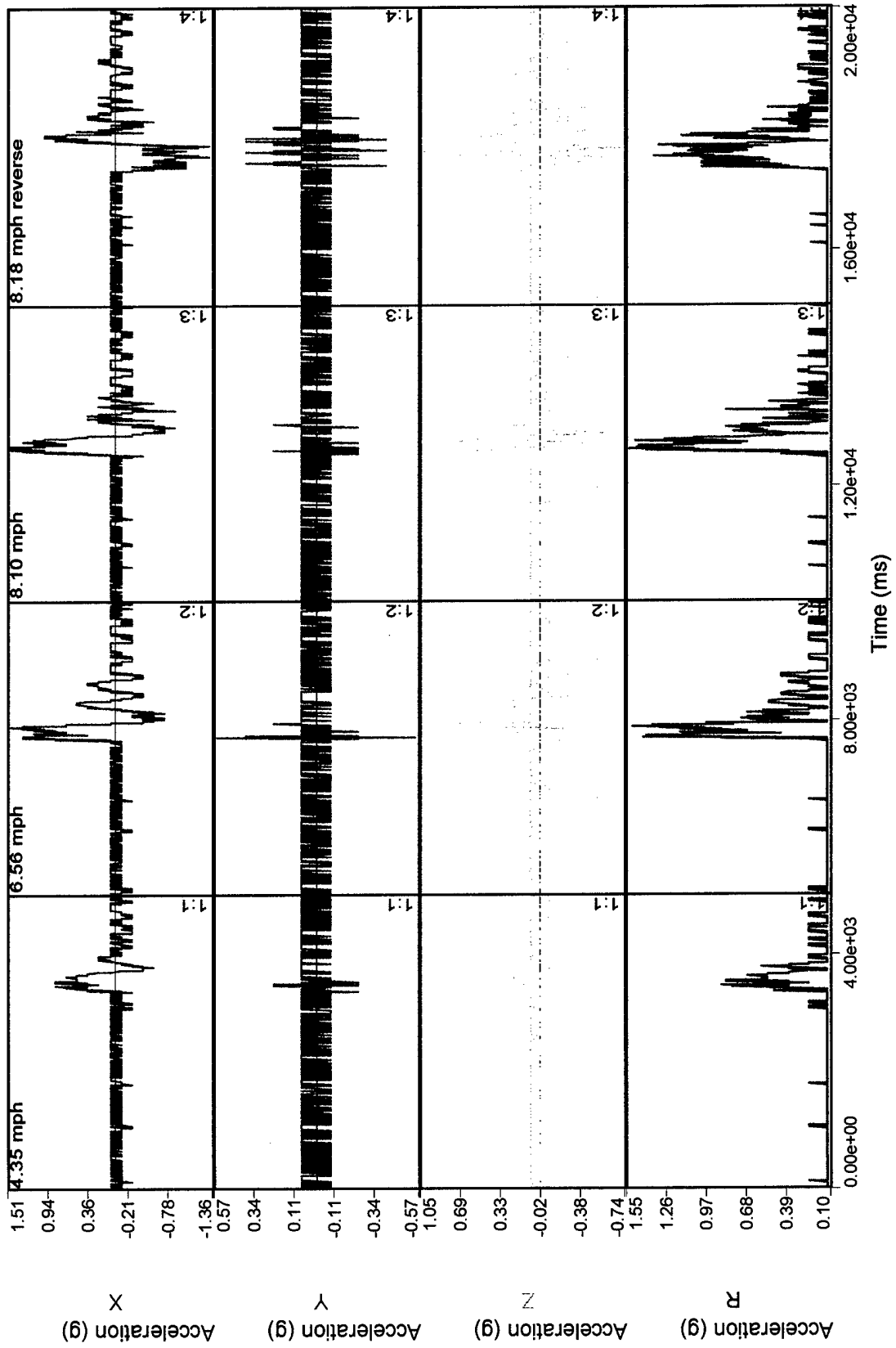


**Photo 19: Sensor located at container rear on MK-82 pallets.**

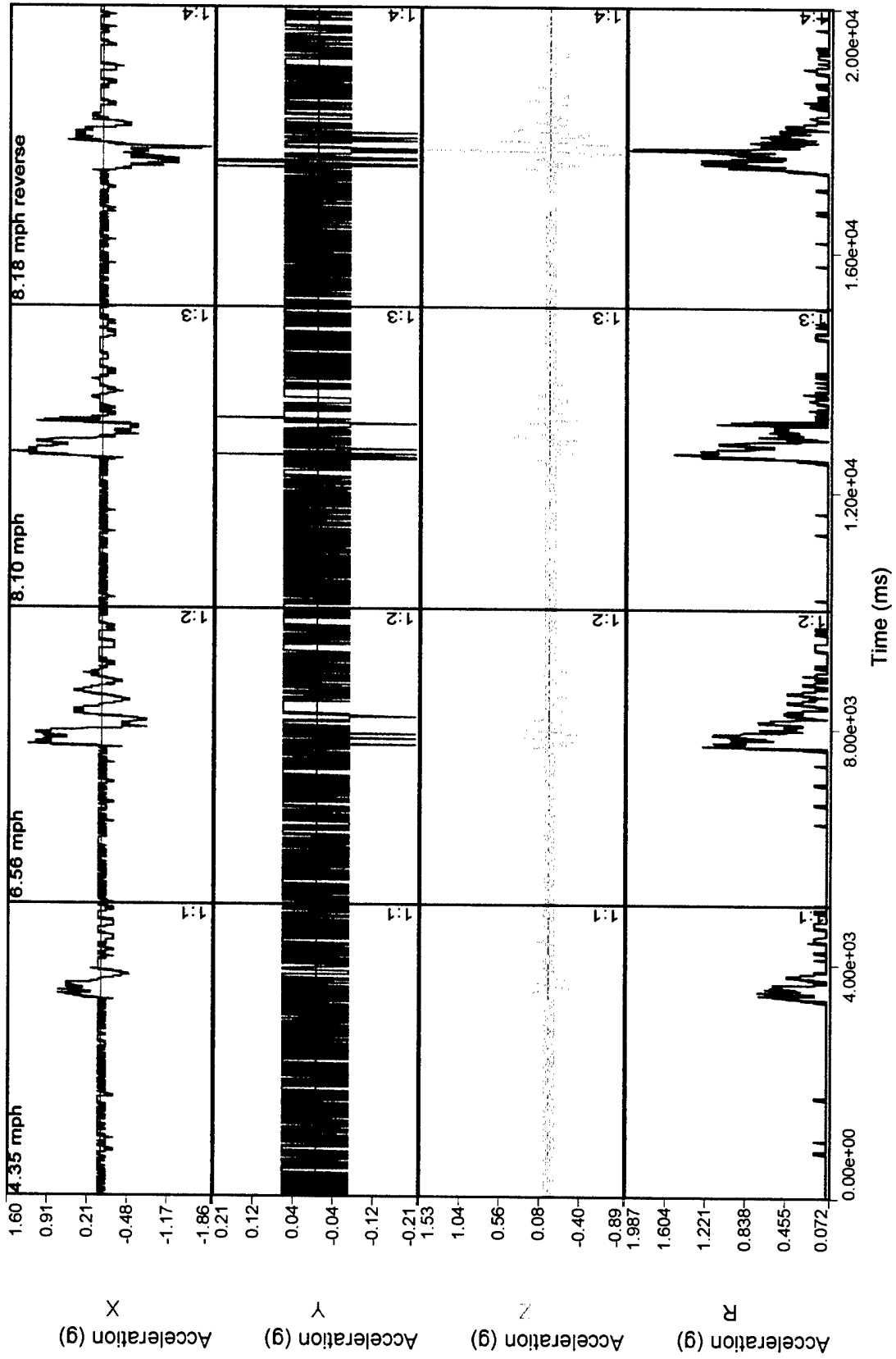
Wave View: Rail Impact #0178 on rail car coupler. 28 January 2002



Multiple Wave View: Rail Impact #0185 at container rear (see Photo 20). 28 January 2002



Multiple Wave View: Rail Impact #0186 at container front (see Photo 19). 28 January 2002



## **PART 7 – DRAWINGS**

The following drawing represents the load configuration that was subjected to the test criteria. The drawing can be accessed at:

**<http://www.dac.army.mil/DET/dapam/toc.html>**

APPROVED BY  
BUREAU OF EXPLOSIVES

*D. M. Hoy*

DATE 3-18-97

# LOADING AND BRACING\* IN END OPENING ISO CONTAINERS OF MK82 (500 POUND) BOMBS ON MHU-149/E METAL PALLETS

## INDEX

| ITEM  | PAGE(S) |
|---|---------|
| TYPICAL LOADING PROCEDURES - - - - -                | 2       |
| GENERAL NOTES AND MATERIAL SPECIFICATIONS - - - - - | 3       |
| PALLET UNIT DETAIL - - - - -                        | 4       |
| DETAILS - - - - -                                   | 4-8     |
| LESS-THAN-FULL-LOAD DETAILS - - - - -               | 9-10    |

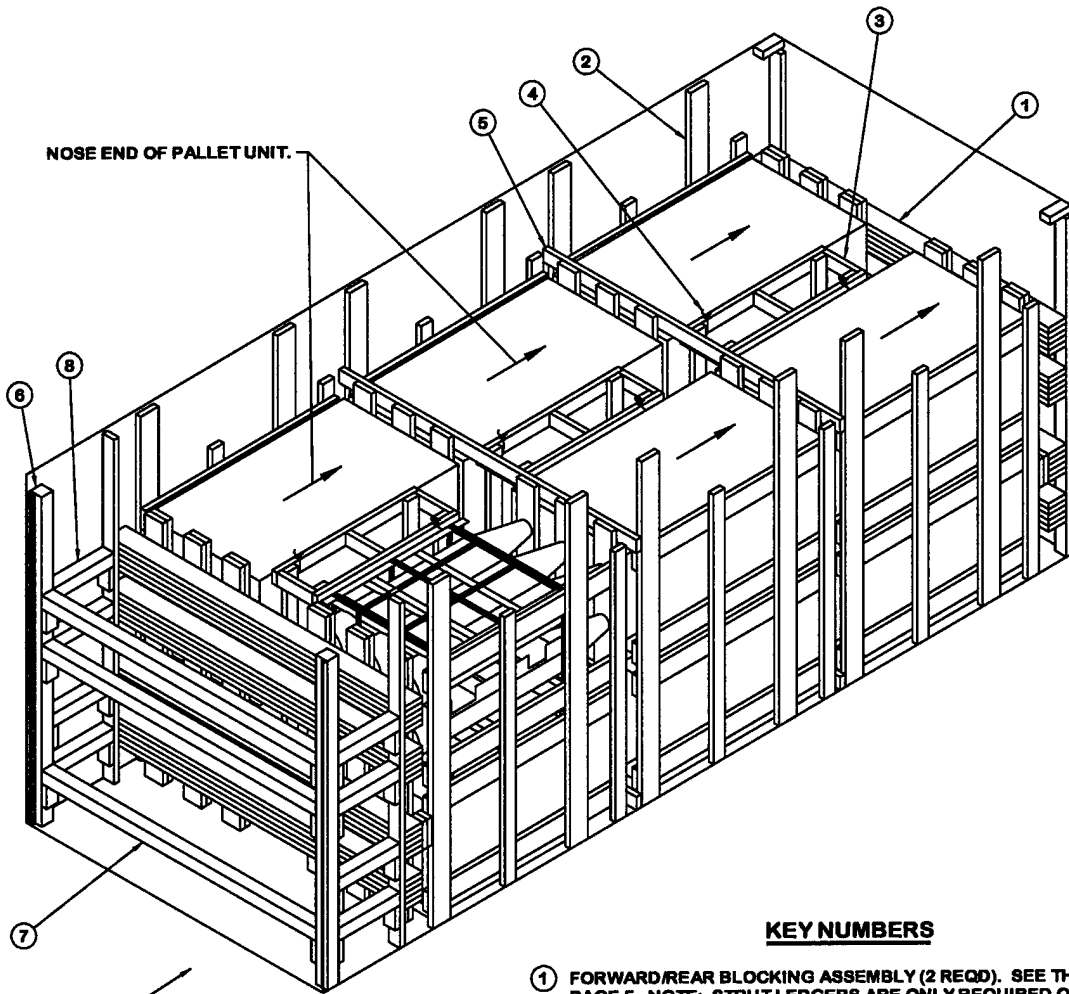
\* LOADING AND BRACING SPECIFICATIONS SET FORTH WITHIN THIS DRAWING ARE APPLICABLE TO LOADS THAT ARE TO BE SHIPPED BY TRAILER/CONTAINER-ON-FLATCAR (TCOFC) RAIL CARRIER SERVICE. THESE SPECIFICATIONS MAY ALSO BE USED FOR LOADS THAT ARE TO BE MOVED BY MOTOR OR WATER CARRIERS.

## U.S. ARMY MATERIEL COMMAND DRAWING

|   |   |       |                               |  |          |         |          |
|---|---|-------|-------------------------------|--|----------|---------|----------|
| APPROVED, U.S. ARMY<br>INDUSTRIAL OPERATIONS COMMAND<br><br><i>Timothy R. Fore</i>  | ENGINEER                                  | BASIC | LAURA FIEFFER                 | DO NOT SCALE   |          |         |          |
|   |   | REV.  |                               | WEBSITE: <a href="http://www.dac.army.mil">HTTP://WWW.DAC.ARMY.MIL</a> |          |         |          |
|   | TECHNICIAN                                | BASIC |                               | APRIL 1997   |          |         |          |
|   |   | REV.  |                               |  |          |         |          |
|   | DRAFTSMAN                                 | BASIC |                               |  |          |         |          |
|   |   | REV.  |                               |  |          |         |          |
| APPROVED BY ORDER OF COMMANDING GENERAL,<br>U.S. ARMY MATERIEL COMMAND<br><br><i>William J Ernst</i><br>DEFENSE AMMUNITION CENTER | TRANSPORTATION<br>ENGINEERING<br>DIVISION |       | <i>William R. Zwick</i>       |  |          |         |          |
|   | VALIDATION<br>ENGINEERING<br>DIVISION     |       | <i>Joseph H. Keefe</i> TESTED | CLASS  | DIVISION | DRAWING | FILE     |
|   | LOGISTICS<br>ENGINEERING<br>OFFICE        |       | <i>William J Ernst</i>        | 19   | 48       | 8643    | SP15PB12 |

PROJECT SP 342-97

NOSE END OF PALLET UNIT.



REAR OF CONTAINER.

**ISOMETRIC VIEW**

**KEY NUMBERS**

- ① FORWARD/REAR BLOCKING ASSEMBLY (2 REQD). SEE THE DETAIL ON PAGE 5. NOTE: STRUT LEDGERS ARE ONLY REQUIRED ON THE REAR BLOCKING ASSEMBLY. DO NOT INSTALL STRUT LEDGERS ON THE FORWARD BLOCKING ASSEMBLY.
- ② SIDE FILL ASSEMBLY (6 REQD). SEE THE DETAIL ON PAGE 6.
- ③ CENTER FILL ASSEMBLY (3 REQD). SEE THE DETAIL ON PAGE 6.
- ④ TIE WIRE, NO. 14 GAGE WIRE 24" LONG (8 REQD, 2 PER CENTER FILL ASSEMBLY). INSTALL THE WIRE TO FORM A COMPLETE LOOP AROUND THE LONGITUDINAL PIECE OF THE CENTER FILL ASSEMBLY AND THE UNITING STRAPS OF THE LADING UNIT.
- ⑤ SEPARATOR GATE (2 REQD). SEE THE DETAIL ON PAGE 5.
- ⑥ DOOR POST VERTICAL (2 REQD). SEE THE DETAIL ON PAGE 4, AND "DETAIL A" AND "DETAIL B" ON PAGE 7.
- ⑦ DOOR SPANNER, 4" X 4" MATERIAL, CUT TO A LENGTH THAT WILL PROVIDE FOR A DRIVE FIT (REF: 7'-1-3/8") (3 REQD). TOENAIL TO THE DOOR POST VERTICAL W/2-12d NAILS AT EACH END. SEE THE "BEVEL-CUT" DETAIL ON PAGE 4.
- ⑧ STRUT, 4" X 4" BY CUT-TO-FIT (REF: 19") (8 REQD). TOENAIL TO THE BUFFER PIECE OF THE REAR BLOCKING ASSEMBLY AND THE DOOR POST VERTICAL W/2-12d NAILS AT EACH END. SEE THE "BEVEL-CUT" DETAIL ON PAGE 4.

| BILL OF MATERIAL  |             |            |
|-------------------|-------------|------------|
| LUMBER            | LINEAR FEET | BOARD FEET |
| 2" X 4"           | 338         | 226        |
| 2" X 6"           | 729         | 729        |
| 4" X 4"           | 49          | 66         |
| NAILS             | NO. REQD    | POUNDS     |
| 10d (3")          | 1284        | 20         |
| 12d (3-1/4")      | 44          | 3/4        |
| WIRE, NO. 14 GAGE | 12' REQD    | NIL        |

**LOAD AS SHOWN**

| ITEM        | QUANTITY | WEIGHT (APPROX) |
|-------------|----------|-----------------|
| PALLET UNIT | 12       | 36,420 LBS      |
| DUNNAGE     |          | 2,063 LBS       |
| CONTAINER   |          | 4,700 LBS       |

TOTAL WEIGHT ----- 43,183 LBS (APPROX)

(GENERAL NOTES CONTINUED)

H. WHETHER A CONTAINER IS FULL OR IS LOADED WITH A REDUCED QUANTITY OF LADING UNITS, THE LENGTHWISE CENTER OF GRAVITY OF THE LOAD MUST BE WITHIN 12", IN EITHER DIRECTION, OF THE MID-POINT OF THE CONTAINER.

J. **CAUTION:** DO NOT NAIL DUNNAGE MATERIAL TO THE CONTAINER WALLS OR FLOOR. ALL NAILING WILL BE WITHIN THE DUNNAGE.

K. PORTIONS OF THE CONTAINER DEPICTED WITHIN THIS DRAWING, SUCH AS THE SIDEWALL, HAVE NOT BEEN SHOWN IN THE LOAD VIEWS FOR CLARITY PURPOSES.

L. MAXIMUM LOAD WEIGHT CRITERIA:

THE MAXIMUM LOAD WEIGHTS ARE CONTROLLED BY EQUIPMENT CAPABILITY FACTORS. ALTHOUGH THE HEAVIEST MAXIMUM LOADS ARE DELINEATED IN THE LOAD VIEWS, PROVISIONS ARE INCLUDED WITHIN THIS DRAWING SO THAT THE BASIC LOADS CAN BE ADJUSTED TO SATISFY A LESSER QUANTITY OF LADING UNITS. DEPENDING ON TRANSPORTATION ROUTING, IT MAY BE NECESSARY TO REDUCE THE LOAD WEIGHT TO SATISFY "WEIGHT LAWS" OF CERTAIN STATES. ALSO, IT MAY BE NECESSARY TO REDUCE THE LOAD WEIGHT TO SATISFY OTHER WEIGHT RESTRICTIONS IMPOSED ON THE INTERMODAL CONTAINER SYSTEM.

M. REQUIREMENTS CITED WITHIN THE BUREAU OF EXPLOSIVES PAMPHLET 6C APPLY WHEN THE SHIPMENT MOVES BY TRAILER/CONTAINER-ON-FLATCAR (T/COFC). SPECIAL T/COFC NOTES FOLLOW:

1. A LOADED CONTAINER MUST BE ON A CHASSIS EQUIPPED WITH TWO BOGIE ASSEMBLIES WHEN BEING MOVED IN TOFC SERVICE.
2. THE LOAD LIMIT OF A T/COFC RAILCAR MUST NOT BE EXCEEDED, NOR WILL A CAR BE LOADED SO THAT THE TRUCK UNDER ONE END OF THE CAR CARRIES MORE THAN ONE-HALF OF THE LOAD LIMIT FOR THAT CAR.

N. DURING INTRASTATE AND/OR INTERSTATE MOVES BY MOTOR CARRIER, A PROPER CHASSIS OR MODIFIED FLATBED TRAILER MUST BE USED TO PRECLUDE VIOLATION OF ONE OR MORE "WEIGHT LAWS" APPLICABLE TO THE STATE OR STATES INVOLVED.

O. CONVERSION TO METRIC EQUIVALENTS: DIMENSIONS WITHIN THIS DOCUMENT ARE EXPRESSED IN INCHES AND WEIGHTS ARE EXPRESSED IN POUNDS. WHEN NECESSARY, THE METRIC EQUIVALENTS MAY BE COMPUTED ON THE BASIS OF ONE INCH EQUALS 25.4MM AND ONE POUND EQUALS 0.454 KG.

P. THE QUANTITY OF PALLET UNITS SHOWN IN THE LOAD ON PAGE 2 MAY BE REDUCED FOR SHIPMENT, IF DESIRED. SEE THE "LESS-THAN-FULL-LOAD" DETAILS ON PAGE 9.

Q. RECOMMENDED SEQUENTIAL LOADING PROCEDURES:

1. PREFABRICATE TWO FORWARD/REAR BLOCKING ASSEMBLIES, SIX SIDE FILL ASSEMBLIES (THREE LEFT HAND AND THREE RIGHT HAND), THREE CENTER FILL ASSEMBLIES, TWO SEPARATOR GATES AND TWO DOOR POST VERTICALS (ONE LEFT HAND AND ONE RIGHT HAND).
2. INSTALL THE FORWARD BLOCKING ASSEMBLY.
3. INSTALL TWO SIDE FILL ASSEMBLIES (ONE LEFT HAND AND ONE RIGHT HAND).
4. LOAD FOUR PALLET UNITS.
5. INSTALL ONE CENTER FILL ASSEMBLY WITH TIE WIRE.
6. INSTALL ONE SEPARATOR GATE.
7. REPEAT STEPS 3 THRU 6 TWICE.
8. INSTALL THE REAR BLOCKING ASSEMBLY.
9. INSTALL THE DOOR POST VERTICALS AND THE THREE DOOR SPANNERS.
10. INSTALL THE EIGHT STRUTS.

GENERAL NOTES

A. THIS DOCUMENT HAS BEEN PREPARED AND ISSUED IN ACCORDANCE WITH AR 740-1 AND AUGMENTS TM 743-200-1 (CHAPTER 5).

B. THE SPECIFIED OUTLOADING PROCEDURES ARE APPLICABLE TO LOADS OF MK-82 (500 POUND) BOMBS ON MHU-149/E METAL PALLETS. SUBSEQUENT REFERENCE TO PALLET UNIT HEREIN MEANS THE MHU-149/E METAL PALLET WITH MK-82 BOMBS INSTALLED. SEE PAGE 4 FOR DETAILS OF THE PALLET UNIT. **CAUTION:** REGARDLESS OF THE QUANTITY OF CONTAINERS TO BE SHIPPED, THE "MAXIMUM GROSS WEIGHT" OF THE END OPENING ISO CONTAINER MUST NOT BE EXCEEDED.

C. THE LOAD AS SHOWN IS BASED ON A 4,700 POUND 20' LONG BY 8' WIDE BY 8'-8" HIGH END OPENING ISO CONTAINER WITH INSIDE DIMENSIONS OF 19'-4" LONG BY 92" WIDE BY 93" HIGH, WITH A MAXIMUM GROSS WEIGHT OF 52,910 POUNDS. OLDER/OTHER CONTAINERS MAY HAVE A TOTAL INSIDE HEIGHT OF 85", BUT A CLEAR HEIGHT UNDER THE ROOF BOWS OF 93", VERIFY INSIDE CONTAINER HEIGHT PRIOR TO FABRICATING DUNNAGE. THE LOAD IS DESIGNED FOR TRAILER/CONTAINER-ON-FLATCAR (T/COFC) SHIPMENT, HOWEVER, THE LOAD AS DESIGNED CAN ALSO BE MOVED BY OTHER SURFACE MODES OF TRANSPORT. **NOTICE:** OTHER CONTAINERS OF THE SAME DESIGN CONFIGURATION CAN BE USED.

D. WHEN LOADING PALLET UNITS, THEY ARE TO BE POSITIONED SO AS TO ACHIEVE A TIGHT LOAD (TIGHT AGAINST THE DUNNAGE ASSEMBLIES). THE UNBLOCKED SPACE ACROSS THE WIDTH OF A LOAD BAY IS NOT TO EXCEED 1-1/2". EXCESSIVE SLACK CAN BE ELIMINATED FROM A LOAD BY LAMINATING ADDITIONAL PIECES OF APPROPRIATE THICKNESS TO THE LONGITUDINAL PIECES ON THE CENTER FILL ASSEMBLIES. NAIL EACH ADDITIONAL PIECE WITH APPROPRIATELY SIZED NAIL EVERY 12". ADDITIONALLY, THE LENGTH OF THE LATERAL PIECES IN THE CENTER FILL ASSEMBLIES MAY BE ADJUSTED AS REQUIRED TO FACILITATE VARIANCE IN THE SIZE OF THE PALLET UNIT.

E. DUNNAGE LUMBER SPECIFIED IS OF NOMINAL SIZE. FOR EXAMPLE, 1" X 4" MATERIAL IS ACTUALLY 3/4" THICK BY 3-1/2" WIDE AND 2" X 6" MATERIAL IS ACTUALLY 1-1/2" THICK BY 5-1/2" WIDE.

F. A STAGGERED NAILING PATTERN WILL BE USED WHENEVER POSSIBLE WHEN NAILS ARE DRIVEN INTO JOINTS OF DUNNAGE ASSEMBLIES OR WHEN LAMINATING DUNNAGE. ADDITIONALLY, THE NAILING PATTERN FOR AN UPPER PIECE OF LAMINATED DUNNAGE WILL BE ADJUSTED AS REQUIRED SO THAT A NAIL FOR THAT PIECE WILL NOT BE DRIVEN THROUGH ONTO OR RIGHT BESIDE A NAIL IN A LOWER PIECE.

G. IN SOME CONTAINERS THERE IS A SLOT AT THE CORNERS OF THE FORWARD WALL. PIECES OF DUNNAGE MATERIAL MUST BE LAMINATED TO THE BUFFER PIECES ON THE FORWARD BLOCKING ASSEMBLY TO PROVIDE A FLAT SURFACE FOR THE BUFFER PIECES. A PIECE OF 2" X 4", 2" X 3" OR A SPECIAL WIDTH PIECE CUT-TO-FIT CAN BE USED. THIS FILL PIECE WILL BE NAILED WITH ONE APPROPRIATELY SIZED NAIL EVERY 12". NOTE THAT SOME CONTAINERS ARE EQUIPPED WITH "TIE-BARS" IN THE CORNER SLOT, WHICH PRECLUDE THE USE OF A FULL HEIGHT FILL PIECE. WHEN "TIE-BARS" ARE PRESENT, THE FILL PIECE MUST BE INSTALLED IN SEGMENTS DESIGNED TO FIT BETWEEN THE "TIE-BARS" VERTICALLY. THE FILL PIECE(S) IS NOT REQUIRED WHEN THE CORNER PORTIONS OF THE CONTAINER FORWARD WALL ARE SMOOTH AND FLAT. DO NOT ALLOW ANY DUNNAGE ASSEMBLY TO CONTACT THE CONTAINER FORWARD WALL, ONLY THE CORNER POSTS OF THE CONTAINER SHOULD BE USED FOR FORWARD LONGITUDINAL BLOCKING.

(CONTINUED AT LEFT)

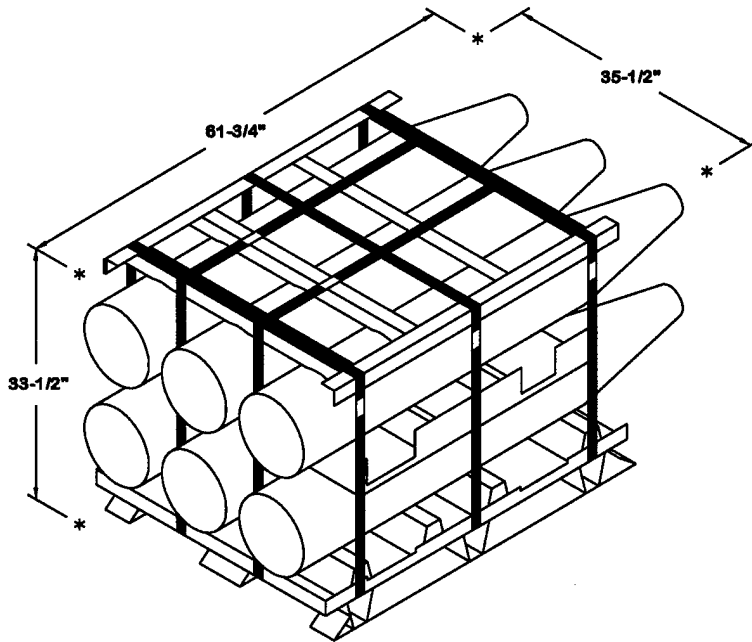
MATERIAL SPECIFICATIONS

LUMBER: SEE TM 743-200-1 (DUNNAGE LUMBER) AND FED SPEC MM-L-751.

NAILS: FED SPEC FF-N-105; COMMON.

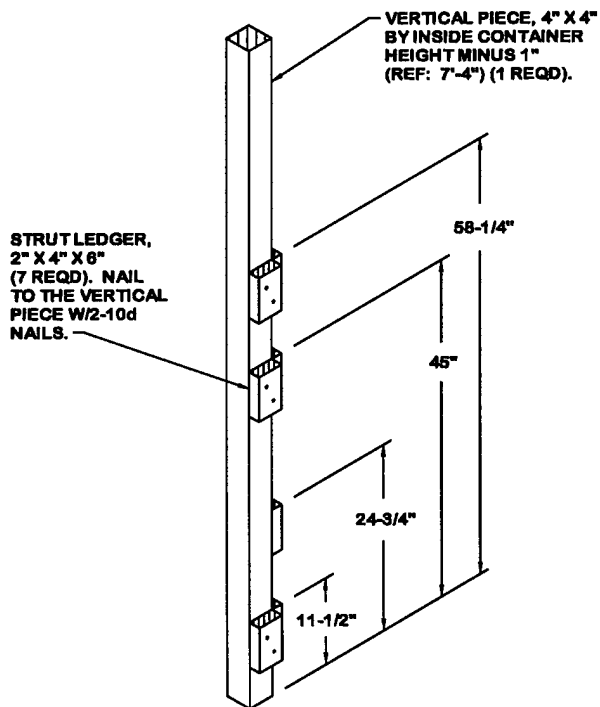
WIRE, CARBON STEEL: ASTM A253; ANNEALED AT FINISH, BLACK OXIDE FINISH, .0800" DIA, GRADE 1006 OR BETTER.

STEEL, STRUCTURAL: ASTM A501, STEEL STRUCTURAL TUBING; AND ASTM A570, STEEL, STRIP, HOT-ROLLED, GRADE 36 (MINIMUM).



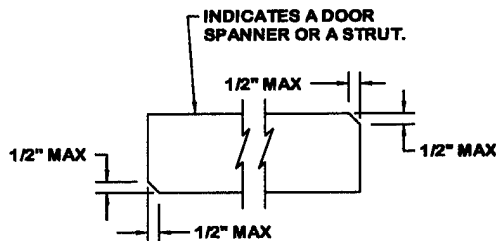
**PALLET UNIT DETAIL**

GROSS WEIGHT ----- 3,035 LBS (APPROX)  
 CUBE ----- 42.5 CUBIC FEET (APPROX)



STRUT LEDGER,  
 2" X 4" X 6"  
 (7 REQD). NAIL  
 TO THE VERTICAL  
 PIECE W/2-10d  
 NAILS.

VERTICAL PIECE, 4" X 4"  
 BY INSIDE CONTAINER  
 HEIGHT MINUS 1"  
 (REF: 7'-4") (1 REQD).



INDICATES A DOOR  
 SPANNER OR A STRUT.

**BEVEL-CUT**

IF DESIRED, EACH END OF A DOOR SPANNER  
 PIECE OR A STRUT MAY BE BEVEL-CUT AS  
 SHOWN ABOVE TO FACILITATE THE ACHIEVEMENT  
 OF A TIGHT DOOR-POST-TO-DOOR-POST OR REAR-  
 BLOCKING-ASSEMBLY-TO-DOOR-POST FIT.

**DOOR POST VERTICAL**

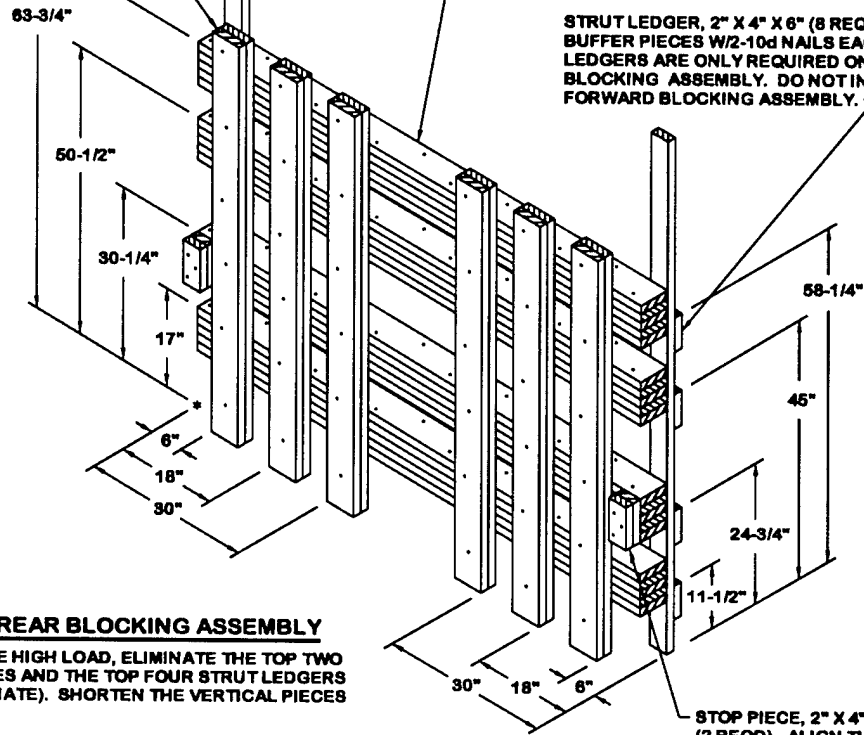
A LEFT HAND ASSEMBLY IS DEPICTED, A RIGHT HAND ASSEMBLY IS  
 ALSO REQUIRED. FOR A ONE HIGH LOAD, ELIMINATE THE UPPER TWO  
 STRUT LEDGERS AND THE UPPER DOOR SPANNER LEDGER. RELOCATE  
 THE MIDDLE DOOR SPANNER LEDGER AT 24-3/4".

VERTICAL PIECE, 2" X 6" X 70" (DOUBLED)  
(6 REQD). NAIL THE FIRST PIECE TO THE  
BEAM ASSEMBLIES W/3-10d NAILS AT  
EACH JOINT. LAMINATE THE SECOND  
PIECE TO THE FIRST W/6-10d NAILS.

BUFFER PIECE, 2" X 4" BY INSIDE CONTAINER HEIGHT MINUS 1"  
(REF: 7'-8" AT FORWARD END OF CONTAINER, 7'-8" AT REAR  
OF CONTAINER) (2 REQD). NAIL TO THE BEAM ASSEMBLIES  
W/3-10d NAILS AT EACH JOINT.

BEAM ASSEMBLY, 2" X 6" BY INSIDE CONTAINER  
WIDTH MINUS 1" (REF: 7'-7") (QUINTUPLED) (4 REQD).  
LAMINATE THE FIRST PIECE TO THE SECOND W/1-10d  
NAILS. LAMINATE EACH ADDITIONAL PIECE IN A LIKE  
MANNER.

STRUT LEDGER, 2" X 4" X 6" (8 REQD). NAIL TO THE  
BUFFER PIECES W/2-10d NAILS EACH. NOTE: STRUT  
LEDGERS ARE ONLY REQUIRED ON THE REAR  
BLOCKING ASSEMBLY. DO NOT INSTALL ON THE  
FORWARD BLOCKING ASSEMBLY.



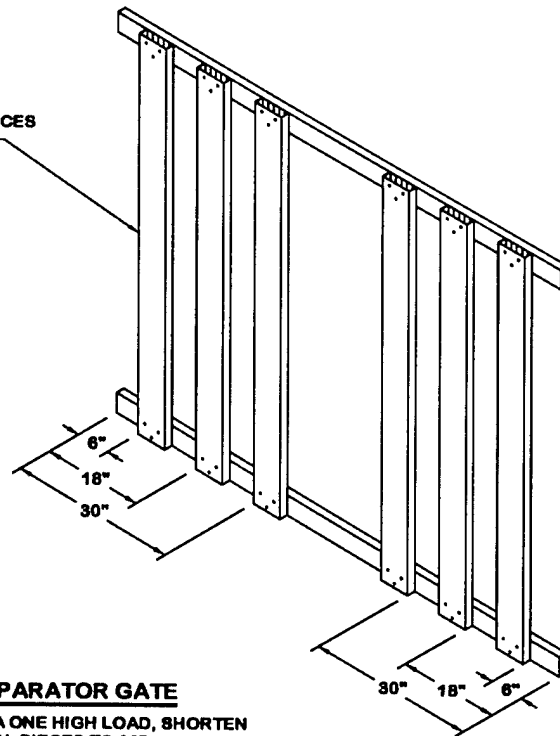
**FORWARD/REAR BLOCKING ASSEMBLY**

NOTE: FOR A ONE HIGH LOAD, ELIMINATE THE TOP TWO  
BEAM ASSEMBLIES AND THE TOP FOUR STRUT LEDGERS  
(WHERE APPROPRIATE). SHORTEN THE VERTICAL PIECES  
APPROPRIATELY.

STOP PIECE, 2" X 4" X 7-1/2" (DOUBLED)  
(2 REQD). ALIGN THE FIRST PIECE WITH  
THE CORNER OF THE BEAM ASSEMBLY  
AND NAIL TO THE BEAM ASSEMBLY  
W/3-10d NAILS. LAMINATE THE SECOND  
PIECE TO THE FIRST W/3-10d NAILS.

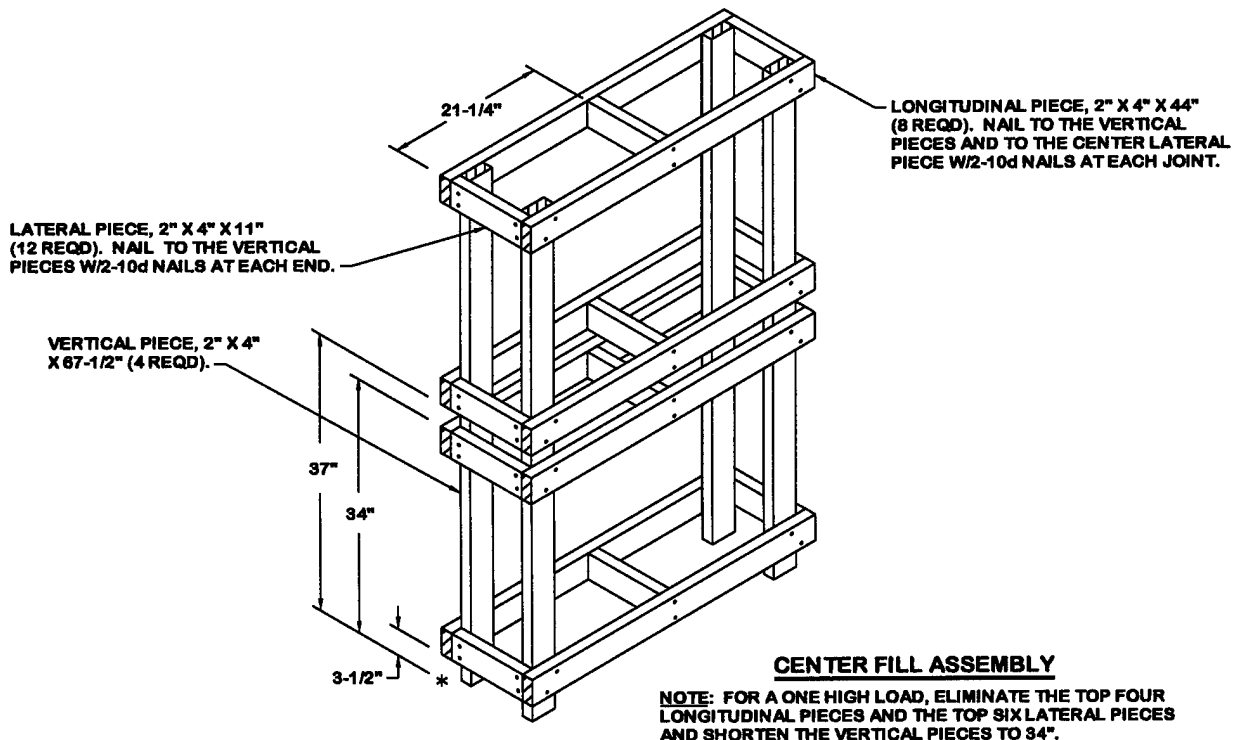
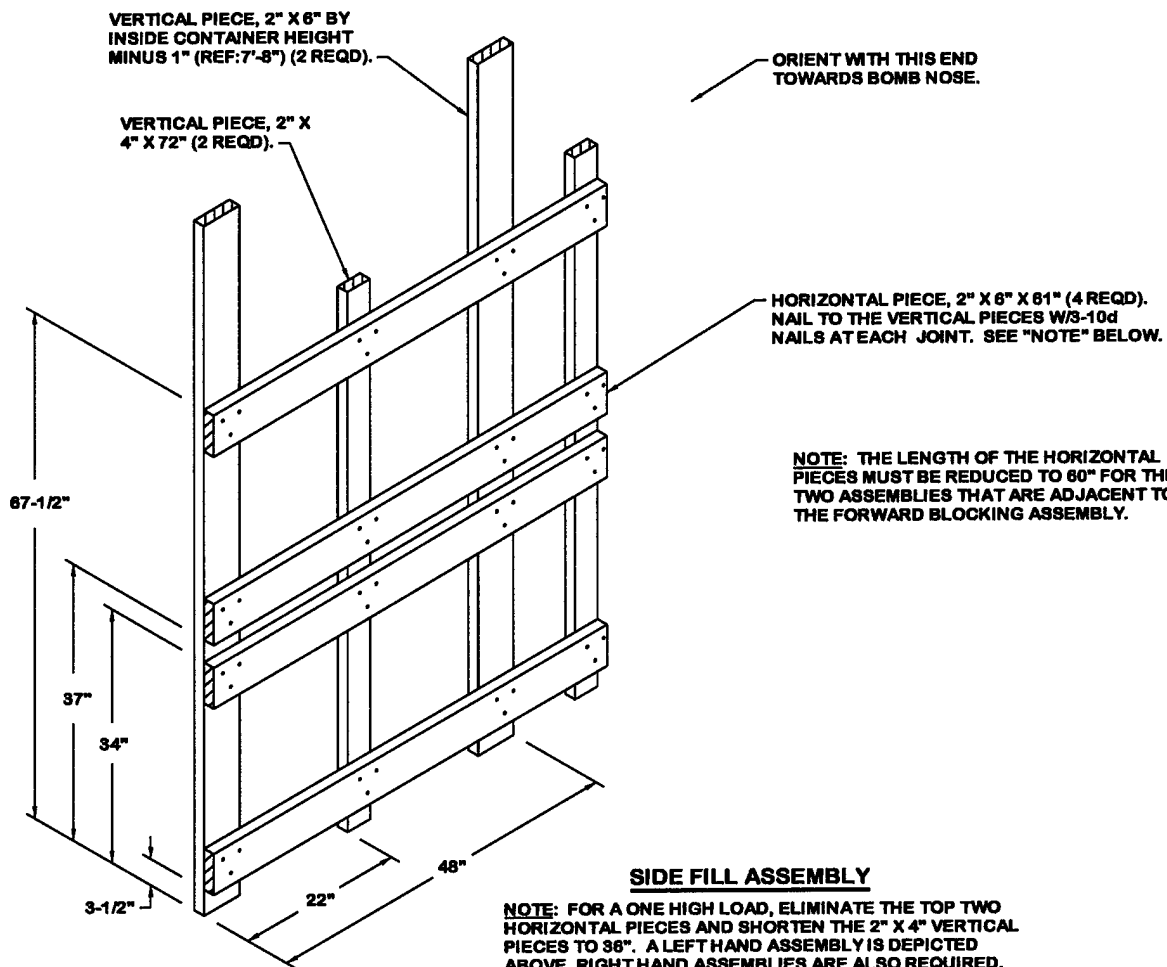
VERTICAL PIECE, 2" X 6" X 72"  
(6 REQD). NAIL TO THE TIE PIECES  
W/3-10d NAILS AT EACH END.

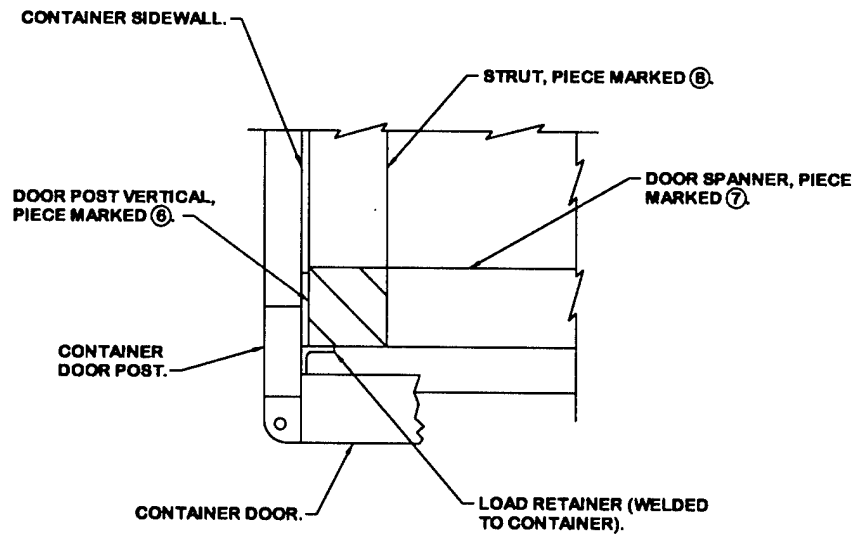
TIE PIECE, 2" X 4" BY INSIDE  
CONTAINER WIDTH MINUS 1"  
(REF: 7'-7") (2 REQD).



**SEPARATOR GATE**

NOTE: FOR A ONE HIGH LOAD, SHORTEN  
THE VERTICAL PIECES TO 36".



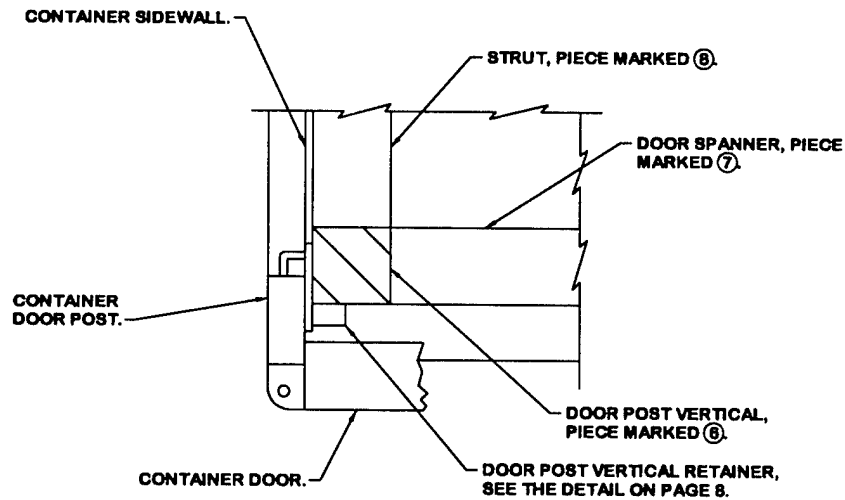


**DETAIL A**

A PARTIAL PLAN VIEW OF THE LEFT REAR PORTION OF THE CONTAINER IS SHOWN DEPICTING THE PROPER POSITION OF THE FILL MATERIAL AND ADJACENT DUNNAGE PIECES.

**SPECIAL NOTE:**

WHEN ISO CONTAINERS ARE NOT EQUIPPED WITH PRE-WELDED LOAD RETAINERS, AS DEPICTED IN "DETAIL A" ABOVE, DOOR POST VERTICAL RETAINERS WILL BE REQUIRED FOR THE LOAD DEPICTED ON PAGE 2. SEE VARIOUS LOADS WITHIN AMC DRAWING 19-48-4153-15PA1002 FOR EXAMPLES. SEE PAGE 8 FOR DETAILS OF THE METAL DOOR POST VERTICAL RETAINER.



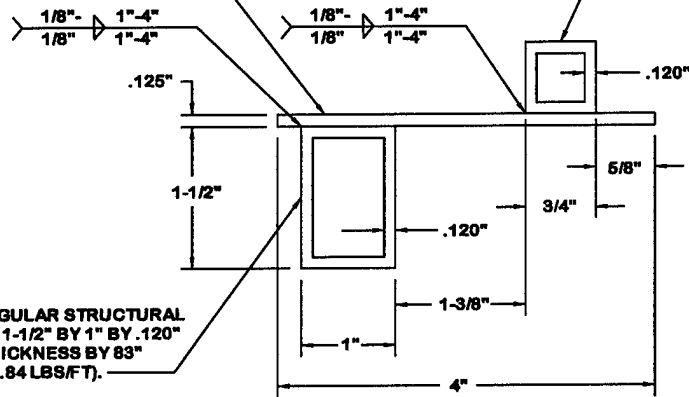
**DETAIL B**

A PARTIAL PLAN VIEW OF THE LEFT REAR PORTION OF THE CONTAINER IS SHOWN DEPICTING THE PROPER POSITION OF THE DOOR POST VERTICAL RETAINER AND ADJACENT DUNNAGE PIECES.

STEEL STRIP, 1/8" THICK BY 4" WIDE  
BY 83" LONG (1.70 LBS/FT).

SQUARE STRUCTURAL TUBING, 3/4" SQUARE  
BY .120" WALL THICKNESS BY 83" LONG  
(1.03 LBS/FT).

RECTANGULAR STRUCTURAL  
TUBING, 1-1/2" BY 1" BY .120"  
WALL THICKNESS BY 83" LONG  
(1.84 LBS/FT).



**VIEW A**

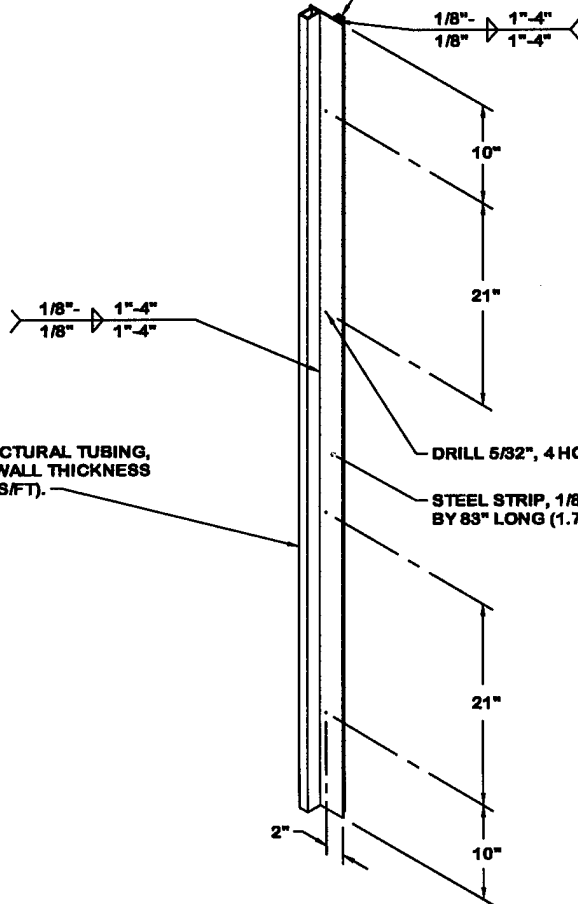
**VIEW A**

SQUARE STRUCTURAL TUBING,  
3/4" SQUARE BY .120" WALL  
THICKNESS BY 83" LONG (1.03 LBS/FT).

RECTANGULAR STRUCTURAL TUBING,  
1-1/2" BY 1" BY .120" WALL THICKNESS  
BY 83" LONG (1.84 LBS/FT).

DRILL 5/32", 4 HOLES.

STEEL STRIP, 1/8" THICK BY 4" WIDE  
BY 83" LONG (1.70 LBS/FT).



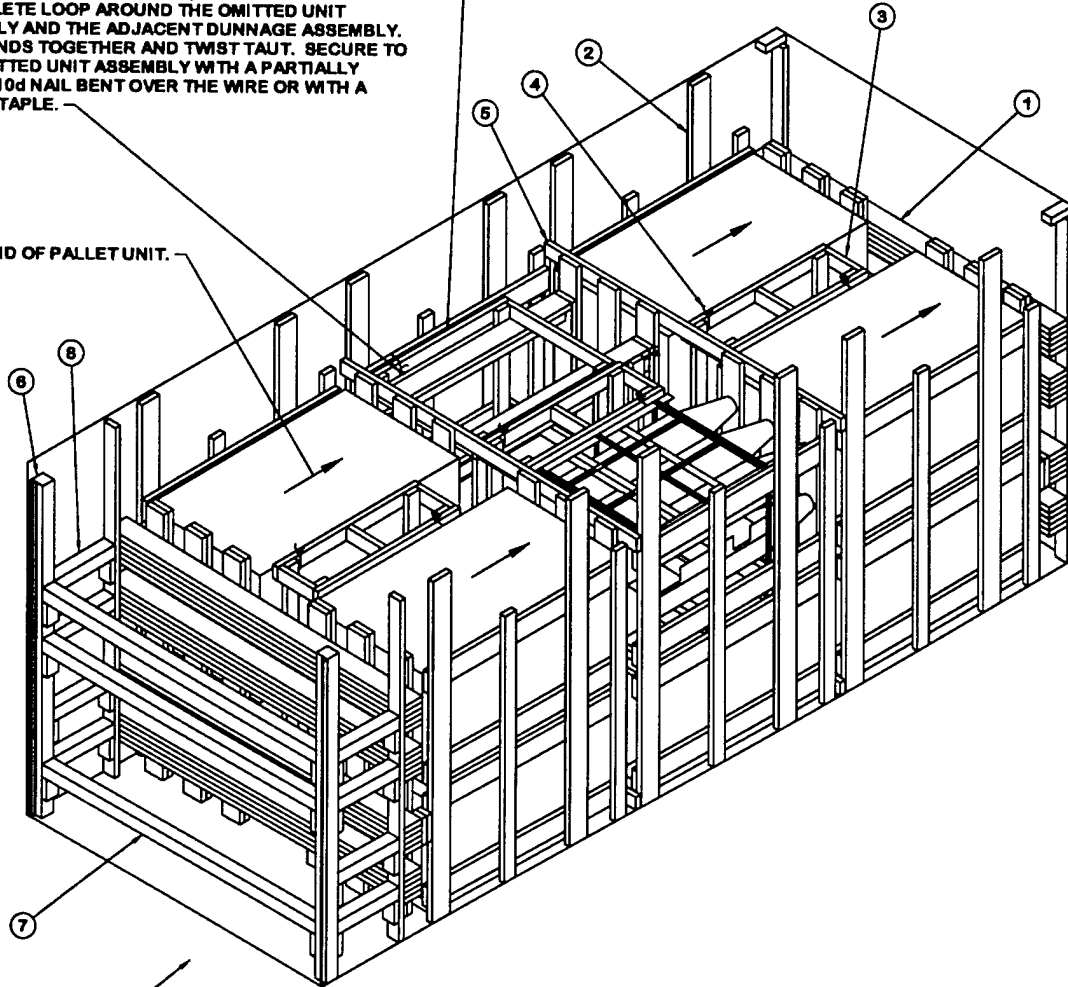
**DOOR POST VERTICAL RETAINER**

NOTE: THE ABOVE ASSEMBLY HAS BEEN SHOWN ROTATED 90° FROM THE ORIENTATION IN WHICH IT IS INSTALLED IN THE LEFT REAR CORNER OF THE CONTAINER. THE ASSEMBLY HAS BEEN ROTATED FOR HOLE LOCATION CLARITY.

TIE WIRE, NO. 14 GAGE WIRE 24" LONG (2 REQD PER OMITTED UNIT ASSEMBLY). INSTALL TO FORM A COMPLETE LOOP AROUND THE OMITTED UNIT ASSEMBLY AND THE ADJACENT DUNNAGE ASSEMBLY. BRING ENDS TOGETHER AND TWIST TAUT. SECURE TO THE OMITTED UNIT ASSEMBLY WITH A PARTIALLY DRIVEN 10d NAIL BENT OVER THE WIRE OR WITH A STRAP STAPLE.

OMITTED UNIT ASSEMBLY (1 SHOWN). SEE THE DETAIL ON PAGE 10.

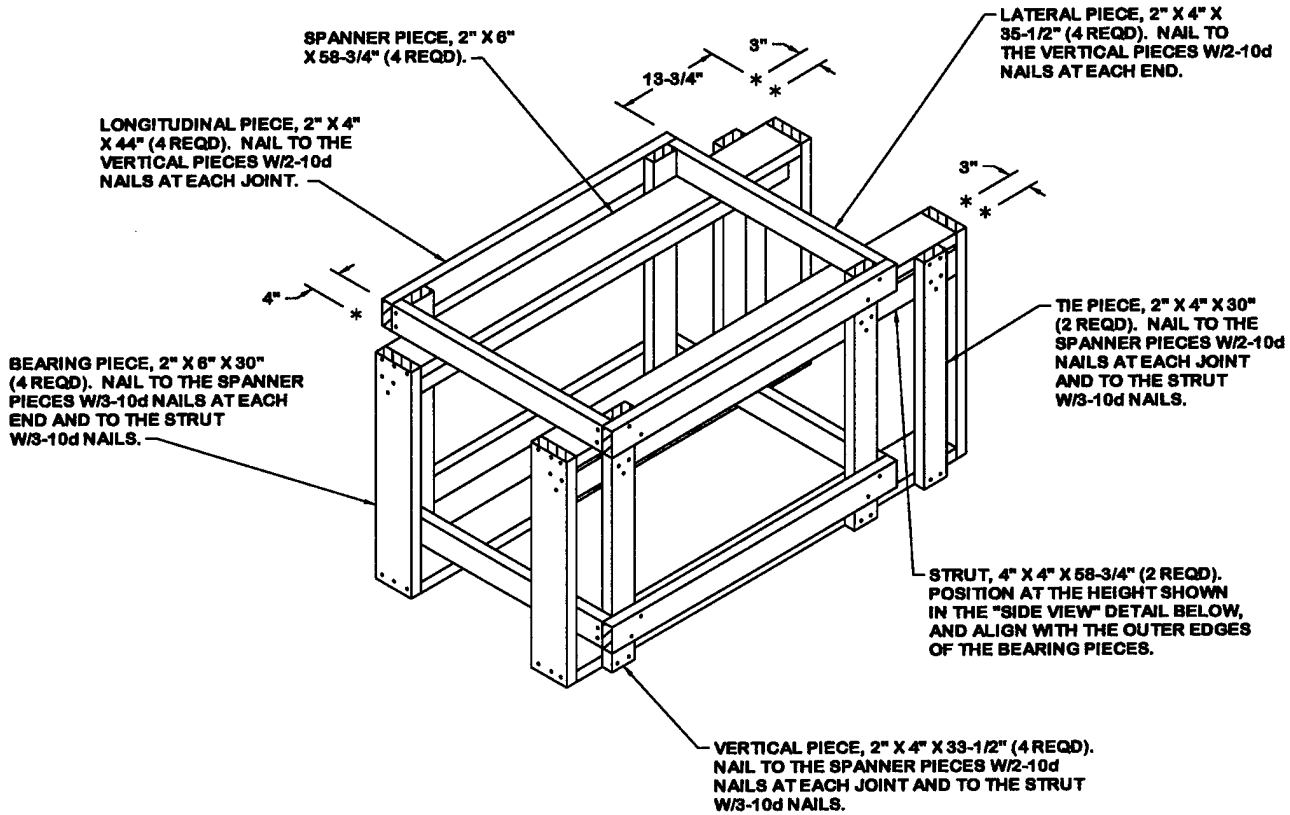
NOSE END OF PALLET UNIT.



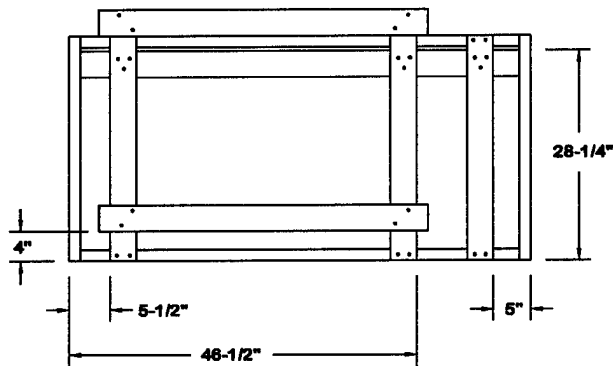
REAR OF CONTAINER.

**LESS-THAN-FULL-LOAD PROCEDURE**

THE DETAIL ABOVE DEPICTS A BLOCKING METHOD TO BE USED IN A LESS-THAN-FULL CONTAINER LOAD (LESS THAN 12 UNITS). KEY NUMBERS REFER TO KEY NUMBERS ON PAGE 2. SEE GENERAL NOTE "H" ON PAGE 3.



**OMITTED UNIT ASSEMBLY**



**SIDE VIEW**