



UNIVERSITY

DISTRIBUTION STATEMENT A
Approved for Public Release
Distribution Unlimited

**An Enduring Framework for
Assessing the Contributions
of Force Structure to a
Coercive Strategy**

ERIC A. BEENE, LT COL, USAF
School of Advanced Airpower Studies

20020910 115



An Enduring Framework for Assessing the Contributions of Force Structure to a Coercive Strategy

ERIC A. BEENE, Lt Col, USAF
School of Advanced Airpower Studies

THESIS PRESENTED TO THE FACULTY OF
THE SCHOOL OF ADVANCED AIRPOWER STUDIES,
MAXWELL AIR FORCE BASE, ALABAMA, FOR COMPLETION
OF GRADUATION REQUIREMENTS, ACADEMIC YEAR 2000-2001.

Air University Press
Maxwell Air Force Base, Alabama 36112-6615

July 2002

This School of Advanced Airpower Studies thesis is available electronically at the Air University Research Web site <http://research.maxwell.af.mil>.

Disclaimer

Opinions, conclusions, and recommendations expressed or implied within are solely those of the author and do not represent the views of Air University, the United States Air Force, the Department of Defense, or any other US government agency. Cleared for public release: distribution unlimited.

Contents

<i>Chapter</i>		<i>Page</i>
	DISCLAIMER	ii
	ABSTRACT	v
	ABOUT THE AUTHOR	vii
	ACKNOWLEDGMENTS	ix
1	INTRODUCTION	1
2	A FRAMEWORK FOR ANALYZING THE ENDURING REQUIREMENTS FOR MILITARY FORCE	7
3	ASSESSING THE CONTRIBUTIONS OF AIRPOWER TO A COERCION STRATEGY	27
4	ASSESSING UNMANNED AERIAL VEHICLE CONTRIBUTIONS TO A COERCION STRATEGY	45
5	CONCLUSIONS	69
 <i>Appendix</i>		
A	GLOBAL HAWK UNMANNED AERIAL VEHICLE SYSTEM CHARACTERISTICS	77
B	UNMANNED AIR COMBAT VEHICLE SYSTEM CHARACTERISTICS	79

Illustrations

<i>Figure</i>		
1	Decision Contexts and Objectives	8
2	Fundamental Objectives Hierarchy	10
3	Means-Objective Network	11
4	Fundamental Objectives Hierarchy for US National Security ...	13
5	National Military Strategy Hierarchy	15

<i>Figure</i>		<i>Page</i>
6	Schelling's Fundamental Objectives Hierarchy of Military Force	19
7	Completed Hybrid Hierarchy	21
8	Completed Capability-Means Network	33
9	Completed Credibility-Means Network	38
10	Completed Communications-Means Network	41
11	Teledyne Ryan AQM-34L	48
12	Global Hawk System Concept Overview	53
13	Global Hawk Vehicle	54
14	Means-Ends Networks for the Components of Coercion	56
15	UCAV System Concept	61
16	UCAV Air Vehicle	62
17	UCAV Support Segment	63
 <i>Table</i>		
1	Contributions of Global Hawk and UCAV to a Coercion Strategy	58

Abstract

The US Department of Defense is still struggling to define itself in the post-cold-war age—over a decade after the new period has begun. With a strategy and force structure review occurring on average every two years, the military has still not been able to generate a consistent basis on which to justify its force structure or its strategy. This study uses a decision analysis framework as a foundation for creating such a basis. Instead of depending on leadership for guidance, which changes with destabilizing regularity, this study relies on the theories of coercion that began in the cold war era. These theories have particular value today, especially in light of the many innovations the nation has undertaken in the past decade. Modified and translated for modern conventional warfare, these theories form the basis for a framework of enduring requirements for any military force that undertakes a coercive strategy. This study develops this framework to the operational level of analysis, and it is applied to two developmental air platforms, the Global Hawk Endurance Unmanned Aerial Vehicle and the Unmanned Combat Air Vehicle. The unique contributions of these two platforms become apparent using this framework, and the value of the framework is depicted as it points to areas for future improvement in these systems. Finally, the study makes a comparison between this framework and traditional analyses and strategy review processes, and it shows the unique and enduring value of this analytical framework for assessing the contributions of airpower platforms.

About the Author

Lt Col Eric A. Beene was born in Berea, Kentucky, in 1964. He graduated from the US Air Force Academy in 1986 with a Bachelor of Science degree in physics. After earning his navigator wings in 1988, Colonel Beene flew the FB-111A in the 715th Bomb Squadron, Pease Air Force Base (AFB), New Hampshire. In 1990, he transferred to the 55th Tactical Fighter Squadron, Royal Air Force (RAF) Upper Heyford, United Kingdom, where he flew the F-111E. While assigned to England, he participated in Operation Desert Storm, flying combat missions from Incirlik Air Base, Turkey. In 1993, Colonel Beene transitioned to the F-15E and an assignment with the 90th Fighter Squadron, Elmendorf AFB, Alaska in 1995. While assigned to Alaska, he participated in Operation Deny Flight over Bosnia. In 1996, Colonel Beene entered the Air Force Institute of Technology, where he earned a Master of Science degree in operations research. After graduation in 1998, Colonel Beene was assigned to Air Force Studies and Analyses Agency at the Pentagon, where he worked as a campaign analyst. Colonel Beene graduated from Air Command and Staff College in 2000 and the School of Advanced Airpower Studies in 2001. Upon graduation, Colonel Beene was assigned as director, Eighth Air Force Commander's Action Group, Barksdale AFB, Louisiana. Colonel Beene is married to the former Laura McDonald of Montgomery.

Acknowledgments

My thanks first go to my advisor and reader, Lt Col Forrest Morgan and Maj John Terino. The caliber of this study was enhanced by their attention to detail, in-depth knowledge, and commitment to excellence. If it adds to the military community's understanding of how to effect coercion, it does so largely with thanks to their efforts. Any shortcomings in reaching that goal are my own. I also thank the School of Advanced Airpower Studies (SAAS) faculty for giving me a lifetime's worth of education in a very short year. Although this study deals largely with coercion theory, it is a better study because of the efforts of every one of the SAAS professors who have guided my intellectual development over the past 10 months.

I must also thank the professors at the Air Force Institute of Technology who taught me what I know about decision analysis. Col Jack Jackson, Lt Col Jack Kloeber, and Dr. Dick Deckro laid the foundation long ago for what I hope has been a fruitful intellectual endeavor. I pray this study does their efforts justice.

I had the wonderful opportunity to work in Air Force Studies and Analyses Agency under Col Kurt Cichowski, another SAAS graduate. That environment taught me the value of clear thinking and even clearer presentation, and it also showed me gaps in the defense community's understanding of war fighting. I hope this study helps to fill in some of those gaps.

I also need to thank my mother and father, Joy and Paul Beene, and my sister, Paula, for providing a lifelong lesson in the value of education. Let no educational opportunity go unused, they stressed. Hopefully this study proves I have not.

Finally, I must thank my wife, Laura, for her patience, understanding, and intellectual and emotional assistance throughout the SAAS program. But for her this study would never have been completed. I only hope I can provide her the same level of support she has shown me.

Chapter 1

Introduction

In our broader effort, we must put strategy first, then spending. Our defense vision will drive our defense budget, not the other way around.

—President George W. Bush
February 2001

But then you have to take a look at the strategy, the acquisition policy, the strategy that goes with why are we going to have these systems? — and you kind of work backwards. What is it the United States military needs to do? And then, if you start there, then what sorts of systems does the United States military need to operate to carry out those sorts of missions?

—Rear Adm Craig Quigley
February 2001

President George W. Bush's call for a review of the nation's defense strategy early in his administration is only the latest in a series of attempts to reassess the basic defense strategy of the United States in the years following the end of the cold war. Like the others, this review is aimed at ensuring the nation's security strategy is in line with current and future world realities and US funding priorities. The underlying thrust of this review is its attempt to change the habit of unquestioningly funding a defense institution that was created and sustained during the cold war when the current global security landscape is so much different. It is an attempt to justify the US defense institution.¹

The decade-long list of searches for this justification includes the 1991 Base Force Review, 1993 Bottom Up Review, 1995 Commission on Roles and Missions of the Armed Forces, and 1997's Quadrennial Defense Review (QDR) and National Defense Panel. Prior to President Bush's call for a review, the Department of Defense (DOD) had already begun gearing up for 2001's iteration of the QDR, with a goal very similar to the one mandated by the new president. The QDR's focus—like that of the previous studies—is to estimate a baseline defense force that would be able to defend the most critical US interests in the most likely scenarios while maintaining a balance between risk and cost. In this effort, the driving consideration is the set of most likely scenarios US defense forces will be required to face. This has prompted many discussions of the nature of these scenarios, most notably the need for the defense force to be able to fight and win two nearly simultaneous major theater wars (MTW). The long-standing assumption is that this will be the most stressing situation for US armed forces; if they can accomplish this mission, they can accomplish any other foreseeable mission.²

Cold War Legacy

It is perhaps understandable that with the fall of the Berlin Wall, the dissolution of the Soviet Union as the only competing superpower, and calls for a "peace dividend," the United States should be searching for better and more efficient ways to organize, train, and equip its forces to protect the nation and its interests. It is also intuitively understandable that the forces that were created to defeat the great Soviet superpower present some measure of overkill in the current world situation. The defense reviews appear to have all commendable intentions to transform the current defense structure into something more appropriate to the current and future world situation.

However, the major limitation of any defense review is the fact that no matter how sweepingly one might like to change the defense structure, the United States is largely forced to operate with much of the force structure created during the cold war. Because acquisition programs typically take 15 years or more from the identification of a need to full-scale production of required weapons and systems, it is necessary to make an effort to define future needs early. Therefore, changes in defense equipment and strategy will likely be incremental at best and glacial at worst. The fear is that the global strategic situation will change before the United States can change its defense structure to maintain an ability to defend its interests.

This bequeathed force, however, is not without its own merit. In the immediate post-cold-war aftermath, the cold war force structure performed quite admirably in Operation Desert Storm. In this decidedly noncold war conflict, US forces surpassed most expectations of success in the conflict with surprisingly few losses. To be sure, there were shortcomings, notably the search for methods to defeat Iraq's Scud missile launches. On the whole, however, this force stood up quite well to the demands of the post-world-war conflict, a hopeful sign to those who would seek to ensure US dominance in the new strategic situation. Indeed, it is a scenario much like that which presented itself in Desert Storm that the DOD still holds as one of the two MTW yardsticks for measuring force effectiveness. If there are changes to be made, it is hoped that the United States can maintain its dominant position while executing its defense more efficiently and more cost effectively.³

The armed services strive to justify their force structure and seek ways to improve their abilities to carry out assigned missions, but their task is frustrated by several confounding phenomena. The procurement process for new equipment is quite lengthy, but the guidance for its development changes relatively frequently. Presidential administrations change every four or eight years, congressional majorities can change in two years' time, and political appointees with an input into the strategic policy process can change even more frequently than that. Such changes in leadership can produce corresponding changes in guidance for military leaders, forcing them to rethink and redesign defense strategies and policies formed during

the previous policy period. Furthermore, world threats change with increasingly rapid regularity, forcing the focus of defense strategies to change as well. While a Korean scenario and an Iraqi scenario still serve to guide the structure of the US defense force, twice in the last decade the United States has fought combat actions in the Balkans, and several other times the United States has foregone intervention in such troubled locations as Africa and the Asia-Pacific region. With guidance from the threat and from civilian leaders changing so frequently, it is difficult to maintain a consistent justification for any particular force structure long enough to have any meaningful impact on it. What we need is a steadier basis for designing enduring strategies and force structures, one that is at once proven by experience and flexible enough to endure foreseeable (and unexpected) future scenarios.

Toward a Modern Strategy Analysis Framework

Just as the cold war provided the United States with a dominant—if somewhat inefficient—force structure, the cold war period gave the nation some of the most academically rigorous and enduring theories of conflict in the history of the study of war. Unique to that period in history was a clear vision of who the enemy was, where the threat was likely to be, and how the United States might need to act to counter it. The great stakes of a possible nuclear confrontation between the world's two superpowers acted as a galvanizing agent, mobilizing civilian academia into research on how best to use nuclear weapons to maintain peace without escalating any confrontation into a globally catastrophic situation. While early works focused on deterrence theories using nuclear weapons, the Vietnam War showed the need for a coherent policy for conventional warfare that could preclude the use of nuclear weapons. A large body of literature followed. As the United States looks to transition from a cold war force structure to one better suited for a less threatening but more diverse political environment, these cold war-derived theories of conflict can offer insight into how best to make that transition.

The literature of the cold war period, especially during and after the Vietnam War, deals not just with the proper use of nuclear weapons against a superpower but also with other arms and other situations. More than simply discussing the damage these weapons can do, much of the literature of the period links that destruction with political reality. It links the means of conflict with the ends of conflict. One of the earliest modern treatises on how armed forces can or should be used to achieve political ends is *Arms and Influence* by Thomas C. Schelling. Published in 1966, early in the Vietnam period and with references to that conflict, it makes a modern connection between the existence of a nation's military forces and the ability of that nation to influence another. It was a work important to the period, laying the theoretical foundation for many future studies and for some of the strategies envisioned during Vietnam and after.

Although one might be loath to rely on theories that drove the development of strategies in the debacle that was Vietnam, that and subsequent conflicts provided a laboratory to help determine what can and cannot work against an intelligent enemy. Academic debate since then has provided even more insight into what military force can and should do and what it is ill equipped to do. Perhaps most significantly, post-Vietnam (and even post-Desert Storm) literature has focused on the political and military nexus of defense not just in terms of civilian control of the military, but in terms of national policy driving military action. We find ourselves not so far removed from Carl von Clausewitz's dictum.

That reconnection to military theory over one century old—the notion that war is an extension of national policy—is academically satisfying. It helps guide us in the search for enduring truths as we seek a more stable basis for creating a sound national strategy and a more stable foundation for building a suitable force for the current political landscape and that of the foreseeable future. It hints that there are concepts for the application of force that endure not only generations of humans, but generations of leaders and generations of weapons. Identifying those enduring requirements for force, suitable for America's national strategic goals and the global political environment, will aid the nation immensely as it reviews its strategy and its force structure. That is the goal of this study.

This thesis will attempt to translate some of the theory developed during the cold war era into modern terms that make it relevant to strategies and force structures today. In doing so, it will create a paradigm for stability in the defense planning process that maintains the core essence of the defense structure but relies on the political-military nexus for effective defense strategies. By using modern decision analysis techniques to distill the essential from the debatable, we can create a framework for assessing the contribution of force structure toward achieving national strategic goals and the contribution of strategy toward achieving national policy goals.

Chapter 2 will present the essential elements of decision analysis, including its definition, its benefits, and its application in this situation. It will assess the most recent version of the US national strategy, breaking it down into a hierarchy to provide organization and focus. It will highlight the unique nature of US national strategy from a decision analysis perspective and create a basic paradigm by which to assess specific strategies and the force structure that will support those strategies. It will then add a more consistent foundation on which to base strategic decisions from the academic literature developed during the cold war. It will answer the question, "What are some of the necessary elements of national strategy that a US military force must be able to accomplish?"

Chapter 3 will break down the elements of national strategy in a specific context. For the purposes of this study, a coercion strategy will be considered wherein the United States seeks to compel an adversary to reverse its military action against a friendly state. The necessary and sufficient conditions of such a campaign will be discussed, with emphasis on

the military contributions to that strategy, especially air force elements of the military. It will answer the question, How can military force, especially airpower, contribute to a strategy of coercion in a specific context?

Chapter 4 will concentrate not on an overall strategic review of the type currently being discussed but on the specific case of the development of unmanned aerial vehicles (UAV). Although UAVs and remotely piloted vehicles have been in use since the 1940s, current programs are circumventing the traditional acquisition process in an effort to field more revolutionary technologies sooner than they might otherwise. The motivation behind this is that technology is changing at such a rapid pace, the traditional acquisition time frame might tend to render—obsolescent—such airframes before they become operational. By capitalizing on technology early, advocates hope this type of weaponry can help the United States maintain its strategic edge in world affairs. In the end, however, it is not necessarily the technology employed in the strategy that is crucial, but how it fits into a useful strategy. Even the most modern technological marvel cannot guarantee success to a strategy that is incomplete. This chapter will answer the question, “How can UAVs contribute to an effective coercive air strategy?”

Chapter 5 will provide overall conclusions for this analysis and suggest future studies and areas of research. It will summarize the findings of this study, and it will answer the question, What should be the guiding principles of future strategy development and force structure assessment?

It is hoped that this work is not a conclusion but a continuation of the theoretical work begun not during the cold war, but even before that with Carl von Clausewitz in his observations of napoleonic warfare. Although he never envisioned the existence of enduring principles to guide warfare, he absolutely envisioned a need for continuous study and reflection on the nature of warfare, conflict, and violence. I hope that this work continues in that vein.

Notes

1. Jonathan S. Landay and Ron Hutcheson, “Bush Orders Defense Review,” *Philadelphia Inquirer*, 10 February 2001, 1.

2. The discussion of this as the most stressing scenario dates back to Les Aspin, secretary of defense, Report on the Bottom Up Review (Washington, D.C.: Department of Defense, October 1993), 7–9.

3. *Ibid.*, 14. The other major threat war is a Korean scenario.



Chapter 2

A Framework for Analyzing the Enduring Requirements for Military Force

Value-focused thinking essentially consists of two activities: first deciding what you want and then figuring out how to get it. In the more usual approach, which I refer to as alternative-focused thinking, you first figure out what alternatives are available and then choose the best of the lot. With value-focused thinking, you should end up much closer to getting all of what you want.

—Ralph L. Keeney
Value-Focused Thinking

Decision analysis, of which Keeney's *Value-Focused Thinking* is a very well-developed example, is a methodology for thoughtfully structuring decisions based on clearly articulated values.¹ It provides a framework to relate the desired objectives in a decision context to the means used to achieve those objectives and to the values that determine the relative worth of the available alternatives. It requires that decision makers first define what qualities constitute a good decision in a strategic context, then use that definition to generate alternatives and compare them in specific decision contexts. By creating this definition or this decision-making framework, decision-making criteria can be made more consistent and more readily defensible.

The utility of using decision analysis lies in demanding that decision makers acknowledge the basis for choosing one alternative over another. It requires a transparency in the decision-making process. When done correctly, it can point out faulty logic and hidden values and priorities. It provides a foundation for communicating decision logic to interested parties and therefore provides a foundation for reasoned discussion of alternatives. Perhaps most importantly, decision analysis provides a means to generate and compare decision alternatives.

Another benefit of decision analysis is its focus on decision opportunities. The alternative to Keeney's value-focused thinking is alternative-focused thinking, which waits for a decision problem to arise, generates alternatives to solve the problem, and chooses one based on a logic born of exigent circumstances. Typically, in alternative-focused thinking, the optimal choice is that which can be accomplished most expeditiously, or most inexpensively, or with minimum external input. Value-focused thinking—in addition to helping solve decision problems with previously considered decision criteria—also helps create decision opportunities. Whenever a situation arises that offers alternatives within established decision criteria, it provides

an opportunity to choose a new alternative—and thus a better result—without having to wait for a decision problem to present itself.

Decision Analysis Framework

Decision analysis typically begins by identifying the decision contexts, both strategic and specific. As one might expect, the strategic decision context is very general and relates to the long-term viability of an organization. Corresponding to the strategic context is a set of strategic objectives, typically driven by the decision maker. These objectives help to frame the context and drive the selection not just of alternatives, but of decision opportunities. Likewise, the specific decision context is framed by a set of specific objectives. These, of course, derive from the broader strategic objectives but are narrower in scope. Even narrower in a decision opportunity may be a set of means objectives that further narrow the decision context. These means objectives may limit the alternative to certain means appropriate for the context. A graphical relation between these contexts and objectives is shown in figure 1. The letters A, B, and C correspond to readily available decision alternatives. Note that for a given specific decision context, even constrained to a set of means objectives, there may exist within the space many more alternatives than the three represented.

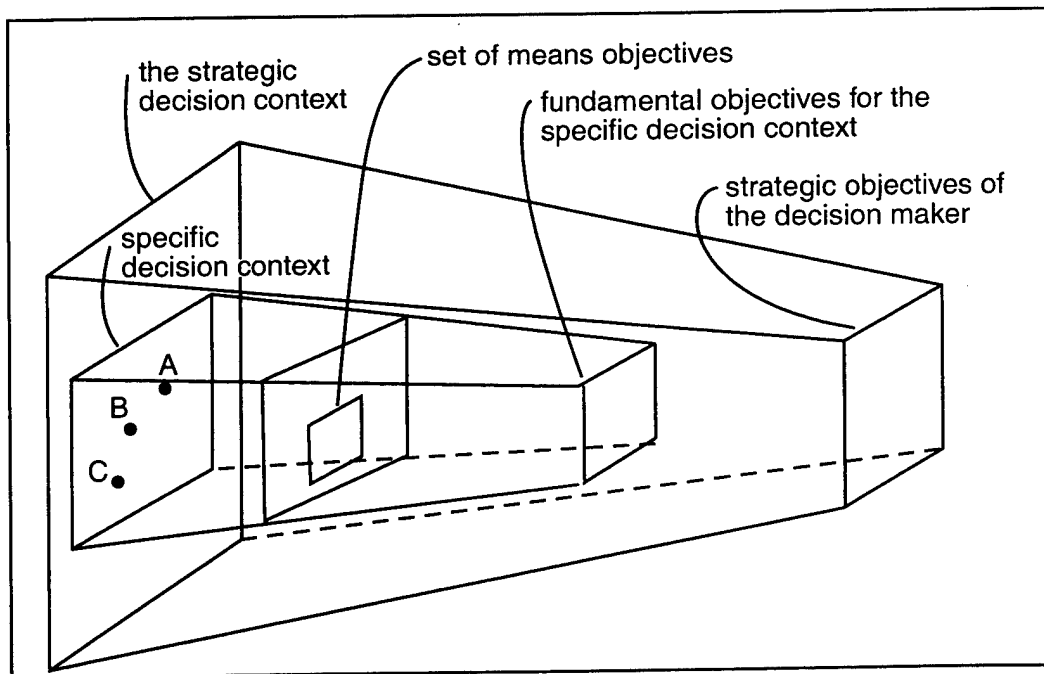

Figure 1. Decision Contexts and Objectives

As both the discussion above and the figure imply, framing the contexts and the objectives can be an iterative process. Specific objectives for one context may constitute strategic objectives for a more narrow decision context. The next step in the decision analysis process is defining both the fundamental objectives (and the specific objectives) and the means objectives. This is accomplished using two similar logical structures.

The fundamental objectives hierarchy typically begins with a single overarching objective, from which subobjectives derive. This is a simply stated goal for the organization and the decision maker. Each subobjective is a more specific statement, or clarification, of the overarching objective. For each superior objective, there must be at least two subobjectives—if there are any. The logical key to this hierarchy is that when the hierarchy of fundamental objectives is complete, the lowest level of subobjectives constitutes a collectively exhaustive set of objectives, each supporting the ultimate objective, and all the subobjectives are mutually exclusive. That is, no subobjective replicates any other subobjective on the same logical level.

Figure 2 shows the logical connection between the hierarchical levels of objectives. Each objective 1, 2, and 3 directly supports the achievement of objective A, the overarching objective. Each objective 1, 2, and 3 directly supports objective 1, but not objectives 2 or 3. Objectives 2 through 7 are complete, with no supporting subobjectives. Objectives A and B are required to further elucidate objective 1, however. Each subobjective narrows the definition of the objective above it. At the very lowest levels, the objectives define the values by which alternatives can be measured. This begs the question, when is the objective hierarchy complete? In general, it should be defined to as low a level as required to help inform the decision. When dividing objectives further would not aid in the decision process, the required level of detail has been reached. Until this useful level is reached, and until mutual exclusivity and collective exhaustion are demonstrated, the hierarchy is quite useful in pointing out holes in the decision logic and missing objectives and subobjectives.

The next step in the decision-analysis process is creating a means-objective network. This structure looks very similar to the hierarchy in figure 2, but it is logically different.² The overarching objective is a means objective or a general task to be performed. Each lower level specifies how the objective is to be accomplished, or the means by which the objective will be achieved, with increasing detail. An important difference between the objectives hierarchy and the means-objectives network is that the means, or the lower levels of the hierarchy, are not limited to supporting only the objectives or means directly above it. As figure 3 illustrates, means that support, or influence, higher level means are not restricted to influencing only those immediately above it. Furthermore, there can be influence between the means at any one level, as shown by the arrows in figure 3.

When complete the means-objectives network will list a host of means by which to accomplish each objective. It will also aid in the creation of alternatives, showing which means support which objectives and those that

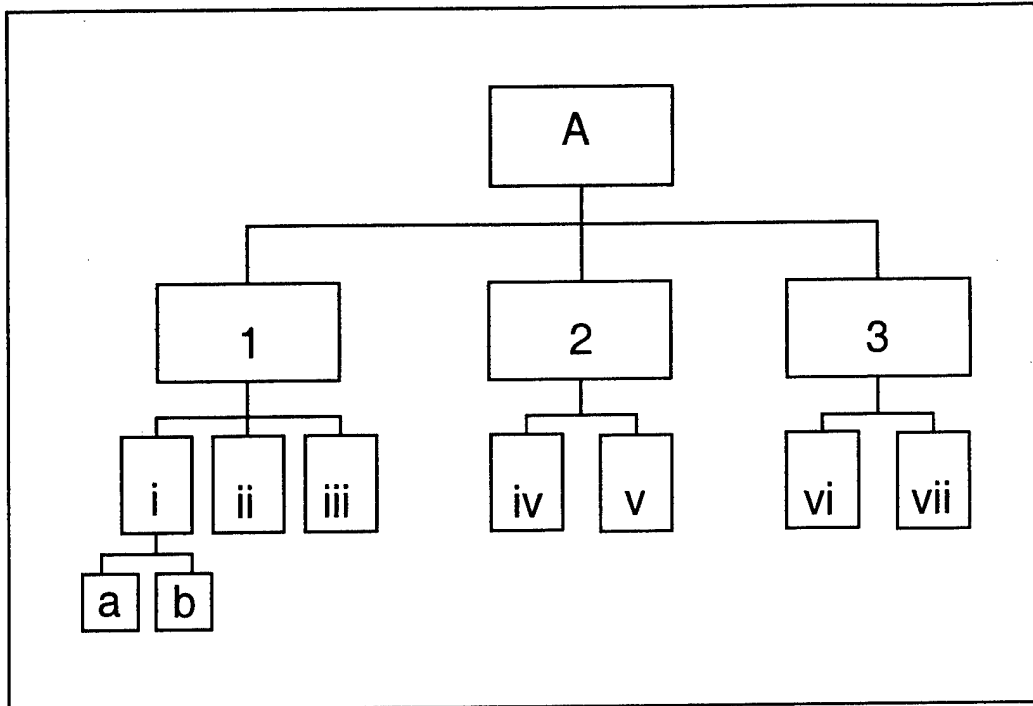

Figure 2. Fundamental Objectives Hierarchy

do not. Since there are interrelationships between the means and the levels, there is clearly no mutual exclusivity among the various means. Unfortunately, neither is there a requirement for collective exhaustion. However, that can be a strength—there are often unidentified means of accomplishing an objective; decision opportunities allow decision makers to identify them. In fact, the appearance of a new means can itself constitute a decision opportunity.

It should be apparent that there is an interactive logic between the two decision structures. The figures shown indicate that the means-objective network shown in figure 3 supports objective 1 from figure 2. It is quite likely that several objectives in the objectives hierarchy will be supported by a means-objectives network. Some objectives in the hierarchy will be fundamental qualities to be desired in any decision situation, but many other objectives will be ends that require means of accomplishment. Theoretically, for each objective in the objectives hierarchy, there may exist a unique means-objectives network. Also, as shown above, the means to accomplish one objective may also help accomplish another objective.

Sometimes overlooked in the literature is the existence of a hybrid hierarchy, a combination of the objectives hierarchy and the means-objective network. In some complex cases, the means themselves may be specified as objectives or elements of inherent value. Sometimes cultural biases or other motivations dictate that an action should be taken regardless of the

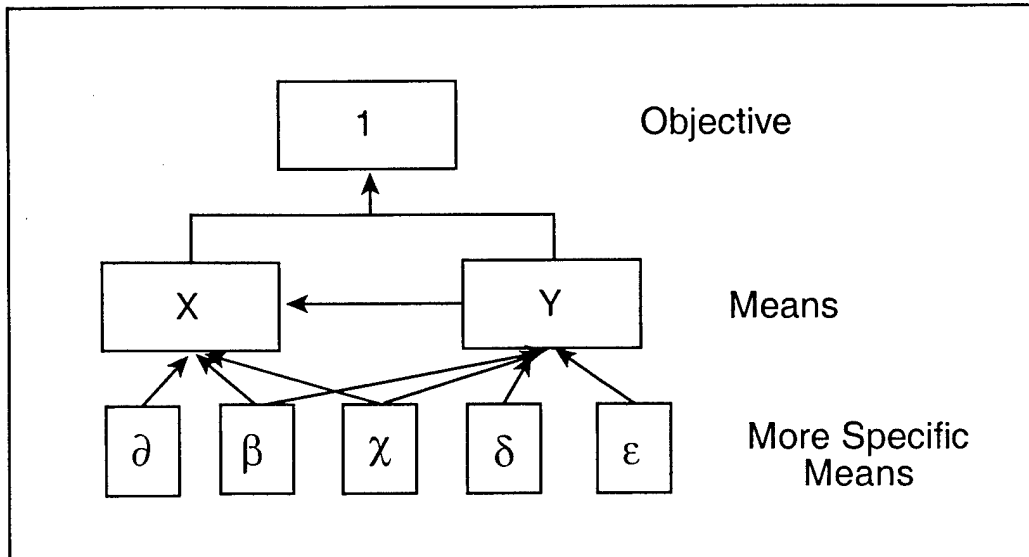

Figure 3. Means-Objective Network

objective it supports, creating a means that is in itself an objective. In other cases, complex political situations may drive actions that are beyond the control of the decision maker in question, also creating means that are essentially objectives themselves. Typically, the more complex the strategic decision context is, the more likely this is to occur.

The pure fundamental objectives hierarchy can be used to generate a value hierarchy. Each of the objectives and subobjectives in the hierarchy is desirable in the strategic and the specific decision context. Therefore, the more nearly an alternative achieves the subobjectives, and thus, the overarching objective, the better the alternative is. By measuring the degree an alternative achieves an objective, that alternative can be compared to other alternatives. To measure an alternative, the objective hierarchy can be used to generate a value hierarchy, wherein each subobjective (at the lowest level) is measured, either directly or with a proxy measure. The value hierarchy can then be used to calculate an objective function, a mathematical tool for measuring alternatives quantitatively. This objective function makes it possible to measure the contribution of any individual alternative toward achieving the overall objective.

This quantitative measure can be quite useful for assessing alternatives in a decision context and comparing them, but for several reasons this quantitative measure is beyond the scope of this study. Creation of the value hierarchy, even more so than the creation of the fundamental objectives network, is painstaking business requiring the full attention of the decision maker(s) and a precise statement of the relative worth of each subobjective in the hierarchy. Not only is this work problematic when there are many decision makers but it is also of limited value when the

decision maker changes thus rendering the value preferences within the hierarchy void until reassessed and confirmed. For this reason, decision analysts typically require high-level buy-in and agreement on the fundamental objectives hierarchy and the resultant value hierarchy. Agreement at this level provides a less impeachable standard for decision making at all levels of the organization.

Particular difficulty arises, however, when applying the decision analysis methodology, especially in its quantitative form, to organizations with complex decision-making mechanisms like the US government. Recalling the goal of the national security strategy reviews discussed in chapter 1, we seek a stable basis on which to make decisions on how best to organize, train, and equip US forces to support the national strategy. This basis should be one that will tend to outlast the acquisition programs it generates. It should provide guidance to lower-level decision makers facing specific decision contexts, and it also should help guide the higher-level decision makers as they face strategic decision opportunities. Difficulty arises when strategic-level decision makers change with alarming regularity. Presidents can change every four years. Cabinet secretaries can change more frequently, or can even be absent until US Senate confirmation. Uniformed military leaders can change annually or even more frequently.

This change in leadership at the decision-making level makes it difficult to create any sort of stability in the strategic decision process. National and international political realities further cloud the issue, making it difficult for any level of decision maker to state enduring objectives and values that will not create political liabilities in the future. The qualitative logic of decision analysis, however, can help us determine lasting strategic priorities and requirements. We desire a consistent hierarchy, one that does not change with changes in leadership. Although there are few fundamental objectives to which the nation is committed, we can use those that do exist to begin the hierarchy, then we can appeal to rigorous academic theory generated over the past 50 years to help fill in the rest of the hierarchy.

Applying the Framework to the Strategy Process

A *National Security Strategy for a New Century (NSS)* is one of the few overarching documents to guide the creation of a fundamental objectives hierarchy. It is an unclassified document produced annually by the White House to list the basic security objectives of the United States and the general means by which the nation will pursue them. In prose form, it is the highest-level structure of the objectives hierarchy. Decision analysis will allow us to build that hierarchy graphically and logically and will show us any holes in the logic.³

The strategic context of the NSS is clearly the national security of the United States. The specific decision contexts are likely to be regions of the world where US national security and interests are threatened and must

be protected and defended. The types of specific decisions are likely to be what type of force to be used and how is it to be used. These considerations, however, will be saved for later. The overarching goal of the national security strategy is to sustain the role for the United States as being “the world’s most powerful force for peace, prosperity and the universal values of democracy and freedom”—in short, to maintain US preeminence in the world. The NSS document breaks these elements down into three “core objectives: to enhance America’s security; to bolster America’s economic prosperity; [and] to promote democracy and human rights abroad.”⁴ This hierarchy is shown in figure 4.

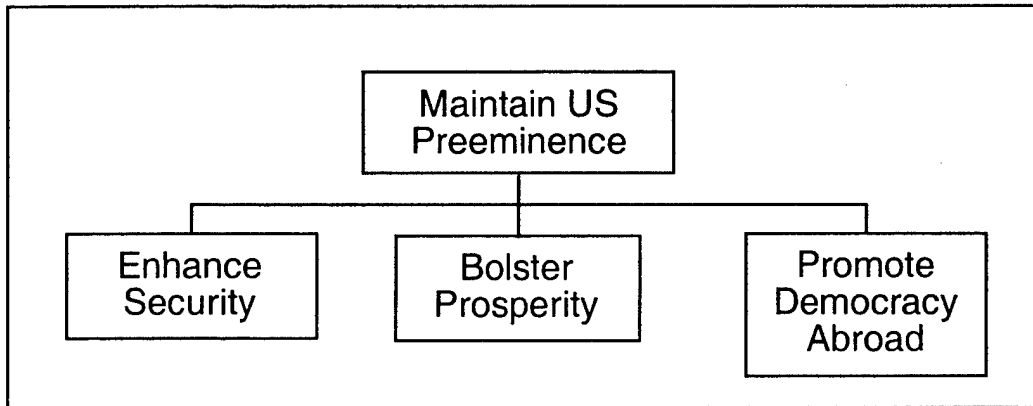

Figure 4. Fundamental Objectives Hierarchy for US National Security

For the purposes of this study, which is concerned with the organization, training, and equipping of the armed forces, we will concentrate on the first objective—enhancing security at home and abroad. Indeed, armed forces may be an element of the means of achieving the other objectives, but they will absolutely be required to enhance US security abroad. This study focuses on the necessary elements of strategic policy for guiding military strategy, and the first objective is the primary objective for the armed forces.

One of the results of the 1997 Quadrennial Defense Review (QDR) is the now standard paradigm for maintaining US security, constituting the next level in the hierarchy under the first objective: shaping the international security environment, responding to threats and crises, and preparing for an uncertain future.⁵ In fact, these are the means by which to achieve the first objective. However, as they are included in the NSS document, they clearly have a level of authority that establishes them as objectives for the purposes of guiding the armed forces. Not surprisingly, therefore, the US national security strategy hierarchy is a hybrid, including both fundamental objectives and means. This clearly poses problems for traditional

decision analysis: the means in this case, while collectively exhaustive as far as the military is concerned are not mutually exclusive. Intuitively, shaping the international environment can have a significant influence on how the United States can respond to threats to security. Shaping will also be influenced by the preparations taken in anticipation of the uncertain future. As these three means of achieving the objectives are not mutually exclusive, subordinate means that contribute to one will likely contribute to others. Moreover, as these are both means and objectives, they do not have a measurable value or a clear meaning of the actions required. More levels are needed.

The NSS document is less helpful in filling in the next level. Under "Shaping," it concentrates on the integrated approaches required to help make the world a more secure place for US interests. The "Preparing Now" section speaks of transforming the armed forces to take advantage of technological progress while maintaining an ability to shape and respond while maintaining a modern force. The "Respond" objective focuses exclusively on the scenarios to which armed forces (and other instruments of national power) may be required to respond, including homeland threats, small-scale contingencies, and MTW. While useful to guide some elements of strategic planning, none of the prose surrounding these three means of enhancing security offers much in the way of clear means or clear objectives. The NSS does not say more precisely what to do, or even why to do it. At best, it points to when action will be required.

The most recent *National Military Strategy (NMS)* provides a little more useful elucidation. It lists the military's objectives as "promoting peace and stability and defeating adversaries." It recalls the "shape, respond, prepare now" paradigm as the means for accomplishing these objectives, which serve as a suitable substitution and elucidation to the "enhance security" objective of the NSS. It goes on to define more clearly the subobjectives under each of these three. This portion of the hierarchy is shown in figure 5.

While more informative than the NSS document (and logically so, as it deals with a much more reduced portion of the government), this is still less than satisfying academically, as it does little to provide hard objectives and means for achieving those objectives. Clearly, the US military will respond to international crises, but what precisely is it to accomplish in these crises? Security reviews, security documents, and even security guidance have all concentrated on defining likely future scenarios for the military to encounter, without providing direction on precisely how to counter these threats. That typically is left to the theater commander, which, as previously mentioned, changes with frightening regularity. Furthermore, unique to the US national security situation in the post-cold-war era, these theaters are so widespread as to constitute vastly different scenarios. When the goal is consistency and constancy, this document provides further guidance. Tools of execution and strategies for accomplishing the objectives are left to the theater commander.

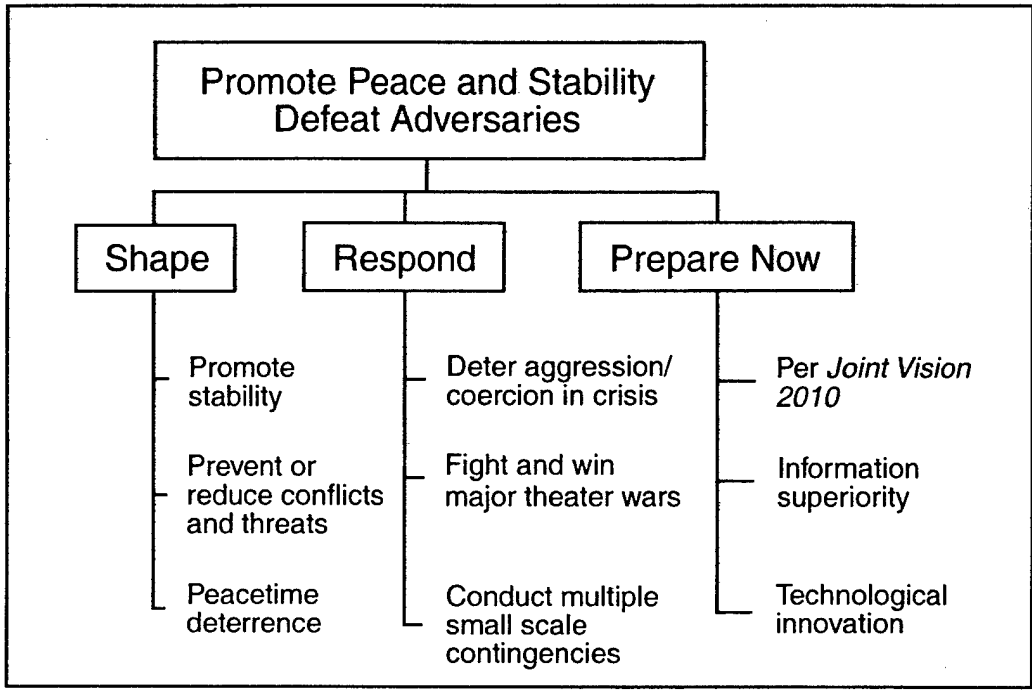

Source: John M. Shalikashvili, *Shape, Respond, Prepare Now: A National Military Strategy for a New Era* (Washington, D.C.: Joint Chiefs of Staff, 1998), 12-18.

Figure 5. National Military Strategy Hierarchy

Invoking Theory

There is a yet untapped source of guidance. The stress of impending nuclear doom mobilized all manner of theorists to consider the nature of war and conflict during the cold war, with an eye toward using force in a reasoned way to prevent escalation. Although much of the literature of this period focused on nuclear deterrence, many chapters and volumes also considered the nature of war itself, and the meaning of conventional warfare. From this period of rich academic theory we can borrow a rigorously analyzed foundation for making decisions on when and how to engage military forces that carries a well-established provenance and finds general acceptance throughout military and civilian institutions. In the absence of other guidance, we will use this body of thought to direct our search for an enduring framework to organize, train, and equip military forces.

Thomas C. Schelling provides a useful foundation for a theory of how armed forces can be used and what it can and should accomplish. His book *Arms and Influence* describes a useful taxonomy of how armed forces influence adversaries that applies today. Written in 1966, Schelling's book described what military power could do and why. The emphasis at the time was on nuclear war and deterrence, but the book's focus—as it appeared

early in the Vietnam conflict—was on the avoidance of escalation and fighting wars without employing nuclear weapons. This influential book, and the many others it spawned, had many of its theories tested during Vietnam. His notions of gradualism and the need to apply force in signal-sending increments has since gathered a somewhat notorious reputation, but many of the underlying elements of his theory still provide great utility. His fundamental theory of the difference between brute-force warfare and coercion still informs the basic argument for using and maintaining military forces, and it provides a useful set of means and objectives with which to continue our hierarchy.⁶

Most usefully, Schelling created an acceptable taxonomy for the use of force that is revealing. At the most fundamental level, he identified two uses for military force in a conflict: brute force and coercion. The difference between the two is the “difference between taking what you want and making someone give it to you.”⁷ A brute-force application of power by nation A against nation B succeeds by causing adequate destruction of nation B’s forces so that he cannot prevent nation A from pursuing its goals. It renders the adversary, if not harmless, at least nonthreatening. It is somewhat akin to Clausewitz’s notion of absolute war and the complete defeat of the enemy’s army.⁸

Coercion, on the other hand, consists of making the adversary decide not to oppose the opponent’s action. It differs from brute force in that the adversary still has an ability to oppose action but consciously chooses not to do so for a variety of reasons. To break coercion down further into its component parts, Schelling differentiates between deterrence and compellence. The difference between compellence and deterrence is the “difference between a threat intended to make an adversary do something and a threat intended to keep him from starting something.” Deterrence consists of influencing an adversary so that it does not act against a deterring nation (does not “start something”). Compellence consists of influencing an adversary that has already acted so that the adversary changes its behavior and ceases its action and, possibly also, reverses its actions (makes “an adversary do something”). Deterrence acts to prevent adversarial action; compellence acts to stop and reverse adversarial action.⁹ Coercion is akin to Clausewitz’s notion of real war, as opposed to “war on paper,” which is, or should be, driven by the state’s policy, among other things.¹⁰

What causes a nation to make such a choice? Typically, it is one of two reasons: the coerced nation concludes that it does not have the ability to oppose the coercing nation, or it concludes that it cannot afford the costs of continuing its opposition to the coercing nation. These two types of coercive strategies were discussed in 1959 by Glenn H. Snyder, in which he termed them denial and punishment, respectively.¹¹ Schelling also makes mention of the concept in his description of Secretary of Defense Robert S. McNamara’s “counterforce” and “cities” (later known as “countervalue”) strategies for nuclear war and deterrence.¹² Robert A. Pape discusses

these strategies using a mathematical construct in which the value of resisting a coercing nation, R , is expressed as an algebraic formulation.

$$R = B \cdot p(B) = C \cdot p(C)$$

Where R = value of resistance

B = potential benefits of resisting

$p(B)$ = probability of attaining benefits, B

C = potential costs of meeting

$P(C)$ = probability of incurring costs, C

When the value of R is less than zero, the resisting state finds it better (producing more value for itself) to succumb to the coercing state's demands. In this construct, a denial strategy decreases the probability of attaining benefits B (the value of $p(B)$), while a punishment strategy increases the costs of resisting (C) or increases the likelihood of incurring that cost, $p(C)$.¹³ These two strategies constitute two different means of achieving coercion. Not surprisingly, they are not collectively exhaustive; other theorists have suggested other mechanisms for forcing an adversary's behavior change. These can include decapitation strategies, or cutting off the decision-making portion of the opposing nation's army from the fighting portion, rendering it ineffective (possibly a variation of the denial strategy), and risk strategies, which focus more on manipulating the adversary's perceived probability of suffering costs ($p(C)$) rather than raising C itself.¹⁴ Likely there are others not discussed here.¹⁵

Intuitively, the notion of using coercion over brute force methods of force application is appealing to US national security. Brute force entails complete or near complete destruction of the adversary's ability to defeat US forces. Coercion, on the other hand, entails a seemingly more efficient use of force, one that does not necessarily need to destroy an adversary's armed forces but only to convince the adversary to change its behavior and policy. It would appear to be better for both sides, in terms of costs in capital and human life, if a resolution could be reached without complete destruction of one nation's military forces and its country. It also blends well with the US NSS, which advocates shaping the international environment with less destructive means than military force, such as diplomacy. The focus appears to be on achieving favorable end-states with minimal conflict. However, "because our shaping efforts alone cannot guarantee the international security environment we seek, the United States must be able to respond."¹⁶ Furthermore, coercion also does not exclude the brute force approach. The ability to coerce resides in a latent ability, an unused ability to inflict damage. As such, a coercive force and strategy that "fails" or does not convince the adversary to change its proposed or actual behavior, still maintains the capability to create a favorable outcome by brute force. We can think of this as graceful degradation.¹⁷

Additionally, there are essential elements of any coercion strategy, whether deterrence or compellence, denial or punishment.¹⁸ These are capability,

credibility, and communication, sometimes called the three Cs. Capability is the ability of the coercing state to attack either the adversary's ability to pursue its goals (denial) or things the adversary values, raising the costs of continuing its policy (punishment). This capability is very much like the capability required to engage in a brute force response to an adversary, but as Schelling emphasizes, in coercion, "[i]t is the *threat* of damage, or of more damage to come, that can make someone yield or comply," without having to completely destroy the adversary.¹⁹ A coercing state need not have the ability actually to carry out the brute-force action, but the adversary must believe it does.

This leads to the second essential element of coercion, credibility.²⁰ A coercing state must be able to threaten the adversary with the credible use of force for coercion to succeed. The adversary must believe the coercing state is willing to use force. Logically speaking, the adversary must be able to look at the equation above applied to the coercing state and determine that it is mathematically in the best interest of, or more valuable to, the coercing state to continue its action against the adversary. That is, the value R to the coercing state of resisting the actions of the adversary, or continuing to resist them, is greater than zero. When the adversary comes to this conclusion, credibility has been communicated.

This leads to the third essential element of coercion—communication. Before a nation attempts to coerce an adversary, it must make clear exactly why it is coercing that adversary; what is to be gained? Ideally, a coercing state should communicate an ultimatum to the adversary, describing what policies or behavior it finds offensive, with what policies or behavior they should be replaced, by when they should be replaced, and the consequences should they not be replaced. Each of these elements of communication exists in the ideal form of coercion; but in reality, they are sometimes ambiguous for a variety of reasons. Time limits may not be stated to allow for bureaucratic wrangling within the adversarial state. Consequences may not be stated explicitly so as to preclude an adversary from strengthening its defenses against attack, rendering the coercion less effective.

To be sure, there are other elements of successful coercion, but these often depend on the adversary. The adversary must be able to "do the math," so to speak, to determine the credibility of the threat. This could be described as the assumption of rationality. Indeed, we should always desire a rational opponent in a crisis, for rational men and women should be able to solve conflicts without resort to arms. Yet, even rational people can disagree. Rationality per se is not strictly required; the adversary must simply be able to calculate what is in its own best interests and perceive that the issue in question impacts an interest of the coercing nation. Along those lines, the level of interest in the conflict for the coercing state must be great enough, or must appear so to the adversary, to move that state to action. It is not irrational for the adversary to assume another state will not be moved to violence if the adversary pursues military objectives that are meaningless to the would-be coercer.

Completing the Framework

It should be apparent that Schelling's taxonomy has created another useful hierarchy for the application of military force. This is depicted in figure 6. Following decision analysis logic, each element is a fundamental objective. Each subobjective explains with increasing precision the objective above it. Furthermore, each objective is logically independent of the others. A nation employing military force may transition from deterring an adversary to compelling that adversary, but there is a distinct logical difference in the objective.

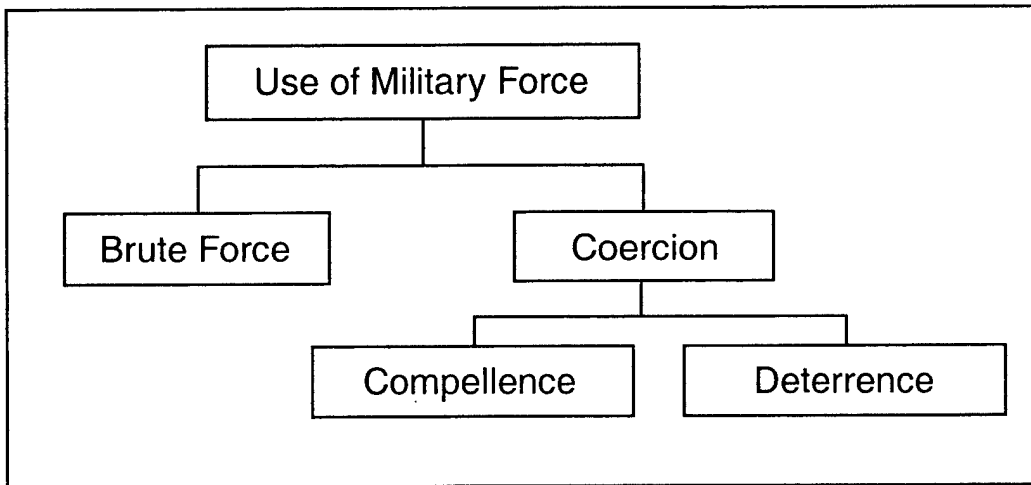

Figure 6. Schelling's Fundamental Objectives Hierarchy of Military Force

This may not be precisely true of the means of coercion, however. The means-objectives network is somewhat complicated. In general, the means of compellence and deterrence can be very similar. A coercing nation can execute a punishment strategy, a denial strategy, or some combination of the two to compel or to deter. These may be considered as part of a spectrum of strategies, with any particular strategy including elements of both, or even of another. Also, in practice, the distinction between punishment and denial is not always stark. (Nor is the distinction between brute force and some compellence strategies.) Destroying an oil refinery may prevent an adversary from conducting a prolonged campaign to seize territory. In a shorter conflict, however, that oil refinery may simply constitute a valuable component of the adversary's economy, one that makes no direct contribution to its ability to seize territory quickly. In this case, a denial strategy and a punishment strategy may influence one another, and each clearly influences the objective of coercion. Furthermore, these means are neither mutually exclusive nor collectively exhaustive, and, as such, form a poor basis for determining enduring requirements

for military strategy and acquisition policy. Clearly, the choice of a precise coercive strategy will be unique to a particular decision maker.

We can consider a different set of coercive "means," the three Cs. These clearly are a means to reach the objective of coercion, yet they are fundamentally different in nature from the strategies discussed above. Also, while there may be a trade-off between the three, with capability, for example, influencing credibility, they do not influence coercion so much as define elements for its successful accomplishment. Here we see a true case of a hybrid hierarchy. The three Cs act as both means and objectives, because each is a necessary element (although as a group not necessarily sufficient) to achieving effective coercion. Although the three Cs are not mutually exclusive nor collectively exhaustive, unlike the strategies discussed above, their existence is not subject to debate in an effective coercion strategy. That strategy must have each of these.

The three Cs, then, can form the basis for an enduring set of requirements for military strategy and acquisition in that they must be present in some fashion any time a nation seeks to coerce another nation. Any time one nation seeks to coerce another nation, it must have an appropriate capability to do so, it must present a credible threat to the adversary, and it must be able to communicate an ultimatum and perceive a response. The precise nature of the capability required, the basis for credible intervention, and the messages communicated to and from the adversary will be unique in each coercive situation. It is possible, however, to design a force and a strategy to deal with a broad set of coercive situations. This framework will help guide the development of those forces and strategy to give them the broadest utility possible.

There appears to be something missing from a hierarchy that uses elements such as these to assess strategy and force structure. Typically when alternatives are discussed and compared, they are compared against such measures as time and costs in dollars and lives. Presumably the more quickly an alternative can achieve a favorable outcome, the better that alternative is. If that alternative is also more expensive, then trade-offs must be made—plotting time required against dollars. These are the traditional measures of effectiveness for military policy alternatives. Capability, credibility, and communication, however, seem not to address these measures. Such measures as time, cost, and lives spared are important only insofar as they contribute to achieving a worthy goal. The cheapest alternative may rank highly in cost comparison with other alternatives, but if it does not contribute to the overarching goal, it is valueless. That is the essence of decision analysis: creating a logically consistent basis for deriving alternatives and assessing their value. Any alternative is valuable only if it contributes to the overarching goal, and the search for inexpensive and rapid means to achieve that goal should never lose sight of this. It never will if the decision-analysis framework is used. The next chapter will discuss precisely how these traditional measures are incorporated into this framework.

When the utility of the decision-analysis framework is established, it is left to show its relevance to the current strategic context. How do we transition between *NSS/NMS* hierarchy and the coercion theory hierarchy? We must attach the "Use of Military Force" objective to one of the subobjectives in the *NSS/NMS* hierarchy. The most obvious connection, especially in this context, is using military force to respond to threats to security, in either an MTW scenario or a small-scale contingency. Either of these is likely to require military force to resolve, and both are candidates for coercion over brute force measures. To avoid specification, we can attach it directly to the "Respond" objective, as a means objective for any of the lower-level scenarios. This also complements the *NSS*, which calls for using "the most appropriate tool or combination of tools—diplomacy, public diplomacy, economic measures, law enforcement, military operations, and others."²¹ In this context, the objective of using military force is simply one of several means to achieve the "Respond" objective. The completed hierarchy is shown in figure 7.²²

The United States will always need the ability to call on military force to respond to threats to its national interests. As the presidential administration changes, we can expect the *NSS* to change. This change may or may not be significant. With its worldwide interests, however, it is reasonable to expect that the United States will need to be able to employ force in a coercive scenario regardless of the text of the next national security strategy document. As the new administration investigates investments in the military, it should do so with the enduring requirements of

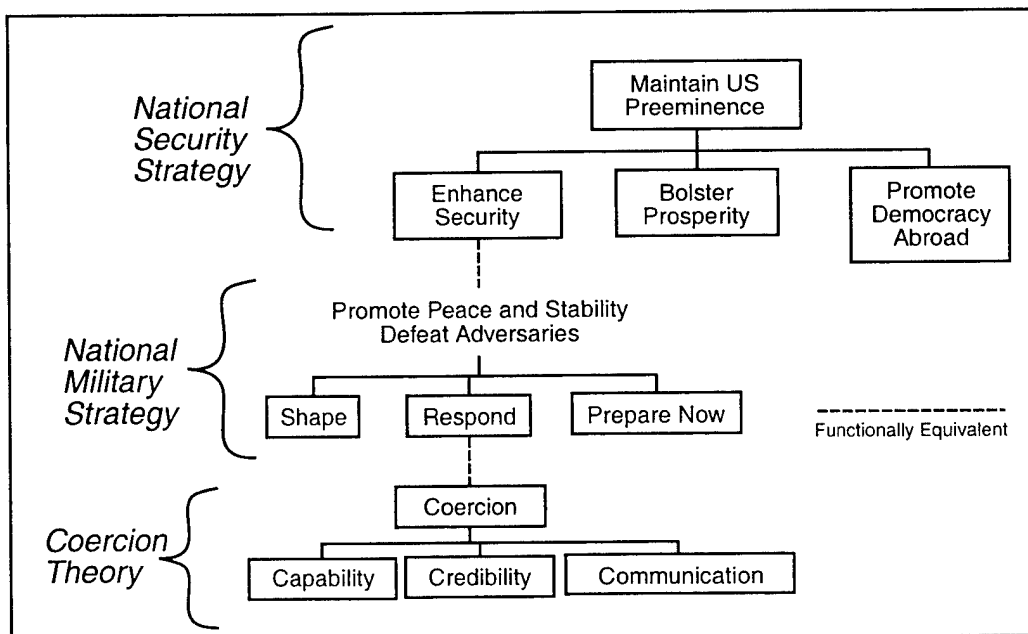

Figure 7. Completed Hybrid Hierarchy

such strategies in mind. The three Cs provide such a set of enduring requirements for military forces and strategies.

Is the hierarchy complete? Yes and no. It is an aid to focusing the decision-making process, with three components identified that must always be present. It has a sound basis, built upon decades of academic research and scores of cases. It has an enduring quality, as the United States will likely always need an ability to respond to an adversary no matter the nature of the nation's or the military's leadership. However, the hierarchy is not confined, strictly speaking, to the use of military force. Some of the enduring requirements of coercion cannot be fulfilled by military force alone, but must be enhanced by diplomatic means—especially the requirement for communication. That indicates that there exist holes in the hierarchy, due somewhat to its hybrid nature. There are other means by which to respond to national security threats, some of which the nation has yet to discover. That, however, is not a shortcoming of the decision analysis framework, but a strength, as is the identification of holes in the logic. The ability of military force to cover adequately all the requirements of a coercion strategy is debatable; the necessity of their coverage is not. If military force cannot account for each of the three fundamental requirements of coercion, some other means must be found if coercion is to be effective. That should always be kept in mind as the nation creates coercion strategies and builds military force structures to support them. When the nation builds a strategy or buys a weapon system, it must identify what objective need(s) it satisfies and what is yet unsatisfied. Only by constantly referencing the complete requirement can efficacious strategies and force structures be obtained.

Defining a Specific Context

The decision analysis framework is now nearly complete. Referring back to figure 1, we must still define a specific decision context, one even more specific than the need for coercion, but one general enough to provide utility in a wide range of scenarios. The generation of scenarios has been one of the most important endeavors in any strategy review process, one that constantly vexes the study designers. The problem is one of predicting the future, especially since that future itself likely will be affected by the results of the review in a Schrödinger-like fashion.²³ As we base future strategic decisions on theories we already know and to some extent on force structure we already have, it is not unreasonable to base future scenarios on those we already know, especially since we have nearly 2,500 years of historical accounts of the types of scenarios that may require the application of military force. The focus of this study will be on what can be called third party coercion or US intervention on behalf of a friendly nation that is under military attack by an adversary. In this situation, the United States will act as the coercing nation, the adversary will be the coerced nation, and the friendly nation will be the ally. This is the very situation that

has existed for a number of major conflicts over the past century. These conflicts included World Wars I and II, Korea, Vietnam, and Iraq. Indeed, this type of power projection scenario in support of an ally is the most likely scenario for the next 25 years, according to the QDR 2001 Working Group: "the majority of America's military will be required to remain organized to conduct power projection operations during regional conflicts, a posture conceptually similar to today."²⁴

To clarify further, this study will classify the adversary as rational enough to perform the calculations discussed previously, but irrational or imperceptive enough to have ignored any previous efforts at deterrence that might have taken place. It will also classify the adversary as somewhat risk seeking in behavior, willing to jeopardize men and equipment for limited gains. This assumption is something of a worst case assumption as this kind of adversary may not be susceptible to pure strategies of denial or punishment. This analysis will largely and purposely avoid discussions of the mechanism of coercion, a subject that has been treated with some success in other works.²⁵ It is enough to know that, based on historical evidence, adversary nations have been coerced into capitulation while still retaining an ability to continue violence, either due to a denial strategy or a punishment strategy, or some hybrid or other type of strategy. Finally, we will assume that the friendly nation in this scenario is willing to have the United States intervene on its behalf. This may or may not include basing forces on its soil. This point will be discussed further in the next chapter.

Now we have the strategic and specific context, a hierarchy with a means network that identifies enduring requirements for military force in the strategic context and a specific context. This should get us "much closer to what we want." Using this framework, this study will examine the alternative means to achieving the objective of coercion, emphasizing the contribution of airpower assets to a coercion strategy. The next chapter will focus in depth on each essential element of coercion, discussing what airpower assets can provide, how they can provide it, and what gaps they leave open in a coercion strategy.

Notes

1. Much of the following discussion derives from Ralph L. Keeney, *Value-Focused Thinking: A Path to Creative Decisionmaking* (Cambridge, Mass.: Harvard University Press, 1992), especially the preface and chapters 1-3. Although many other texts on decision analysis exist—notably Howard Raiffa, *Decision Analysis* (Reading, Mass.: Addison-Wesley, 1986) and Detlov von Winterfeldt and William Edwards, *Decision Analysis and Behavioral Research* (Cambridge, Mass.: Cambridge University Press, 1986)—Keeney provides a single-volume reference for the interested reader that can be read and understood without prior knowledge of decision analysis or rigorous mathematics. Additionally, Keeney provides scores of real-world examples to elucidate his concepts. Sadly, none of them considers the topic in question.

2. Keeney refers to this structure as a "means-ends objectives network." The terminology in this study is used to aid in separating the two concepts.

3. It must be noted that the most recent edition—December 1999—*A National Security Strategy for a New Century* was produced by the Clinton administration, and it incorpo-

rates much of the institutional culture of that administration developed over the previous seven years, including lessons from the past four strategy reviews. Presumably, the Bush administration will produce its own NSS in due time. Until then, however, this will be the guiding influence on strategy development and acquisition, as well as the 2001 Quadrennial Defense Review. Fortunately, for those seeking lasting guidance, many of the objectives in this document are of such a strategically high level as to be almost universally acceptable. Indeed, the objectives appear to flow almost directly from the Declaration of Independence, when that document states that we have "certain unalienable Rights, that among these are Life, Liberty and the pursuit of Happiness." Hereafter cited as NSS.

4. NSS, iii.

5. *Ibid.*, 5.

6. Thomas C. Schelling, *Arms and Influence* (New Haven, Conn.: Yale University Press, 1966). Also, see Glenn H. Snyder, *Deterrence and Defense* (Princeton, N.J.: Princeton University Press, 1961).

7. Schelling, 2.

8. Carl von Clausewitz, *On War*, ed. and trans. by Michael Howard and Peter Paret (Princeton, N.J.: Princeton University Press, 1976), bk. 1, chap. 1, esp. 75-77.

9. Schelling, 70-72.

10. Clausewitz, 87.

11. Glenn H. Snyder, *Deterrence by Punishment and Denial*, Research Monograph No. 1 (Princeton, N.J.: Princeton University Press, 1959).

12. Schelling, 192-98.

13. Robert A. Pape, *Bombing to Win: Airpower and Coercion to War* (Ithaca, N.Y.: Cornell University Press, 1996), 16-18. This equation is Pape's mathematical formulation for coercive resistance. Strictly speaking, Pape's consideration of "coercion" is actually an account of what Schelling describes as "compellence." For the purposes of this study, Schelling's taxonomy will be used. For illustrative purposes, however, Pape's logical construct applies equally well in discussions of compellence and deterrence (i.e., Schelling's "coercion").

14. Pape and Schelling both discuss the manipulation of risk as a strategy for coercion. Pape explicitly describes it as "rais[ing] the probability of civilian damage." (Pape, 18.) Warden is perhaps the most vociferous advocate of the decapitation strategy. See John A. Warden III, "Employing Air Power in the Twenty-first Century," in *The Future of Air Power in the Aftermath of the Gulf War*, ed. by Richard H. Shultz Jr., and Robert L. Pfaltzgraff Jr. (Maxwell AFB, Ala.: Air University Press, 1992), 57-82.

15. It should be noted that there is considerable debate within the academic community over the relative efficacy of punishment strategies over denial strategies, and if decapitation strategies even work at all or as a subset of the other two. Much of this debate stems from the publication of Pape's book. In it, he argues that "strategic bombing does not work." His justification of this is that punishment strategies are largely ineffectual, and strategic bombing is used to prosecute a punishment strategy. Although his definitions of strategic bombing and punishment strategies are arguable, the contribution of the debate to the development of coercion theory is not. This study will not engage in the debate, especially after much of the dust has already settled. Suffice it to say that if a punishment strategy exists as a logically viable strategy, and there is any proof that it has proven of value in a real-world military campaign, it remains a possible strategy for the would-be coercer. For a review of debate, see Barry D. Watts, "Ignoring Reality: Problems of Theory and Evidence in Security Studies," *Security Studies*, Winter 1997-1998; Mark Conversino, "The Changed Nature of Strategic Air Attack," *Parameters*, Winter 1997-1998; Robert A. Pape, "The Air Force Strikes Back: A Reply to Barry Watts and John Warden," *Security Studies*, Winter 1997-1998, 191-214; and Karl P. Mueller, "Strategies of Coercion: Denial, Punishment, and the Future of Air Power," *Security Studies*, Spring 1998, 182-228.

16. NSS, 14.

17. For possibly the most concise discussion of coercion and its positive attributes, see Karl P. Mueller, "Coercion and Air Power: A Primer for the Military Strategist," in *Readings Vol. IV: Strategic Airpower and National Security*, SAAS 632 (Maxwell AFB, Ala.: School of Advanced Airpower Studies Class Text, Academic Year 2000-2001), 1-13. (Hereafter cited to as Mueller, *Primer*.) For a longer treatment, see Mueller's contribution to the debate on Pape's *Bombing to Win* in Mueller, 1998.

18. See Mueller, *Primer*, 6-8, for a concise description of these "requirements of coercion."

19. Schelling, 3.

20. The foundational discussion of credibility and its nuances can be found in Schelling.

21. *NSS*, 14.

22. Strictly speaking, it is not complete. There are other means, besides military force, by which to respond. Furthermore, the hierarchy does not address the other *NSS* objectives, Bolstering Prosperity and Promoting Democracy Abroad. For the purposes of guiding military strategy, however, we can consider the hierarchy functionally complete.

23. In 1935, physicist Erwin Schrödinger wrote an essay attempting to demonstrate the quantum theory of superposition, which basically posits that, on a subatomic level, matter can exist in two forms simultaneously. Schrödinger described a cat in a sealed lead box into which had been dropped a vial of cyanide. It is possible for the cat to break open the vial, in which case it will die. It is not a certainty there exists some probability less than one that the cat will open the vial. Therefore, one cannot say with certainty that the cat is alive or dead. The cat, however, does not exist as both a live cat and a dead cat simultaneously. It is one or the other. By looking within the box, an observer can tell precisely which cat exists. At a quantum level, however, particles do exist in separate states simultaneously. The reference here is to the fact that the actions the United States takes with regard to its own defense structure are akin to looking inside that box. While probable threats exist, and, like quantum particles, exist simultaneously, the actions the United States takes can themselves determine which threats become realities.

24. Sam J. Tangredi, *All Possible Wars? Toward a Consensus View of the Future Security Environment, 2001-2025*, McNair Paper 63 (Washington, D.C.: Institute for National Strategic Studies, National Defense University, 2000), 136.

25. For a discussion on the use of both types of strategies to coerce an opponent, see Daniel L. Byman, Matthew C. Waxman, and Eric Larson, *Air Power as a Coercive Instrument* (Santa Monica, Calif.: RAND, 1999). For a discussion of coercion mechanisms, see Thomas P. Ehrhard, *Making the Connection: An Air Strategy Analysis Framework* (Maxwell AFB, Ala.: Air University Press, 1996).

Chapter 3

Assessing the Contributions of Airpower to a Coercion Strategy

Coercion depends more on the threat of what is yet to come than on damage already done. The pace of diplomacy, not the pace of battle, would govern the action; and while diplomacy may not require that it go slowly, it does require that an impressive unspent capacity for damage be kept in reserve.

—Thomas C. Schelling
Arms and Influence

The use of military force is fundamentally tied to policy. As it was true in Schelling's time, so it is true today. However, technological developments may not often be pursued with regard to the same policy. When they play a part in military strategy, they should be. Technology will change the ability of the military to carry out the objectives of policy. As enemies present new challenges, technologies will present new solutions. Military strategy must incorporate those technological solutions coherently to support national strategy. As discussed in the previous chapter, as long as the nation needs to employ force to coerce an adversary, it must be prepared to build and enforce a strategy with at least three essential components: capability, credibility, and a means of communication. The technological solutions and the platforms that effect a coercive strategy must support these components of coercion. This chapter explores how armed forces, especially airpower, can contribute to those essential components to produce "an impressive unspent capacity for damage" and a coherent coercion strategy.

Capabilities, Qualities, and Characteristics

The components of coercion are capability, credibility, and communication. A coercive capability is essentially an ability to apply force against an adversary. Credibility is a combination of legitimacy and believability associated with the coercing state's actions. Communication refers to the ultimata that a coercing state makes to an adversary. This study argues that any coercive strategy requires each of these, in perhaps varying quantities depending on the coercive context, but no coercive strategy is complete without all of them.

It should stand to reason, then, that the tools used to effect coercion must be consistent with the coercive strategy chosen. That is, they should not subtract from such a strategy's capability, credibility, and communication; they should directly contribute to it. Consider the following notional

example of two states, Ayland and Beeland, in a parched region of the world. Suppose Beeland invades Ayland's agricultural region in a campaign of territorial expansion. Not wanting to cede valuable territory to the adversary, Ayland's ambassador to Beeland responds with an ultimatum: Cease your invasion, Beeland, and call your troops back. If you do not immediately return all the seized land to the sovereign government of Ayland, we will bring to bear the full force of our great national water pistol against you and your forces. How does this attempt at coercion fare with respect to the three Cs?

Certainly an ultimatum has been communicated, with one person speaking for the nation of Ayland. However, Ayland's tool of coercion, the national water pistol, provides neither a capability to coerce nor a credible threat. Suppose the national water pistol can deliver a great volume of water precisely where needed in the short length of time it takes to aim, point, shoot, and have the water traverse the distance to the target. This unique capability of the water pistol does not provide a capability to effect any coercive strategy, whether it is punishment, denial, or a combination of the two. A stream of water cannot threaten the water-resistant forces of Beeland, and the free delivery of water to the dry lands of Beeland would be a reward, rather than a punishment. Furthermore, the threat is simply not credible. Why would Ayland shoot its valuable water toward Beeland and its forces? Such a move would not change Beeland's strategic calculus (there is no increased cost or reduced benefit) and it only serves to bring disadvantage to Ayland by reducing its water supply.

This example makes the point that the elements of force a nation uses to effect a coercive strategy have unique capabilities, qualities, and characteristics that may or may not enhance their value to a chosen strategy of coercion. In an unfortunate circumstance of the English language, however, two words in this example have decidedly different meanings. The first C of coercion is capability or, more precisely, the capability to deliver force against an adversary. Any unique element of the force structure used in a coercive strategy has its own unique capabilities that describe its function and utility on the battlefield. The unique *capability* of that force element, however, does *not* necessarily correspond directly to *coercive capability*. For instance, a platform such as the national water pistol may be incredibly easy to use. That capability has no relation, as shown above, to the capability to coerce. In some other scenario, this ease-of-use *capability* may increase the *credibility* of a coercive strategy because it could easily be used against an adversary (perhaps one using forces that are not water resistant). In this scenario, however, this capability contributes nothing to coercive capability, credibility, or communication.

We can use this type of analysis on any element of a force structure that executes a coercive strategy. By assessing the unique capabilities, qualities, and characteristics of any element of force structure used in a coercive strategy in the type of scenario discussed in this study, we can determine how

that element helps effect that strategy. Before doing so, however, we must more fully investigate the three Cs to facilitate such an assessment.

The last chapter proclaimed the framework nearly complete. Indeed, at an aggregated level, it is complete. There is an obvious mismatch, however, between the three components of coercion and the contributions of individual platforms used in the coercive strategy. Coercion is fundamentally a political effect; the tools of coercion essentially function at a much lower, tactical level. There must be a direct relationship between the political goals and the tactical actions used to achieve them. Translating between the two realms of action, political and tactical, is the challenge.

While coercion itself resides at the political level of war, the components of coercion inhabit a lower, strategic level of war. That is, the three Cs combine to make up a strategy to effect coercion. The following discussion will review the theoretical basis for each of the three Cs, and it will draw from that basis the operational-level effects required to achieve each of the strategic-level components of coercion. At the end of the discussion of each component of coercion, we will have developed a means-end network for each component that lists the operational-level subcomponents of coercion peculiar to that component.

Although at that point the framework will be more nearly complete, without discussing the tactical requirements of coercion in this scenario, it is difficult to assess the tactical contributions of each tool of coercion. Due to the complex nature of interactions between the levels of war and between effects at the tactical level, such a discussion would soon prove intractable and counterproductive. The framework presented in this chapter, developed to the operational level, represents an appropriate combination of simplicity and explanatory value for this study. Chapter 4 will discuss specific elements of the force structure that execute a strategy of coercion at an operational level. It will consider the operational contributions of force-structure elements to a strategy of coercion that correspond directly to the means-end networks that will be developed in this chapter. As we develop the framework in this chapter, however, keep in mind the compromise required between explanatory value and tractability.

Finally, before investigating each of the components of coercion more fully, it bears repeating that this study is fundamentally concerned with the strategy and hardware of coercion. The concepts of coercion are well established; this study does not introduce any new concepts into the discussion. However, it does translate the conceptual nature of coercion to a more tangible nature, connecting the theoretical requirements of coercion to hardware requirements. Using these coercion concepts, it develops measures of merit to show more precisely how military hardware can help achieve coercion. In doing so, it blends the well-established taxonomy of coercion with the well-established taxonomy of military means. As the two concepts developed separately, there are undoubtedly shared ideas and meanings; but there are also contradictory ideas and meanings. As much as possible, this study will attempt to remain true to both schools of

thought. Where conflicts occur, this study will attempt to paint the intended ideas clearly and to introduce clarifying language. Furthermore, since this study primarily deals with the military strategy and hardware of coercion, it does not consider many fundamental notions of coercion theory. Indeed, there are many elements of coercion that have no military equivalent and to which military force cannot contribute. This study does not refer to such fundamental concepts as legitimacy; they are primarily political concepts, handled at a level above the strategic level of war. They are no less critical to achieving coercion, but they require an expertise beyond what the military can provide.

The discussion that follows will consider each component of coercion: Capability, Credibility, and Communication, individually. Each discussion begins with a review of the theoretical underpinning of the component, and then considers the practical aspects of achieving the strategic effect. As a first step towards clarity, when referring to each of the three Cs, the name of each component will be capitalized. That is, Capability, as a component of coercion, is not to be confused with a generic capability that may contribute to any of the three Cs or none at all.

Capability

Capability is the ability to bring force to bear against an adversary. The goal of a coercive strategy is to apply just enough force to cause the adversary to change its behavior, ceasing its current actions and beginning new behaviors as appropriate. The mechanism by which a behavior change takes place can be complicated; sometimes it is beyond explanation. It is also likely to depend on the nature and culture of the adversary.¹ Multiple mechanisms exist to effect a behavior change. Pape has argued that, generally, punishment strategies are ineffective; only denial strategies have the opportunity for success.² Warden has argued that decapitation strategies are the most decisive means of coercion.³ Still others have argued that an effective strategy includes a combination of mechanisms to ensure coercion, based on the context of the situation.⁴ It is not the point of this study to argue the relative efficacy of possible strategies. The selection of a specific strategy of coercion will inevitably be the responsibility of national leadership in the event and that body will likely choose based on a host of factors including the nature of the enemy and the level of US interest involved, available intelligence on the enemy, and personal preference. Additionally, and of import to this study, available capability can dictate available coercion strategies to the theater commander and to the coercing nation.

Schelling summed up the essence of the capability to coerce an adversary: "It is the *threat* of damage, or of more damage to come, that can make someone yield or comply" (emphasis in original).⁵ Capability includes not only an ability to inflict damage but also a reserve capacity to inflict more damage. To be effective, this should include not only an initial capability

but also a protected capability that the adversary cannot compromise. Coercion, however, is a multiplayer game; while the coercer attempts to coerce the adversary, a reasonable adversary will fight back by engaging in a coercion strategy of its own (countercoercion), attempting to coerce the coercer into changing its behavior so the coercer no longer threatens the adversary. Consequently, the mechanisms available to the adversary may be the same mechanisms available to the coercer.

Therefore, we must consider capability from two perspectives: offense and defense. Offensive capability constitutes the ability to inflict damage. Defensive capability protects the offensive capability so that there is a possibility of more damage to come. While these elements differ conceptually, they rarely are separate in reality. Offensive and defensive capabilities are often contained on the same platform, making the platform less vulnerable and thus reusable in a hostile situation. Some platforms, however, may be purely offensive—or may only provide defense for other platforms as their only contribution—so the framework must also allow for such contributions. We will therefore keep the conceptual discussion of offense and defense separate.

Offensive capability is the ability to target the adversary, bringing sufficient force to bear in a way that will change its behavior. Theoretically, it is difficult to assess this capability without considering specific coercive mechanisms. Practically, however, the offensive capability that is useful for pursuing a denial strategy is largely also useful for pursuing other types of strategies; and applications of offensive capability can support both denial and punishment strategies.⁶ Ultimately, the greater and more flexible the offensive capability the more strategic options for coercion a commander has.

To bring offensive force to bear, a coercing nation must be able to find targets, to attack targets, and to assess the impact of those attacks. The ability to find a target includes several subordinate tasks that act like a funnel, focusing the coercer's abilities to the precise points of impact on which its military capability can create the desired effect, physical or otherwise. At the top of this funnel is the ability to comprehend the adversary as a targetable entity. This means understanding what the adversary is doing, and how and why it is doing it. If a coercer can understand the adversary's strategy and what it holds valuable, it can define eligible targets. This level of analysis of the enemy leads the coercer to decide on a precise mechanism for coercion, taking into account the vulnerabilities of the adversary and its strategy. Once the coercer has defined these vulnerabilities, it must be able to locate targets for attack. This includes the types and locations of targets that will have not only the desired tactical effect but will lead to desired effects at higher levels and, ultimately, the desired political outcome. A coercing force must then locate precise targetable elements of the target sets, or desired mean points of impact. This includes accurate coordinates that, when attacked, will have the desired effect on the target system.⁷

Next, the coercer must be able to attack the target. This requires not only knowing where a target is but also tracking that target until the coercer strikes it and achieves the effect.⁸ This is the ability to bring force to bear directly on the desired impact point. The coercer must communicate the target information to the attacking platform. The attacking platform then must deliver its payload precisely on the target and render the desired effect.

After the adversary has been attacked, the coercer must assess the effect of that attack. The coercer must measure the effect in several dimensions. Did the attack hit the intended target? Did the attack render the desired tactical effect? Did the tactical effect achieve the desired operational effect? This is essentially the reverse of the funnel outlined above, in which the coercer compares the desired mechanism of affecting the target to the actual outcome.

Do not let the nomenclature hide the concept above. An individual platform necessarily acts at a tactical level of war. A platform type or system, however, provides an operational capability. In this case, the coercer needs an operational capability to assess both the tactical-level effect of an attack and the operational-level effect. The framework is disaggregated only to the operational level, but this level requires an ability to assess tactical level effects. This nexus between operational requirements and operational capability is where the framework and the analysis of force structure meet.⁹ (For a demonstration of this nexus, see chap. 4.)

The other side of Capability is defense. The coercer must protect its existence, maintaining the ability to apply *more* coercive force and therefore threatening greater costs or greater reduction to the adversary's means of aggression. There are three types of defensive capability: self-protection, system protection, and total force protection. An individual system can carry its own means of defense, or self-protection. These means can include not only onboard means but also design features (such as speed or altitude limits) that make the platform less vulnerable to attack. A platform can also have operating characteristics that help protect the platform's operational system. This might include a hardened control cell that can withstand attack and still effectively operate or direct the platform. Finally, one platform can protect other platforms executing the coercive strategy. This symbiotic total force protection may be that platform's only contribution to a coercive strategy.

Force element numbers are the final subcomponent of Capability. Significant numbers of coercing platforms provide a commander with multiple opportunities to achieve coercive effects. Greater numbers can provide an increased offensive capability and an increased defensive capability. On the one hand, more platforms means more adversary targets can be held at risk, and, presumably, the total coercive effect can be achieved sooner. On the other hand, more platforms means a coercer can suffer more attrition while still maintaining an ability to deliver force. Presumably, more is always better when executing a coercion strategy. There is

no absolute number, however, nor an intrinsic minimum. Recall that the goal of coercion is the efficient application of force. As a minimum, numbers of force elements must be adequate to achieve the desired coercive effect in the desired time.

The Completed Capability-Means Network is shown in figure 8. This tree structure includes the complete list, as discussed above, of the means by which coercion capability is achieved. We will use this in the following chapter to compare the contributions of different platforms to a coercion strategy.

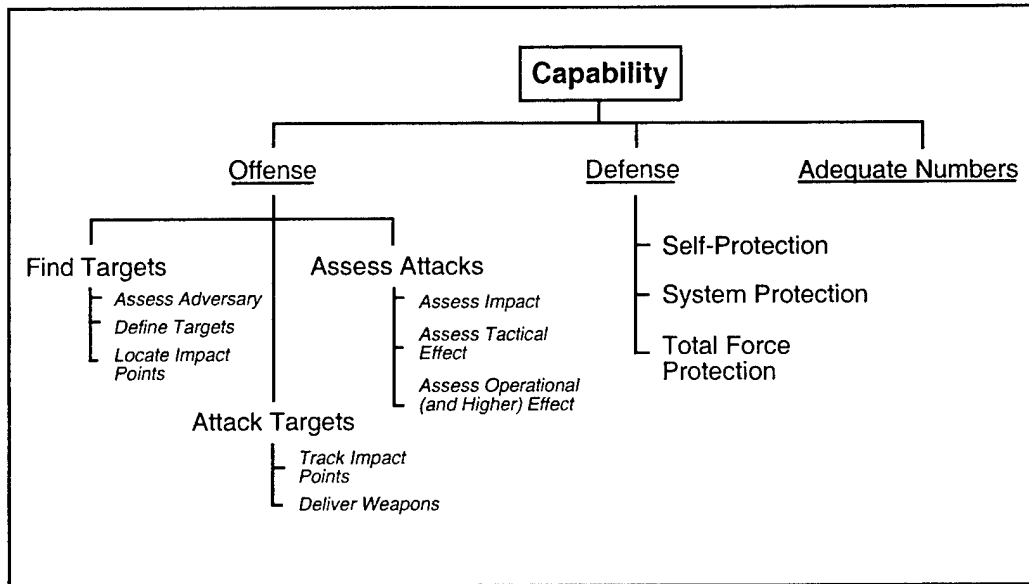

Figure 8. Completed Capability-Means Network

This consideration of capability notwithstanding, however, an adversary still may not be coerced even though it realizes it can no longer reach its objective against the coercing nation's capability (assuming the coercer pursues a denial strategy). It must *believe* not only that it cannot reach its objective but also that it cannot effectively coerce the coercing nation by either denying it its strategy by inflicting enough cost on the coercer to dissuade the coercer from carrying out its strategy. Punishment as a countercoercive strategy may be more likely, since an adversary might not have the power to defeat a coercing nation's military forces directly, but it may have the ability to charge great costs in lives to the coercing nation, more than the coercing nation is willing to pay. It may do this, additionally, when all else seems lost.¹⁰ For this reason, not only must the coercer have the means to protect against prohibitive (coercive) losses, a coercer must have the will to play the two-player coercive game until its end. That is the essence of credibility.

Credibility

As he did with Capability, Schelling also offers us insight into the nature of Credibility: "It is a paradox of deterrence that in threatening to hurt somebody if he misbehaves, it need not make a critical difference how much it would hurt you too—if you can make him believe the threat" (emphasis in original).¹¹ As it applies to deterrence, so it also applies to coercion in general. The coercing party must convince the adversary that it will continue coercive action until its demands are met. For coercion to be successful, the adversary must believe it is to the coercer's advantage to continue coercion. This advantage includes returns that are proportional to the level of effort the coercer expends and costs that are proportional to the returns.

Pape's algebraic formulation is essentially a cost-benefit analysis in which the "benefits side" of the equation includes $p(B) \cdot B$ and the "cost side" includes $p(C) \cdot C$. The mathematical result that Pape fashions with this equation is simply the net value of the benefit side minus the cost side. As it applies to the adversary, when the coercer analyzes its strategic options, so it applies to the coercer when the adversary analyzes its countercoercive strategic options. While the coercer tries to increase the value of coercion, the adversary tries to increase the value of resistance.

Algebraically, we can represent the equations for each of the opposing parties in a coercive conflict as shown in the equation below. This modified form of Pape's equation is interpreted for both sides in coercive conflict.

$$V_c = B_c \cdot p(B_c) - C_c \cdot p(C_c)$$

$$V_R = B_R \cdot p(B_R) - C_R \cdot p(C_R)$$

Where V_c = value of coercion

B_c = potential benefits of coercion

$P(B_c)$ = probability of attaining benefits of coercion

C_c = potential costs of coercion

$P(C_c)$ = probability of incurring costs of coercion

And V_R = value of resistance

B_R = potential benefits of resistance

$p(B_R)$ = probability of attaining benefits of resistance

C_R = potential costs of resistance

$P(C_c)$ = probability of incurring costs of resistance

Complicating this analysis is the fact that the calculus of one equation is dependent on the calculus of the other equation, especially in the case of the coercer. Specifically, the benefit to the coercer is, in part, a function of the result of the cost-benefit analysis performed regarding the adversary. If the coercer can increase the cost side of the adversary's equation, or if it can decrease the "benefit side" of that equation, the benefit side of the

coercer's equation is likely to increase. Correspondingly, the benefit to the adversary is related to its ability to either decrease the coercer's benefit side, increase the coercer's cost side, or both.¹²

We can express this relationship between the two equations as shown in the equation below. Interaction between the two equations ("∞" means "is a function of").

$$B_C \propto \frac{1}{R} = \frac{1}{B_R \cdot p(B_R) - C_R \cdot p(C_R)}$$

$$\text{And } B_R \propto \frac{1}{C} = \frac{1}{B_C \cdot p(B_C) - C_C \cdot p(C_C)}$$

As shown here, while the coercer is attempting to reduce the value of V_R , the adversary is simultaneously attempting to reduce the value of V_C . Mathematically speaking, this presents an open-form solution with complex interactions. While difficult to solve, it may not be intractable given enough prior information (or credible assumptions) on the variables involved. Speaking in terms of real-world human interaction and conflict, however, the problem quickly becomes unsolvable due to the varying nature of individual and aggregate human reactions and the inevitable fog of war that surrounds any conflict, thus hiding the true value of some of the critical variables. This interactive, even game-theoretic, nature of coercion ensures that there are no easy analytical solutions for finding the right mix of forces to apply or strategies to pursue. This is perhaps the basis for the complex and nonlinear puzzle that has baffled strategists for years. Indeed, mathematical representations such as these offer little in the way of quantitative clarity and even less hope for a mathematically rigorous solution for even a well-defined, well-established, and unvarying case. Add the goal of finding an enduring solution or set of solutions against a vaguely defined adversary and the situation soon appears even less appealing. There will likely always be a solution and even more likely several solutions, but it is beyond the capability of the mathematician to find it or them. The mathematical representation, however, can highlight the complex nature of the task, and it can at least point to the critical interactions that a coercive strategy must consider.

While the coercer seeks to drive $V_R \leq 0$, the adversary seeks to drive $V_C \leq 0$ as well to coerce the coercer to quit its strategy. Both coercer and adversary are also operating against a time limit: the length of time required for the adversary to achieve its desired gains. If the coercer cannot act until after the adversary has achieved its goal, coercion may be much more difficult and costly, especially if the adversary is in a position to deny the coercer the inherent value of the objective on the adversary's retreat. The adversary will not be coerced until it perceives two conditions: the

value of resistance, V_R , must be zero or negative, or obviously moving towards a negative value; and the coercer's value of coercion, V_C , remains positive and cannot foreseeably be made negative by the adversary's (or any other party's) efforts. These two conditions, from the coercer's viewpoint, constitute the mathematical presentations of the two subcomponents of Credibility: feasibility and intent. The adversary must believe that the coercer *can* implement the coercive strategy effectively (reduce V_R to a value less than zero), and it must also believe that the coercer *intends* to implement that strategy until its desired end-state is achieved (will maintain a positive value for V_C by either valuing the potential benefits of coercion so highly or valuing the costs so minimally that it cannot be countercoerced).¹³

Feasibility includes a combination of the appropriate coercive force applied in time to achieve suitable effects for coercion against a particular adversary. Specific elements that add to feasibility include the proper escalatory force, adequate force in an employable position in time to have a coercive impact, and a proven force for the context. A proper escalatory force gives the coercer the ability to escalate the level of conflict above that which the adversary is willing or able to match. Often simply the intervention of a third-party coercer represents escalation, raising the scale and scope of the conflict. A coercer achieves escalation dominance when it introduces enough force to achieve coercion while denying the adversary the ability to introduce enough force to achieve countercoercion. A proper escalatory force is that required to achieve escalation dominance.¹⁴

The second element of feasibility is timely force employment. If the coercer's force, highly capable though it may be, is not deployed to the theater in time to have a coercive effect before the adversary achieves its objectives, the coercer's threats are not credible. The coercer must be able to recognize a conflict requiring coercive measures, deploy force to within attacking range of the adversary's potential targets, and employ that force in a coercive manner. More than most, this measure offers a good point of comparison between different strategies and force packages and different force elements. The sooner a coercive force can deploy to a region, the better suited it is to a coercive strategy.¹⁵

Finally, a proven force for the conflict is possibly the most contextually sensitive measure in this framework. The force must not only be capable of delivering the effects the coercer desires but the adversary must also recognize that this force is capable, it must be proven to the adversary. A force may prove itself well before a coercive scenario in another conflict or in the early stages of the current scenario. Until the force is proven to the adversary, however, it will not be coerced. The clearest example of an adversary not perceiving a proven force is Iraqi president Saddam Hussein. Before Desert Storm, he refused to believe the United States could be successful with airpower. It is not enough that the coercer believes airpower can be decisive the adversary must believe it as well.¹⁶

Actions that show the adversary that the coercer is not likely to withdraw force until it achieves coercion are the basis for credible intent. In the United States, political will demonstrates this intent. Political constraints on the use of coercive force are the best indicators of political will. Although political constraints as a whole are unique to each coercive scenario, US forces and those of most Western nations are typically subject to some enduring constraints. These constraints include, but are not limited to

- rules of engagement that limit the use of force,
- use of the least vulnerable force elements, even when not the most appropriate, and
- minimization of casualties, both friendly and adversary.¹⁷

Some force elements and platforms have acquired reputations that tend to prevent their use in limited conflict, and political leadership may dictate restrictive rules of engagement. Such was the case in Vietnam with the B-52 Stratofortress, a nuclear weapons platform that was thought to send the wrong message to the Vietnamese.¹⁸ Political restrictions can also limit the use of expensive force elements when interest in the conflict is limited, although this line between cost and restrictions on use has begun to blur in recent years.¹⁹ Probably this is due to the rising emphasis on minimizing losses. With arguable interests in a conflict, the United States is less likely to accept significant equipment losses and casualties to effect coercion. An ability to minimize casualties increases a platform's value in a coercive strategy. Similarly, a platform with increased survivability, even if it has limited Capability, may have more Credibility value than a platform with more Capability and less survivability.

A final word is in order on Credibility and coalitions. Increasingly, the United States and other nations seek to engage in conflict only with the support of other like-minded nations. Such coalitions bring their own restrictions, as demonstrated by Operation Allied Force, which depended on the North Atlantic Treaty Organization coalition for success but was hampered by the allied constraints on target selection in and around Serbia.²⁰ This, again, is a contextual element that is important to consider when developing a specific coercion strategy, but it is not required in an enduring framework for force acquisition. At the operational level, however, a platform that is coalition-friendly adds Credibility value. A platform that operates at extremely high levels of classification that would forbid non-US personnel using the force element, or that depends on technological enhancements that coalition partners could not support, would offer reduced value to a coalition-based coercive strategy. This will be of increasing concern in the future, as the United States is able to afford sophisticated weapons that other allied nations, though quite modern, cannot or will not.²¹

The Completed Credibility-Means Network is shown in figure 9. As before, this tree structure includes the items discussed above which represent the means by which coercion credibility is achieved. This also will be

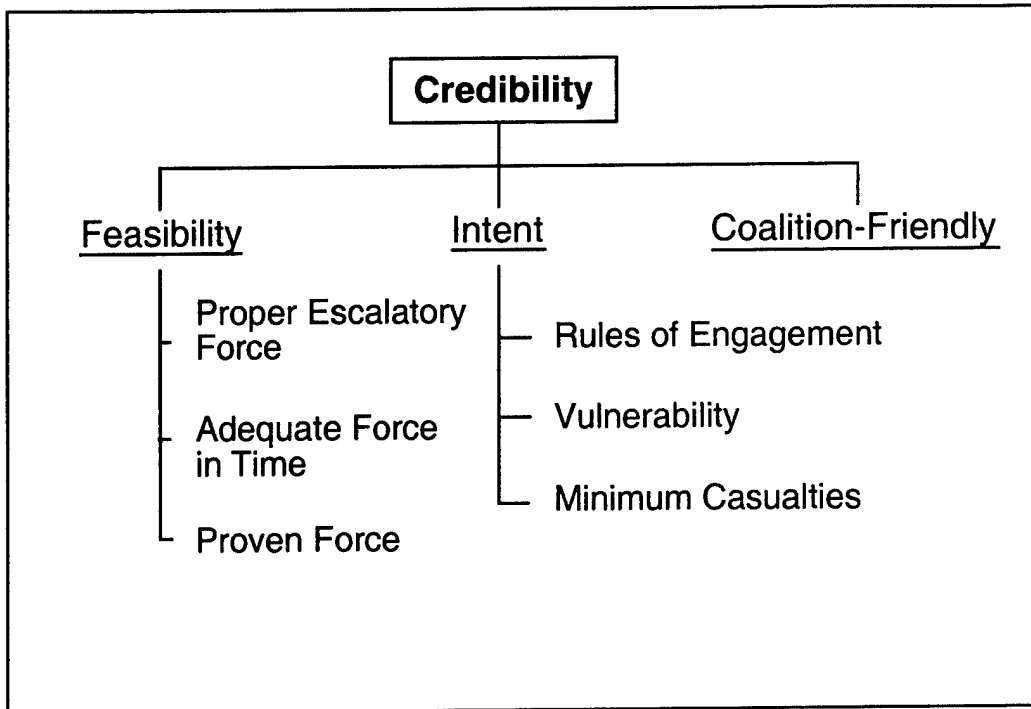

Figure 9. Completed Credibility-Means Network

used in the following chapter for a comparison of the contribution of different force elements to a coercion strategy.

Communication

Possibly the component most critical to coercion is Communication. A coercer must be able to send an ultimatum to an adversary, and it must be able to receive a response from that adversary. This is Communication. Schelling recognized the complexity of communication in conflict and described it in terms of “bargaining.”

[T]he essence of bargaining is the communication of intent, the perception of intent, the manipulation of expectations about what one will accept or refuse, the issuance of threats, offers, and assurances, the display of resolve and evidence of capabilities, the communication of constraints on what one can do, the search for compromise and jointly desirable exchanges, the creation of sanctions to enforce understandings and agreements, genuine efforts to persuade and inform, and the creation of hostility, friendliness, mutual respect, or rules of etiquette.²²

Schelling’s list of bargaining requirements and attributes is extensive, but it guides what communication can and should accomplish in a

coercive scenario. The key to effective communication from a coercer to an adversary is the ultimatum.

The classic ultimatum consists of three components: a demand made of the adversary that dictates the coercer's desired end state, a time limit for the adversary to accomplish this desired end state, and a threat of coercive action against the adversary unless and until the adversary complies with the coercer's demands.²³ In practice, the coercer's ultimatum may include all or some of these components in some measure of intended clarity. As Schelling notes, a coercer sends an ultimatum not only by word but also by deed.²⁴ The actions that a coercing force takes often speak louder, in some cases much louder, than the words it uses. The words are explicit verbal communication; the deeds are tacit communication.²⁵ This discussion focuses on the attributes of a force and a strategy that provide the means of effective communication in a coercive scenario.

Communication can be complex: the message sent by one side may not be exactly the message received by the other side. This may occur due to something as simple as a language barrier and poor translation or because of a lack of good intelligence on the context of the situation.²⁶ Adding to the complexity is the fact that warring states themselves are not unitary actors but aggregations of individual decision makers at various levels in the state structure. When a "state" ostensibly makes a decision, it is no mean feat to act upon it; word of the decision must travel through the bureaucracy to the level at which the desired action can be accomplished. For reasons ranging from bureaucratic inertia to petty office politics, sometimes the decision made is not immediately enacted. For these reasons, explicit and tacit communications can help to effectively (by working together) or ineffectively (by working in opposition) communicate decisions made from one party to the other.²⁷ The coercer needs tools that will help it send coherent communications to an adversary, both tacit and explicit, and it needs tools to help it receive communications from an adversary that may not be so clear.

We can divide the Communication component into Sending and Receiving, and we can further divide each of these into Explicit and Tacit components for clarity. The most obvious tool to explicitly send messages to an adversary is diplomacy. While traditional military tools offer little capability to directly aid diplomatic communication, they can assist with certain avenues of communication. One example is their ability to ferry diplomats to inaccessible regions for private discussions, and to do so with minimal fanfare, owing to the military's use of operational security. There are, however, more direct methods by which the military can assist in sending explicit communications. These include air-dropping leaflets explaining the nature of the conflict, the desired end-state, the rules of conduct of the conflict, and the time limits for compliance, among other things. The military can also engage in psychological operations and public affairs, such as broadcasting television and radio signals to educate

decision makers and citizens on the conflict and to condition the adversary toward acceptance of coercion.²⁸

The military has the most obvious role in sending tacit communications, notably the ability to apply force precisely. This ability is more than just dropping a precision-guided munition; it is the ability to deliver the right weapon at precisely the right point of effect at precisely the right time to enforce an ultimatum. To enhance this ability, the commander needs a protected and redundant command and control system that allows a decision maker to communicate to the force elements in minimal time.²⁹ The system allows positive control over the force so that the explicit messages are reinforced appropriately and so that the application of force is not countercommunicative. This ability should be defended from enemy attack so that it does not present a target for countercoercion. Similarly, the ability to target the adversary's command and control system will help to deny the adversary the ability to control its own forces to achieve its goals. However, a robust command and control system will allow a coercer to target the adversary's communication system judiciously, so the adversary can still respond to the coercer's ultimata.

The diplomatic corps is also largely responsible for receiving explicit communications. As well, the military can assist in this just as it can assist in sending diplomatic communications. It can also assist in receiving explicit communications by monitoring the adversary, listening in on what different elements of its leadership and force structure are saying. It can trace the line of communication from the leadership to the fielded force elements in an attempt to determine if the decision-making elements of the adversary state are explicitly communicating with its own force elements. This capability is performed by monitoring adversary communications, over both wire and broadcast, and increasingly over satellite.

A coercer also needs to monitor the adversary's actions, not just to generate targets but to receive tacit communications. Although the fog of war and bureaucratic inertia can slow the flow of information that translates a decision into action, a coercer's intelligence, surveillance, and reconnaissance (ISR) capabilities can provide an indication that the adversary is attempting to act in earnest on explicit communications. This constitutes the blurred line between explicit and tacit communications, a line that blurs both in sending and receiving. With a capability to map and monitor the adversary's command and control system, the theater commander can assess the accuracy of the adversary's explicit communications. If the tacit messages the adversary sends do not match its explicit messages, an ISR capability can help the coercer determine if the adversary is making a good faith effort to comply on the battlefield.

Figure 10 shows the Completed Communications-Means Network. This tree structure, as before, represents the means by which coercive communication is achieved. This is used in the following chapter for a comparison of the contribution of different force elements to a coercion strategy.

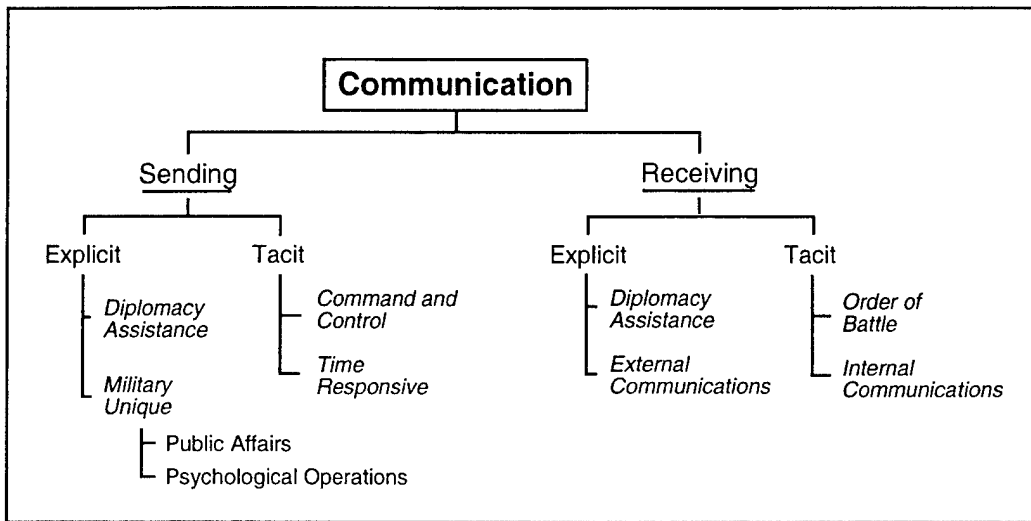

Figure 10. Completed Communications-Means Network

Summary

This chapter expanded the analysis framework to the operational level of conflict. By investigating the theory behind the three Cs of coercion, we dissected each subcomponent to determine how the platforms that execute a coercive strategy could contribute to it. The networks shown in figures 8–10 complete the hierarchy shown in figure 7. This completed framework provides a tool by which to assess the contributions of airpower platforms to a strategy of coercion. The next chapter will use this framework to discuss two specific airpower platforms and show how they can contribute to a coercive strategy.

It bears repeating that the framework developed in this study is not meant to be the final word on the enduring requirements for constituting a coercive force or a coercive strategy. It is a formal structuring of the necessary (though possibly not sufficient) elements to execute a coercion strategy. There are likely other options for structuring the essential elements of coercion, and even other elements that are not represented here, just as there are hosts of strategies for engaging in coercion. This framework, however, is unique in that it is based on rigorous academic thought, bolstered by what little real experience is available, and arranged in a fashion that offers all who would use it a justifiable basis for organizing, training, and equipping forces to prepare for executing a coercion strategy.

Undoubtedly other motivations will shape acquisition decisions. Perhaps weapon systems will be fielded and strategies developed for no other reason than the fact that they can be developed and fielded. If, however, one hopes to rationalize the acquisition and strategy-making process, this

framework can introduce a logical methodology to approach such decisions and to ensure they are made with appropriate end states in mind.

Notes

1. Forrest E. Morgan, "Compellence and the Strategic Culture of Imperial Japan" (PhD diss., University of Maryland, 1998).

2. Robert A. Pape, *Bombing to Win* (Ithaca, N.Y.: Cornell University Press, 1996), 21-32.

3. John A. Warden III, "The Enemy as a System," *Airpower Journal*, Spring 1995, 40-55.

4. Kenneth Watman et al., *U.S. Regional Deterrence Strategies* (Santa Monica, Calif.: RAND, 1995).

5. Thomas C. Schelling, *Arms and Influence* (New Haven, Conn.: Yale University Press, 1966), 3.

6. Karl P. Mueller, "Coercion and Air Power: A Primer for the Military Strategist," in *Readings Vol. IV: Strategic Airpower and National Security*, SAAS 632 (Maxwell AFB, Ala.: School of Advanced Airpower Studies Class Text, Academic Year 2000-2001), 10.

7. This ability to locate precisely targets eligible for impact may result in the selection of one mechanism of coercion over another. It is reasonable to suspect that a coercing nation can assess the sets of targets that would result in a successful strategy of punishment were they struck as required, but it may be beyond the capability of the coercing force to locate precise aim points to achieve that punishment effect. Additionally, the coercer may find no adversary targets it can attack, precluding any coercive military strategy. The ability of an adversary to deny this targeting ability is itself a form of countercoercion, which will be discussed later in considerations of defense and credibility.

8. Though traditional means of offensive attack—or impact—include bombs and other explosive and physically damaging weapons, military and other instruments of power are increasingly finding nonlethal means by which to create a tactical-level effect on an identified target. These can range from electronic warfare, which can briefly deny the adversary the ability to locate a coercer's forces by blinding its electromagnetic detection devices to computer network attack which can deny the adversary the ability to use intelligence it has gained or to give commands to lower echelon forces. For a discussion of these and other similar capabilities within the US Air Force, see Air Force Doctrine Document (AFDD) 2-5, *Information Operations*, August 1998.

9. For a discussion of the connection between the means of airpower at the tactical level and the ends at the strategic level, see Thomas P. Ehrhard, *Making the Connection: An Air Strategy Analysis Framework* (Maxwell AFB, Ala.: Air University Press, 1996), 41-48.

10. For most of its existence, the United States has been able to operate from the sanctuary of Fortress America, with little real threat to its national existence or its culture. Increasingly, there is a general threat to that former safe haven, especially in the form of weapons of mass destruction (WMD). This threat is given significant attention in the US *National Security Strategy*, where it is treated in the "Homeland Defense" section and in current debates on the national missile defense. Although the ability to defend the US homeland may provide increased capability to a coercive strategy, since it has far broader applications (and is pursued for reasons in addition to countercoercion protection), it is not considered in this framework. See *A National Security Strategy for a New Century* (Washington, D.C.: The White House, December 1999), 16-17.

11. Schelling, 36.

12. Mathematically speaking, this is the essence of the need for the defensive capability previously discussed.

13. This paradigm is taken from Watman et al., x. While the authors of that study do make extensive reference to game theory, they do not use the mathematical representation presented here.

14. For a discussion of escalation dominance, see Daniel L. Byman, Matthew C. Waxman, and Eric Larson, *Air Power as a Coercive Instrument* (Santa Monica, Calif.: RAND, 1999), 36. The authors describe it as one of their three conditions for successful coercion, in addition to "threatening to defeat an adversary's military strategy," and "magnifying third-party threats." For a discussion of the utility and the danger of thresholds, see

Schelling, 135 and 151-68. Schelling discusses conventional thresholds against the backdrop of possible nuclear warfare, where this discussion is generally limited to conventional warfare. His discussion also concedes the countercoercive mechanism of crossing a threshold the coercer cannot or will not cross. Important also is his early consideration of the threat to cities and noncombatants, and the great speed with which such "targets" can be attacked. While written in light of nuclear warfare, it applies equally to conventional warfare as described here. Probably the defining characteristic of the use of WMD as a threshold the United States seeks to avoid is their relative brutality, harming masses more quickly and more indiscriminately than conventional munitions.

15. Increasingly, airpower platforms can attack from their home bases, even home bases in the United States. Witness the B-2 strikes on Serbia launched from Whiteman AFB, Missouri, during Operation Allied Force. In such cases, there is no need to deploy; the adversary's potential targets are already within range. This attribute measures the time it takes a platform or system to be in a position to render desired effects. For such platforms that can attack from their home bases, that time is essentially zero.

16. On 30 August 1990, Saddam Hussein said, "The United States relies on the Air Force and the Air Force has never been the decisive factor in the history of wars." Dan Rather, "Excerpts from Interview with Hussein on Crisis in Gulf," *New York Times*, 31 August 1990, A-10. On the other hand, even though a force may not represent a proven force, and thus a credible force, to the adversary, it may still be quite effective in a brute force strategy. When the goal, however, is making the adversary decide to change its behavior instead of changing it for him, a force must be proven.

17. These constraints are drawn from Byman, Waxman, and Larson, 59-85. Some of the constraints not included here are considered in other sections.

18. Wayne Thompson, *To Hanoi and Back: The U.S. Air Force and North Vietnam, 1966-1973* (Washington, D.C.: Smithsonian Institution Press, 2000), xii, 35.

19. The B-2 saw extensive use in 1999's Operation Allied Force, a conflict of arguably low interest to the United States; and two dozen Tomahawk land-attack cruise missiles were targeted against sites in Sudan and Afghanistan in 1998. At \$1.3 billion, the B-2 unit cost dwarfs that of other air-breathing platforms; the Tomahawk missile costs approximately \$600,000 each, and two dozen were fired on a Sudan pharmaceutical factory alone. See *USAF Fact Sheet: B-2 Spirit*, available on-line at http://www.af.mil/news/fact-sheets/B_2_Spirit.html. Unit cost for the Tomahawk available from *The United States Navy Fact File: Tomahawk @ Cruise Missile*, on-line Internet, available from <http://www.chinfo.navy.mil/navpalib/factfile/missiles/wep-toma.html>; Jamie McIntyre, "U.S. Assessment of Thursday attacks: 'Mission accomplished,'" *CNN.com*, 21 August 1998, n.p., on-line, Internet, 14 March 2001, available from <http://www.cnn.com/US/9808/21/mission.success/index.html>.

20. Sadly, no complete, unclassified, objective review of Operation Allied Force is yet available. For a broad view of the conflict, consult William S. Cohen and Henry H. Shelton, "Joint Statement on the Kosovo After Action Review," *Defenselink News Release*, 14 October 1999, n.p., on-line, Internet, available from http://www.defenselink.mil/news/Oct1999/b10141999_bt478-99.html; John A. Tirpak, "Short's View of the Air Campaign," *Air Force Magazine*, 9 September 1999, on-line, Internet, 14 March 2001, available from <http://www.afa.org/magazine/watch/0999watch.html>; and United Kingdom's House of Commons, "Select Committee on Defence Fourteenth Report: Lessons of Kosovo," on-line, Internet, available from <http://www.parliament.the-stationery-office.co.uk/pa/cm199900/cmselect/cmdfence/347/34707.htm>.

21. For a discussion of the role of coalitions in coercion, see Byman, Waxman, and Larson, chap. 5.

22. Schelling, 136n.

23. Adapted from Alexander L. George and William E. Simons, eds., *The Limits of Coercive Diplomacy*, 2d ed. (Boulder, Colo.: Westview Press, 1994), 2.

24. Schelling, 136n.

25. This taxonomy comes from John Arquilla, *Louder than Words: Tacit Communication in International Crises* (Santa Monica, Calif.: RAND, 1993).

26. The first instance of miscommunication is intuitive. For an example of the second case, see the comment on the dialogue between US diplomatic representative April Glaspie and Iraqi president Saddam Hussein in Michael Gordon and Bernard Trainor, *The Generals'*

War: The Inside Story of the Conflict in the Gulf (Boston: Little, Brown and Co., 1995), 20-22.

27. The organizational structure of the decision-making body is critical to developing, sending, and receiving messages with another party in a conflict. For the seminal work on the implications of such considerations, see Graham T. Allison and Philip Zelikow, *Essence of Decision: Explaining the Cuban Missile Crisis*, 2d ed. (New York: Longman, 1999).

28. Missions listed in AFDD 2-5.

29. One of the standard requirements of an air campaign is the generation of an air tasking order (ATO). The Desert Storm standard ATO time cycle was 72 hours, meaning it took 72 hours from the time a target was nominated until it was attacked. While this may represent a leap in historical efficiency, it limited the commander's ability to make quick decisions and act upon them with tacit communication. For a brief discussion of the problems with the ATO cycle in Desert Storm, see Thomas A. Keaney and Eliot A. Cohen, *Gulf War Air Power Survey Summary Report* (Washington, D.C.: Department of the Air Force, 1993), 147-51.

Chapter 4

Assessing Unmanned Aerial Vehicle Contributions to a Coercion Strategy

If you had asked me about ballistic missiles in 1945 or 1946, I would have said, "Let's do it and let's do it fast," and then you would have said: "In what particular way will you apply this in a possible war," and I would have told you, "I don't know, but once we make it we will find some use."

—Dr. Edward Teller
Testimony before the US Senate
25 November 1957

The character of military forces is partly determined by geography, partly by the way technology unfolds over time, partly by conscious choices in the design and deployment of military force.

—Thomas C. Schelling
Arms and Influence

There is an allure to technology, demonstrated by Dr. Edward Teller's words, that beckons us to build new equipment, especially equipment for military purposes. In this technological age, advantage accrues to the one who can first employ the better tools of warfare. As the costs and the risks of technology rise, we must be prudent in the technologies we choose to pursue and the reasons we choose to pursue them. The Soviets, for example, pursued more and better weapons to their financial and political oblivion. Hitler sat atop a gold mine of technological talent and labor in his country during World War II, but without a clear and articulated strategy for the employment of such technological capability, that gold mine could not win Germany's war. These and other examples offer lessons to us, though they may seem to apply only loosely. Schelling states that the "conscious choices" we make shape the character of military forces. One hopes we have learned enough to make these choices prudently. The framework this study presents is designed to help us do just that.

In this time of relative peace, the United States looks to undertake measured improvements in force structure, and to do so as economically as possible. Along these lines, the DOD has invested significant sums to develop unmanned aerial vehicles (UAV).¹ More recently, the Air Force has begun investigating the development of unmanned combat air vehicles (UCAV). A UAV, for the purposes of this discussion, is a reusable air-breathing vehicle that flies without a human physically aboard the aircraft. It can fly a set course (in which case it might also be called a drone), it can be guided by directions from off board the aircraft (in which case it

might also be called a remotely piloted vehicle [RPV]), or it can be guided by either means at various times during flight. Modern UAVs and UCAVs fall into the last category. A UCAV differs from a UAV in its combat mission, although it is largely a semantic and political difference. While a UAV typically performs a reconnaissance or surveillance mission, a UCAV delivers weapons against enemy targets. A UCAV differs from a guided munition in that it returns from its mission for reuse; a guided munition does not.

The Global Hawk high-altitude endurance unmanned aerial vehicle (HAE UAV) program and the unmanned combat aerial vehicle advanced technology demonstration (UCAV ATD) program are two current developmental unmanned aircraft programs. These two programs provide an opportunity to study how the United States develops the latest generation of technology, striving to apply it to its combat needs in a peacetime environment. By examining the contributions of each of these developmental aircraft with the analytical framework developed thus far, we can demonstrate how each of these vehicles contribute to a coercive strategy while simultaneously demonstrating the efficacy of the framework. Before looking at the programs individually, we begin with a brief historical discussion on UAVs and UCAVs.

Background

Pentagon planners discussed the use of drones as platforms for intelligence gathering as early as 1959, with the express notion of preventing political fallout should an adversary shoot down a manned reconnaissance platform and capture American aviators. The Ryan Aeronautical Company (later Teledyne Ryan) had developed the Firebee drone some years earlier as a target for missile and gunnery crews in surface-to-air and air-to-air engagements. Although Ryan realized the Firebee could be modified for reconnaissance as early as 1955, the Defense Department saw no need for such a device until the Soviets began deploying hundreds of SA-2 (then V-75) systems throughout the Warsaw Pact area in 1958.² Many within the Defense Department sought a counterresponse to this technology, seeing the political danger should one of the US surveillance aircraft be shot down.³ The Soviet shootdown of Francis Gary Powers's U-2 reconnaissance plane on 1 May 1960 confirmed this fear. The first useful satellite reconnaissance images of the earth were still some months away at the time, so a reconnaissance UAV provided an obvious way to prevent a repeat political fiasco. The Air Force contracted with Ryan to develop a reconnaissance RPV from the Firebee drone under the code name Red Wagon. This program, regrettably, was cancelled later that same year (considered "a waste of time"), much to the chagrin of political leaders later during the 1962 Cuban missile crisis. That situation saw yet another U-2 shot down, this time killing the pilot, as it was collecting data to confirm details of Soviet nuclear missiles deployed to Cuba.⁴ This act reignited the development of the Ryan system, just in time for Vietnam.

Modern reconnaissance UAVs became possible with the maturation of photographic reconnaissance capability and drone technology plus a perceived need for the contributions such a vehicle could provide. While it was technologically possible to produce a reconnaissance UAV well before Ryan did so, there was no mission that required it. Not until surface-to-air missiles (SAM) downed U-2s and aircrews (and the likelihood of it happening again soared in the face of the Vietnam conflict) did DOD decision makers realize the UAV's worth. During this time frame, Dr. Harold Brown, director of Defense Research and Engineering (and later secretary of the Air Force and secretary of Defense) wrote a paper documenting the useful characteristics of UAVs in a reconnaissance and surveillance role. In it, he noted that a UAV would minimize the political risk of conducting reconnaissance by removing possible enemy prisoners, such as Powers, from the vehicle; it would reduce the technical complexity and the size of a reconnaissance vehicle because it would not have to support a man; and it could be made less detectable, and thus more survivable, because of its smaller size. Furthermore, there was little value added by having a man aboard this type of aircraft because engineers could program the sensors to record automatically. Finally, a man in the aircraft effectively limited the utility of the aircraft sensors in risky situations: with no human to put in danger, a UAV could continue to assess improvements in the enemy's defenses until it was eventually lost. These were precisely the contributions of the belated UAV program that proved so successful during the Vietnam conflict.⁵

The Ryan Firebee (see fig. 11) and other reconnaissance UAVs saw significant duty in Vietnam, flying nearly 3,500 missions over China, North Vietnam, and other areas of the Far East between 1964 and 1973 with—by some reports—only 4 percent losses.⁶ When they flew, although obviously of US design, they were frequently stripped of their US insignia, thus mitigating the political impact should one be shot down. On these missions, UAVs collected photographic and electronic emissions intelligence on enemy forces, helping to build a picture of the ground order of battle and the air defense system. These vehicles were especially useful in helping the US aviation forces combat the North Vietnamese surface-to-air threat by identifying missile radar and guidance operating frequencies so that electronic countermeasures could be designed without risking aircrew lives.⁷

Vietnam also saw the emergence of the first modernUCAV. In addition to their reconnaissance and surveillance missions, drones in Vietnam also dropped "propaganda leaflets intended to demoralize North Vietnamese citizenry."⁸ AUCAV is conceptually different from a UAV in that its mission is to deliver munitions to a target, whereas the UAV mission is to collect information on a target and deliver it to friendly forces. Clearly, the two vehicles share many technological attributes, but politically (and perhaps morally), there is a basic difference in the use of the two. It is easier to justify using a robot to take a picture of the adversary: no lives are directly threatened on either side. It is somewhat more difficult to justify

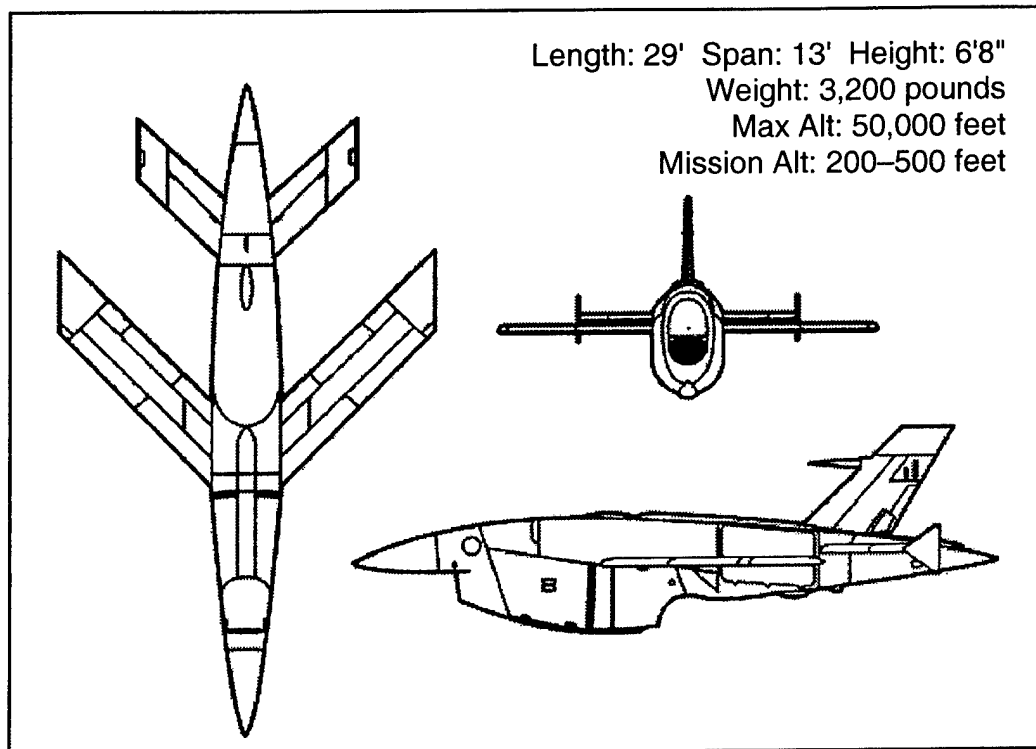

Source: "Firebee" ("Teledyne Ryan AQM-34L 'Firebee,'" US Air Force Museum Modern Flight Hangar, Wright-Patterson AFB, Ohio); "BQM-34 Firebee II (Teledyne Ryan)"; Field Manual (FM) 44-80, *Visual Aircraft Recognition*, Army Air Defense Artillery School, 1996; and "Chapter 12: Unmanned Aerial Vehicles and Cruise Missiles" (Fort Bliss, Tex.: US Army Air Defense Artillery School, 1996).

Figure 11. Teledyne Ryan AQM-34L

using a robot to drop a bomb on the adversary; the enemy is threatened without a proportionate threat to the antagonist.⁹ Perhaps this difference between the two systems helps explain the very limited development UCAVs have seen until recently. Toward the end of the Vietnam War, spurred by losses to SAMs, Ryan began modifying its family of drones to carry munitions, especially those suited for enemy air defense suppression. These UCAVs first dropped chaff corridors to shield incoming bombers; later SAMs were mounted on test vehicles. By 1978 (sadly for Ryan and the United States, well after such vehicles were needed), Ryan had successfully tested a multimission-capable UCAV and had even flown two in formation. As it turned out, there was neither an exigent need for the vehicle in the United States nor funds for further development, and the program died shortly thereafter.

After the Vietnam experience, US interest in UAVs waned as well, without the motivation of a current conflict to spur continued development. Israel, however, picked up the torch of UAV development and made significant strides in incorporating them into its force structure and battle plans. In October 1973, during the Yom Kippur War (although information

is sketchy) it appears a Ryan Firebee UAV was used on both the Egyptian and Syrian fronts to gather intelligence and to stimulate enemy SAM activity, causing the enemy to fire missiles uselessly prior to Israeli pilots arriving overhead. In operations over the Bekáa Valley in 1982, the Israelis flew several of their own low-cost mini-UAV designs to collect photographic and electronic intelligence, in some cases returning real-time imagery from over Syrian airfields. Though not the single cause of the Israeli's dominant victory in this battle, UAVs certainly made a major contribution.¹⁰

Perhaps spurred by Israeli success, the United States pursued several UAV designs of its own during the 1980s. Two were the battlefield intelligence-collecting Aquila and the classified endurance UAV Amber, both of which were cancelled by 1990. Probably the most successful UAV program thus far, also begun during the 1980s, was the Pioneer UAV program. This Israeli-designed platform saw duty in Desert Storm and Bosnia and is still in service with Navy and Marine Corps units, although it appears to be near the end of its useful life. The General Atomics Gnat-750, also begun in the late 1980s, is still providing useful reconnaissance information for the Central Intelligence Agency, the Department of Energy, and several foreign countries. Currently the USAF has enjoyed great success with the Predator UAV, a follow-on vehicle to the Gnat-750. This was the first of what the Air Force hopes will be a string of productive endeavors resulting from a new concept in UAV design and acquisition.¹¹

In 1987, driven by a perception that there were multiple misguided and duplicative UAV efforts within the DOD, Congress mandated that DOD consolidate its nonlethal UAV design efforts. This led to the creation of the UAV joint program office (JPO) in the spring of 1988 to answer this critique. The UAV master plan published in 1988 and modified several times over the following years set out a course for UAV development that generally included three categories: tactical, medium-altitude endurance, and high-altitude endurance UAVs.¹² This guidance alone, however, was not enough to overcome all the difficulties that UAV development within the United States has faced.

Traditionally, UAV development has suffered from three problems. First, UAVs use technologies that are not simple to develop. Not only does the concept of flying an aircraft without the pilot on board involve challenges of creating control mechanisms and communications protocols, but also simply plugging that vehicle and its products into the war-fighting mechanism is difficult without the traditional operator interface. Second, with limited funds for UAV development (with relatively lower cost UAV programs walking in the shadow of very much larger DOD acquisition programs), there are many demands for what the lower-cost UAVs seem able to deliver. This typically results in what is commonly called "requirements creep," or the tendency of DOD to add requirements to the design while it is in development. This tends either to delay final production or to result in compromises in the final design that satisfy no one. Compounding this is the

fact that the reconnaissance needs for each service are decidedly different; and currently there are only three development programs, mentioned above, to satisfy all needs. Third, since UAVs attempt to satisfy many users simultaneously, there has rarely been a single strong proponent of the technology, thus turning them into technological orphans. The UAV JPO is an attempt to correct that problem; but since it is a single office attempting to fill the needs of many users simultaneously, it is struggling to do so.¹³

The advanced concept technology demonstration (ACTD) program offers a way to help the UAV development process. This program began in 1994 on the recommendation of the 1986 Packard Commission, which suggested that there must be better ways to streamline the acquisition process and reduce costs. ACTDs apply mature technologies directly to war fighter-identified problems in relatively low-cost programs that demonstrate to the war fighter the effectiveness of those technologies quickly (in two to four years, versus the decade[s]-long traditional acquisition programs). The war fighter is integrally involved in the ACTD and essentially has the final say regarding its value. Given a relatively small development budget and the motivation of satisfying a war fighter's demands, ACTDs apply mature technologies to accomplish this task in innovative ways. What makes the ACTD program useful for UAV development is the fact that many of the technologies involved in reconnaissance UAVs are mature. Reconnaissance itself was one of the earliest missions of aerial vehicles. The remote and computer control mechanisms are now reasonably well understood, especially following Israel's experience. Advances in solid-state electronics make it even more feasible to put instruments capable of detecting valuable enemy information onto a small airborne platform.¹⁴ Although ACTDs may not overcome the problem of ownership identified above, they have the potential to help overcome the technological speed bump by relying on mature technologies; and they can mitigate requirements creep by focusing on specific concerns of the war fighter.

The UAV ACTD effort, in association with the Defense Advanced Research Programs Agency (DARPA), has met with some success. The predator, designed to fill the medium-altitude endurance role, has been the star pupil of the class thus far, entering low-rate production and providing useful intelligence in two operations over the Balkans. Global Hawk, the HAE reconnaissance UAV, appears to be the next success story as it continues testing and enters production. Two other ACTDs have been less successful. DOD cancelled Dark Star, the stealthy version of Global Hawk, after integration problems, early crashes, and cost overruns. Involving "maturing" technologies, Dark Star proved too expensive for the capabilities it provided, although it did fly successfully before cancellation. Outrider, the tactical UAV program, has met with integration problems and requirements changes. The only tactical UAV in development in the master plan, the outrider is attempting to satisfy several different users, but that is becoming harder as demands change. It has run into significant

technological and financial difficulties during development, but it still survives. Overall, however, the ACTD program appears to have helped the development of UAVs in comparison to previous efforts.¹⁵

The X-45 UCAV is being developed under a similar concept with DARPA—the advanced technology demonstration (ATD) program. An ATD differs from an ACTD in several important ways. The ATD deals with cutting edge technologies; the ACTD deals with mature or maturing technologies. An ATD responds to a performance requirement; an ACTD responds to a particular war fighter need, although both involve significant war-fighter participation. A single military service typically drives an ATD; an ACTD is typically a joint program, with lead service direction occurring later in the program. The ATD applies when the program is attempting to demonstrate unproven capabilities and newer technologies, with an eye to fielding technologies or systems in several years. The ACTD generates a relatively quick response specifically to fill a war-fighter requirement for a weapon system, and it uses mature technologies to do it.

The Global Hawk and UCAV programs, products of the latest efforts at incorporating technological improvements into military weapon systems, provide two sample weapon systems that will allow us to test the framework developed in previous chapters. They are both immature programs, with significant funding and development decisions yet unmade. Both offer new and potentially revolutionary capabilities to the theater commander, and they appear to offer great promise across the spectrum of conflict. But how might they fit into a strategy of coercion? By looking at the qualities, capabilities, and characteristics of each weapon system, we can assess how they fit into such a strategy. More importantly, we can also assess the contributions of the framework to an analysis of force structure and acquisition decisions. We will begin with the better developed program.

Global Hawk

The Global Hawk HAE UAV program began as an ACTD in 1995, designed to fill war-fighters' requirements for "near real-time reconnaissance capability against high-value, well-defended targets."¹⁶ The overriding objective of the HAE UAV ACTD program was to produce a vehicle that could satisfy as many of the war-fighter demands as possible while meeting a fixed-unit flyaway price of \$10M per vehicle. The Global Hawk was one-half of the HAE UAV program; Dark Star, its stealthy cousin, was the other half. While both were completely new vehicles, Dark Star differed from Global Hawk with its stealthy exterior, its smaller sensor suite, and a capability designed to penetrate enemy defenses unseen. Dark Star, however, was cancelled in 1999. They were grouped together in the design process in the hopes that both could use a common ground segment—discussed later. Both vehicles pushed the edge of the ACTD concept, relying on "maturing" instead of "mature" technologies per the original wording of

the ACTD charter. While both programs filled different niches, both responded to the same general war-fighter needs. Although the Dark Star ACTD ended without it entering into production, many of the technological concepts demonstrated during its lifetime will be useful to other programs. In the pure sense of the ACTD process, Dark Star was certainly not a failure. Global Hawk, on the other hand, was able to fulfill the HAE UAV requirements for less in developmental costs. For this reason, DOD selected Global Hawk to transition to production following the end of the ACTD program in 1999.¹⁷

In addition to the basic requirement mentioned above, Global Hawk employed a suite of sensors and communications capabilities to provide broad information, surveillance, and reconnaissance coverage of the entire battlefield for both commanders and tactical units on and near the battlefield. It will do this by flying sorties at high altitudes for extended periods of time, imaging the battlefield with electro-optical (EO), infrared (IR), and synthetic aperture radar (SAR) sensors (see fig. 12). The UAV will pass that imagery to a ground station for processing and transmission to user sites or retain it until it can pass it later. Flight at higher altitudes increases survivability, and the vehicle has provisions for onboard threat assessment and electronic countermeasures for additional survivability. Critical to the vehicle's utility is its ability to transfer the imagery via line-of-sight (LOS) communications links or via satellite, making the imagery available to a host of theater users simultaneously.

System Description

The Global Hawk system consists of three elements: an air vehicle segment, a ground segment, and a support segment.¹⁸ The air vehicle segment includes the Global Hawk HAV, complete with avionics, communications equipment, and the sensor suite, with both a SAR for radar imagery and a combination EO/IR sensor for visual and infrared imagery (see fig. 13). The sensor suite includes a ground moving target indicator (GMTI) and the ability to process data and transmit that data in uncompressed or compressed formats. The EO/IR sensors can operate in a wide area search, spot collection, point target (continuous stare), and stereo modes. The vehicle, about the size of the U-2, can fly for extended periods of time and across long ranges without human interaction, allowing it to self-deploy and conduct reconnaissance from extended ranges. Course and mission changes can be passed to it in flight via LOS or satellite communications links. The vehicle also carries a threat warning receiver and a threat deception system, including electronic jammers, expendable decoys, and a towed decoy system, all of which are capable of manual or automated operation. Appendix A lists complete performance parameters for Global Hawk.

The ground segment includes a mission control element (MCE) and a launch and recovery element (LRE). Five persons at individual workstations typically man the MCE: a mission planner, a command and control operator,

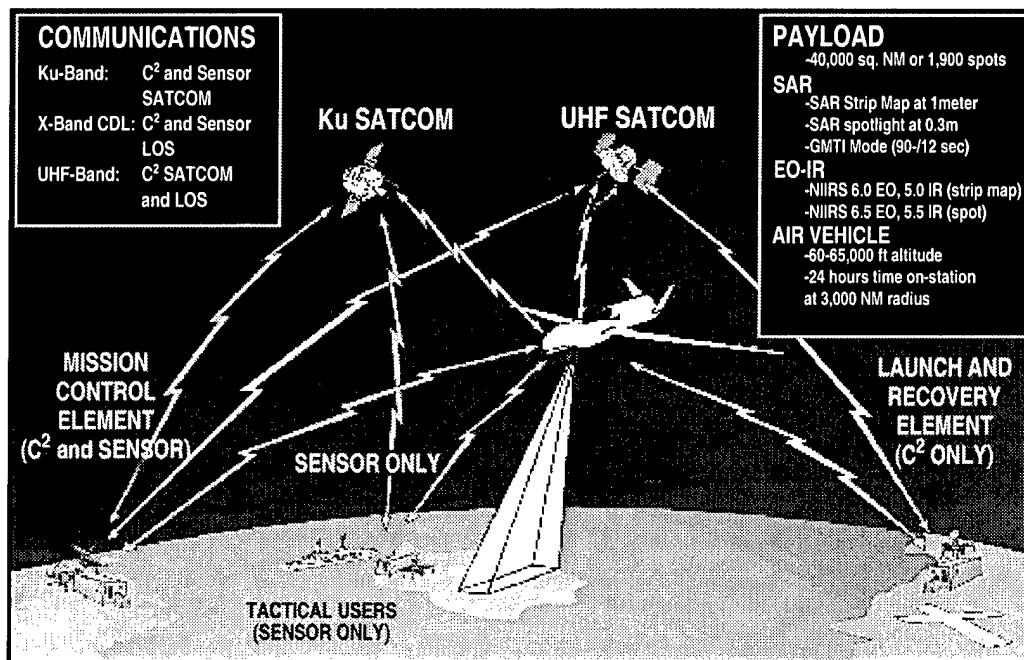

- Legend:
- CDL—common data link
 - C²—command and control
 - EO-IR—electro-optical infrared
 - GMTI—ground moving target indicator
 - LOS—line of sight
 - NIIRS—National Imagery Interpretability Rating Scale
 - NM—nautical mile
 - SAR—synthetic aperture radar
 - SATCOM—satellite communications
 - UHF—ultrahigh frequency

Source: "RQ-4A Global Hawk Command, Control, Communications, Computers and Intelligence Support Plan," draft (Wright-Patterson AFB, Ohio: Aeronautical Systems Center Global Hawk Program Office, 24 March 2000).

Figure 12. Global Hawk System Concept Overview

an image quality control specialist, a communications manager, and the mission commander. From the MCE, controllers can plan the mission, re-task the UAV inflight, monitor the mission progress, activate sensors, and respond to air traffic control direction as if an operator were aboard the vehicle. The MCE can monitor up to three UAVs simultaneously. The MCE's data processing positions allow it to process imagery and disseminate it in less than 30 seconds. It can also provide unprocessed imagery directly to selected users. The LRE, as the name implies, is responsible for physically and electronically launching and recovering the UAV. The principle difference between the LRE and the MCE is that the former lacks the image processing capability and the wideband data transmission links (to users) while the latter lacks the precision navigation equipment for ground operations, takeoff, and landing. The LRE and MCE do not need to be collocated. When they are collocated, they can communicate via

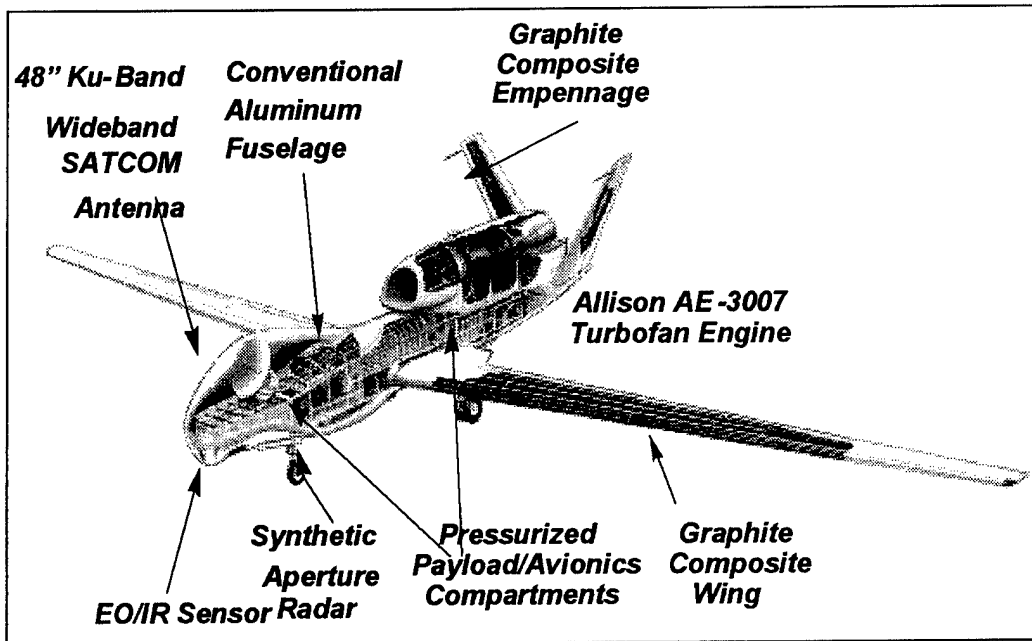

Source: Air Combat Command Concept of Operations for the Global Hawk Unmanned Aerial Vehicle (Langley AFB, Va.: Headquarters AC2ISRC/C2U, August 2000), 2-6.

Figure 13. Global Hawk Vehicle

landline links; otherwise, they can communicate via LOS or satellite link, thereby providing additional deployment flexibility.

The support segment contains all the equipment, spare parts, repair tools, and trained personnel to maintain the vehicles and support equipment (including LRE and MCE). This includes power generation equipment, testing equipment, and adapters and interface gear to allow operation at relatively bare bases. Mission spares kits (MSK) for deployed operations will typically provide sufficient provisions for 30 days of operations at a deployed location. While the support segment supports vehicles, LRE, and MCE at a single deployed location, when the two elements of the ground segment are not collocated, a larger support segment is required.

With Global Hawk vehicle self-deployment, the entire system fits within three C-141s. Design goals for transportability include pack-up and set-up times of 24 hours for each, but initial analysis shows actual times on the order of 12 hours each. The Global Hawk system will require considerable host-base support, including vehicles, security, theater logistics, and administrative support. While much of the intelligence product can be delivered and disseminated via satellite link, ground-line hookup—if provided within the theater—can also accommodate ground networked users.

Contributions to a Strategy of Coercion

The Global Hawk focus on filling valid war-fighter mission needs is useful to avoid the exuberant pursuit of technology without military justification. These needs, however, are relatively broad. How precisely does a capability to provide "near real-time reconnaissance capability against high-value, well-defended targets" contribute to a war fighter's strategy? Connecting the science of technology to the art of strategy can prove difficult. The framework presented in this study provides just such a tool. By considering the specific capabilities and qualities required of military hardware to effect a strategy of coercion, we can connect the promise of technology with the reality of strategy. Figure 14 shows the means networks for each of the three Cs.

Beginning with Capability, we can work through Global Hawk's attributes. Its major offensive contribution is a capability to find targets. With EO, IR, and SAR imagery and its GMTI capability, the Global Hawk can help assess an adversary's intentions by noting troop movements and force buildups. It can provide near-real-time imagery that defines targets and locates fleeting impact points, thus opening up a wider range of target opportunities for the theater commander. With its extensive ability to communicate images and information throughout the theater, Global Hawk increases the ability of other weapon systems to attack these fleeting targets, even though it cannot attack those targets directly. Following an attack, Global Hawk can survey the target area to assess the attack and determine the tactical effect achieved. Without an ability to monitor other communications, however, it cannot assess operation and higher effects.

Defensively, Global Hawk flies at high altitude with extensive self protection measures. With onboard logic for employing these systems, coupled with operator intervention as required, the UAV will be very survivable. While it is designed with standoff reconnaissance in mind, Global Hawk's survivability features allow it to penetrate low- to medium-threat airspace for limited periods of time with lower risk than traditional aircraft like the U-2, which is not designed to penetrate current adversary airspace. Global Hawk is designed to protect the system by putting only essential elements at risk: the ground segment can be split, and the vehicle itself can fly intercontinental distances autonomously and still remain on station long enough to provide useful reconnaissance and surveillance information. Because it has on board threat monitoring equipment and can transmit that information in near real time to the MCE and other users in the theater, Global Hawk can help build a threat order of battle that can help to protect the rest of the force (total force protection).

It is too early in the program to assess how many Global Hawk vehicles and supporting systems will be required to execute a coercive strategy. Should they prove as useful as they appear to be, they will likely suffer

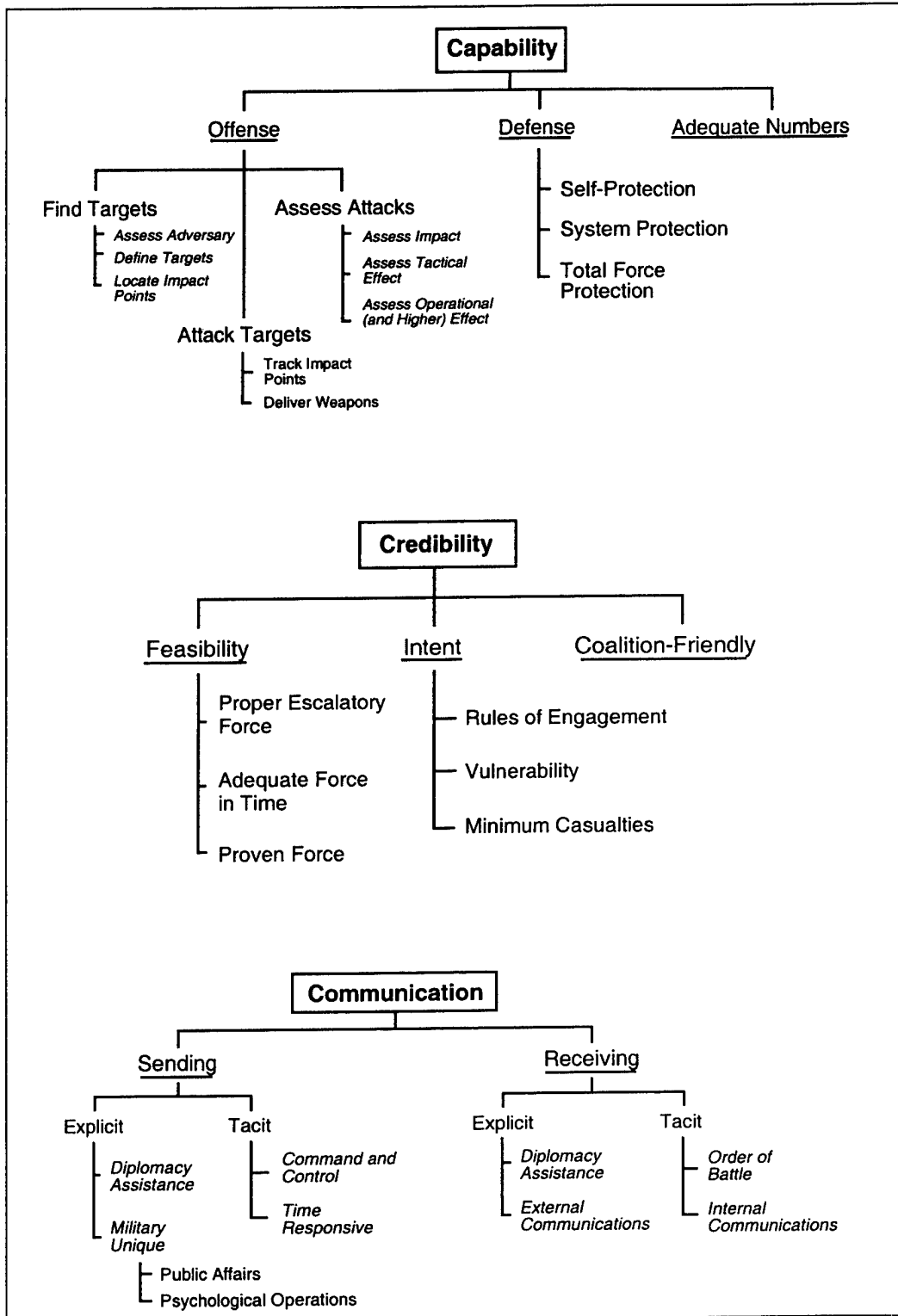

Figure 14. Means-Ends Networks for the Components of Coercion

the curse of airpower: too many needs for too few vehicles, no matter how many there are. However, as a minimum, the Global Hawk either by itself or in coordination with other reconnaissance and surveillance vehicles must provide continuous coverage of the entire battle area.

Moving to Credibility, the use of Global Hawk appears to add much to the proper escalatory force: its presence is an escalation and it can serve as part of either a punishment or denial strategy by providing target imagery for both types of target sets. If the system is as useful as it is designed to be, it will likely be part of an adequate force; and its ability to rapidly deploy to the theater, especially the ability of the vehicles themselves to self-deploy, makes for a timely response. As with most new technologies, however, until it has proven its utility in conflict, an adversary may not accept it as a coercive weapon system.

The use of Global Hawk in a coercive strategy appears to meet the requirements for political intent. Assuming the system can work with other aircraft, it should conform to rules of engagement (ROE). With its survivable design, it should meet criteria for minimized vulnerability, even with a very limited national interest at stake. Clearly the lack of aircrew onboard minimizes the threat of casualties; but more than that, the design of the system that minimizes the risk to support personnel adds much to the will to use Global Hawk in this scenario. Additionally, the multiple sensors and wideband communications capability allow Global Hawk to provide near-real-time target updates that can help minimize adversary civilian casualties.

UAVs in general appear to be coalition-friendly, assuming they can demonstrate an ability to work well alongside manned aircraft. In addition to the US UAV systems flown in support of the air war over Serbia, France, Germany, and the United Kingdom flew their own UAVs. They suffered losses to their UAVs as well, so they are familiar with the risks.¹⁹ Western allies also appear to be particularly enamored of US efforts to harness technology in support of coalition war fighting, especially if that technology is available to the entire coalition. With low unit costs (and much of the development already borne by the United States), the Global Hawk system would appear to be very coalition-friendly.²⁰

Global Hawk also has a role in sending tacit communications. The redundant command and control system connected to the ground segment, using both LOS and satellite communications, and an ability to communicate with nearly all existing intelligence systems provides the theater commander precise control over his imagery capability. This control can help direct force employment exactly where it is required with minimal delay between target detection and target attack. Global Hawk can assist with receiving tacit communications as well—providing EO and IR receipt of tacit signals from the battlefield, confirmation of adversary force movement away from the battlefield and a less threatening order of battle.

The unique capabilities and qualities of the Global Hawk system make it an easy weapon system to fit into a coercive strategy. Table 1 graphically

Table 1

Contributions of Global Hawk and UCAV to a Coercion Strategy

Qualities, Capabilities, and Characteristics that Contribute to Coercion	Global Hawk	UCAV
Capability		
Offense		
Find Targets		
Assess Adversary	G	R
Define Targets	G	R
Locate Impact Points	G	G
Attack Targets		
Track Impact Points	Y	G
Deliver Weapons	R	G
Assess Attacks		
Assess Impact	G	G
Assess Tactical Effect	G	Y
Assess Operational Effect	R	R
Defense		
Self-Protection	G	Y
System Protection	G	Y
Total Force Protection	Y	Y
Adequate Numbers	?	?
Credibility		
Feasibility		
Proper Escalatory Force	Y	G
Adequate Force in time	Y	G
Proven Force	R	R
Intent		
Within Rules of Engagement	G	G
Vulnerability	G	G
Minimal Casualties	G	G
Coalition Friendly	G	G
Communications		
Sending		
Explicit		
Diplomacy Assistance	R	R
Uniquely Military		
Public Affairs/Propaganda	R	R
Psychological Operations	R	R
Tacit (Force Employment)		
Agile Command and Control	G	G
Responsive to Commander's Needs	G	G
Receiving		
Explicit		
Diplomacy Assistance	R	R
External Communications	Y	R
Tacit (Adversary Force Assessment)		
Order of Battle	Y	R
Internal Communications	R	R

Legend: G (Green) = Platform provides this capability; Y (Yellow) = Platform provides part of this capability; R (Red) = Platform provides none of this capability; ? = Platform's contribution unknown.

shows its contributions. It is clear how it can add to that strategy and how it can strengthen the capabilities of traditional air vehicles. The framework provides an easy tool to assess exactly where Global Hawk fits into this strategy without requiring extended quantitative analysis. While it is not intended to substitute for modeling and simulation, it provides a qualitative force assessment and allows for easy communication between the strategist and the technologist.

As stated in chapter 2, a decision analysis framework not only guides decision makers when there is an obvious decision to make but it also shows where new decision opportunities can arise. Although the utility of Global Hawk as described in the literature is clear, the framework shows how developers can further increase that utility in a coercion strategy. Consider the following examples. The Global Hawk's onboard imagery and communications systems allow it theoretically to pass target information (impact points) directly to an attacking aircraft. By allowing Global Hawk to transmit directly to a weapon (dropped by another aircraft) via data link, the MCE operator could guide the bomb directly to impact through Global Hawk, in effect giving the UAV system an ability to track impact points and to guide precision weapons. Additionally, adding a laser designator to Global Hawk—as was done with the Predator UAV after Bosnia—may give it another capability to track impact points and assist in weapon delivery. Finally, different sensors on board Global Hawk could give it an ability to monitor electronic signals and internal communications that could enhance a capability to receive explicit and implicit adversary communication. Without conducting operational tests or using the platform in actual combat, the framework clearly shows obvious avenues for improvement.

As an aside, it is interesting to compare the contributions of the cancelled Dark Star UAV program and the more successful Global Hawk using this framework. Both UAVs were designed to fill the HAE UAV role for the military; but in early 1999 DOD realized that the Global Hawk program was sufficient, especially in light of funding overruns, to fill the war-fighter's needs. Can the framework provide any insight into where Dark Star fell short while Global Hawk did not?

While Global Hawk's sensor suite allows simultaneous use of the EO/IR sensor and the SAR, Dark Star did not. Furthermore, Dark Star's sensors had much more limited range and they did not have GMTI capability, further limiting the reconnaissance value. Dark Star had the ability to penetrate adversary threats where Global Hawk does not, which gives it the ability for higher-resolution imagery and possibly obviating the need for longer-range sensors. Unfortunately, it did not have the ability to stay there long: it had only a third of the loiter time of Global Hawk and a sixth of the operating radius. Dark Star did not have as extensive a communications payload as Global Hawk. It had no Ku-band satellite uplink capability, making near-real-time mission changes from long range infeasible. It operated with the same ground segment Global Hawk used, however, making its

product available to nearly all theater users. Surprisingly, it was not equipped with an onboard threat warning receiver or electronic counter-measures. Presumably, its stealth qualities removed the need for this.²¹

Dark Star had clear advantages over Global Hawk in its ability to penetrate threat areas, but those advantages appear to have come at a cost. Dark Star had a much less capable sensor suite and noticeably reduced range and on-station time. With that reduced range, deployment time was longer (since it could not self-deploy as Global Hawk can), thus providing a much less responsive capability, especially early in a conflict when stealth is so highly valued. Because of limitations in Dark Star's contributions to capability and credibility, it is not surprising DOD cancelled the program in favor of Global Hawk.

Although stealth technology was one big difference between the two HAE UAV programs, stealth technology certainly does not preclude a vehicle from contributing to a coercive air strategy. The UCAV program demonstrates that a stealthy platform can indeed offer capabilities and qualities that make it very well suited to such a strategy.

UCAV

Based on recommendations in the Air Force *New World Vistas* report in 1995 and on a subsequent Air Force Scientific Advisory Board study the next year, the Air Force and DARPA entered into an agreement in October 1997 to conduct the UCAV ATD program.²² The goal of this program is to develop an affordable weapon system that can employ lethal airpower against an adversary with minimal risk to friendly lives and equipment. The specific focus for the UCAV program is on suppression of enemy air defenses (SEAD) and strike missions. UCAVs are envisioned to operate early in a conflict, performing the high-risk missions against heavily defended targets that traditionally incur the greatest losses in an air war. They also are expected to be a critical part of the order of battle throughout a conflict, meaning UCAVs must be able to operate with other UCAVs, UAVs, and manned aircraft. Like the Global Hawk design, a central station will control the UCAV, although many of its functions will be highly automated (fig. 15). While no cost goal is defined, as it was in the Global Hawk program, the government believes that the unit cost of the UCAV could be as low as one-third that of the Joint Strike Fighter.²³

Since the program is an ATD and the technologies are much less mature than those found in the Global Hawk program, designers hope to demonstrate the utility of the UCAV concept so that a follow-on acquisition program could build an initial operational capability sometime after 2010.²⁴ Correspondingly, at this point the UCAV system is more broadly defined than the Global Hawk system. Boeing is designing the current UCAV ATD system.

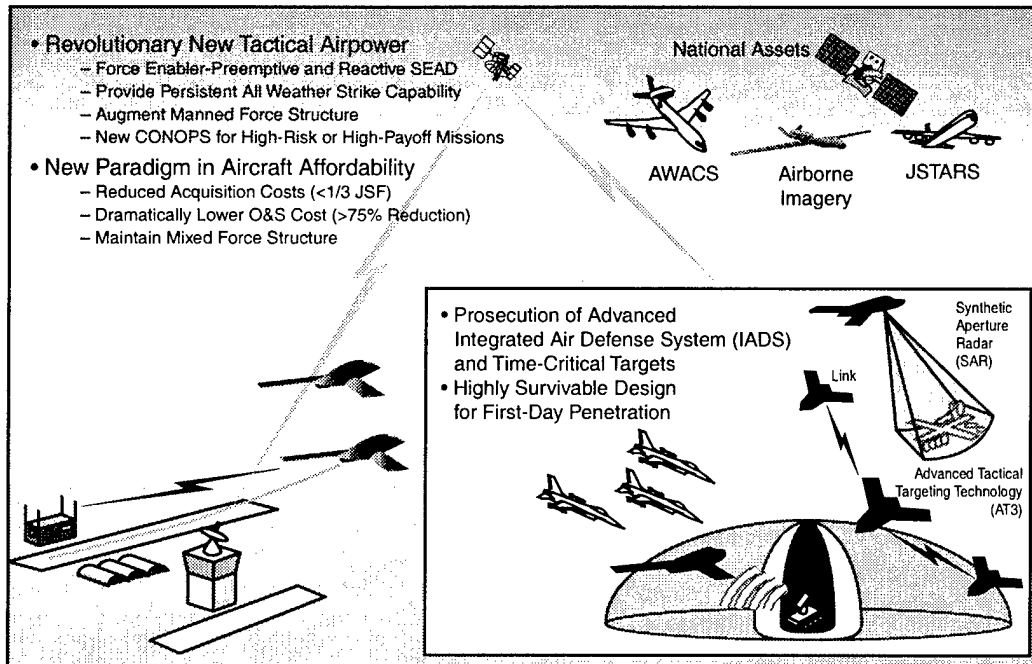

Source: Michael Leahy, DARPA/USAF Unmanned Combat Air Vehicle Advanced Technology Demonstration: Promise and Progress (PowerPoint presentation, April 2001, slide 2).

Figure 15. UCAV System Concept

System Description

Much like the Global Hawk system, the UCAV system includes three segments: the air vehicle segment, the mission control segment (MCS), and the supportability segment.²⁵ The UCAV air vehicle segment is about two-thirds the size of an F-16 and uses stealth technology to reduce detection by enemy radar. It is being designed to carry a range of munitions, but the weapons bay is limited by size (fig. 16). At present, it will carry as few as two 1,000-pound bombs or as many as 12 small smart bombs. The UCAV's utility will increase dramatically as DOD develops and fields more small precision munitions, allowing it to strike many targets per mission. Designed for the strike role, it does not have an extended loiter time capability as does the Global Hawk, but it does allow for typical fighter ranges.

The MCS provides the command and control facilities for the UCAV. Much like the Global Hawk system, it includes friendly air operations (FAO) and the area of responsibility (AOR). The FAO section controls the base operations and transit to and from the target area. The AOR section controls the vehicle through its ingress and egress routes and its operations in the target area. Importantly, the AOR section will provide near-real-time weapons release authorization. While the UCAV will have considerable

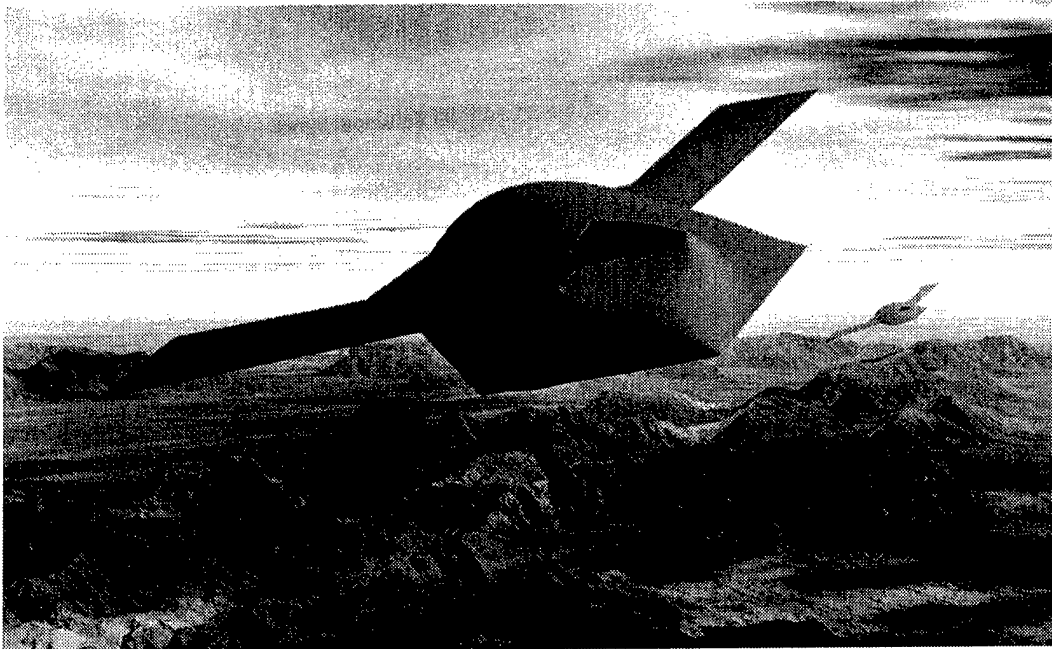

Source: Michael Leahy, DARPA/USAF Unmanned Combat Air Vehicle Advanced Technology Demonstration: Promise and Progress (PowerPoint presentation, April 2001, slide 1).

Figure 16. UCAV Air Vehicle

onboard threat detection and targeting logic circuitry, an MCS operator will maintain contact with the vehicle continuously. Each of the sections will be able to control four UCAVs simultaneously.

The support segment (fig. 17) includes some very novel concepts. The UCAV is designed to be stored with its wings detached inside a climate-controlled and computerized storage container for years at a time. While in this container, engineers can communicate with the vehicle to update software, check vehicle status, and conduct simulations with controllers and other vehicles. The containers are designed so that six of them can be loaded onto a single C-17 for rapid transport to a theater of operations during contingencies and exercises. Boeing suggests the vehicles can be deployed to and operational within a theater in 24 hours. Appendix B lists many of the planned performance parameters for the UCAV program.

Contributions to a Strategy of Coercion

While the UCAV program does not answer any war-fighters' specific mission needs, it is designed to provide many useful qualities, capabilities, and characteristics to the theater commander. These qualities are very useful to the commander executing a strategy of coercion. The most obvious contribution of the UCAV is its ability to attack targets. With its onboard

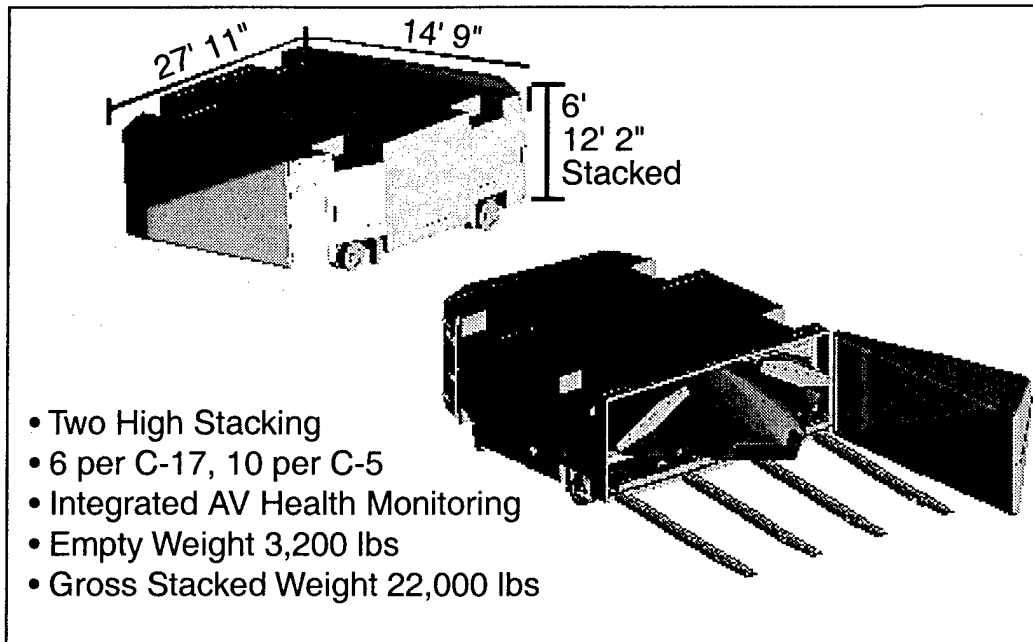

Source: Final Congressional Review (Washington, D.C.: Defense Advanced Research Programs Agency Tactical Technology Office, December 2000), 9.

Figure 17. UCAV Support Segment

high-resolution SAR, it can track impact points and precisely target its munitions. It can also locate impact points on its own with the radar, thus reducing dependence on other elements of the coercive force. With its radar and its stealthy characteristics, it can remain in the target area to assess, via radar, the weapon's impact and part of the tactical effect.

No one has mentioned any threat warning system or electronic countermeasures system aboard the UCAV, but its stealth qualities should reduce the need for these capabilities, giving it adequate self-protection qualities. With communications connectivity to the ground segment, the UCAV should be able to react to threats observed by other vehicles in the area—using their threat warning equipment for its own protection. While its fighter-type range gives the ground segment some separation from the conflict area, its most important defensive contribution is its ability to attack the most dangerous targets early in a conflict—minimizing the risk to other aircraft and helping to protect the total friendly force. No one has said how many UCAVs will be produced, but significant numbers of this aircraft or other very survivable weapon systems will be required early in a coercive scenario, especially against a well-equipped adversary.

With respect to credibility, UCAV offers significant capabilities that enhance the coercive strategy. It is clearly escalatory, assuming there is adequate parallel development of small smart munitions to enable the UCAV to achieve high kills-per-sortie ratios. Its unique support segment gives it

the ability to deploy to the theater quickly, with minimum preparation time and in large numbers. While the description of the program is impressive, such as the Global Hawk system, UCAV has yet to prove itself in combat. Until it proves itself to likely adversaries, it cannot maximize its value as a tool of coercion.

In a conflict with limited national interests at stake, the UCAV is particularly well suited for operations. Presumably, it will conform to ROEs once it has demonstrated an ability to operate alongside manned aircraft, and operators can maintain positive control over weapons release. Its stealth design obviously minimizes its vulnerability and remote piloting minimizes the likelihood of friendly casualties, but it also can help minimize other friendly casualties by attacking the most well-protected targets so that manned aircraft are not required to do it. This constitutes a total force protection capability.

Presumably, US allies will be as fond of the UCAV as they are of the UAV. The UCAV development is largely in the open, which relieves classification constraints that sometimes shield allies from new weapon systems. It offers a lower cost force employment option than traditional aircraft, meaning less prosperous nations will likely be able to afford it. It minimizes risks to friendly personnel but not at the expense of enemy casualties. Finally, it gives allies a cheap entry ticket into the US style of high-technology war fighting. For these reasons, the UCAV will likely be very coalition-friendly.

Like Global Hawk, the UCAV appears to offer the ability to send tacit communications by employing force precisely and on the commander's direction. The UCAV will rely on human weapon release authorization, thereby providing the theater commander with positive control over an armada of automatons. With the designed wideband communications, UCAVs can be dynamically retargeted, responding in very short notice to critical mission changes without replanning the mission. As with the Global Hawk, this ability increases the commander's options for escalating force employment, sending a tacit message to the adversary should the need arise. (See table 1. It also shows the completed contribution list for the UCAV.)

While the design information on the UCAV program is still general, indications available describe a weapon system that will contribute significantly to a coercive air strategy. Assuming the technologies to be used can demonstrate their efficacy in this vehicle, the UCAV system—while ambitious—promises to change greatly the way we think about employing force in a coercive strategy. It will probably reduce much of the debate on the level of interest involved in such a conflict, since the risk to friendly human life will be significantly reduced. It may also tend to increase the number of occasions the United States feels compelled to respond. With a lower threshold for employing coercive force, there may be more opportunities to do so. On the other hand, the reduced threat to US service members may correspondingly reduce the debate in Washington on the

needs of the services in this semiautonomous combat, also reducing the support they get.²⁶ In the end that might be a self-regulating mechanism: the less support Congress gives the military, the less frequently the nation is able to employ force and the more cries the United States hears from other nations for help.

The UCAV's broad descriptions also provide enough information so that we can use the framework to determine how it might be improved to provide even more utility to the commander in a coercive scenario. While UCAV is not slated to carry onboard electronic warning gear, by connecting directly to other platforms in the battle area that do carry this gear, it can get pseudo-warning of impending danger, increasing its own survivability while minimizing vehicle design changes that might diminish its stealth characteristics. With adequate broadband communications on board that can communicate directly with other aircraft, it can act as a communications relay for platforms on the far side of the battle area. Along those same lines, with longer communications links and possibly a relay between UCAV and its ground station, operators can position themselves even farther from the battlefield, increasing the system's protection.

Summary

This chapter applied the framework developed previously to two current developmental systems, the Global Hawk reconnaissance unmanned aerial vehicle and the UCAV. Using the means networks for Capability, Credibility, and Communication, this chapter assessed how these platforms might contribute to a coercive air strategy. As expected, both of these platforms can make critical contributions to such a strategy, but neither is a war winner in itself. As one might expect with new technology, neither vehicle has yet demonstrated the advertised capabilities in a combat scenario. Assuming the vehicles can deliver on these capabilities, and can prove themselves to likely adversaries, their value as coercive tools should increase quickly and measurably.

Perhaps more importantly, this chapter showed how to apply the framework to two unique systems. Starting with a description of each system and the generalized framework, one can methodically assess the contributions each system could make to a coercive strategy—showing what each offers the total force and how each can assist the theater commander in executing his strategy. After having painstakingly developed this framework, it may seem readily apparent how a commander should use vehicles such as these in a coercive strategy, but in general, it is not.

Operational war fighters have been engaged to assess the military utility of programs described in this chapter. This is a laudable change to traditional acquisition programs—which rely on dedicated test agencies—but it does not go far enough when new technologies are involved. Utility is best measured using a framework that includes not only the operational mechanisms of combat and conflict resolution but also the strategic and

political dimensions as well. The framework presented in this study does just that, working from the foundational national strategy statements and focusing them specifically on coercive air strategies.

Notes

1. DOD spends approximately \$600 million annually on UAVs and UAV-related programs. *Options for Enhancing the Department of Defense's Unmanned Aerial Vehicle Programs* (Washington, D.C.: Congressional Budget Office [CBO], September 1998), Preface, n.p., on-line, Internet, 28 March 2001, available from <http://www.cbo.gov/showdoc.cfm?index=917&sequence=0&from=7>.

2. William Wagner, *Lightning Bugs and other Reconnaissance Drones* (Fallbrook, Calif.: Armed Forces Journal International in cooperation with Aero Publishers, 1982), 6-8; and "V-75/SA-2 Guideline," *Federation of American Scientists Nuclear Forces Guide*, n.p., on-line, Internet, 28 March 2001, available from <http://www.fas.org/nuke/guide/russia/airdef/v-75.htm>.

3. Robert L. O'Connell asserts that historically there have been two dominant motivations for developing military innovations: counterresponse, as described here, and symmetrical response, driven by the desire to acquire the same weapon held by an adversary. See Robert L. O'Connell, *Of Arms and Men: A History of War, Weapons, and Aggression* (New York: Oxford University Press, 1989), 7.

4. Wagner, Foreword, n.p.

5. Harold Brown, "Alternative Reconnaissance System," 25 September 1961, as quoted in Wagner, 19-20.

6. Michael Armitage, *Unmanned Aircraft* (Oxford: Brassey's Defence Publishers Ltd., 1988), 78.

7. Wagner, Foreword, n.p.

8. Ibid.

9. Richard E. Boger Jr. offers an interesting synopsis of this argument: "All 'just war' theories of the past were based on the assumption that those engaged in the conflict would be making the ultimate sacrifice. They would be putting there [*sic*] lives on the line for [the] sake of some grand moral cause. Modern warfare is not like that. Our technology has made war too easy. There is some risk, yes, but by and large American or NATO lives have not been at risk in this conflict [Kosovo]. The war is being fought from the relative safety of the air with smart bombs. Is war too easy? Would Americans have supported or tolerated our involvement in the war in Yugoslavia if American lives were being lost on a daily basis? If we are not willing to make such sacrifices how do we justify the killing?" This argument would likely be magnified with the use of UCAV technology. See Richard E. Boger Jr., "The Morality of an Air War Examined," *St. Thomas Net Ministry*, May 1999, n.p., on-line, Internet, 18 April 2001, available from <http://www.stnm.org/meditation/may99.html>.

10. Armitage, 85.

11. *Options for Enhancing the Department of Defense's Unmanned Aerial Vehicle Programs* (Washington, D.C.: CBO, September 1998), chap. 1, n.p., on-line, Internet, 28 March 2001, available from <http://www.cbo.gov/showdoc.cfm?index=917&sequence=2&from=0>; and "The Gnat Tactical Endurance Aircraft," *General Atomics Aeronautical Systems*, home page, n.p., on-line, Internet, 31 March 2001, available from <http://www.ga.com/asi/aero.html>.

12. Jeffrey A. Drezner, Geoffrey Sommer, and Robert S. Leonard, *Innovative Management in the DARPA High Altitude Endurance Unmanned Aerial Vehicle Program: Phase II Experience* (Santa Monica, Calif.: RAND, 1999), 5-7; Michael R. Thirtle, Robert V. Johnson, and John L. Birkler, *The Predator ACTD: A Case Study for Transition Planning to the Formal Acquisition Process* (Santa Monica, Calif.: RAND, 1997), 5-9; and John Terino, "UAVs: A Defense Growth Area," *National Defense*, October 1992, 12-14.

13. CBO, *Options*, chap. 2, n.p.

14. CBO, *Options*, chap. 2, n.p., and Thirtle, Johnson, and Birkler, 12-13.

15. CBO, *Options*, chap. 2, n.p.

16. The HAE UAV program was designed specifically to satisfy the following Mission Needs Statements (MNS) approved by the Joint Requirements Oversight Council (JROC): Long Endurance Reconnaissance, Surveillance, and Target Acquisition (RSTA) Capability (JROCM-003090); Broad Area Coverage Imaging Capability (JROCM-037-95); and Assured Receipt of Imagery for Tactical Forces (JROCM-044-90). See ACC/DRR, "Background Paper on High Altitude Endurance Unmanned Aerial Vehicles," 6 February 1997, file K401.04-6, v. 4, document SD 79, Air Force Historical Research Agency (hereinafter cited as AFHRA), Maxwell AFB, Ala.; and *HAE UAV Joint Employment Concept of Operations* (hereinafter *HAE UAV Conops*) (Norfolk, Va.: Headquarters US Atlantic Command, 15 July 1998), iii, AFHRA file K401.01 v. 27, document SD D95.

17. "Darkstar Cancellation Decision Unanimous," *Aerospace Daily*, article 123514, 29 January 1999, AFHRA file K401.01 v.27, document SD 163.

18. The following discussion is adapted from *HAE UAV Conops*, chaps. 2 and 3; *Global Hawk C4ISP*, n.p., Section 2.0, "System Description"; and *Air Combat Command Concept of Operations for the Global Hawk Unmanned Aerial Vehicle* (Langley AFB, Va.: Headquarters AC2ISRC/C2U, August 2000).

19. J. D. R. Dixon, *UAV Employment in Kosovo: Lessons for the Operational Commander* (Newport, R.I.: Naval War College, 8 February 2000), 9-10.

20. Joseph J. Eash III, "Harnessing Technology for Coalition Warfare," *NATO Review* 48, Summer-Autumn 2000, 32-34.

21. *HAE UAV Conops*, A-10.

22. *New World Vistas: Air and Space Power for the 21st Century, Summary Volume* (Washington, D.C.: USAF Scientific Advisory Board, December 1995), n.p., on-line, Internet, 15 April 2001, available from <http://www.au.af.mil/au/awc/awcgate/vistas/vistas.htm>.

23. *Final Congressional Review* (Washington, D.C.: Defense Advanced Research Programs Agency Tactical Technology Office, December 2000), 2. Paper provided by DARPA TTO on CD-ROM, "final CR 120800.doc."

24. *Final Congressional Review*, 1-3.

25. The following discussion is adapted from *Final Congressional Review; Leahy, UCAV: Unmanned Combat Air Vehicle*, promotional brochure (St. Louis, Mo.: Boeing Co., 2001); and "Appendix A: UCAV System Capability Document," 9 March 1998, on-line, Internet, 8 February 2001, available from <http://www.darpa.mil/tto/ucav/ucavappen.html>.

26. Woodley argues that with reduced risk to the lives of constituents or their family members, Congress may tend to become less concerned over the use of military force and thus less supportive. R. Ross Woodley, *Unmanned Aerial Warfare: Strategic Help or Hindrance?* (Maxwell AFB, Ala.: School of Advanced Airpower Studies, May 2000), chap. 4.

Chapter 5

Conclusions

It is all the more necessary, therefore, that we develop a conceptual framework adequate not only as a base of departure for specific strategic plans but also as a means of weighing one plan against another.

—Bernard Brodie

In discerning operational requirements the real conceptual difficulties of military science occur. If there is not rigorous thinking at this level, neither technology nor money can help. With inadequate thinking about operational requirements, the best technology and the biggest budget in the world will only produce vast quantities of obsolete equipment; bigger and better resources for the wrong war.

—Sir Michael Howard

Both scholars above take pains to point out that we need a rigorously thought-out framework for assessing strategic plans and the technology that makes them possible. It appears we do not have such a framework yet—after a decade of strategy reviews, one of President Bush's first actions in office is to reassess exactly what the military needs to do and then determine how it should do it. The previous chapters in this study have attempted to apply the type of rigorous thinking Sir Michael Howard warned that we needed. Hopefully, this study has presented a conceptual framework that can help assess strategies and force structures in a manner that precludes the need to redesign the process every two years.

This chapter assesses the utility of the framework itself. It puts the framework into perspective, describing how this analysis tool compares to other tools of strategy and force structure assessment. It makes recommendations for the framework's continued use and development, and it finishes with a description of the larger value of the framework and the methodology used to develop it.

Framework in Perspective

Only by comparing the framework to other tools of assessment can we measure the utility of the framework itself. Traditionally, analysts use various means to assess each weapon system's military utility. As described in chapter 4, developers specifically designed the Global Hawk UAV program to meet recognized war-fighter needs as described in several mission needs statements (MNS). All new weapon system developments begin with the MNS, "a non-system-specific statement of operational capability need written in broad operational terms." A DOD component generates an MNS

with a four-step process that includes definition, documentation, validation, and approval. The entire process is lengthy and complicated, and it concludes with approval by a panel of service vice chiefs and an under-secretary or assistant secretary of defense. Following the MNS process, that same DOD component generates an operational requirements document (ORD) for major acquisition programs. The ORD is a "document containing operational performance requirements for a proposed concept or system." A weapon platform typically receives justification during the definition phase. That phase can include an analysis of alternatives study (AoA), an ACTD, or an ATD. Each of these attempts to assess the military utility of the weapon system.¹

The Global Hawk ACTD advertised itself as relying on war-fighter input to determine military utility. Indeed, that factor is a major differentiator between traditional acquisition and development programs and the ACTD. Determining what constitutes military utility, however, still appears somewhat vague.

The heart of an ACTD is the assessment of military utility by the warfighter . . . Military utility is defined as: (a) effectiveness in performing the mission, (b) suitability for use by the user, and (c) the overall impact the proposed capability has on the conflict or military operations . . . The third element of military utility, the overall impact on the conflict, highlights the difference between the ACTD exercises and traditional technical testing. The impact on the conflict is the result of not just the new technical capability, but also the gains which result from effective employment of that capability by the using unit, and of gains in other parts of the battle that result from higher performance of the using unit (e.g., domino effect). The overall impact is the integrated effect of all three factors.²

As an ACTD, Global Hawk was designed to provide reconnaissance in all types of conflict. Its designed missions include standoff surveillance, time-sensitive targeting and battle damage assessment, intelligence preparation of the battlespace, and increased situational awareness for the commander.³ All of these are worthy missions, and Global Hawk looks poised to fulfill each of them. Undoubtedly, all of these missions are essential at some point in almost any conflict, but none are linked to a specific strategic or political outcome. The assumption appears to be that these missions are always required; anytime we can do them better we should try to do so. But the mission descriptions never explain why these missions are important nor how Global Hawk fits into the US national strategy. Yet these are precisely the questions the current defense review is asking again. Unless we can justify improving these capabilities with technology, the highest-level decision makers are left to draw their own conclusions as to whether such programs have larger utility.

Although Global Hawk was the product of an ACTD, when the HAE UAV program transitioned to Air Combat Command (ACC) in 1998, ACC commissioned an AoA to assess the contribution of the platform in several standard scenarios. Its purpose was "to provide recommendations to senior leadership to guide Air Force force structure decisions to meet the Combat Air Force's (CAF), imagery intelligence (IMINT) requirements and

to provide DOD decision makers with the information necessary for making an HAE UAV acquisition decision. Additionally, the HAE UAV AoA will provide information to help build the Operational Requirements Document (ORD) for the program."⁴

In addition to Global Hawk, the AoA used future programmed friendly forces and threat assessments from several national agencies. Perhaps most importantly, it concentrated on two scenarios—Southwest Asia (the Arabian Gulf) and Korea. These two scenarios, which are typically used for campaign-level analysis, date from the 1993 Bottom Up Review.⁵ In reality, they represent the last two successfully prosecuted MTWs for the United States.

The AoA used "analytic calculations and computer models . . . where appropriate to determine the degree to which system performance characteristics contribute to meeting mission needs." It relied on four independent computer models plus spreadsheet analysis to assess force effectiveness. Analysts ran each of these models and fed the results of one into another as required to get a measure of the integrated effectiveness of the Global Hawk in the two scenarios used. At the end, analysts assessed Global Hawk based on its quantitative contribution to 42 measures of performance, ranging from "time to dynamically retask in flight" to "platform ground speed," that served as proxy measures for the MNS requirements. This AoA was programmed to last the better part of a year, consume many man-hours, computer processing operations, and thousands of dollars. Indeed, the quantitative analysis of military force structure and strategy is almost as complex as war itself. One would hope that all these quantitative measures (and some additional qualitative measures such as "interoperability" and "technical risk") add up to deliver a picture to the decision maker of the military utility of a weapon system such as Global Hawk.⁶ Not surprisingly, the analysis showed that the Global Hawk could add considerable utility at reasonable cost in the MTW scenarios.

While the framework presented here is not yet a substitute for this type of analysis, it can add a new dimension to assessing military utility that an AoA cannot. It allows a decision maker to assess a weapon system's contribution to a generalized strategy on a qualitative scale, using attributes the AoA measures by proxy quantitative values. It also allows the decision maker to see precisely how a weapon system might fall short in a given scenario and suggests ways to improve the weapon system's function. Where the quantitative analysis described by the AoA tends to mask results underneath an avalanche of data, the qualitative framework presented in this study presents it in a more intuitive manner as shown in table 1.

This framework allows simple analysis of more than two MTW scenarios. Although the particular framework this study presented applied specifically to coercive strategy scenarios, the methodology could also employ different theories to develop frameworks for other scenarios. An analytical framework for MTWs, for example, would likely include many of the same

attributes found in the coercive strategy framework; but those attributes must be traced directly to the national strategy documents and major war theories separately, just as was done for the coercive strategy. However, even if no other framework is developed, the one presented here adds a completely new scenario by which to assess military utility, a scenario with many attributes that are intrinsically difficult to quantify. Arguably, the coercion scenario is much more likely to occur than either of the two MTW scenarios used in the AoA.

As an analytical model, this framework can also help in quantitative as well as qualitative analysis. By setting some numerical scales for the attributes in this study's framework, an analyst can begin to make a quantitative assessment of the value of each weapon system. For example, "adequate force in time" may be represented by such measures as numbers of vehicles and time to deploy; "deliver weapons" may be represented by a measure for number of weapons delivered per sortie and circular error probable for those weapons. Certainly, many other attributes in the framework defy quantification. This, however, is no indictment of the framework but one of its strengths. Where traditional computer models disregard qualities that they cannot measure numerically, this analytical model includes them, forcing decision makers to recognize their existence and plan for them.

While the framework in this study cannot generate the reams of nuanced quantitative analysis that traditional computer models can, it can still provide insight into a weapon system's military utility. The AoA lists a few dozen measures of performance that it links directly to the MNSs Global Hawk supports. Joint Publication 1-02, *Joint Mission Essential Task List*, lists literally thousands of such measures, all of which will be "mission essential" at some point. But that is precisely the motivation for this framework. *When* will they be essential? Intuitively, as war fighters we know how, why, and when they will be essential. However, it is not enough for us to know it. We must be able to show the rest of the decision-making community how, why, and when. This framework does that. With the techniques used to develop this framework, it is easy to see why a particular characteristic or quality of a weapon system or a strategy supports a national military strategy or even a national security strategy.

Importantly, this analytical tool is also transportable and transferable. Any strategic planner can use this framework to guide his or her own analysis of strategy and systems; there is no need to depend on computer operators and operations researchers when the scenario changes or one element of the force structure is withdrawn. By looking at each of the attributes in the framework, any strategist or decision maker becomes his own analyst. Consider again the graphic representation of the analysis of the two unmanned systems in chapter 4, table 1. Were the coercive strategy to include only these two systems, it would clearly fall short. These two systems leave many of the essential attributes of a coercive strategy unsatisfied, a fact represented by side-by-side red entries in the table.

This type of analytical presentation makes it easier for the strategic planner and the commander to understand the shortfalls in his or her strategy and to plan how to overcome them. Not only is it a tool for analyzing a particular weapon system but it can also be used to assess what the aggregate force contributes to any particular scenario. In effect it becomes a tool to assess strategy. Certainly it is not a sufficient tool for such an assessment. Even if the entire table were green, there would be no guarantee of successful coercion. However, it serves well to indicate when the essential elements of coercion are present. That service is essential to creating a stable paradigm for assessing force structure and strategy for decision makers at all levels.

Perhaps most importantly, this framework and the methodology used to create it force the defense structure to come to terms with the missions it must perform and what it requires to perform those missions. While in retrospect the decision to build a reconnaissance UAV in the early 1960s might seem obvious now, it did not at the time—certainly not until the Vietnam War became a major operation. In large part, that may have been due to the national focus at the time. Preparing for war with the Soviet Union was the order of the day. Any capability that did not add directly to defeating that adversary suffered when it came time to fund new projects. Reconnaissance UAVs could not compete with thermonuclear weapons and their delivery systems.

Today the United States is still looking to overcome the cold war paradigm that has dogged it in the decade since the Soviet Union collapsed. Although in that time the military has fought with varying degrees of success in Somalia, Bosnia, and Kosovo, still it looks to MTW scenarios in Korea and Iraq to assess the contributions of new weapon systems. Perhaps this is because such conflicts are easier to quantify and easier to assess victory and defeat. By acknowledging that force structure and strategy must be prepared for new and more relevant missions like coercion missions that are admittedly difficult to measure quantitatively—DOD can move into a new era of military capability. By forcing analytical tools to link proposed capabilities directly to national strategic goals, DOD can take the first step in that direction.

Closing Thoughts

This study is not about decision analysis, although it spent much time developing the theory behind it. Using decision analysis techniques, chapter 2 linked the broad concepts in the national security strategy and the national military strategy to more narrowly focused considerations of coercion. It established the framework's legitimacy by relying on the accepted standards provided by those national-level documents. Consistent national guidance should provide a steady basis for designing future force structure and strategies. Although the new Bush administration will likely change these documents, this analysis still has lasting value. It provides

a decision analysis-based methodology for establishing an enduring framework from national level guidance. Even when that guidance changes, the same methodology applies. Furthermore, even with a new national strategy, the need to coerce adversaries will likely be a cornerstone of any administration's guidance.

Neither is this study about coercion, although it devoted chapter 3 to translating cold-war-era theories into requirements for the strategies and platforms that carry out coercion. That discussion was based on the premise that strategies and the weapon systems that effect them have unique qualities, characteristics, and capabilities (different from the capability that is one of the three Cs of coercion) that make them amenable to a coercion strategy. By analyzing each of the three Cs of coercion, the chapter built a detailed framework that laid out, in hierarchical and logical format, the attributes for each of these three elements. A given weapon system may possess many of these attributes; presumably the more attributes it possesses, the more it can contribute to a coercive strategy. While the attributes of the three Cs are probably not sufficient to achieve coercion by themselves, especially since coercion is fundamentally a strategic and political enterprise, they provide at least a minimal set of necessary attributes for strategies and forces that are applicable to any coercive scenario. Furthermore, since theory is rarely stagnant, the framework must be flexible enough to accommodate changes to the underlying theory of coercion. As new requirements for a coercive strategy are determined, as long as they do not replicate any of the requirements already in the framework, we can add them to the hierarchy without having to rebuild it from the beginning.

Finally, this study is not about unmanned aerial vehicles or unmanned combat air vehicles: although chapter 4 discussed in depth the capabilities and limitations of two such developmental unmanned systems, Global Hawk and UCAV. Looking at the qualities, characteristics, and capabilities of each of these systems in light of the framework, chapter 4 showed that both of them offer tremendous utility to the commander faced with a coercive scenario. Perhaps more importantly, this discussion showed how the framework could point to improvements and upgrades within each weapon system to make each more useful in a coercive strategy. By using this type of framework to assess a weapon system's military utility, especially early in the system's development, the resultant weapon system will better serve the strategy it supports. By using this type of framework to assess the military utility of new technologies, we can apply them prudently to enduring strategic requirements.

In the end, this study is about translating political goals and strategic theory into operational and tactical realities. The quotes at the beginning of this chapter called for "rigorous thinking" and a "conceptual framework" as we plan for the next war. This study provides a framework and a methodology for such strategic planning. These tools bridge the gap between civilian leaders in the United States who ultimately command

military forces and the uniformed members who attempt to organize, train, and equip those forces for contingency operations. By linking the art of coercion to the science of developing weapon systems, this framework provides a communications tool—a translator—between uniformed operators of military hardware and civilian users of military might. Only by linking these two can there ever be hope for stable guidance in the defense planning process.

Notes

1. Chairman of the Joint Chiefs of Staff Instruction (CJCSI) 3170.01A, *Requirements Generation System*, 10 August 1999, Enclosure C: Mission Need Statement Generation Process and Enclosure E: Operational Requirements Generation Process; n.p., on-line, Internet, 16 April 2001, available from http://web2.deskbook.osd.mil/htmlfiles/rlframe/REFLIB_Frame.asp?TOC=/htmlfiles/TOC/001pjtoc.htm&Doc=/reflib/mmulti/001pj/001pjdoc.htm&BMK=T2.
2. "ACTD Guidelines: Formulation, Selection, and Initiation", n.d., n.p., on-line, Internet, 4 April 2001, available from <http://www.acq.osd.mil/at/guidelns/formulat.htm>.
3. *HAE UAV Joint Employment Concept of Operations* (Norfolk, Va.: Headquarters US Atlantic Command, 15 July 1998), iii, Air Force Historical Research Agency (AFHRA) file K401.01 v. 27, document SD D95.
4. ACC/DR, "High Altitude Endurance Unmanned Aerial Vehicle (HAE UAV) Analysis of Alternatives (AoA) Study Plan," draft, 13 August 1998, n.p., par. 1.2, AFHRA file, K401.01 v. 27, document SD D115.
5. ACC AoA, par. 2.2.
6. *Ibid.*, par. 4.2.

Appendix A

Global Hawk Unmanned Aerial Vehicle System Characteristics

Wingspan	116 ft
Length	44 ft
Height	15 ft
Gross Take-off Weight	25,600 pounds
Payload	~2,000 pounds
Mission Duration	~24 hours on station at 3,000 nautical miles (NM)
Maximum Endurance	~40 hours
True Air Speed	300-400 knots
Loiter Altitude	50,000-65,000 feet
Operating Radius	3,000 NM
Ferry Range	~13,500 NM (unrefueled)
Fuel	JP-8 (USAF standard)
Navigation	Inertial Navigation System and Global Positioning System, coupled
Engine	Allison AE3007H
Survivability Measures	Threat warning, towed decoy, and limited electronic counter-measures (ECM) (onboard jammers, appliqués, expendable decoys)
Command and Control Links	Ultra High Frequency (UHF) Line of Sight (LOS) and Military Satellite Communications/Ku-band Satellite Communications/Common Data Link (CDL)
Sensors on Board	Synthetic Aperture Radar (SAR): 1 m search; 0.3 m spot, 108 NM max range Electro-Optical (EO): National Imagery Interpretation Rating Scale (NIIRS) 6.0* Infrared (IR): NIIRS 5.0* <i>Simultaneous Carriage and Operation (SAR and EO/IR)</i> Ground Moving Target Indicator: 4 knot Minimum Detectable Velocity (MDV) <20 meters
Circular error probable (CEP) for pointing sensors	
Sensor Coverage per Mission	40,000 NM ² search imagery, or 1,900 spot (2 km X 2 km) image frames
Sensor Data Transmission	Wideband Commercial Satellite: 1.5-50 Mbits/sec LOS wideband (CDL): 137 Mbits/sec
Ground Control	Maximum use of Government and Commercial Off-the-Shelf equipment (GOTS/COTS)
Data Exploitation	Existing: Joint Services Imagery Processing System (Navy) (JSIPS[N]), Tactical Exploitation Group (Marine Corps) (TEG), Joint Services Imagery Processing System (Air Force) (JSIPS[A]), Enhanced Tactical Radar Correlator (ETRAC)

	<p>Programmed: Defense Intelligence Agency (DIA), Joint Intelligence Centers (JIC), Contingency Airborne Reconnaissance System (CARS), Modernized Imagery Exploitation System (MIES), Tactical Exploitation System (TES), UAV Exploitation System (UES), all Common Imagery Ground/Surface System (CIGSS) compatible</p>
--	---

Source: Data provided by *HAE UAV Joint Employment Concept of Operations* (Norfolk, Va.: Headquarters, US Atlantic Command Director of Operations [USACOM J-3], 15 July 1998), 2-3, 2-6, 2-11; and A-11 and *Air Combat Command Concept of Operations for the Global Hawk Unmanned Aerial Vehicle* (Langley AFB, Va.: Headquarters AC2ISRC/C2U, August 2000).

*NIIRS 6.0 Criteria for EO systems include the ability to "distinguish between models of small/medium helicopters" and "identify the spare tire on a medium sized truck." NIIRS 5.0 Criteria for IR systems include the ability to "distinguish between single-tail and twin-tailed fighters" and "detect armored vehicles in a revetment." See R. C. Olsen, *Remote Sensing from Air and Space*, Physics 3052 Course Text (Monterey, Calif.: Naval Postgraduate School, 9 September 2000), n.p., appendix, on-line, Internet, available from http://www.physics.nps.navy.mil/ph_3052.htm.

Appendix B

Unmanned Air Combat Vehicle System Characteristics

Air Vehicle

Length	27 ft
Wing Span	34 ft
Height	7 ft
Weight (dry)	8,000 lb
Propulsion	Single business jet class engine
Speed	High subsonic
Ceiling	Medium to high altitude
Range	500–1,000 mile radius
Weapons bay	Internal
Payload	1,000–3,000 lb
Weapons	Variety of smart weapons
Structure	Al substructure/composite skins
Subsystems	All electric
Communications	Satellite/Line-of-sight

Mission Control

Dynamic mission planning and replanning
Decision aids for planning and execution
Single operator manages multiple vehicles
Common operating picture on board and off board
Robust and secure communications
Dynamic distributed management of air vehicles (for combat as well as safe operations)
Task allocation by phase of mission

Supportability

Operator training using realistic simulations
Storage up to 10 years in containers - allowing external maintenance monitoring and software upgrades.
Global deployment in 24 hours
Flexible transport or self-deployment
- (six aircraft per C-17; 10 per C-5)
- Reassembly (from containers) in less than 75 minutes
Flexible basing locations
Operations/maintenance easily integrated with manned aircraft wing/squadron

Source: Data from *Final Congressional Review* (Washington, D.C.: Defense Advanced Research Programs Agency Tactical Technology Office, December 2000). Study provided by DARPA TTO on CD-ROM, "final CR 120800.doc."