

AD _____

Award Number: DAMD17-00-1-0377

TITLE: FAK Signaling in the Acquisition of a Cancerous Phenotype
in Breast Epithelial Cells

PRINCIPAL INVESTIGATOR: Veronica Gabarra-Niecko
Michael D. Schaller, Ph.D.

CONTRACTING ORGANIZATION: University of North Carolina
at Chapel Hill
Chapel Hill, North Carolina 27599-1350

REPORT DATE: April 2002

TYPE OF REPORT: Annual Summary

PREPARED FOR: U.S. Army Medical Research and Materiel Command
Fort Detrick, Maryland 21702-5012

DISTRIBUTION STATEMENT: Approved for Public Release;
Distribution Unlimited

The views, opinions and/or findings contained in this report are those of the author(s) and should not be construed as an official Department of the Army position, policy or decision unless so designated by other documentation.

20020913 038

REPORT DOCUMENTATION PAGE

Form Approved
OMB No. 074-0188

Public reporting burden for this collection of information is estimated to average 1 hour per response, including the time for reviewing instructions, searching existing data sources, gathering and maintaining the data needed, and completing and reviewing this collection of information. Send comments regarding this burden estimate or any other aspect of this collection of information, including suggestions for reducing this burden to Washington Headquarters Services, Directorate for Information Operations and Reports, 1215 Jefferson Davis Highway, Suite 1204, Arlington, VA 22202-4302, and to the Office of Management and Budget, Paperwork Reduction Project (0704-0188), Washington, DC 20503

1. AGENCY USE ONLY (Leave blank)		2. REPORT DATE April 2002	3. REPORT TYPE AND DATES COVERED Annual Summary (1 Apr 01 - 31 Mar 02)	
4. TITLE AND SUBTITLE FAK Signaling in the Acquisition of a Cancerous Phenotype in Breast Epithelial Cells			5. FUNDING NUMBERS DAMD17-00-1-0377	
6. AUTHOR(S) Veronica Gabarra-Niecko Michael D. Schaller, Ph.D.				
7. PERFORMING ORGANIZATION NAME(S) AND ADDRESS(ES) University of North Carolina at Chapel Hill Chapel Hill, NC 27599-1350 E-Mail:vgniecko@med.unc.edu			8. PERFORMING ORGANIZATION REPORT NUMBER	
9. SPONSORING / MONITORING AGENCY NAME(S) AND ADDRESS(ES) U.S. Army Medical Research and Materiel Command Fort Detrick, Maryland 21702-5012			10. SPONSORING / MONITORING AGENCY REPORT NUMBER	
11. SUPPLEMENTARY NOTES Report contains color.				
12a. DISTRIBUTION / AVAILABILITY STATEMENT Approved for public release; distribution unlimited				12b. DISTRIBUTION CODE
13. Abstract (Maximum 200 Words) (abstract should contain no proprietary or confidential information) Focal adhesion kinase (FAK) is a non-receptor tyrosine kinase that transduces extracellular signals to the inside of the cell. FAK mediates normal cellular processes including motility, survival, and cell cycle regulation. FAK is overexpressed in a variety of tumors. Wild type FAK and an activated mutant of FAK, SuperFAK, were expressed in the normal breast epithelial cell line, MCF10A, in order to enhance FAK signaling. The elevation of FAK signaling alone had no effect in the adhesion independent growth of the MCF10A cells. The addition of high levels of epidermal growth factor to FAK and SuperFAK expressing MCF10As lead to the formation of soft agar colonies. In the second model system, FAK was inhibited in a breast cancer epithelial cell line, T47D, using FRNK, a dominant negative variant of FAK. When FRNK was expressed in the T47D cancer cells, a loss in their adhesion independent growth was observed. The underlying mechanisms for some of the observed effects are being investigated. Similar effect of FAK signaling on tumorigenesis <i>in vivo</i> is apparent. The data indicates the potential importance of aberrant FAK signaling as a cause for some of the phenotypic changes that occur when a cell becomes oncogenically transformed.				
14. SUBJECT TERMS Focal adhesion kinase, SuperFAK, FRNK, breast cancer				15. NUMBER OF PAGES 73
				16. PRICE CODE
17. SECURITY CLASSIFICATION OF REPORT Unclassified	18. SECURITY CLASSIFICATION OF THIS PAGE Unclassified	19. SECURITY CLASSIFICATION OF ABSTRACT Unclassified	20. LIMITATION OF ABSTRACT Unlimited	

Table of Contents

Introduction.....	3
Body.....	3-6
Key Research Accomplishments.....	6
Reportable Outcomes.....	6-7
Conclusions.....	7
References.....	8
Appendices.....	9

INTRODUCTION

Focal Adhesion Kinase (FAK) is a non-receptor tyrosine kinase first identified as a highly phosphorylated protein in Src transformed cells^{1,2}. This observation suggested a potential role for FAK in cell transformation. FAK is known to transduce extracellular signals that are received by the integrins on the surface of the cell. In this manner, FAK can mediate a number of normal cellular processes including motility, cell survival, and cell cycle regulation³⁻⁷. The deregulation of these cellular processes is characteristic of transformation and cancer. Thus, the aberration of FAK signaling is hypothesized to contribute to the process of oncogenic transformation. Most importantly, FAK is overexpressed in a number of human tumors, including breast cancer, suggesting that FAK signaling may play a role in the development and/or progression of this disease^{8,9}. The purpose of this study was to determine the role of FAK signaling in the acquisition of cancer phenotypes in breast cancer epithelial cells. For this purpose, FAK signaling was enhanced in normal breast epithelial cells, MCF10A, by overexpression of wild type or an activated mutant of FAK, SuperFAK (APPENDIX B – Manuscript). In addition, FAK was inhibited in a breast cancer epithelial cell line, T47D, by expressing a dominant negative FAK variant, FRNK¹⁰. Biochemical and biological studies were performed to determine successful activation or inhibition of FAK signals. The normal and breast cancer cells expressing FAK, SuperFAK or FRNK, were examined for changes in their biological properties related to cancer, including growth in soft agar, invasion and formation of tumors in nude mice.

BODY

In order to increase FAK signaling in normal breast epithelial cells, we expressed wild type FAK and SuperFAK, an activated mutant of FAK (Appendix B – Manuscript) in MCF10A cells. SuperFAK exhibits elevated *in vitro* catalytic activity relative to wild type FAK (Appendix B – Manuscript, Fig. 2, 4) resulting in an increased ability to phosphorylate FAK substrates (Appendix B – Manuscript, Fig. 3). Furthermore, SuperFAK is able to increase the motility of T47D cells to a greater degree than wild type FAK (Appendix B – Manuscript, Fig. 10). Thus, SuperFAK is a valuable tool that can be used to increase FAK signaling. To achieve FAK and/or SuperFAK expression in MCF10A cells a mammalian retroviral vector was used and a population of successfully infected MCF10A was isolated (Appendix A – Fig. 1A). The expression of FAK and SuperFAK was determined by Western blotting of MCF10A lysates with a polyclonal FAK antibody (APPENDIX A – Fig. 1B). Initially only low levels of exogenous protein were expressed. By titrating the amount of DNA used to transfect the packaging cell lines that produce the retrovirus and the amount of virus used in the infection a significant amount of FAK and SuperFAK was successfully expressed in MCF10A (Appendix A – Fig. 1B and C).

To decrease FAK signaling in the breast cancer epithelial cells, T47D, a naturally occurring dominant negative of FAK, FRNK, was introduced in these cells¹⁰⁻¹². In addition, a mutant of FRNK, HK, that can no longer act as a dominant negative was used as a negative control¹³. Furthermore, wild type FAK and SuperFAK were also expressed in T47D to investigate the effect of increased FAK signaling in the T47D breast cancer cells (Appendix B – Manuscript, Fig. 10). These constructs were previously cloned into

an avian replication competent retroviral vector, RCAS type A, for expression and characterization in chicken embryo fibroblasts. Upon successful expression of the constructs in chicken embryo fibroblasts, the cells will produce and shed retrovirus encoding the constructs of interest. These avian retroviruses were collected and used to infect avian cells, which express the avian retroviral receptor, Tva, or to infect T47D cells that stably express the Tva receptor (T47D/Tva) (Appendix A – Fig. 2A). Successful expression of FAK and SuperFAK has already been demonstrated (Appendix B – Manuscript. Fig. 10). In addition, successful expression of FRNK and HK has been achieved in the T47D/Tva cells (Appendix A – Fig. 2B).

The next step is to verify that FAK, SuperFAK, and FRNK behaved as expected when expressed in the breast epithelial cells. A number of biochemical and biological assays were proposed for this purpose. Previously, we showed that expression of FAK or SuperFAK in MCF10A cells, slightly increased the cellular phosphotyrosine content, most notably of the FAK substrate, paxillin. We have recently isolated populations of MCF10A expressing higher levels of FAK and SuperFAK (APPENDIX A – Fig.1C). Phosphotyrosine changes will be examined in these cells by Western blotting. Furthermore, levels of phosphotyrosine in response to a physiological activator of FAK signaling, i.e. collagen, fibronectin, will be examined.

Previously, we demonstrated that SuperFAK immunoprecipitated from T47D/Tva expressors had a higher *in vitro* kinase activity than wild type FAK. In order to verify that FAK, SuperFAK and FRNK were increasing or inhibiting downstream FAK signaling, the level of phosphorylation of FAK effector proteins i.e. paxillin, was analyzed by immunoprecipitation followed by phosphotyrosine Western blotting. No major differences in the phosphotyrosine level of paxillin were detected in cultured T47D/Tva cells expressing FAK, SuperFAK or FRNK. To specifically examine tyrosine phosphorylation in response to a physiological stimulus that regulates FAK, T47D expressors were plated on different extracellular matrices. Although fibronectin was not an effective substrate, T47D cells adhered to collagen coated plates. After 1 hr on collagen, the T47D cells were lysed. Paxillin was immunoprecipitated and the immune complex was Western blotted with a phosphotyrosine antibody. As expected, FRNK inhibited paxillin phosphorylation following adhesion to collagen (Appendix A – Fig. 3). Further biochemical characterization of T47D cells expressing FAK and SuperFAK is underway, to determine if their expression leads to increased downstream phosphorylation in response to physiological stimuli.

FAK is a known mediator of motility^{3,14}. Thus, to determine if increasing or inhibiting FAK signaling altered the ability of T47D cells to migrate, the effects of FAK, SuperFAK and FRNK expression on T47D motility was analyzed using a transwell assay system (Appendix A – Fig. 4A). The underside of the porous membrane in the transwell was coated with collagen. T47D cells were added to the top chamber and allowed to migrate for 20-22 hrs. The number of cells that had reached the underside of the membrane was scored as an indication of haptotactic motility. It was previously demonstrated that expression of wild type FAK increased T47D/Tva motility, and SuperFAK increased motility to higher levels (Appendix B – Manuscript. Fig. 10). In addition, we further demonstrate that FRNK expression can inhibit T47D/Tva motility

(Appendix A – Fig. 4B). These observations indicated that FAK, SuperFAK, and FRNK expression in breast epithelial cells alter biochemical and biological FAK signaling.

Finally, upon enhancement or inhibition of FAK signaling, it was proposed that the MCF10A and T47D would be monitored for acquisition or loss of cancer phenotypes to elucidate the role of FAK signaling in oncogenic transformation. One characteristic phenotype of cancer cells is their ability to grow without the need to adhere to a physiological substrate. Soft agar assays were utilized to measure the ability of the MCF10A and T47D cells to grow in an adhesion independent manner. Initial experiments demonstrated the MCF10A alone or expressing either FAK or SuperFAK was unable to form colonies in soft agar (APPENDIX A – Fig. 5; top panels). However, upon the addition of high levels of epidermal growth factor, colonies formed (APPENDIX A – Fig. 5). Interestingly, more colonies were formed by FAK expressing MCF10A (APPENDIX A – Fig. 5B). A strong link between the EGFR family of receptors and breast cancer has been established. Our preliminary observations suggest a collaborative role of FAK signaling with EGF in the acquisition and/or enhancement of cancer phenotypes. However, further experimentation is required to confirm these results.

The effect of inhibition of FAK signaling on T47D soft agar colony formation was shown before. FRNK expression in T47D cells is able to decrease the number of colonies forming in an agar matrix by about 50% (APPENDIX – Fig. 6A,B). In order to demonstrate that the effect of FRNK was specific to its dominant negative ability, a FRNK mutant, HK, was utilized. Although HK can localize to focal adhesions and can bind paxillin, it is unable to function as a dominant negative mutant¹³. Expression of HK in T47D cells has no effect on their ability to form colonies (APPENDIX A – FIG 6A). These observations demonstrate that the effect of FRNK on T47D adhesion independent growth is specific to its ability to act as a dominant negative mutant for FAK. The data collected suggests a role for FAK signaling in acquisition of adhesion independent growth, a hallmark of oncogenic transformation.

It was noted that some colonies still appeared when T47D FRNK expressors were grown in soft agar. In order to understand the reason for the appearance of these colonies, we attempted to isolate and culture colonies from the agar matrix. Thus far, 3 colonies have been isolated and grown. Their level of FRNK expression was analyzed by Western blotting using a polyclonal FAK antibody. Either low levels or no FRNK expression was detected (APPENDIX A – 6C). Thus, it seems likely that growth in soft agar selected for low FRNK expression or loss of FRNK expression.

The mechanism(s) by which FRNK inhibits the growth of T47D cells in soft agar is being assessed. FAK mediates a survival signal activated by adhesion³⁻⁵. Thus, FRNK could be inhibiting the survival signals in the T47D cells and cause them to undergo apoptosis. If this were true, we would expect a selection against the T47D FRNK expressors. However, it was shown that FRNK expression in T47D was perfectly stable for at least 9 weeks after infection. Furthermore, there are no changes in apoptotic cell numbers, measured by TUNEL staining, between T47D and T47D FRNK cells kept in culture or in held in suspension for 24 and 48 hrs. Thus, the effect of FRNK on adhesion independent growth is not due to inhibition of a survival signal. FAK has been proposed to have a positive effect on the G1 to S transition of the cell cycle. Thus, FRNK could be

inhibiting T47D cell growth in the soft agar assay. Growth curves will be used to study the effect to FAK, SuperFAK as well as FRNK on the cell cycle.

In order to evaluate the effect of FAK, SuperFAK, and FRNK on the tumorigenicity of T47D, cells expressing the proteins of interested were injected subcutaneously into nude mice. The formation of tumors will be monitored for a total of 6-8 weeks. Initial observations (week 3) suggest a potentiation of tumor growth by SuperFAK and a potential inhibition in tumor growth of T47D FRNK cells (APPENDIX A – Fig. 7).

KEY RESEARCH ACCOMPLISHMENTS

Task 1

- Expression of FAK and SuperFAK in MCF10A cells.
- Expression of FAK, SuperFAK and FRNK in T47D/Tva cells.

Task 2

- Increased of paxillin phosphorylation by FAK in MCF10A cells.
- Decreased paxillin phosphorylation by FRNK in T47D/Tva cells.
- Increased motility of T47D/Tva cells expressing FAK or SuperFAK.
- Decreased motility of T47D/Tva cells expressing FRNK.

Task 3

- Increased soft agar colony formation of MCF10A cells expressing FAK.
- Decreased soft agar colony formation of T47D/Tva cells expressing FRNK.
- Increased tumor growth of T47D/Tva expressing SuperFAK *in vivo* (in progress).
- Decreased tumor growth of T47D/Tva expressing FRNK *in vivo* (in progress).

REPORTABLE OUTCOMES

APPENDIX A

Data figures and legends

APPENDIX B

Paper “In Press” in the Biochemical Journal:

“Characterization of a Hyperactive Mutant of Focal Adhesion Kinase: SuperFAK”

Veronica Gabarra-Niecko, Patricia J. Keely, Michael D. Schaller.

(In Press)

APPENDIX C

Joint UNC-CH and Duke Cell and Developmental Biology Retreat

“Role of FAK Signaling in the Acquisition of Cancer Phenotypes in Breast Epithelial Cells”

Southern Pines, NC

April 5-7, 2002

(Poster)

APPENDIX D

Experimental Biology Meeting: “Translating the Genome”

New Orleans, LO

April 20-24, 2002

“Molecular and structural analysis of the focal adhesion kinase”

M.D. Schaller, V. Gabarra, M. King-Brantley, G. Gao, K. Prutzman and S. L. Campbell
(Published Abstract; presentation)

Cell lines:

MCF10 cells expressing FAK and SuperFAK.

T47D/Tva cells expressing FAK, SuperFAK, FRNK.

CONCLUSIONS

The manuscript “in press” demonstrates the successful construction of an activated mutant of FAK, SuperFAK. Successful expression of FAK and SuperFAK in MCF10A has been achieved and further biochemical and biological characterization is currently under investigation. SuperFAK was previously shown to have high *in vitro* catalytic activity relative to wild type FAK in T47D/Tva cells. Furthermore, FAK and SuperFAK seem to increase paxillin phosphorylation. Conversely, FRNK can decrease paxillin phosphorylation. T47D/Tva motility is increased upon expression of FAK and SuperFAK. FRNK can in turn inhibit T47D motility. Thus, FAK, SuperFAK and FRNK are valuable tools to study the role of FAK signaling in the acquisition of cancer phenotypes in breast epithelial cells. Expression of FAK in MCF10A cells increases their ability to form colonies in soft agar in the presence of high levels of EGF. These observations suggest a role for increased FAK signaling as a cooperative signal that can lead to the acquisition of adhesion independent growth. The expression of FRNK in T47D/Tva causes a decrease in the ability of these cells to form colonies in soft agar. The mechanism through which FRNK inhibits colony formation in the T47D cells is underway. Adhesion independent growth is one of the phenotypic hallmarks of oncogenic transformation. Furthermore, in preliminary *in vivo* studies, SuperFAK increases the tumor growth of T47D. In turn, FRNK seems to inhibit the growth of T47D/Tva tumors in mice. Additional studies will investigate the role of FAK signaling in the acquisition of other cancer phenotypes. The accumulating data in these studies suggest an important role for increased FAK signaling in the acquisition of adhesion independent growth and *in vivo* tumorigenesis of breast epithelial cells. These observations identify FAK as a valuable target for breast cancer therapy.

REFERENCES

1. S. B. Kanner, A. B. Reynolds, R. R. Vines, J. T. Parsons, *Proc.Natl.Acad.Sci.U.S.A* 87, 3328-3332 (1990).
2. M. D. Schaller et al., *Proc.Natl.Acad.Sci.U.S.A* 89, 5192-5196 (1992).
3. A. P. Gilmore and L. H. Romer, *Mol.Biol.Cell* 7, 1209-1224 (1996).
4. J. E. Hungerford, M. T. Compton, M. L. Matter, B. G. Hoffstrom, C. A. Otey, *J.Cell Biol.* 135, 1383-1390 (1996).
5. S. M. Frisch, K. Vuori, E. Ruoslahti, P. Y. Chan-Hui, *J.Cell Biol.* 134, 793-799 (1996).
6. L. H. Romer, N. McLean, C. E. Turner, K. Burridge, *Mol.Biol.Cell* 5, 349-361 (1994).
7. J. H. Zhao, H. Reiske, J. L. Guan, *J.Cell Biol.* 143, 1997-2008 (1998).
8. L. V. Owens et al., *Cancer Res.* 55, 2752-2755 (1995).
9. L. V. Owens et al., *Ann.Surg.Oncol.* 3, 100-105 (1996).
10. A. Richardson, R. K. Malik, J. D. Hildebrand, J. T. Parsons, *Mol.Cell Biol.* 17, 6906-6914 (1997).
11. M. D. Schaller, C. A. Borgman, J. T. Parsons, *Mol.Cell Biol.* 13, 785-791 (1993).
12. A. Richardson and J. T. Parsons, *Bioessays* 17, 229-236 (1995).
13. M. A. Cooley, J. M. Broome, C. Ohngemach, L. H. Romer, M. D. Schaller, *Mol.Biol.Cell* 11, 3247-3263 (2000).
14. L. A. Cary, J. F. Chang, J. L. Guan, *J.Cell Sci.* 109 (Pt 7), 1787-1794 (1996).

APPENDICES

APPENDIX A

2002 Annual Summary Report Figures and Legends

Figure 1: Expression in MCF10A, Normal immortalized Breast Epithelial Cells

A. A packaging cell line was used to produce retroviruses encoding FAK and SuperFAK. The MCF10A cells were infected with the retrovirus to achieve expression of FAK and/or SuperFAK. A population of successfully infected cells was isolated. B. To monitor for FAK and SuperFAK expression, whole cell lysates (25 ml) of MCF10A infected with the retroviruses were Western blotted with a polyclonal FAK antibody, BC4. C. Same as (A), higher amounts of virus were used.

Figure 2: Expression of FAK and FRNK in T47D/Tva Breast Carcinoma Epithelial Cells

A. T47D cells stably expressing the avian retroviral receptor (Tva) were infected with the avian retrovirus produced by chicken embryo fibroblasts expressing wild type FAK or FRNK. B. Fourteen days after infection, whole cell lysates (25 mg) were analyzed by SDS-PAGE and Western blotted with a FAK polyclonal antibody, BC4.

Figure 3: FRNK decreases Paxillin Phosphorylation in T47D cells.

Paxillin was immunoprecipitated from lysates of FRNK expressing T47D or control T47D cells (500 mg). Cells were held in suspension for 45 minutes (SU) or plated on collagen-coated dishes (COL) prior to lysis. The immune complexes were Western blotted with a phosphotyrosine antibody, RC20 (top panel). The nitrocellulose membranes were stripped and re-probed for paxillin to ensure equal amounts of protein were analyzed (bottom panel).

Figure 4: Motility of T47D/Tva cells

A. T47D/Tva cells expressing wild type FAK, SuperFAK or FRNK were allowed to migrate through collagen I coated transwell membranes for 20 hrs. The cells that had migrated to the underside of the membrane were stained and counted. B. The average fold change in motility is shown.

Figure 5: Adhesion Independent Growth of MCF10As

MCF10A cells expressing wild type FAK or SuperFAK were suspended in a soft agar matrix for about 30 days. The colonies formed were photographed (top panel) and counted (bottom panel).

Figure 6: Adhesion Independent Growth of T47Ds

T47D/Tva cells expressing wild type FAK or the dominant negative FAK mutant, FRNK, were suspended in a soft agar matrix for two weeks. The colonies formed were photographed (top panel) and counted (bottom panel).

Figure 7: T47D in vivo tumorigenesis.

T47D/Tva cells (1.2×10^7) expressing empty vector (mock), SuperFAK or FRNK were injected subcutaneously in 8 week old nude mice. The pictures were taken 18 days after cell injections. At this time, the average volume was mock: 30.7 mm³; SuperFAK: 42.9 mm³; FRNK: 27.1 mm³.

Figure 1

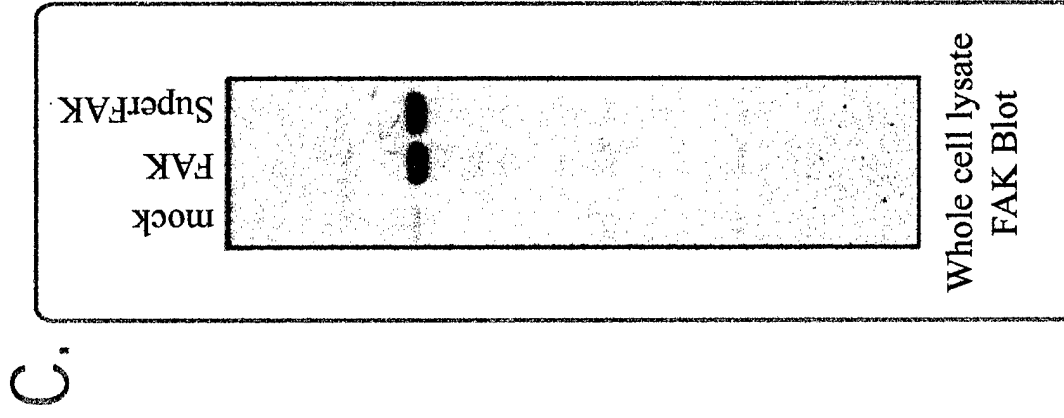
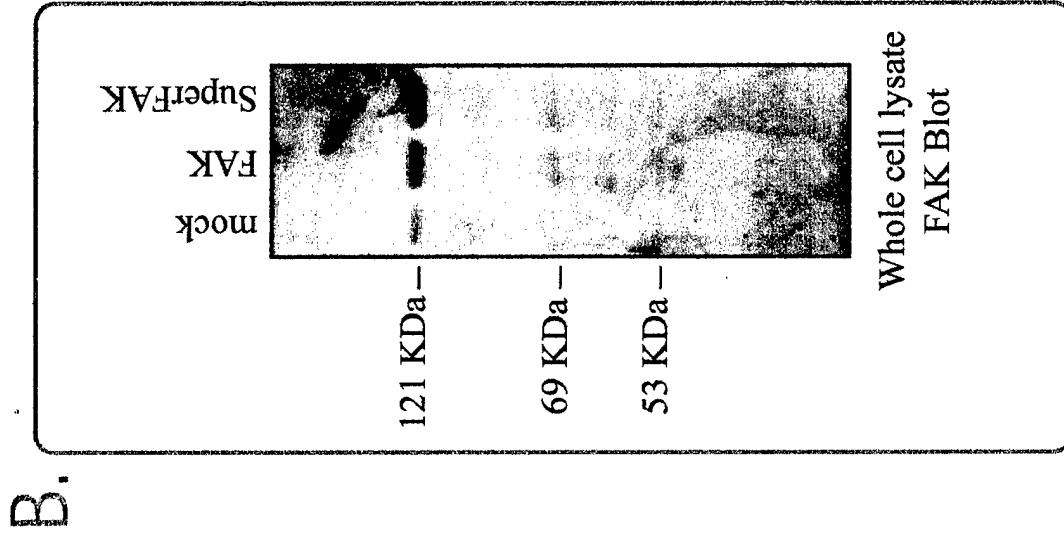
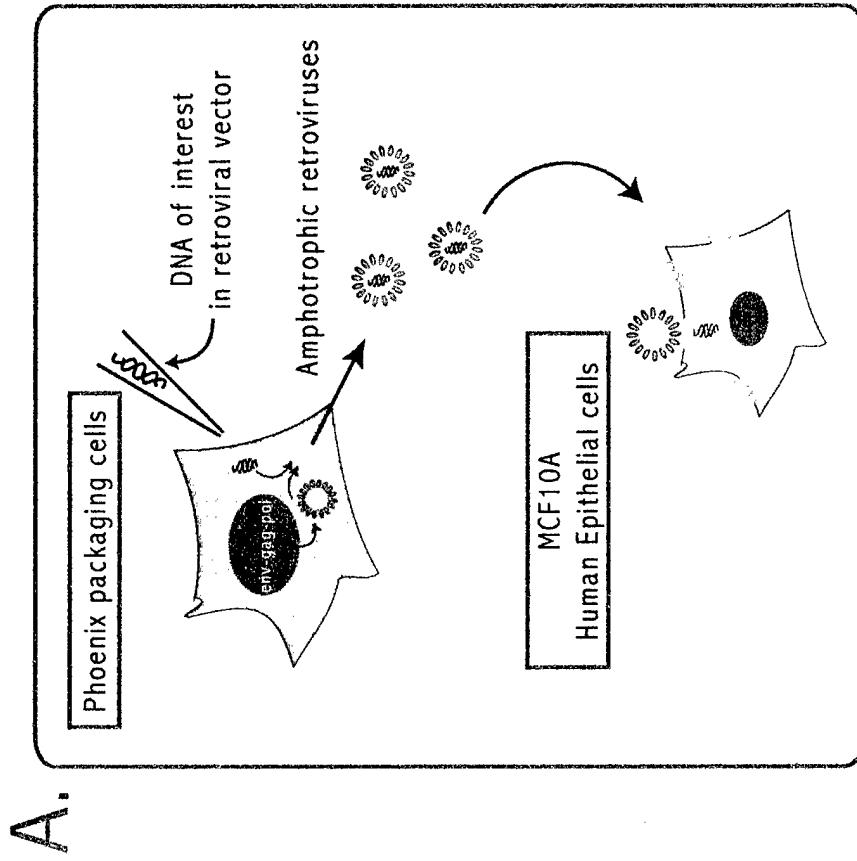

Figure 2

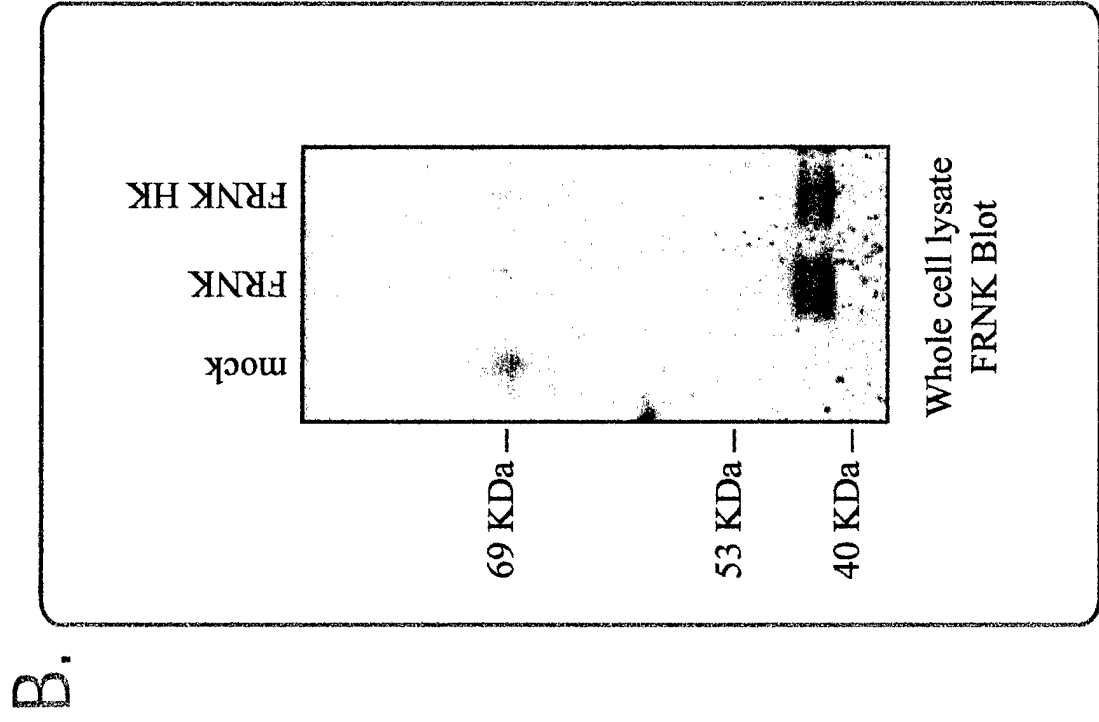
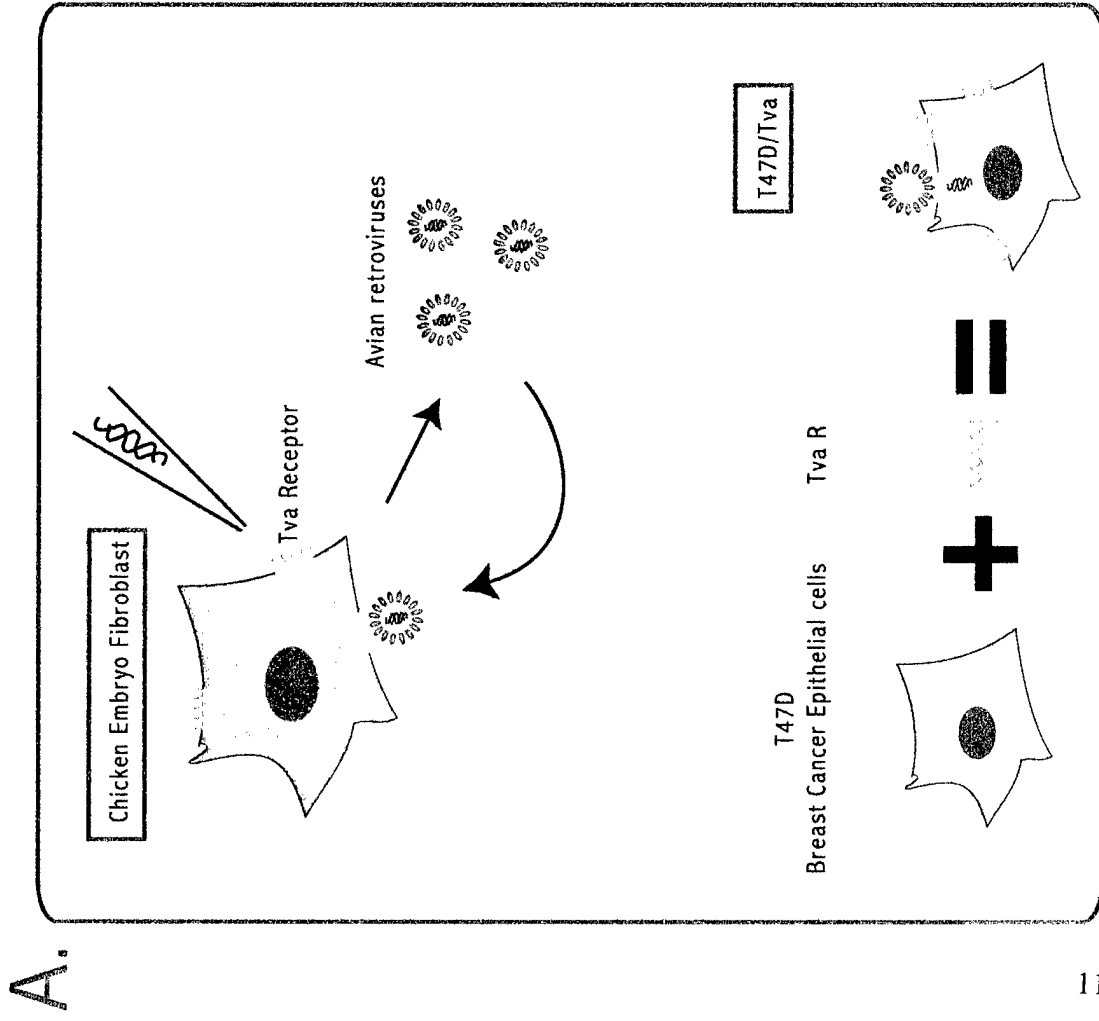

Figure 3

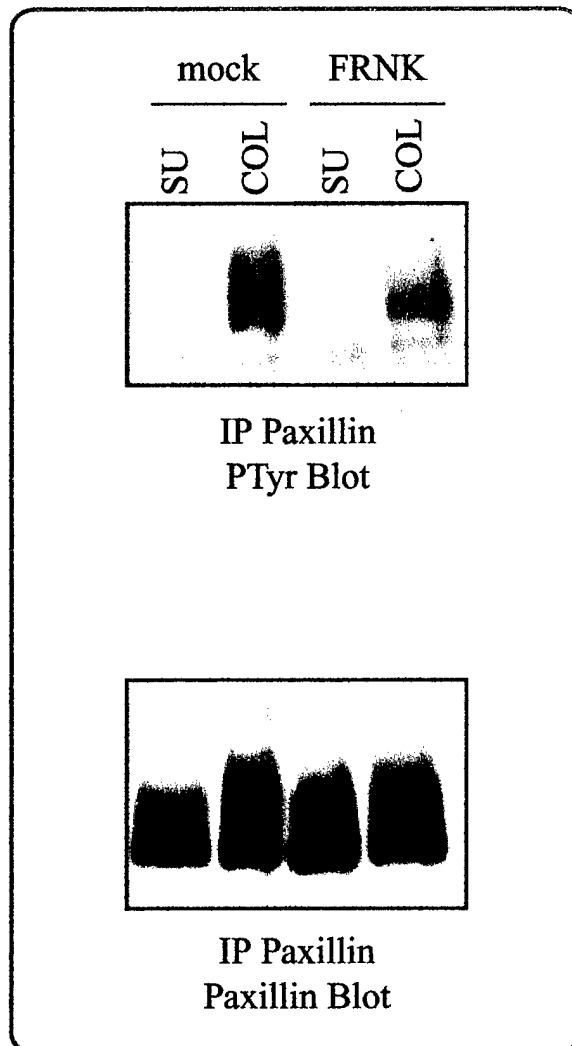
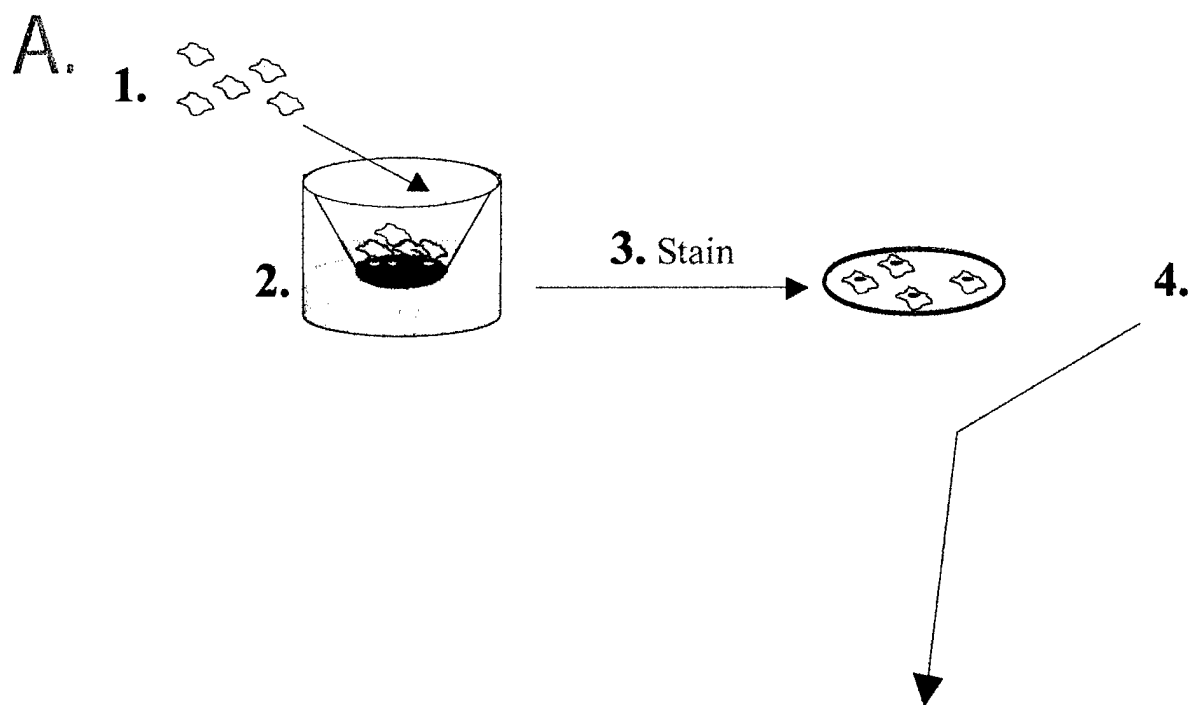

Figure 4



B.

T47D MOTILITY

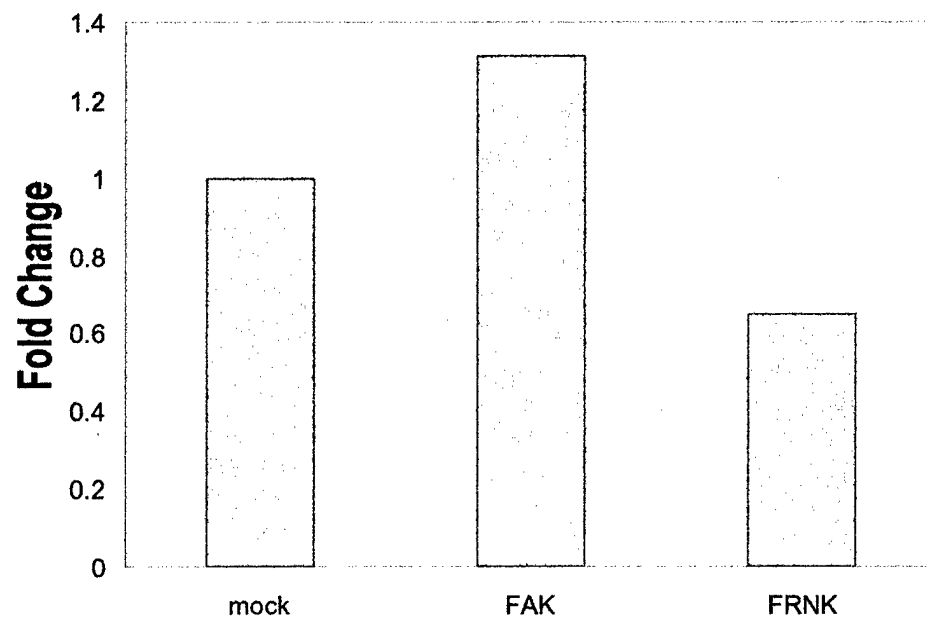
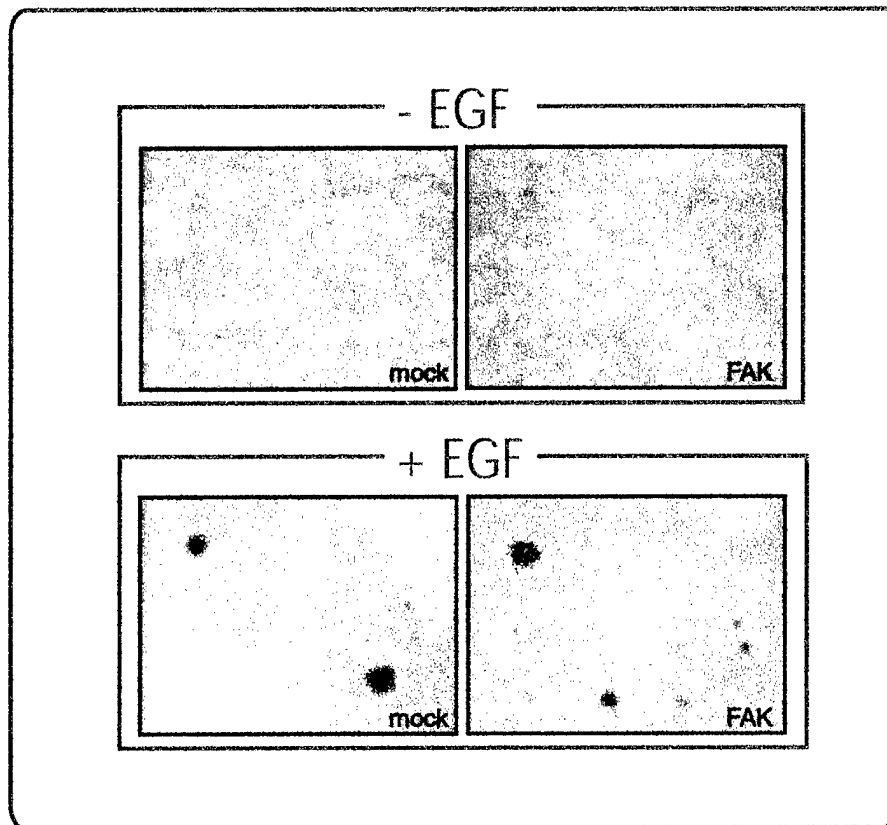

Figure 5

A.



B.

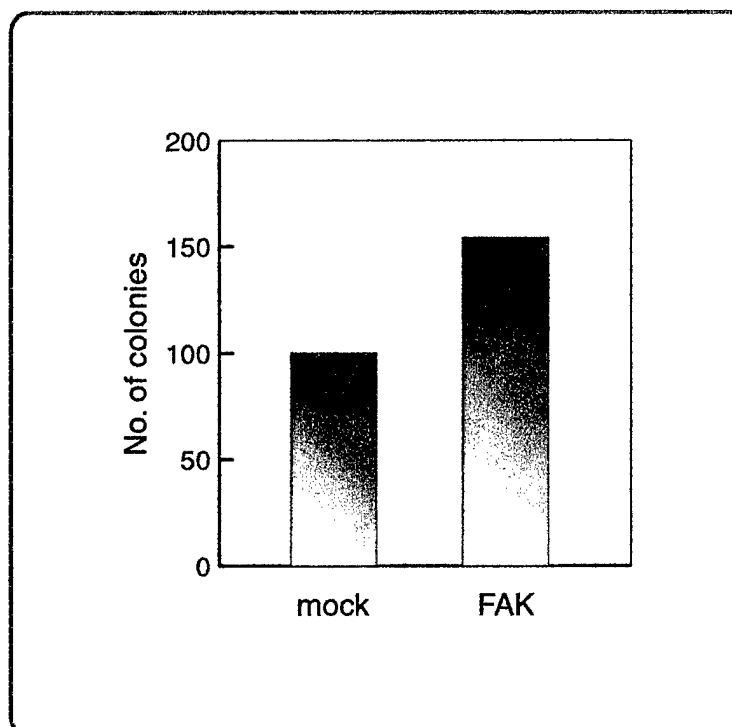
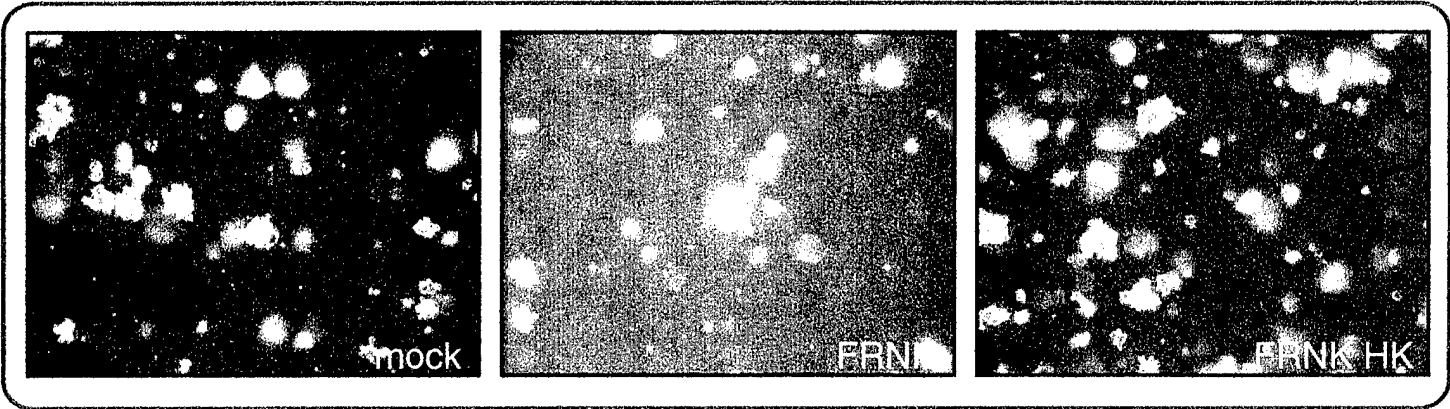

Figure 6

A.



B.

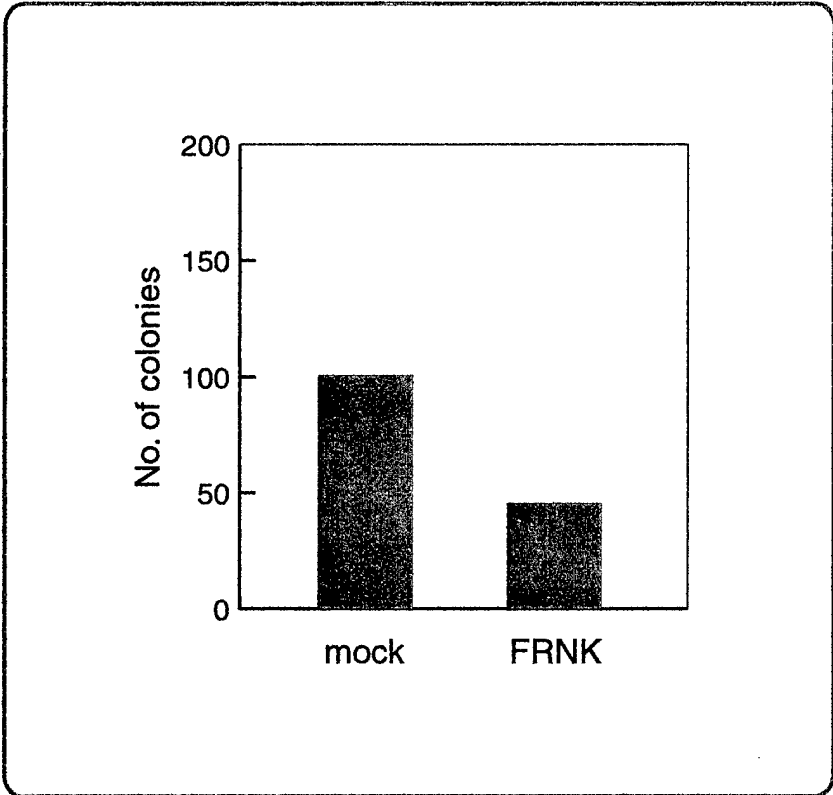
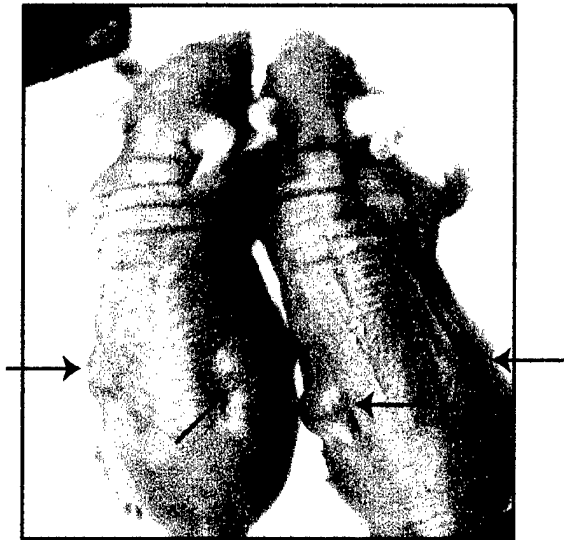
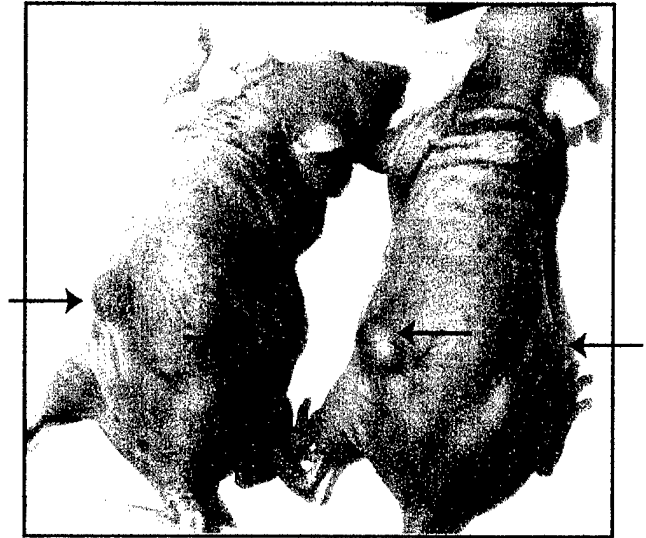

Figure 7



Mock



FRNK

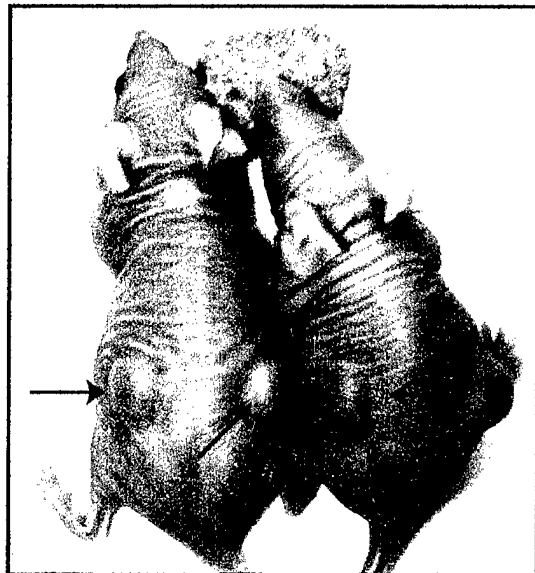

SuperFAK



APPENDIX B

Manuscript in Press: “Characterization of an activated mutant of Focal Adhesion Kinase: SuperFAK”

Characterization of an Activated Mutant of Focal Adhesion Kinase: SuperFAK

Veronica Gabarra-Niecko^{*}, Patricia J. Keely[†], Michael D. Schaller^{*†1}

^{*}Department of Cell and Developmental Biology and [†]Lineberger Comprehensive Cancer Center, University of North Carolina, Chapel Hill, NC 27599 and the [†]Department of Pharmacology, University of Wisconsin, Madison, WI 53706

Keywords: Integrin, motility, phosphotyrosine, paxillin, Src

Running Title: A hyperactive mutant of FAK

¹ Corresponding Author: Department of Cell and Developmental Biology
534 Taylor Hall CB 7090
University of North Carolina at Chapel Hill
Chapel Hill, NC 27599-7090
Phone: (919) 966-0391
Fax: (919) 966-1856
e-mail: crispy4@med.unc.edu

FAK is a non-receptor tyrosine kinase that plays an important role in normal cellular processes such as adhesion, spreading, migration, proliferation and survival. In addition, FAK is overexpressed in a variety of cancer cells and tumors, and may play a role in the development of human cancer. As a prelude to modeling the role of aberrant FAK signaling in the initiation of cancer, the goal of this study was to engineer point mutations in FAK that would enhance enzymatic activity. A number of substitutions, which were reported as activating mutations in other tyrosine kinases, were introduced into FAK. Glutamic acid substitutions for two lysine residues in the activation loop of FAK, based upon the K650E mutant of the FGFR3, were made to create SuperFAK. Two brain specific exons were engineered into avian FAK to create FAK6.7. SuperFAK and to a lesser degree FAK6.7, exhibited increased catalytic activity *in vitro* compared to wild type FAK. The expression of SuperFAK and FAK6.7 in fibroblasts led to hyperphosphorylation of FAK substrates. Although the catalytic activity of SuperFAK and FAK6.7 was largely independent of cell adhesion, tyrosine phosphorylation of downstream substrates was adhesion dependent. Further, since SuperFAK exhibited the same ability as wild type FAK to recruit Src family kinases, tyrosine phosphorylation of substrates was likely due to direct phosphorylation by FAK. In addition to enhanced biochemical signaling, SuperFAK also increased the motility of epithelial cells. SuperFAK and FAK6.7 may be valuable molecular tools to investigate the potential role of aberrant FAK signaling in human disease.

INTRODUCTION

The focal adhesion kinase (FAK)¹ is a non-receptor tyrosine kinase, first identified in Src-transformed fibroblasts [30]. FAK localizes to focal adhesions through its focal adhesion targeting (FAT) sequence located in the carboxyl terminus [14]. The clustering of integrins at focal adhesions upon engagement of their extracellular matrix (ECM) protein ligands results in tyrosine phosphorylation and activation of FAK [30]. In addition to adhesion, treatment of cells with a variety of soluble factors, including G-protein coupled receptor agonists and receptor protein tyrosine kinase ligands, can also induce FAK activation [30].

Upon activation, FAK autophosphorylates on tyrosine 397 (Y397) [3,34], creating a binding site for SH2 domain containing proteins. The p85 regulatory subunit of phosphatidylinositol 3-kinase (PI3K), phospholipase C- γ 1 (PLC- γ 1), growth factor receptor bound protein 7 (Grb7), and possibly Shc, bind to phosphorylated Y397 through SH2-mediated interactions [12,26,38,53]. In addition, the autophosphorylation site on FAK recruits Src-like kinases via their SH2 domains [34]. Furthermore, FAK contains a proline rich sequence upstream of Y397, which facilitates binding to the SH3 domain of Src and stabilization of the FAK/Src complex [8,45]. Once Src binds to FAK, it phosphorylates additional tyrosine residues on FAK, including tyrosines 576, 577, and 925 [3,36]. Phosphorylation of tyrosines 576 and 577, which reside in the activation loop of FAK, lead to maximal activation of FAK [3]. Phosphorylation of Y925 creates a binding site for the SH2 domain of Grb2, which may link FAK to MAPK signaling [36,37]. In addition to SH2 binding sites, FAK also contains proline rich regions that serve as docking sites for SH3-containing proteins including the crk-associated protein,

p130^{cas} [13,25]. FAK can thus recruit a variety of signaling proteins to form an intricate signaling complex.

FAK is implicated in controlling a variety of integrin mediated biological processes. FAK regulates turnover of focal adhesions, apparently by regulating the activity of Rho [9,18,27]. FAK also regulates cell motility. FAK null fibroblasts and cells expressing a dominant negative form of FAK show decreased migration [11].

Conversely, the overexpression of FAK in Chinese hamster ovary (CHO) cells increases cell motility [4]. The autophosphorylation site of FAK is required for the regulation of cell motility [4] and two effectors, PI3K and Src kinases, have been shown to function in the FAK-dependent regulation of cell motility [4,26]. Furthermore, p130^{cas} has been implicated as a downstream component of the FAK-mediated signaling pathway controlling motility [5]. In addition to migration, FAK also plays a role in mediating cell survival. Inhibition of FAK signaling causes cells to undergo apoptosis [16,51].

Furthermore, a constitutively activated, FAK-containing chimeric protein, CD2FAK, is able to rescue cells held in suspension from undergoing anoikis [10]. Recently FAK overexpression was shown to inhibit apoptosis induced by other stimuli [6,44]. Roles for PI3K, p130^{cas} and Grb2 in FAK-mediated cell survival have been proposed [1,44]. In addition to regulating cell survival, FAK may also function in the positive regulation of the cell cycle by controlling the levels of cyclin D and cyclin-dependent kinase inhibitor, p21 [54]. Although some of the mechanisms of action are not fully understood, FAK transduces important biological signals following integrin-dependent cell adhesion.

Constitutively activated FAK variants have been described previously [7,17]. However, activation has been achieved by targeting FAK constitutively to the cell

membrane. Since FAK is not membrane bound, these variants may have acquired novel properties and may not fully mimic FAK. Therefore, the creation of an activated mutant of FAK exhibiting proper cellular localization is of special interest. A number of reports in the literature describe activating point mutations in tyrosine kinases. These include a valine to isoleucine mutation in the ATP binding pocket of the EGF receptor [42], a methionine to threonine mutation in the carboxyl terminal lobe of the catalytic domain of RET, Met/HGF/SFR, Ron/RMSh, and Kit kinases [15, 23, 24, 29], and substitution of a glutamic acid for a lysine residue in the activation loop of the Fibroblast Growth Factor Receptor type 3 (FGFR3) [49]. In this study, we describe the construction and characterization of activated mutants of FAK. Point mutations shown to activate other tyrosine kinases were engineered into FAK. In addition, the regulatory tyrosine residues in the activation loop of FAK, Y576 and Y577, were mutated to glutamic acid to potentially mimic their phosphorylation. Finally, an avian version of FAK6.7, a neuronal FAK variant with two inserts flanking the autophosphorylation site of FAK that exhibits high autophosphorylation activity was also engineered [2]. Two of the mutants, SuperFAK (with glutamic acid for lysine substitutions in the activation loop) and FAK6.7, exhibited elevated catalytic activity compared to wild type FAK. Furthermore, expression of these mutants led to the hyperphosphorylation of FAK substrates, tensin and paxillin, as well as FAK itself. Strikingly, upon loss of adhesion, substrate phosphorylation disappeared in SuperFAK and FAK6.7 overexpressors, despite the fact that the kinase activity of the mutants remained high. The increased signaling capacity of SuperFAK and FAK6.7 occurred without affecting FAK-Src complex formation or Src activation implicating FAK activity itself in the augmentation of downstream signaling.

In addition to enhanced biochemical signaling, the activated mutant SuperFAK was also able to enhance biological signals since expression of SuperFAK increased cell motility in T47D breast epithelial cells. These activated FAK mutants may be powerful molecular tools for investigating the potential role of FAK signaling in the pathology of human disease, including cancer.

EXPERIMENTAL

Cloning and Mutagenesis

In order to make an avian version of FAK6.7, the codons for the 6 (393DEISGD₃₉₈) and 7 (412KSYGIDE₄₁₈) amino acid inserts were introduced into the avian FAK cDNA by site-directed mutagenesis using the Altered Sites Mutagenesis Kit (Promega, Madison, WI). Mutants were identified by PCR amplification and nucleotide sequencing. The Msc I-Sal I fragment of the mutated cDNA (extending from nucleotide 1178 in FAK to the multiple cloning sequence of the vector, downstream of the FAK stop codon) was excised from the mutagenesis vector, pALTER, and substituted for the corresponding fragment of wild type FAK in pBluescript-FAK [31]. Point mutations were engineered into the full length avian FAK cDNA in pBluescript-FAK [31] by oligonucleotide-directed PCR mutagenesis using the Stratagene Quick Change kit (Stratagene, La Jolla, CA). Some mutants were initially identified by restriction digestion. To verify the presence of the intended mutations and that no unintended mutations were introduced during the mutagenesis procedures, each construct was completely sequenced at the UNC-CH Automated DNA Sequencing Facility on a model 377 DNA Sequencer (Perkin-Elmer, Applied Biosystems Division) using the ABI PRISM™ Dye Terminator Cycle Sequencing Ready Reaction Kit with AmpliTaq DNA Polymerase, FS (Perkin-Elmer, Applied Biosystems Division). The full-length mutant FAK cDNAs were subcloned into the replication competent, avian retroviral vector, RCAS type A. RCAS A-FAK and RCAS B-c-Src constructs have already been described [14,32,33].

Cells and Viruses

Chicken embryo (CE) cells were harvested from 9-day-old embryos and grown as previously described [28]. T47D breast epithelial cells and the T47D/Tva derivatives were maintained in RPMI 1640 (Gibco/BRL, Rockville, MD) supplemented with 10% fetal bovine serum (Gibco/BRL, Rockville, MD), 0.2 U/ml insulin (Gibco/BRL, Rockville, MD), penicillin, streptomycin, genamycin and kanamycin (Sigma St. Louis, MO). CE cells were transfected with RCAS plasmid DNA using the LipofectAMINE PLUSTM reagent (Gibco/BRL, Rockville, MD) following the manufacturer's recommended protocol. Seven days after transfection, cells were lysed and FAK expression was analyzed. T47D cells were transfected with the avian retroviral receptor Tva800 cDNA (a generous gift from Dr. P. Bates) [52] using the Superfect reagent (Qiagen, Valencia, CA). Cells were selected in G418-containing growth medium and expanded as stably transfected cells. Expression of constructs was determined by fluorescent immunolabeling using a polyclonal antibody to the Tva receptor (a generous gift from Dr. P. Bates) and a secondary FITC conjugated anti-rabbit antibody (Jackson ImmunoResearch Laboratories Inc., West Grove, PA) followed by fluorescence analysis through flow cytometry.

Viral stocks were made from subconfluent cultures of CE cells 10 days after transfection. The culture medium was removed, 4 mls of fresh culture medium was added, and the cells were incubated overnight. The culture medium was collected, cells and debris were pelleted by centrifugation, and virus-containing supernatants were aliquoted and stored at -70° C. Upon passaging T47D cells, 1 ml of virus stock was added

to the T47D cultures. Ten to fourteen days after infection, cells were lysed and FAK expression was analyzed.

For adhesion experiments, cells were trypsinized and washed twice in phosphate-buffered saline (PBS) containing 0.5 mg/ml soybean trypsin inhibitor (Sigma, St. Louis, MO). Cells were resuspended in serum-free medium and kept in suspension for 45 min at 37°C. Suspended cells were then collected and lysed or plated at a concentration of 2.5×10^5 cells/ml on fibronectin coated dishes (50 µg/ml) for the indicated times prior to lysis [40].

Protein Analysis

Cells were lysed in modified radioimmunoprecipitation (RIPA) buffer containing protease and phosphatase inhibitors as previously described [41]. The protein concentration of the lysates was determined using the bicinchoninic acid assay (Pierce, Rockford, IL).

For immunoprecipitations, 0.3-1 mg of cell lysate was incubated with primary antibody on ice for 1 hr. The polyclonal FAK antibody BC4, monoclonal tensin antibody 5B9 (kind gifts from Dr. Tom Parsons), Fyn antiserum (a generous gift from Dr. André Veillette), the monoclonal Src antibody EC10 (a generous gift from Dr. Sally Parsons), paxillin and p130^{cas} antibodies (Transduction Labs, Lexington, KY) were used for immunoprecipitations. Immune complexes were precipitated with protein A sepharose beads (Sigma, St. Louis, MO), or rabbit anti-mouse IgG (Jackson Immunoresearch Laboratories Inc., West Grove, PA) pre-bound to protein A sepharose beads (Sigma, St. Louis, MO) at 4° C for 1 hr. The immune complexes were then washed twice with modified RIPA buffer, and twice with Tris-buffered saline (TBS) (10 mM Tris, 150 mM

NaCl, pH 7.0). Immune complexes were denatured and dissociated from beads by boiling in Laemmli sample buffer [22]. The samples were then resolved by SDS-PAGE on an 8% gel, and analyzed by Western blotting. Nitrocellulose membranes were blocked with TBS-T (10 mM Tris, 150 mM NaCl, pH 7.0, containing 0.1% Tween 20) containing 5% w/v powdered milk or with TBS-T alone when using the RC20 phosphotyrosine antibody or with TBS-T containing 2% fish gelatin (Sigma, St. Louis, MO) at 4° C overnight when using the FAK PY397 phosphospecific antibody. Membranes were incubated with primary antibody in blocking solution for 1 hr at room temperature. The antibodies described above were used for Western blotting. For detection of phosphotyrosine horseradish peroxidase conjugated RC20 (Transduction Labs, Lexington, KY) or polyclonal FAK PY397, Src PY416, and Src PY527 phosphospecific antibodies (BioSource International, Camarillo, CA) were used. Membranes were incubated overnight at 4° C when using the FAK PY397 phosphospecific antibody. Primary antibodies were detected using horseradish peroxidase conjugated to protein A or anti-mouse IgG and Enhanced Chemiluminescence (Amersham Pharmacia Biotech, Piscataway, NJ).

***In vitro* Kinase Assays**

For *in vitro* kinase reactions, FAK or Src immune complexes were washed twice in modified RIPA buffer, twice with TBS and once with kinase reaction buffer (20 mM PIPES pH 7.2, 3 mM MnCl₂ and MgCl₂) or enolase kinase buffer (20mM PIPES pH 7.2, 10 mM MgCl₂, 1 mM dithiothreitol). For enolase kinase assays, 5 µg of acid denatured enolase (Sigma, St. Louis, MO) was added to each reaction. For PP2 treatments, either 0.5 µM PP2 (Calbiochem, San Diego, CA) or vehicle, dimethyl sulfoxide (DMSO)

(Fischer Scientific, Pittsburgh, PA) alone were added to the kinase buffer. The immune complexes were then incubated in kinase buffer and 10 μCi $\gamma^{32}\text{P}$ -ATP (DupontNEN, Wilmington, DE) at room temperature for the times indicated. The kinase reactions were stopped by boiling in Laemmli sample buffer [22]. The reactions were subjected to SDS-PAGE. The gels were fixed in 7% acetic acid and 20% methanol and dried. ^{32}P incorporation was visualized by autoradiography and phosphorimager analysis using the Storm860 (Molecular Dynamics, Sunnyvale, CA).

***In vitro* Binding Assay**

The glutathione S-transferase (GST) fusion proteins were expressed in *E. coli* and purified as described [43]. Briefly, expression was induced by the addition of 0.1 mM isopropyl-1-thio- β -D-galactopyranoside and incubation at 37° C for 2 hrs. The bacteria were harvested and lysed by sonication in 1% Triton X-100 in PBS containing protease inhibitors (1 mM PMSF, 0.5 mM EDTA pH 8.0, 10 $\mu\text{g}/\text{ml}$ leupeptin, 10 $\mu\text{g}/\text{ml}$ aprotinin). Clarified supernatants were incubated with glutathione-agarose beads (Sigma, St. Louis, MO) for 1 h at 4° C, washed, and finally resuspended in an equal volume of PBS. The fusion proteins were analyzed by SDS-PAGE and Coomassie Blue staining.

Approximately 0.5-1 mg of protein lysate was pre-cleared by incubation with GST immobilized on glutathione-Sepharose beads for 1 hr at 4° C. For GST-Grb2SH2 pulldowns, cells were treated overnight with 50 μM sodium orthovanadate before lysing. The cleared lysates were then incubated with 2 μg of GST alone or GST-SH2 domain fusion proteins immobilized on glutathione-Sepharose beads for 2 hr at 4° C. The beads were washed twice with modified RIPA buffer and twice with TBS. The bound proteins

were denatured and eluted from the beads by boiling in Laemmli sample buffer [22] and analyzed by Western blotting.

Motility

Motility assays were performed as described previously [20]. The underside of 12 mm transwell chambers with a 12 μ m pore polycarbonate membrane (Costar, Cambridge, MA) were coated with 0.6 ml of 40 μ g/ml rat tail collagen I (Collaborative Biomedical Products, Bedford, MA) for 6 hrs at 37 $^{\circ}$ C. The lower chamber was washed twice and filled with serum free RPMI1640 medium. T47D cells were trypsinized, counted and resuspended in RPMI1640 medium supplemented with 5 mg/ml BSA (Sigma, St. Louis, MO) to a total concentration of 3×10^6 cells/ml. 1.5×10^6 cells were added to the top chamber of the transwell. The T47D cells were allowed to migrate for 20-22 hrs at 37 $^{\circ}$ C. Cells remaining on the top of the polycarbonate membrane were removed. Cells that had migrated to the underside of the membrane were stained with DiffQuick (Baxter, Miami, FL). The cells were counted across two diameters, a total of 10 fields, each on duplicate membranes. A mixed model test as well as paired and unpaired Student t-tests were performed using the TMSAS software (Cary, NC) to identify statistically significant differences in average fold change of motility.

RESULTS

A number of mutations known to activate tyrosine kinases were engineered into avian FAK (Fig 1). The Y576E/Y577E, V436I and M589T mutations had no effect on the kinase activity of FAK or signaling downstream of FAK (data not shown) and thus were not further characterized. The K578E/K581E mutant, referred to as SuperFAK, and the alternatively-spliced neuronal form, FAK6.7, exhibited elevated catalytic activity and were more extensively characterized.

SuperFAK has increased catalytic activity compared to wild type FAK

SuperFAK and FAK6.7 were subcloned into the RCAS A retroviral vector and expressed in CE cells. Western blotting of CE cell lysates with a polyclonal FAK antibody revealed that wild type FAK, SuperFAK and FAK6.7 were expressed at equal levels (Fig 2a). The altered electrophoretic mobility of FAK6.7 was due to the two insertions (Fig 2a; lane 4). Immunofluorescence studies demonstrated that, like wild type FAK, both SuperFAK and FAK6.7 localized to focal adhesions (data not shown).

To determine the effect of the introduced mutations and insertions on catalytic activity, FAK, SuperFAK and FAK6.7 were subjected to *in vitro* kinase assays. The proteins were immunoprecipitated from CE lysates and then incubated in kinase reaction buffer for the indicated times. The kinase reactions were stopped by the addition of Laemmli sample buffer and analyzed by SDS-PAGE and autoradiography [22]. Autophosphorylation of endogenous FAK was not detected at this exposure (Fig 2b; top panel; lane 1) due to the small amount of endogenous FAK that is recovered relative to the exogenously expressed proteins (Fig 2b; bottom panel). However, autophosphorylation of exogenous wild type FAK was readily detected (Fig 2b; top

panel; lanes 2 and 3). A significant increase in autophosphorylation activity was observed in SuperFAK immune complexes compared to wild type FAK (Fig 2b; top panel; lanes 4 and 5). FAK6.7 also exhibited increased autophosphorylation activity relative to wild type FAK, but the increase was less dramatic than that of SuperFAK (Fig. 2a; top panel; lanes 6 and 7). Phosphorimager analysis revealed that FAK6.7 exhibited 2-5 fold higher activity than wild type FAK and that the activity of SuperFAK was 4-12 times greater than wild type FAK. The immune complexes were also Western blotted with a polyclonal antibody to FAK to demonstrate that equivalent levels of each FAK protein were present in the immunoprecipitates (Fig 2; bottom panel). It can be concluded that the mutations introduced into SuperFAK and FAK6.7 lead to an increase in *in vitro* kinase activity compared to wild type FAK.

Increased phosphorylation of downstream cellular proteins

Since SuperFAK and FAK6.7 had increased catalytic activity *in vitro*, the ability of these mutants to increase FAK signaling *in vivo* was investigated. Phosphotyrosine levels in CE cells expressing wild type FAK or the FAK mutants were used as a measure of FAK signaling. Whole cell lysates from CE cells were analyzed by Western blotting with a phosphotyrosine antibody (Fig 3a). As previously described, overexpression of wild type FAK leads to only a slight increase in cellular phosphotyrosine, and the major tyrosine phosphorylated band corresponds to FAK itself [35] (Fig 3a; top panel; lane 2). However, a striking increase in cellular phosphotyrosine was observed in SuperFAK overexpressors, and to a lesser degree in FAK6.7 overexpressors (Fig 3a; top panel; lanes 3 and 4). The major phosphotyrosine containing proteins were approximately 200, 125 and 68-75 KDa in size (Fig 3a; arrows). Based upon these molecular weights, and

previous studies of FAK substrate phosphorylation [35], it seemed likely that tensin, FAK and paxillin were the major targets for enhanced phosphorylation in these cells.

In order to verify the identity of the proteins that were hyperphosphorylated, tensin, FAK, and paxillin were immunoprecipitated from lysates of CE cells overexpressing wild type FAK or the mutant FAK proteins. The immune complexes were analyzed by Western blotting for phosphotyrosine (Fig 3b-d; top panels). FAK immunoprecipitated from CE cells transfected with wild type FAK had a strong phosphotyrosine signal compared to mock transfected cells due to the expression of the exogenous wild type FAK protein (Fig 3b; top panel; lanes 2). A modest increase in the phosphorylation of the immunoprecipitated FAK was observed when SuperFAK, and to a lesser degree, when FAK6.7 was expressed (Fig 3b; top panel; lanes 3 and 4). The phosphorylation of tensin and paxillin was slightly elevated upon expression of wild type FAK compared to mock cells, as was previously described [35] (Figure 3c and d; top panels; lanes 2). The phosphotyrosine content of both tensin and paxillin was significantly increased in SuperFAK expressing cells compared to wild type FAK expressing cells (Fig 3c and d; top panels; lanes 3). Although, not as dramatic, FAK6.7 also caused an elevation in the phosphotyrosine content of both tensin and paxillin compared to wild type FAK (Fig 3c and d; top panels; lanes 4). The phosphotyrosine content of an additional FAK substrate, p130^{cas} was similarly analyzed. In contrast to the observed phosphorylation differences on tensin and paxillin, no significant change in the phosphotyrosine content of p130^{cas} was observed when either wild type FAK, SuperFAK or FAK6.7 were expressed (Fig 3e; top panel). Control Western blots verified that equal amounts of protein were being immunoprecipitated in each case (Fig 3b-e; bottom

panels). These observations indicate that the elevated catalytic activity exhibited by SuperFAK and FAK6.7 is sufficient to amplify signaling events immediately downstream of FAK. Interestingly, phosphorylation of some FAK associated, tyrosine phosphorylated proteins, i.e. paxillin, was increased whereas phosphorylation of others was not, i.e. p130^{cas}. Furthermore, the level of FAK substrate phosphorylation *in vivo* correlated with the catalytic activity of the kinases *in vitro*.

Cell Adhesion dependent regulation of SuperFAK and FAK6.7 Signaling.

Cell adhesion is a major stimulus regulating FAK-mediated signal transduction. Upon cell detachment from the ECM, FAK becomes dephosphorylated, its catalytic activity declines and downstream signals are turned off [30]. To determine if SuperFAK and FAK6.7 were constitutively active and able to send signals independent of cell adhesion, the cellular phosphotyrosine content was monitored in CE cells expressing wild type FAK or the FAK mutants. The cells were either kept in culture or held in suspension for 45 min prior to lysis. Lysates were analyzed by Western blotting with a phosphotyrosine antibody (Fig 4a; top panel). As described above (Fig 3a), expression of SuperFAK, and to a lesser degree FAK6.7, increased cellular phosphotyrosine to a higher level than wild type FAK in cultured cells (Fig 4a; top panel; lanes 3, 5, 7). When cells were detached, the cellular phosphotyrosine content was dramatically reduced in every cell type (Fig 4a; top panel; lanes 2, 4, 6, 8). The level of phosphotyrosine in suspended SuperFAK and FAK6.7 cells was similar to the level of phosphotyrosine in suspended mock cells (Fig 4a; top panel; lanes 2, 6, 8). Whole cell lysates were also Western blotted for FAK, to ensure equal expression of FAK protein (Fig 4a; bottom panel). These

observations indicate that the downstream phosphorylation signals mediated by SuperFAK and FAK6.7 are adhesion dependent.

In vitro kinase assays were performed to investigate whether the decreased tyrosine phosphorylation observed upon loss of adhesion in SuperFAK and FAK6.7 overexpressors was due to a reduction in catalytic activity. FAK or the activated FAK mutants were immunoprecipitated from cultured CE cells or cells held in suspension. The immune complexes were incubated in kinase reaction buffer for 5 minutes at room temperature. The kinase reactions were stopped with the addition of Laemmli sample buffer and the samples analyzed by SDS-PAGE and autoradiography. As expected from previous studies [30], the activity of wild type FAK in suspended cells was decreased compared to the activity of FAK in adherent cells (Fig 4b; top panel; lanes 3 and 4). As shown above (Fig 2b), an elevation of the autophosphorylation activity of SuperFAK, and to a lesser degree FAK6.7, was observed in adherent cells (Fig 4b; top panel; lanes 3, 5, 7). Although the kinase activity of SuperFAK and FAK6.7 decreased in the absence of an adhesion signal (Fig 4b; top panel; lanes 5 and 6, 7 and 8), SuperFAK and FAK6.7 still exhibited significantly higher catalytic activity compared to wild type FAK (Fig 4b; top panels; lanes 4, 6, 8). In fact, the autophosphorylation activity of SuperFAK from suspended cells was higher than the activity of wild type FAK from adherent cells (Fig 4b; top panel; lanes 3, 6). As a control for equal FAK loading, the immunoprecipitates were Western blotted for FAK (Fig 4b; bottom panel). These results indicate that SuperFAK, and to a lesser degree FAK6.7, exhibit elevated catalytic activity in the presence or in the absence of adhesion. The loss of downstream phosphotyrosine signals in suspended cells can only be partially due to the decrease in catalytic activity of the

FAK mutants, suggesting an additional mechanism(s) is involved in regulating tyrosine phosphorylation of focal adhesion-associated substrates.

In order to test whether the activated FAK mutants generated enhanced responses to physiological signals, tyrosine phosphorylation of paxillin was examined following cell adhesion to fibronectin. Paxillin was immunoprecipitated from lysates of cultured cells, cells kept in suspension for 45 minutes, or cells replated on fibronectin-coated dishes. The paxillin immune complexes were then Western blotted with a phosphotyrosine antibody. As before (Fig 3d), SuperFAK, and to a lesser degree FAK6.7 increased the level of tyrosine phosphorylation on paxillin compared to wild type FAK in cultured cells (Fig 5; top panel; lanes 4, 7, 10). Upon loss of adhesion, paxillin phosphorylation was lost regardless of which FAK construct was expressed (Fig 5; top panel; compare Cul vs Su). This result correlates with the previous observation of phosphotyrosine levels in lysates of suspended cells (Fig 4a). Fibronectin-mediated adhesion induced tyrosine phosphorylation of paxillin in all the cells (Fig 5; top panel; lanes 3, 6, 9 and 12). The level of paxillin phosphorylation was significantly higher in cells expressing SuperFAK or FAK6.7 compared to cells expressing wild type FAK (Fig 5; top panel; lanes 6, 9, 12). The immune complexes were Western blotted for paxillin in order to verify that equal amounts of protein were analyzed (Fig 5; bottom panel). These observations demonstrate that the activated FAK mutants elevate FAK-mediated signals in response to a physiologically relevant stimulus.

Phosphorylation Status of Tyrosine Residues in SuperFAK and FAK6.7

One possible mechanism through which the activated mutants might elevate downstream signaling is by recruiting Src family kinases into complex and/or enhancing

signaling by Src family kinases. In order to investigate the role of Src in SuperFAK and FAK6.7 enhanced signaling several lines of investigation were pursued. Lysates of CE cells expressing wild type FAK, SuperFAK or FAK6.7 were Western blotted with a phosphospecific antibody against Y397 (PY397), which is the Src SH2 domain binding site on FAK (Fig 6a; top panel). To control for specificity, a FAK mutant with a phenylalanine for tyrosine substitution at this site was used as a negative control. PY397 recognized wild type FAK but not the Y397F mutant (Fig 6a; lane 2 and 3). Similar phosphorylation levels on Y397 were observed between wild type FAK, SuperFAK and FAK6.7 (Fig 6a; top panel; lanes 2, 4, 5). Lysates were Western blotted for FAK to ensure equivalent amounts of FAK protein were analyzed (Fig 6a; bottom panel). These observations indicate that neither SuperFAK nor FAK6.7 exhibit increased phosphorylation at Y397 *in vivo*.

To analyze the ability of the activated FAK mutants to associate with the Src SH2 domain *in vitro*, a GST fusion protein containing the SH2 domain of Src was used. GST fusion proteins were incubated with cell lysates and the bound proteins were Western blotted to determine the amount of associated FAK. To ensure comparable levels of FAK protein expression, whole cell lysates were Western blotted for FAK (Fig 6b; bottom panel). GST alone was used to control for non-specific FAK binding (Fig 6b; top panel; lane 1). Similar amounts of exogenous wild type FAK and the activated FAK mutants bound to GST-SrcSH2 (Fig 6b; top panel; lane 3-5). These observations demonstrate that there were no changes in the ability of SuperFAK or FAK6.7 to associate with Src *in vitro* compared to wild type FAK and are in agreement with the results of the PY397 Western blot (Fig 6a).

Co-immunoprecipitations were also performed to analyze the association of Fyn with FAK *in vivo*. Fyn was immunoprecipitated from CE cell lysates that overexpressed wild type FAK, SuperFAK or FAK6.7. The immune complexes were Western blotted for FAK (Fig 6c; top panel). The same amount of FAK, SuperFAK and FAK6.7 were co-immunoprecipitated with Fyn (Fig 6c; top panel; lanes 3-5). As a control, secondary antibody was used alone in an immunoprecipitation to demonstrate that the co-immunoprecipitation of FAK was specific (Fig 6c; top panel; lane 1). The blots were also stripped and reprobed for Fyn to ensure that equal amounts of Fyn were immunoprecipitated (Fig 6c; bottom panel). These observations indicate that SuperFAK, FAK6.7 and wild type FAK associate with equivalent amounts of Fyn *in vivo*.

Two approaches were taken to determine if Src family kinases, in complex with FAK, were responsible for the enhanced catalytic activity of SuperFAK *in vitro*. First, kinase assays were performed in the presence of the Src inhibitor PP2. FAK was immunoprecipitated from CE lysates expressing vector alone, FAK or SuperFAK. The immune complexes were then incubated in kinase reaction buffer in the presence or absence of PP2 and terminated by the addition of Laemmli sample buffer. The samples were subject to SDS-PAGE and autoradiography. As described above (Fig 2b), SuperFAK had increased autophosphorylation levels compared to wild type FAK (Fig 7a, lanes 3, 5). Most importantly, the presence of PP2 had no effect on the autophosphorylation activity of wild type FAK or SuperFAK (Fig 7; lanes 3, 4 and 5, 6). In the second approach, an enolase substrate kinase assay was used to measure Src activity in FAK complexes. Immune complexes were incubated in reaction buffer with acid denatured enolase and the samples analyzed by SDS-PAGE and autoradiography. As

a control, Src^{527F} immune complexes were used and shown to prominently phosphorylate enolase (Fig 7b; lane 1, 10). In the presence of 0.5 μM PP2, Src^{527F} autophosphorylation and enolase phosphorylation were significantly inhibited (data not shown and Fig 7; lanes 1,2 and 10,11). FAK immune complexes weakly phosphorylated enolase and SuperFAK immune complexes induced enhanced enolase phosphorylation (Fig 7b; lanes 6 and 8). However, the presence of PP2 had no effect on the phosphorylation of enolase by FAK or SuperFAK (Fig 7b; lanes 6,7 and 8,9). This observation suggests that the weak phosphorylation of enolase by FAK and SuperFAK immune complexes was due to FAK activity and not due to co-immunoprecipitating Src family kinase activity. These results demonstrate that the increased activity of SuperFAK *in vitro* is not due to enhanced activity of co-immunoprecipitating Src kinases.

The results of the phosphospecific antibody Western blots, *in vitro* binding assays, Fyn co-immunoprecipitations and *in vitro* kinase assays indicate that FAK, SuperFAK and FAK6.7 are equally phosphorylated on Y397 and bind comparable amounts of Src kinases. However, there remains the possibility that these FAK variants might elevate Src activity *in vivo*. In order to investigate this possibility, the activation state of Src was examined using phosphospecific antibodies. Cell lysates were western blotted with phosphospecific antibodies to Y416 (PY416), which is in the activation loop of Src, or Y527 (PY527), which is a negative regulatory site of phosphorylation. As controls for specificity CE cells expressing c-Src or Src^{527F} were analyzed. Under steady state conditions, c-Src is largely inactive, and phosphorylation of Y416 is low whereas phosphorylation of Y527 is high. Src^{527F} cannot be phosphorylated on Y527, rendering it highly active and resulting in high phosphorylation of Y416. The phosphospecific PY416

antibody prominently recognized Src^{527F} and weakly recognized c-Src suggesting that the antibody was specific to Y416 (Fig 8a; top panel). The specificity of PY527 was also verified since this antibody recognized c-Src, but not Y527F Src (Fig 8a; middle panel). Upon co-expression with wild type FAK, an increase in Y416 phosphorylation was observed on c-Src (Fig 8b; top panel; lanes 1, 2), indicating that co-expression with FAK can activate Src. The level of Y416 phosphorylation when SuperFAK or FAK6.7 was co-expressed with c-Src was the same as in cells co-expressing wild type FAK and c-Src (Fig 8b; top panel; lanes 2-4). The level of phosphorylation of Y527 on c-Src remained unchanged regardless of co-expression of FAK proteins (Fig 8b; second panel). To monitor the amounts of protein being analyzed, Src and FAK Western blots were performed (Fig 8a; bottom panel and Fig 8b; third and bottom panels). The observations indicate that wild type FAK, SuperFAK and FAK6.7 have similar effects on the phosphorylation of Src. Therefore the mechanism by which SuperFAK and FAK6.7 send amplified signals *in vivo* is not via enhanced activation of Src kinases.

The phosphorylation of Y925 in the carboxyl-terminus of FAK creates a binding site for the SH2 domain of Grb2 [36,37]. To explore phosphorylation of Y925 a phosphospecific antibody was initially used. However, under the blotting conditions used, this antibody recognized a FAK mutant with a phenylalanine substitution for Y925 (data not shown), precluding its use in this analysis. As an alternative approach, Y925 phosphorylation in SuperFAK and FAK6.7 was investigated by examining the ability of the FAK mutants to associate with the Grb2SH2 domain *in vitro*. A GST fusion protein containing the Grb2SH2 domain was incubated with vanadate treated lysates of CE cells expressing FAK, or the activated FAK variants, and bound proteins analyzed by Western

blotting for FAK. To ensure comparable levels of FAK protein expression, whole cell lysates were Western blotted for FAK (Fig 9; bottom panel). FAK bound to the GST-GrbSH2 domain but failed to associate with GST alone (Fig 9; top panel; lanes 1,3). Higher levels of SuperFAK were found associated with the Grb2 SH2 domain compared to wild type FAK (Fig 9; top panel; lanes 3, 4). In contrast, similar amounts of FAK6.7 and wild type FAK associated with the Grb2 SH2 domain (Fig 9; top panel; lanes 3, 5). These results suggest that SuperFAK has elevated phosphorylation at Y925.

Increased Motility of T47D cells expressing SuperFAK

Since SuperFAK and FAK6.7 increased FAK signaling biochemically, the ability of these mutants to impinge upon FAK-mediated biological processes were tested. In order to investigate the effects of the activated FAK proteins on cell motility, T47D cells, a breast cancer epithelial cell line, were utilized. The T47D cells were engineered to stably express the receptor for the avian subgroup A retrovirus, Tva800 [52]. Whereas, the parental T47D cells are resistant to infection with avian retroviruses since the cells lack the viral receptor, the derived cell line, T47D/Tva, is susceptible to infection with avian A type retroviruses. The FAK constructs, cloned into RCAS type A, were transfected into CE cells. Virus produced in CE cells was collected and used to infect the T47D/Tva cells to generate populations of cells expressing each of the FAK proteins of interest. Western blots were performed to examine expression of FAK proteins following infection of the T47D/Tva cells. These results demonstrated that FAK, SuperFAK and FAK6.7 were expressed to high levels in the T47D/Tva cells (Fig 10a).

Using a transwell motility assay as previously described [20], the haptotactic motility of the cells was analyzed. Populations of infected T47D/Tva cells were allowed

to migrate for 20-22 hours through a porous transwell membrane coated on the underside with collagen I (40 µg/ml). The non-motile cells were removed from the top of the membrane, the cells that migrated to the underside of the membrane were stained and counted. The average fold change in motility was plotted (Fig 10b). The motility of T47D cells was significantly increased by FAK overexpression, which is consistent with previous findings demonstrating a role for FAK in regulating motility in other cell types [4,11,18]. Expression of SuperFAK further increased the motility of T47D cells compared to cells expressing FAK, whereas FAK6.7 was less efficient than wild type FAK in enhancing haptotaxis. These observations demonstrate the ability of SuperFAK to amplify a FAK-mediated biological response.

DISCUSSION

In this study, we describe the construction of two activated mutants of FAK: SuperFAK and FAK6.7. SuperFAK, and to a lesser degree, FAK6.7, showed increased catalytic activity *in vitro* compared to wild type FAK. The catalytic activity of both mutants was partially regulated by adhesion since both exhibited reduced catalytic activity from cells in suspension. Nevertheless, the enzymatic activity of SuperFAK from suspended cells greatly exceeded the activity of wild type FAK. The elevated activity of SuperFAK and FAK6.7 translated into increased downstream biochemical signals *in vivo*, as demonstrated by the phosphorylation of FAK substrates i.e. paxillin and tensin. Despite the high level of catalytic activity of SuperFAK in suspended cells, phosphorylation of downstream substrates by SuperFAK, as well as FAK6.7, was dependent on adhesion. The expression of the activated FAK mutants in CE cells had no effect on cell morphology and their subcellular localization was identical to that of wild type FAK (data not shown). Furthermore, the elevation of the FAK signal upon SuperFAK expression leads to increased motility of breast cancer cells. Thus, the activated mutant of FAK, SuperFAK, may be a powerful tool that can be used to study the consequences of increased and/or aberrant FAK signaling in a variety of physiological contexts.

In many protein kinases, phosphorylation of residues in the activation loop, analogous to Y576 and Y577 in FAK, is a mechanism of enzyme activation [19]. The negative charge introduced by the phosphate groups stabilizes the active conformation, in which the ATP and the substrate binding sites of the kinase domain are accessible [19]. In the case of the Y576E/Y577E FAK mutant, no change in catalytic activity or downstream

tyrosine phosphorylation signals was observed. It was expected that the introduction of the charged residues might mimic phosphorylation of the tyrosine residues, which normally enhances the catalytic activity of FAK [3]. However, it appears that the tyrosine to glutamic acid substitutions in Y576E/Y577E were not sufficient to cause the conformational change necessary for the activation of FAK. Interestingly, although substitutions of acidic residues for activation loop phosphorylation sites can activate some protein kinases e.g. MEK [19], there are no reports of mutational activation of tyrosine kinases using this strategy. In the case of SuperFAK, the double substitution of the activation loop lysines (K₅₇₈K₅₈₁) with glutamic acids did lead to activation of the kinase, whereby catalytic activity was elevated and downstream biochemical and cellular events were augmented. Thus, the substitution of acidic residues for basic residues in the activation loop results in catalytic activation as originally reported for FGFR3 [49]. The negatively charged glutamic acid residues may alter the conformation mimicking the conformational change that occurs when the regulatory tyrosines in the activation loop of FAK are phosphorylated. Alternatively, the activation of SuperFAK could be explained by an increase in the level of phosphorylation of the regulatory tyrosines in the kinase domain of FAK, Y576 and Y577. The double lysine to glutamic acid substitution may alter the recognition of FAK by either a tyrosine kinase, likely Src, or a tyrosine phosphatase resulting in elevated phosphorylation of Y576 and Y577 leading to enhanced activity.

FAK6.7 is an avian version of an alternatively spliced variant of FAK found in rat brain [2]. As previously reported, FAK6.7 has elevated autophosphorylation activity *in vitro* [2,47]. In addition, we have shown that this mutant can also elevate tyrosine

phosphorylation of substrates *in vivo*. The mechanism of activation of the mutant is not clear. It has been speculated that alterations around the autophosphorylation site might alter the level of phosphorylation at that site. It has been reported that FAK6.7 expressed in COS-7 cells does exhibit elevated phosphorylation at Y397 [47], however our analysis in fibroblasts does not show an elevation of phosphorylation at Y397 *in vivo*. Increased tyrosine phosphorylation of FAK at Y397 could result in increased recruitment of Src, but our results suggest that FAK6.7 does not exhibit increased Src binding *in vivo*. The discrepancy between published results and the present studies may be due to the different cell types and expression systems used or the use of different Y397 phosphospecific antibodies. In light of our observations, the mechanism of activation of FAK6.7 still remains to be solved.

Src plays an important role in biochemical signaling via FAK. Src can bind autophosphorylated FAK and phosphorylate activation loop residues to further promote the activity of FAK [3]. In addition, recruitment of Src into a complex with FAK may direct phosphorylation of paxillin and tensin *in vivo* by Src [35]. These observations raise the question of the role Src plays in signaling by SuperFAK and FAK6.7. Experiments using phosphospecific antibodies and GST fusion proteins indicate that there was no significant change in the level of phosphorylation of Y397 of the activated FAK mutants compared to wild type FAK. Further co-immunoprecipitation experiments reveal no difference in the association of Fyn with wild type FAK or the activated mutants. Similarly, experiments using a Src inhibitor in FAK kinase assays, also suggest that the increase in catalytic activity of SuperFAK is not due to increased association with Src kinases. These observations suggest that enhanced signaling by SuperFAK and FAK6.7

is not due to increased recruitment of Src kinases. A FAK-dependent mechanism of Src activation has been proposed [38,45]. However, experiments using Src phosphospecific antibodies demonstrate that SuperFAK and FAK6.7 activate Src *in vivo* to the same extent as wild type FAK. Thus, the enhanced effects of SuperFAK and FAK6.7 on downstream signaling might be independent of Src. Furthermore, from these studies it seems likely that paxillin and tensin are serving as direct substrates for SuperFAK and FAK6.7. In contrast, expression of SuperFAK or FAK6.7 did not result in elevated tyrosine phosphorylation of p130^{cas}. This observation is consistent with the hypothesis that Src is the major kinase responsible for tyrosine phosphorylation of p130^{cas} [46,48].

One interesting observation was the apparent increase in phosphorylation of Y925 in SuperFAK relative to wild type FAK and FAK6.7. Src has been shown to be the kinase responsible for phosphorylation of Y925 [37]. However, since there is no difference in the association of FAK and SuperFAK with Src family kinases the mechanism leading to phosphorylation of this site is unclear. Since phosphorylation of Y925 creates a Grb2 binding site linking FAK with the MAPK cascade [39] and SuperFAK exhibits elevated levels of phosphorylation at Y925 it was anticipated that SuperFAK might induce enhanced activation of ERK. However, no significant effect of SuperFAK upon adhesion-mediated or serum-mediated ERK activation was observed in CE cells (data not shown).

In our studies, the catalytic activity of SuperFAK and FAK6.7 was reduced when cells were held in suspension. However, in the absence of an adhesion signal, SuperFAK and FAK6.7 still displayed much higher kinase activity *in vitro* compared to wild type FAK. Thus, the kinase activity of SuperFAK and FAK6.7 is only partially regulated by

adhesion. These observations suggest that the mutants may not be constitutively active since they still require a cell adhesion stimulus for maximal activation. Nevertheless, these mutants exhibit higher enzymatic activity compared to wild type FAK. Although the catalytic activity of SuperFAK and FAK6.7 remained high in the absence of an adhesion signal, tyrosine phosphorylation of downstream effectors did not occur in cells in suspension. These observations indicate that the high catalytic activity of SuperFAK and FAK6.7 is insufficient to induce substrate phosphorylation in suspended cells. There are a number of possible explanations for this observation. The absence of FAK substrate phosphorylation could be attributed to the action of cellular phosphatases, which are more active, or have increased access to substrates when cells are in suspension. Alternatively, the proximity of the activated FAK mutants to its substrates represents another potential method of regulation. The assembly of proteins into focal adhesions may be required not only for the efficient activation of FAK, but also for the clustering of FAK with its substrates to promote their phosphorylation and the transmission of FAK downstream signals.

Several FAK binding partners have been implicated in mediating FAK-dependent cell motility, including Src family kinases and PI3K [4,26]. Src kinases are likely to phosphorylate downstream substrates to regulate motility and one important substrate implicated in cell motility is p130^{cas} [5,21]. A FAK mutant that cannot bind p130^{cas} or induce its tyrosine phosphorylation is defective for induction of motility, implicating p130^{cas} in the regulation of motility by FAK [5]. It may therefore be noteworthy that the FAK and SuperFAK do not induce p130^{cas} tyrosine phosphorylation, yet do promote cell

motility. FAK may utilize different signaling pathways to control cell motility in different cell types. Further experimentation is required to test this hypothesis.

The characterization of SuperFAK and FAK6.7 has demonstrated the ability of these constructs to increase FAK-mediated signals. Other membrane-bound constitutively activated FAK constructs, CD2FAK and myrFAK, have been described [7,17]. The best characterized of these FAK variants, CD2FAK, exhibits biochemical properties different than SuperFAK. First, its expression does not promote dramatic increases of tyrosine phosphorylation of substrates in adherent cells [10,48]. Second, in suspended cells expressing CD2FAK the tyrosine phosphorylation of paxillin and p130^{cas} are sustained [10,48]. Presumably, constitutive CD2FAK and MyrFAK signaling can be explained by their constitutive association with the membrane, and membrane-bound proteins, such as Src. This contrasts with the hyperactive signaling generated by SuperFAK and FAK6.7 in response to normal physiological stimuli. In this regard, SuperFAK may better mimic pathological situations exhibiting overexpression of FAK. In different scenarios, the membrane-bound chimeras and SuperFAK may be utilized to study the role of aberrant FAK signaling, alone or in combination with other signaling partners, in the development of human disease.

ACKNOWLEDGMENTS

We thank Drs. Tom Parsons, Sally Parsons, André Veillette, Paul Bates for providing reagents. We thank Dr. Erik Schaefer for helpful discussions during the course of this study. We are thankful to Jill Dunty and Patrick Lyons for critical reading of the manuscript and helpful comments during the course of this study. We also thank Dr. Patrick Crockett, Brian Lopes, and Tim Niecko for their help with the statistical analysis. This work was supported by the National Institutes of Health Grant CA90901 (to M.D.S). V.G-N. was supported by a pre-doctoral assistantship from the Department of Defense (DAMD17-00-1-0377).

REFERENCES

- 1 Almeida, E. A., Ilic, D., Han, Q., Hauck, C. R., Jin, F., Kawakatsu, H., Schlaepfer, D. D., and Damsky, C. H. (2000) *J.Cell Biol.* **149**, 741-754
- 2 Burgaya, F., Toutant, M., Studler, J. M., Costa, A., Le Bert, M., Gelman, M., and Girault, J. A. (1997) *J.Biol.Chem.* **272**, 28720-28725
- 3 Calalb, M. B., Polte, T. R., and Hanks, S. K. (1995) *Mol.Cell Biol.* **15**, 954-963
- 4 Cary, L. A., Chang, J. F., and Guan, J. L. (1996) *J.Cell Sci.* **109 (Pt 7)**, 1787-1794
- 5 Cary, L. A., Han, D. C., Polte, T. R., Hanks, S. K., and Guan, J. L. (1998) *J.Cell Biol.* **140**, 211-221
- 6 Chan, P. C., Lai, J. F., Cheng, C. H., Tang, M. J., Chiu, C. C., and Chen, H. C. (1999) *J.Biol.Chem.* **274**, 26901-26906
- 7 Chan, P. Y., Kanner, S. B., Whitney, G., and Aruffo, A. (1994) *J.Biol.Chem.* **269**, 20567-20574
- 8 Fincham, V. J., Brunton, V. G., and Frame, M. C. (2000) *Mol.Cell Biol.* **20**, 6518-6536
- 9 Fincham, V. J., Wyke, J. A., and Frame, M. C. (1995) *Oncogene* **10**, 2247-2252
- 10 Frisch, S. M., Vuori, K., Ruoslahti, E., and Chan-Hui, P. Y. (1996) *J.Cell Biol.* **134**, 793-799
- 11 Gilmore, A. P. and Romer, L. H. (1996) *Mol.Biol.Cell* **7**, 1209-1224
- 12 Han, D. C. and Guan, J. L. (1999) *J.Biol.Chem.* **274**, 24425-24430
- 13 Harte, M. T., Hildebrand, J. D., Burnham, M. R., Bouton, A. H., and Parsons, J. T. (1996) *J.Biol.Chem.* **271**, 13649-13655
- 14 Hildebrand, J. D., Schaller, M. D., and Parsons, J. T. (1993) *J.Cell Biol.* **123**, 993-1005
- 15 Hofstra, R. M., Landsvater, R. M., Ceccherini, I., Stulp, R. P., Stelwagen, T., Luo, Y., Pasini, B., Hoppener, J. W., van Amstel, H. K., and Romeo, G. (1994) *Nature* **367**, 375-376
- 16 Hungerford, J. E., Compton, M. T., Matter, M. L., Hoffstrom, B. G., and Otey, C. A. (1996) *J.Cell Biol.* **135**, 1383-1390
- 17 Igishi, T., Fukuhara, S., Patel, V., Katz, B. Z., Yamada, K. M., and Gutkind, J. S. (1999) *J.Biol.Chem.* **274**, 30738-30746
- 18 Ilic, D., Furuta, Y., Kanazawa, S., Takeda, N., Sobue, K., Nakatsuji, N., Nomura, S., Fujimoto, J., Okada, M., and Yamamoto, T. (1995) *Nature* **377**, 539-544
- 19 Johnson, L. N., Noble, M. E., and Owen, D. J. (1996) *Cell* **85**, 149-158
- 20 Keely, P. J., Fong, A. M., Zutter, M. M., and Santoro, S. A. (1995) *J.Cell Sci.* **108 (Pt 2)**, 595-607
- 21 Klemke, R. L., Leng, J., Molander, R., Brooks, P. C., Vuori, K., and Cheresch, D. A. (1998) *J.Cell Biol.* **140**, 961-972
- 22 Laemmli, U. K. (1970) *Nature* **227**, 680-685

- 23 Nagata, H., Worobec, A. S., Oh, C. K., Chowdhury, B. A., Tannenbaum, S., Suzuki, Y., and Metcalfe, D. D. (1995) *Proc.Natl.Acad.Sci.U.S.A* **92**, 10560-10564
- 24 Park, W. S., Dong, S. M., Kim, S. Y., Na, E. Y., Shin, M. S., Pi, J. H., Kim, B. J., Bae, J. H., Hong, Y. K., Lee, K. S., Lee, S. H., Yoo, N. J., Jang, J. J., Pack, S., Zhuang, Z., Schmidt, L., Zbar, B., and Lee, J. Y. (1999) *Cancer Res.* **59**, 307-310
- 25 Polte, T. R. and Hanks, S. K. (1995) *Proc.Natl.Acad.Sci.U.S.A* **92**, 10678-10682
- 26 Reiske, H. R., Kao, S. C., Cary, L. A., Guan, J. L., Lai, J. F., and Chen, H. C. (1999) *J.Biol.Chem.* **274**, 12361-12366
- 27 Ren, X. D., Kiosses, W. B., Sieg, D. J., Otey, C. A., Schlaepfer, D. D., and Schwartz, M. A. (2000) *J.Cell Sci.* **113 (Pt 20)**, 3673-3678
- 28 Reynolds, A. B., Roesel, D. J., Kanner, S. B., and Parsons, J. T. (1989) *Mol.Cell Biol.* **9**, 629-638
- 29 Santoro, M. M., Penengo, L., Minetto, M., Orecchia, S., Cilli, M., and Gaudino, G. (1998) *Oncogene* **17**, 741-749
- 30 Schaller, M. D. (2001) *Biochim.Biophys.Acta* **1540**, 1-21
- 31 Schaller, M. D., Borgman, C. A., Cobb, B. S., Vines, R. R., Reynolds, A. B., and Parsons, J. T. (1992) *Proc.Natl.Acad.Sci.U.S.A* **89**, 5192-5196
- 32 Schaller, M. D., Borgman, C. A., and Parsons, J. T. (1993) *Mol.Cell Biol.* **13**, 785-791
- 33 Schaller, M. D., Hildebrand, J. D., and Parsons, J. T. (1999) *Mol.Biol.Cell* **10**, 3489-3505
- 34 Schaller, M. D., Hildebrand, J. D., Shannon, J. D., Fox, J. W., Vines, R. R., and Parsons, J. T. (1994) *Mol.Cell Biol.* **14**, 1680-1688
- 35 Schaller, M. D. and Parsons, J. T. (1995) *Mol.Cell Biol.* **15**, 2635-2645
- 36 Schlaepfer, D. D., Hanks, S. K., Hunter, T., and van der, G. P. (1994) *Nature* **372**, 786-791
- 37 Schlaepfer, D. D. and Hunter, T. (1996) *Mol.Cell Biol.* **16**, 5623-5633
- 38 Schlaepfer, D. D. and Hunter, T. (1997) *J.Biol.Chem.* **272**, 13189-13195
- 39 Schlaepfer, D. D., Jones, K. C., and Hunter, T. (1998) *Mol.Cell Biol.* **18**, 2571-2585
- 40 Shen, Y. and Schaller, M. D. (1999) *Mol.Biol.Cell* **10**, 2507-2518
- 41 Shen, Y., Schneider, G., Cloutier, J. F., Veillette, A., and Schaller, M. D. (1998) *J.Biol.Chem.* **273**, 6474-6481
- 42 Shu, H. K., Pelley, R. J., and Kung, H. J. (1990) *Proc.Natl.Acad.Sci.U.S.A* **87**, 9103-9107
- 43 Smith, D. B. and Johnson, K. S. (1988) *Gene* **67**, 31-40
- 44 Sonoda, Y., Matsumoto, Y., Funakoshi, M., Yamamoto, D., Hanks, S. K., and Kasahara, T. (2000) *J.Biol.Chem.* **275**, 16309-16315

- 45 Thomas, J. W., Ellis, B., Boerner, R. J., Knight, W. B., White, G. C., and Schaller, M. D. (1998) *J.Biol.Chem.* **273**, 577-583
- 46 Thomas, S. M., Soriano, P., and Imamoto, A. (1995) *Nature* **376**, 267-271
- 47 Toutant, M., Studler, J. M., Burgaya, F., Costa, A., Ezan, P., Gelman, M., and Girault, J. A. (2000) *Biochem.J.* **348 Pt 1**, 119-128
- 48 Vuori, K., Hirai, H., Aizawa, S., and Ruoslahti, E. (1996) *Mol.Cell Biol.* **16**, 2606-2613
- 49 Webster, M. K., D'Avis, P. Y., Robertson, S. C., and Donoghue, D. J. (1996) *Mol.Cell Biol.* **16**, 4081-4087
- 50 Webster, M. K. and Donoghue, D. J. (1996) *EMBO J.* **15**, 520-527
- 51 Xu, L. H., Owens, L. V., Sturge, G. C., Yang, X., Liu, E. T., Craven, R. J., and Cance, W. G. (1996) *Cell Growth Differ.* **7**, 413-418
- 52 Young, J. A., Bates, P., and Varmus, H. E. (1993) *J.Virol.* **67**, 1811-1816
- 53 Zhang, X., Chattopadhyay, A., Ji, Q. S., Owen, J. D., Ruest, P. J., Carpenter, G., and Hanks, S. K. (1999) *Proc.Natl.Acad.Sci.U.S.A* **96**, 9021-9026
- 54 Zhao, J. H., Reiske, H., and Guan, J. L. (1998) *J.Cell Biol.* **143**, 1997-2008

ABBREVIATIONS

Abbreviations used: FAK, focal adhesion kinase; SH, Src homology; PI3K, phosphatidylinositol 3-kinase; PLC- γ 1, phospholipase C- γ 1; Grb, growth factor receptor bound; Shc, Src homology containing protein; FRNK, FAK-related non-kinase; CHO, Chinese hamster ovary; p130^{cas}, p130 crk-associated substrate; DMSO, dimethyl sulfoxide; ECM, extracellular matrix; FGFR3, fibroblast growth factor receptor type 3; PCR, polymerase chain reaction; CE, chicken embryo; RIPA, radioimmunoprecipitation; PMSF, phenylmethylsulfonylfluoride; PY, phosphotyrosine; TBS, Tris-buffered saline; GST, glutathione S-transferase; EGFR, epidermal growth factor receptor; V, valine; I, isoleucine; ATP, adenosine triphosphate; K, lysine; E, glutamic acid; M, methionine; T, threonine; Y, tyrosine; MAPK, mitogen-activating protein kinase; PBS, phosphate buffered saline; F, phenylalanine; ERK, extracellular signal-regulated kinases; MEK, MAPK/ERK kinase; FAT, focal adhesion targeting sequence.

FIGURE LEGENDS

Figure 1. Construction of Activated Mutants of FAK. **A**, The sequence of the activation loop of the kinase domain of FAK is shown. In SuperFAK two lysine residues, K578 and K581 (K) were substituted with glutamic acids (E), mimicking the activating K650E mutation in the FGFR3 [50]. Y576E/Y577E represents an additional mutant in which the regulatory tyrosine residues (Y576 & Y577) in the activation loop of FAK (Y) were mutated to glutamic acid (E). **B**, A schematic diagram of FAK is shown. Proline-rich regions (P), sites of tyrosine phosphorylation (Y) and the focal adhesion targeting (FAT) sequence are shown. Two additional FAK mutants were engineered to mimic activating point mutations in EGFR (V436I; ○○○) [42] and RET, Met/HGF/SFR, Ron/RMSH, and Kit kinases (M589T; ●●●) [15,23,24,29]. **C**, FAK6.7, an alternatively spliced neuronal form of FAK [2], contains two additional exons (6 & 7; gray boxes) flanking the autophosphorylation tyrosine on FAK, Y397.

Figure 2. Expression and *In Vitro* Kinase Activity. **A**, Expression of FAK and the FAK mutants was detected by Western blot analysis. Seven to 10 days after transfection, lysates (25 μ g) of CE cells expressing empty vector (*lane 1*), FAK (*lane 2*), SuperFAK (*lane 3*) or FAK6.7 (*lane 4*) were Western blotted with a FAK polyclonal antibody, BC4. **B**, The *in vitro* autophosphorylation activity of wild type FAK and the FAK mutants was determined using an immune complex kinase assay. FAK was immunoprecipitated from CE cell lysates (0.5-1 mg) expressing vector alone (*lane 1*), FAK (*lane 2*), SuperFAK (*lane 3*) or FAK6.7 (*lane 4*), using a polyclonal FAK antibody, BC4. The immune complexes were incubated in kinase buffer containing 32 P- γ ATP for 3 or 10 minutes. The

samples were subjected to SDS-PAGE and visualized by autoradiography (*top panel*). The immune complexes were also Western blotted using a polyclonal FAK antibody, BC4, to ensure equal loading (*bottom panel*). The positions of the molecular weight markers are indicated on the left.

Figure 3. Elevated substrate phosphorylation in SuperFAK and FAK6.7 overexpressors. **A**, Lysates (25 μ g) of CE cells expressing empty vector (*lane 1*), FAK (*lane 2*), SuperFAK (*lane 3*) or FAK6.7 (*lane 4*) were Western blotted with a phosphotyrosine antibody, RC20 (*top panel*). The positions of the molecular weight markers are indicated on the left. The same lysates (25 μ g) were Western blotted with a polyclonal FAK antibody, BC4, to ensure equal expression of FAK protein (*bottom panel*). **B-E**, FAK (**B**), tensin (**C**), paxillin (**D**) and p130^{cas} (**E**) were immunoprecipitated from CE cells (0.5-1 mg) expressing vector alone (*lane 1*), FAK (*lane 2*), SuperFAK (*lane 3*) or FAK6.7 (*lane 4*). The immune complexes were Western blotted with a phosphotyrosine antibody, RC20 (**B-E**; *top panels*). The nitrocellulose membranes were stripped and re-probed for FAK, tensin, paxillin and p130^{cas} to ensure equal amounts of protein were being analyzed (**B-E**; *bottom panels*).

Figure 4. Adhesion-mediated regulation of FAK signaling and kinase activity. **A**, The cellular phosphotyrosine content of CE cells expressing vector alone (*lanes 1-2*), FAK (*lanes 3-4*), SuperFAK (*lanes 5-6*) or FAK6.7 (*lanes 7-8*) was analyzed from cells kept in culture (Cul; *lanes 1, 3, 5, 7*) and from cells held in suspension for 45 min (Su; *lanes 2, 4, 6, 8*). The lysates (25 μ g) were Western blotted using a phosphotyrosine

antibody, RC20 (*top panel*). The same lysates (25 μ g) were Western blotted with a polyclonal FAK antibody, BC4, to ensure equal expression of FAK protein (*bottom panel*). **B**, The kinase activity of the FAK mutants upon loss of cell adhesion was analyzed using an immune complex kinase assay. FAK was immunoprecipitated from CE cells (0.5-1 mg) expressing empty vector (*lanes 1-2*), FAK (*lanes 3-4*), SuperFAK (*lanes 5-6*) or FAK6.7 (*lanes 7-8*) using a polyclonal FAK antibody, BC4. The immune complexes were incubated in kinase buffer containing 32 P- γ ATP for 5 min. The samples were separated by 8% SDS-PAGE and 32 P incorporation was analyzed by autoradiography (*top panel*). The immune complexes were also Western blotted with a polyclonal FAK antibody, BC4, to ensure equal amounts of protein were being analyzed (*bottom panel*). The positions of the molecular weight markers are indicated on the left.

Figure 5. Physiological elevation of paxillin phosphorylation. The phosphorylation of the FAK substrate, paxillin, was analyzed upon cell adhesion to fibronectin. Paxillin was immunoprecipitated from CE cells (0.5-1 mg) expressing vector alone (*lanes 1-3*), FAK (*lanes 4-6*), SuperFAK (*lanes 7-9*) or FAK6.7 (*lanes 10-12*). The cells were either kept in culture (Cul; *lanes 1, 4, 7, 10*), held in suspension for 45 minutes (Su; *lanes 2, 5, 8, 11*), or allowed to re-attach to fibronectin coated dishes for 30 minutes (*lanes 3, 6, 9, 12*). The paxillin immune complexes were Western blotted with a phosphotyrosine antibody, RC20 (*top panel*). The nitrocellulose membranes were stripped and re-probed with a monoclonal paxillin antibody to ensure equal amounts of paxillin were being analyzed (*bottom panel*).

Figure 6. Phosphorylation of Y397 and FAK-Src complex formation. **A,** The phosphorylation level of Y397 on FAK was analyzed by western blotting. Lysates (25 μ g) from CE cells expressing vector alone (*lane 1*), FAK (*lane 2*), Y397F FAK (*lane 3*), SuperFAK (*lane 4*) or FAK6.7 (*lane 5*) were western blotted with a FAK PY397 phosphospecific polyclonal antibody (*top panel*). Y397F FAK was used as a negative control for antibody specificity (*lane 3*). The nitrocellulose membrane was stripped and re-probed with a polyclonal FAK antibody, BC4, to ensure equal loading (*bottom panel*).

B, The association of the Src SH2 domain with FAK *in vitro* was analyzed. CE cells (0.5 mg) expressing vector alone (*lane 2*), FAK (*lanes 1,3*), SuperFAK (*lane 4*) or FAK6.7 (*lane 5*) were pre-cleared with GST (20 μ g) for 1 hr at 4° C. The pre-cleared lysates were then incubated with GST-SrcSH2 domain fusion protein (2 μ g) for 2 hrs at 4° C. GST alone (2 μ g) was used to control for binding specificity (*lane 1*). Bound FAK was detected by Western blotting with a polyclonal FAK antibody, BC4 (*top panel*). To ensure equal expression of the FAK constructs, the same CE lysates (25 μ g), expressing the empty vector (*lane 2*), FAK (*lane 3*), SuperFAK (*lane 4*), or FAK6.7 (*lane 5*) were Western blotted with a polyclonal FAK antibody, BC4 (*bottom panel*).

C, The association between the FAK variants and Fyn *in vivo* was analyzed by co-immunoprecipitation. Fyn was immunoprecipitated using a polyclonal Fyn antibody from CE cell lysates (0.5 mg) expressing vector alone (*lane 2*), FAK (*lane 3*), SuperFAK (*lane 4*), or FAK6.7 (*lane 5*). As a control for antibody specificity, the secondary antibody was used alone in an immunoprecipitation reaction with lysate of FAK expressing CE cells (*lane 1*). The immune complexes were Western blotted with a polyclonal FAK antibody

(*top panel*). The nitrocellulose membrane was stripped and re-probed with a polyclonal Fyn antibody to ensure equal amounts of Fyn were immunoprecipitated (*bottom panel*).

Figure 7. Effect of Src inhibition on FAK kinase activity *in vitro*. The effects of PP2, a pharmacological inhibitor of Src, on FAK kinase activity was monitored using an immune complex kinase assay. **A**, FAK was immunoprecipitated from CE lysates (1 mg) expressing empty vector (*lanes 1-2*), FAK (*lanes 3-4*), or SuperFAK (*lanes 5-6*), using a polyclonal FAK antibody, BC4. The immune complexes were incubated in kinase buffer containing ^{32}P - γ ATP for 8 minutes in the presence (+) of 0.5 μM PP2 or vehicle alone (DMSO;-). **B**, Src was immunoprecipitated from CE lysates (1 mg) expressing Src^{527F}, using a monoclonal Src antibody, EC10. The Src (*lanes 1-2*) and FAK (*lanes 4-10*) immune complexes (isolated as in **A**) were incubated with 5 μg of acid denatured enolase in enolase kinase buffer containing ^{32}P - γ ATP in the presence (+) of 0.5 μM PP2 or vehicle alone (DMSO; -) for 13 minutes. As a control, a FAK immune complex was incubated in an autophosphorylation reaction in the absence of enolase (*lane 3*). All kinase reaction samples were subjected to SDS-PAGE and autoradiography. The position of Src (closed arrow head), FAK (open arrow) and enolase (closed arrow) are indicated. An underexposure of lanes 1 and 2 is shown in lanes 10 and 11. The positions of the molecular weight markers are indicated on the left. **C**, The FAK immune complexes were also Western blotted using a polyclonal FAK antibody, BC4, to ensure equal amounts of protein were being analyzed.

Figure 8. Phosphorylation status of Src in cells co-expressing FAK and Src. **A,** The phosphorylation status of the activation loop tyrosine (Y416) and the inhibitory tail tyrosine (Y527) in Src were analyzed by Western blotting. In order to ensure antibody specificity, CE cell lysates (25 μ g) overexpressing c-Src (*lane 1*) or Src with a Y527 to F substitution, Src^{527F}, (*lane 2*) were Western blotted with polyclonal Src phosphospecific antibodies against phosphorylated Y416 (PY416; *top panel*) or phosphorylated Y527 (PY527; *middle panel*). The nitrocellulose membrane was stripped and re-probed with a monoclonal Src antibody, EC10, to ensure equal expression (*bottom panel*). **B,** CE cell lysates (25 μ g) co-expressing c-Src and vector alone (*lane 1*), FAK (*lane 2*), SuperFAK (*lane 3*) or FAK6.7 (*lane 4*) were western blotted with a Src activation loop phosphospecific tyrosine antibody, PY416 (*top panel*), or a Src inhibitory tail phosphospecific tyrosine antibody, PY527 (*second panel*). The nitrocellulose membranes were stripped and re-probed with a monoclonal Src antibody, EC10 (*third panel*), or a polyclonal FAK antibody, BC4 (*bottom panel*), to ensure equal amounts of protein were being analyzed.

Figure 9. Phosphorylation of Y925 is increased in cells expressing SuperFAK. The phosphorylation status of Y925 on FAK was analyzed using an *in vitro* binding assay. CE cells expressing empty vector (*lane 2*), FAK (*lanes 1, 3*), SuperFAK (*lane 4*) or FAK6.7 (*lane 5*) were treated overnight with vanadate (50 μ M) then lysed. The CE lysates (1 mg) were pre-cleared with GST (20 μ g) for 1 hr at 4^o C. Pre-cleared lysates were then incubated with a GST-Grb2SH2 fusion protein (*lanes 2-5*) or GST alone (*lane 1*). Bound FAK was detected by Western blotting with a polyclonal FAK antibody, BC4 (*top*

panel). The same lysates (25 μ g) were Western blotted with a polyclonal FAK antibody, BC4, to ensure equal expression of the FAK constructs (*bottom panel*).

Figure 10. Elevation of T47D/Tva motility in cells expressing FAK or SuperFAK. A,

The expression of the FAK proteins in T47D/Tva cells 10 days after infection was analyzed by Western blotting. Lysates (25 μ g) of T47D/Tva cells infected with the empty retroviral vector (*lane 1*), or retrovirus containing the FAK (*lane 2*), SuperFAK (*lane 3*), or FAK6.7 (*lane 4*) cDNAs were western blotted with a polyclonal FAK antibody, BC4. The positions of the molecular weight markers are indicated on the left. **B,** The motility of T47D/Tva cells expressing empty vector (mock), FAK, SuperFAK or FAK6.7 was measured in a transwell system. Cells were allowed to migrate to the underside of a collagen coated transwell membrane for 20-22 hrs. The number of cells that reached the underside of the membrane were counted. The average fold change in migration from 11 experiments is shown \pm standard error. The difference in motility between FAK and mock, and SuperFAK and mock were statistically significant ($p < 0.05$).

Figure 1

A.

SuperFAK

(K578E/K581E)

DFGLSRYMEDST⁵⁷⁶YY⁵⁷⁸K⁵⁸¹AS⁵⁷⁷K⁵⁸⁰GKLPKWMAP⁹²⁵E Activation Loop

Y576E/Y577E

B.

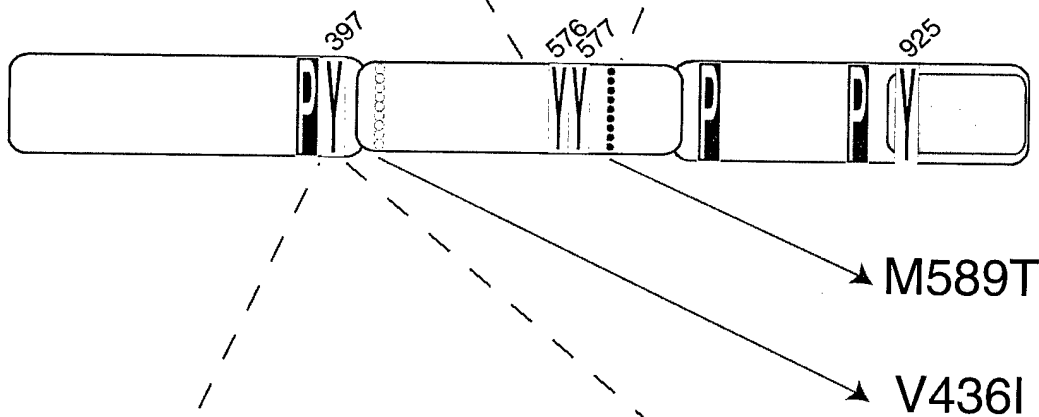

C.

TVSVS⁶**DISCD**ETDD³⁹⁷YAEIIDEEDTYTMP⁷S**KSYCID**TRDYE

FAK6.7

Figure 2

A.

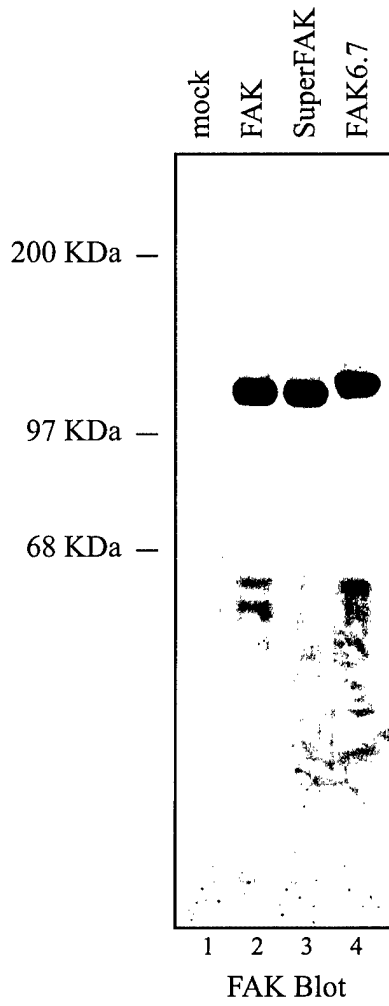

B.

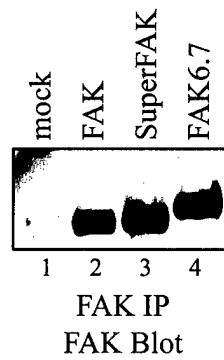
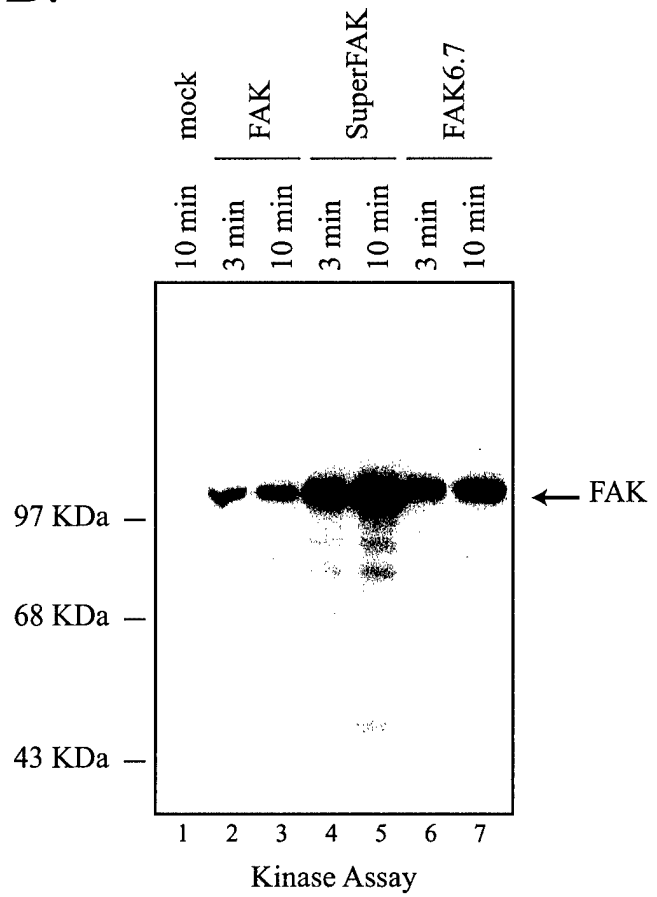

Figure 3

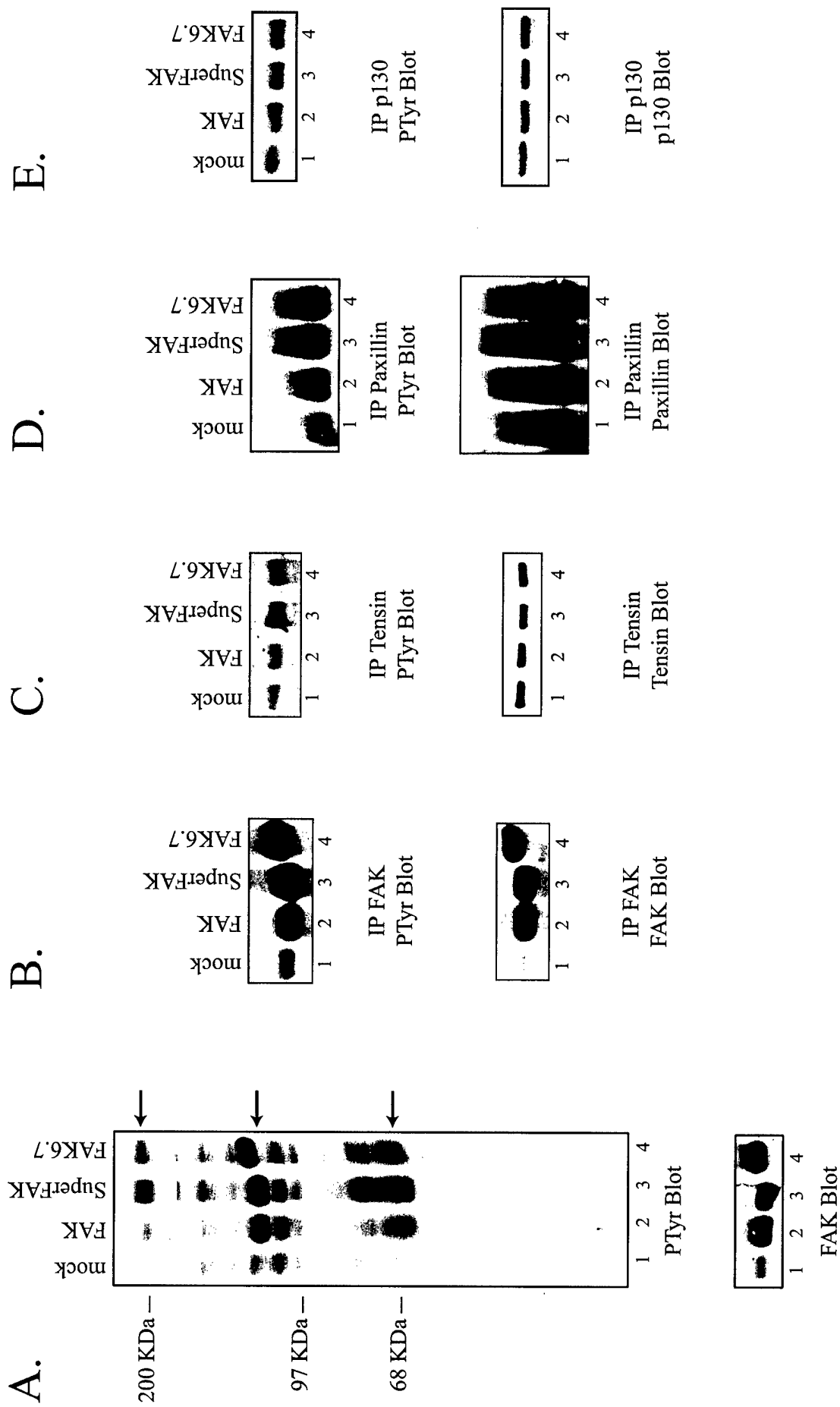
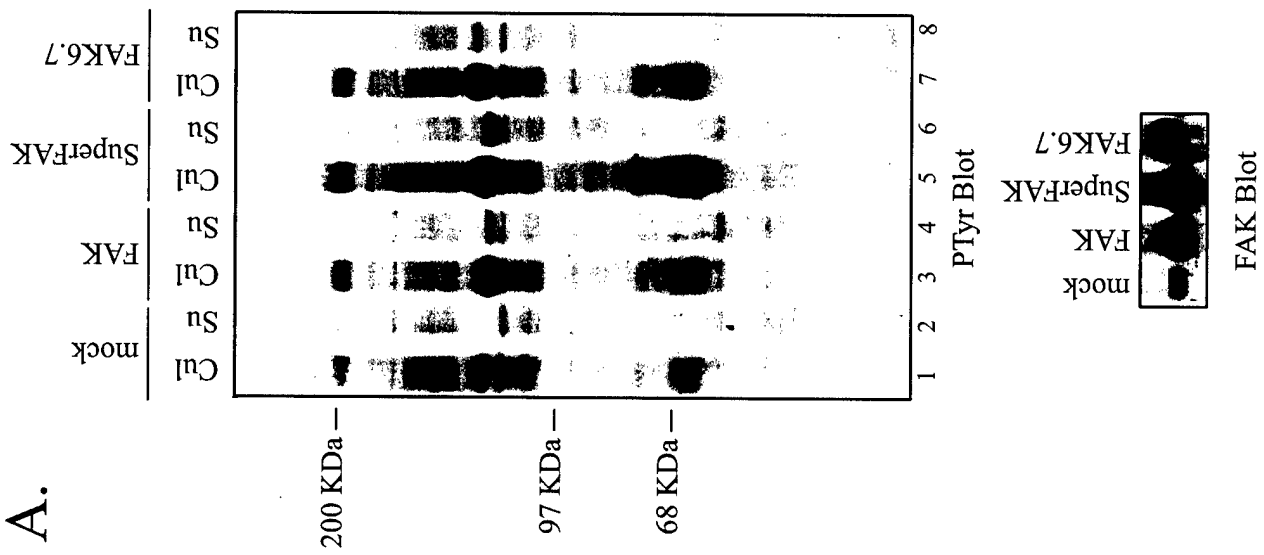

Figure 4

A.



B.

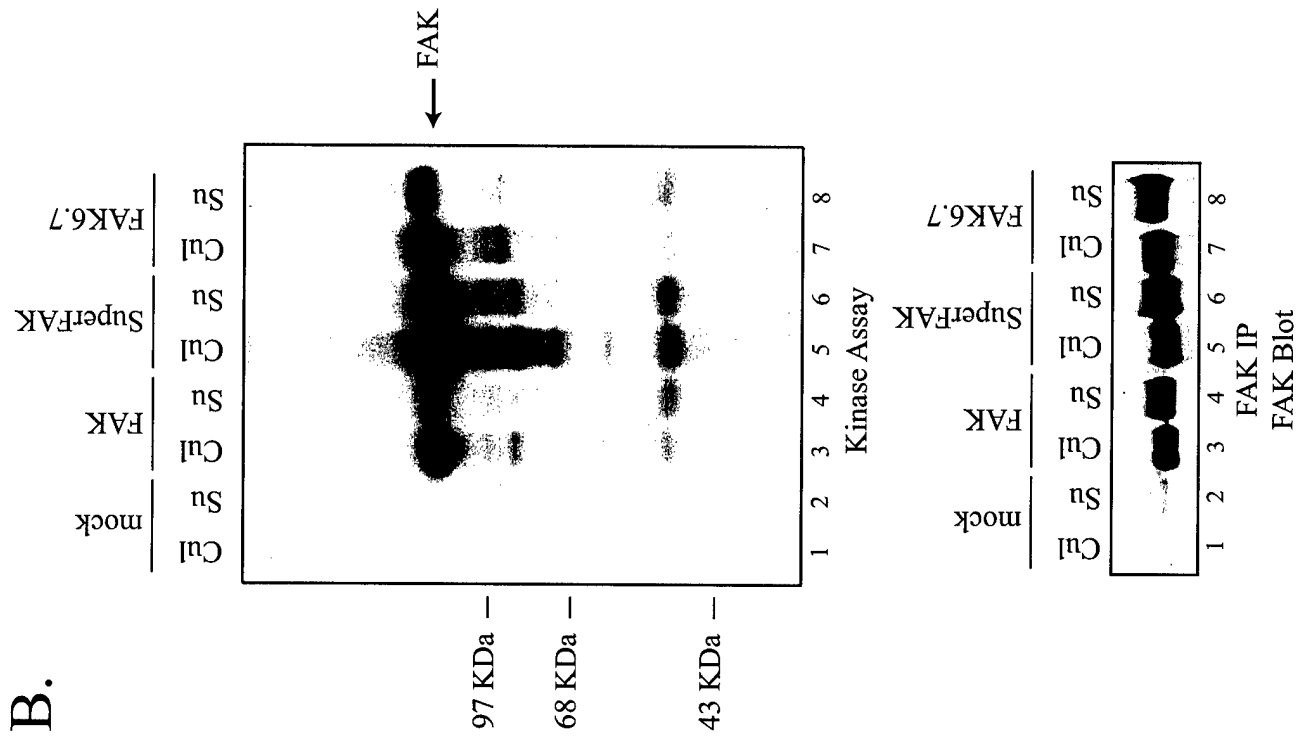
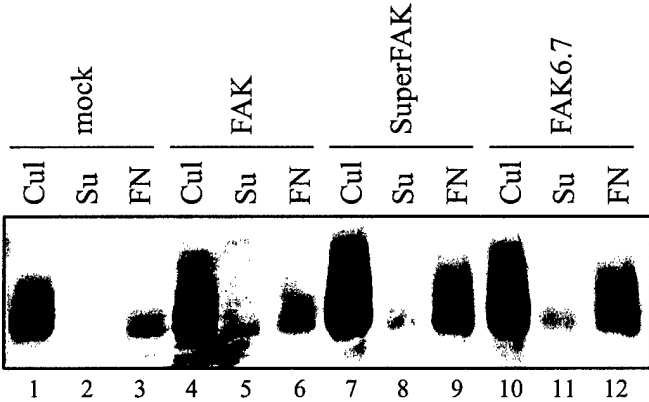
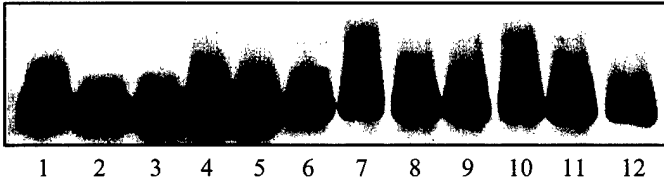

Figure 5



IP Paxillin
PTyr Blot



IP Paxillin
Paxillin Blot

Figure 6

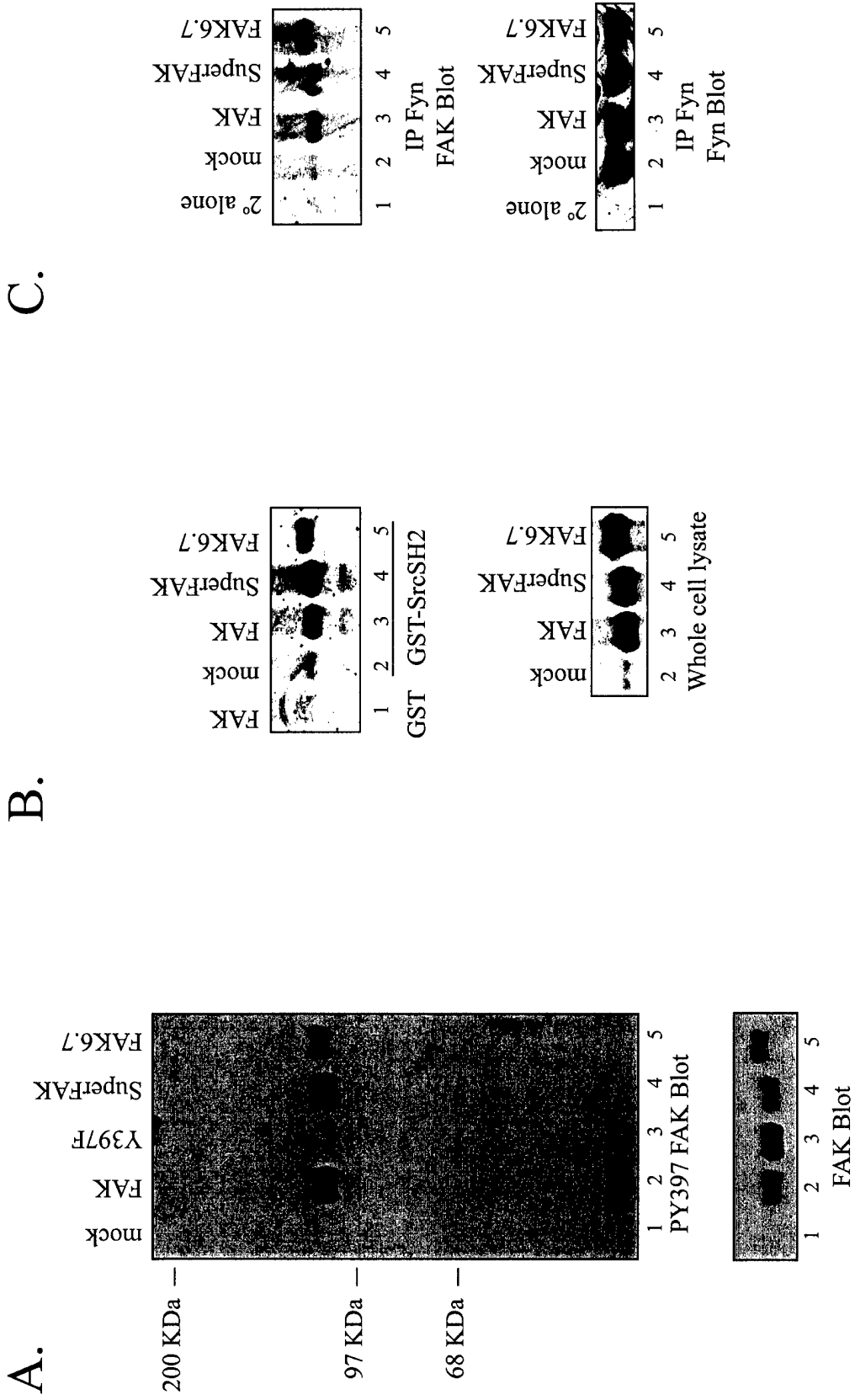

Figure 7

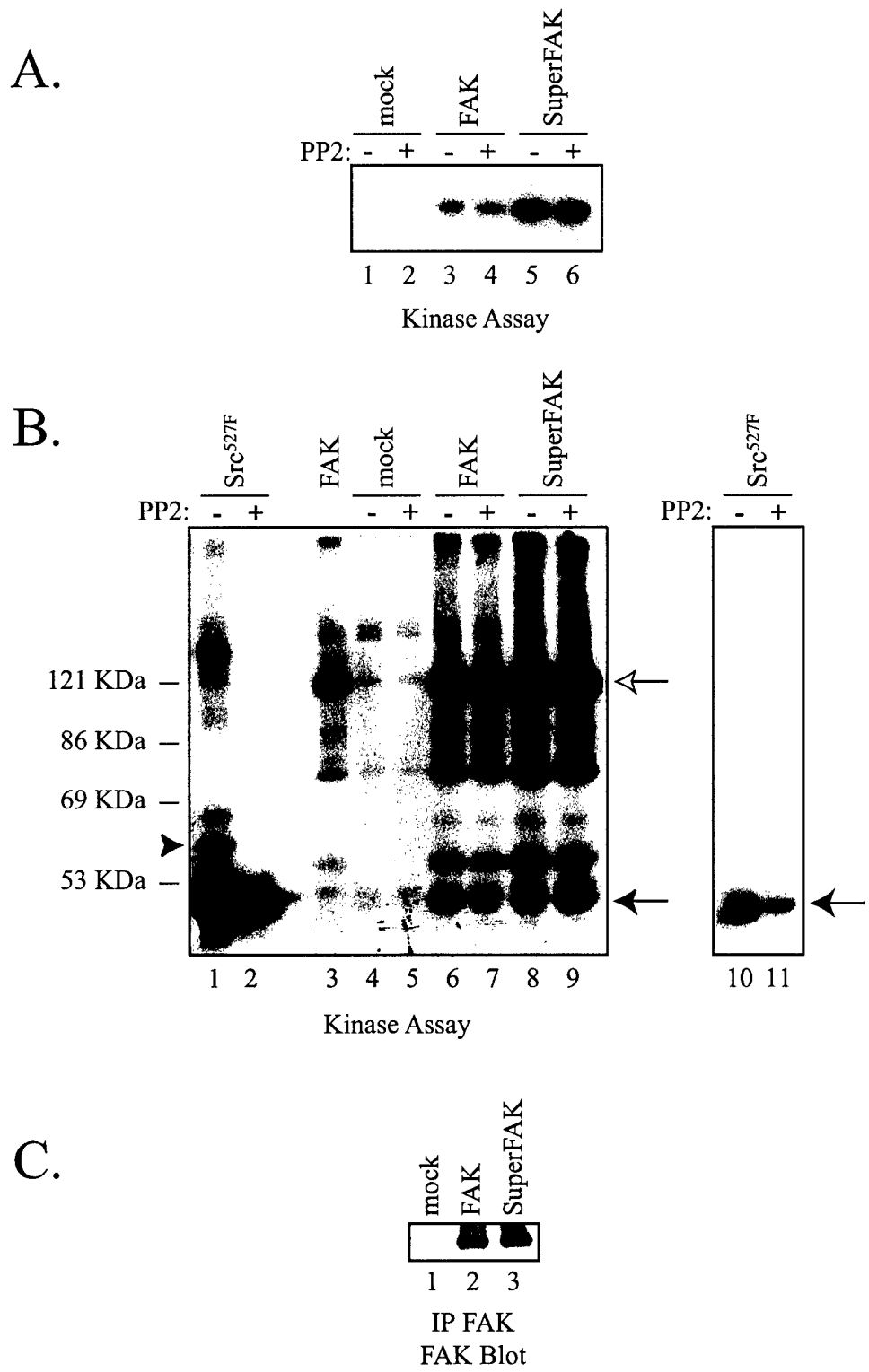
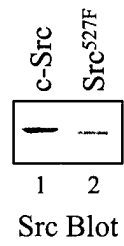
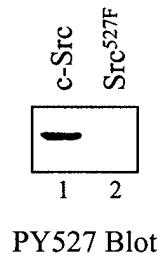
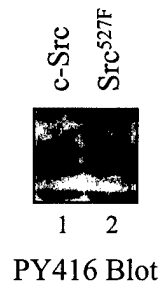

Figure 8

A.



B.

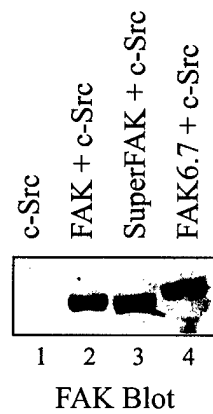
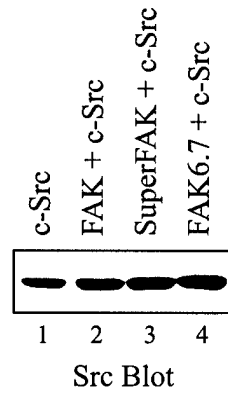
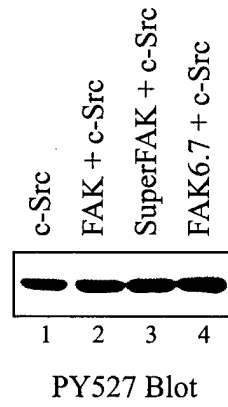
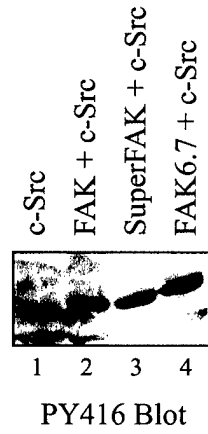

Figure 9

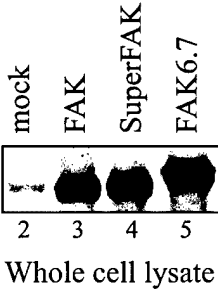
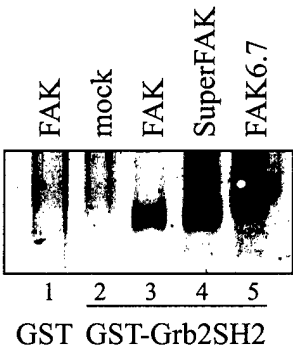
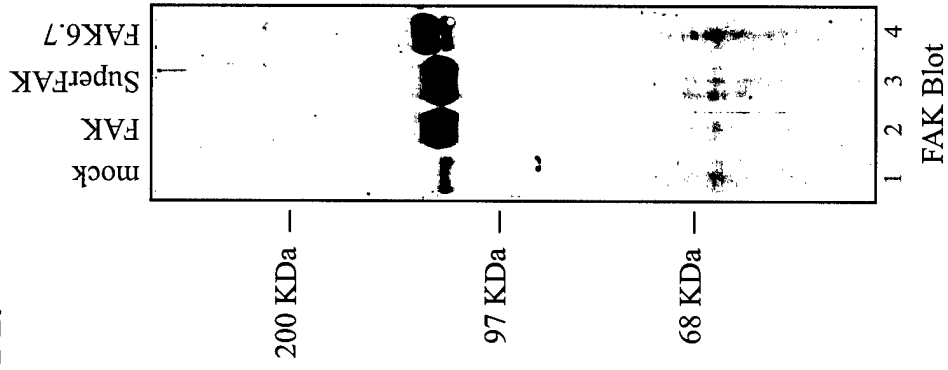
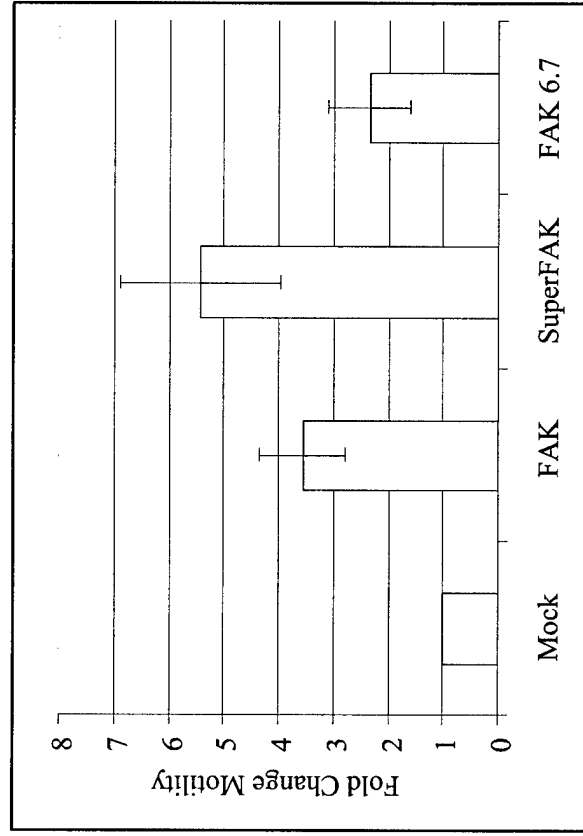

Figure 10

A.



B.



APPENDIX C

Joint UNC-CH and Duke Cell and Developmental Biology Retreat Abstract

Southern Pines, NC

April 5-7, 2002

ROLE OF FAK SIGNALING IN THE ACQUISITION OF CANCER PHENOTYPES IN BREAST EPITHELIAL CELLS

Veronica Gabarra-Niecko¹, Michael D. Schaller^{1,2}

¹Department of Cell and Developmental Biology, and ²Lineberger Comprehensive Cancer Center, University of North Carolina, Chapel Hill, NC27599

FAK is a non-receptor tyrosine kinase that functions in normal biological processes such as adhesion, spreading, migration, motility, cell cycle, and cell survival. Tyrosine kinases play an important role in cancer. Elevated src activity has been observed in a variety of human cancers, including colon and breast cancer. Src binds and phosphorylates FAK, suggesting that FAK may function in src transformation. FAK itself is overexpressed in a variety of cancer cells and tumors, including breast cancer tumors. Elevated FAK expression correlates with highly motile cells and tumor invasiveness, suggesting that FAK might be involved in the progression of cancer cells to a more invasive phenotype. Targeting a CD2/FAK chimera to the membrane, leads to constitutive FAK activation. Interestingly, expression of CD2FAK in MDCK cells confers anchorage independent growth and the ability to form tumors in nude mice. Since FAK is overexpressed in breast cancer, and FAK is known to regulate cell cycle, motility and survival, we hypothesize that enhanced FAK signaling is an important event in the acquisition of a cancerous phenotype. In order to test this hypothesis, wild type and constitutively activated FAK were expressed in MCF10A, normal breast epithelial cells, to study the consequences of enhanced FAK signaling. Conversely, the naturally occurring dominant negative form of FAK was used to inhibit FAK signaling in T47D, a breast cancer cell line. The T47D cells were monitored for loss of transformation phenotypes, indicating rescue of a normal phenotype.

APPENDIX D
Experimental Biology Meeting Presentation

Molecular and structural analysis of the Focal Adhesion Kinase.

M. D. Schaller¹, V. Gabarra¹, M. King-Brantley¹, G. Gao², K. Prutzman², S. L. Campbell².

¹Department of Cell & Developmental Biology, University of North Carolina, Box 7090, Chapel Hill, NC 27599, ²Department of Biochemistry & Biophysics, University of North Carolina, Chapel Hill, NC

FAK is a major component of an integrin regulated signal transduction pathway and has been implicated in the transmission of a cell adhesion dependent signal required for optimal signal transduction via growth factor receptors. The interplay between FAK and the EGF receptor family of tyrosine kinases may be particularly relevant in mammary gland epithelial cells and the development of breast cancer. Enhancement of FAK signaling in breast epithelial/cancer cell lines by expression of a hyperactive mutant or inhibition of endogenous FAK signaling alters cellular phenotypes, including motility and growth in soft agar, supporting the hypothesis that aberrant FAK signaling may contribute to the development of breast cancer. We are currently using this system to explore interactions between FAK and the EGF receptor family and the molecular basis for FAK signaling in epithelial cells. In addition, we have recently undertaken a structural analysis to elucidate the structural basis for the interaction of FAK with its binding partners and for FAK function. This project is supported by grants from the National Institutes of Health (GM53666 and CA90901).