

**REPORT DOCUMENTATION PAGE**

Form Approved  
OMB No. 0704-0188

The public reporting burden for this collection of information is estimated to average 1 hour per response, including the time for reviewing instructions, searching existing data sources, gathering and maintaining the data needed, and completing and reviewing the collection of information. Send comments regarding this burden estimate or any other aspect of this collection of information, including suggestions for reducing the burden, to Department of Defense, Washington Headquarters Services, Directorate for Information Operations and Reports (0704-0188), 1215 Jefferson Davis Highway, Suite 1204, Arlington, VA 22202-4302. Respondents should be aware that notwithstanding any other provision of law, no person shall be subject to any penalty for failing to comply with a collection of information if it does not display a currently valid OMB control number.

**PLEASE DO NOT RETURN YOUR FORM TO THE ABOVE ADDRESS.**

<b>1. REPORT DATE (DD-MM-YYYY)</b> 7/29/02		<b>2. REPORT TYPE</b> Final Technical Report		<b>3. DATES COVERED (From - To)</b> 3/1/1997 - 9/30/2001	
<b>4. TITLE AND SUBTITLE</b> The logic of Computation in Biological Regulatory Networks				<b>5a. CONTRACT NUMBER</b>	
				<b>5b. GRANT NUMBER</b> N00014-97-1-0293	
				<b>5c. PROGRAM ELEMENT NUMBER</b>	
<b>6. AUTHOR(S)</b> Jehoshua Bruck Paul Sternberg				<b>5d. PROJECT NUMBER</b>	
				<b>5e. TASK NUMBER</b>	
				<b>5f. WORK UNIT NUMBER</b>	
<b>7. PERFORMING ORGANIZATION NAME(S) AND ADDRESS(ES)</b> California Institute of Technology Pasadena, CA 91125				<b>8. PERFORMING ORGANIZATION REPORT NUMBER</b> PWS.61288-1-ONR.612880	
<b>9. SPONSORING/MONITORING AGENCY NAME(S) AND ADDRESS(ES)</b> Office of Naval Research				<b>10. SPONSOR/MONITOR'S ACRONYM(S)</b> ONR	
				<b>11. SPONSOR/MONITOR'S REPORT NUMBER(S)</b>	
<b>12. DISTRIBUTION/AVAILABILITY STATEMENT</b> Distribution Unlimited					
<b>13. SUPPLEMENTARY NOTES</b>					
20020822 055					
<b>14. ABSTRACT</b> Our goal in this project was to study, formalize and model biological regulatory processes and explore potential computational paradigms that are inspired by those new abstractions. We focused on developing appropriate level models for gene regulation, intercellular signaling and signal transduction mechanisms using the vast amount of information on the development and the behavior of organisms. In conjunction, to the efforts to better understand biological systems we focused on abstracting and extracting novel ideas from biology that can improve the state of the art in information systems. We combine expertise in an intensively studied developmental model system, <i>Caenorhabditis Elegans</i> ( <i>C. Elegans</i> ) vulval induction and in the study of the computational and structural capabilities and limitations in Boolean and threshold logic circuits as well as in parallel and distributed systems. Our hierarchical approach to modeling starts with models that address the kinetic and circuit level representations and follows with abstract functional system models like finite state automata and asynchronous feedback circuits.					
<b>15. SUBJECT TERMS</b> Gene regulation, signal transduction, feedback circuits, stochastic simulation, biological control modules					
<b>16. SECURITY CLASSIFICATION OF:</b>			<b>17. LIMITATION OF ABSTRACT</b>	<b>18. NUMBER OF PAGES</b>	<b>19a. NAME OF RESPONSIBLE PERSON</b>
<b>a. REPORT</b>	<b>b. ABSTRACT</b>	<b>c. THIS PAGE</b>			Jehoshua Bruck
U	U	U	UP	35	<b>19b. TELEPHONE NUMBER (Include area code)</b> 626-395-2239

# The Logic of Computation in Biological Regulatory Networks

## Grant #: N000149710293

### Final Technical Report

PI's: Jehoshua Bruck and Paul W. Sternberg  
Caltech  
Pasadena CA 91125  
Email: {bruck,pws}@caltech.edu

**ONR Program Officer:** Ira Skurnick

**Dates Covered:** 3/1/1997 – 9/30/01

**Report Date:** 07-29-2002

#### OBJECTIVES AND APPROACH

Our goal in this project was to study, formalize and model biological regulatory processes and explore potential computational paradigms that are inspired by those new abstractions. We focused on developing appropriate level models for gene regulation, intercellular signaling and signal transduction mechanisms using the vast amount of information on the development and the behavior of organisms. In conjunction, to the efforts to better understand biological systems we focused on abstracting and extracting novel ideas from biology that can improve the state of the art in information systems.

We combine expertise in an intensively studied developmental model system, *Caenorhabditis Elegans* (*C. Elegans*) vulval induction and in the study of the computational and structural capabilities and limitations in Boolean and threshold logic circuits as well as in parallel and distributed systems. Our hierarchical approach to modeling starts with models that address the kinetic and circuit level representations and follows with abstract functional system models like finite state automata and asynchronous feedback circuits.

#### WORK COMPLETED AND ITS POTENTIAL IMPACT

The contributions of the project span results in biology, in the intersection of biology and engineering as well as in new engineering approaches to the design of circuits. The key contributions include:

- **The best known algorithms for simulating systems of weakly coupled chemical equations, related papers are [5, 6, 7 and 8]:**

Chemical equations occur in gene regulation and other biological systems. However, for small numbers of molecules (as in a small cell), the usual differential equations approach to chemical kinetics must be replaced with a stochastic approach. To deal with this kind of system, one

generates trajectories through stochastic phase space. By generating a large enough number of trajectories, one can understand the statistics of the behavior of the complex, non-linear system. The algorithms for dealing with sparsely connected stochastic processes are not as advanced as those for sparse deterministic processes. In particular, the existing algorithm of choice for generating trajectories, which is not optimized in any way for sparseness, is  $O(rE)$ , where  $r$  is the number of reactions and  $E$  is the number of reaction events in the trajectory. Our new algorithms are of  $O(r + E \log r)$  complexity. Our new algorithmic approach is quickly becoming the standard in simulation packages for gene regulatory processes.

- **Inspired by gene regulatory processes we study the role of feedback in the design of combinational circuits.**

All combinational circuits designed in practice are acyclic (feed-forward) networks. Our objective is to demonstrate that the number of gates can be reduced if feedback is used. This work is directly relevant for the design of electronic integrated circuits; we have created a circuit design optimization package and applied it on real circuits. We got very exciting results that show that feedback can significantly help in optimizing resources. A patent application on this approach is being prepared. Publications will follow after the patent submission. Appendix A is an overview of the work.

- **The Modeling and abstraction of the biphasic regulation in signal transduction that is provided by scaffolding proteins, related papers are [1,2, 3 and 4].**

We developed a generic model for the effect of "scaffolding" proteins on a major signal transduction pathway, the MAP kinase module. Using this model, we discovered how the properties of such a common pathway can be modified and tuned, including changing a sigmoidal input-output relationship to a graded relationship. The key mechanism that we discovered is called 'combinatorial inhibition'. Following the initial work on signal transduction we embarked upon a study of identifying and classifying regulatory models. This study is not published yet. We are enclosing an overview in Appendix B.

- **The first known automatic system for studying locomotion in *C. elegans*, that revealed a number of surprising facts about the biological system, related paper is [9].**

Our work on locomotion of *C. elegans* includes the creation of a novel system for automatically tracking the movement of the worm. Using this innovative tool we have discovered a fascinating fact about locomotion in *C. elegans*: that the worm moves at a distinct velocities. It has a "gear" system where it either moves at speed  $V$  (forward),  $-V$  (backward) or  $0$  (Parking). We also started studying the neural mechanism related to locomotion. The tracking tool is actively used in Sternberg's lab at Caltech and the work on the study of locomotion continues as part of a DARPA grant joint between JPL and Sternberg's lab.

## ORGANIZATION OF THE REST OF THE REPORT

The rest of the report is describing our unpublished work on circuits with feedback (Appendix A) and the study of biological regulatory modules (Appendix B).

## RELATED PUBLICATIONS

1. Levchenko, J. Bruck and P. W. Sternberg, "Combination of Biphasic Response Regulation and Positive Feedback as a General Regulatory Mechanism in Homeostasis and Signal Transduction," in *Foundations of Systems Biology*, edited by H. Kitano, 2001.
2. A. Levchenko, J. Bruck and P. Sternberg, "Scaffold Proteins May Biphasically Affect the Levels of Mitogen-Activated Protein Kinase Signaling and Reduce its Threshold Properties," *Proceedings on the National Academy of Sciences*, Vol. 97, No. 11, pages 5818-5823, May 2000.
3. Levchenko, J. Bruck and P. Sternberg, "Existence of Optimal Concentrations of the Members of MAPK Cascade: Implications for Signal Transduction Regulation," *Proc. of Keystone Research Conference: Signaling 2000*, January 2000.
4. A. Levchenko, J. Bruck and P. Sternberg, "The Role of Multimolecular Complex Formation in Regulation of MAPK Cascade Signaling: A Computer Assisted Theoretical Study," *Workshop on Computational Modeling of Biological Systems*, Hilton Head Island, February 2000.
5. M. Gibson and J. Bruck, "Efficient Exact Stochastic Simulation of Chemical Systems with Many Species and Many Channels," *Journal of Physical Chemistry A*, Vol. 104, No. 9, pages 1876-1889, March 2000.
6. M. Gibson, "Computational Methods for Stochastic Biological Systems," PhD. Dissertation, Caltech, June 2000.
7. M. Gibson and J. Bruck, "A Probabilistic Model of Prokaryotic Gene and its Regulation," in *Computational Methods in Molecular Biology: From Genotype to Phenotype*, Bolouri and Bower, eds., expected Fall 2000.
8. M. A. Gibson and J. Bruck, "Estimation of Stochastic Parameters," *The Fourth Annual International Conference on Computational Molecular Biology (REOMB)*, Tokyo, Japan, April 2000.
9. J. Mendel, S. Mukhtar, J. Bruck and P. Sternberg, "Worm Locomotion Described: A New Method for Extracting Quantitative Data on Movement Parameters," *2001 International Worm Meeting*, Los Angeles, CA, June 2001.

## **Appendix A:**

### **Computing with Feedback Circuits**

M. Riedel and J. Bruck

#### **Introduction**

We propose to investigate the role of feedback in the design of combinational digital circuits. All combinational circuits designed in practice are acyclic (feed-forward) networks. Our objective is to demonstrate that the number of gates can be reduced if feedback is used. This work is directly relevant for the design of electronic integrated circuits; however, the concepts may also be relevant for modeling chemical/biological systems in which feedback plays an important role.

#### **Background and Terminology**

For our purposes, a digital circuit may be described as a device which receives binary (i.e., zero or one) input values and computes binary output values.<sup>1</sup> Digital circuits can be classified as either *combinational* or *sequential*. In combinational circuits, the current outputs are computed based only on the current inputs. In sequential circuits, the current outputs may also depend on prior inputs. Thus, sequential circuits have memory elements and maintain a state. They are typically built using blocks of combinational logic and memory elements which are synchronized by a global clock, as shown in Fig. 1.

---

<sup>1</sup> This model can be readily generalized to the case of multi-valued logic, in which inputs and outputs assume integer values in some finite range  $[0..v-1]$ .

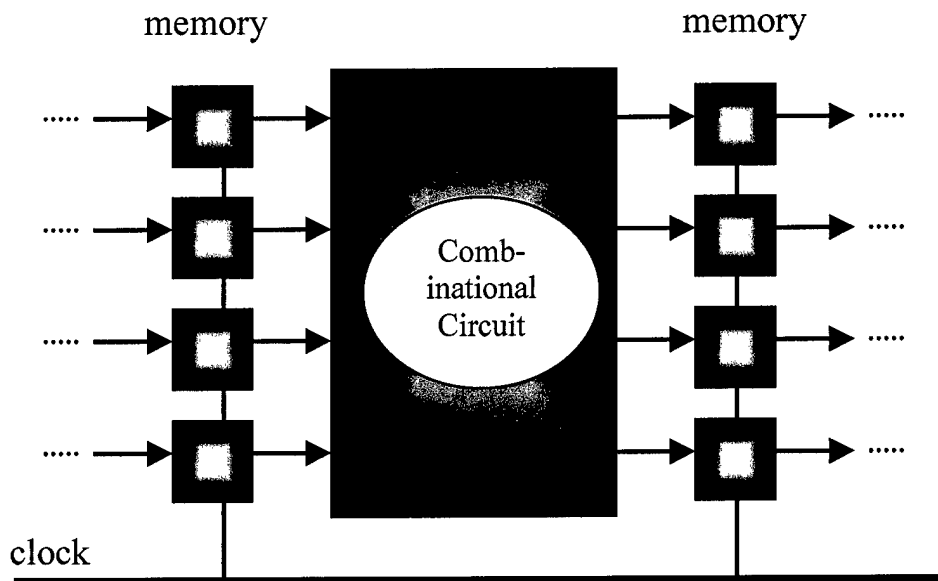

Figure 1 : Sequential circuit built from combinational blocks and memory.

Combinational circuits, in turn, are built from networks of logic *gates*. Each logic gate performs a mapping from a set of binary input values to a single binary output value. For instance, an AND gate, shown in Fig. 2, maps the input pairs  $\{0, 0\}$ ,  $\{0, 1\}$ ,  $\{1, 0\}$  and  $\{1, 1\}$  to 0, 0, 0 and 1, respectively. An OR gate, also shown in Fig 2, maps the input pairs  $\{0, 0\}$ ,  $\{0, 1\}$ ,  $\{1, 0\}$  and  $\{1, 1\}$  to 0, 1, 1 and 1, respectively. In general, a gate does not compute new values instantaneously; when a new set of inputs are applied, there is some delay, called the switching time, before it produces the corresponding output value.

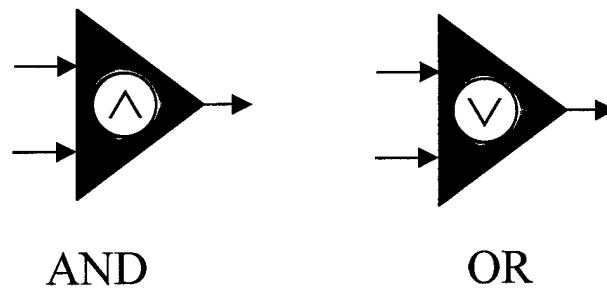

Figure 2: AND and OR logic gates.

In electronic integrated circuits, each gate is implemented with a small number of transistors (typically 2-4 transistors for a gate with two inputs). An important goal in the design of combinational circuitry is to minimize the number of gates, since the gate count correlates with the size of the circuit and hence its cost.

The requirement for a combinational circuit is that for every set of inputs the outputs are stable and uniquely determined. With an acyclic (i.e., feed-forward or tree-structured) network of gates, this requirement is clearly met: new values propagate from the inputs at the leaves of the tree to the outputs at the roots. An example of an acyclic circuit is shown in Fig. 3. If the inputs are held constant for a sufficient amount of time, the outputs stabilize at known values. The switching delay of the circuit is bounded by the sum of the delays along the longest path from an input to an output.

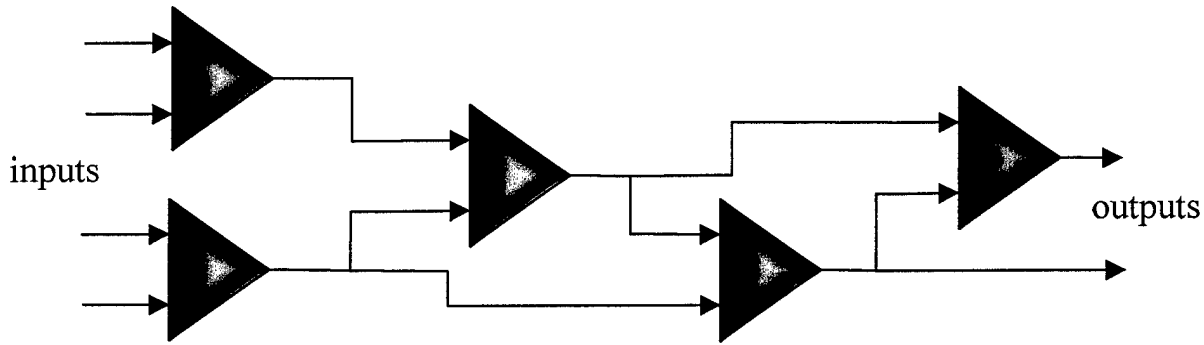

Figure 3 : Example of an acyclic circuit.

With a cyclic circuit, in contrast, the outputs might not be stable, or might not stabilize to known values, hence the circuit might not be combinational. Consider the circuit shown in Fig. 4, consisting of an AND gate and a NOR gate (i.e., an OR gate with the output inverted). For input values  $a=1$  and  $b=0$ , the output of the circuit oscillates between 0 and 1. Now consider the circuit shown in Fig. 5, consisting of an AND gate and an OR gate. For input values  $a=1$  and  $b=0$ , the output of the circuit is stable but unknown: it could be zero or one depending on the initial values on the wires.

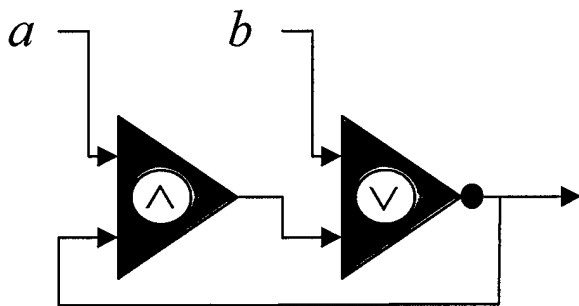

Figure 4: An unstable circuit for  $a=1, b=0$ .

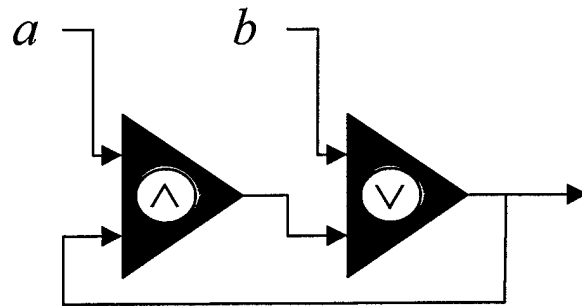

Figure 5: A circuit with an unknown output value for  $a=1, b=0$ .

And yet some cyclic circuits are combinational. Consider the example in Fig. 6, consisting of an AND gate and an OR gate. For either input value  $a=0$  or  $a=1$ , the circuit is stable and the output is a known value (it is equal to  $a$ ).

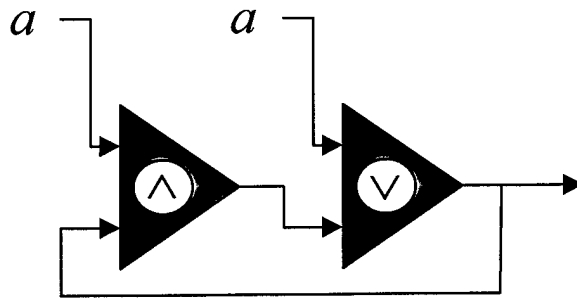

Figure 6: A combinational circuit.

### Prior Work

All combinational circuits designed in practice are acyclic. And yet, in 1970 Kautz presented an example of a cyclic combinational circuit with provably fewer gates than any equivalent acyclic circuit [1]. In 1977, Rivest provided a second example [2]. He described a combinational circuit with the following properties: for any odd integer  $n$  greater than 1, the circuit consists of  $n$  AND gates alternating with  $n$  OR gates in a single cycle, with  $n$  inputs repeated twice. The circuit for  $n=3$  is shown in Fig. 7. Rivest showed that the circuit is combinational (i.e., stable with uniquely determined outputs) and each gate computes a distinct output function. He also showed that the circuit is optimal in terms of the number of gates, and proved that any acyclic circuit that implements the same  $2n$  output functions requires at least  $3n - 2$  gates. Thus, feedback provides an asymptotic improvement factor of  $2/3$  in the number of gates.

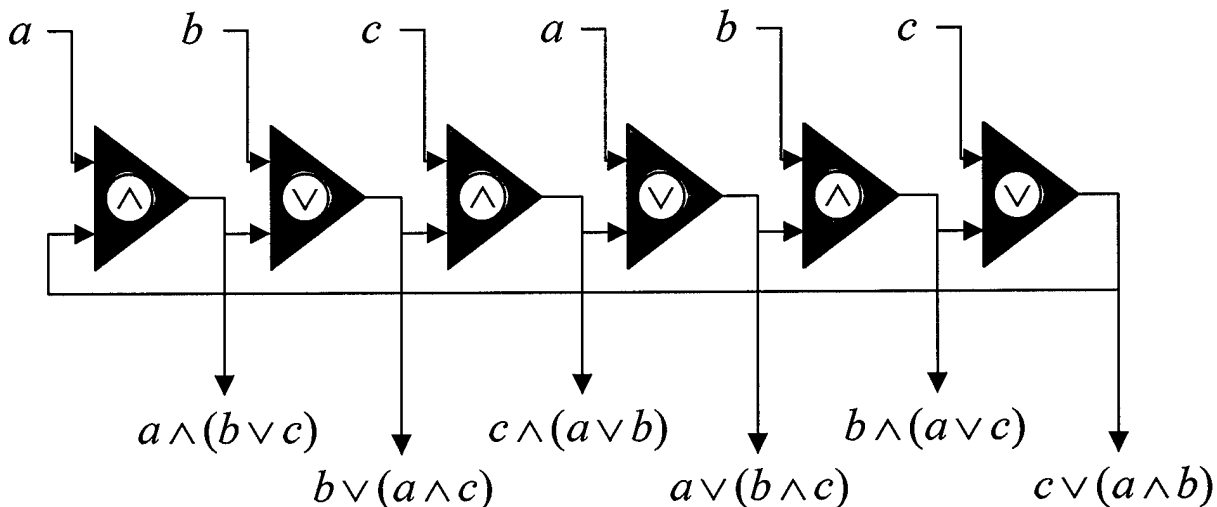

Figure 7: Cyclic combinational circuit due to Rivest.

Apart from the circuits presented by Rivest and Kautz, no further examples of combinational circuits were known in which feedback yields circuits with fewer gates.

## Results and Research Goals

We have developed a theoretical framework for the analysis of cyclic combinational circuits, based on the so-called Reed-Muller form in which functions are expressed using exclusive-or (XOR) and conjunction (AND) operations [3]. Within this framework, we have derived necessary and sufficient conditions for a cyclic circuit to be combinational.

Informally, the condition may be stated as follows: for every set of input values, each cycle must contain at least one "inert" wire. A wire is said to be inert if the logic gate to which it leads does not depend on its value. The output of the gate is determined by its other inputs. For instance, in the case of an AND gate, if one of the inputs is zero, all the other inputs are inert since the output of the gate is zero regardless of their value. In the case of an OR gate, if one of the inputs is one, all the other inputs are inert since the output of the gate is one regardless of their value. The key observation is that for each set of inputs, different wires in a circuit may be inert. Consider the example shown in Fig. 8. This circuit contains three cycles. For the assignment of input values,  $\{a = 0, b = 1\}$ , the wires drawn in red are inert. Similarly, for all other assignments, at least one wire in each cycle is inert, and so we conclude that the circuit is, indeed, combinational.

Based on the Reed-Muller framework, we have performed a computerized search for cyclic circuits. The search has yielded hundreds of single-cycle circuits with provably fewer gates than any equivalent acyclic circuits. We have also shown the existence of several multi-cycle circuits with the same property. Among these is a family of circuits with an asymptotic improvement factor of  $1/2$ , which beats the improvement factor of  $2/3$  of Rivest's circuit.

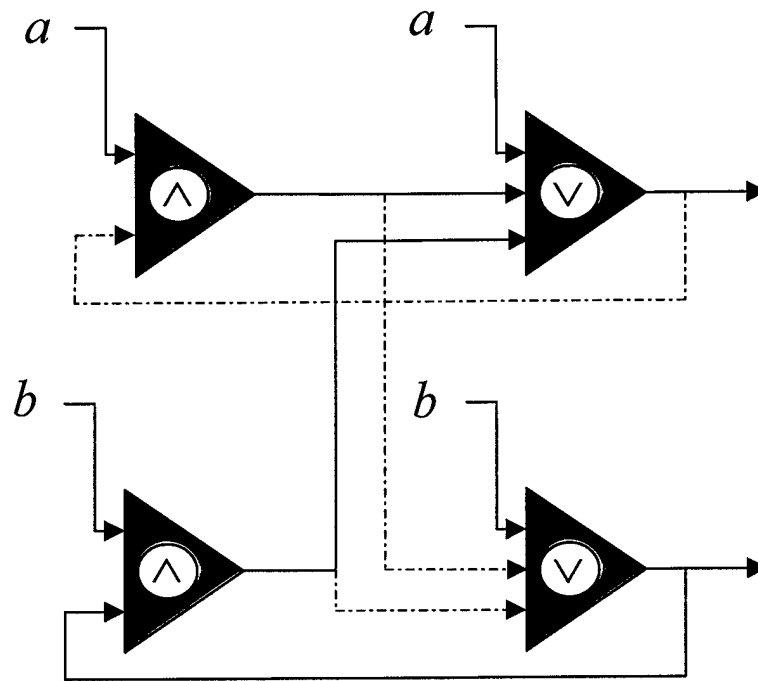

Figure 8: An Illustration of the necessary and sufficient condition for a circuit to be combinational. For  $a=0$ ,  $b=1$ , the wires drawn in red are inert.

The numerous examples we have generated demonstrate that feedback is an important concept for combinational circuits. Our analytical results permit us to establish precisely under which conditions cyclical circuits are combinational. Specific directions of further research are:

- to categorize which sets of functions can be implemented efficiently with cyclical circuits and which can not;
- to derive lower bounds on the number of gates in cyclical implementations;
- to investigate the tradeoff between delay and circuit size; in particular, it might be possible to trade increased delay for fewer gates with cyclical implementations.

The area of combinational circuit design, also referred to as logic synthesis, has been an active area of research for several decades. Sophisticated software packages have been developed for the automated design of circuits (see, for example, [4]). However, none of the research projects have considered cyclical implementations. A long-term goal of our research is to incorporate ideas and techniques for the synthesis of cyclical circuits into existing design methodologies.

- [1] W.H. Kautz, "The Necessity of Closed Circuit Loops in Minimal Combinational Circuits", IEEE Trans. Comp., Vol. C-19, pp. 162-166, 1970.
- [2] R. L. Rivest, "The Necessity of Feedback in Minimal Monotone Combinational Circuits," IEEE Trans. Comp., Vol. C-26, No. 6, pp. 606-607.
- [3] F.J. MacWilliams and N.J. Sloane, "The Theory of Error-Correcting Codes", North Holland, pp. 370-373, 1977.
- [4] R.K. Brayton, G.D. Hachtel, C.T. McMullen, and A.L. Sangiovanni-Vincentelli, "Logic Minimization Algorithms for VLSI Synthesis", Kluwer Academic Publishers, 1984.

## **Appendix B:**

# **CLASSIFICATION AND ANALYSIS OF THE REGULATORY MODULES THAT GENERATE BIPHASIC SIGNAL RESPONSE IN BIOLOGICAL SYSTEMS**

A. Levchenko, J. Bruck and P. W. Sternberg

### **ABSTRACT**

In this report we review multiple phenomena of biphasic regulation of response by the signal strength in various biological settings. This type of regulation is presented as an example of a functional module with different possible biochemical implementations. We argue that there are four general types of mechanisms generating biphasic response, each possessing unique characteristics defining its tunability by external influences. We suggest that these unique properties may define whether using a specific regulation type might be beneficial in given biological circumstances. We propose that analyses similar to the one presented here may prove of use for better definition and characterization of other functional biochemical modules.

The complexity of regulatory intermolecular interactions underlying various cellular functions is now well appreciated. Analysis of various signal transduction pathways continuously reveals a high degree of cross-talk, spatial and temporal organization and multiple connections to other, highly organized multi-molecular systems, e.g., involved in metabolic, electrophysiological and cytoskeletal regulation. Understanding the functioning of such multicomponent networks within the context of constantly changing intracellular and extracellular milieu is critical for the post-genomic investigation of biologic function. However, the sheer complexity of the underlying models can fast become daunting and precise analysis intractable. It has been suggested that some concepts and techniques borrowed from the engineering disciplines dealing with complex systems can prove useful in the study of biochemical and genetic networks (Hartwell, et al, 1999; McAdams and Arkin, 2000; Hasty et al., 2001).

It has long been accepted by the control engineers and electronic circuit designers that the performance of complex, highly interconnected systems can be difficult or impossible to analyze even if all connections are known. And yet computer chips, power lines and computer networks seem to perform well enough to satisfy our needs. The reason lies in the extensive use of computer models and hierarchical approach in their design. In designing a new electronic device one often deals with functional units, such as filters, amplifiers and integrators rather than with elementary components, such as transistors. A similar approach has been recently advocated for analysis of existing and design of novel biological regulatory systems.

The idea that biochemical circuits can sometimes be viewed as modules designed to perform certain functions has gained some support when it was demonstrated that some signaling molecules, such as CaMKII, could serve as frequency decoders (De Koninck and Schulman, 1998),

while whole signal transduction pathways, such as those in photoreceptors, have evolved to be extremely sensitive signal amplifiers (Leskov et al., 2000). Some simple biochemical modules capable of filtering out internal fluctuations, switching between two stable states and oscillating have been constructed in *E. coli* using transcriptional repressors (Hasty et al., 2001). In addition, it has been demonstrated that some design principles, such as integral feedback, can be transferred into biological analysis from control engineering (Yi et al., 2000). However, identification of functional modules has so far been rather haphazard and no classification of different functions performed by such modules in biological settings has emerged.

It can be proposed that identification of functional biological modules can be approached from either *structural* or *functional* perspectives. Structurally, one can identify a universal signaling unit, such as mitogen-activated protein kinase (MAPK) cascade, and then analyze various properties this biochemical circuit can have. The advantage of this method is that one is not biased at the outset to find certain functional characteristics and novel functions, not necessarily related to those currently used in control engineering, can be identified. Alternatively, one can take a certain predetermined *function* as a criterion and search for implementations of this function in existing biological systems. The advantage of this method is that can provide a “tool box” of various implementations, each potentially suited to a certain set of biological circumstances. In this report this function-based method of regulatory module identification is used.

Here we describe several modes, in which the same function – band-pass filtering of the amplitude of the signal – is implemented in biochemical circuits of eukaryotic cells. We will refer to this function as *biphasic regulation*. Biological systems possessing this kind of circuits are adjusted to respond to a certain optimal value of the external signal, whereas the response to signals of intensity either higher or lower than optimal is suppressed. As will be seen, in spite of the diversity of the means, by which the optimal regulation is effected in particular systems, the persistent motive is positive response regulation at low and negative regulation at high concentrations of the regulator molecule. We will also demonstrate that the “bell-shaped” response curves are not rigid and can, both in theory and often in experiment, be shifted and otherwise modified by various cofactors.

We chose biphasic regulation as a test case for defining and characterizing functional modules primarily due to the absence of a unified picture of diverse biochemical phenomena, in which this sort of regulation is observed. Indeed, biphasic regulation has been described in various settings, both on the cellular and organismic levels. However, to date no attempt has been made to investigate whether there might be some common general mechanisms underlying these responses, nor a particular need for having biphasic regulation in biology has been explored. In this review we propose a classification of biphasic responses based on different kinds of mechanisms underlying them and show that the employment of a particular regulation type may be correlated with the specific function it is used to accomplish. Although these correlations are, at this point, hypothetical, the available experimental data provide some evidence that they do exist. Pending further investigation we can claim that biphasic regulation is an example of a “smart” biochemical circuit design, in which the signal is processed by a system in a non-linear and tunable manner, with a particular choice of chemical implementation being determined by limitations of the system and characteristics of the regulated process.

Although biochemically the circuits leading to biphasic regulation can be very diverse, mechanistically they can be subdivided into four different types (Fig. 1). We will introduce and characterize each type in detail below. Here we would like just to define these types briefly and point out their properties (Table I). The first two types of biphasic regulation arise from interaction of two molecules, receptor and ligand, resulting in activation of the receptor. In the Type I regulation the biphasic dependence of the receptor activation results from the ability of the ligand to oligomerize and from the fact that only the monomeric form of the ligand is activating. The Type II regulation results from existence of two types of binding sites on the receptor molecule having different affinity for the ligand, so that binding of the ligand to the higher affinity site activates the receptor, whereas binding of the ligand to the inhibitory site inactivates the receptor. The last two biphasic regulation types arise from interaction of signaling pathways with potentially multiple molecules participating. The Type III regulation results from interaction of two pathways branching from a single point and converging to a single response element. One of the pathways, activated at lower signal input values, activates the response element, whereas the other pathway, activated at higher input values, inhibits it. Finally, in the Type IV regulation there is a biphasic dependence on the concentration of the components of one signaling pathway that can be regulated by another pathway. It is clear that the ability of external factors to tune the response in each of the regulation types is different with the Type I being the least and the Types III and IV the most tunable. The analysis of the parameters affecting the tunability of the response and multiple examples of each biphasic regulation type are given below.

In the next section, beginning by formulating a general mechanism(s) for each of the possible types of this "signal selectivity" module, we proceed to explore the unique characteristics of each type and suggest possible functional consequences of these characteristics. We then attempt to correlate the unique functionality of each module type to the specific set of biological processes, in which it is used, through a variety of examples.

## MODES OF ACHIEVING A BIPHASIC RESPONSE

In this section we will examine several distinct mechanisms by which a biphasic response to variation of concentration of a signaling molecule (also referred here to as ligand) is achieved in biological systems. We will argue that these mechanisms can be classified into four different modes of action, according to the composition of the underlying biochemical circuits.

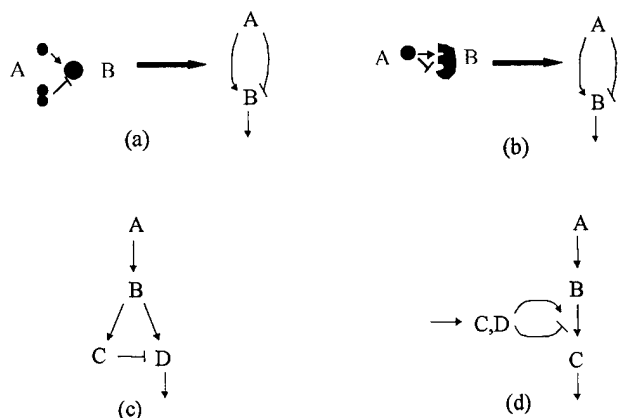

Figure 1.

Types of biological biphasic regulation. In the Type I regulation (a) biphasic dependence of activation of B is due to dimerization of its ligand A; in the Type II regulation (b) biphasic activation of B results from existence of a high affinity activating and low affinity inhibitory binding sites in B; in the Type III regulation (c) biphasic output is due to existence of an activating and inhibitory signaling pathways activated by the same signal A and leading to the same response element D; in the Type IV regulation (d) the output depends biphasically on the activation of a secondary signaling pathway that changes the concentration of molecules that can be parts of the primary pathway (such as C) or accessory proteins (such as D), e.g., scaffolds. Note that though schematically Type I and II responses are equivalent, the underlying mechanisms are quite distinct (see text for more details).

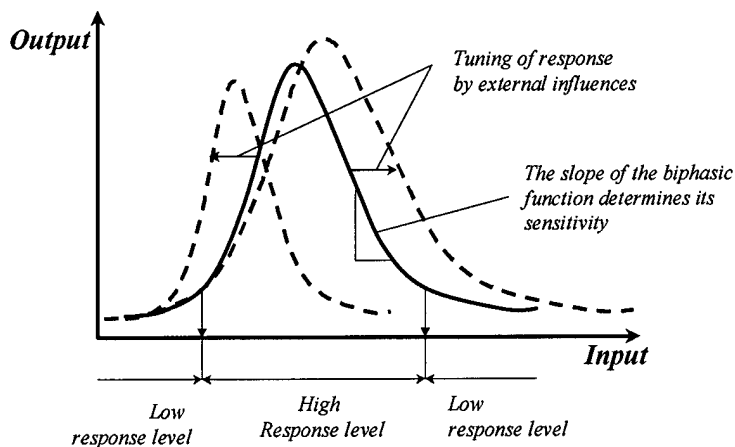

Figure 2.

The general form of a biphasic input-output relationship is similar to the response characteristics of a band-pass signal amplitude filter (Fig. 2). The system responds maximally within a relatively narrow range of the input values with the output decreasing away from this range, as the input becomes too low or too high. This dependence allows the system to selectively respond to the signal strength that may be optimal for some downstream process. A biphasic dependence can be tuned to various input values by shifting the maximum of the dependence and/or changing its amplitude. This can be achieved through variation of externally regulated parameters. The number of such control parameters defining tunability of a biphasic system is different for each of the four regulation types. A biphasic regulation is also characterized by its *sensitivity* to variation of the input values, defined here as the (maximum) slope of the biphasic dependence curve. Sensitivity can also be determined by the value of the control parameters.

#### *Type I regulation*

The simplest way of achieving a biphasic response is through the possibility that, depending on the concentration, the ligand itself can exist in either activating or inhibitory form. Indeed, this mode of regulation is realized in a variety of biochemical systems by ligand oligomerization. If both

monomeric and oligomeric ligand forms can bind to a single site on a receptor molecule with only the monomeric form being able to activate the receptor, the activation will depend on the ligand concentration biphasically. The oligomeric form of the ligand may but does not have to actively repress the receptor activation to achieve this response. We will classify this mode of biphasic response as *Type I* (Fig. 1A).

One can now try to formulate some general properties of this ligand oligomerization-dependent response. The first obvious property is that it can only occur if the ligand is capable of oligomerization. As we shall see below, the other classes of biochemical modules leading to biphasic regulation do not impose this requirement. The second property of this regulation type is that a single binding site for both ligand monomers and oligomers is presumed to exist. This property implies that binding of monomeric and oligomeric ligand species is competitive. The exact character of the competition is determined by the affinity of the ligand to the binding site. This affinity can vary from one receptor to another or be modified for a given receptor by various co-regulatory components. Thus the receptor-ligand affinity is the only receptor related parameter that can be regulated, if the response of a given receptor is to be tuned to be maximal at a certain ligand concentration.

The second parameter that may affect the amplitude and the position of the maximum of the response is the affinity of the monomer-monomer interaction in the oligomerization reaction. In principle, this affinity can be changed by some ligand modification, e.g., phosphorylation. It is important to note that this parameter is ligand- but not receptor-dependent, so that its variation affects the responses of all potential receptors exposed to the ligand. In this sense, the affinity of ligand oligomerization is a *global* parameter, while the affinity between ligand and receptor is a *local* parameter that can be varied just for a given receptor.

A generic monomer-activated/oligomer-inhibited system described above can be simulated using a simple modeling approach. As expected, a variation of the affinities of monomer-monomer and ligand-receptor interactions is predicted to result in changes of both the amplitude and the position of the maximum of the response. In particular, an increase in the affinity of oligomerization decreases the amplitude and negatively shifts the position of the maximum, whereas an increase in the affinity of ligand binding leads to an increase in the amplitude and a negative shift in the position of the maximum.

Another factor that is affected by changes in the affinities of molecular interactions is the sensitivity (defined as the slope of the functional dependence, Fig. 2) of response to variation of the ligand concentration. The sensitivity increases with an increase of the affinity of ligand-receptor interaction. It also increases when active response suppression by oligomers or successively higher degrees of oligomerization is considered. Thus a high sensitivity of response can only be achieved at relatively low ligand concentration.

Examples of Type I regulation are encountered mainly in the regulation of gene transcription by various transcription factors. One of the better characterized is the regulation by *Krüppel* (Kr), a *Drosophila* zinc finger-type transcription factor that forms a bell-shape concentration gradient in a central position of the blastoderm. *In vitro* and, recently, *in vivo* it has been demonstrated that Kr can both activate and repress gene expression through interaction with a single DNA-binding site (Sauer and Jackle, 1993; La Rosee-Borggreve et al., 1999). These opposite regulatory effects of Kr

are concentration-dependent, and they require the N-terminal region of Kr for activation and the C-terminal region for repression. It has been suggested that at low concentrations Kr exists mainly in monomeric form and activates gene expression (e.g., a pair-rule gene *hairy*), while at high concentration Kr dimerizes and in this dimeric form can only inhibit transcription. It is interesting that the expression of Kr itself, as well as other early developmental regulators *engrailed* and *caudal* can be autonomously regulated in a biphasic fashion by another transcription factor *hunchback* (Hb) (Schulz and Tautz, 1994; Schulz and Tautz, 1995). Again, this regulation is achieved by transcriptional activation at low and repression at high Hb concentrations. While it is likely that the exact mechanism involves differential regulation by Hb monomers and dimers, further study of this mechanism is needed.

Biphasic regulation of the Type I is also observed in transcriptional control of many genes expressed in erythroid and megakaryocytic cells by a small transcription factor Maf (Motohashi et al., 2000). At low concentrations Maf affects transcription positively by heterodimerizing with another class of factors – Cap-n-Collar (CNC). At high Maf concentrations, excessive homodimerization interferes with interaction of Maf with its response element thus downregulating transcription, which may lead to lethal anemia in transgenic mouse embryos.

Another important example of the Type I regulation is the mechanism of function of a tumor suppressor p53. It is not entirely clear how a particular steady state concentration of p53 is maintained in the absence of DNA damage. It has been suggested that p53 homeostasis can be largely due to p53 inhibitor MDM2, inducible by p53 (Wu et al., 1993). MDM2 and p53 thus form a negative feedback loop that can prevent unregulated increases in p53 expression. Another line of evidence suggests that p53 autoregulation can be due to the mechanism of transactivation of p53 targets including itself. Indeed, it has been proposed that this transactivation occurs in a concentration-dependent biphasic manner (Kristjuhan and Maimets, 1995). Moreover, tetramerization of p53 at high concentrations seems to mediate inhibition of the transactivation (Kristjuhan et al., 1998). Since action of MDM2 requires that p53 be oligomerized (Maki, 1999), one can suggest that p53 concentration is maintained close to the tetramerization threshold. A recent finding that p53 can positively regulate its own transcription (Benoit et al., 2000) reinforces the view that p53 is autoregulated in part due to a combination of biphasic response and positive feedback (Levchenko et al, 2001).

### *Type II regulation*

A second mode of achieving biphasic regulation in direct ligand-receptor interaction can be realized if the receptor has two types of binding sites: high affinity activating and low affinity inhibitory sites. We will term this mode *Type II* biphasic regulation (Fig. 1A, Box 1). This type of regulation, unlike Type I, does not require ligand oligomerization. Thus this type is less restrictive and can provide the possibility of biphasic regulation by essentially monomeric ligands, such as ions. Another property of Type II regulation distinguishing it from that of Type I is the non-competitive character of ligand binding to the activating and inhibitory sites. The ligand affinities to these sites can be different and vary from one receptor to another. As a consequence, there are two receptor related parameters, modification of which can affect the amplitude and the position of the maximum response for a given receptor. Therefore both these parameters are local. By contrast, one local and one global parameters were identified in Type I regulation.

A more detailed analysis shows that increasing the affinity to the activating site results in higher magnitude responses with the maximum position shifting to lower ligand values. There is a concomitant increase in the sensitivity of response to variation of the ligand concentration. Decreasing the ligand affinity to the inhibitory site results in an increased amplitude of response with the maximum position shifting toward higher ligand concentrations. The sensitivity of response concomitantly decreases. As in the Type I regulation high sensitivity generally may be achieved only at relatively low ligand concentration values. We can conclude that variation of the two affinity parameters may locally adjust both amplitude and the position of maximum in any direction for a given receptor species. This property is in sharp contrast to the Type I regulation, in which an increase in amplitude of the response is always accompanied by a negative maximum shift in the biphasic response curve.

A well-known example of a system exhibiting Type II regulation is encountered in  $\text{Ca}^{2+}$  homeostasis.  $\text{Ca}^{2+}$ -activated  $\text{Ca}^{2+}$  release, shown to be important in a multitude of intracellular processes, is mediated by  $\text{IP}_3$  and RyR sensitive  $\text{Ca}^{2+}$  channels in the endoplasmic reticulum. Of these the  $\text{IP}_3$ -sensitive channel, known as  $\text{IP}_3$  receptor ( $\text{IP}_3\text{R}$ ), has been studied to a larger extent (Keizer et al., 1995; Li et al., 1995). We thus restrict ourselves here to the discussion of  $\text{IP}_3\text{R}$ . The opening probability of  $\text{IP}_3\text{R}$  is a biphasic function of cytosolic  $\text{Ca}^{2+}$  concentration, arising from activation of the channel at low and inactivation at high  $\text{Ca}^{2+}$  concentrations (Iino and Tsukioka, 1994). It has been demonstrated that this biphasic regulation stems from the presence of a high affinity activating and low affinity inhibitory  $\text{Ca}^{2+}$  binding sites on each of the four receptor monomers. This opening probability dependence can be dramatically altered, both in terms of the position and absolute value of its optimum by varying  $\text{IP}_3$  concentration (hence the name of the channel) (Mak et al., 1998) and ATP (Mak et al., 1999). Thus, increasing  $\text{IP}_3$  concentration leads to a positive shift in the position of the optimum and an increase in the maximum opening probability. This effect of  $\text{IP}_3$  has been attributed to its ability to decrease allosterically the affinity of  $\text{Ca}^{2+}$  to the inhibitory site, while the affinity to the activating site remains constant. An increase in ATP concentration shifts the position of the optimum negatively by decreasing the  $\text{Ca}^{2+}$  affinity to the activating site. An important property of  $\text{IP}_3\text{R}$  is the inherent feedback of the output (probability of  $\text{IP}_3\text{R}$  opening) to the input ( $\text{Ca}^{2+}$  concentration). The consequences of this feedback regulation are discussed below.

Calcium has also been demonstrated to have a biphasic effect on activation of various adenylyl cyclases (Guillou et al., 1999). As in the case of  $\text{IP}_3\text{R}$ , this biphasic regulation apparently results from existence of a high ( $\sim 0.2 \mu\text{M}$ ) and low ( $\sim 0.1 \text{mM}$ ) affinity  $\text{Ca}^{2+}$  binding sites. Binding of  $\text{Ca}^{2+}$  (in complex with calmodulin) to the high affinity site activates the cyclases, while  $\text{Ca}^{2+}$  association with the low affinity site inhibits them by competing with another activating agent  $\text{Mg}^{2+}$ .

Another class of Type II responses is encountered in transcription regulation. TATA binding protein (TBP) binds to TATA boxes, elements commonly found in the promoters of various highly expressed eukaryotic genes at approximately 25-35 base pairs upstream of the start site. TBP, when bound, provides (with some additional factors) nucleation sites for the assembly of general transcription machinery. The central role of TBP in transcription initiation suggests that its expression is tightly regulated. Investigation of the regulatory elements in TBP promoter reveals presence of a TATA box required for basal transcription and two control elements that bind another

transcription factor: TBP promoter-binding factor (TPBF) (Huang and Bateman, 1997). One of the control elements, a higher affinity binding site located upstream of the TATA box, is activating and the other one, a lower affinity binding site located between the TATA box and the start element, is inhibitory for transcription activation. The action of TPBF on the second site is negative presumably because it interferes with binding of TBP itself to the TATA box. Exposure of the TBP promoter to various amounts of TPBF results in a biphasic curve with the maximum at approximately 50 nM.

A similar regulation strategy is used in autoregulation of *fnrN* genes from *Rhizobium leguminosarum* used to control nitrogen fixation and hydrogenase activity (Colombo MV, Gutierrez D, 2000). The promoters of *fnrN* contain two *fnrN* binding sites, with affinities to *fnrN* differing five-fold. The higher affinity site is activating and the lower affinity site is inhibitory for *fnrN* transcription resulting in biphasic dependence of the rate of *fnrN* expression on *fnrN* concentration.

As discussed below, a member of Wnt family, Wingless (Wg) may regulate its targets in a biphasic manner. It turns out that Wg signaling itself can be biphasically regulated by another protein, sFRP-1 (Uren et al., 2000). It has been demonstrated that increasing sFRP-1 concentration results in activation of Wg signaling at low and inhibition of Wg signaling at high sFRP-1 concentration. The postulated mechanism of this optimal regulation again involves existence of a high affinity inhibitory and low affinity activating binding sites for sFRP-1 on Wg.

### *Type III regulation*

The Type I and Type II regulation can be achieved with only two interacting molecular species. The signal, in the form of a ligand impinges directly on the response element (receptor). In many instances, however, the signaling molecule can be removed from the response element (RE) by signal transduction pathways. Properties of these pathways may influence the response characteristics. We will now consider biphasic responses that can be achieved due to interaction of signaling pathways stimulated by the same input signal. The recurring motive here is that at low input values only activating pathway is stimulated, while the high input values result in stimulation of both activating and inhibitory pathways, with the overall effect being the inhibition of the output. We term this mode of biphasic regulation the *Type III* regulation (Fig. 1B). We note that RE may not be the final target of signaling, but rather the point, at which signal integration takes place.

Investigation of mechanisms underlying the Type III biphasic regulation is not as straightforward as that of the Type I and Type II, because, in principle, interacting signaling pathways can be arbitrarily complex. However, we can still make some inferences about the properties of the Type III regulation based on the following considerations.

We note from above that, unlike in Type I and Type II, the biphasic character of response is now a consequence of the properties of signal transducing components rather than just the properties of RE. However, the nature of RE can allow modifications of the biphasic response leading to possibility of adjusting the response to certain values of the input. We can assume that the molecular inputs from the signal transducing components onto RE can interact with RE by competitive or non-competitive binding, or by inducing the transition of RE into an activated or

inactivated state enzymatically. Consideration of these different possibilities leads to the following results.

If the signal transducing molecules bind to RE competitively biphasic response can only occur at sufficiently low levels of the input, whereas at high levels the influence of the inhibitory molecule becomes insignificant as the dependence of both signaling molecules on the input saturates. In addition, simple analysis reveals that in order to obtain a local maximum in the response curve, the inhibitory signaling pathway has to result in a non-linear (with the power higher than unity) dependency on the input signal. Such non-linearity can be introduced, for instance, by amplification in the signal pathway or by binding of oligomers of signaling molecules to RE. Further analysis shows that increasing affinity of the inhibitory signaling molecule toward RE leads to shifting of the maxima and amplitudes of the response toward lower values with a concomitant increase in sensitivity of the response. An increase in the relative strength of the inhibitory signal leads to similar results. Finally, increasing the affinity of the activating molecule toward RE leads to shifting of the maximum of the response toward lower values with concomitant increase in the amplitude. These properties are analogous to those seen in Type I response. We can thus conclude that both the properties of RE and of signal transducing parts of the pathways may affect selectivity of the response to the input values.

There is a similar connection between the case of non-competitive interaction of the inhibitory and activating molecules with RE and Type II responses. Here the induction of biphasic responses is much more robust and resemblance to the Type II regulation more explicit. An increase in either the strength of the activating signal or the affinity of the activating molecule to RE leads to a shift of the maximum of the response to lower values and an increase the amplitude and sensitivity of response. By contrast, an increase in the strength of the inhibitory pathway or the affinity of the inhibitory molecule to RE shifts the maximum of response to higher values, and increases the amplitude but decreases the sensitivity of response. An important difference between this subclass of Type III responses and Type II responses is that there are no longer any specific requirements on the affinities of the activating and inhibitory binding sites to the corresponding ligands.

Finally, we consider the mechanism of achieving biphasic response by activating and/or inhibitory pathways acting on RE enzymatically. This mechanism is not in any way analogous to the Type I or Type II responses. The essential new requirement for this mechanism is that RE has to be chemically modifiable, with the output associated with one of the modified states. Analysis of this sort of interactions reveals that increases in the relative input values leading to initiation of the inhibitory response increase the amplitude of the response, with the maxima shifting toward higher values and sensitivity decreasing. Decreasing the strength of the inhibitory signal leads to similar results. Significantly, in contrast to mechanisms considered previously, there is no parameter defining the system, variation of which would shift the maxima of response toward lower values with a concomitant *increase* in the amplitude.

Probably the best-characterized example of the Type III regulation is encountered in the mesoderm induction in the early gastrula of *Xenopus laevis*. Various signals produced in the vegetal hemisphere of the embryo act on adjacent equatorial cells. One of these signals is mediated by a TGF $\beta$  homologue, activin, capable of affecting transcription of several genes, most notably Xbra and goosecoid (McDowell et al., 1997). It has been demonstrated in a number of studies that the effect of activin signaling is concentration dependent, so that Xbra is induced in a relatively narrow

window of intermediate activin concentrations. Increasing or decreasing activin concentrations from this optimal level leads to inhibition of Xbra expression (Dyson and Gurdon, 1998). The signal transduction properties of this pathway have been elucidated in detail.

As in other TGF- $\beta$  pathways, the activated receptor initiates signaling by phosphorylating a signal transducer of SMAD family, SMAD2, which then becomes associated with the cofactor SMAD4 and is translocated to the nucleus in a heteromeric complex. In the nucleus, the SMAD2/SMAD4 complex is thought to directly activate gene transcription through cooperative interactions with DNA and other DNA-binding proteins (Watanabe and Whitman, 1999). The properties of this pathway have been studied quantitatively, so that it is known that around 100 and 300 of activin molecules have to bind the receptor to activate the Xbra and goosecoid expression respectively (Dyson and Gurdon, 1998). In addition, approximately  $3.3 \cdot 10^5$  and  $10^5$  molecules of SMAD2 can reconstitute the activation of respectively Xbra and goosecoid in the absence of the activin stimulation (Shimizu and Gurdon, 1999). Since the ratios of signaling molecules needed to activate Xbra and goosecoid are 3 in both cases, these data have indicated that the signaling input is linearly translated into the output. Importantly, the expression of Xbra is suppressed by high goosecoid concentrations.

From the experimental data reviewed above we can reconstitute the following simple picture of the optimal activation of Xbra by activin. When activin is present at concentration sufficient to activate around 100 receptors, Xbra expression is positively regulated. However, if the activin concentration is increased about three-fold, goosecoid expression is induced, affecting the expression of Xbra negatively. Other signaling pathways, most notably the FGF pathway, can also modulate the expression of Xbra. Thus, depending on the combination of signals at a particular cell location, the optimal response in Xbra expression may change.

We now turn back to *Drosophila* development to consider a signaling pathway mediated by a member of Wnt family, Wingless (Wg) (Dierick and Bejsovec, 1999). Wg signaling affects a number of developmental events including formation of the embryonic midgut. It has been observed that in the midgut Wg acts to regulate expression of two proteins: Ultrabithorax (Ubx) and labial (lab) in an optimal fashion (Yu et al., 1998; Hoppler and Bienz, 1995). In regulation of Ubx, the Wg pathway interacts with another signaling pathway activated by a TGF- $\beta$  homologue Decapentaplegic (Dpp). Dpp signals through SMAD proteins in a manner similar to signaling by activin, as discussed above. From a careful experimental study the following picture of Ubx regulation by Wg emerged (ref.). At low Wg concentrations Wg signaling can directly stimulate Ubx transcription acting in cooperation with Dpp activated Mad protein. As Wg concentration is increased, Wg signaling activates another putative SMAD protein WR that, when further activated by Dpp, competes with Mad for DNA binding, and, thus, inhibits Ubx transcription. The resulting optimal regulation curve can be modified by action of other signaling molecules. For example, a homeotic transcription factor Abdominal-A (Abd-A) apparently can directly suppress Ubx expression (Yu et al., 1998).

Another example of interaction of signaling pathways leading to optimal regulation is the bell-shaped kinetics of cAMP accumulation in brown adipocytes in response to norepinephrine (NE) (Bronnikov et al., 1999). A detailed analysis revealed that the adenylyl cyclase mediated production of cAMP was upregulated at low NE concentrations through G-protein signaling, as is

expected in  $\beta$ -adrenergic response. However, higher NE concentrations led to increasing cytosolic  $\text{Ca}^{2+}$  concentration, which stimulated a calmodulin-controlled phosphodiesterase, possibly PDE-1. Activation of the phosphodiesterase, in turn suppressed the adenylyl cyclase leading to low cAMP production.

#### *Type IV regulation*

In all the types of biphasic regulation analyzed above only a single input was required to elicit a biphasic response. Other inputs have been implicitly assumed to be able to change the parameters defining the system and to tune the response by affecting its amplitude, the position of the maximum and the sensitivity to the input variations. The next type of mechanisms generating biphasic response requires two inputs to be present, with the system responding biphasically to one of them. Often the input to which the system responds biphasically is related to the concentrations of the components of the system, while the other input is required for initiation of the system's activation. For example, both reduced expression and overexpression of a member of a signaling pathway may lead to inhibition of signaling. This class of biphasic regulation mechanisms, referred to as *Type IV* (Fig. 1C), is much loosely defined compared to Types I-III, since it can be mediated by a variety of mechanisms. An interesting aspect of Type IV regulation is that it may help redefine the nature of the primary input into a signal transduction system. Below we analyze two mechanisms leading to Type IV response.

The first mechanism, by which Type IV biphasic response can be achieved, is usually referred to as the pro-zone effect or, more recently, combinatorial inhibition (Levchenko et al., 2000). Combinatorial inhibition results from the presence of a cross-linking agent capable of binding two or more interacting molecules (ligands) into a single functional complex. Examples of such cross-linking agents include scaffold and adapter proteins implicated in various signal transduction pathways. Theoretical and experimental analysis of combinatorial inhibition reveals that there is a biphasic dependence of the output, assessed as the concentration of a three-member cross-linker-ligand complexes ("two-slot" cross-linker is considered for simplicity). This dependence arises from the fact that high abundance of cross-linker leads to high probability that only a single binding site is occupied, the effect precluding formation of a three-member complexes. Low abundance, of course, will also lead to non-functional complexes due to low number of available binding sites. The important question of the location of the maximum of the response has been addressed by us previously (Levchenko et al., 2000), with the main result, being that this position is dependent mainly on the concentrations of the ligand molecules rather than their affinities for the corresponding binding sites. It can be shown that, for all affinity values producing high functional complex concentrations, the position of the maximum is always located between the values of the concentration of the two ligands. If the difference between the concentrations of the ligands 1 and 2 is great, the biphasic dependence can lose its sensitivity to the cross-linker concentration and "spread over" the range defined by the concentrations. It is also easily shown that the amplitude of the dependence is always limited by the lower of the ligand concentrations. Thus the ligand concentrations determine both the position of the maximum and the amplitude of response. In a sense, therefore, the system is "chemistry insensitive" with concentrations of the components rather than binding constants playing the primary regulatory role.

The second mechanism of Type IV regulation arises from non-processive molecular activation. Non-processive activation means that, first, two or more interactions between an activator and activated molecules are necessary for full activation and, second, these activation reactions are separated by full dissociation of reacting molecules. This sort of molecular interaction produces biphasic dependence on the concentration of the activated molecule, provided that a reverse, inactivating reaction also takes place. A more detailed analysis shows that the primary reason for a decrease in response is the saturation of the activator molecule at high concentrations of the substrate. The secondary activation events become rare as the molecules in the intermediate activation stage are deactivated in reverse reactions. Variation of multiple parameters of the system, such as the binding and reaction constants and concentration of the activator molecule leads, in a straightforward manner to changes in the amplitude of the response. The changes in the position of the maximum are invariably positively correlated with the changes in the amplitude. The high sensitivity response, in which high amplitude is combined with relatively low position of the maximum, is thus not possible.

A MAP kinase (MAPK) cascade consists of three sequentially acting kinases (Garrington and Johnson, 1999). The last member of the cascade, MAPK, is activated by dual phosphorylation at tyrosine and threonine residues by the second member of the cascade: MAPKK. MAPKK is activated by phosphorylation at threonine and serine by the first member of the cascade: MAPKKK. The dual phosphorylation reactions occur in solution in a distributive manner, that is the two phosphorylation reactions are separated by full dissociation of kinase and its substrate. It has been shown theoretically and experimentally that the distributive character of MAPKK and MAPK activation leads to a biphasic dependence of the signaling output on the concentrations of these kinases (Burack and Sturgill, 1997; Kieran et al., 1999; Sugiura et al., 1999). In simple terms, this dependence results from saturation of the activating kinases (MAPKKK or MAPKK) by unphosphorylated substrates (MAPKK or MAPK, respectively) at high substrate concentrations, making second substrate phosphorylation unlikely. In some systems MAPKK and MAPK expression can be up-regulated as a result of signaling in this pathway, thus creating a feedback on the level of the concentrations of the signaling components. Below we discuss potential consequences of this feedback.

The next example of optimal regulation by concentrations of signaling components is found in regulation of signaling by scaffold proteins. Both theoretical analysis and experimental observations indicate that dependence of MAPK cascade activation in the scaffold concentration is biphasic. This dependence has been observed for at least one scaffold protein KSR-1 (Cacace et al., 1999). The mechanism of this optimal regulation is similar to the combinatorial inhibition effect, predicted for any molecular cross-linker. At low scaffold concentrations formation of the functional kinase-scaffold complexes is limited by the concentration of the scaffold, while at high scaffold concentrations most scaffold molecules are predicted to be empty or connected to just one kinase molecule. Hence overabundance of scaffold molecules inhibits formation of functional complexes.

The classification of the biphasic responses into four different types is summarized in Table I. In the next section we consider whether the unique properties of each regulation type might be correlated with the use of a certain type for a desired biological function.

Table I. Summary of biphasic regulation types.

Type of regulation	Parameters affecting tunability of the response	Potential biological function	Examples
I. Negative regulation by monomers and positive regulation by oligomers	1 local, 1 global	Global "topology" preserving regulation of multiple targets on the level of the response element	Transcription regulation by Kr and Hb in <i>Drosophila</i> segmentation; Transcription regulation by Maf and p53
II. Negative regulation by binding to a low affinity site and positive regulation by binding a high affinity site	2 local	"Pinpoint" local regulation on the level of the response element	Opening of IP <sub>3</sub> channels by Ca <sup>2+</sup> ; Activation of adenylyl cyclases by Ca <sup>2+</sup> ; Activation of TBP promoter by TBFP; Activation of Wingless signaling by sFRP-1 in <i>Drosophila</i> ; Transcription regulation by fnrN in <i>Rhizobium leguminosarum</i>
III. Negative regulation by activating one		Possibility for global	Induction of <i>Xbra</i> by activin; Induction of <i>Ubx</i> by

---

branch of a pathway, positive regulation by activating the second branch of the pathway

Multiple global

regulation not affecting the response element

Wingless;  
Activation of cAMP production by norepinephrine;

IV. Biphasic regulation arising from variation of the concentration of a member of the pathway

Multiple global

Tuning response to activation of a second pathway. Preventing "cross-talk" activation.

Regulation of the output of MAPK cascade by variation of the concentrations of MAPKK, MAPK and scaffolds (e.g., KSR-1)

---

## WHY ARE THERE DIFFERENT BIPHASIC REGULATION TYPES?

From the previous sections it is not immediately clear if employing a certain mechanism can provide some benefits for a particular function or is purely incidental. For instance, we have seen that the biphasic response mechanisms defining Types I-III regulation are all directly implicated in developmental processes, and that the mechanisms of Types I and II can both directly regulate transcription. Some insights into the functional specificity of each mechanism can be gained by analyzing the possible reasons for using biphasic response in a particular biological setting in light of the unique properties exhibited by each regulation Type.

One of the most important advantages that a biphasic response can provide is tunable filtering of the magnitude of the incoming signal (Fig. 2). This filtering is akin to the band-pass filtering widely used in electrical engineering with the important difference that here the signal amplitude rather than frequency is filtered. What it means biologically is that a response element can only be activated within a certain range of the signal strength. This range can be determined by the inherent characteristics of the responding system as well as through the influence of additional modifiers. Above we saw that each biphasic regulation type was characterized by a set of parameters that could determine the position of the maximum, the sensitivity and the strength of response. Variation of these parameters can tune the system to respond optimally to some input value. The number of the parameters determines the flexibility or "tunability" of the system. Another important characteristic is whether the parameters affect the system "globally", by changing the response of multiple potential targets, or "locally", by changing the response of a single target only. In what follows we attempt to see if the number and nature of parameters determining each regulation type can be tentatively correlated with the biological function.

The first group of examples of Type I regulation given above was borrowed from the transcriptional regulation of segmentation in *Drosophila* development. Segmentation is established as a series of stripes of expression of regulatory proteins along the embryo body axis. As described above, it has been demonstrated that Kr exerts biphasic regulation on *hairy* expression and, thus, may induce stripes formation due to the maximal expression at an intermediate Kr concentration. In fact, since Kr itself is distributed according to a bell-shaped curve at the center of the embryo, at least two hairy stripes can be expected to form in a symmetrical manner at intermediate Kr concentrations. The hairy stripes indeed seem to be distributed symmetrically in the Kr gradient, but there are seven of them rather than two (Carroll, 1990). In the preceding analysis we saw that the location of the maximum in the Type I response can be determined locally for each response element by the affinity of the ligand-receptor interaction. Since *hairy* has several response elements each determining its expression in a separate stripe, a mechanism for seven stripes formation can arise simply from differential affinity to Kr in each of the stripe response elements. Differences in the affinity have indeed been observed experimentally in the right order. For instance, the affinity of Kr to its binding sites in the stripe 5 element is lower than its affinity to the binding sites in the stripe 6 elements (Langeland et al., 1994). In reality, of course, *hairy* expression is regulated by a multitude of additional transcription factors that may affect the transcription as pure activators or inhibitors or in a biphasic manner similar to Kr. Nevertheless, regulation by Kr, however imprecise it may be, provides an added robustness to positioning of the stripes.

What then is a potential advantage of having the Type I regulation mechanism for segmentation? As indicated above, an important feature of this mechanism is the existence of a single global

parameter regulating the amplitude and position of the maxima of response that can be varied for all response elements simultaneously. In terms of our model, the system consisting of several responding genes or response elements can be very sensitive to changes of this parameter, namely the affinity of oligomerization of the transcription factor. With variation of this regulatory parameter, both the spatial positions and amplitudes of responses can change in a dramatic way, but, importantly, the *relative positions* of maxima remain the same. Thus the order of the *hairy stripes* would remain unchanged even if Kr dimerization was affected in some way by external factors. Therefore Type I response can provide an opportunity for global regulation preserving the “topology” of response. This global character of regulation may also be important for understanding how p53 can coordinately affect expression of multiple genes including its own in response to DNA damage or other cell stresses.

Unlike the Type I regulation, the Type II biphasic regulation is essentially local. That is a variation of parameters affecting the amplitude and the position of the maximum of response can only be done for individual response elements. In many cases, this requirement may not be very restrictive, especially if a ligand binds to a unique response element, e.g., TPBF binding to the TBP promoter. In other cases, the local character of the regulation may allow a pinpoint activation of a specific target. For example,  $Ca^{2+}$  has an exceedingly large number of potential targets in the cell. Therefore, adjusting the maximum of the response of a specific target, such as IP<sub>3</sub>R may help prevent activation of other  $Ca^{2+}$  targets, such as adenylyl cyclases, whose activity would lead to unnecessary signaling cross-talk. Indeed, as described in the literature, the optimal  $Ca^{2+}$  concentration for IP<sub>3</sub>R activation is 0.3  $\mu$ M (Taylor and Marshall, 1992), significantly different from, say, the optimal  $Ca^{2+}$  concentration for an adenylyl cyclase (AC1) activation reported to be in 1-10  $\mu$ M range (Guillou et al., 1999).

In contrast to the first two Types of response, the Types III and IV responses are regulated on the level of signal transduction rather than the level of the response element. It means that tuning of response can be achieved through adjusting the efficiency of signal propagation rather than properties of the response element activation. Tuning in these regulation types can occur through what is commonly termed signaling “cross-talk”. Depending on the circumstances, a cross-talk between different signaling pathways can be beneficial or detrimental for control of intracellular processes. It is of interest then to examine how Types III and IV biphasic regulation can help coordinate intracellular signaling by selective up-regulation or down-regulation of responses. In the following analysis we assume the presence and interaction of two signaling pathways, one of which (termed primary) propagates the signal of interest, while the other (termed secondary) adjusts the strength of this signal propagation.

In the Type III regulation the secondary pathway can shift the maximum of response of the primary pathway without affecting the overall biphasic character of this response. Therefore, if multiple cells in a tissue are exposed to a gradient of a signal, the action of the secondary pathway can be mainly to regulate the spatial position of the activation peak within the tissue. As the activity of the secondary pathway can be regulated by independent (e.g., developmental) events, two signals can collaborate in the positioning of the activity peak. Within individual cells exposed to a particular value of the signal activating the primary pathway, signaling through the secondary pathway will always lead either to a decrease or to an increase in the response amplitude. Thus the cross-talk

from the secondary to the primary pathway can be defined in a straightforward way as either positive or negative.

In the Type IV regulation the secondary pathway defines the biphasic character of response, while the primary pathway regulates its value and the position of the maximum. Thus, in a sense, the cross-talk is qualitatively opposite to that of Type III regulation. Hence, the response can be optimized to a particular secondary pathway activation level. Although, in principle, this regulation can be used for generating bands of response to morphogen gradients activating the secondary pathway, no examples of this potential gradient sensing mechanism have so far been reported. For a given level of the primary pathway activity, the secondary pathway can determine the output. The influence of the secondary pathway on the signal amplitude can be biphasic and the cross-talk can thus be said to be both positive and negative, depending on the degree of the secondary pathway activation. For instance, MAPK cascade activation may vary biphasically if the concentration of a scaffold or MAPK is changed. An inquiry into how the concentrations of the scaffold or MAPK can change reveals that there can be an additional signal affecting global or local levels of these molecules. For example, many scaffold molecules can translocate to specific portions of the cell membrane in response to a signal (Pryciak and Huntress, 1998; Bell et al., 1999). One may suggest, therefore, that it is the changes in the scaffold or MAPK concentrations rather than the input causing signaling through the cascade that a system may be tuned for.

In general, the use of the Types III and IV of biphasic regulation can be beneficial if the response needs to be tuned at the level of signal transduction rather than the level of a response element. Tuning of responses is then due to a signaling cross-talk, in which there are at least two interacting pathways, with one establishing a biphasic dependence on an external signal and the other modifying this dependence. Both these regulation types can cause global response of a variety of targets of a signaling pathway.

In the Type III response regulation involves branching into and then converging of two transducing pathways and thus adds to the simple Type I or II schemes some intermediate steps. Since each of the steps can be independently regulated, the output can be tuned at multiple points without changing the properties of the response element.

We suggest that each type of biphasic regulation can provide some unique advantages and thus be preferred for a given biological function. We should emphasize that, although there might be a strong preference for using a certain regulation type based on its properties, other, conflicting constraints may not allow it. For example, as mentioned before, the Type I responses crucially depend on the ability of a ligand to oligomerize, a requirement that not all the regulatory molecules satisfy.

## CONCLUDING REMARKS

Recently, several proposals for a wider use of engineering tools and concepts in biological sciences have been made. A new science of Systems Biology is emerging as a bridge that may allow developing the needed biological engineering understanding of complex biochemical systems. As these novel approaches take root, it is important to develop a new language, understood by both biologists and engineers, which can be used for a more accurate formalism in mathematical modeling. Classification of biological regulatory mechanisms may serve as a stepping-stone for creating this language. The categorization of the biphasic responses into four basic types presented here may be put forward as a basis for further refinement of both the classification and terminology. We propose that similar classifications can be suggested for other classes of regulatory phenomena that can be defined as functional modules following the strategy proposed here.

The usefulness of the concept of functional module can be best illustrated by employing this concept to link seemingly unrelated processes through demonstration of similar underlying design principles and functional properties. Biphasic regulation can arise in various structurally unrelated biochemical systems. We show in this review that, although the corresponding biochemistry is exceedingly diverse, it is possible to group biphasic regulation phenomena into a few classes of mechanisms each characterized by a specific set of properties. This grouping can both assist our understanding of the design and function of biochemical circuits and aid in future attempts to use these circuits in engineering novel biochemical systems.

We increasingly view the biological regulatory systems as extremely complex and capable of adaptation. The adaptability in biphasic regulation is mediated by changes in the input values leading to the maximal response. Depending on the regulation type, the response maxima can be shifted toward higher or lower input values with or without the loss in the magnitude or sensitivity. It may be suggested that some of the responses can become optimized to particular, externally constrained input values either in evolutionary process or through some sort of feedback. In any event, the tunability of the response can greatly increase the adaptability and flexibility of the regulated system.

Commonality of biphasic response in biology is especially important to emphasize at the present stage of our exploration of the workings of the cell, when attempts at reconstituting regulatory networks underlying cellular function are increasingly made. For example, the use of various clustering algorithms for analysis of DNA array data is often aimed at inferring genetic networks that are likely to regulate the expression patterns observed. In such analyses it is commonly assumed that an element of a network can affect the other elements either positively or negatively. This assumption fails to describe the possibility of biphasic regulation and thus may lead to paradoxes and a decreased accuracy in network modeling. For example, a network element can be alternatively described as an activator or inhibitor, depending on the level of activation of the system. Since a biphasic biological response may be adjusted to respond at close to optimal value of the input, the simplified description of the regulation as either positive or negative can be especially difficult to make.

## REFERENCES

- Bell, B., Xing, H., Yan, K., Gautam, N. and Muslin, A.J. (1999) KSR-1 binds to G-protein betagamma subunits and inhibits beta gamma-induced mitogen-activated protein kinase activation. *J. Biol. Chem.* *274*, 7982-7986.
- Benoit, V., Hellin, A.C., Huygen, S., Gielen, J., Bours, V., Merville, M.P. (2000). Additive effect between NF-kappaB subunits and p53 protein for transcriptional activation of human p53 promoter. *Oncogene* *19*, 4787-94.
- Bronnikov, G.E., Zhang, S.J., Cannon, B., and Nedergaard, J. (1999). A dual component analysis explains the distinctive kinetics of cAMP accumulation in brown adipocytes. *J.Biol.Chem.* *274*, 37770-37780.
- Burack, W.R. and Sturgill, T.W. (1997). The activating dual phosphorylation of MAPK by MEK is nonprocessive. *Biochemistry* *36*, 5929-5933.
- Cacace, A.M., Michaud, N.R., Therrien, M., Mathes, K., Copeland, T., Rubin, G.M., and Morrison, D.K. (1999). Identification of constitutive and ras-inducible phosphorylation sites of KSR: implications for 14-3-3 binding, mitogen-activated protein kinase binding, and KSR overexpression. *Mol.Cell Biol.* *19*, 229-240.
- Carroll, S.B. (1990). Zebra patterns in fly embryos: activation of stripes or repression of interstripes? *Cell.* *60*, 9-16.
- De Koninck, P. and Schulman, H. (1998). Sensitivity of CaM kinase II to the frequency of Ca<sup>2+</sup> oscillations. *Science* *279*: 227-30.
- Dierick, H. and Bejsovec, A. (1999). Cellular mechanisms of wingless/Wnt signal transduction. *Curr.Top.Dev.Biol.* *43*, 153-190.
- Dyson, S. and Gurdon, J.B. (1998). The interpretation of position in a morphogen gradient as revealed by occupancy of activin receptors. *Cell* *93*, 557-568.
- Ferrell, J.E.J. and Machleder, E.M. (1998). The biochemical basis of an all-or-none cell fate switch in *Xenopus* oocytes. *Science* *280*, 895-898.
- Garrington, T.P. and Johnson, G.L. (1999). Organization and regulation of mitogen-activated protein kinase signaling pathways. *Curr.Opin.Cell Biol.* *11*, 211-218.
- Guillou, J.L., Nakata, H., and Cooper, D.M. (1999). Inhibition by calcium of mammalian adenylyl cyclases. *J.Biol.Chem.* *274*, 35539-35545.

- Hartwell LH, Hopfield JJ, Leibler S, Murray AW. (1999) From molecular to modular cell biology. *Nature*. 402(6761 Suppl), C47-52.
- Hasty, J., McMillen, D., Isaacs, F., Collins, J.J. (2001) Computational studies of gene regulatory networks: in numero molecular biology. *Nat Rev Genet*. 2(4), 268-79.
- Hoppler, S. and Bienz, M. (1995). Two different thresholds of wingless signalling with distinct developmental consequences in the *Drosophila* midgut. *EMBO J*. 14, 5016-5026.
- Huang, W. and Bateman, E. (1997) Transcription of *Acanthamoeba* TATA-binding protein gene. A single transcription factor acts both as an activator and a repressor. *J. Biol. Chem*. 272: 3852-3859.
- Iino, M. and Tsukioka, M. (1994) Feedback control of inositol triphosphate signalling by calcium. *Mol. Cell Endocrinol*. 98, 141-146.
- Keizer, J., Li, Y.X., Stojilkovic, S., and Rinzel, J. (1995). InsP3-induced Ca<sup>2+</sup> excitability of the endoplasmic reticulum. *Mol.Biol.Cell* 6, 945-951.
- Kieran, M.W., Katz, S., Vail, B., Zon, L.I., and Mayer, B.J. (1999). Concentration-dependent positive and negative regulation of a MAP kinase by a MAP kinase kinase. *Oncogene* 18, 6647-6657.
- Kristjuhan, A. and Maimets, T. (1995). Protein p53 modulates transcription from a promoter containing its binding site in a concentration-dependent manner. *Eur. J. Biochem*. 234, 827-831.
- Kristjuhan, A., Jaks, V., Rimm, I., Tooming, T. and Maimets, T. (1998) Oligomerization of p53 is necessary to inhibit its transcriptional transactivation property at high protein concentrations. *Oncogene*. 16, 2413-2418.
- Langeland, J.A., Attai, S.F., Vorwerk, K. and Carroll, S.B. (1994) Positioning adjacent pair-rule stripes in the posterior *Drosophila* embryo. *Development*. 120, 2945-2955.
- La Rosee-Borggreve, A., Hader, T., Wainwright, D., Sauer, F., and Jackle, H. (1999). hairy stripe 7 element mediates activation and repression in response to different domains and levels of Kruppel in the *Drosophila* embryo. *Mech.Dev*. 89, 133-140.
- Leskov, I.B., Klenchin, V.A., Handy, J.W., Whitlock, G.G., Govardovskii, V.I., Bownds, M.D., Lamb, T.D., Pugh, E.N. Jr., Arshavsky, V.Y. (2000). The gain of rod phototransduction: reconciliation of biochemical and electrophysiological measurements. *Neuron*. 27, 525-37.
- Levchenko, A., Bruck, J. and Sternberg, P.W. (2000). Scaffold proteins may biphasically affect the levels of mitogen-activated protein kinase signaling and reduce its threshold properties. *Proc.Natl.Acad.Sci.U.S.A*. 97, 5818-5823.

- Li, Y.X., Keizer, J., Stojilkovic, S.S., and Rinzel, J. (1995). Ca<sup>2+</sup> excitability of the ER membrane: an explanation for IP<sub>3</sub>-induced Ca<sup>2+</sup> oscillations. *Am.J.Physiol.* 269, C1079-C1092
- Mak, D.O., McBride, S., and Foskett, J.K. (1998). Inositol 1,4,5-trisphosphate [correction of tris-phosphate] activation of inositol trisphosphate [correction of tris-phosphate] receptor Ca<sup>2+</sup> channel by ligand tuning of Ca<sup>2+</sup>. *Proc.Natl.Acad.Sci.U.S.A.* 95, 15821-15825.
- Mak, D.O., McBride, S., and Foskett, J.K. (1999). ATP regulation of type 1 inositol 1,4,5-trisphosphate receptor channel gating by allosteric tuning of Ca(2+) activation. *J.Biol.Chem.* 274, 22231-22237.
- Maki, C.G. (1999). Oligomerization is required for p53 to be efficiently ubiquitinated by MDM2. *J. Biol. Chem.* 274: 16531-16535.
- McAdams, H.H. and Arkin, A. (2000). Towards a circuit engineering discipline. *Curr Biol.* 10(8), R318-20.
- McDowell, N., Zorn, A.M., Crease, D.J., and Gurdon, J.B. (1997). Activin has direct long-range signalling activity and can form a concentration gradient by diffusion. *Curr.Biol.* 7, 671-681.
- Motohashi, H., Katsuoka, F., Shavit, J.A., Engel, J.D. and Yamamoto, M. (2000). Positive or negative MARE-dependent transcriptional regulation is determined by the abundance of small Maf proteins. *Cell.* 103(6), 865-75.
- Palecek, S.P., Loftus, J.C., Ginsberg, M.H., Lauffenburger, D.A., and Horwitz, A.F. (1997). Integrin-ligand binding properties govern cell migration speed through cell-substratum adhesiveness. *Nature* 385, 537-540.
- Pryciak, P.M. and Huntress, F.A. (1998) Membrane recruitment of the kinase cascade scaffold protein Ste5 by the Gbetagamma complex underlies activation of the yeast pheromone response pathway. *Genes Dev.* 12, 2684-2697.
- Sauer, F. and Jackle, H. (1993). Dimerization and the control of transcription by Kruppel. *Nature* 364, 454-457.
- Schulz, C. and Tautz, D. (1994). Autonomous concentration-dependent activation and repression of Kruppel by hunchback in the Drosophila embryo. *Development* 120, 3043-3049.
- Schulz, C. and Tautz, D. (1995). Zygotic caudal regulation by hunchback and its role in abdominal segment formation of the Drosophila embryo. *Development* 121, 1023-1028.
- Shimizu, K. and Gurdon, J.B. (1999). A quantitative analysis of signal transduction from activin receptor to nucleus and its relevance to morphogen gradient interpretation. *Proc.Natl.Acad.Sci.U.S.A.* 96, 6791-6796.

- Sugiura, R., Toda, T., Dhut, S., Shuntoh, H., and Kuno, T. (1999). The MAPK kinase Pek1 acts as a phosphorylation-dependent molecular switch. *Nature* 399, 479-483.
- Taylor, C.W. and Marshall, I.C. (1992) Calcium and inositol 1,4,5-triphosphate receptors: a complex relationship. *Trends Biochem. Sci.* 17, 403-407.
- Uren, A., Reichsman, F., Anest, V., Taylor, W.G., Muraiso, K., Bottaro, D.P., Cumberledge, S., and Rubin, J.S. (2000). Secreted frizzled-related protein-1 binds directly to wingless and is a biphasic modulator of wnt signaling [In Process Citation]. *J.Biol.Chem.*2000.Feb.11.;275.(6):4374.-82. 275, 4374-4382.
- Watanabe, M. and Whitman, M. (1999). FAST-1 is a key maternal effector of mesoderm inducers in the early *Xenopus* embryo. *Development* 126, 5621-5634.
- Wu, X., Bayle, J.H., Olson, D. and Levine, A.J. (1993) The p53-mdm-2 autoregulatory feedback loop. *Genes Dev.* 7: 1126-32.
- Yi, T.M., Huang, Y., Simon, M.I. and Doyle, J. (2000) Robust perfect adaptation in bacterial chemotaxis through integral feedback control. *Proc Natl Acad Sci U S A* 97(9), 4649-53.
- Yu, X., Riese, J., Eresh, S., and Bienz, M. (1998). Transcriptional repression due to high levels of Wingless signalling. *EMBO J.* 17, 7021-7032.

**Box 1.** An example of computational analysis of a mechanism generating biphasic regulation

Here we show how the Type II biphasic regulation can be analyzed analytically. As described in the text, the Type II regulation arises when a regulated molecule (receptor) has two sets of binding sites of different affinity. In the simple case considered here only two binding sites are present. Binding of the regulator molecule (ligand) to the higher affinity site activates the receptor, whereas binding of the ligand to the lower affinity site inhibits the receptor. The inhibition resulting from the binding to the lower affinity site overrides the activation from binding to the higher affinity site. To generate the corresponding equations we consider the four possible receptor-ligand complexes: unbound receptor ( $r$ ), a single ligand molecule bound to the high affinity site ( $c_1$ ), a single ligand molecule bound to the low affinity site ( $c_2$ ), two ligand molecules bound to both binding sites ( $c_3$ ). The ligand concentration ( $l$ ) is present in all equations. The time evolution of each of these complexes is described by the corresponding equation in the systems given below:

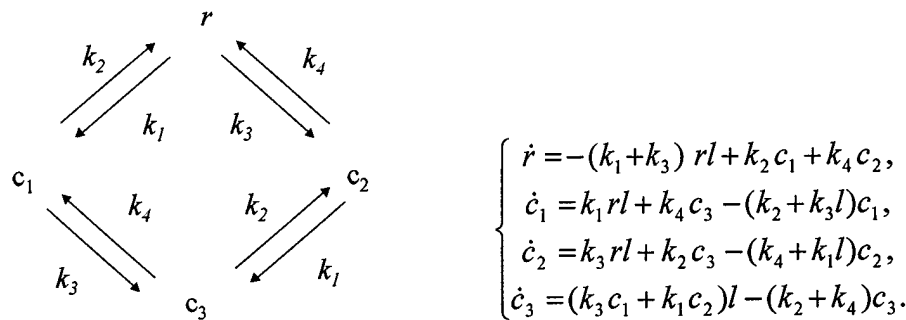

These equations show non-dimensionalized concentrations, with  $r$ ,  $c_1$ ,  $c_2$  and  $c_3$  normalized by dividing by the total receptor concentration, the  $l$  normalized by dividing by a characteristic (taken here to be half-maximal) ligand concentration and  $k_1$  and  $k_3$  normalized by multiplying by the half-maximal ligand concentration. Note that the equations are not independent and include implicitly the law of conservation of the total receptor number. Note also that it was assumed that binding of a ligand molecule does not affect the affinity of the other receptor binding site. Relaxation of this assumption can affect the results quantitatively rather than qualitatively. Here we opt to consider the simple case for the sake of illustration. The steady state solutions of the system (1) obtained by putting all the equations equal to zero show that the steady state complex concentrations depend on the equilibrium dissociation constants  $k_1/k_2$  and  $k_3/k_4$  rather than on the values of the individual rate constants. To estimate the receptor activation at various ligand concentrations we assume that receptor is active only when ligand is bound at the high affinity site (complex  $c_1$ ). Fig. S1 shows the solutions for  $c_1$  concentrations in non-dimensionalized coordinates. Increasing the affinity to the activating site resulted in higher magnitude responses with the maximum position shifting to lower ligand values (Fig. S1A). There is a concomitant increase in sensitivity of the response to variation of the ligand concentration. Decreasing the ligand affinity to the inhibitory site resulted in an increased amplitude of response with the maximum position shifting toward higher ligand concentrations (Fig. S1B). The sensitivity of response decreased. As in the Type I regulation high sensitivity generally may be achieved only at relatively low ligand concentration values. We can

conclude that variation of the two affinity parameters may locally adjust both amplitude and the position of maximum in any direction for a given receptor species.

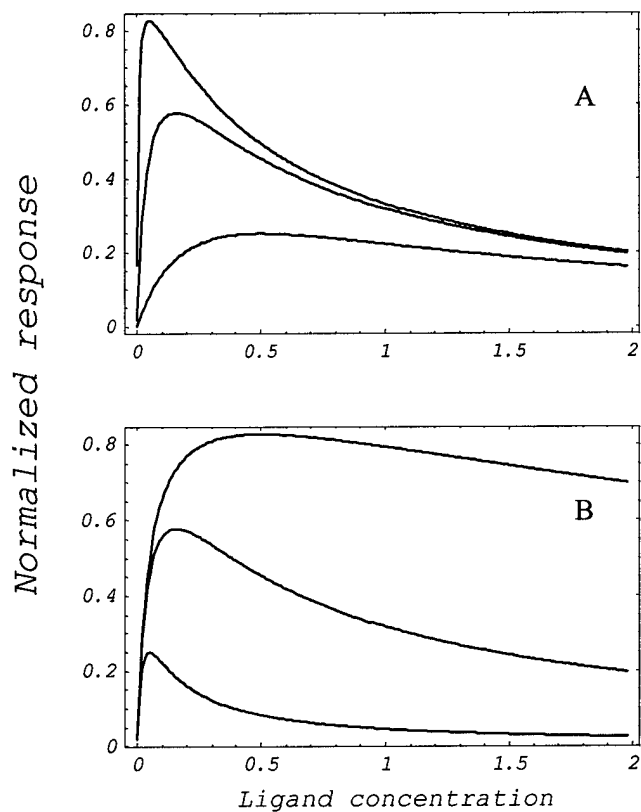

Figure 2.

Type II biphasic regulation: ligand can bind to low affinity activating and high affinity inhibitory sites in the receptor. A. Dependence on the ligand affinity to the activating site. The equilibrium dissociation constant is varied as 0.005 (upper curve), 0.05 (middle curve) and 0.5 (lower curve) concentration units with the dissociation constant for the inhibitory site being 0.5 units. B. Dependence on the ligand affinity to the inhibitory site. The dissociation constant is varied as 0.05 (upper curve), 0.5 (middle curve) and 5 (lower curve) concentration units. The dissociation constant for the activating site is 0.05 units. The response is normalized to the total receptor concentration.