

# REPORT DOCUMENTATION PAGE

Form Approved  
OMB No. 0704-0188

Public reporting burden for this collection of information is estimated to average 1 hour per response, including the time for reviewing instructions, searching existing data sources, gathering and maintaining the data needed, and completing and reviewing this collection of information. Send comments regarding this burden estimate or any other aspect of this collection of information, including suggestions for reducing this burden to Department of Defense, Washington Headquarters Services, Directorate for Information Operations and Reports (0704-0188), 1215 Jefferson Davis Highway, Suite 1204, Arlington, VA 22202-4302. Respondents should be aware that notwithstanding any other provision of law, no person shall be subject to any penalty for failing to comply with a collection of information if it does not display a currently valid OMB control number. PLEASE DO NOT RETURN YOUR FORM TO THE ABOVE ADDRESS.

1. REPORT DATE (DD-MM-YYYY)	2. REPORT TYPE Technical Paper	3. DATES COVERED (From - To)
-----------------------------	-----------------------------------	------------------------------

4. TITLE AND SUBTITLE	5a. CONTRACT NUMBER F04611-97-C-0031
	5b. GRANT NUMBER
	5c. PROGRAM ELEMENT NUMBER

6. AUTHOR(S)	5d. PROJECT NUMBER
	5e. TASK NUMBER
	5f. WORK UNIT NUMBER

7. PERFORMING ORGANIZATION NAME(S) AND ADDRESS(ES)  <i>Boeing</i>	8. PERFORMING ORGANIZATION REPORT
---	-----------------------------------

9. SPONSORING / MONITORING AGENCY NAME(S) AND ADDRESS(ES)  Air Force Research Laboratory (AFMC) AFRL/PRS 5 Pollux Drive Edwards AFB CA 93524-7048	10. SPONSOR/MONITOR'S ACRONYM(S)
	11. SPONSOR/MONITOR'S NUMBER(S)

12. DISTRIBUTION / AVAILABILITY STATEMENT  
  
Approved for public release; distribution unlimited.

13. SUPPLEMENTARY NOTES

14. ABSTRACT

20020828 201

15. SUBJECT TERMS

16. SECURITY CLASSIFICATION OF:			17. LIMITATION OF ABSTRACT  A	18. NUMBER OF PAGES	19a. NAME OF RESPONSIBLE PERSON Leilani Richardson
a. REPORT Unclassified	b. ABSTRACT Unclassified	c. THIS PAGE Unclassified			19b. TELEPHONE NUMBER (include area code) (661) 275-5015

*Item enclosed*

PLVTDVD

TP-FY99-0145

✓ Spreadsheet  
✓ DTS

MEMORANDUM FOR PRS (Contractor/In-House Publication)

FROM: PROI (TI) (STINFO)

17 June 1999

SUBJECT: Authorization for Release of Technical Information, Control Number: AFRL-PR-ED-TP-FY99-0145  
Partch and Frye (Boeing), "Solar Orbit Transfer Vehicle Conceptual Design"  
AIAA JPC

(Public Release)

## Abstract

In response to government and industry needs for greater space lift capability, greater space mobility, and more affordable spacecraft, the Air Force Research Lab has been researching advanced technologies that include solar thermal propulsion and solar thermionic based power systems. Efforts over the last ten years have focused on feasibility, design, and fabrication issues of the various components. Recent programs have progressed to the point of ground based demonstrations of major subsystems. Because solar thermal based concepts are designed to make use of the 0-g space environment, the validation of several key issues can only be accomplished with a space flight experiment. These issues include the long duration containment and acquisition of two-phase hydrogen, stability and dynamic control of large solar concentrators, exhaust plume impingement, and autonomous multi-impulse orbit raising.

In an effort to validate these issues, a conceptual design of a space experiment has been created which includes basic layout and design drawings, performance predictions, and subsystem requirements. The design was produced using a design to cost approach. This paper gives a basic overview of the conceptual design as well as a description of the drivers and rationale behind the design. The DTC method shows to be a valuable tool for defining low cost technology experiments although the results must be considered in the light of the driving factors.

## Introduction

In the commercial and government space sectors, the high cost of launching assets into orbit has been both a hindrance and the target of many programs trying to achieve affordable access to space. Although the launch costs are dominated by the effort to get a payload from the ground

into orbit, the efficiency of the orbit transfer stage does have a major impact for missions going to higher orbits such as geostationary. A more efficient transfer stage will use less fuel and can effectively double the mass of useful payload that can be lifted by a launch vehicle. Not only can a more efficient space propulsion system move heavier payloads; it can allow the creation of a space vehicle with significantly more velocity change capability. This increased mobility allows a space tug vehicle to become feasible. A space tug would be able to rescue satellites that failed to reach proper orbit, retrieve satellites for servicing or upgrade, and be able to move satellites to new orbits part way through their life.

Once any vehicle has reached orbit, the propulsion system trade-off between thrust level and Isp changes significantly. The traditional chemical thermal propulsion based systems are inherently limited to about 450 sec Isp using cryogenic oxygen and hydrogen. To enable space vehicles with dramatic increases in propulsive capability, a much higher Isp technology must be used. This requires a separation of the propellant from the energy used to accelerate it. Ion, Hall effect, arcjet, nuclear thermal, and solar thermal are all examples of advanced propulsion concepts. The advantages of solar thermal are that it is safer and politically more acceptable than nuclear thermal, and has a higher energy efficiency than the electric propulsion systems. Although Hall effect and ion engines offer an Isp of 1500 – 4000 seconds compared to 800 seconds for solar thermal, the mass associated with creating the electric power can be a penalty for some applications. Solar thermal propulsion offers a compromise between propellant efficiency and energy efficiency that can be very advantageous for certain mission applications.(1,2,3,4)

## Basics of Solar Propulsion

Solar thermal propulsion is a very simply low pressure fed rocket that uses focused sunlight to heat the propellant

before it accelerates out a nozzle. This allows a system to be as reliable as a cold gas thruster but able to achieve 800 seconds or more Isp when using hydrogen as a propellant. At earth distances from the sun, a heat exchanger can reach 2500 K or higher by concentrating the sun's radiation by a factor of close to 10000. This is generally accomplished by using reflective paraboloid mirrors that point at the sun and place the focal spot on the heat exchanger. Figure 1 shows an artist's concept of a vehicle that is propelled by solar propulsion. The concentrators are clearly visible as is the propellant tank that could hold either cryogenic hydrogen or a storable propellant. Because applications place different constraints on a vehicle, some concepts make use of a thermal storage medium in conjunction with the heat exchanger. These systems can then make dual use of the concentrators by also powering thermionic diodes to produce electrical power. Incorporation of thermionic power production enables a bi-modal concept. Figure 2 shows one arrangement of an array of diodes that would be placed around a cylindrical thermal storage device.

As these technologies have progressed, a number of component and subsystem ground tests have been conducted. These have included fabrication and tests of the heat exchanger's capability to withstand 2500 K thermal cycles without leaking hydrogen, fabrication and tests of large deployable mirrors with sufficient surface accuracy, and integrated tests of the mirror and heat exchanger optical train.(5,6,7,8,9,10,11,12) The success thus far has prompted the development of several applications at the conceptual level. Although the solar propulsion and thermionic power production technologies are based on simple principles, incorporating them into a vehicle involves unique challenges. The concentrators must be pointed to within 0.1 degrees for extended durations and deployment and vibration dynamics of the large precision mirrors must

be controlled. The tank system must maintain a cryogenic fluid for weeks or longer and be able to acquire propellant in a micro-gravity environment. Furthermore, optimum sizing of the propulsion system requires the vehicle to perform dozens of burns in a multi-impulse maneuver to perform significant orbit changes. The validation of these issues with an integrated system can only be adequately performed by means of a space flight experiment.(13,14,15,16)

### **Driving Requirements**

To investigate this space experiment need, the Air Force Research Laboratory initiated an effort to better define a space experiment that could both satisfy the technical needs and fit with in programmatic constraints. The constraints that were known at the time were to validate technologies in a type and size that are traceable to an operational system, create a design that is compatible with a Taurus class launch vehicle, and to define a program to accomplish the experiment that would not exceed \$30 million.(17,18) The operational system that was selected as the reference mission was an orbit transfer stage that would deliver payloads from LEO to GEO.(19) Although it was desired to have the experiment follow this mission as closely as possible, the other constraints pushed for a concept which was heavier and less ambitious. Table 1 compares the mission parameters that were derived for several space experiment options with the parameters of the operational reference mission. Although the experiment was scaled down significantly, it represented a good technical solution that conformed to the constraints.

The conceptual design parameters were selected from the trade space by means of a Quality Function Deployment (QFD) exercise. QFD is defined as a systematic approach to product development that translates customer needs into program requirements, creates a product that is customer driven, and produces a cost-

effective product. The key output of using the QFD prioritizing approach is a House of Quality matrix that correlates customer requirements to design requirements. The matrix shown in Figure 3 includes the ranked customer requirements, design requirements, and the relationship matrix between the two lists. Also included are the objective target values, an engineering competitive assessment, and the technical importance rating for each of the design requirements. The QFD matrix shows that the strongest Air Force wants were to meet the cost and launch vehicle constraints while still achieving a technically traceable system. This drove the highest priority methods for the effort to include basing the design on tested hardware and performance, using a Design To Cost (DTC) approach, delivering a representative Isp, and producing as much orbital velocity change as constraints will allow.

The incorporation of a DTC approach created an iterative design process. Program cost target values were determined and allocated to the sub-systems as individual cost targets. The DTC process works to balance the top-down allocation of cost targets with the bottom-up detail cost estimates to ensure that program targets are realistic and achievable. The process is a disciplined approach to refining the product design through iterations of improvement efforts that ensure that all program requirements are satisfied. Various options are explored at all levels in the effort to meet technical and cost targets. Figures 4 and 5 show the relationships between the cost targets and the engineering estimates for the space experiment. It can be seen that although the engine receiver was expected to be the most expensive component, the concentrator had significant difficulty in trying to reach its target and ended up being one of the major cost drivers.

The final cost estimation based on a bottoms up costing approach was within 10% of the cost target. This was considered sufficient since the experiment was still in

the conceptual development phase. Not all subsystems achieved their original cost goal but number of trades were performed in an effort to reduce the cost as much as possible. The concentrator subsystem started at roughly 300% of its cost target. Cost based decisions were made to only fly one concentrator instead of two, to reduce test support labor, and to reduce the complexity of the boom gimbals. These all increased technical and program risk. Several hinges and motors were eliminated which increased the needed fairing size and mirror facet size was increased with a corresponding reduction in optical quality. All combined, these trades brought the concentrator subsystem down to 160% of its cost target. The heat exchanger subsystem started at 150% of its target and progressed to the target value by means of the following choices. The fabrication of complete hardware was limited to one unit for ground testing and one for flight. The designs of the thermionic converters and the secondary concentrator would be based on previously tested hardware without effort to improve their performance. Finally, no life testing of the exchanger would be performed and the flight would rely on the partial life data gathered in previous ground testing. These choices added risk to the experiment and moderately reduced the expected performance. Several trade decisions were also made for the spacecraft bus. The bus components were selected based on lowest cost for off the shelf hardware. These included items that exceeded needs and added mass and power penalties but were less costly than custom components. Residual solar panel hardware from other programs was also found which could be adapted for use and saved significant costs.

#### **Space Experiment Design**

The conceptual design shown in Figure 6 was the final result of the effort. The propellant tank was cylindrical in shape and sized to fit with in the Taurus payload fairing. The spacecraft bus contained the attitude control, communication, and

processing. It was located at the opposite end of the spacecraft from the thruster and heat exchanger, which is also referred to as the receiver, absorber, converter (RAC). The RAC was attached to the propellant tank by the engine interface structure that contained movable flexures. This allowed the thrust vector to be controlled as the spacecraft center of gravity changed during flight. The concentrator subsystem was attached to the RAC structure such that motion of the engine interface structure would not effect the alignment of the concentrator. The concentrator is supported and controlled by several struts with gimbaled joints. This provided both the ability to deploy the concentrator from its launch packaged state and to allow both course and fine pointing control during operation. A more detailed description of the subsystem design and rationale is given next.

### Concentrator Subsystem

The intent of the concentrator design was to minimize the mass while maintaining a view half angle of 30 deg. The choice of 30 deg was based upon previous optimization and because it was tracable to ground test hardware. (20,21) Approximately 3.9 m<sup>2</sup> of projected facet area were required to provide sufficient power to the aperture. Therefore, the focal length became 120 in. for a 30 deg offset angle. The true area of the concentrator is 4.5 m<sup>2</sup> and was attached in the middle by a single boom. Between the spacecraft and concentrator are two 2-axis gimbals for all pointing motions. The most effective use of stowage volume is to utilize the available length of the envelope and minimize the width of the envelope required. The design has hinged panels that wrap around the tank. This creates a stowed volume that is 110 in. in length and 10 in. thick. Figure 7 shows how the stowed configuration would appear.

The concentrator is comprised of 12 rectangular graphite epoxy facets with a replicated epoxy face sheet, a silver reflective layer and a SiOx protective

overcoat. They contain a toroidal curvature with a series of ribs co-cured to provide stiffness. This method of manufacturing is based upon demonstrated and ground tested hardware under previous programs. Typical performance of the concentrator components are listed in Table 2. Some of the design trade rationale is described in Table 3.

### RAC Subsystem

The purpose of the RAC is to convert the high intensity sunlight into thermal energy. This is accomplished by using a graphite black body cavity with high temperature insulation around the outside. This high temperature thermal storage medium enables the ability to have thermal energy available throughout the orbit including any eclipse time. The propellant absorbs this thermal energy during propulsion modes and the thermionic diodes are driven by the thermal energy in power mode. Figure 8 illustrates several of the major components of the RAC that are directly expected to be derived from previous ground testing. (22,23,24) The majority of the design features and manufacturing processes were the same. However, component size was scaled down and fewer thermionic diodes were planned to reduce cost and risk of unexpected heat leaks. Some improvements to the insulation design were included, because the additional cost of validating a modified design was deemed acceptable for the expected performance improvement.

The graphite thermal storage cylinder was designed to be CVD coated with rhenium on both the inside flow tubes and on the outside. This protected the graphite from both the hydrogen and from sublimating at high temperature. It also provided structural bonding of the four sections of the absorber. Limiting high temperature creep of the rhenium to 2% was the structural design driver for the CVD thickness.

The optical secondary concentrator was designed with a compound parabolic shape.

Because of the close proximity to the high temperature cavity and due to the direct illumination of the high intensity sunlight, the secondary concentrator was designed to operate at temperature without active cooling. The structural backing was graphite with coatings of rhenium and then iridium. Iridium is 74% reflective to sunlight and 87% reflective to blackbody radiation at 2300 K. This design was based on previously tested designs and was followed due to cost constraints.

The design for the thermionic diodes was based upon hardware that had been fabricated for ground tests although the tests had not yet been completed. The diode array consisted of the diodes, alumina spacers, electrical conductors, graphite fiberform, and felt insulation. The diode design contains a hot shoe and emitter, an electrical collector, and a sodium heat pipe to discard the waste energy. The spacers provide electrical isolation and closely control the spacing of interfacing thermal insulation. The diodes are rigidly mounted through the spacers to the frame, which also supports the diode array insulation. When installed on the RAC, it properly positions the diode hot shoes next to the thermal storage device.

The high temperature insulation design was an evolution from previous ground test efforts. Graphite felt and multi layer insulation combination was selected as the best approach. The cylindrical portion of the receiver was to be wrapped with graphite felt. Tungsten multi layer insulation was to be used on the end caps where the insulation is not curved and space for thick insulation does not exist. The area adjacent to the thermionic diodes was to be insulated using fiberform because it can be better held in place and thus avoid electrical shorting of the diodes. A thin shell of nickel foil sheet would enclose the fiber felt to further enhance the thermal resistance and to shield against the migration of contaminants or graphite dust.

### **Propellant Storage and Feed**

The propellant storage and feed subsystem stores liquid hydrogen during the several week mission and vents higher quality  $H_2$  to maintain nearly constant tank pressure. All of the vented hydrogen is used in the thrusters during propulsion operations. The system uses environmental heat flux for pressurization of the tank and delivery of the propellant. Excess heat is removed by having the vented hydrogen pass through active and passive thermo-dynamic vent systems. A schematic of the components is shown in Figure 9. The design is based on hardware that has been ground tested. (25,26,27,28)

During the design effort, three primary trade studies were conducted. Aluminum was selected for the experiment tank since it is a low-cost material with excellent properties at cryogenic temperatures. A composite tank would have been lighter but would be more expensive and has had less testing with hydrogen. A second trade considered increasing the size of the thermo-dynamic vent system or increasing the amount of multi layer insulation to slow the pressurization rate. It was felt that a larger vent system would be less expensive with out significant weight impact. The final trade involved assessing the need for a quantity mass gauging system. A quantity gauge or a mass flow gauge would provide a direct measurement of the propellant flow rate but either flight rated cryogen gauge would be comparatively expensive and have questionable accuracy. A low-pressure drop venturi was selected to measure the flow down stream where the propellant had already gasified. This provided the most cost-effective choice to obtain the needed information.

### **Bus subsystem**

The requirement of the bus subsystem was to provide the spacecraft power, communications, flight management, attitude determination, and reaction control. The design was carried out with emphasis on finding low cost, flight proven

components and approaches.(29) It was determined that momentum wheels would add system flexibility but were too costly since small attitude thrusters could maintain pointing to 1 deg. This pushed more of the pointing requirement onto the concentrator system but provided significant savings on the bus. The power system was designed around existing solar cells that might be available at no cost and were designed to mount on one side of the propellant tank. This again reduced flexibility in operation of the spacecraft but provided a more simple and economical design. S band communications was selected due to the greater availability and affordability of components and a decision to rely on the Air Force SGLS was based on avoiding custom control units or more expensive transponders. The shape and construction of the bus structure was selected to be hexagonal to allow lower cost manufacturing and modular assembly. Although these choices added to the mass of the experiment and reduced its flexibility, they allowed a design close to the cost target.

### Conclusion

A conceptual design of a flight experiment was produced which represents the necessary next step in developing and proving the solar thermal propulsion and power technologies. This conceived experiment will validate the space related issues of the technology and allow the follow on development of operational advanced upper stages, space tug architectures, and high mobility vehicles which will allow in-space servicing of assets. In addition to providing a method to demonstrate integrated system performance and operation, the low gravity environment will be used to:

- Demonstrate concentrator pointing and tracking and thermal management
- Validate low-g LH<sub>2</sub> acquisition, storage and supply
- Validate low-g operation of advanced static power converters

- Provide multi-impulse low-thrust propulsion performance data
- Demonstrate integrated propulsion and power system

To meet the above objectives under the constraints of a very aggressive cost goal and limited selection of launch vehicles, a design to cost methodology was implemented that defined a cost-driven space experiment design. Several of the cost drivers were identified and included:

- Level of component and subsystem testing
  - Technology maturity
  - Unknowns about flight readiness
  - Experiment size/launch vehicle volume constraint
  - Experiment power requirement
  - Mission duration

Although a conceptual design was developed which met all the requirements, the cost constraint was achieved at the expense of system performance and increased risk. The experiment was reduced in both the size and the thermal power available for propulsion and electrical conversion. Hardware such as the propellant tank was designed for low cost instead of being lightweight. The reduction in power and increase in component mass significantly reduced the Delta-V capability of the experiment. However, the subscale design still achieved the defined objectives. To further reduce cost, engineering test units and subsystem performance tests were removed from the plan. This meant that designs had to more closely follow previously tested hardware even though many areas have been identified where the technology can be improved. These choices make sense in the light of a cost constrained approach and a level of risk consistent with a class D experiment. Although most of the components proposed for the flight have reached a

TRL level between 5 and 7, there is still a significant research effort needed for the concentrator and absorber technologies to increase their performance and life capability to the level needed for operational use. This additional research effort is expected to continue concurrently with the space experiment program.

## REFERENCES

1. Ford, C. R.; "Solar Thermal Propulsion for Orbit Transfer Vehicles"; AIP 5<sup>th</sup> Space Nuclear Power Symposium 1988
2. Frye, P. E. and Miller, T. M.; "Impact of Future Launch Systems on Solar Orbit Transfer Vehicle Payoffs"; Presented at the 1998 Space Technology and Applications International Forum; January 1998
3. Frye, P. E.; "Reusable OTV Design Concept"; AIAA Paper 98-4029; July 1998
4. Perkins, D., *Future Air Force Upper Stage Propulsion Considerations*, AIAA-97-2984, July 1997.
5. Frye, P. and Kudija, C., *Integrated Solar Upper Stage Engine Ground Demonstration Test Results and Data Analysis*, AIAA-98-3958, July 1998.
6. Schmidt, G. R.; "Propulsion Research and Technology at NASA Marshall Space Flight Center"; AIAA Paper 98-3230; July 1998
7. Shoji, J. M., Frye, P. E., Chwiedor, T. D., and Lim, D. P.; "Advanced Absorber/Thruster Concepts for Solar Thermal Propulsion"; Presented at the ASME Solar Energy Forum, April 1993
8. Shoji, J. M., McClanahan, J. A., and Frye, P. E.; "Solar Thermal Propulsion System Technology Status Assessment"; 1993 JANNAP Propulsion Meeting, November 1993
9. Laug, K.; "The Solar Propulsion is Alive and Well at the Astronautics Laboratory"; CPIA Publication 515, Vol. I, pp 289-324, 1989
10. Schumacher, K. M. and Adams, M. A., *Solar Concentrators for Advanced Solar Dynamic Power Systems in Space Final Report*, NASA Contract NAS3-25413, August 1989.
11. Knasel, D., Ehresman, D., *Solar Concentrator Advanced Development Program*, NASA-CR-185173, October 1989.
12. Alexander, D., *2 kWe Solar Dynamic Ground Test Demonstration Project*, NASA-CR-198423, February 1997.
13. Curtis, L. A. and Toelle, R. G.; "Solar Thermal Propulsion Shooting Star Experiment"; Presented at the 1998 Space Technology and Applications International Forum; January 1998
14. McClanahan, J. A. and Frye, P. E.; "Solar Thermal Propulsion Transfer Stage Design for Near-Term Science Mission Applications"; AIAA Paper 94-2999, June 1994
15. Thomas, M.; "Flight Experiments for Large Inflatable Parabolic Reflector"; Proceedings of the ASME International Solar Energy Conference, pp.361-368, April 1993.
16. Cady, E. and Olsen, A. Jr. "Solar Thermal Upper Stage Technology Demonstrator Program," AIAA 96-3011, AIAA 32nd JPC, 1996.
17. Knight, F., Evolved Expendable Launch Vehicle Standard Interface Specification Version 3.4, The Aerospace Corporation, July 1997.
18. Orbital Sciences Corporation, Commercial Taurus Launch Vehicle Payload User's Guide, Release 2.0, April 1996.
19. Frye, P. E. and Law, G.; "Solar Bimodal Mission and Operational Analysis"; 1996 Space Technology and Applications International Forum; pp. 1487-1504, January 1996
20. Borell, G. J.; "Rigid Deployable Solar Concentrators for Advanced Upper Stage Systems"; Presented at 1997 Space Technology and Applications International Forum; January 1997
21. Laxton, J., Lawandowski, C., Wilson, D., and Borell, G.; "ISUS Engine Ground Demonstration Solar Concentrator Design and Testing"; Presented at the 1998 Space Technology and Applications International Forum; January 1998

22. Markham, G. T. and Ales, M. A.; "High Temperature Solar Receiver Cavity for ISUS"; Presented at 1997 Space Technology and Applications International Forum; January 1997
23. Westerman, K. O. and Miles, B. J.; "Testing of a Receiver-Absorber-Converter (RAC) for the Integrated Solar Upper Stage (ISUS) Program"; 1998 Space Technology and Applications International Forum; pp.375-380, January 1998
24. Fortuni, A. J. and Tuffias, R. H.; "Design and Fabrication of Solar Thermal Propulsion System"; 1996 Space Technology and Applications International Forum; pp. 1447-1452, January 1996
25. Cady, E. and Olsen, A. Jr. "Cryogen Storage and Propellant Feed System for the Integrated Solar Upper Stage (ISUS) Program," AIAA 96-3044, AIAA 32nd JPC, 1996
26. Bailey, W., Weiner, S., Beekman, D., Dennis, M., Martin, T., *Cryogenic On-Orbit Liquid Depot Storage, Acquisition, and Transfer Satellite (COLD-SAT) Feasibility Study*, NASA-CR-185247, June 1990.
27. Lin, C.S., Van Dresar, N.T. and Hasan, M.M. "A Pressure Control Analysis of Cryogenic Storage Systems," AIAA 91-2405, AIAA 27th JPC, 1991.
28. Cady, E. C.; "Solar Thermal Upper Stage Technology Demonstrator, Liquid Hydrogen Storage, and Feed System Program"; 1997 Space Technology and Applications International Forum; pp.467-472, January 1997
29. A. R. Frederickson, "Leaky Insulating Paint for Preventing Discharge Anomalies on Circuit Boards," IEEE NS 36, 2405, 1989.

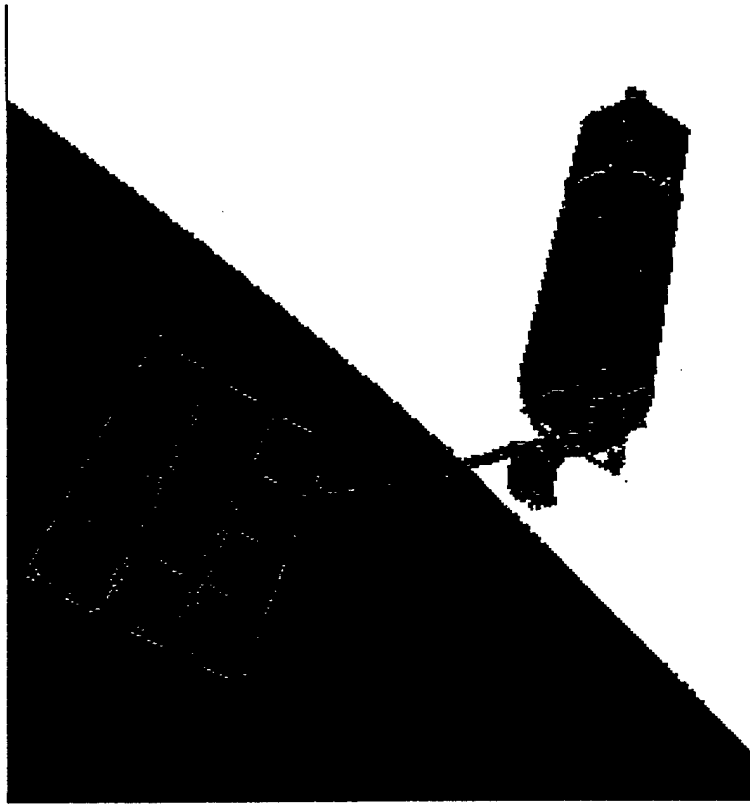

Fig. 1

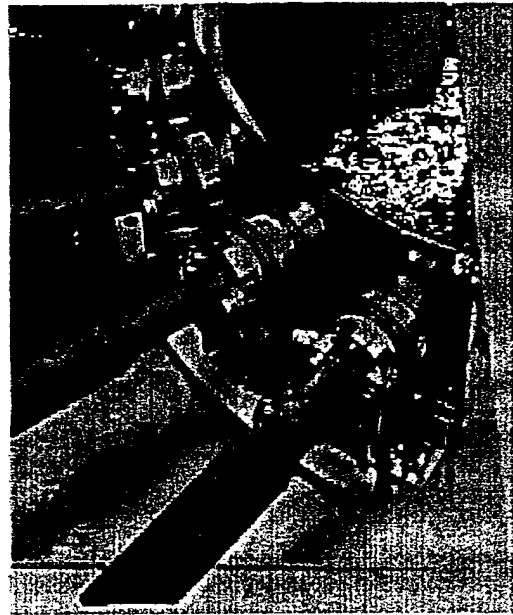

Fig 2.

**CUSTOMER WANTS & REQUIREMENTS**

5] Identify how to perform \$30M Space Demo

5] Provide a conceptual design TI and STP system

4] Design which includes the traceable path to one or more operational systems

4] Design compatible with free launch

3] Design with enough detail in concept and schedule to be believable and convincing

3] Has low enough risk to work

2] Design of demo that has "WOW" appeal

1] Study to include major cost drivers and sensitivities

Importance (Rated 1 thru 5) 6/97

TYPE	MEASURES (how to satisfy customer wants)	Measure effective for satisfying the requirement? (null, 1, 3 or 9)								GOAL (value of measure)	SCORE (in 6/97)
Max	Based on tested hardware	9	3	1	1	9	9			% @ TRL > 6	122
Target	Design utilizes TI & STP	3	9	9	1	1		9		Yes	117
Target	Mission DV	9		9	1			9		2500 m/s	103
Target	Use DTC, CAIV	9	3	1	1	3	3	9		Yes	95
Max	% Cost related to test article	9		1		9	3	1	3	78% Est Cost	90
Target	Specific impulse		3	9		1		9		750 sec	72
Target	Conceptual drawings		9		3	3		3		Yes	72
Max	Looks like real system		3	9				9		0.8	69
Target	% Cost related to testing	9				3	3		3	15% Est Cost	66
Target	Cavity temperature	3	1	9			3			< 2300 K	65
Min	Single point failures	3		3		3	9			Zero	63
Target	Compatible w/ multiple payloads	3		1	9			3		Yes	61
Min	Deployed/active components	3		1		3	9		1	Zero	56
Target	Launch processing timeline/reqs	1		1	9	3		1		Yes	55
Target	Space experiment volume	3			9	1				Taurus/EELV1	54
Target	Mission duration (CONOPS)	3	1		3		3	3		> 90 days	47
Target	Expert review	1		1		9	3	1		Yes	47
Target	# of defined margins	1	1	3	1	3	3			10	44
Target	Specific power			9				3	1	> xx W/kg	43
Target	Optical efficiency/effectiveness			9				3	1	Watts into RAC/kg	43
Target	Thermal capacity	1	3	1				3		xx mega-Joule	30
Target	Power level	3	1	1	1			1		500 Watts electric	30
Max	Innovation in operation	3		3				1		Yes	29

Fig 3

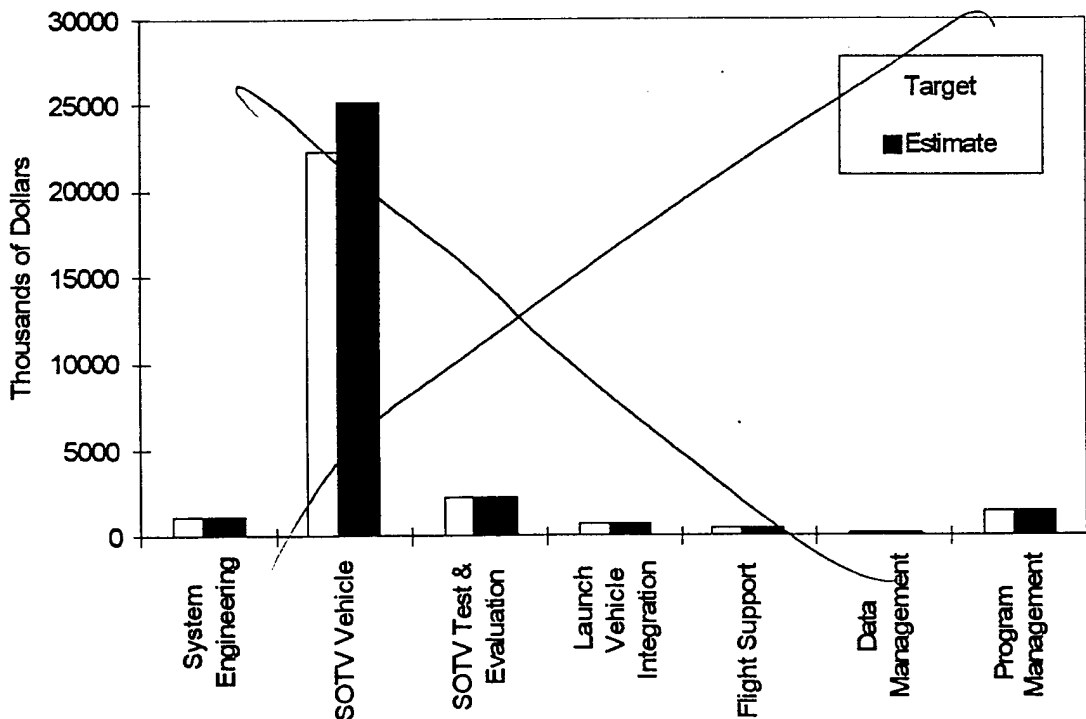

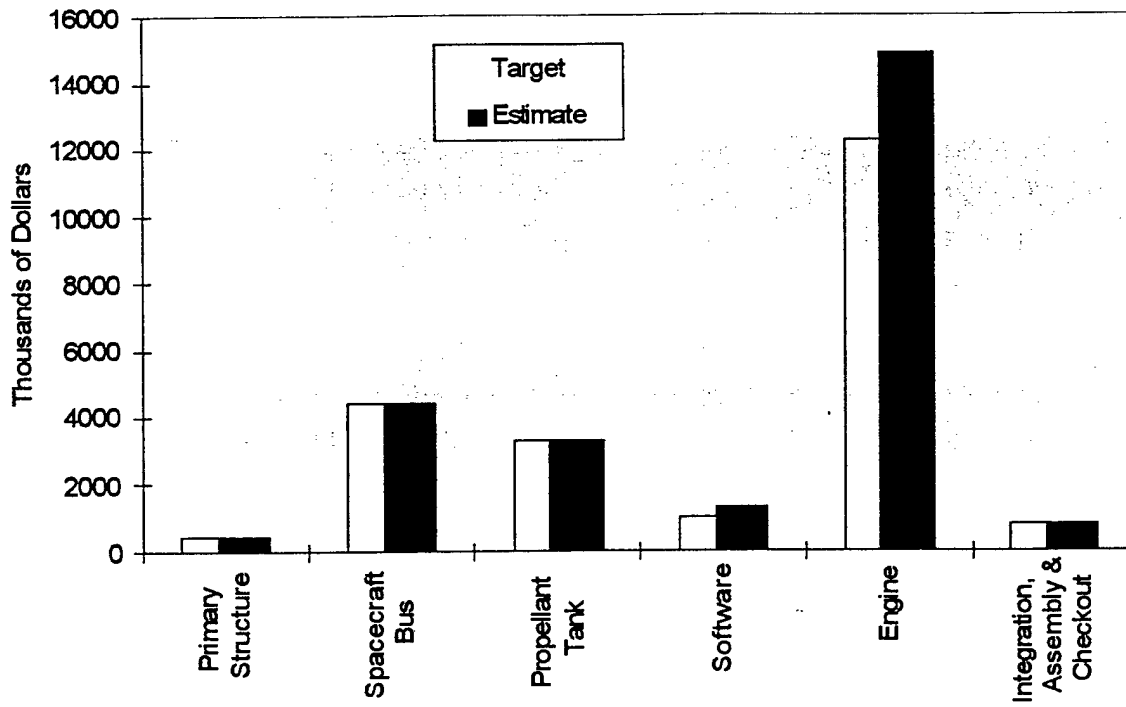

Fig 4

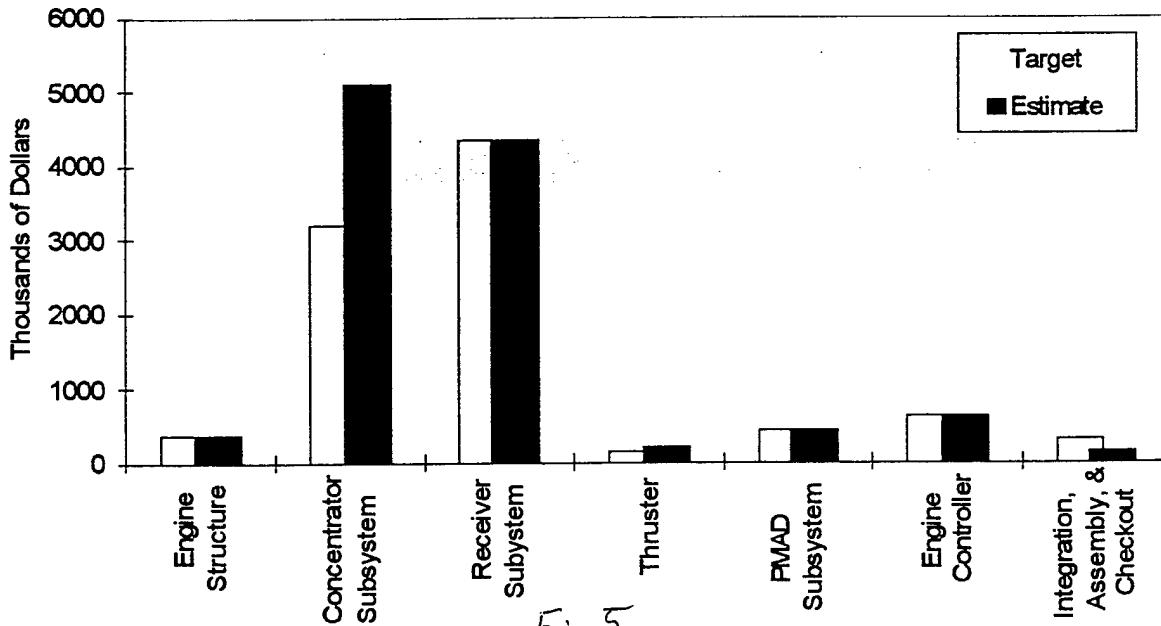

Fig 5

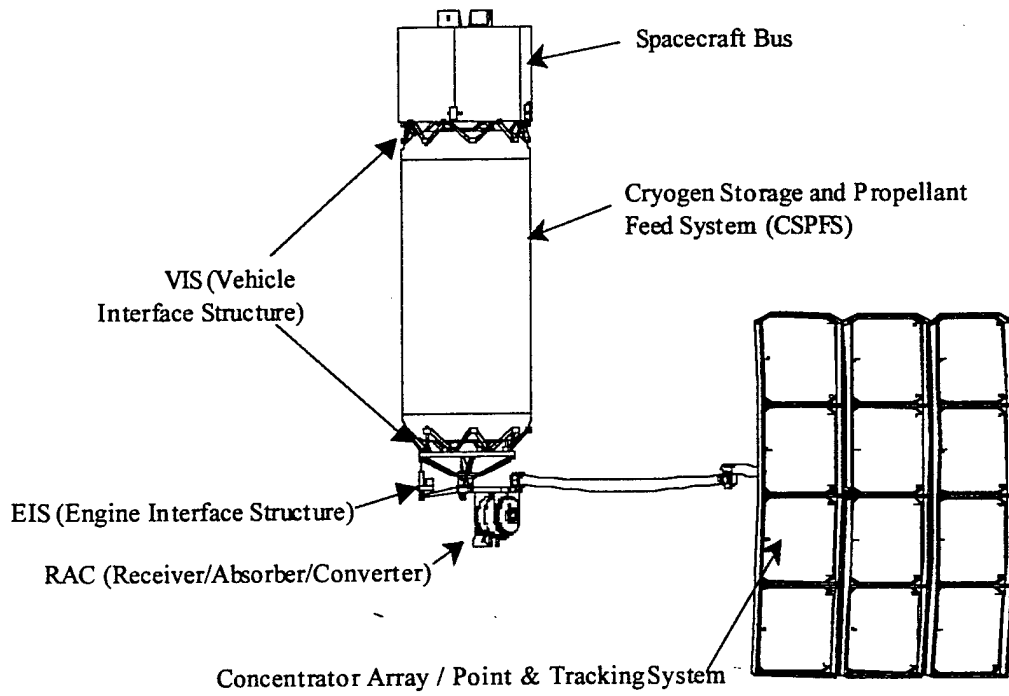

Fig 6

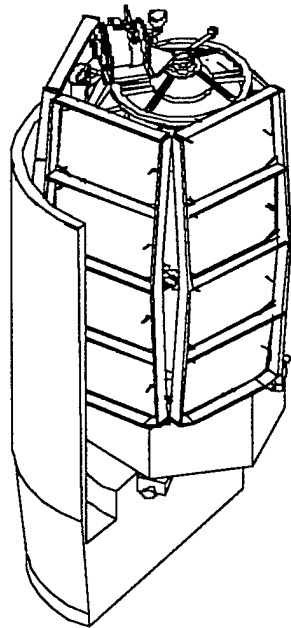

Fig 7

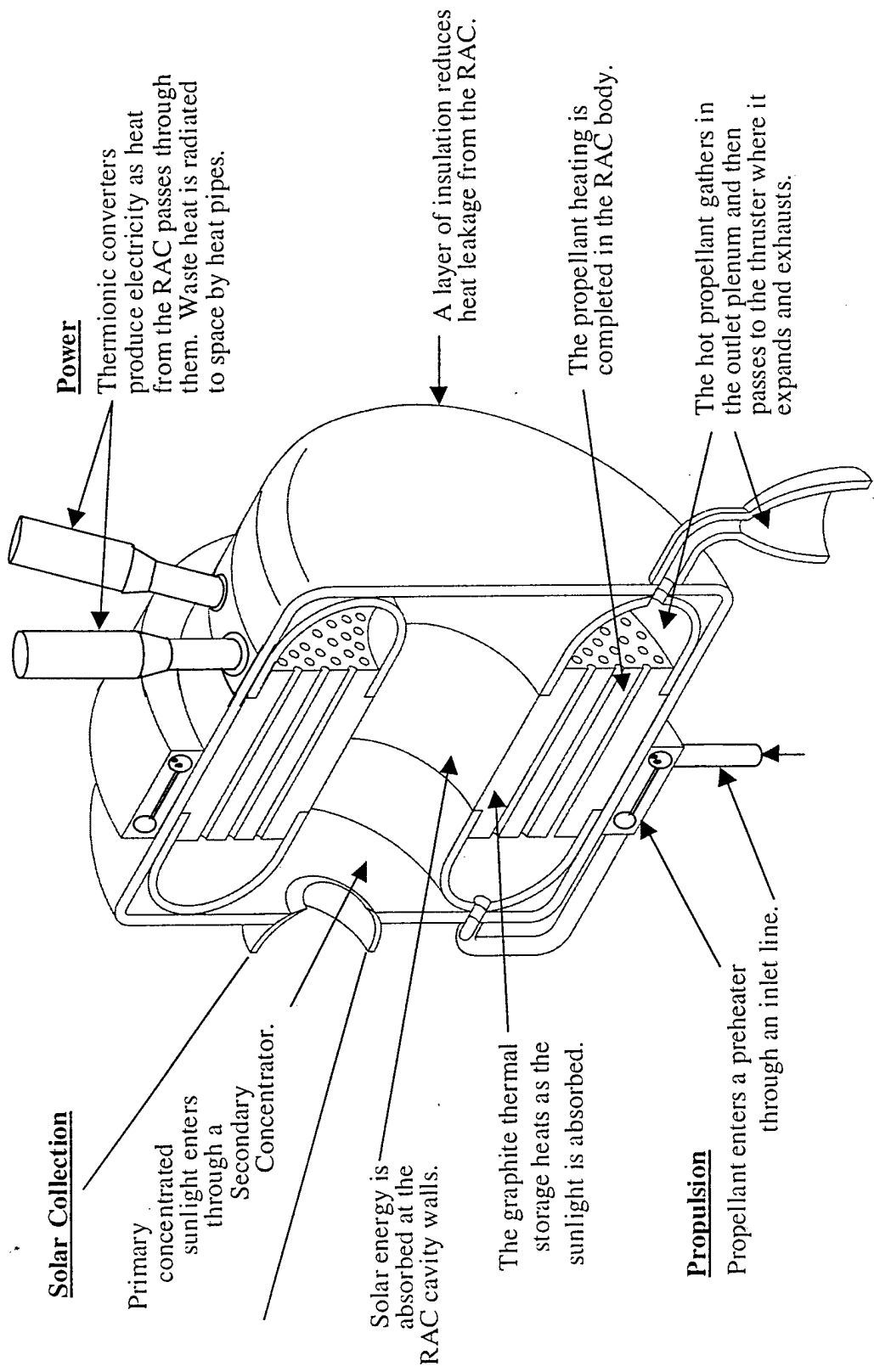
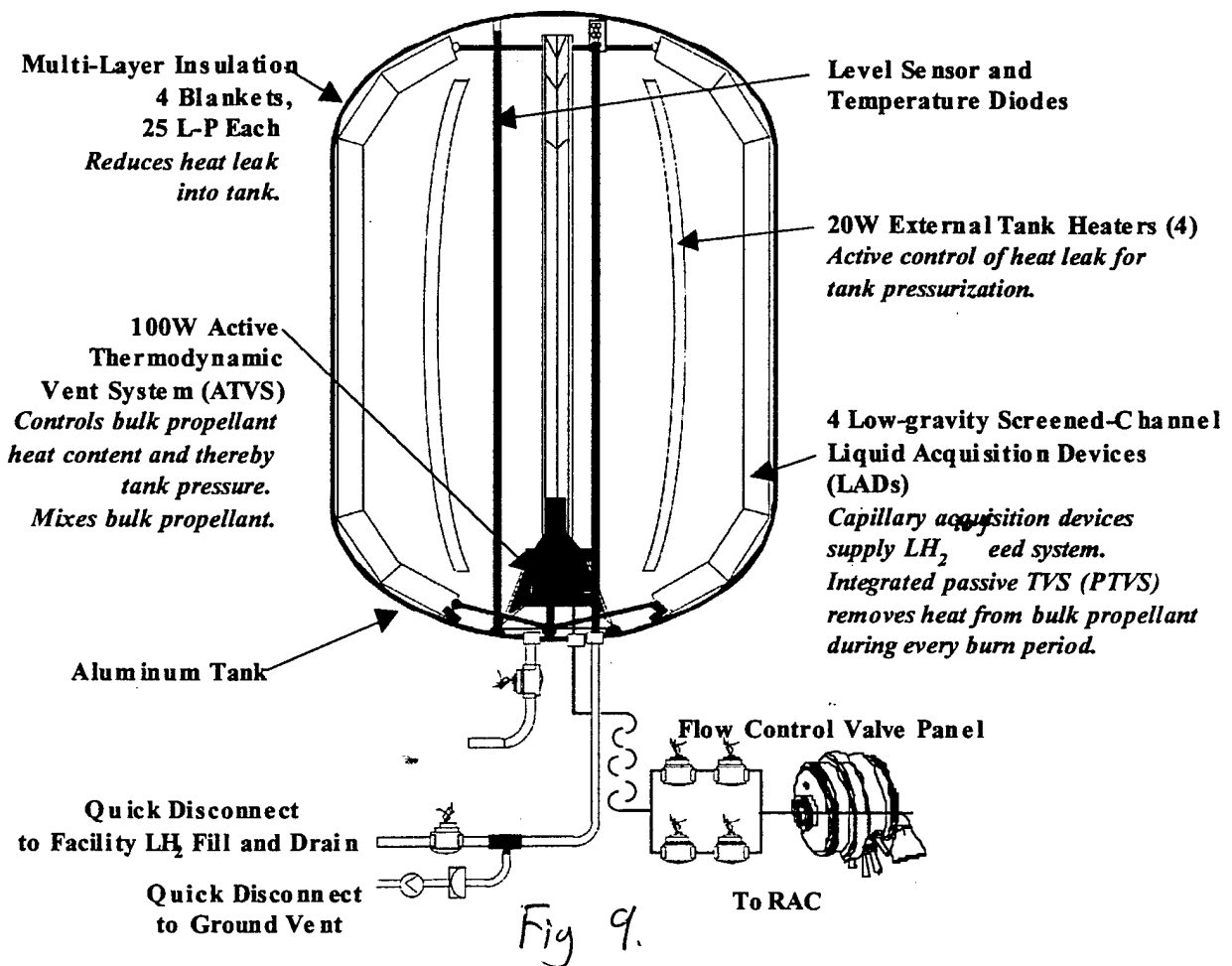

Fig 8  
 8

Figure 34. RAC Subsystem Schematic



**Table 1. SOTV Requirements for Space Experiment and Operational System**

Requirement
Initial Orbit
Perigee

Complete?

# Table 1

tems included either a ~~Standard Small Launch Vehicle (SSLV) Taurus~~ or an Evolved Expendable Launch Vehicle (EELV) Medium Launch Vehicle (MLV). Both launch opportunities were based out of the Cape Canaveral launch site. ~~Mission requirements that were established included~~

**Table 1 SOTV Requirements for Space Experiment and Operational System**

Requirement	Space Experiment			SOTV	
	EELV	Taurus			
Initial Orbit					
Perigee	km	926	926	555	200
Apogee	km	926	926	2350	8000
Inclination	deg	55	55	28	28
Final Orbit					
Perigee	km	926	926	555	35786
Apogee	km	5350	35786	8200	35786
Inclination	deg	55	55	28	0
Mission $\Delta V$	m/s	816	2300	820	3000
Transfer Time	days	21.6	41.2	20.8	30
Specific Impulse	sec	746	340	756	800
Thermionic Power	We	100	100	100	15000
Propellant		H <sub>2</sub>	NH <sub>3</sub>	H <sub>2</sub>	H <sub>2</sub>

initial/staging orbit elements (perigee and apogee altitude and inclination), final orbit elements, total mission  $\Delta V$ , maximum orbit transfer time, maximum space experiment mission time, specific impulse, thermionic power level, and propellant type. These requirements are summarized and compared to similar requirements for an operational SOTV in **Table 2**.

The initial orbit for the EELV was defined by the STP office to be compatible with the other multiple-manifested space experiments designated with the 2001 EELV launch opportunity. The initial orbit for the Taurus launch vehicle was used to derive the initial mass limit for the space experiment. The initial (staging) and final (target) orbits for the SE and operational SOTVs were used to derive the orbit transfer  $\Delta V$ . This mission  $\Delta V$  requirement coupled with the additional requirements (transfer time, specific impulse, thermionic power, and propellant type) were used to derive design requirements for an SOTV in terms of sizing (mass and volume). Selection of a single or set of launch vehicle fairing(s) imposes additional constraints on the stowed configuration of the SOTV.

Parameter	Worst Case Value
Facet Slope Error	1.7 mr
Facet Reflectivity	0.92
Facet Specular Error	1.7 mr
Solar Alignment Error	0.1
Optical Vertex Shift	0.1"
Focal Length Change	0.5"

Table 2

*Is this complete*

Design Trade		
Number of Concentrators Offset or Center Fed Optics		

Table 3

**Table 7. CATS Interfaces with the Spacecraft**

Interface	Specification
Stowed concentrator attachment locations	1 attachment at location where boom attaches to S/C 8 attachments at locations where panels interface with tank
Power from S/C bus	Power for release mechanisms Power for deployment actuators Power for gimbal adjustments Power for sun sensors
Telemetry	Deployment completion indicators Gimbal location potentiometers Sun sensor output Aperture flux gage outputs Key temperature sensors
Pointing and Tracking Control	S/C provides controller to process telemetry and determine gimbal adjustments
S/C Pointing Aperture Size	S/C to point within 1.0° of the sun 2-in. diameter

**4.1.3 Design.** The main functional CATS requirement is to provide 3075 W into the secondary concentrator, which will result in 2460 W net power to the engine during operation. There are several basic architectural design trades, summarized in **Table 8**, which form the basic architecture of the CATS.

<sup>3</sup>  
**Table 8. CATS Subsystem Design Trades**

Design Trade	Considerations	Selection
Number of Concentrators	1 concentrator is much less expensive 2 concentrators provide better dynamic balance	1 Concentrator
Offset or Center Fed Optics	Offset reduces weight, size, simplifies stowed package	Offset Optics
Concentrator Type	Center fed simplifies deployed design Inflatable is lightweight but unproven Spline Radial Panel is lightweight but unproven Hex Panel structure is proven low risk, low cost	Hex Panel Structure
Panel Structure Geometry	Hex panel design is mature, reduces cost, but doesn't package well Rectangular panels cost slightly more but package well	Rectangular Structure
Facet Shape	Triangular facets are a proven design Rectangular facets reduce stowed package and weight	Rectangular
Spacecraft to Boom Attachment	Attaching at focal point is optimum for optical performance Attaching 12-in. from focal point avoids blockage and extreme temperatures	12-in. from Focal Point
Boom to Concentrator Attachment	Attachment at edge reduces boom size Attachment at center reduces gimbal cost, weight	Center Attachment

Table 3