

NAVAL POSTGRADUATE SCHOOL Monterey, California



THESIS

**ANALYSIS OF THE APPLICABILITY OF AIRCRAFT
VULNERABILITY ASSESSMENT AND REDUCTION
TECHNIQUES TO SMALL SURFACE CRAFT**

by

Julia A. Lillis

June 2002

Thesis Advisor:

Charles N. Calvano

Approved for public release; distribution is unlimited.

THIS PAGE INTENTIONALLY LEFT BLANK

REPORT DOCUMENTATION PAGE			<i>Form Approved OMB No. 0704-0188</i>
Public reporting burden for this collection of information is estimated to average 1 hour per response, including the time for reviewing instruction, searching existing data sources, gathering and maintaining the data needed, and completing and reviewing the collection of information. Send comments regarding this burden estimate or any other aspect of this collection of information, including suggestions for reducing this burden, to Washington headquarters Services, Directorate for Information Operations and Reports, 1215 Jefferson Davis Highway, Suite 1204, Arlington, VA 22202-4302, and to the Office of Management and Budget, Paperwork Reduction Project (0704-0188) Washington DC 20503.			
1. AGENCY USE ONLY (Leave blank)	2. REPORT DATE June 2002	3. REPORT TYPE AND DATES COVERED Master's Thesis	
4. TITLE AND SUBTITLE: Analysis of the Applicability of Aircraft Vulnerability Assessment and Reduction Techniques to Small Surface Craft			5. FUNDING NUMBERS
6. AUTHOR(S) Lillis, Julia A.			
7. PERFORMING ORGANIZATION NAME(S) AND ADDRESS(ES) Naval Postgraduate School Monterey, CA 93943-5000			8. PERFORMING ORGANIZATION REPORT NUMBER
9. SPONSORING /MONITORING AGENCY NAME(S) AND ADDRESS(ES)			10. SPONSORING/MONITORING AGENCY REPORT NUMBER
11. SUPPLEMENTARY NOTES The views expressed in this thesis are those of the author and do not reflect the official policy or position of the Department of Defense or the U.S. Government.			
12a. DISTRIBUTION / AVAILABILITY STATEMENT Approved for public release; distribution unlimited.			12b. DISTRIBUTION CODE
13. ABSTRACT (maximum 200 words) The concepts of vulnerability assessment and reduction have long been employed in the design of military aircraft. Aircraft design has many similarities to the design of small surface craft. Both disciplines deal with minimal recoverability and limited space, space that is crucial for critical component redundancy, separation, and many other principles of vulnerability reduction. This report attempts to directly apply established aircraft vulnerability assessment and reduction techniques to small surface craft, in particular, the <i>Cyclone</i> -class Patrol Coastal craft.			
14. SUBJECT TERMS Small Craft – Survivability – Vulnerability – Patrol Craft – Vulnerability Assessment – Vulnerability Reduction			15. NUMBER OF PAGES 78
			16. PRICE CODE
17. SECURITY CLASSIFICATION OF REPORT Unclassified	18. SECURITY CLASSIFICATION OF THIS PAGE Unclassified	19. SECURITY CLASSIFICATION OF ABSTRACT Unclassified	20. LIMITATION OF ABSTRACT UL

THIS PAGE INTENTIONALLY LEFT BLANK

Approved for public release; distribution is unlimited.

**ANALYSIS OF THE APPLICABILITY OF AIRCRAFT VULNERABILITY
ASSESSMENT AND REDUCTION TECHNIQUES TO SMALL SURFACE
CRAFT**

Julia A. Lillis
Ensign, United States Navy
B.S., United States Naval Academy, 2001

Submitted in partial fulfillment of the
requirements for the degree of

MASTER OF SCIENCE IN MECHANICAL ENGINEERING

from the

**NAVAL POSTGRADUATE SCHOOL
June 2002**

Author: Julia A. Lillis

Approved by: Charles N. Calvano
Thesis Advisor

Terry R. McNelley
Chairman, Department of Mechanical Engineering

THIS PAGE INTENTIONALLY LEFT BLANK

ABSTRACT

The concepts of vulnerability assessment and reduction have long been employed in the design of military aircraft. Aircraft design has many similarities to the design of small surface craft. Both disciplines deal with minimal recoverability and limited space, space that is crucial for critical component redundancy, separation, and many other principles of vulnerability reduction. This report attempts to directly apply established aircraft vulnerability assessment and reduction techniques to small surface craft, in particular, the *Cyclone*-class Patrol Coastal craft.

THIS PAGE INTENTIONALLY LEFT BLANK

TABLE OF CONTENTS

I.	INTRODUCTION.....	1
A.	BACKGROUND.....	1
B.	CHANGING ENVIRONMENTS	2
C.	THE FUNDAMENTALS OF AIRCRAFT COMBAT SURVIVABILITY ANALYSIS AND DESIGN, BY ROBERT E. BALL	3
D.	SURVIVABILITY PRINCIPLES	3
II.	VULNERABILITY ASSESSMENT.....	7
A.	WHAT IS A VULNERABILITY ASSESSMENT?	7
B.	VULNERABILITY MEASURES.....	7
C.	GENERAL REQUIREMENTS	8
1.	Kill Level Selection.....	8
2.	Technical and Functional Description of the Craft.....	9
3.	Critical Component Determination.....	9
a.	<i>Flight and Mission Essential Functions</i>	10
b.	<i>System Essential Functions Relationships</i>	10
c.	<i>Failure Mode and Effects Analysis (FMEA)</i>	10
d.	<i>Damage Mode and Effects Analysis</i>	14
e.	<i>Fault Tree Analysis (FTA)</i>	14
f.	<i>Critical Components, Kill Trees and Kill Expressions</i>	15
4.	Threat Selection.....	16
5.	Critical Component Kill Criteria.....	20
a.	<i>The $P_{k/h}$ Function</i>	20
b.	<i>The Area Removal Criterion</i>	21
c.	<i>The Energy Density Criterion</i>	21
d.	<i>The Damage Criteria for Blast</i>	21
III.	COMPUTATION OF THE VULNERABILITY MEASURES.....	23
A.	NONEXPLOSIVE PENETRATORS OR FRAGMENTS	23
1.	Presented Area.....	23
2.	Vulnerable Area	24
3.	Additional Probabilistic Vulnerability Measures.....	26
a.	P_{h/H_i}	26
b.	P_{k/H_i}	27
c.	<i>Probability of Survival</i>	27
4.	Single Hit Vulnerability	28
a.	<i>The Redundant Model</i>	28
b.	<i>The Overlapping Model</i>	30
c.	<i>The Redundant and Overlapping Model</i>	31
5.	Multiple Hit Vulnerability.....	33

	a.	<i>Kill Tree Diagram</i>	35
	b.	<i>State Transition Matrix</i>	38
		<i>Again, this shows that Ball's method is applicable to small craft...</i>	40
B.		INTERNALLY DETONATING WARHEADS	41
	1.	Expanded Area Approach	41
	2.	Point Burst Approach	44
C.		EXTERNALLY DETONATING WARHEADS	45
	1.	Blast	46
	2.	Fragments and Penetrators	47
	3.	Shock	51
D.		VULNERABILITY TO LASERS	52
E.		VULNERABILITY TO UNCONVENTIONAL WEAPONS	52
IV.		VULNERABILITY REDUCTION	53
A.		VULNERABILITY REDUCTION CONCEPTS	53
B.		CYCLONE-CLASS DESIGN FOR REDUCED VULNERABILITY	53
	1.	Propulsion System	54
	a.	<i>Kill Modes</i>	54
	b.	<i>Design Guidance and Vulnerability Reduction Techniques</i>	54
	2.	Electric System	57
	a.	<i>Kill Modes</i>	57
	b.	<i>Design Guidance and Vulnerability Reduction Techniques</i>	57
	3.	Auxiliary System	58
	a.	<i>Kill Modes</i>	58
	b.	<i>Design Guidance and Vulnerability Reduction Techniques</i>	58
	4.	Structural System	58
	a.	<i>Kill Modes</i>	59
	b.	<i>Design Guidance and Vulnerability Reduction Techniques</i>	59
	6.	Crew System	59
	a.	<i>Kill Modes</i>	59
	b.	<i>Design Guidance and Vulnerability Reduction Techniques</i>	59
	7.	Other Systems	60
V.		CONCLUSION	61
		LIST OF REFERENCES	63
		INITIAL DISTRIBUTION LIST	65

LIST OF FIGURES

Figure 1.	Essential Functions and Mission Phases of the <i>Cyclone</i> -Class.....	12
Figure 2.	Essential System-Function Relationships for the <i>Cyclone</i> -Class.....	13
Figure 3.	Critical Component Determination	17
Figure 4.	Kill Tree	18
Figure 5.	Kill Expression (Mobility Kill).....	19
Figure 6.	Approximation of Craft Presented Areas [After Ref. 7]	24
Figure 7.	Inboard Profile of the <i>Cyclone</i> -Class [After Ref. 7]	32
Figure 8.	Second Deck Arrangement of the <i>Cyclone</i> -Class [After Ref. 7]	32
Figure 9.	Interior Arrangement of the Fore and Aft Engine Rooms of the <i>Cyclone</i> - Class [After Ref. 7]	33
Figure 10.	Kill Tree Diagram: First Hit, Nonredundant Model	35
Figure 11.	Kill Tree Diagram: Second Hit, Nonredundant Model	36
Figure 12.	Kill Tree Diagram: First Hit, Redundant Model	36
Figure 13.	Kill Tree Diagram: Second Hit, Redundant Model.....	37
Figure 14.	Kill Tree Diagram: Second Hit, <i>Cyclone</i> -Class Model.....	37
Figure 15.	Expanded Area Approach for <i>Cyclone</i> -Class [From Ref. 7]	43
Figure 16.	Increase of Damage Volume with Weight of Explosive [From Ref. 9].....	46
Figure 17.	Burst Point Approach for the <i>Cyclone</i> -Class	46
Figure 18.	Assumed Encounter between Externally Detonating Warhead and the <i>Cyclone</i> -Class Patrol Craft [After Ref. 2]	48

THIS PAGE INTENTIONALLY LEFT BLANK

LIST OF TABLES

Table 1.	Some Essential Functions of the <i>Cyclone</i> -Class	11
Table 2.	Example FMEA for <i>Cyclone</i> -Class.....	14
Table 3.	A List of the Damage-Caused Failure Modes for the <i>Cyclone</i> -Class [After Ref. 4].....	15
Table 4.	Probabilistic Data for <i>Cyclone</i> -Class	26
Table 5.	Data for State Transition Matrix	39
Table 6.	General State Transition Matrix [<i>T</i>] for Sample Small Craft.....	39
Table 7.	State Transition Matrix [<i>T</i>] for Sample Small Craft	39
Table 8.	Sample Vulnerability Measures for the <i>Cyclone</i> -Class against Internally Detonating Warheads	43
Table 9.	Given Data for Example Computation of $P_{K/D}$ for the <i>Cyclone</i> -Class [After Ref. 2].....	51
Table 10.	Some Techniques for Preventing Fires and Explosions [From Ref. 2].....	55

THIS PAGE INTENTIONALLY LEFT BLANK

I. INTRODUCTION

A. BACKGROUND

Survivability has always been an important characteristic of U.S. Navy ships. In the earliest days of the nation, American sailing frigates were built with unusually sturdy hulls to resist the round-shot of the day's weapons – USS Constitution, “Old Ironsides”, received her nickname for good reason.

During World War II, U.S. Navy ships were subjected to numerous attacks with a wide range of weapons, from gunfire to torpedoes to suicide aircraft. Their success in surviving these threats was varied, but in many cases the ability of the ships to withstand major attacks was quite remarkable. The USS Franklin (CV13) was brought home by her crew after suffering unprecedented levels of damage. The USS Laffey (DD724), displacing only 3200 tons, sustained hits from four bombs and 5 bomb-laden kamikaze planes, while shooting down nine of them. The highly effective survivability design features of these ships combined with the incredible bravery and tenacity of their crews surely saved them. Clearly, survivability features have been designed into U.S. Navy ships for a long time. [Ref. 1]

Some well-tested and well-understood principles for the survivability design of ships have long been employed. The fundamental principles include:

1. Provide redundant installations of vital capabilities (so that the loss of one will not result in complete loss of an important capability).
2. Locate vital installations in sheltered parts of the ship and provide them additional protection.
3. Separate the redundant installations by as much distance as possible (ships with two missile launchers or gun mounts typically have one forward and one aft).
4. Group all of the components necessary for the operation of a single installation close together so that one of the redundant capabilities can be lost, essentially, only by hitting it – it does not depend on the operation of widely-spread supporting components.

Designing for survivability has, however, changed since the World War II era. The threats our ships must defeat are increasingly lethal; they carry larger warheads, operate at greater distances and employ increasing degrees of “smart” operation.

Reaction times are greatly compressed. Our ships, themselves, have evolved, causing our survivability-design approaches to evolve as well. Ships now carry large volumes of relatively light military payloads, rather than smaller volumes of more dense payloads; missiles instead of gun ammunition. The resulting large volumes make it impracticable, in most cases, to fully employ armor.

The four principles referred to earlier remain appropriate and desirable, however, their implementation tends to rely on the fact that a ship provides fairly large amounts of volume and area. This provides the room needed to install redundant systems in the first place, as well as the size needed to permit their separation.

B. CHANGING ENVIRONMENTS

In the Cold War Era, when nuclear weapons were seen as the major threat to the U.S. Navy, the applicability of these time-tested survivability principles was not considered a priority. With a nuclear threat, it was assumed that a ship could not survive a hit, thus, much of survivability design as applied to surface combatants became irrelevant. Today, however, the threat of nuclear weapons is, while still very real, not the most pressing threat. The Navy has shifted its focus toward the littoral areas of the world and potential low intensity conflicts. The more apparent threats are non-nuclear, and are posed by terrorist groups and smaller navies. Non-nuclear threats are threats that a surface combatant can potentially survive, if the ship has adequate survivability for the given posed threat.

The increasing emphasis on the littorals, however, has additional effects. The littorals are inherently dangerous, crowded places. In the littorals, there is an increased likelihood that an adversary can fire weapons from hidden land sites and the possibility exists that any of numerous small vessels can conceal threats. Furthermore, the reaction time one has in littorals is generally much shorter than in open ocean operations. In this kind of environment, employment of high-value, large Fleet units, before an adversary's threat capabilities have been reduced, might be unacceptably risky. The result is an increasing interest in the employment of smaller ships and even vessels of the kind typically referred to as "small craft". However, as discussed above, much of the U.S. Navy's experience with ship survivability has employed principles which, in turn, are dependent to varying degrees on the large size of ships for their success – i.e. separation

of redundant installations. This gives rise to the question, how would survivability design for small craft differ from that for ships? Exploring this question is the central reason for this thesis.

C. THE FUNDAMENTALS OF AIRCRAFT COMBAT SURVIVABILITY ANALYSIS AND DESIGN, BY ROBERT E. BALL

In recent years, a well-developed body of survivability design principles has been created for aircraft. *The Fundamentals of Aircraft Combat Survivability Analysis and Design*, by Robert E. Ball [Ref. 2], is a comprehensive treatment of the fundamentals of survivability engineering and their application to aircraft design. Published by the American Institute of Aeronautics and Astronautics, this text provides the principles of survivability that are accepted and used by the aircraft industry at large. This text offers the basic taxonomy of the aircraft combat survivability discipline, which is being successfully applied to ships. But as interest in smaller ships or small craft increases, and some of the traditional ship survivability design principles become less applicable, it seems sensible to explore the degree to which techniques of survivability design and assessment arising in the aircraft domain are applicable to small craft. With smaller ships and craft, there begins to exist an increasing convergence on “aircraft-like” characteristics. Small craft begin to resemble aircraft in size as they move away from the larger size of ships; the use of aluminum and composites for weight reduction is more ubiquitous in small craft, as in airplanes; and the volumes and areas available in ships are not available in small craft.

In this thesis, then, the applicability of Ball’s aircraft combat survivability methods to small surface craft will be explored. Because the entire content of this thesis is based on the methods laid out in Ball’s text, repeated citation of *The Fundamentals of Aircraft Combat Survivability Analysis and Design* will not be included while using these specific methods. It should simply be noted that all of the methodology in this thesis comes from Ball’s text.

D. SURVIVABILITY PRINCIPLES

Surface ship combat survivability is defined as “the capability of a surface ship to avoid and/or withstand a manmade hostile environment while performing its mission”[Ref. 1]. It has two main components: susceptibility and vulnerability. Susceptibility is defined as “the probability a ship is hit by a damage-causing

mechanism” [Ref. 1]. There are three probabilistic quantities that make up susceptibility. The first is the probability that the threat is active and ready to engage. The second is the probability that the surface ship is detected, identified, and tracked by the threat. The third is the probability that the threat has a successful launch, flight, and impact with the ship. Ship design, tactics, survivability equipment, and onboard weapons systems influence the susceptibility of a given surface ship. Although susceptibility is a critical component of survivability calculations, this thesis will not focus on it. For all discussion and calculations, it will be assumed that the ship is hit. The focus, then, is on the probability that a ship will be killed given that the ship has been hit. This is known as vulnerability. [Ref. 1]

The second component of ship survivability is vulnerability. Vulnerability is defined as “the inability of a ship to withstand the damage caused by the hostile environment” [Ref. 1]. In other words, it is the conditional probability of being killed, given a hit. Vulnerability is primarily determined by the design of the ship, and can be significantly minimized in the design process.

Recoverability, the probability that a ship can recover from damage, is another important component of surface ship survivability. In general, surface ships tend to have significant damage control abilities, and can often recover from a potential kill [Ref. 3]. However, aircraft, as well as small craft, either do not have these capabilities or possess them to a greatly reduced degree. The focus of this study is the applicability of aircraft survivability design methods to small surface craft. Therefore, in this study, it will be assumed that the small craft has no recoverability.

These probabilistic quantities can be combined mathematically. Survivability (P_S) of a craft is calculated using

$$P_S = 1 - [P_H * P_{K/H} * (1 - P_R)],$$

where P_H is the ship’s susceptibility, $P_{K/H}$ is the ship’s vulnerability, and P_R is the probability that the ship will recover [Ref. 3]. Since, as previously stated, one assumption behind this study is that the craft in question has no recoverability, P_R is set to zero. This leaves the following equation for the calculation of survivability

$$P_S = 1 - (P_H * P_{K/H}).$$

This equation comes from the relationships between killability, susceptibility, and vulnerability. Killability is the probability that the ship will be killed. The killability of the ship is calculated using

$$P_K = P_H * P_{K/H}$$

which is simply the product of susceptibility and the vulnerability. The survivability of the ship can be thought of as the opposite of killability, that is, killability plus survivability equals one. Therefore,

$$P_S = 1 - P_K.$$

Due to the nature of ships, a kill does not always imply total destruction and sinking of the ship. There are many levels of kill, each with its own degree of severity. The degrees of kill will be discussed at length in the following chapter. [Ref. 1]

THIS PAGE INTENTIONALLY LEFT BLANK

II. VULNERABILITY ASSESSMENT

A. WHAT IS A VULNERABILITY ASSESSMENT?

A vulnerability assessment is a means of obtaining quantitative values for the measures of vulnerability of the craft under review. Such an assessment can be carried out manually or with the help of a computer vulnerability analysis program. In any case, the vulnerability assessment allows for the comparison of craft based solely on vulnerability.

Ball's method of aircraft vulnerability assessment calls for the assessment to be completed at one of three levels of detail: estimate, evaluation, or analysis. Estimates use only a few major parameters of the craft and only focus on the major damage mechanisms. They use simple equations and the output is a very rough estimate of the vulnerability of the craft. Evaluations are more detailed assessments, using specifics from the aircraft such as critical component sizes and locations, as well as specific damage mechanisms. The output is harder to achieve than that of an estimate, but it can be much more accurate. Analyses are vulnerability assessments carried out to the utmost level of detail. They are usually conducted using complex models of the craft under review. Analyses are, of course, the most accurate vulnerability assessments.

Vulnerability assessments, whether they are carried out by hand or by computer, are accomplished using various vulnerability assessment techniques. Not only are there several types of vulnerability assessment techniques, there are also several different measures of vulnerability that can be calculated for a craft in a hostile environment. Nevertheless, there are general requirements for all assessment techniques and vulnerability measures.

B. VULNERABILITY MEASURES

The vulnerability of a craft depends largely on its environment and the type of threat it is likely to encounter in that environment. This holds true both for aircraft and small craft alike. For example, the vulnerability measure $P_{K/H}$ represents the probability of a kill given a hit. The use of this vulnerability measure would be appropriate when the craft is in a hostile environment in which the threat needs to hit the craft in order to kill it. Another vulnerability measure is the craft's vulnerable area, A_V . This is an area, the

calculation of which will be discussed later, that, if hit, would result in a kill. These are just two examples of a variety of vulnerability measures that can be calculated using vulnerability assessment techniques.

C. GENERAL REQUIREMENTS

Regardless of the type of vulnerability measure or the specific technique used, all techniques have certain general requirements that make them viable options for a vulnerability assessment. Ball's method indicates the following requirements for an aircraft vulnerability assessment. These general requirements are true for aircraft as well as small craft vulnerability assessments; however, the specifics of the elements will differ. The required elements are: (1) kill level selection, (2) technical and functional description of the craft, (3) critical component determination, (4) threat selection, (5) critical component kill criteria, and (6) computation of vulnerability measures.

1. Kill Level Selection

In small craft, as in aircraft, all kills are not equal with respect to vulnerability. Ball uses three kill levels to measure the degree to which an aircraft suffers performance degradation in aircraft vulnerability assessments. These levels are Attrition Kill, Mission Abort Kill, and Forced Landing Kill. There are similar kill levels commonly used when discussing ship survivability. The following kill level definitions are commonly used when discussing ship survivability and they will be used for the entirety of this research effort:

- Total Kill will refer to the ship being totally lost and abandonment occurring. This would most likely be caused by sinking or catastrophic fire.
- A Mobility Kill will refer to loss of mobility and/or loss of controllability.
- A Mission Area Kill will refer to loss the ability to perform a specific ship mission (i.e. SEAL insertion/extraction capabilities).
- A System Kill will refer to any damage that leads to the loss of an entire ship system (i.e. Lighting system). [Ref 1]

Of course, these kill levels are dynamic in nature. For example, with time and poor recoverability and/or damage control efforts, an initial system kill can turn into a mission area kill, which can eventually turn into a mobility kill which can lead to a potential total kill. [Ref. 1]

2. Technical and Functional Description of the Craft

Just as Ball's method indicates, as much information as possible about the craft should be gathered prior to commencement of the vulnerability assessment. The amount of information needed depends on the level of detail to which the assessment is to be completed. In general, this includes technical and functional descriptions. The technical description should include all major systems. Information regarding location, size, material, construction, and operation of systems, subsystems, and components is essential for an accurate assessment. The functional description should describe the functions provided by the systems, subsystems, and components, as well as define functional relationships between them, including redundancies.

This general requirement is much harder to meet for small craft than it is for aircraft. While the major systems in both are similar, there are far more subsystems and many more components in a small craft.

In the example of the Patrol Coastal *Cyclone* Class, many of the technical and functional descriptions were identified, using the PC-1 Class Booklet of General Drawings. This proves that with enough time, it is possible to obtain complete technical and functional descriptions of a small craft.

3. Critical Component Determination

Ball defines a critical component as any component, which, if either damaged or destroyed, would yield a defined or definable kill level. The criticality of a given component is closely tied to functionality. If a component provides an essential function it can be deemed a critical component. If a component does not provide an essential function, yet its failure leads to the failure of a critical component that does provide an essential function, then it too can be deemed a critical component. As indicated by Ball's method, the following steps should be taken to identify the critical components of an aircraft: (a) identify flight and mission essential functions, (b) identify system essential functions relationships, (c) conduct a failure modes and effects analysis (FMEA), (d) conduct a damage mode and effects analysis (DMEA), (e) conduct a fault tree analysis (FTA), and (f) complete a kill tree and/or a kill expression.

a. *Flight and Mission Essential Functions*

Ball's method identifies flight and mission essential functions first in the pursuit of critical components. For a small craft, flight is comparable to stability and mobility. Therefore, the first step in critical component determination for a small craft is identification of stability, mobility, and mission essential functions. Stability essential functions are those system and subsystem functions that allow the small craft to float upright. An example of this is the provision of watertight integrity of the hull by the structural system. Mobility essential functions are those system and subsystem functions that enable the small craft to sustain controlled motion. An example of a mobility essential function is the provision of thrust by the propulsion system. Mission essential functions are those system and subsystem functions that enable the small craft to perform its designated missions. For the *Cyclone*-class patrol craft, an example of a mission essential function is the ability to launch the rigid hull inflatable boat (RIB) so that it may board intercepted traffic. This function is provided by the small boat subsystem.

Table 1 and Figure 1 provide useful information for this step in the vulnerability assessment. Table 1 lists some of the essential functions for the *Cyclone*-class patrol craft. Figure 1 is a chart that can be used to determine which functions are essential for which mission/mission phases. This figure is especially useful for the determination of the most essential functions of the craft.

b. *System Essential Functions Relationships*

The next step in the determination of critical components is to examine the essential system-function relationships. From the previous step, the most essential functions were identified. With this information in hand, a check should be made to determine which systems and subsystems contribute to these essential functions. Figure 2 is a chart that is useful for determining the systems that are necessary for the essential functions of the *Cyclone*-class patrol craft to continue.

c. *Failure Mode and Effects Analysis (FMEA)*

Ball offers the failure mode and effects analysis as a means of identifying all the failure modes of subsystems, and components, as well as determining the effects of these failures on the subsystems and systems of the craft. Table 2 shows sample FMEAs for a number of different components and kill levels.

Table 1. Some Essential Functions of the *Cyclone*-Class

FLOTATION/MOBILITY	MISSION	SUPPORT SERVICES
Provide flotation	Provide communications	Provide electric power
Provide thrust	Provide internal comms	Provide air conditioning
Control mobility	Provide external data links	Provide mess services
Provide speed-making ability	Start systems	Provide head services
	Monitor systems	
	Gather Intelligence	
	Operate sensors	
	Navigate	
	Locate/ID targets	
	Employ weapons	
	Deploy RIB	

Table 2. Example FMEA for *Cyclone*-Class

Generic Failure Modes of a Subsystem	
1	Premature operation
2	Failure to operate
3	Failure to cease operation
4	Out-of-tolerance operation

Component	Location	Failure Mode	Effect on Subsystem	Ship System	Effect of Degraded Subsystem on Ship	Kill Level
Reduction Gears	3-14-0-E and 3-29-0-E	2. Loss of lubrication	Total loss of reduction capabilities	Propulsion	Ship loses mobility	Mobility Kill
Port Rudder	Stern	4. Structural damage from foreign object	Total loss of rudder capabilities	Auxiliary (Steering)	Ship maintains ability to maneuver with the 3 rudders, but it requires much greater effort on part of crew and puts strain on the other rudders	Component Kill that will eventually lead to System Kill
SEALS	3-49-0-E	2. Loss of crew in SEAL prep room	Total loss of SEAL capabilities	Crew, possibly Structural	Ship cannot perform it's SPECWAR OPS mission	Mission Area Kill

d. Damage Mode and Effects Analysis

The damage mode and effects analysis is a means of identifying the damage-caused failure modes of the craft. The DMEA can take many forms, such as a DMEA matrix, a disablement diagram, or simply a list of damage-caused failure modes. Regardless of the form, the DMEA should identify the different kinds of damage-caused failure modes that can occur within each system of the small craft. Table 3 offers a list of system damage-caused failure modes for the Cyclone-class patrol craft.

e. Fault Tree Analysis (FTA)

A fault tree analysis is a means of determining what event or combination of events will result in a specific undesired event. This approach starts with a specific undesired event and, through a series of logic gates, determines all the possible events and combinations of events that will result in the initial undesired event.

Table 3. A List of the Damage-Caused Failure Modes for the *Cyclone*-Class [After Ref. 4]

TOTAL KILL	MOBILITY KILL	MISSION KILL
<u>Structural System</u>	<u>Electrical Power</u>	<u>Crew</u>
Structural removal	Severing or grounding	Loss of crew (death or injury)
Pressure overload	Mechanical failure	
Thermal weakening	Overheating	<u>Auxiliary Equipment</u>
Penetration		Loss of small boat system
Fire/flooding	<u>Electronic Equipment</u>	
WT bulkhead damage	Loss of control power	<u>Electronic Equipment</u>
	Loss of antennas, etc.	Loss of control power
<u>Combat System</u>		Loss of antennas, etc.
Fire	<u>Auxiliary Equipment</u>	
Explosion	Loss of monitoring systems	<u>Combat System</u>
	Loss of piping system	Fire
	Fuel supply depletion	Explosion
	In-tank fire/explosion	Loss of weapon capabilities
	Void space fire/explosion	Depletion of armament
	Sustained exterior fire	
	Damage to rudder	
	<u>Propulsion System</u>	
	Foreign object ingestion	
	Inlet flow distortion	
	Lubrication oil depletion	
	Exhaust duct failure	
	Engine control and accessories failure	
	Failure of shaft, gearbox, bearings, etc.	

f. Critical Components, Kill Trees and Kill Expressions

The previous steps should provide enough information to accurately determine the critical components of the craft. As stated before, a critical component is any component, which, if either damaged or destroyed, would yield a defined or definable kill level [Ref 1]. One final comparison that Ball never explicitly makes can be helpful in this determination. This comparison can be seen in Figure 3. This figure shows a breakdown of the ship systems into subsystems can components. It compares these subsystems and components to the mission phases. Furthermore, the degree to which a component or subsystem is critical to a mission phase can also be indicated. The degrees are: (3) Component is ABSOLUTELY NECESSARY for completion of this

mission phase, (2) Component is ALWAYS USED, BUT POTENTIALLY NOT NECESSARY for completion of this mission phase, and (1) Component is HELPFUL for completion of this mission phase. Summation across the row for each component or subsystem provides a numerical means of comparing the criticality of components and subsystems. Obviously the Component/Subsystem column can be further broken-down into greater detail.

Once the critical components have been identified, it is often useful to create a kill tree. A kill tree is a visual representation of the critical components. Kill trees are a convenient means of illustrating the redundancy or non-redundancy of critical components. Figure 4 shows a kill tree for the *Cyclone*-Class patrol craft.

The kill expression is a logical statement that describes the kill tree in words. This statement will therefore indicate critical component redundancy. Figure 5 shows a kill statement that corresponds to the kill tree in Figure 4.

4. Threat Selection

After determining the critical components of the craft, a selection of the specific threats that it might encounter should be made. A vulnerability assessment is usually done considering either a specific threat or a specific damage mechanism.

The specific threats that a small craft might encounter are not entirely the same as those encountered by an aircraft. In Ball's method, threats have been grouped into general categories of damage mechanisms. These threat categories are: (a) a nonexplosive penetrating projectile or fragment, (b) the fragments and blast from internally detonating warheads, (c) external blast, (d) the fragments, penetrators, and missile debris from externally detonating warheads, and (e) the laser. A small craft may encounter all of these threats, so they should all be looked at in the examination of the *Cyclone*-class patrol craft. However, small craft should also consider the threat of nuclear weapons as well as chemical, biological, and radioactive weapons. Another aspect of threat selection that should be addressed is the air-water interface, which adds more complexity to the threat selection for a surface craft. The same threat can have very different effects on a surface ship depending on if it hits above, below, or at the waterline.

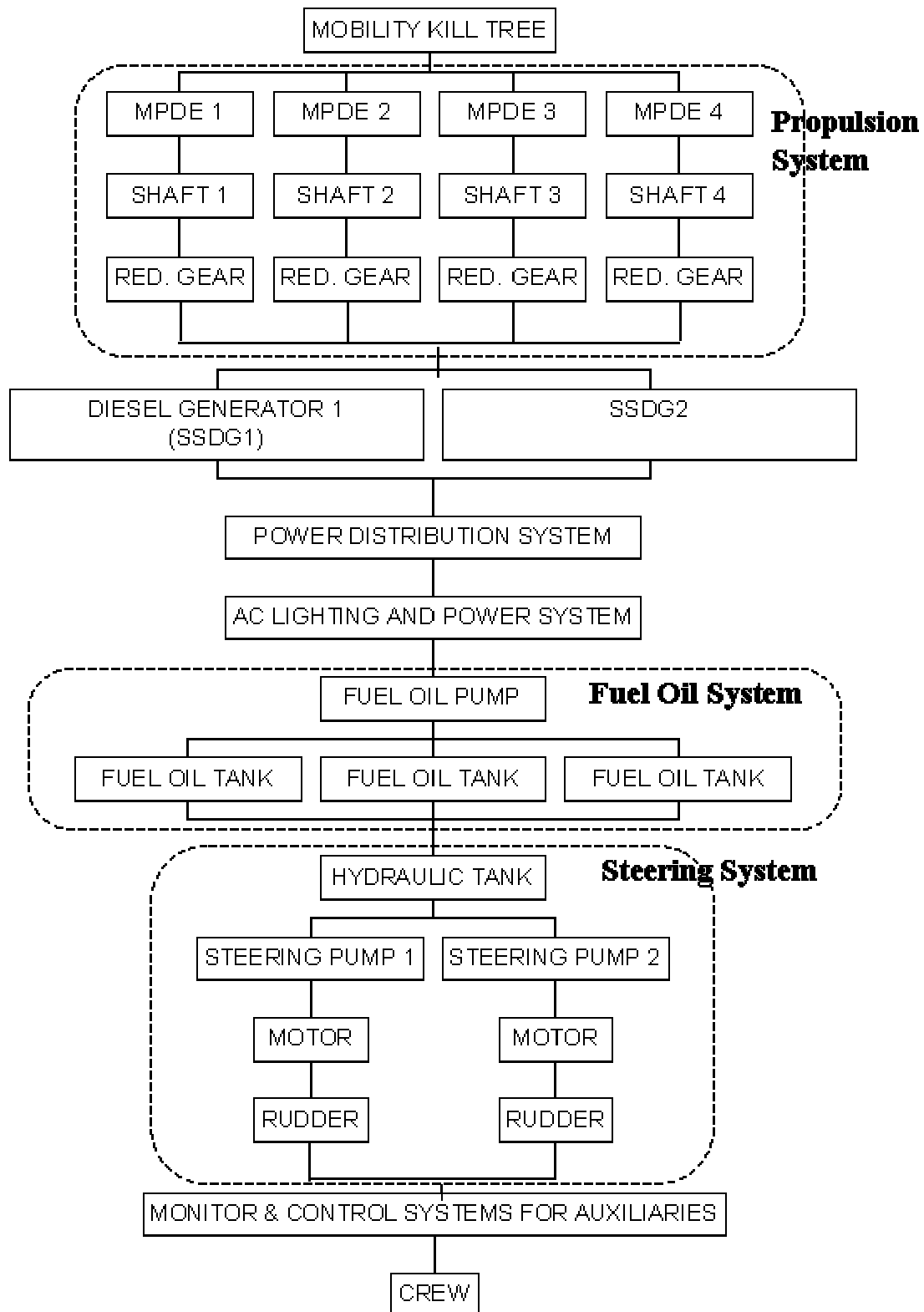

Figure 4. Kill Tree

[(MPDE1 OR Shaft 1 .OR. Reduction Gear 1) .AND. (MPDE2 .OR. Shaft 2 .OR. Reduction Gear 2) .AND. (MPDE3 OR Shaft 3 .OR. Reduction Gear 3) .AND. (MPDE4 .OR. Shaft 4 .OR. Reduction Gear 4)] .OR. [Diesel Generator 1 .AND. Diesel Generator 2] .OR. Power Distribution System .OR. AC Lighting/Power System .OR. Fuel Pump .OR. [Fuel Oil Tank 1 .AND. Fuel Oil Tank 2 .AND. Fuel Oil Tank 3] .OR. Hydraulic Tank .OR. [(Steering Pump 1 .OR. Motor 1) .AND. (Steering Pump 2 .OR. Motor 2)] .OR. [Rudder 1 .AND. Rudder 2] .OR. Monitor & Control Systems for Auxiliaries .OR. Crew

Figure 5. Kill Expression (Mobility Kill)

For the example of the *Cyclone*-class patrol craft, all of the above threats are potential threats for which a vulnerability assessment could be made. To determine the most applicable threats, an examination of the missions and working environment must be made. The primary mission of most small craft is coastal patrol and interdiction (CP&I). In this mission, patrol craft regulate maritime shipping traffic; conduct inspections of shipping traffic; interdict drug runners, pirate, smugglers, and illegal immigrants [Ref 5]. The likely threats to be encountered during this mission are small arms carried by drug runners, pirates, smugglers, and illegal immigrants. Small arms fall into the category of nonexplosive penetrating projectiles or fragments. [Ref. 5]

In continuation of the specific example of the *Cyclone*-class patrol craft, the current primary mission is homeland defense and port security. This mission involves many of the same duties as CP&I. Along with those duties, it also includes the interception of suspicious ships prior to port entrance, the provision of anti-terrorism protection for Navy ships, the escorting of commercial ships in and out of U.S. ports, and the deployment of U.S. Coast Guard law enforcement teams [Ref. 6]. The likely threats to be encountered in this mission include those listed above, as well as the potential threat of terrorists. The terrorist threats to be considered are small arms, bombs, suicide bombers, as well as unconventional weapons. This means that a comprehensive vulnerability assessment of the *Cyclone*-class patrol craft would include assessments of the ship's vulnerability with respect to nonexplosive penetrators or fragments, internally detonating warheads, externally detonating warheads, and possibly nuclear, chemical, biological, radioactive and threats.

5. Critical Component Kill Criteria

After determining the critical components and selecting the threat to be assessed, the damage criteria for each of the failure modes of the critical components must be evaluated with respect to the specific threat that has been selected. The goal of this step is to determine what criteria must be met for each critical component to be killed in each of its failure modes for each threat selected. Ball uses four specific kill criteria in assessing aircraft critical component kill criteria. They are (a) the $P_{k/h}$ function, (b) the area removal criterion, (c) the energy density criterion, and (d) the damage criteria for blast.

a. *The $P_{k/h}$ Function*

Determination of the probability of a component kill given a hit is one method of determining the criteria for a component kill. For this criterion, Ball defines a hit as impact by a fragment or penetrator. The $P_{k/h}$ function is usually used for single fragment vulnerable components; meaning those components that can be killed by a single hit. It is a function of the many things, including but not limited to, the mass and velocity of the fragment or penetrator.

Ball's method indicates that values for $P_{k/h}$ are generally obtained through a separate engineering analysis done for each critical component. Each critical component is examined, and the effects of a hit by a specific threat are estimated. The mass, striking velocity, obliquity, and shape of a penetrator or fragment must also be accounted for. A numerical value for $P_{k/h}$ is then assigned to each component based somewhat on experimental data, but mostly on experience and engineering intuition.

Location within the craft plays a part in estimating the $P_{k/h}$ value for a given component. Since this criterion depends heavily on striking velocity and is influenced by obliquity of the penetrator or fragment, a component that is shielded by a number of other components will have a lower $P_{k/h}$ value than a component with no shielding. This plays a greater role in the assessment of small craft than for an aircraft since a small craft has more potential shields, because it has more components. This is good from a vulnerability reduction standpoint, since it offers designers many non-critical

components with which to shield a critical component. Vulnerability reduction will be discussed in depth in the next chapter.

b. The Area Removal Criterion

Ball's second method for determining the criteria for a component kill is the area removal method. For each critical component, a particular amount of area is specified. This area represents the amount of area that, if removed by a hit from a penetrator, would result in a component kill. This method is applicable to any damage mechanism that is capable of removing a given amount of area. Usually, it is applied when the threat is a large penetrator or many small penetrators or fragments. In general, this method is used in aircraft for structural components. In small craft, this method could be extremely useful for watertight bulkheads or other critical components in the structural system whose performance might be severely degraded with significant area removal.

c. The Energy Density Criterion

Another type of critical component kill criterion that Ball offers is the energy density criterion. In this method, like the area removal criterion, a particular amount of area is specified for each critical component. In this method, however, that area represents the minimum surface area that must be exposed to a threshold level of the kinetic energy density of the impacting damage mechanism. Ball's method prescribes the energy density criterion to any large aircraft components, such as structural components, fuel tanks, and propulsion components. In small craft, it could be applied to these same types of large components.

d. The Damage Criteria for Blast

The damage criteria for blast, as stipulated by Ball's method for aircraft, are the critical values for pressure and impulse on the surface of an aircraft necessary to kill a given component. For surface ships, it is necessary to also consider shock, which is simply an underwater blast. For small craft, it is important to consider the critical values, or thresholds, of pressure and impulse for all critical components with respect to blast and shock [Ref 3]. This is one instance in which Ball's aircraft method is not adequate for a small craft vulnerability assessment.

THIS PAGE INTENTIONALLY LEFT BLANK

III. COMPUTATION OF THE VULNERABILITY MEASURES

A. NONEXPLOSIVE PENETRATORS OR FRAGMENTS

Nonexplosive penetrators or fragments are the first category of damage mechanisms to be evaluated. Ball's method indicates that the vulnerability of a craft with respect to this threat selection is usually given as the total vulnerable area, A_V , or as the probability of a craft kill given a random hit on the craft, $P_{K/H}$. Both of these measures are also applicable to the individual critical components of the craft. The vulnerable area of the i^{th} critical component is denoted by A_{v_i} . The probability of killing the i^{th} critical component, given a hit on the i^{th} critical component is denoted by P_{k/h_i} . This is not to be confused with the probability of killing the i^{th} critical component given a random hit on the craft, which is denoted by P_{k/H_i} . The process of determining the $P_{K/H}$ function was discussed earlier. The process of calculating the vulnerable area will now be addressed.

1. Presented Area

The first thing that needs to be determined for these calculations to be made is the presented area of the craft or component in the plane normal to the approach of the damage mechanism. The presented area of the ship and the presented area of the i^{th} critical component of the ship are denoted by A_P and A_{p_i} , respectively. For the example of the *Cyclone*-class patrol craft versus the threat of nonexplosive penetrators or fragments, one presented area is the ship profile above the waterline. Obviously there are other potential approaches a damage mechanism could take, this is merely an example of the most likely aspect that the mechanism will see. This particular presented area does not include the presented area of the hull that extends below the waterline. This is because a nonexplosive penetrator, like small arms, would be extremely unlikely to approach the craft below the surface of the water. [Ref. 4]

For the *Cyclone*-class, the presented area of the ship is approximately 2820 ft². The presented area of individual critical components would be calculated only for those components located above the waterline. For comparison purposes, the presented profile area of a large military aircraft, such as the P-3 Orion is approximately 700 ft². A sleeker

fighter aircraft, such as the F-14 Tomcat has a presented profile area of approximately 300 ft². Figure 6 shows how these approximations were made.

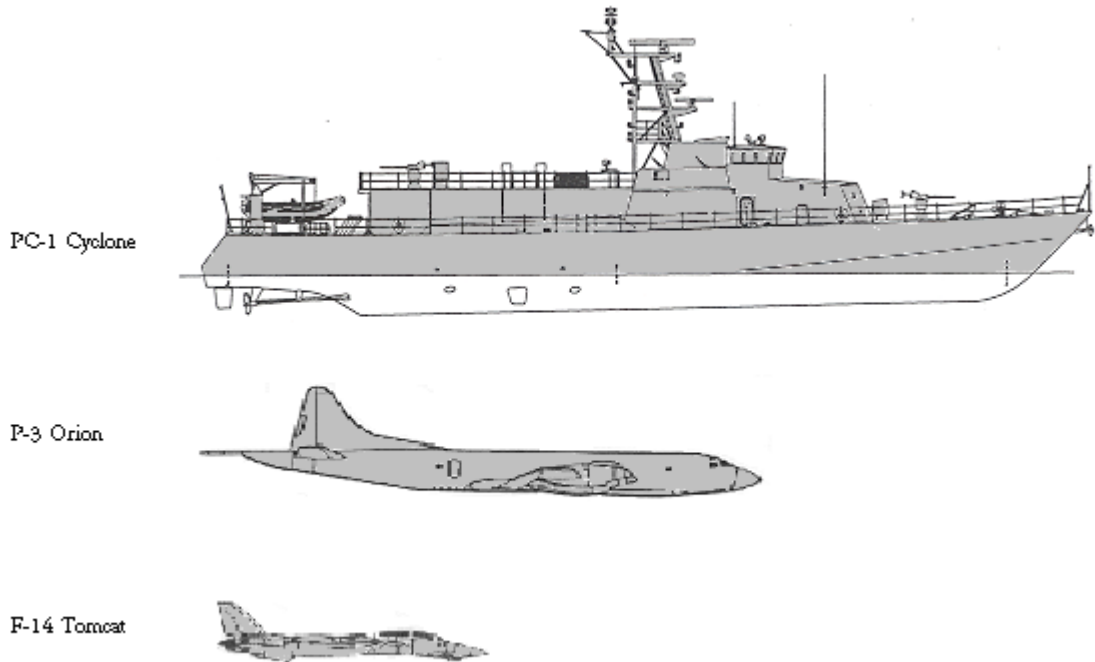

Figure 6. Approximation of Craft Presented Areas [After Ref. 7]

2. Vulnerable Area

The vulnerable area is a measure the degree of vulnerability of a craft or component. For a craft, the vulnerable area is given by the following equation

$$A_V = A_P P_{K/H} .$$

It is the product of the presented area and the probability of a kill given a hit. The latter of these is very difficult to define for a craft. The probability of a craft kill given a random hit on the craft depends on many things. To come up with a useful measurement, the vulnerable area of individual critical components is often calculated. The summation of the vulnerable areas of all the critical components on a craft equals the vulnerable area of the craft itself. The vulnerable area of a critical component is equal to the product of that component's presented area and the P_{k/h_i} value for the component. Ball's method uses the following equation to calculate the vulnerable area of the i^{th} critical component

$$A_{v_i} = A_{p_i} P_{k/h_i} .$$

Then, for N critical components, the equation for the vulnerable area of the entire craft is given by

$$A_V = \sum_i^N A_{v_i} .$$

The $P_{K/H}$ value for the entire ship can then be estimated using the following equation

$$P_{K/H} = \frac{A_V}{A_P} .$$

For the example of the *Cyclone*-class patrol craft, one of the critical components that could be damaged by a nonexplosive penetrator or fragment (i.e. a component above the waterline) is the number one ship service diesel generator. There are actually two diesel generators on the *Cyclone*-class, which makes it a redundant component. Redundancy will be discussed in detail in a following section. For the following calculations redundancy will not be addressed. The presented area of the diesel generator from the profile view is approximately $A_{p_{SSDG1}} = 33 \text{ ft}^2$. For example purposes, the P_{k/h_i} value for the diesel generator, with respect to the particular threat of a single nonexplosive penetrator, can be estimated to be $P_{k/h_{SSDG1}} = 0.2$. This means that, given that a nonexplosive penetrator or fragment hits the diesel generator, it has a 20% chance of being killed. The vulnerable area of the diesel generator, in this particular scenario is then calculated as follows

$$A_{v_{SSDG1}} = (33 \text{ ft}^2) \times (0.2) = 6.6 \text{ ft}^2 .$$

As another example, the following components of the *Cyclone* will be considered critical components as an example: four main propulsion diesel engines (MPDE), four main propulsion shafts (MPS), and two ship system diesel generators (SSDG). The Table 4 shows the probabilistic data. The values for A_{p_i} were obtained from simple component geometry for the profile view of all components. These values for A_{p_i} represent the individual component presented areas. All four of the critical components listed in Table 4 are redundant components. Furthermore, the main engines and the shafts overlap other

components. Since the concepts of overlap and redundancy have not yet been explored, the total presented area will simply be the summation of the individual presented areas of two main propulsion engines, one forward shaft, one aft shaft, and two diesel generators. This will sum to be the total area of critical components that is presented to a damage mechanism approaching from abreast. The values for the P_{k/h_i} functions are sample values that should not be taken literally. For actual values, separate engineering analyses must be performed on each critical component. Furthermore, as previously stated, there are many factors that affect the P_{k/h_i} function, none of which have been defined for this example.

Table 4. Probabilistic Data for *Cyclone*-Class

Critical Component	A_{p_i} (ft ²)	* P_{k/h_i}	= A_{v_i} (ft ²)	$P_{k/H_i} = A_{v_i}/A_P$
Main Propulsion Engine	77.0	0.1	7.7 (x2)	0.00546
Fwd Main Propulsion Shaft	20.7	0.25	5.2 (x1)	0.00184
Aft Main Propulsion Shaft	11.1	0.25	2.8 (x1)	0.00098
Diesel Generator	33.0	0.2	6.6 (x2)	0.00468
For the entire craft...	$A_P = 2820$		$A_V = 36.6$	$P_{K/H} = 0.01296$

3. Additional Probabilistic Vulnerability Measures

The vulnerable area is one measure of vulnerability of a critical component. There are a few probabilistic values that are also important in both aircraft and small craft vulnerability assessments.

a. P_{h/H_i}

Since it is not known where a nonexplosive penetrator or fragment will penetrate the craft, a useful value to calculate is the probability that a component is hit given a random hit on the craft. This value indicates the likelihood of a component hit. It is the ratio of the presented area of the component to the presented area of the craft. It is given by the following equation

$$P_{h/H_i} = \frac{A_{p_i}}{A_p}.$$

For the example of the *Cyclone*-class patrol craft, this equation can be used directly. Continuing the example of the diesel generator, the probability of the diesel generator being hit, given that there is a random hit on the ship is calculated as follows

$$P_{h/H_{SSDG1}} = \frac{(33 \text{ ft}^2)}{(2820 \text{ ft}^2)} = 0.01170.$$

b. P_{k/H_i}

The probability of a component kill given a random hit on the craft is one of the more important values for vulnerability assessment. Ball offers the following equation to calculate this value

$$P_{k/H_i} = P_{h/H_i} P_{k/h_i}.$$

This measure also lends itself directly to the assessment of small craft vulnerability. For the *Cyclone*-class small craft, the probability that the diesel generator will be killed, given a random hit on this ship for a nonredundant case is calculated as follows

$$P_{k/H_{SSDG1}} = (0.0117) \times (0.2) = 0.00234.$$

The above equations can be further manipulated such that

$$P_{k/H_i} = \frac{A_{v_i}}{A_p}.$$

This produces the same result for the probability that the diesel generator is killed given a random hit on the *Cyclone*-class patrol craft

$$P_{k/H_{SSDG1}} = \frac{(6.6 \text{ ft}^2)}{(2820 \text{ ft}^2)} = 0.00234.$$

c. *Probability of Survival*

The probability of killing a craft or one of its components plus the probability of survival of that craft or component is unity. From this relationship, Ball

gives the following equations. The first equation states the probability of the survival of the craft, given a random hit on the craft. The second equation states the probability of survival of the i^{th} component of the craft, given a random hit on the craft:

$$P_{S/H} = 1 - P_{K/H}$$

$$P_{S/H_i} = 1 - P_{k/H_i}$$

Again, these survivability equations can be directly applied to small craft. The survivability of the diesel generator given a random hit on the *Cyclone*-class patrol craft is calculated as follows

$$P_{S/H_{SSDG1}} = 1 - (0.00234) = 0.9977.$$

4. Single Hit Vulnerability

Ball's treatment of vulnerability versus nonexplosive penetrators or fragments is broken-down into two categories: single hit vulnerability and multiple hit vulnerability. Single hit vulnerability assumes only one penetrator. Both redundant and nonredundant models of craft are considered in this method. Furthermore, consideration is given to the overlap of redundant and nonredundant critical components.

Ball addresses the following four models separately in his analysis of single hit vulnerability towards nonexplosive penetrators or fragments: nonredundant model with no component overlap, nonredundant model with component overlap, redundant model with no component overlap, and redundant model with component overlap. Most small craft have some degree of redundancy and overlap among critical components. For this reason, only the final of Ball's categories will be examined in this vulnerability assessment.

a. *The Redundant Model*

Redundancy is a vulnerability reduction technique that will be discussed in length in the next chapter. In short, when a critical component is labeled as being redundant, identical or similar components duplicate some or all of its essential functions. A nonredundant critical component is the only component on the craft that performs a particular essential function. Nonredundancy can increase the degree of criticality of a critical component, since the loss of a nonredundant critical component means complete loss of a particular essential function of the ship, hence a kill on some level.

The kill expression for a redundant craft uses logical AND statements. It is given in the form

$$Kill = (Rc1).AND.(Rc2).AND.\dots.AND.(RcN)$$

where $Rc1$ refers to the kill of redundant component 1 and there are N redundant components. In order for the craft to be killed, it must lose an essential function. In the case of strictly redundant critical components, an essential function is only lost when all the redundant components that can provide that function are killed.

Another model includes both redundant and nonredundant critical components. The kill expression for this model uses logical AND and OR statements. It is given in the form

$$Kill = (Nrc1).OR.(Nrc2).OR.\dots.OR.(NrcM).AND.(Rc1).AND.(Rc2).AND.\dots.AND.(RcN)$$

where $Nrc1$ refers to the kill of the nonredundant component 1, there are M nonredundant components, $Rc1$ refers to the redundant component 1, and there are N redundant components. The probability of craft survival given a random hit on this model is given by Ball as either of the following equations

$$P_{S/H} = \prod_{i=1}^M P_{s/H_i} (1 - \prod_{j=1}^N P_{k/H_j})$$

or

$$P_{S/H} = \prod_{i=1}^M (1 - P_{k/H_i}) (1 - \prod_{j=1}^N P_{k/H_j}).$$

It is also worth noting that for these models, since only a single penetrator is being considered, component kills are mutually exclusive. That is, once one component has been killed, no other components will be killed.

The example small craft, the *Cyclone*-class patrol class, has both redundant and nonredundant critical components, so this model should be employed. However, it also has overlapping critical components, a topic that must be addressed before an assessment of the *Cyclone* can take place.

b. The Overlapping Model

Creating overlap amongst critical components is a means of decreasing the total presented area of the components. Overlap depends on aspect, since some components may overlap from one aspect, but not another. For example, if one critical component is directly above another they overlap if a threat mechanism penetrates from directly above or below the craft, but they do not overlap if the penetrator comes from either side of the craft. This model assumes that any hit on the craft takes place along a shotline that passes completely through the craft, regardless of how many critical components are overlapped along that shotline. This means that, in this model, component kills are not mutually exclusive. This is not always the most appropriate model, since in some cases components will undoubtedly shield other components that they overlap, but Ball's approach offers a conservative method.

The layout of the craft, and the aspect from which the damage mechanism approaches, determine the overlap region, O . For the craft to survive a hit on a shotline passing through region O that consists of C overlapping critical components, each of the C components must survive. Therefore, the probability of survival of the craft, given the overlap region is hit is given by

$$P_{s/h_o} = P_{s/h_1} P_{s/h_2} \cdots P_{s/h_C} = \prod_{i=1}^C (1 - P_{k/h_i}).$$

The overlap region can be thought of as a separate component, with unique presented area, $P_{k/h}$ value, and vulnerable area. The presented area, A_{p_o} , is simply calculated based on the geometry of the overlapping components. The value of the probability of a kill of the component given a hit on the component is calculated as follows

$$P_{k/h_o} = 1 - P_{s/h_o}.$$

The vulnerable area of this region is then given by

$$A_{v_o} = A_{p_o} P_{k/h_o}.$$

c. The Redundant and Overlapping Model

As stated previously, most small craft have some degree of critical component redundancy and overlap. When dealing with overlapping redundant critical components, the overlap region can again be treated as its own component. The equation for the probability that the craft survives, given the overlap region is hit is given by Ball as

$$P_{s/h_o} = \prod_{i=1}^M P_{s_i} (1 - \prod_{j=1}^N P_{k/h_j})$$

where there are M nonredundant components and N redundant components. It can be seen from this equation that, in order for the craft to survive, all the nonredundant components must survive individually and not all of the redundant components can be killed. The probability that not all of the redundant components are killed is given by the complement of $\prod_{j=1}^N P_{k/h_j}$.

The area outside of the overlap region, where redundant critical components no longer overlap, is not used for vulnerable area calculations. The reason for this is that if a single shotline passes through this nonoverlapping region, only one of a set of redundant critical components is killed. This leaves at least one other critical component to provide the essential function of the killed component.

The *Cyclone*-class patrol craft has several critical components that fit into the redundant and overlapping model. This model, however, only accounts for single hits. Single hit vulnerability can easily be lessened with the application of separation, which will be discussed at length in a later section. The design of the *Cyclone* is a good example of the use of separation. So good, in fact, that it is difficult to calculate the single hit vulnerability of the *Cyclone* to offer as an example. Most of the critical components on the *Cyclone* are redundant and separated. This can be observed in Figures 7, 8 and 9. Once redundant components are separated, it is impossible to kill the function that they provide with a single hit. For example, one critical component is the main propulsion diesel engine. There are four main engines onboard the *Cyclone*, making it a redundant component, and they overlap in the profile view. The number one and number four main propulsion diesel engines (MPDE1 and MPDE4) overlap

completely and are located in the forward engine room, while the number 2 and number 3 main propulsion diesel engines (MPDE2 and MPDE3) also overlap completely and are located in the aft engine room. If a single hit was located in the overlap region of MPDE1 and MPDE4 in the forward engine room, only two of the four engines could potentially be killed, leaving MPDE2 and MPDE3 to continue providing propulsion for the small craft. Because nearly all of the critical components of the *Cyclone* are set up in this manner, the single hit vulnerability of this craft is zero. The craft cannot be killed with a single hit of a nonexplosive penetrator. The following figures clearly show the complete overlap and the separation of the main engines.

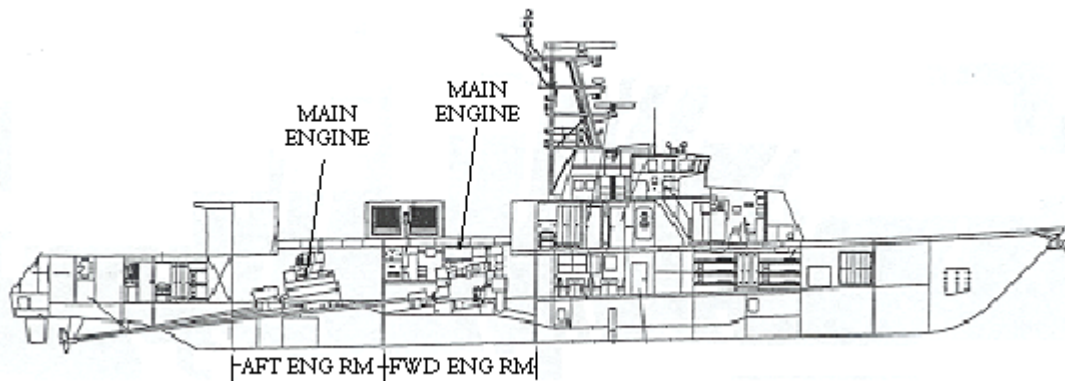

Figure 7. Inboard Profile of the *Cyclone*-Class [After Ref. 7]

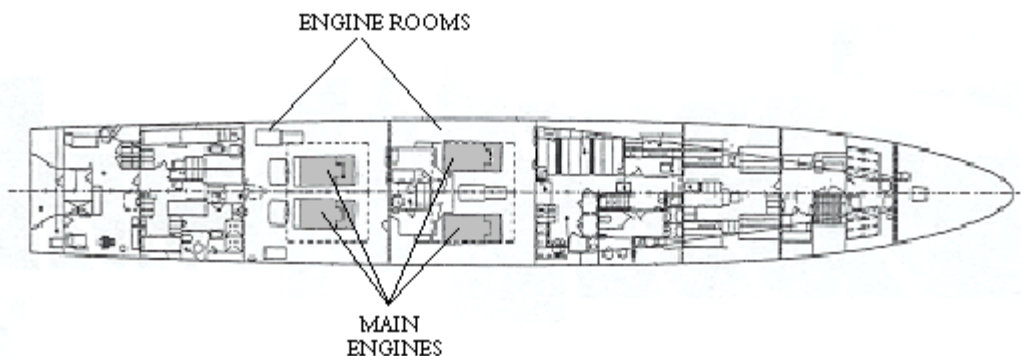

Figure 8. Second Deck Arrangement of the *Cyclone*-Class [After Ref. 7]

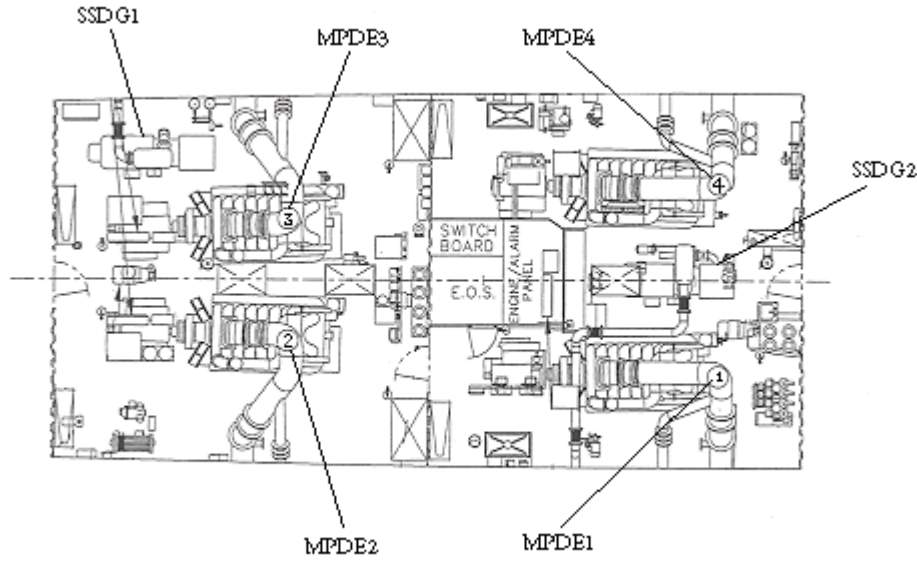

Figure 9. Interior Arrangement of the Fore and Aft Engine Rooms of the *Cyclone*-Class [After Ref. 7]

5. Multiple Hit Vulnerability

Single hit vulnerability measurements are useful for theoretical scenarios; however, multiple hit vulnerability measures are used to model true combat situations. In Ball's method, it is assumed that if a craft is hit, it will receive multiple hits. Ball also assumes that these hits have a random distribution over the craft, and all hits are produced by damage mechanisms that travel along parallel shotlines from the same direction. Ball offers the following equation for the probability of the survival of the i^{th} critical component after n random hits on the craft

$$\bar{P}_{s/H_i}^{(n)} = P_{s/H_i}^{(1)} P_{s/H_i}^{(2)} \dots P_{s/H_i}^{(n)} = \prod_{j=1}^n P_{s/H_i}^{(j)} .$$

where $\bar{P}_{s/H_i}^{(j)}$ is the probability the i^{th} component survives the j^{th} hit on the craft. This is the complement of the probability that the i^{th} component is killed by the j^{th} hit. Accordingly,

$$P_{s/H_i}^{(j)} = 1 - P_{k/H_i}^{(j)} .$$

These equations can be used directly in the small craft vulnerability assessment. The example of the *Cyclone*-class patrol craft can be continued here, again with the critical component of the number one ship service diesel generator (once more without consideration given to its redundancy). For this example, it will be assumed that the *Cyclone* receives 5 hits. The probability the diesel generator survives after 5 hits on the *Cyclone* is given by

$$\bar{P}_{s/H_{SSDG1}}^{(5)} = \prod_{j=1}^5 P_{s/H_{SSDG1}}^{(j)}$$

where

$$P_{s/H_{SSDG1}}^{(j)} = 1 - P_{k/H_{SSDG1}}^{(j)} .$$

The probability that a component is killed given a random hit on the craft is a function of the probability of the component being hit given a random hit on the craft, and the probability of the component being killed given a hit on the component. Neither of these measures of vulnerability varies with the number of hits on the craft. Because of this, the previous equations can be simplified as follows

$$\bar{P}_{s/H_i}^{(n)} = \prod_{j=1}^n (1 - P_{k/H_i}^{(j)}) = (1 - P_{k/H_i})^n .$$

For the *Cyclone* example

$$\bar{P}_{s/H_{SSDG1}}^{(5)} = (1 - (0.00234))^5 = 0.9884$$

Since probability that the generator survives a single hit was already calculated to be 0.9977, this clearly shows that the survivability of the diesel generator decreases as the number of hits increases.

In the case of redundant components, these calculations become more complex because the vulnerable areas of components and the probability of a ship kill given a random hit change with subsequent hits. Ball offers four methods that model the effects of multiple hits: (a) the kill tree diagram, (b) the state transition matrix, (c) the simplified approach for $\bar{P}_{K/H}^{(n)}$, and (d) multiple hit vulnerable area.

a. Kill Tree Diagram

Kill tree diagrams can be created for both nonredundant and redundant models. A kill tree is relatively self-explanatory for the nonredundant model. Figure 10 defines the mutually exclusive kill probabilities of each of the nonredundant components and the probability that no critical components are killed after the first hit on the craft. Note that the summation of these quantities is unity. This diagram accounts for all possibilities of the effect of the first hit. The second hit adds more possibilities, as is shown in Figure 11. These are nonredundant models so they will not be applied to the Cyclone. Figures 12 and 13 define the kill probabilities for the first and second hit, respectively, for a redundant craft. “KILL” indicates that the hit or series of hits for that “branch” of the tree results in a craft kill.

This method can be directly applied to the *Cyclone*-class with the construction of a kill tree diagram that encompasses all of the redundant and nonredundant critical components in the craft. However, a more simplified approach will still prove that the method can be applied to small craft. This type of approach is offered in Figure 14. This kill tree diagram uses only the pair of ship’s service diesel engines as examples of redundant critical components. The example used the probability of an SSDG kill given earlier by

$$P_{k/H_{SSDG}} = \frac{(6.6 \text{ ft}^2)}{(2820 \text{ ft}^2)} = 0.00234$$

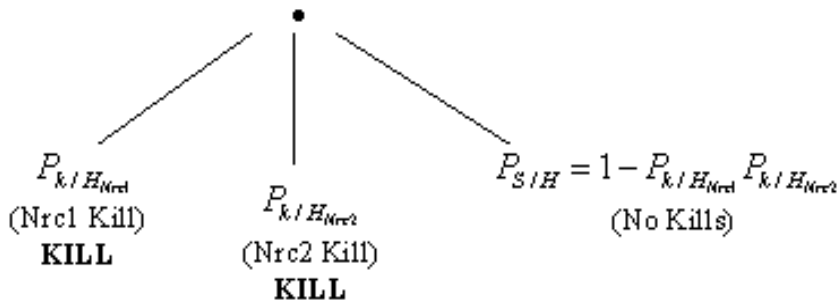

Figure 10. Kill Tree Diagram: First Hit, Nonredundant Model

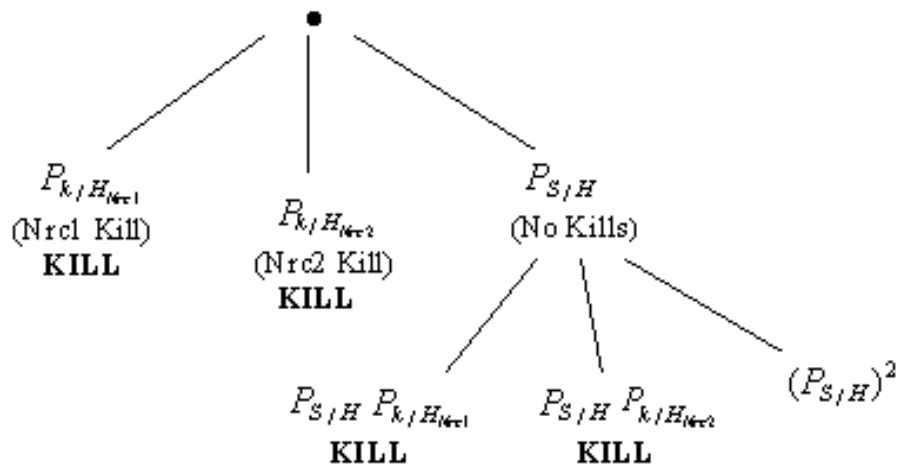

Figure 11. Kill Tree Diagram: Second Hit, Nonredundant Model

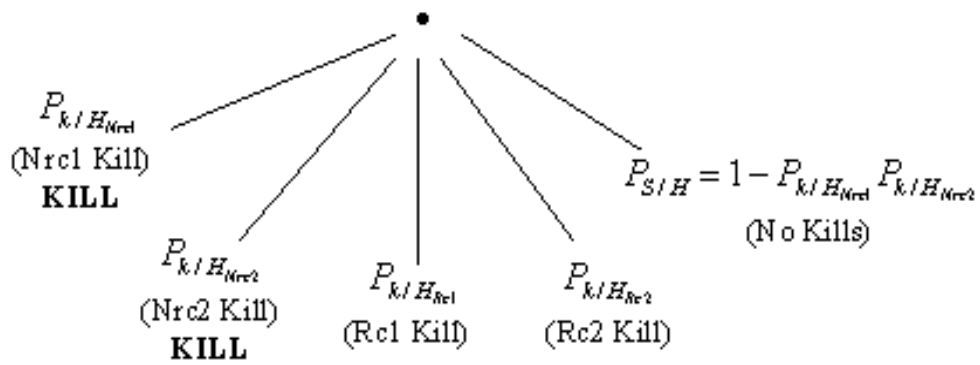

Figure 12. Kill Tree Diagram: First Hit, Redundant Model

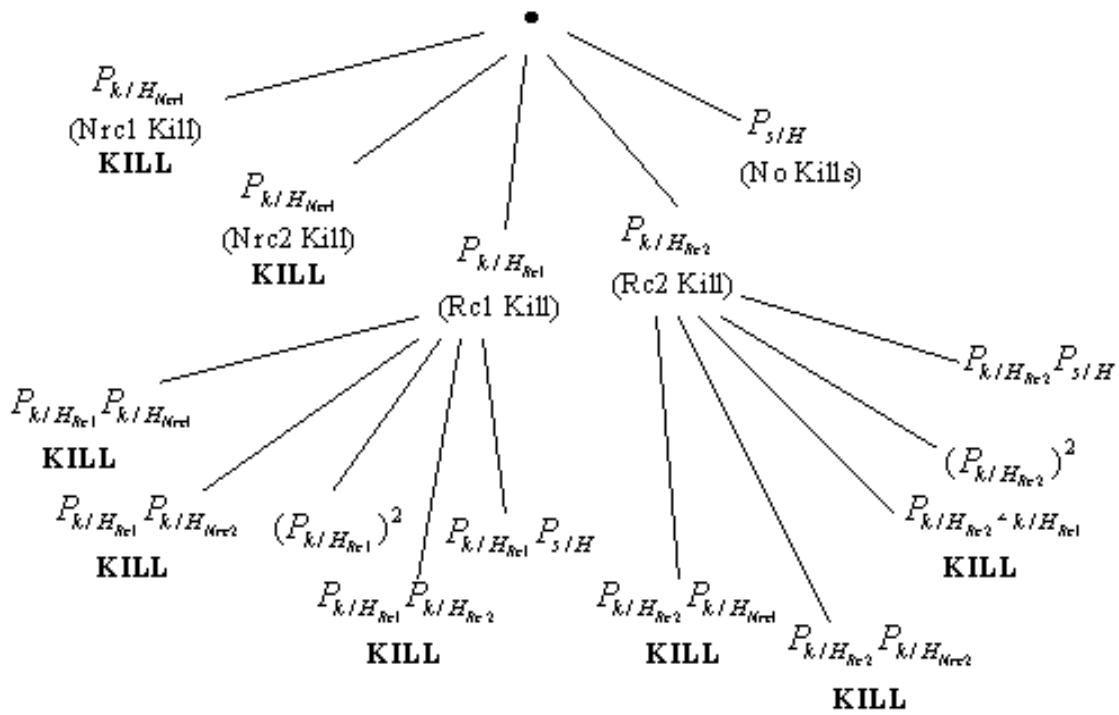

Figure 13. Kill Tree Diagram: Second Hit, Redundant Model

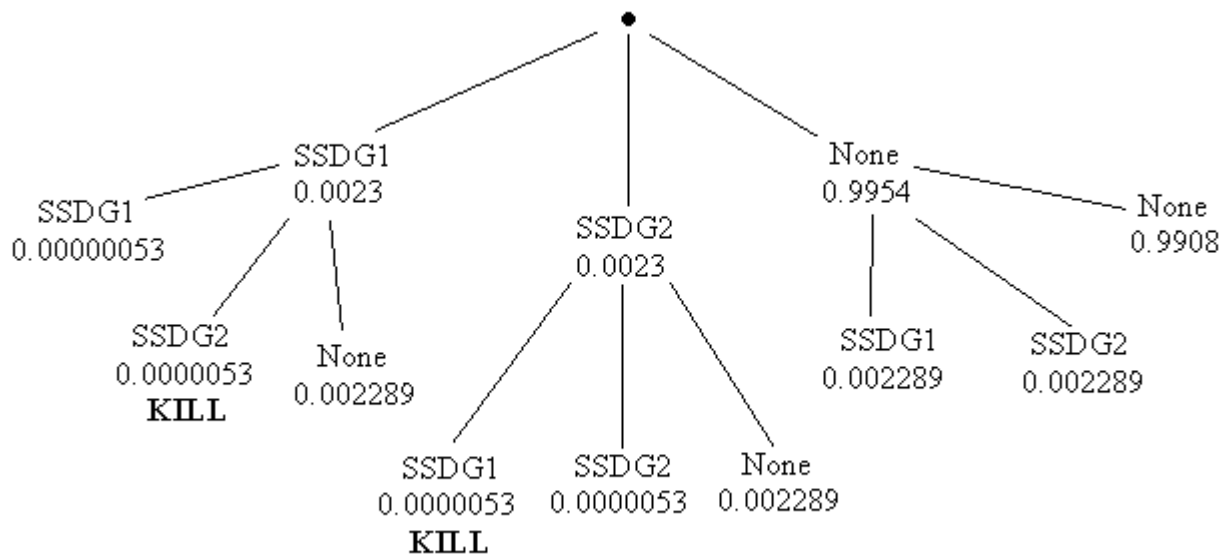

Figure 14. Kill Tree Diagram: Second Hit, Cyclone-Class Model

b. State Transition Matrix

The state transition matrix method assumes that a series of random hits on a craft can be modeled as a Markov process. This process defines the state of a craft based on the possible combinations of critical component kills or survivals. A very general example can be used to illustrate how this method might be used for a small craft. For this example, it will be assumed that the critical components of the small craft are only the two ship's service diesel generators. The vulnerable area data for these components is listed in Table 5.

A small craft consisting of two SSDGs can exist in four distinct states:

- (a) Only SSDG1 has been killed, denoted by *krc1*
- (b) Only SSDG2 has been killed, denoted by *krc2*
- (c) Both SSDG1 and SSDG2 have been killed, resulting in a craft kill, denoted by *Krc*
- (d) Neither SSDG1 nor SSDG2 have been killed, denoted by *nk*.

State (c) is called an absorbing state, because the small craft cannot transition from this kill state to any of the other nonkill states, since, in state (c) the craft has been effectively killed.

Ball's method prescribes that a transition matrix, $[T]$, a matrix of probabilities be constructed. This matrix specifies how the small craft transitions from state to state, as a result of a hit. Table 6 illustrates the general form of the $[T]$ matrix for this example, and Table 7 shows the actual $[T]$ matrix.

Note that the sum of each of the columns in matrix $[T]$ is one. This makes sense, since the probability that any nonkill state will transition to any other state after a hit is one and the probability that a kill state will remain a kill state after a hit is also one. The $[T]$ matrices presented in this thesis are meant only for the purpose of exemplifying the applicability of Ball's method. They are by no means complete and many more critical components would need to be considered for them to be meaningful in a vulnerability assessment.

Table 5. Data for State Transition Matrix

Critical Component	A_{v_i} (ft ²)
SSDG1	6.6
SSDG2	6.6
$A_p = 2820 \text{ ft}^2$	

Table 6. General State Transition Matrix [T] for Sample Small Craft

Probability of Transitioning from this State					To this state
	Krc	krc1	krc2	nk	
$\frac{1}{A_p}$	$krc1 + krc2$	$krc2$	$krc1$	$krc1 + krc2$	Krc
	0	$krc1 + (A_p - krc1 - krc2)$	0	0	krc1
	0	0	$krc2 + (A_p - krc1 - krc2)$	0	krc2
	0	0	0	$A_p - krc1 - krc2$	nk

Table 7. State Transition Matrix [T] for Sample Small Craft

Probability of Transitioning from this State					To this state
	Krc	krc1	krc2	nk	
$\frac{1}{2820}$	2820	6.6	6.6	6.6 + 6.6	Krc
	0	$6.6 + (2820 - 6.6 - 6.6)$	0	0	krc1
	0	0	$6.6 + (2820 - 6.6 - 6.6)$	0	krc2
	0	0	0	$2820 - 6.6 - 6.6$	nk

The feasibility of these matrices proves that the state transition method is applicable to small craft. Further manipulation of [T] yields a value for $\bar{P}_{K/H}^{(n)}$, the probability of a craft kill given n hits.

c. **Simplified Method for $\bar{P}_{K/H}^{(n)}$**

Another means of obtaining $\bar{P}_{K/H}^{(n)}$ is Ball's simplified method. With this technique, the assumption that individual component kills are mutually exclusive for any one hit is neglected. Then, if the probability of survival after one hit on the craft is known for each critical component, an approximation for the probability that the craft has been killed by n hits can be obtained. This approximation can be used for a craft with both redundant and nonredundant critical components. The following equation approximates the probability of survival

$$\bar{P}_{S/H}^{(n)} = \prod_{i=1}^M (1 - \bar{P}_{k/H_i}^{(n)}) (1 - \prod_{j=1}^N \bar{P}_{k/H_j}^{(n)})$$

where there are M nonredundant components and N redundant components, and where

$$\bar{P}_{k/H_i}^{(n)} = 1 - (1 - P_{k/H_i})^n$$

and

$$P_{k/H_j}^{(n)} = 1 - (1 - P_{k/H_j})^n .$$

Continuing the simple example that was used for the state transition matrix, using a sample small craft with only two redundant critical components (SSDG1 and SSDG2) and no nonredundant critical components, the following calculations can be made for five hits on the craft

$$\begin{aligned} \bar{P}_{S/H}^{(5)} &= [1 - 0^5][1 - (1 - (1 - P_{k/H_{SSDG1}})^5)(1 - (1 - P_{k/H_{SSDG2}})^5)] \\ &= [1][1 - (1 - (1 - 0.2)^5)(1 - (1 - 0.2)^5)] = 0.935 . \end{aligned}$$

Again, this shows that Ball's method is applicable to small craft.

d. **Multiple Hit Vulnerable Area**

For craft with redundant critical components, which most small craft are, the probability of a kill given a hit and the corresponding vulnerable area change with each hit. This is due to the fact that the possibility of the loss of one or more of the redundant components increases with each hit. An event-based probability will lead to more accurate vulnerable area calculations, because the probability of a craft kill on the

n^{th} hit depends on whether or not it has survived the first $n-1$ hits. Ball expresses this with the following equation

$$\bar{P}_{S/H}^{(n)} = \bar{P}_{S/H}^{(n-1)}(1 - P_{K/H}^{(n)})$$

which can be rearranged to give

$$P_{K/H}^{(n)} = \frac{\bar{P}_{K/H}^{(n)} - \bar{P}_{K/H}^{(n-1)}}{1 - \bar{P}_{K/H}^{(n-1)}}$$

The value for $P_{K/H}^{(n)}$ can then be used to calculate a more accurate vulnerable area for a redundant craft using

$$A_V^{(n)} = A_P P_{K/H}^{(n)}$$

This method would obviously be applicable for small craft, since it is simply a modification of previously discussed techniques.

B. INTERNALLY DETONATING WARHEADS

Ball's method of computing vulnerability measures continues with internally detonating warheads. Most guided missiles and large projectiles are equipped with contact fuzes. Such a fuze will detonate the warhead either immediately or shortly after impacting a craft. Along with detonation come issues not addressed in the previous discussion of nonexplosive penetrators and fragments, those of blast and fragment spray. When a warhead detonates inside a craft, it sends a spray of fragments out radially from the warhead burst point. This means that the fundamental assumption made in the previous nonexplosive penetrator vulnerability assessment, that of parallel shotlines for all fragments, will not hold true for internally detonating warheads. The vulnerability measures that must be calculated for internally detonating warheads are the probability of a craft kill given a random hit and the probability of a kill of any of the components that lie on any of the radial fragment shotlines. Ball proposes two methods for calculating these probabilities: (1) the expanded area approach and (2) the point burst approach.

1. Expanded Area Approach

The expanded area approach is a simple method using the same basic principles that have already been discussed. Intuition says that the probability that a fragment hits a given critical component should increase now that the assumption of parallel shotlines is

gone. One way to model this increase in the likelihood of a hit is by expanding the presented area of the given critical component. This allows for the computation of P_{k/H_i} in the same manner as was used for the nonexplosive penetrator, including the treatment of overlapping areas. For example, in aircraft one critical component is the pilot. The presented area of the pilot when faced with a nonexplosive penetrator is the actual physical size of the pilot. For an internally detonating warhead, the expanded presented area of the pilot is the entire presented area of the cockpit, because if the warhead burst point is located anywhere within the cockpit, the pilot will most likely be hit.

The same method can be applied to small craft. For the example of the *Cyclone*-class patrol craft, the number one ship service diesel generator is one critical component. It is located in the forward engine room. If the warhead burst location is anywhere within the forward engine room, there is a good chance that SSDG1 will be hit. Because of this, the expanded presented area of SSDG1 can be the entire presented area of the forward engine room. Furthermore, the number one and number four main propulsion diesel engines are also located in the forward engine room, meaning that they will have the same expanded presented areas. These three areas overlap completely, which can be treated in the same manner as the overlap case for nonexplosive penetrators.

The compartmentalization that is inherent to naval ships aids in the process of defining expanded presented areas for critical components. If it is assumed that fragment spray cannot penetrate the watertight bulkheads on a ship, then each watertight compartment can potentially be the expanded presented area of one or more critical components within each compartment. This is not to say that the presented area of compartments is always the most appropriate value for the expanded presented area of a critical component within the compartment.

The idea of considering the entire space rather than just the critical component is very much like the ship design convention of identifying the “vital spaces” on a surface ship. Vital spaces are those compartments of which continued operation is essential for maintaining ship control, propulsion, communications, seaworthiness or fighting capability. The vital spaces on the *Cyclone* are: Pilot House, Electronics Room, CIC, Crypto Room, Forward Magazine, Engine Operating Station, Aft Magazine, Auxiliary Machine Room No. 1, Auxiliary Machine Room No. 2, Forward Engine Room, Aft

Engine Room, and Steering Compartment. [Ref 8] If a warhead burst is located within any of these vital spaces, there is a chance that at least one fragment will hit at least one component that is critical on some level. The distinction that should be made is that vital spaces are essential for the prevention of a kill at any level—system, mission, mobility, and total. Therefore, these spaces contain critical components that are relatively critical based on which kill level is being assessed. Nonetheless, these vital spaces can often be useful when defining expanded presented areas for critical components.

For the *Cyclone*-class, using the main engines as critical components, the expanded areas are shown in Figure 15. Some sample P_{k/H_i} values are given in Table 8.

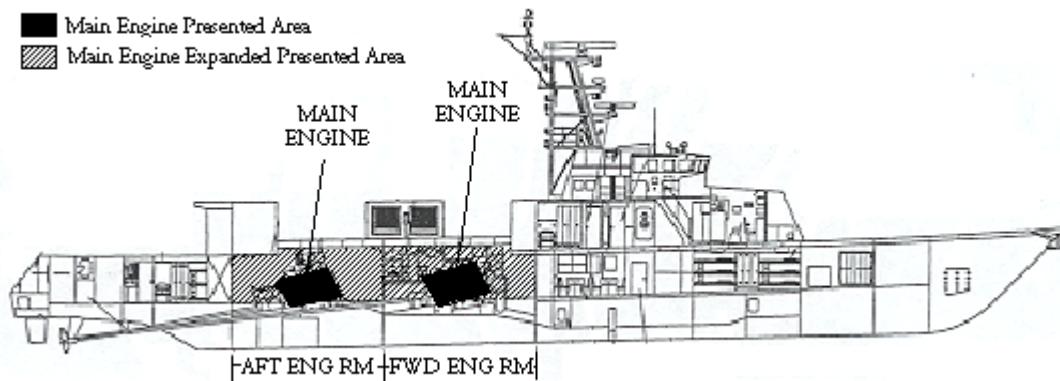

Figure 15. Expanded Area Approach for *Cyclone*-Class [From Ref. 7]

Table 8. Sample Vulnerability Measures for the *Cyclone*-Class against Internally Detonating Warheads

Critical Component	A_{p_i} (ft ²)	A_{pe_i} (ft ²)	P_{k/h_i}	A_{v_i} (ft ²)	P_{k/H_i}
Main Propulsion Engine	77.0	180	0.3	54	0.0194
Forward Shaft	20.7	30	0.45	13.5	0.0048
Aft Shaft	11.1	20	0.45	9	0.0032
Diesel Generator	33.0	100	0.4	40	0.0142

2. Point Burst Approach

The second approach that Ball offers for computing the vulnerability measures of a craft against an internally detonating warhead is the point burst approach. For this method, a grid is superimposed over the presented area of the craft. Each cell of the grid contains a randomly located burst point. The probability of a craft kill is calculated for each burst location. This method allows for more than one critical component to be killed at once. The probability of a craft kill is dependent on the relative location of critical components and shielding provided by critical and non-critical components. This method helps to create a point burst field that has a random nature, but also offers complete coverage of the craft. With this method, the grid is only used as a means of placing the point bursts; it does not confine the actual effects of the burst. When the probability of a ship kill is calculated for a given burst in a given grid cell, damage to components both inside and outside the grid cell are considered. This is much like the method that is currently used for ship survivability in the Ship Vulnerability Model (SVM), which implies that the method should be applicable to small surface craft.

The probability of a craft kill is calculated in much the same manner for this method as in the methods previously discussed. First, the probability of a craft kill given a hit, P_{K/H_b} , is determined for every burst point. This value is established by examining each cell, determining which components (internal or external of the cell) would likely be killed if there were a hit in that cell at the location of the burst point. The probability that those components are killed given a hit at the burst point can be calculated through nonexplosive penetrator/fragment methods previously discussed. From all of this, the probability of a craft kill given a hit at the specified burst point can be calculated. The product of this value and the probability of a random shot hitting the burst point area, P_{H_b} , gives the probability of a craft kill given a random hit, $P_{K/H}$. The probability of a random shot hitting the burst point area is given by Ball as

$$P_{H_b} = \frac{A_b}{A_p}, \quad b = 1, 2, \dots, B$$

where B is the total number of burst points to be considered and A_b is the presented area of the cell containing the given burst point. Ball offers the following equations to calculate the $P_{K/H}$ function and the vulnerable area of the craft A_V

$$P_{K/H} = \sum_{b=1}^B P_{H_b} P_{K/H_b} = \frac{1}{A_P} \sum_{b=1}^B A_b P_{K/H_b} = \frac{1}{A_P} \sum_{b=1}^B A_{v_b}$$

$$A_V = \sum_{b=1}^B A_b P_{K/H_b} = \sum_{b=1}^B A_{v_b}$$

where A_{v_b} is the vulnerable area of the b^{th} cell.

In the point burst method, it is important to define the potential expanse of damage for the given warhead. This value aids in the determination of what components will be affected by a given burst. The size of the burst and the amount of damage that it can cause depend on several factors. The most crucial of these is the weight of the explosive. Figure 16 shows the relationship between the blast damage volume and the weight of the explosive for TNT. With the help of figures like this one, vulnerability of a small craft to internally detonating warheads can be calculated using the point burst approach. [Ref. 4]

For the example of the Cyclone-Class, the point burst approach can be used directly. Figure 17 illustrates the point burst grid superimposed over the presented area of the Cyclone. Each cell contains one randomly located burst point.

C. EXTERNALLY DETONATING WARHEADS

Ball's method of computing vulnerability measures continues with externally detonating warheads. Most large caliber projectiles and several air-to-surface missiles employ externally detonating warheads. Furthermore, non-contact fuzed mines detonate at some stand-off distance exterior to the craft they pursue. When a craft encounters an externally detonating warhead, it faces potential damage from the blast or shock as well as from the fragments generated at detonation. Ball's method does not address shock, as it is strictly a phenomenon of underwater explosions. The vulnerability of a craft to each of these three damage mechanisms can be examined separately.

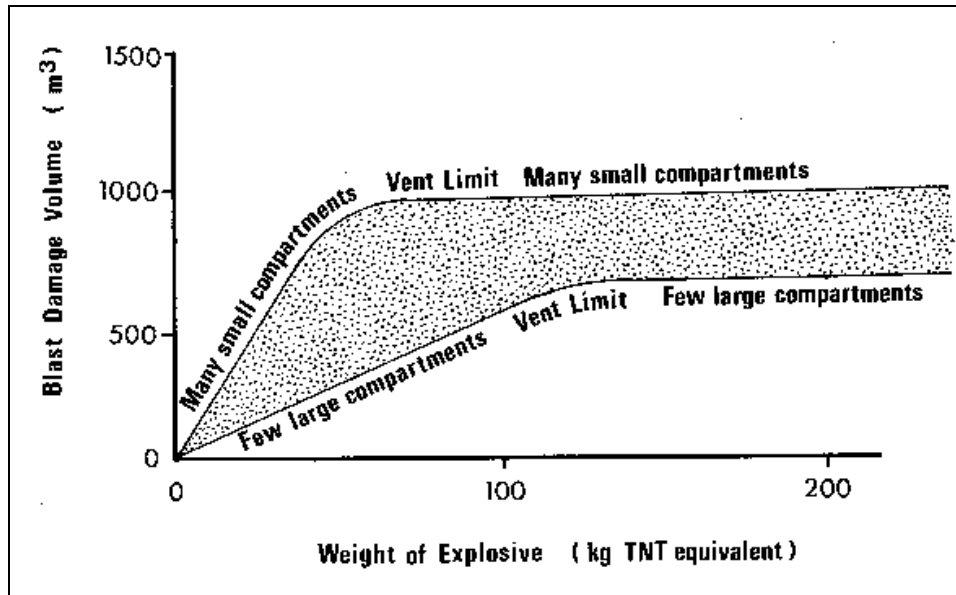

Figure 16. Increase of Damage Volume with Weight of Explosive [From Ref. 9]

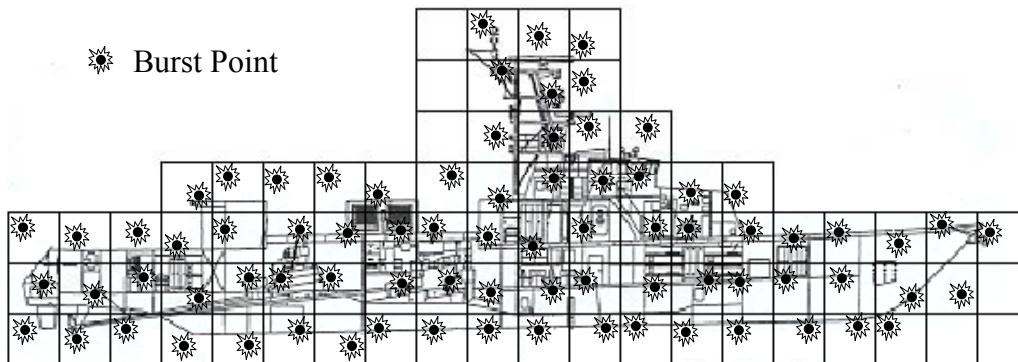

Figure 17. Burst Point Approach for the *Cyclone*-Class

1. Blast

In order to determine the vulnerability of the craft to blast, the damage criteria for blast pressure must be calculated for each critical component. Each critical component has a blast pressure threshold above which it will be killed. This is strictly a function of the component and its make-up. The blast pressure created by an externally detonating warhead is a function of the type of explosive, the weight of the charge, and the stand-off distance at the time of detonation. With this data, the minimum stand-off distance of a

given charge can be calculated for any of the kill levels. Ball indicates that this information is generally illustrated in one of two ways: a plot of charge weight versus stand-off distance for a constant kill level; or external blast kill isocharge contours about a craft for a constant kill level. Either or these can be constructed for a small craft. Typically, a spectrum of common combinations of charge types and weights are considered for either of these presentations.

2. Fragments and Penetrators

When an externally detonating warhead detonates, the fragments or penetrators that result from the detonation eject in a relatively uniform manner. Ball assumes that they eject completely uniformly around the missile axis, and radiate outward in a divergent spherical-like spray pattern. The damage to the craft that is caused by these penetrators is dependent upon the number and location of fragment or penetrator impacts on the craft, the average mass of the fragment or penetrator, and the fragment or penetrator impact velocity. The vulnerability measure that is typically computed for fragments or penetrators from an externally detonating warhead is $P_{K/D}$, the probability of a craft kill due to the burst of a specific type of explosive, for a specific set of encounter conditions. The encounter conditions include the altitude and relative position of the warhead, the velocities of the craft and the warhead at the time of detonation, and the fragment or penetrator static velocities and static spray angles. $P_{K/D}$ depends on the number of fragments or penetrators that actually impact the craft, and the craft's vulnerability to those hits.

The method for calculating $P_{K/D}$ corresponds to the method Ball offers to calculate multiple hit vulnerability with respect to nonexplosive penetrators or fragments. For externally detonating explosives, however, it is possible to estimate the number of hits on the craft based on the encounter conditions. Figure 18 illustrates an assumed encounter between an externally detonating missile and the *Cyclone*-class patrol craft. The angles ϕ_1 and ϕ_2 represent the leading and trailing fragment dynamic trajectories, respectively, and R is the distance from the point of detonation to the craft.

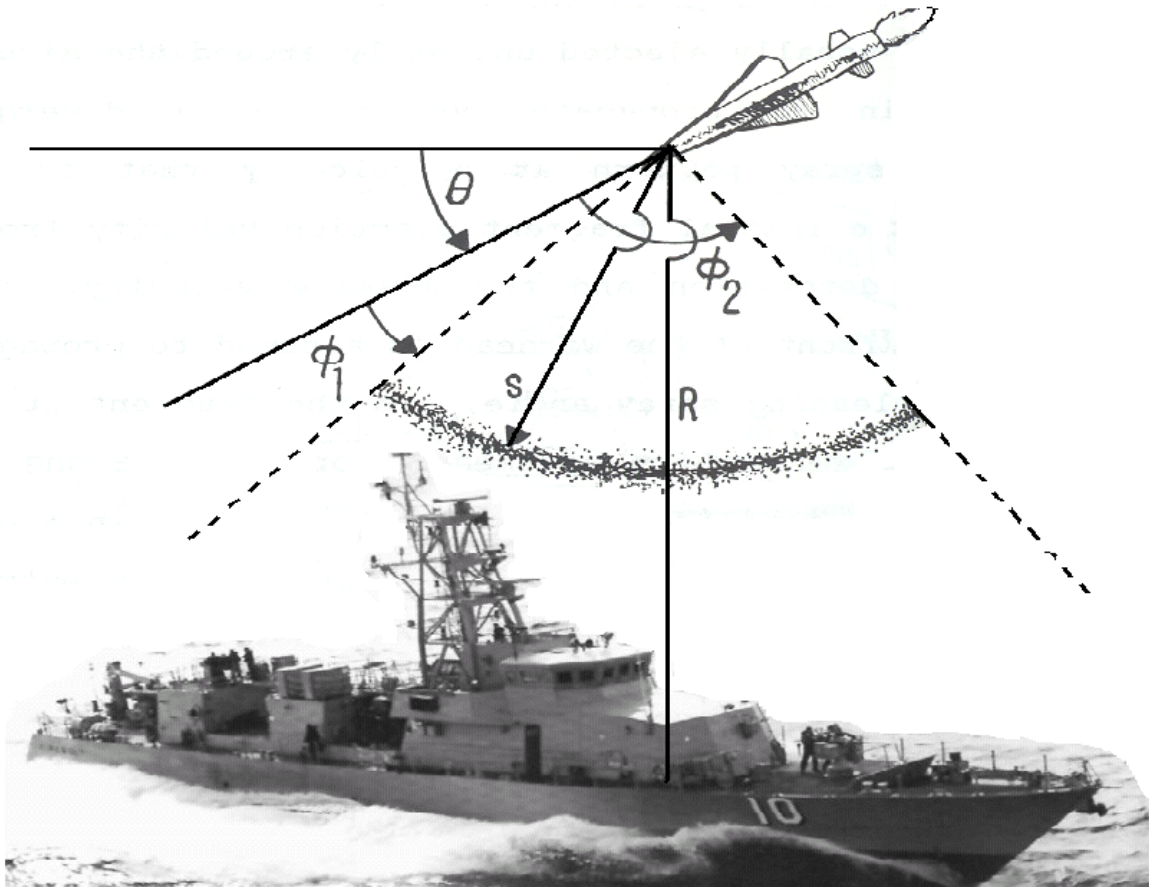

Figure 18. Assumed Encounter between Externally Detonating Warhead and the *Cyclone*-Class Patrol Craft [After Ref. 2]

In order to estimate the number of hits on the craft, Ball assumes that the entire presented area is hit by a spray of fragments or penetrators. These fragments or penetrators are assumed to travel along parallel trajectories and impact the craft randomly. Ball offers the following equation for the number of hits, n , on the presented area of the craft

$$n = \rho A_p$$

where ρ is the fragment spray density (average number of fragments per unit area of fragment spray).

The fragment spray density can be solved for using a more realistic set of assumptions about the spray. To do this, Ball assumes that the fragments have uniform velocity, and are uniformly spread over a spherical segment between ϕ_1 and ϕ_2 , with

respect to a stationary target. For a warhead with N total fragments, at a distance s from the detonation point, the fragment spray density is given by the following equation

$$\rho = \frac{N}{2\pi s^2 (\cos \phi_1 - \cos \phi_2)}.$$

Ball defines angles ϕ_1 and ϕ_2 with the following equation

$$\phi_i = \arctan \left[\frac{V_m \sin \theta + V_f \sin(\theta + \alpha_i)}{V_m \cos \theta + V_f \cos(\theta + \alpha_i) - V_t} \right] - \theta \quad i = 1, 2$$

where V_m is the missile speed, V_f is the average fragment or penetrator speed with respect to a stationary warhead, V_t is the target speed, θ is the missile elevation angle, and α_i is the fragment or penetrator spray angle from the axis of a static warhead detonation for either the leading or trailing fragment/penetrator.

Once the number of hits is determined, the problem becomes identical to one of multiple hit vulnerability against nonexplosive penetrators or fragments, which has already been covered, and shown to work for small craft. The probability that a craft is killed by n random hits, $\bar{P}_{K/H}^{(n)}$, is equivalent to $P_{K/D}$. Because of this, the simplified method for $\bar{P}_{K/H}^{(n)}$ can be used to assess the vulnerability of the craft. This is expanded upon in the following derivations from Ball:

$$\bar{P}_{K/H}^{(n)} = P_{K/D} = 1 - \prod_{j=1}^n (1 - P_{K/H}^{(j)})$$

where $P_{K/H}^{(j)}$ is the probability of a craft kill on the j^{th} random hit. For small $P_{K/H}^{(j)}$

$$\prod_{j=1}^n (1 - P_{K/H}^{(j)}) \cong \exp \left(- \sum_{j=1}^n P_{K/H}^{(j)} \right)$$

and

$$\sum_{j=1}^n P_{K/H}^{(j)} = \sum_{j=1}^n \frac{A_V^{(j)}}{A_P}$$

therefore,

$$P_{K/D} \cong 1 - \exp\left(-\frac{\rho}{n} \sum_{j=1}^n A_V^{(j)}\right)$$

Since $A_V^{(j)}$ is assumed to remain constant for all hits,

$$P_{K/D} \cong 1 - \exp(-\rho A_V).$$

For the example of the Cyclone-class patrol craft, facing given encounter conditions, these formulae can be directly applied to compute the vulnerability to the spray from an externally detonating warhead. Certain information about the warhead and the craft must be known or assumed in order to perform the calculations. An example calculation of $P_{K/D}$ for the Cyclone-class is shown in conjunction with Table 9. This example illustrates one of the many examples in which Ball's specific techniques for the assessment of aircraft vulnerability can be directly applied to the small craft.

The calculation of the fragmentation dynamic spray angles is completed as follows

$$\phi_1 = \arctan\left[\frac{(1500)\sin(30^\circ) + (7000)\sin(30^\circ + 50^\circ)}{(1500)\cos(30^\circ) + (7000)\cos(30^\circ + 50^\circ) - (42.2)}\right] - (30^\circ) = 42.1^\circ$$

$$\phi_2 = \arctan\left[\frac{(1500)\sin(30^\circ) + (7000)\sin(30^\circ + 120^\circ)}{(1500)\cos(30^\circ) + (7000)\cos(30^\circ + 120^\circ) - (42.2)}\right] - (30^\circ) = 108.5^\circ$$

Fragment spray density is then calculated by

$$\rho = \frac{(1000)}{2\pi(80)^2 [\cos(42.1^\circ) - \cos(108.5^\circ)]} = 0.0235 \text{ fragments/ft}^2$$

And finally, the probability of a ship kill can be calculated

$$P_{K/D} \cong 1 - \exp(-0.0235 \times 50) = 0.691.$$

Table 9. Given Data for Example Computation of $P_{K/D}$ for the *Cyclone*-Class
[After Ref. 2]

Static Warhead Parameters	Leading Spray Angle	$\alpha_1 = 50^\circ$
	Trailing Spray Angle	$\alpha_2 = 120^\circ$
	Number of Fragments or Penetrators	$N = 1000$
	Fragment Velocity	$V_f = 7000 \text{ ft} / \text{s}$
Encounter Parameters	Missile Speed	$V_m = 1500 \text{ ft} / \text{s}$
	Missile Angle	$\theta = 30^\circ$
	Detonation Distance	$R = 80 \text{ ft}$
	<i>Cyclone</i> Speed	$V_t = 25 \text{ knots}$ $= 42.2 \text{ ft} / \text{s}$
<i>Cyclone</i> Parameters	<i>Cyclone</i> Presented Length	$L_t = 170 \text{ ft}$
	Sample Aspect Vulnerable Area for the Given Threat	$A_v = 50 \text{ ft}^2$

3. Shock

Shock is a phenomenon that occurs due to an underwater explosion. Obviously, Ball does not cover the effects of shock on an aircraft in his vulnerability assessment. For this reason, the vulnerability of the *Cyclone*-class to shock will be left unexamined, as the focus of this thesis is the applicability of aircraft vulnerability measures to small surface craft. This is one particular instance where the aircraft vulnerability methods cannot be directly applied to small craft.

D. VULNERABILITY TO LASERS

Vulnerability to lasers is treated in the same manner as vulnerability to the single nonexplosive penetrator.

E. VULNERABILITY TO UNCONVENTIONAL WEAPONS

Ball does not address the vulnerability of an aircraft to unconventional weapons. In today's environment, however, unconventional weapons are being seen as an increasing threat to both surface craft and aircraft alike. The U.S. Coast Guard is currently using the *Cyclone*-class for homeland security purposes. The potential threats that come with this mission include a very real threat from unconventional weapons. Because of this, a thorough vulnerability assessment of the *Cyclone*-class would include its vulnerability to unconventional weapons. This is another instance where the aircraft vulnerability methods proposed by Ball are not sufficient for small craft.

IV. VULNERABILITY REDUCTION

A. VULNERABILITY REDUCTION CONCEPTS

Vulnerability reduction concepts are means of controlling or reducing the amount of damage to a craft caused by damage mechanisms. Ball offers several specific techniques to reduce craft vulnerability. These techniques include:

- Component Redundancy with Separation
- Component Location
- Passive Damage Suppression
- Active Damage Suppression
- Component Shielding
- Component Elimination

Most of these concepts are self-explanatory, however some need further explanation. Passive damage suppression, for example, is any design technique that, without damage-sensing capabilities, reduces or contains the effects of damage after the impingement of a damage mechanism. Ball offers the following passive damage suppression techniques as viable vulnerability reduction concepts:

- Damage Tolerance
- Ballistic Resistance
- Delayed Failure
- Leakage Suppression
- Fire and Explosion Suppression

Active damage suppression is any technique that, with the help of a sensor or other detection device, reduces or contains the effects of damage after impingement of a damage mechanism.

B. *CYCLONE*-CLASS DESIGN FOR REDUCED VULNERABILITY

The major systems of small craft in general, and the *Cyclone*-class specifically, are the propulsion system, electric system, auxiliary system, structural system, and crew system. Using Ball's vulnerability reduction concepts, a brief description of vulnerability reduction to each of these systems is presented below. The discussion includes general principles that can be applied to all small craft vulnerability reduction processes, as well

as descriptions of how some of these principles might be applied specifically to the *Cyclone*-class patrol craft (or how they could have been applied during her design phase).

1. Propulsion System

The propulsion system is considered to include the main propulsion engines, the fuel oil subsystem, the lubrication subsystem, the controls, and the power train and propeller subsystem.

a. Kill Modes

Possible damage-caused failure modes of the propulsion system are engine failure, fuel supply depletion, in-tank fire and explosion of fuel oil, lubrication starvation, in-tank fire and explosion of lubrication oil, propulsion controls failure, and power train or propeller failure. [Ref. 4]

b. Design Guidance and Vulnerability Reduction Techniques

(1) Prevention of Engine Failure. The propulsion system of the *Cyclone*-class has been designed in accordance with many of Ball's vulnerability reduction concepts. There is redundancy among the most critical components. There are four of each of the main propulsion engine, shaft, gearbox, and propeller. In order for redundancy to be effective, there must be separation such that one hit will not directly or indirectly kill more than one redundant component. Due to the overall size of the *Cyclone*, there is limited space for separation. By locating the two engine rooms adjacent to one another there is little chance for significant separation of the critical propulsion components. In the aft engine room there is even less separation than in the forward engine room since main engines number two and three are on inboard shafts, resulting in a lateral separation of only a narrow passageway between them. The design of the *Cyclone*-class would have been made less vulnerable if the two engine rooms had not been located adjacent to one another. This, however, was most likely not feasible due to stability restrictions having to do with the location of the center of gravity of the ship. With adjacent engine rooms, the design could have been made slightly less vulnerable by locating engines one and four as far forward as possible in the forward engine room while locating engines two and three as far aft as possible in the aft engine room. This would have decreased the vulnerability slightly as it would have provided a few more feet of separation.

Another method that could be used to prevent engine failure on the *Cyclone* is to insert ballistic and/or fire resistant material, or a shield, between laterally adjacent engines. This would create a material, rather than geographic separation between the redundant components because it would decrease the likelihood that a single hit could kill more than one of the components. This is a good technique for decreasing vulnerability when there is not a lot of room for critical component separation.

(2) Prevention of Fuel Supply Depletion. There are three fuel oil tanks onboard the *Cyclone*-class. The forward fuel tanks are located on the port and starboard side of the fourth watertight subdivision, below the galley/mess deck. The after fuel tank is located in the seventh watertight compartment, below the after crew berthing. This tank is surrounded by a void on three sides. The prevention or minimization of fuel leakage is essential for the prevention of fuel supply depletion. Because, however, there is redundancy and effective separation among the fuel tanks, fuel supply depletion is not a significant threat for the *Cyclone*-class. [Ref. 7]

(3) Prevention of In-Tank Fire and Explosion of Fuel Oil or Lubrication Oil. Prevention of fire and explosion can be accomplished using either passive or active techniques. The methods in Table 10 are techniques suggested by Ball for fire and explosion prevention, all of which could be directly applied to small craft in general.

Table 10. Some Techniques for Preventing Fires and Explosions [From Ref. 2]

Passive Techniques	Active Techniques
Flexible, reticulated polyurethane foam	Ignition source/flame front detection and combustion suppression
Rigid, closed-cell ballistic foam	Hydraulic ram detection and combustion suppression
Fibrous filler	Fire detection and fire extinguishing
Expanded aluminum batts	
Nitrogen inerting (liquid, gaseous, or onboard generation)	
HALON inerting	
Antimisting fuel	
Powder packs	
Purge mats	
Void space venting with air	
Fire walls	

The *Cyclone* is equipped with damage control equipment, which can aid in recovering from a fire. As the focus of this thesis is on vulnerability reduction rather than recoverability, small craft damage control systems will not be addressed.

(4) Prevention of Lubrication Starvation. Ball maintains that one of the most important techniques for reduction of propulsion system vulnerability is a fail-safe or damage-tolerant lubrication system. Fail-safe designs contain components that will revert to marginally operable conditions for a specified or indefinite period of time after the impingement of the damage mechanism. Damage tolerance refers to the ability of a system to accept a degree of mechanical damage without the impairment of its functional capability. Oil sump, lines, and tanks are extremely susceptible to penetration by even the smallest penetrator if their vulnerability has not been specifically addressed. Ball proposes the use of self-sealing lines, shielding, and armor as means of protecting the lubrication system. Furthermore, bypass lines that isolate damage or leaking lines can further decrease the vulnerability of a craft to lubrication loss. These methods are just as applicable to small craft as they are to aircraft.

(5) Prevention of Propulsion Controls Failure. In most small craft, the propulsion system is controlled with an electro-mechanical system that uses electrical signals from the command levers to provide input to the electronic governor. The propulsion control system of the *Cyclone*-class is usually controlled from one of the following locations: the pilot house; the port and starboard bridge wings; the engineering operating station (EOS); or in an emergency, at local control panels within the engine room [Ref. 7]. The redundancy and effective separation among these propulsion controls stations indicates that the propulsion controls system adequately designed with respect to vulnerability.

(6) Prevention of Power Train and Propeller Failure. The power train and propeller subsystem consists of the shafts, gearboxes, and propellers that transmit power from the engines to the propellers of a small craft [Ref. 8]. The most likely kill modes of the power train and blade system are loss of lubrication and mechanical or structural failure. In general, power train and propeller failure can be prevented through the employment of redundant and separated load paths, as well as damage-tolerant materials. The damage-tolerance techniques for the prevention of lubrication starvation mentioned above will also decrease the likelihood of shaft,

gearbox, or propeller failure due to lubrication starvation. In general, Ball recommends the use of solid lubricants, high-temperature grease, and oil additives as less vulnerable lubrication techniques. These specific techniques can be directly applied to small craft. Mechanical and structural failure can be prevented with further use of damage tolerance. Shafts should be designed to provide safe operation after a certain degree of mechanical or structural damage. There are four gearboxes, shafts, and propellers, which makes each of these components redundant, but none possess a great deal of separation. Because this, shielding or ballistic resistance could be employed in order to decrease the likelihood of multiple kills given a single kill. Any portion of these components that cannot tolerate penetration by a damage mechanism should be shielded with noncritical components or ballistic-resistant armor. Portions of the drive train that are especially susceptible, such as shaft couplings and intermediate shaft supports, should also be either shielded or armored.

2. Electric System

The electronic system is considered to include the ship service generators, the AC lighting and power subsystem, the DC propulsion and power subsystems, the distribution system, and all electronic equipment. [Ref. 8]

a. Kill Modes

The possible damage-caused failure modes of the electrical system are mechanical or electronic failure of the electric system components.

b. Design Guidance and Vulnerability Reduction Techniques

(1) Prevention of Mechanical Failure of Electric System Components. The electric system onboard a small craft like the *Cyclone* is made up of components that are extremely susceptible to penetration by even the smallest penetrator if their vulnerability is not specifically addressed. Shielding and armor are typically the most feasible means of protecting these components. Here again, separated redundant components are useful for decreasing the vulnerability of the electric system. The *Cyclone* is equipped with two independent ship service diesel generators (SSDG). The generators are of adequate size to solely handle the entire load of the ship. Furthermore, they can be configured so that the off-line generator automatically starts and picks up the load in the event the online generator fails. SSG1 is located on the centerline in the forward part of the forward engine room. SSG2 is located in the after port section of the

aft engine room. This provides them with a decent amount of separation. Although the *Cyclone* does not have an emergency generator set, the class is equipped with a 24 volt direct current system that provides power to many of the critical electronic components including the main propulsion control system. Furthermore, in the event of a total loss of ship's service power, the engine starting battery banks can be employed for extremely critical functions. These emergency systems add an additional level of redundancy to the overall system, making it less vulnerable. [Ref. 7]

(2) Prevention of Electronic Failure of Electric System Components. Electronic failure can occur as the result of phenomena such as an electromagnetic pulse from a nuclear explosion. Anything that produces extremely high voltages can destroy electronic circuits and potentially render electronic equipment onboard ineffective. For protection against high voltage, electric equipment should be enclosed within a metal container, or grounded with metallic meshes incorporated into non-metallic structures. [Ref 9] These methods are just as applicable for aircraft as they are for small craft.

3. Auxiliary System

The auxiliary system of a small craft includes all the auxiliary subsystems that are generally essential for daily life and mission performance. In general, killing an auxiliary subsystem will cause only a system kill or a mission area kill, as defined in Chapter II. Because of this, the vulnerability reduction of the auxiliary system will not be discussed at length.

a. Kill Modes

Any of the auxiliary subsystems are susceptible to mechanical or structural failure.

b. Design Guidance and Vulnerability Reduction Techniques

The likelihood of mechanical or structural failure of the auxiliary subsystems can be decreased with the use of most of the methods that have already been discussed. Redundancy and separation of components that provide essential functions for the particular auxiliary system is crucial.

4. Structural System

The structural system consists of all the components of the craft that transmit and react to the inertial, hydrodynamic, and aerodynamic loads. The structure of a small craft

consists of the hull, the watertight bulkheads, the keel, the girders, the stringers, the deck, and the deckhouse.

a. Kill Modes

The possible damage-caused failure modes of the structural system are structural removal, pressure overload, thermal weakening, and penetration of any of the components of the system.

b. Design Guidance and Vulnerability Reduction Techniques

Significant vulnerability reduction for the structural system is difficult to accomplish after the design phase of the craft is complete. However, during the design process, it is important incorporate multiple load paths and crack stoppers into the system. These are means by which catastrophic structural failure can be prevented.

Structural vulnerability depends greatly on the materials with which the components are constructed. The *Cyclone* is an example of standard material selection for a U.S. Navy ship. With an aluminum deckhouse and a steel hull, the *Cyclone* has good structural survivability. However, not all small craft have steel hulls. Aluminum and lightweight composites are common choices for the hulls of small craft. In general, aluminum and composites, when used for components in the structural system, are more vulnerable to structural failure than steel counterparts. Structural vulnerability is just one aspect to bear in mind during the design phase, and material selection will ultimately be made based on many considerations.

6. Crew System

The crew system of a small craft consists of all the personnel onboard. For the *Cyclone* this means 30 crew and 9 SEALS or 9 U.S. Coast Guard personnel for a total complement of 39.

a. Kill Modes

The crew of a small craft can be affected directly or indirectly by the combat damage to a small craft. Directly, the crew can actually be hit by a damage mechanism. Indirectly, the crew can experience smoke, fire, flooding, or other secondary effects.

b. Design Guidance and Vulnerability Reduction Techniques

Again, many of the same methods for vulnerability reduction can be used for this system. Crew compartments should be redundant and separated. The *Cyclone* is

a good example of this, having the forward crew quarters located in the third watertight subdivision and the aft crew quarters located in the seventh watertight subdivision.

7. Other Systems

All other systems onboard a small craft can be treated in the same general manner as those listed above. The six vulnerability reduction principles of component redundancy with separation, component location, passive damage suppression, active damage suppression, component shielding, and component elimination can be applied to any system or subsystem.

V. CONCLUSION

The established aircraft vulnerability assessment and reduction techniques laid out by Robert E. Ball in *The Fundamentals of Aircraft Combat Survivability Analysis and Design* can be directly applied to small surface craft. Due to the similar natures of aircraft and small craft, Ball's methods are very applicable to small craft, and his theory, as well as his specific techniques, can be directly applied to them. The successful application of his methods and theory to the *Cyclone*-class patrol craft proves this.

Certainly there are areas of surface craft survivability theory not covered by Ball that should be addressed for a complete vulnerability assessment of a small craft. However, Ball's methods for aircraft are well established and can be used to provide useful information regarding the vulnerability of a small craft. For a complete vulnerability assessment, however, shock, flooding, and other such surface ship phenomena should be addressed.

THIS PAGE INTENTIONALLY LEFT BLANK

LIST OF REFERENCES

1. Ball, Robert E. and Charles N. Calvano, "Establishing the Fundamentals of a Surface Ship Survivability Design Discipline," Naval Engineers Journal, January 1994.
2. Ball, Robert E., *The Fundamentals of Aircraft Combat Survivability Analysis and Design*, American Institute of Aeronautics and Astronautics, Inc., New York, 1985.
3. Metcalf, Brian A., *Development of a Model to Predict and Assess Surface Ship Recoverability*, Naval Postgraduate School Thesis, December 2000.
4. Windsor, George B., *The Fundamentals of Ship Survivability and Design*, Naval Postgraduate School Thesis, March 1989.
5. Polidoro, Michael A., *The Use of Patrol Craft in Low Intensity Conflict Operations: An Alternative Model for the Employment of the Cyclone-Class (PC-1)*, Naval Postgraduate School Thesis, December 1995.
6. Commander, USCG Atlantic Area Public Affairs, "13 Navy Patrol Craft (PCs) Reassigned to Coast Guard for Homeland Security," USCG Public Affairs Release, January 2002.
7. Doyle, Dennis J., Joseph C. Mayer, and Frank N. McCarthy, "The Patrol Coastal Cyclone Class: A Description of the Newest Addition to the U.S. Navy," Naval Engineers Journal, May 1995.
8. *Ship Information Book for USS Cyclone PC-1*, Naval Sea Systems Command, January, 1992.
9. Gates, P. J., *Surface Warships*, Brassey's Defence Publishers, London, 1987.
10. "Cyclone Patrol Coastal Ships," Naval Forces, April 1995.

THIS PAGE INTENTIONALLY LEFT BLANK

INITIAL DISTRIBUTION LIST

1. Defense Technical Information Center
Ft. Belvoir, Virginia
2. Dudley Knox Library
Naval Postgraduate School
Monterey, California
3. Prof. C. N. Calvano
Mechanical Engineering Department
Naval Postgraduate School
Monterey, CA
4. Prof. Wayne Hughes
Operations Research Department
Naval Postgraduate School
Monterey, CA
5. Mr. Norm Yarbrough
(SEA 05P3)
Naval Sea Systems Command
Washington Navy Yard, D.C
6. Mr. Robert Wunderlick
Carderock Division
Naval Surface Warfare Center
West Bethesda, MD
7. Prof. Robert E. Ball
Naval Postgraduate School
Monterey, CA
8. ENS Julia Lillis
Erie, PA

THIS PAGE INTENTIONALLY LEFT BLANK