

ARMY RESEARCH LABORATORY

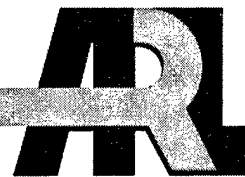

A Shaped Charge With Dual Confinement

by Daniel R. Scheffler and William P. Walters

ARL-TR-2791

August 2002

20020916 094

Approved for public release; distribution is unlimited.

NOTICES

Disclaimers

The findings in this report are not to be construed as an official Department of the Army position unless so designated by other authorized documents.

Citation of manufacturer's or trade names does not constitute an official endorsement or approval of the use thereof.

Destroy this report when it is no longer needed. Do not return it to the originator.

Army Research Laboratory

Aberdeen Proving Ground, MD 21005-5066

ARL-TR-2791

August 2002

A Shaped Charge With Dual Confinement

Daniel R. Scheffler and William P. Walters

Weapons and Materials Research Directorate, ARL

Abstract

A computational study was performed on a shaped charge device with a double confinement. This concept was previously introduced by Walters and Segletes (Walters, W.P., and S. B. Segletes. "Shaped Charge Devices With Multiple Confinements." U.S. Patent 5,847,312, 8 December 1998). The design involved using a dual (or multiple) confinement body on a shaped charge. The goals were to at least maintain the performance of the shaped charge jet and to allow dual (or multiple) waves of fragments from the explosive confinement casings. The computational results from the CTH code indicate that these objectives were accomplished.

Acknowledgments

The Department of Defense (DOD) high performance computing (HPC) resource allocation grant on high performance computing systems at the DOD Major Shared Resource Center located at the U.S. Army Research Laboratory, Aberdeen Proving Ground, MD was used to perform the computer simulations. Special thanks to Kent Kimsey, who acted as technical reviewer, for his many helpful suggestions.

INTENTIONALLY LEFT BLANK.

Contents

Acknowledgments	iii
List of Figures	vii
List of Tables	ix
1. Introduction	1
2. Problem Setup	2
3. Results and Discussion	3
3.1 Series 1 Simulations	3
3.2 Series 2 Simulations	5
3.3 Series 3 Simulations	7
4. Conclusions	8
5. References	31
Appendix A. Input Deck for Shpdbl1 Double Confinement Shaped Charge	33
Appendix B. Input Deck for Shpsgl2 Single Confinement Shaped Charge	41
Appendix C. Input Deck for Shpdbl3 Double Confinement Shaped Charge	49
Appendix D. Input Deck for Shpsgl4 Single Confinement Shaped Charge	57
Appendix E. Input Deck for Shpdbl5 Double Confinement Shaped Charge	65
Appendix F. Input Deck for Bilddb1 Double Confinement Shaped Charge	73
Appendix G. Input Deck for Billsgl1 Single Confinement Shaped Charge	81
Appendix H. Input Deck for Bilddb2 Double Confinement Shaped Charge	89
Appendix I. Input Deck for Billsgl2 Single Confinement Shaped Charge	97
Appendix J. Input Deck for Bilddb3 Double Confinement Shaped Charge	105
Appendix K. Input Deck for Bilddb4 Double Confinement Shaped Charge	113
Appendix L. Input Deck for Newshp1 Double Confinement Shaped Charge	121

Appendix M. Input Deck for Newshp2 Double Confinement Shaped Charge	129
Appendix N. Input Deck for Newbsl2 Double Confinement Shaped Charge	137
Appendix O. Input Deck for Waveshp2 Double Confinement Shaped Charge	145
Report Documentation Page	153

List of Figures

Figure 1. Dual confinement liner patent drawing [1]. The drawing shows an axisymmetric charge where 7 and 15 are explosive fills, 3 is the shaped charge liner, 12 and 21 are the confinement layers, 33 is the detonator, 31 is the booster, and 25 is the centering device.	9
Figure 2. Shaped charge geometries for series 1 simulations.....	10
Figure 3. Tracer data showing jet tip velocity for all series 1 simulations.	11
Figure 4. Density plots for simulations Shpdbl3 and Shpsgl4.....	12
Figure 5. Viper 66-mm shaped charge jet at 26.63 μ s [12].	13
Figure 6. Comparison of pressures at two times for dual confinement jet and its baseline, Shpdbl1 and Shpsgl2.....	14
Figure 7. Comparison of axial velocity profile of dual confinement jet with its baseline.....	15
Figure 8. Series 1 dual confined charges axial velocity profiles.	16
Figure 9. Shaped charge geometries for series 2 simulations.....	17
Figure 10. Comparison of series 2 jet tip velocity with series 1 for dual confinement shaped charge and its baseline.	18
Figure 11. Tracer data showing jet tip velocity for all series 2 simulations.	19
Figure 12. Detonation wave location at the time of inner explosive initiation for Billdbl3 and Billdbl4 simulations.	20
Figure 13. Comparison of series 2 dual confinement simulations sharing the same baseline (Billshp1).	21
Figure 14. Comparison of series 2 dual confinement simulations sharing a common baseline with the baseline (Billsgl1).	22
Figure 15. Comparison of reduced mass series 2 jet velocity with full-size counterparts.....	23
Figure 16. Shaped charge geometries for series 3 simulations.....	24
Figure 17. Comparison of jet tip velocity for series 3 simulations.....	25
Figure 18. Density plots for series 3 dual confined shaped charges at 20 and 60 μ s.	26
Figure 19. Axial velocity profiles for series 3 simulations at 30 and 50 μ s.	27
Figure 20. Tracer particle velocity magnitude at the inner confinement layer.....	28
Figure 21. Tracer particle velocity magnitude at the outer confinement layer.....	28

INTENTIONALLY LEFT BLANK.

List of Tables

Table 1. Simulations and component masses	29
---	----

INTENTIONALLY LEFT BLANK.

1. Introduction

This study was an exploratory investigation to assess the ballistic performance of a dual confinement warhead. Thus, a series of three computational studies using the CTH hydrocode was performed on a shaped charge device with a double confinement, i.e., two confinement layers with a high explosive fill between them. This concept was presented by Walters and Segletes [1]. As shown in Figure 1, from Walters and Segletes [1], the two confinement layers are depicted as 12 and 21, 3 represents the shaped charge liner, and 7 and 15 are the explosive fills. The design objectives for the device were to maintain the shaped charge performance while allowing dual waves of fragments from the expanding confinement casings. The confinement casings can be of the same or dissimilar materials and the high explosive fills between the inner and outer casing and between the inner casing and the liner can use the same or different explosives. For the case studied numerically, a simple copper liner configuration was used—the inner confinement case was copper, and the outer confinement case was steel. Octol 78/22 was used as the explosive fill throughout. The baseline case used a standard 42° copper liner with a 2.5-mm uniform wall thickness and a 100-mm outer diameter. The outer steel confinement for the baseline case was 7 mm thick and no inner confinement was used. This baseline case provided initial jet characteristics and subsequent improvements were evaluated against this baseline case. The baseline case is simply the same configuration as the dual confinement case with the inner confinement replaced with explosive. The criteria for performance was based on maintaining the jet tip velocity, although it is recognized that the dual confinement layers may alter the jet breakup time and thus alter any performance increase or decrease claims. The simulations were conducted out to a maximum time of 60 μ s.

Prior to conducting runs to optimize the geometry of Figure 1, efforts were made to reduce the overall dual case diameter to be close to the final outer diameter of the baseline case in order to provide a valid comparison based on overall warhead diameter. Then, based on the minimal overall diameter, two cases were considered for the inner confinement, essentially a uniform thickness and a variable thickness inner confinement casing. Initiation times were varied for the two explosive fills. Finally, a wave shaper design is presented to allow one detonator to be used in any planned experiment in order to achieve the two different initiation times. Preliminary studies involved different constitutive models and equations of state used in the simulations. The computational results indicate that the concept is indeed viable, dual fragmenting cases are formed and the shaped charge performance, based on jet tip velocity and velocity gradients, is not diminished. In fact, a slight improvement is realized for some configurations.

The simulations were performed using the CTH hydrocode [2], which is a state-of-the-art, second-order accurate, Eulerian hydrocode developed by Sandia National Laboratories and is capable of solving complex problems in shock physics in one, two, or three dimensions. The

code provides several constitutive models, including an elastic-perfectly plastic model with provisions for work hardening and thermal softening, the Johnson-Cook model [3], the Zerilli-Armstrong model [4], the Steinberg-Guinan-Lund model [5, 6], an undocumented power-law model, and others. High explosive detonation can be modeled using the programmed burn model, the Chapman-Jouguet volume burn models, or the history variable reactive burn model [7]. Several equation of state (EOS) options are available, including tabular (i.e., SESAME), analytical (ANEOS), Mie-Grüneisen, and Jones-Wilkins-Lee (JWL) [8]. Material failure occurs when a threshold value of tensile stress or hydrostatic pressure is exceeded. In addition, the Johnson-Cook failure model [9] is also available. When failure occurs in a cell, void is introduced until the stress state of the cell is reduced to zero. Recompression is permitted. To reduce the diffusion typically encountered in Eulerian simulations, several advanced material interface tracking algorithms are provided, including the high-resolution interface tracking (HRIT) algorithm (available for two-dimensional simulations only), the simple line interface calculation (SLIC) algorithm [10], and the Sandia-modified Youngs' reconstruction algorithm (SMYRA) [11].

2. Problem Setup

Three series of simulations were performed to investigate the merits of dual confined liners. The series are summarized in Table 1. Table 1 also includes the masses of the shaped charge components as well as the total mass for the shaped charges. Some of the shaped charges had a stainless steel base plate for additional confinement at the base of the charge to prevent early release of the detonation products. The input decks from the labels shown in Table 1 are listed in Appendices A–O. The series 1 double confinement simulations all had a variable thickness inner confinement—thick at the base and thin at the apex. The dual confinement shaped charge performance was compared to the performance of their single confinement counterparts. The first simulations (Shpdbl1 and Shpsgl2) had truncated cones for the outer confinement geometry. The outer confinement was changed to a full cone for the remainder of the series 1 simulations. The steel base plate confinement ring as well as the outer confinement was modeled using 301 stainless steel using CTH library values for the Steinberg-Guinan-Lund constitutive model. The inner confinement and shaped charge liner were modeled using standard Johnson-Cook constitutive model parameters for copper for all simulations in series 1 except for Shpdbl5 in which copper was modeled using the strain-rate-independent Steinberg-Guinan-Lund constitutive model. All metals in the series 1 simulations used the SESAME tabular EOS for copper and stainless steel. The explosive was modeled using the standard JWL EOS values for 78/22 Octol.

The series 2 simulations used the same material parameters for the constitutive models and EOS for the respective materials as used in series 1, with the exception that the strain-rate-independent Steinberg-Guinan-Lund constitutive model was used for copper for the

entire series. The series 3 simulations used the standard Johnson-Cook constitutive parameters for copper. The Mie-Grüneisen EOS was used for all metals in the series 3 simulations using standard CTH library values for copper and iron for modeling copper and stainless steel, respectively.

All simulations used a two-dimensional cylindrical coordinate mesh consisting of 208×1020 cells. Both the cells in the axial and radial directions had a cell size of 0.5 mm throughout the entire computational mesh. A simple programmed burn model was used to model the detonation of the explosives. The origin of the coordinate system for all simulations was located at the front of the shaped charge and a Lagrangian tracer particle was placed at -10 cm to capture the jet tip velocity.

3. Results and Discussion

3.1 Series 1 Simulations

Figure 2 shows the geometries for the series 1 simulations with the names of their corresponding input decks as shown in Table 1. The first dual confinement liner (Shpdbl1) and baseline (Shpsgl2) simulations had truncated cones for the outer confinement, as shown in Figures 2a and 2b, respectively. The outer confinement in these simulations had a uniform thickness of 7.315 mm. The outer confinement was changed to a full cone for later simulations in this series (Figures 2c and 2d) while maintaining the same outer confinement thickness of 7.315 mm. The dual confinement shaped charge simulations with a full cone outer confinement, Shpdbl3 and Shpdbl5, share the same geometry (Figure 2c). For the Shpdbl5 simulation the Johnson-Cook strength model for copper, used in all other series 1 simulations, was replaced with a strain-rate-independent Steinberg-Guinan-Lund strength model. The wall thickness of the inner copper confinement layer is tapered such that its thickness increases away from the apex of the confinement. The inner confinement thickness was 2.42 mm at the apex and 3.63 mm at the base. As mentioned earlier, to capture the jet tip velocity, a Lagrangian tracer particle was inserted in the shaped charge liner 10 cm inward from the base of the charges. The complete geometry can be obtained from the CTH input decks given in Appendices A–E.

Figure 3 shows a comparison of the jet tip velocity as a function of time for all series 1 simulations. The figure shows no significant difference in the jet tip velocities for the dual confinement simulations (Shpdbl1, Shpdbl3, and Shpdbl5) or the single confinement baseline simulations (Shpsgl2 and Shpsgl4) other than a time shift due to an earlier detonation wave arrival time for the cases with truncated cone outer confinements (Shpdbl1 and Shpsgl2). The figure shows an increased jet tip velocity (8.2 km/s) for the dual confinement shaped charges over the baseline (7.8 km/s) single confinement shaped charges. There is no significant

difference in jet tip velocity as a result in the change of the copper constitutive models for simulations Shpdbl3 and Shpdbl5.

Figure 4 shows density plots for simulations Shpdbl3 and Shpsgl4 at 20 and 60 μ s. The progress of the detonation wave(s) at 20 μ s can be seen as a density change in Figures 4a and 4b for the dual confinement and baseline shaped charges, respectively. In Figure 4a, the second detonation wave just crosses the apex of the shaped charge liner while the initial detonation wave is at about the same location as the baseline shown in Figure 4b. At 60 μ s (Figure 4c), the dual confinement simulation shows vaporization at the jet tip as evidenced by the low-density purple shape similar to the home plate on a baseball field or resembling an umbrella in three dimensions. Figure 5 shows the formation of a jet from a standard 66-mm Viper shaped charge [12]. The SESAME EOS allows phase transformations and may partially account for the jet tip appearance. On the other hand, if the jet tip halo or umbrella shown in Figure 5 is due to ablation, it should be noted that air was not included in the problem setup. The baseline shaped charge at 60 μ s (Figure 4d) also shows some vaporization near the jet tip but not to the extent seen in the dual confinement simulation. This may be, at least in part, due to the higher tip velocity for Shpdbl3.

Figure 6 shows the pressure profiles at 20 and 40 μ s for simulations Shpdbl1 and Shpsgl2. The plots show pressure along the axis of symmetry of the jets as a function of position at a specific time. The dashed lines in the figure represent the material interfaces at the tip and tail of each jet. It was believed that dual confined shaped charges would experience higher pressure than their baseline counterparts leading to a higher tip velocity. This, however, was only the case at 20 μ s (Figure 6a) where the pressure in the jet formation is higher than the baseline (dual confinement case is shown in black). At 40 μ s (Figure 6b), the pressure is clearly higher in the baseline shaped charge jet. For the simulations, full restart dumps were only performed every 10 μ s of simulation time. Full restart dumps allow the plotting of flow field variables for a particular simulation. Since only certain "snapshots" in time were examined, a complete pressure history is not available. However, at only one snapshot was the pressure in the dual confinement case higher than its baseline. Thus, pressure profile plots are not included for the series 2 and 3 simulations, since they essentially show the same behavior.

Figure 7 shows the axial velocity profiles at 20, 40, and 60 μ s for simulations Shpdbl1 and Shpsgl2. The dual confinement shaped charge jet is shown in black and its baseline is shown in green. The dashed lines again represent the material interfaces at the tip and tail of the jets. The plots represent velocity along the axis of the jet as a function of position at a specific time. At 20 μ s (Figure 7a), the tip of baseline jet is clearly traveling much faster than the dual confinement shaped charge jet. By 40 μ s (Figure 7b), the dual confinement jet's tip velocity exceeds that of its baseline, but the position of the tip lags the baseline. At 60 μ s (Figure 7c), the tip of the jet from the dual confinement simulation has caught up to that of the baseline. Also note that the velocity profiles are different. Simulations discussed later in this report suggest that there is a "double ramp up" in jet tip velocity for dual confinement jets.

The axial velocity as function of position at $60 \mu\text{s}$ for all series 1 dual confinement simulations is shown in Figure 8. The figure shows virtually identical axial velocity profiles for all series 1 dual confinement simulations, with the exception of Shpdbl1, which is offset due to a shorter detonation arrival time due to having a truncated cone for the outer confinement. In summary, there is no significant effect to having a fully confined (full cone) or partially confined (truncated cone) outer confinement. There is also no significant effect as a result of using either the Johnson-Cook or Steinberg-Guinan-Lund strength model for copper.

3.2 Series 2 Simulations

Figure 9 shows the geometries of the shaped charges for the series 2 simulations as well as the corresponding input deck names. Again, the drawings are not fully dimensioned but the full geometry for a specific shaped charge can be obtained by consulting the input decks given in Appendices F–K. The starting geometries for the dual confinement and baseline shaped charge simulations were intentionally chosen to be similar to the initial series 1 simulations as shown in Figures 9a and 9b, respectively. The main difference is that the inner confinement has a constant thickness of 3.5 mm in this series. The outer confinement has a constant thickness of 7 mm. For simulations Billdbl2 (Figure 3c) and Billsgl2 (Figure 4d) an attempt was made to reduce the mass of the initial simulations in this series while maintaining performance. The inner and outer confinement for the Billdbl2 and outer confinement on its baseline, Billsgl2, have a variable thickness, namely, they are thicker toward the apex of the cone. The thickness of the outer confinement is 6.268 mm at the apex and 3.519 mm at the base, and the thickness of the inner confinement is 3.350 mm at the apex and 1.755 mm at the base. The final two simulations in this series, Billdbl3 and Billdbl4, share the same geometry as shown in Figure 9e and the same baseline as in Figure 9b. In these two simulations, the cone angle of the inner confinement was changed from the starting configuration (Figure 9a) but like that simulation has a constant confinement thickness of 3.5 mm. The difference between the Billdbl3 and Billdbl4 simulations was the initiation time for the inner explosive fill.

Figure 10 compares the jet tip velocities of the initial full conical outer confinement dual confinement and baseline shaped charges from series 1 (Figures 2c and 2d) to the initial configurations used in series 2 (Figures 9a and 9b). In other words, Figure 10 compares the effect of having a constant wall thickness inner confinement to that of a tapered wall thickness inner confinement. It can be seen that the jet tip velocity is less for the constant wall thickness inner confinement, Billdbl1, which is expected due to more mass at the apex of the inner confinement. Also, the constant thickness inner confinement simulation shows the jet tip velocity ramps up in two phases (the light blue line). This is an interesting alteration of the jet tip velocity profile. It is possible that this velocity ramp occurs in all dual confinement shaped charges but is not observed because it occurred before the jet tip caught up to the tracer used to record the data.

Figure 11 shows a comparison of the jet tip velocity for all series 2 simulations. From the figure it can be seen that all dual confinement simulations, except for Billdbl3 (light blue line), show a two-step ramp up to the final jet tip velocity. As mentioned previously, simulations Billdbl3 and Billdbl4 differ only in the detonation time for the inner explosive fill. Also in Figure 11, one can see that the two baseline simulations (Billsgl1 and Billsgl2) have approximately the same jet tip velocity. The Billdbl2 reduced mass simulation displays the lowest jet tip velocity in the group, but it also had the least amount of explosive (see Table 1). The Billdbl3 simulation behaves much like a baseline simulation because the initial detonation wave was only slightly beyond the second detonation point at the time of initiation, yet it maintains a jet tip velocity close to the Billdbl1 simulation. Thus, the relative location of the detonation waves is critical.

Figure 12 shows the detonation wave locations at the time the inner explosive fill initiation takes place. It can be seen that for the Billdbl3 simulation the initial detonation wave is very near to the location of the inner detonation point at time of detonation, thus causing it to behave more like the single confinement baseline simulation.

Figure 13 compares density plots for all series 2 simulations that share the same baseline (Billsgl1 in Figure 9b) at 20 and 60 μs . In the plots at 20 μs , the detonation front locations show up as density discontinuities (greenish in the explosive). For the simulations Billdbl1 and Billdbl4, the second detonation wave is just slightly beyond the apex of the shaped charge liner (Figures 13a and 13e, respectively). The second detonation wave is almost even with the initial detonation for simulation Billdbl3 (Figure 13c) at 20 μs . At 60 μs , the density plots for the Billdbl1 (Figure 13b) and Billdbl4 (Figure 13f) simulations have similar vaporization occurring at the jet tip, while the vaporization seen for Billdbl3 (Figure 13d) resembles that observed in baseline shaped charges. The vaporization occurring may be due to an artifact of the SESAME EOS as discussed earlier.

The velocity profiles of these dual confinement simulations are shown with their baseline (Billshp1 in Figure 9b) in Figure 14. The plot shows axial velocity as a function of position along the axis of the jet at 60 μs , and the vertical dashed lines represent material interfaces at the tip and rear of the jets. It can be seen that there is not much difference in the general shape of the velocity profiles at 60 μs . Even for dual confinement simulation where the two detonation waves move nearly in tandem, Billshp3 shows a velocity profile that is closer to that of the other two dual liner profiles instead of the baseline. The baseline has a higher velocity profile near the tip and lower toward its base.

A comparison of the velocity profiles at 60 μs for the Billdbl1 and Billsgl1 simulations to the reduced mass Billdbl2 and Billsgl2 simulations is shown in Figure 15. Again the dashed lines represent the material interfaces at the tip and rear of the jet. While the shaped charge liner was identical in the simulation, there is an offset at the rear due to the reduced size of the steel cover confinement at the base of the liner. The inner confinement in the reduced size simulations was tapered such that it is thicker towards the apex of the confinements. The reduction in size

resulted in less explosive (see Table 1) in the dual confinement Billdb12 simulation as well as its baseline Billsgl2 simulation when compared to the full-size simulation counterparts for simulation Billdb11 and Billsgl1. The Billdb12 and Billsgl2 have a lower velocity over much of their length when compared to their full-size counterparts.

3.3 Series 3 Simulations

The geometries for the final series of simulations, series 3, are shown in Figure 16. The simulations in this series differ from all previous simulations in that the Mie-Grüneisen EOS was used for all metals. Copper was modeled using standard CTH library values for the Mie-Grüneisen EOS as well as standard library values for the Johnson-Cook constitutive model. The stainless steel confinement used standard Mie-Grüneisen values for iron for the EOS and used the CTH library values using the Steinberg-Guinan-Lund constitutive model for 304 stainless steel. Since the Mie-Grüneisen EOS does not include phase changes, as does the SESAME tabular EOS used in the prior simulations, vaporization of the jet tip was not observed. For this series, tracer particles were included in the confinement layers to estimate the velocities of the fragments generated from the confinement layers. The previous simulations imply that the main charge is not adversely affected by the inner confinement. Next, the fragmentation of the inner confinement will be investigated. The locations of the tracers are shown in red in Figure 16. In this series, an attempt was made to reduce the overall mass of the shaped charges. The first simulation in the series, Newshp1 in Figure 16a, was conducted without a baseline since it represented only an intermittent step prior to further mass reduction. Newshp1 also has a variable thickness inner confinement that is thinner toward the apex than at the base. The inner confinement had a thickness of 2.420 mm at the apex and a thickness of 3.439 mm at the base. The outer confinement had a uniform thickness of 7.315 mm. The dual confinement simulation, Newshp2, shown in Figure 16b is the result of the further reduction in mass. The simulation had a constant thickness inner and outer confinement of 3.5 and 7 mm, respectively. The corresponding baseline is shown in Figure 16c. The final simulation of the series, Waveshp2, shown in Figure 16d, was designed to use a wave shaper and a single detonation point. The idea was to use the geometry of Figure 16b to design a shaped charge that would readily facilitate fabrication and testing. The wave shaper was designed so that the detonation wave arrives at the same point and initiates at the same approximate time as the dual explosive initiation simulation, Newshp2. Also the base plate confinement ring was eliminated since it does not influence the jet behavior during the first 60 μ s. The input decks for the series 3 simulations can be found in Appendices L–O.

Data for the tracers used to measure jet tip velocity for the series 3 simulations are shown in Figure 17. The red and light blue curves, representing dual confinement simulations Newshp1 and Newshp2, respectively, both show a two-step “ramping” to achieve the final jet tip velocity. The Waveshp2 simulation (dark blue curve) does not show a ramping effect. However, it is possible that it occurred before the jet tip caught up with the tracer and therefore was not captured. The jet tip velocities for the dual confinement simulations fall in a range of

approximately 8.0 to 8.3 km/s. The single confinement baseline simulation, Newbsl2, has an approximate jet tip velocity of 7.6 km/s.

Density plots for the dual confinement simulations for series 3 are shown in Figure 18. Figures 18a, 18c, and 18e show the density plots for Newshp1, Newshp2, and Waveshp2 at 20 μ s, respectively. In these figures it can be seen that the detonation wave location for the second explosive initiation closely matches that for the dual confinement simulation with a wave shaper and only one initiation point. At 60 μ s (Figures 18b, 18d, and 18f), the dual confinement simulations closely resemble each another.

Figure 19 shows the axial velocity profile along the centerline for the series 3 jets at 30 and 50 μ s. Material interfaces at the tip and rear of the jets are represented with dashed lines. At 30 μ s (Figure 19a), the single confinement baseline jet (green curve) leads the dual confinement simulations. The dual confinement simulations all have a much higher velocity near the jet tip at 30 μ s. At 50 μ s (Figure 19b), the velocity profiles of the dual confinement simulations are virtually identical except near the jet tip, and the early arrival time of the jet tip for the single confinement simulation is diminished.

Figure 20 shows the velocity magnitudes at the location where the Lagrangian tracers were placed on the inner confinement for the dual confinement simulations (see Figure 16). The decline in velocity magnitude is due to the passing of the second detonation wave after the inner liner was first compressed and then expands with the passing of the second detonation wave. This event is very similar for all dual confinement simulations in series 3. At the location of the Lagrangian tracer, the velocity magnitude varied from approximately 680 to 780 m/s. Figure 21 shows a similar plot for velocity magnitude for the outer confinement of all series 3 simulations. Because the single confinement simulation, Newbsl2, has more explosive and no inner confinement resisting expansion, it shows a much greater velocity magnitude than any of the dual confinement simulations in series 3. Simulation Newshp1 and Waveshp2 show surprisingly similar profiles. One might expect the velocity magnitude for Newshp2 to be similar to the Waveshp2 velocity magnitude because the geometry for Waveshp2 was derived from Newshp2; however, Newshp2 shows a lower velocity. Note however, that the charge to mass ratios are different, per Table 1, where Newshp2 has more confinement mass and less explosive mass than Waveshp2.

4. Conclusions

The objective, namely to demonstrate the feasibility of launching dual waves of fragments from a shaped charge with two confinement bodies, was achieved. A dual confinement charge provides a second wave of lethal fragments, which may be useful in certain applications such as multipurpose rounds. The exact geometry, mass, and radial velocity of the two waves of

fragments were not characterized in detail. The performance (i.e., the jet tip velocity) of the main shaped charge was not adversely affected up to 60 μ s after initiation. In fact, some confinement designs (e.g., Shpdbl3 in series 1) show an increase in jet tip velocity, which may lead to enhanced performance. In addition, the velocity profile can be altered to provide a ramp or plateau in the velocity gradient. Finally, experimental verification of this concept should be obtained once the charge/confinement design is optimized since the CTH code simulations prove that the design is viable.

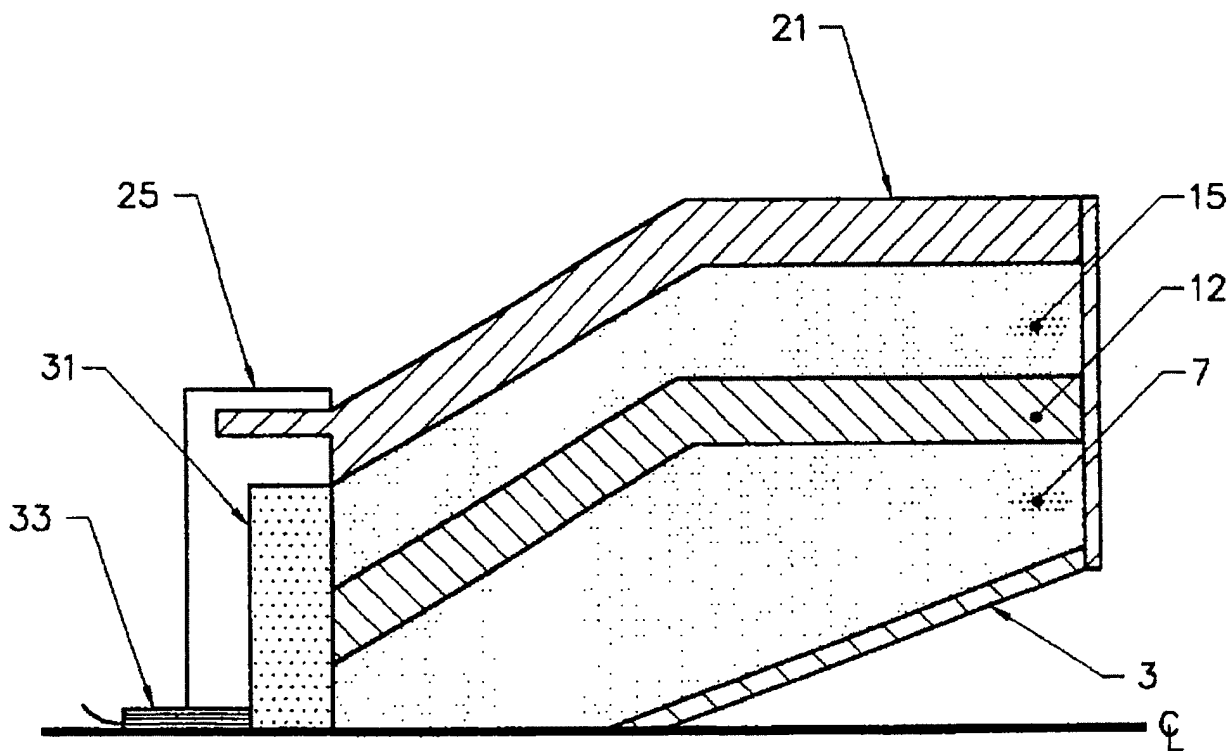
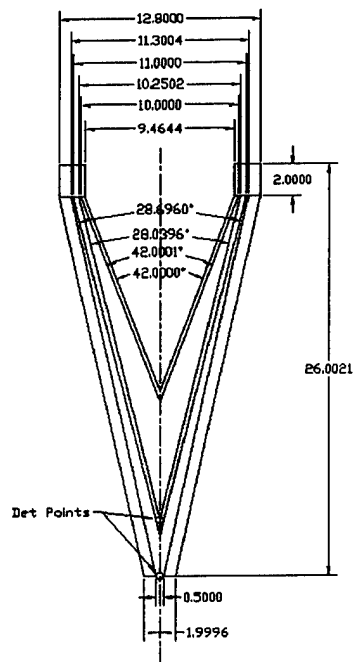
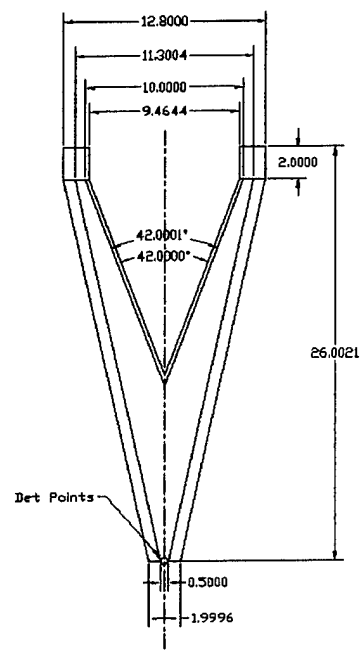

Figure 1. Dual confinement liner patent drawing [1]. The drawing shows an axisymmetric charge where 7 and 15 are explosive fills, 3 is the shaped charge liner, 12 and 21 are the confinement layers, 33 is the detonator, 31 is the booster, and 25 is the centering device.



(a) Shpdbl1



(b) Shpsgl2

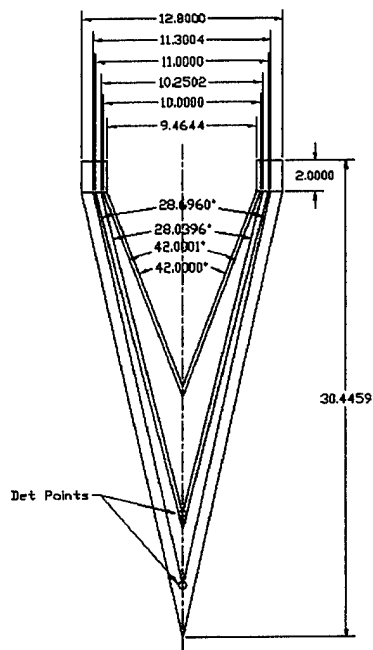

(c) Shpdbl3 and Shpdb15

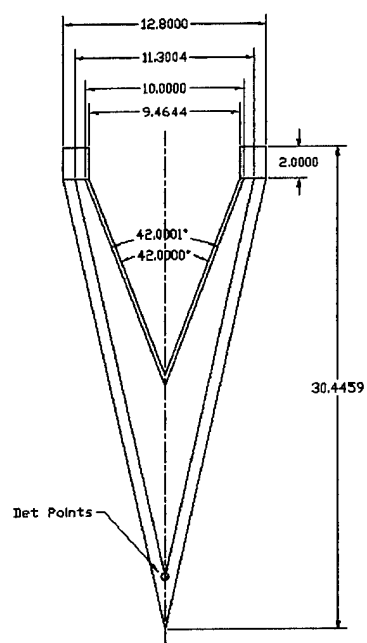

(d) Shpsgl4

Figure 2. Shaped charge geometries for series 1 simulations.

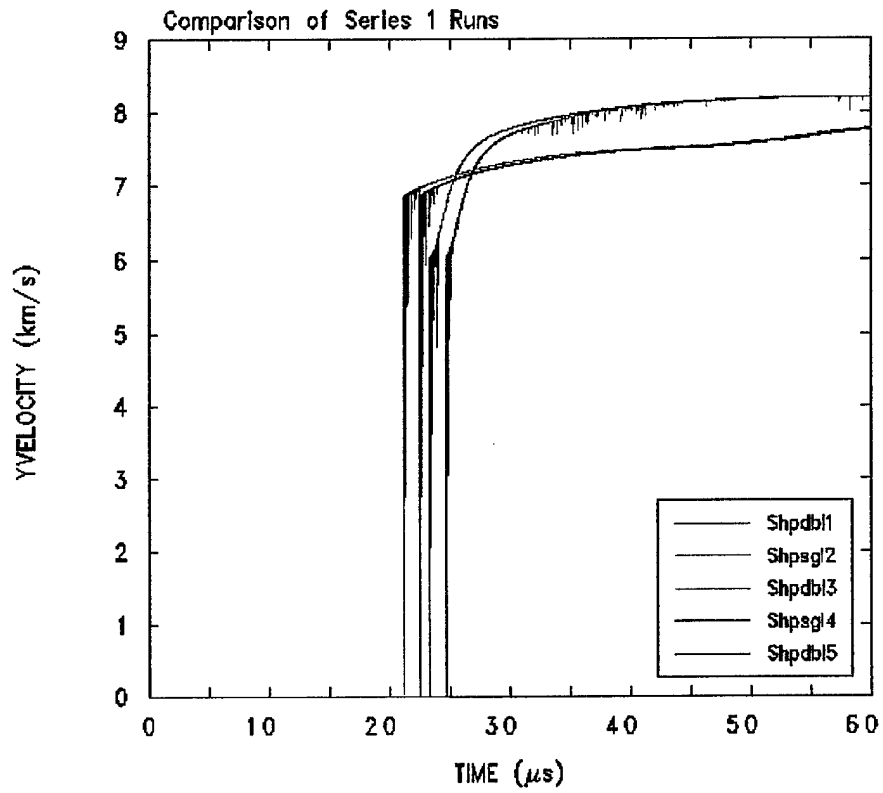
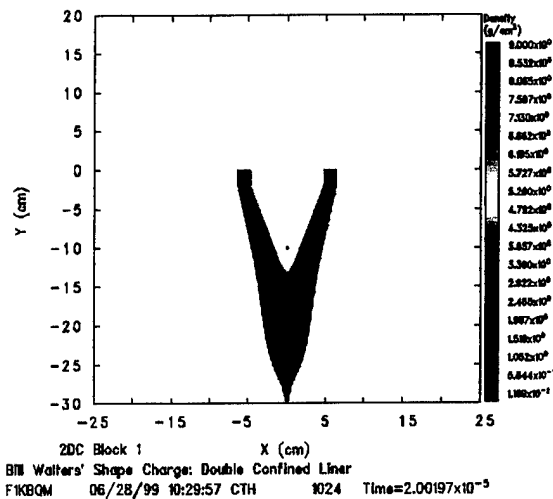
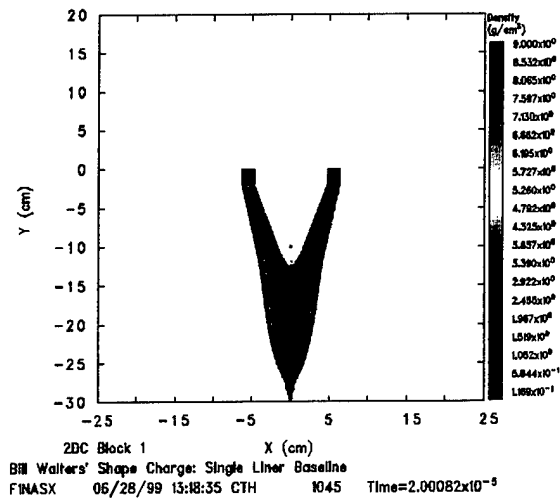

Figure 3. Tracer data showing jet tip velocity for all series 1 simulations.



(a) Shpdbl3 at 20 μs



(b) Shpsgl4 at 20 μs

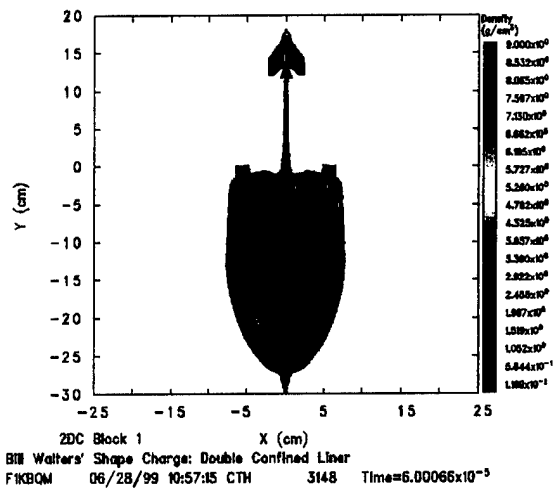

(c) Shpdbl3 at 60 μs

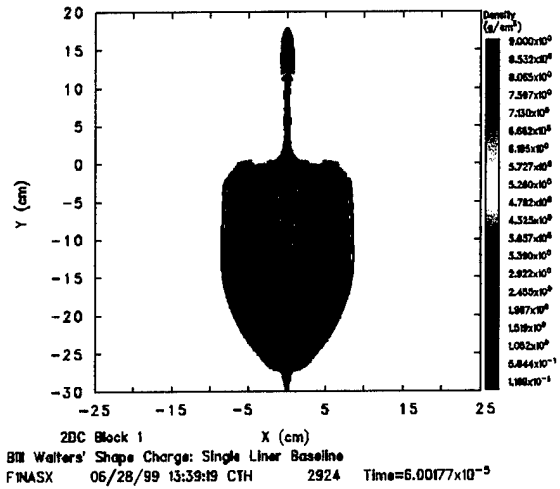

(d) Shpsgl4 at 60 μs

Figure 4. Density plots for simulations Shpdbl3 and Shpsgl4.



Figure 5. Viper 66-mm shaped charge jet at 26.63 μ s [12].

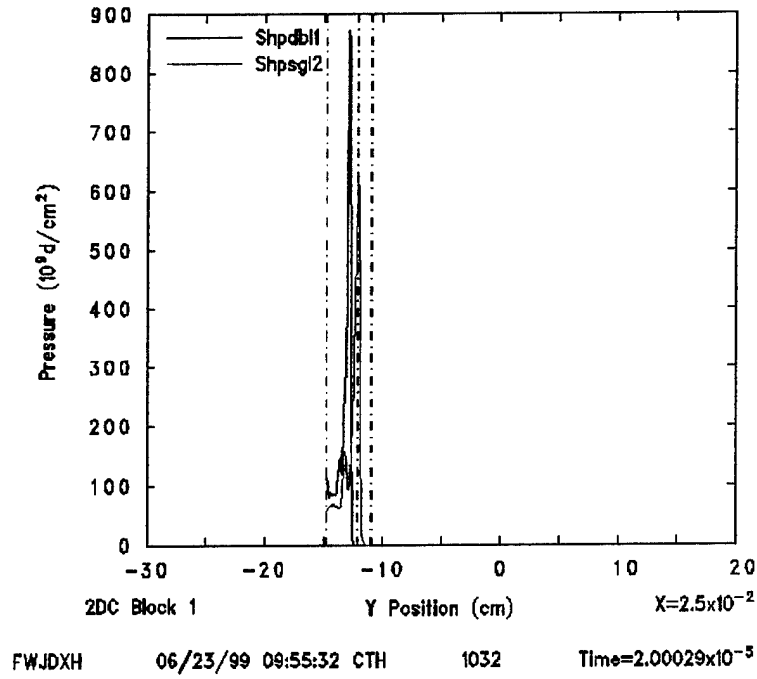

(a) 20 μ s

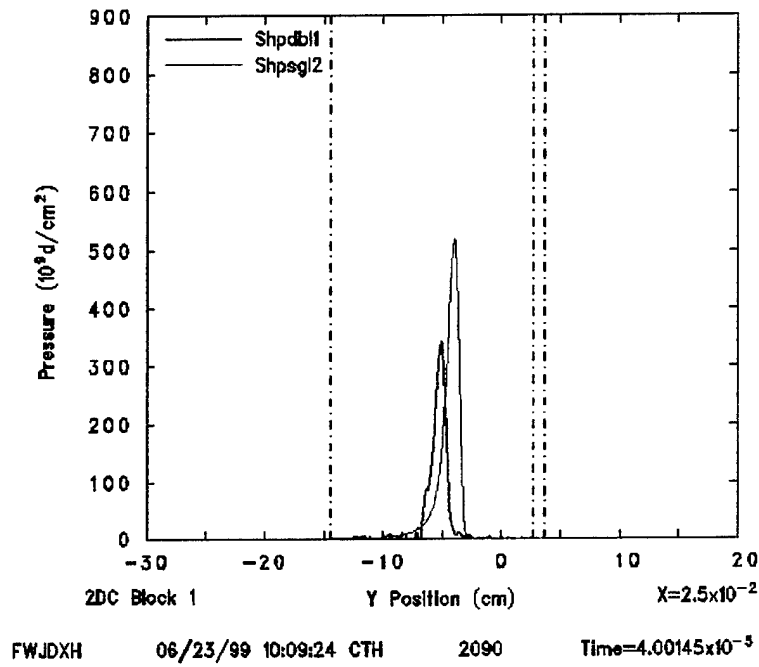

(b) 40 μ s

Figure 6. Comparison of pressures at two times for dual confinement jet and its baseline, Shpdbl1 and Shpsgl2.

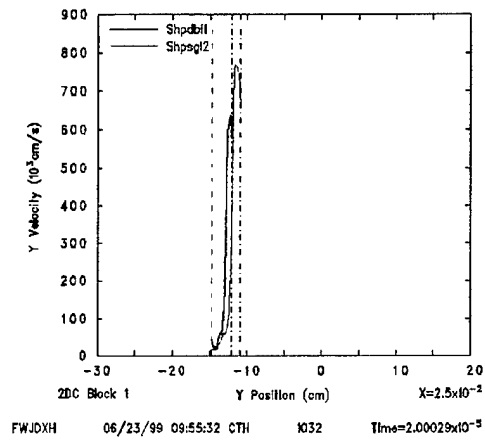

(a) 20 μ s

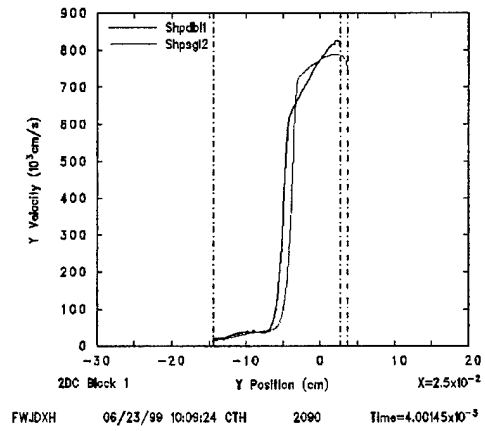

(b) 40 μ s

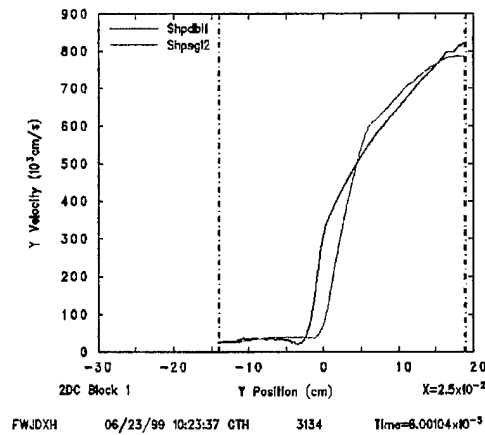

(c) 60 μ s

Figure 7. Comparison of axial velocity profile of dual confinement jet with its baseline.

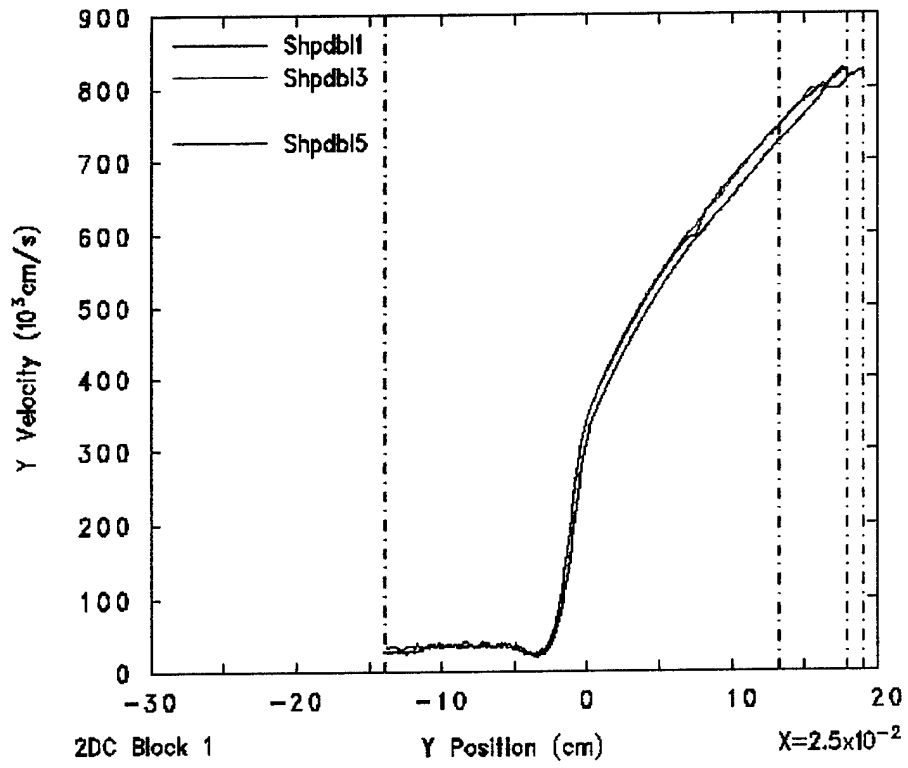

FWJDXH 06/23/99 10:23:37 CTH 3134 Time=6.00104x10⁻⁵

Figure 8. Series 1 dual confined charges axial velocity profiles.

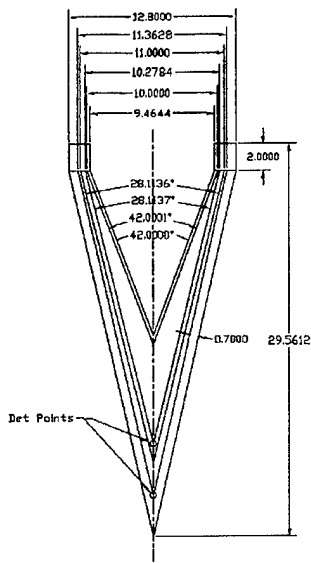

(a) Billdbl1

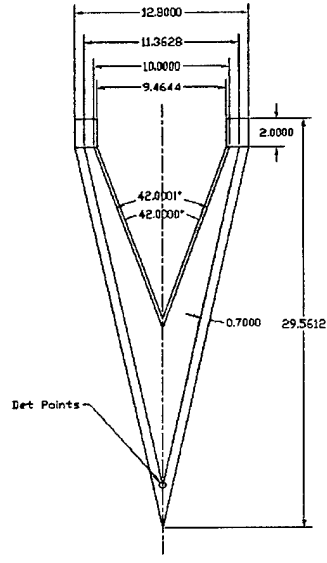

(b) Billsgl1

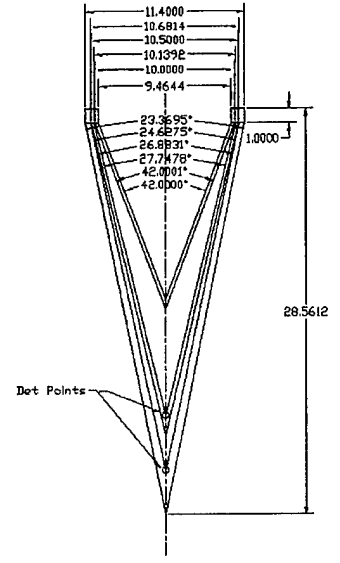

(c) Billdbl2

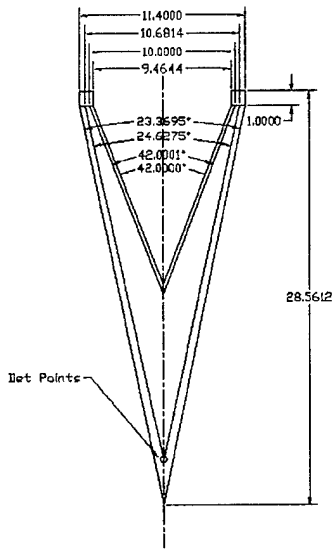

(d) Billsgl2

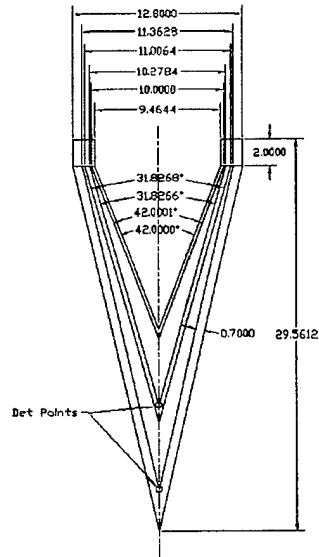

(e) Billdbl3 and Billdbl4

Figure 9. Shaped charge geometries for series 2 simulations.

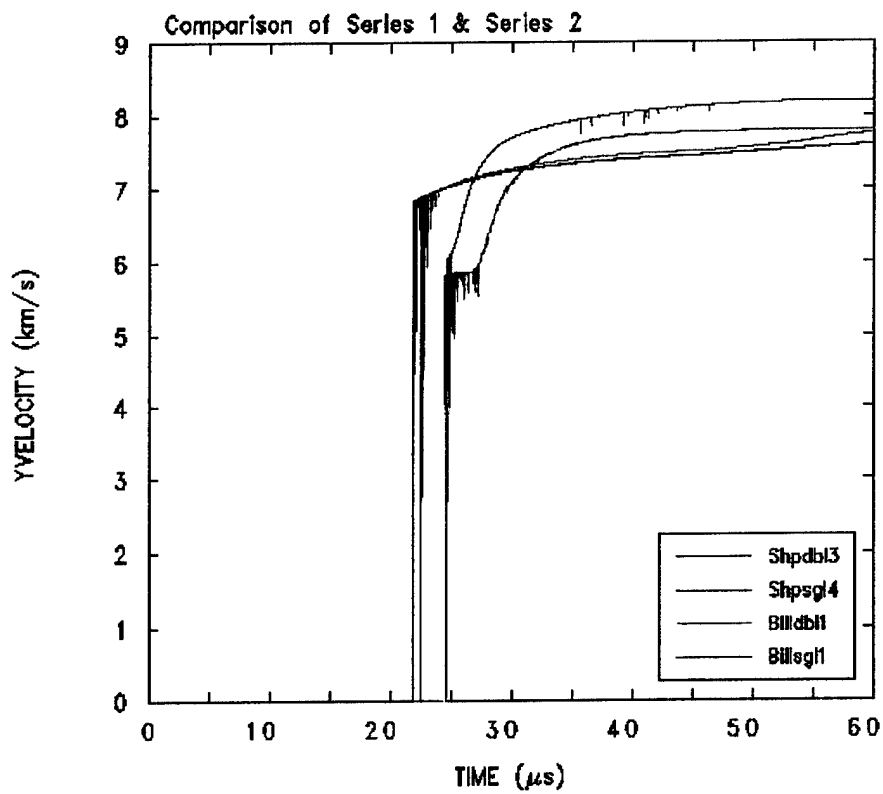

Figure 10. Comparison of series 2 jet tip velocity with series 1 for dual confinement shaped charge and its baseline.

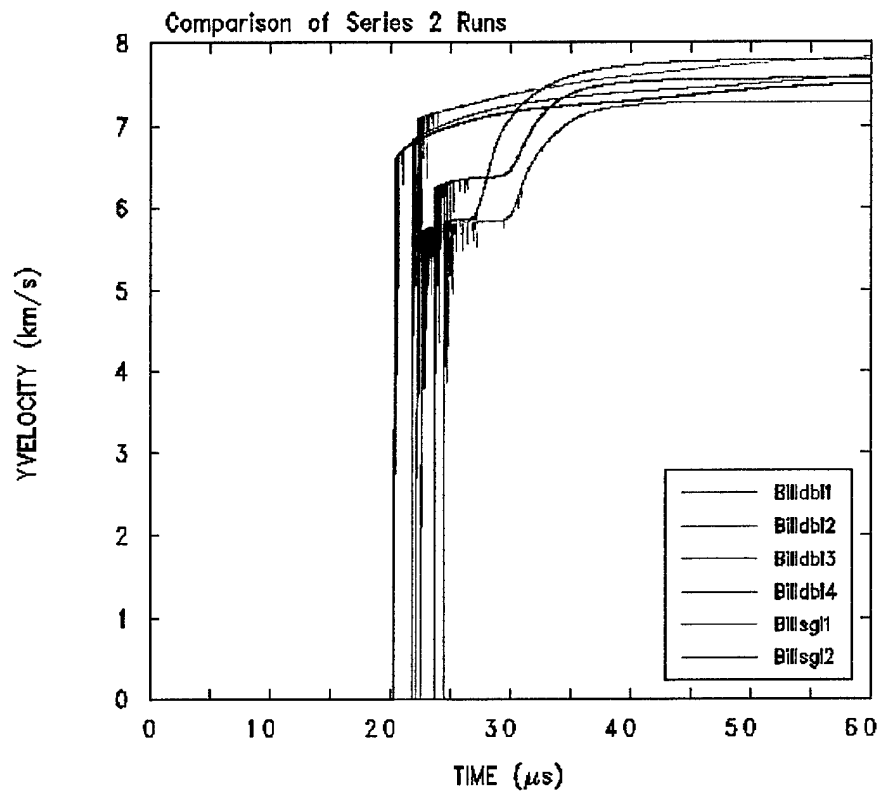

Figure 11. Tracer data showing jet tip velocity for all series 2 simulations.

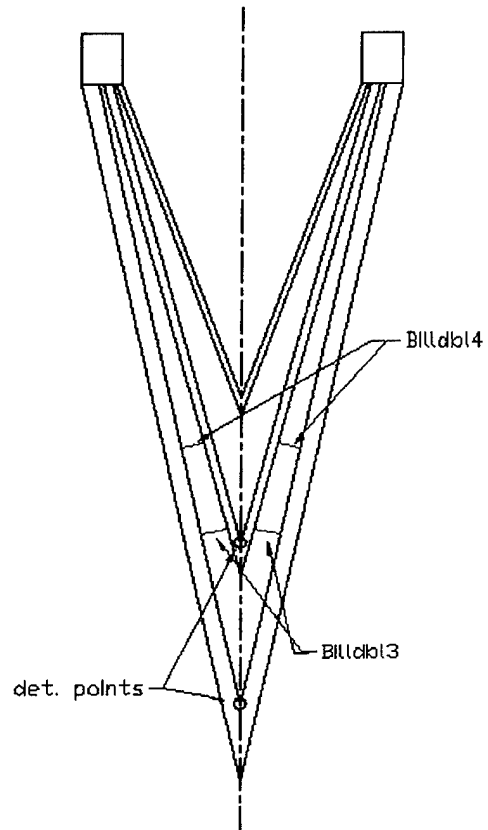
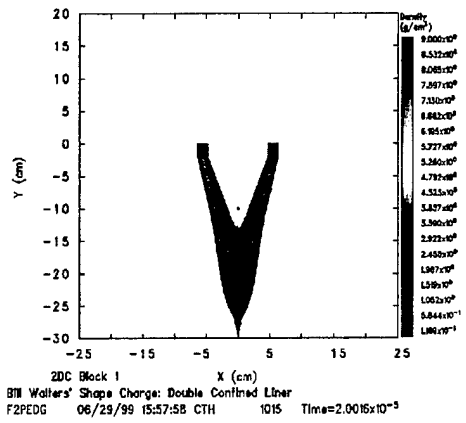
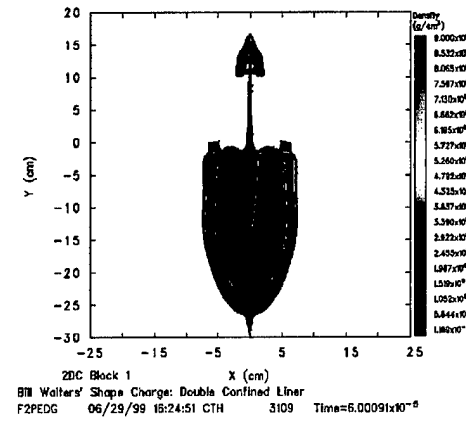

Figure 12. Detonation wave location at the time of inner explosive initiation for Billdbl3 and Billdbl4 simulations.



(a) Billdb11 at 20 μ s



(b) Billdb11 at 60 μ s

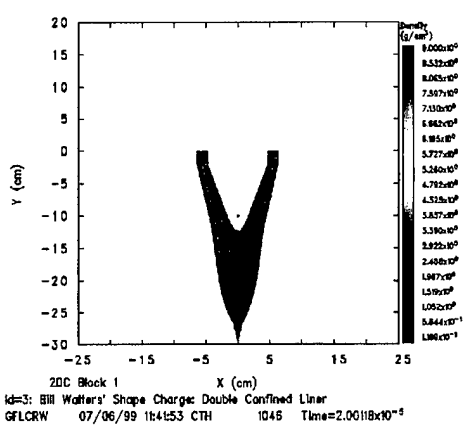

(c) Billdb13 at 20 μ s

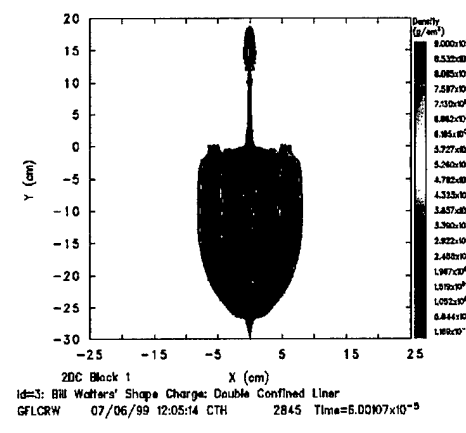

(d) Billdb13 at 60 μ s

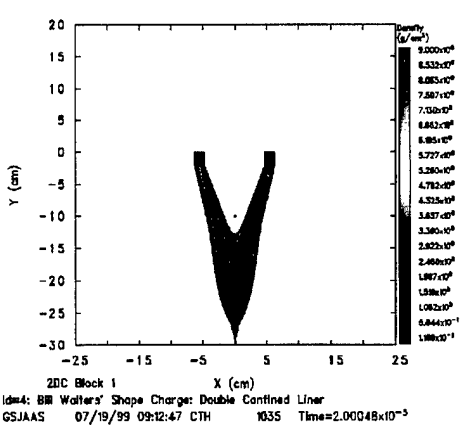

(e) Billdb14 at 20 μ s

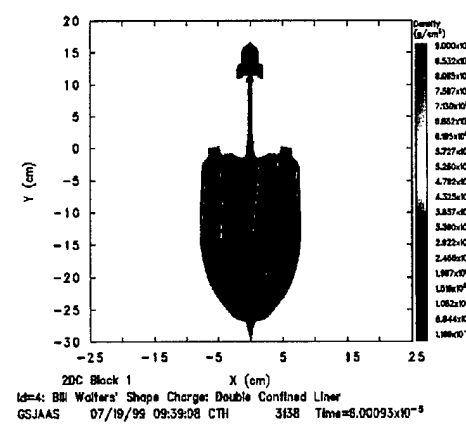

(f) Billdb14 at 60 μ s

Figure 13. Comparison of series 2 dual confinement simulations sharing the same baseline (Billshp1).

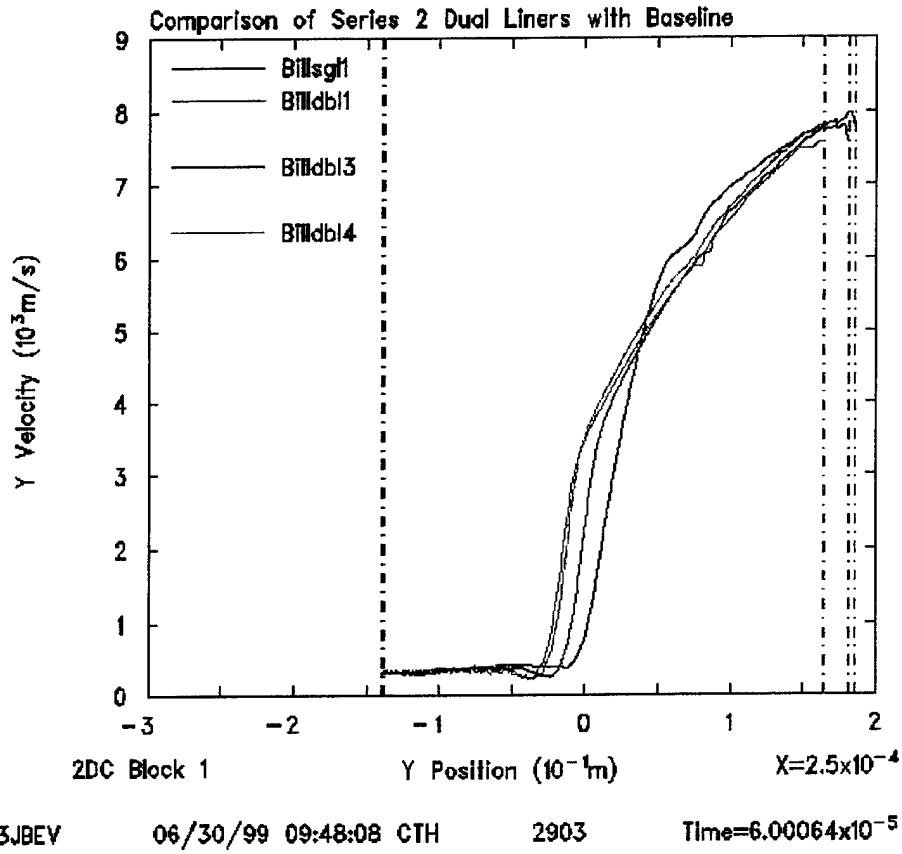
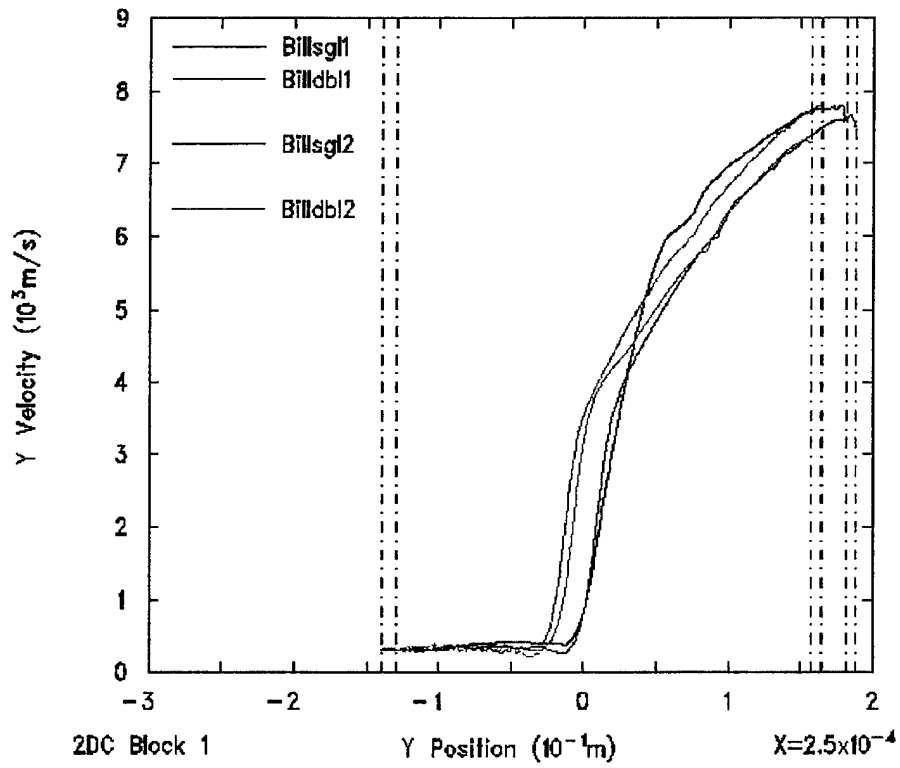
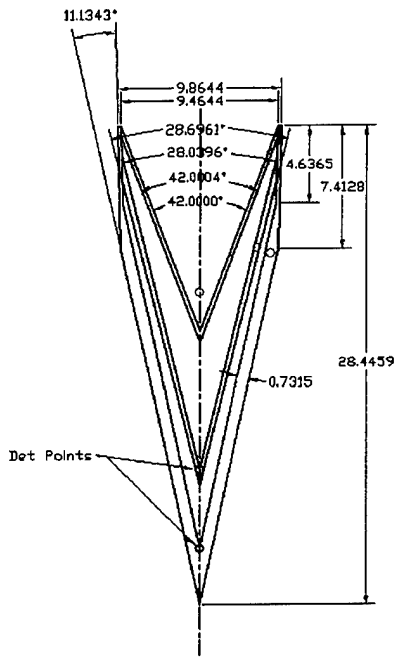

Figure 14. Comparison of series 2 dual confinement simulations sharing a common baseline with the baseline (Billsg11).



F3JBEV 06/30/99 09:48:08 CTH 2903 Time=6.00064x10⁻⁵

Figure 15. Comparison of reduced mass series 2 jet velocity with full-size counterparts.



(a) Newshp1

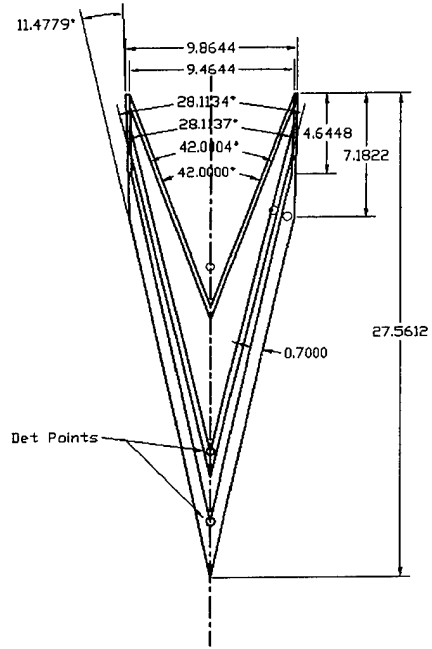

(b) Newshp2

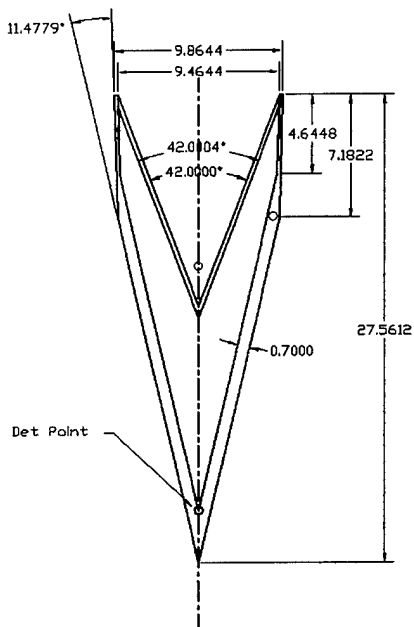

(c) Newbsl2

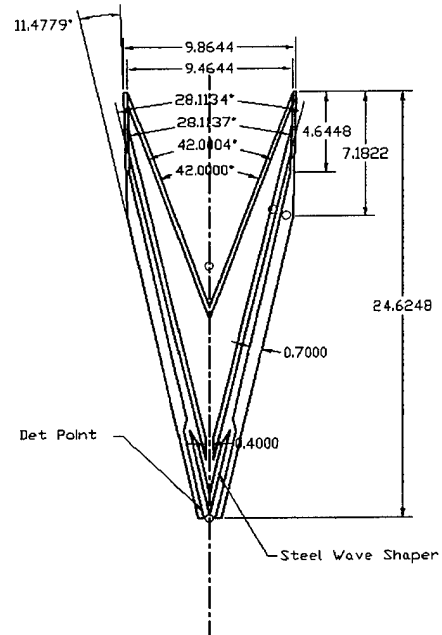

(d) Waveshp2

Figure 16. Shaped charge geometries for series 3 simulations.

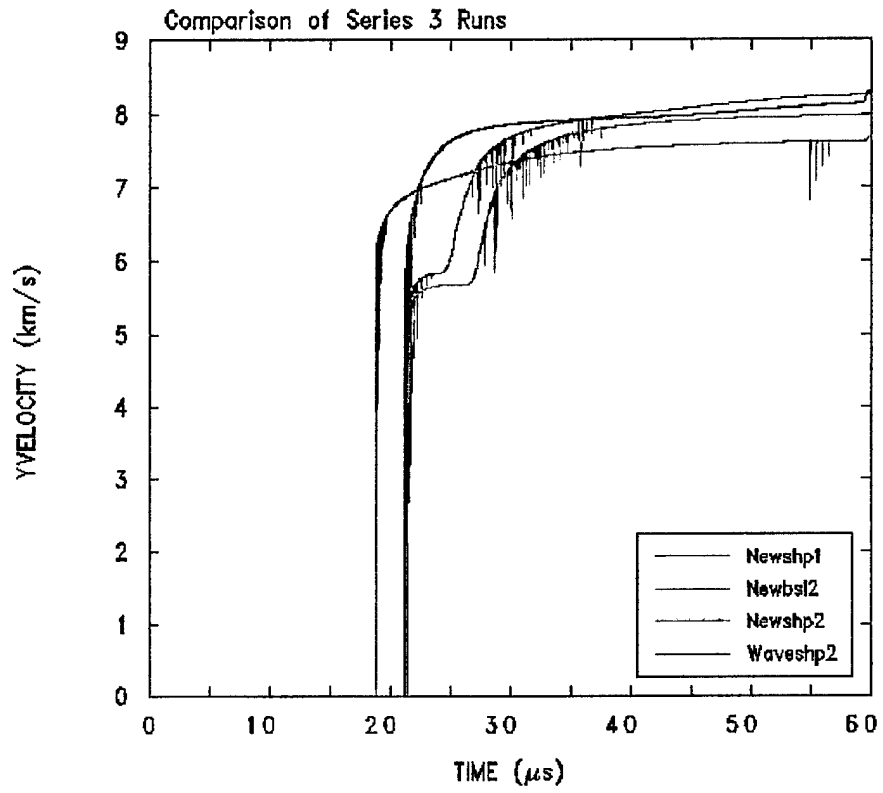
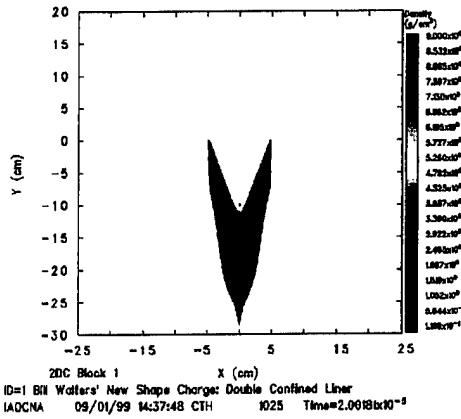
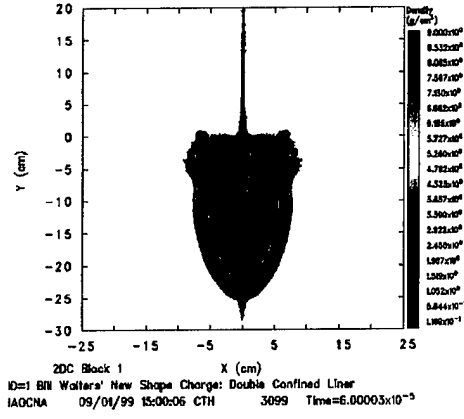

Figure 17. Comparison of jet tip velocity for series 3 simulations.



(a) Newshp1 at 20 μ s



(b) Newshp1 at 60 μ s

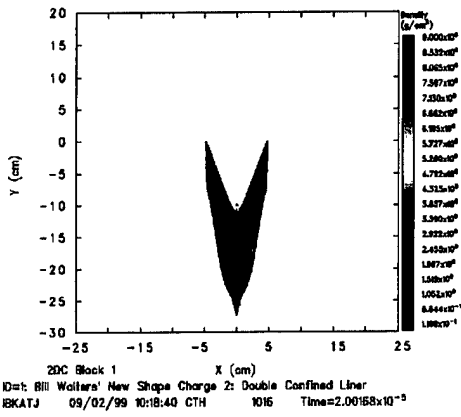

(c) Newshp2 at 20 μ s

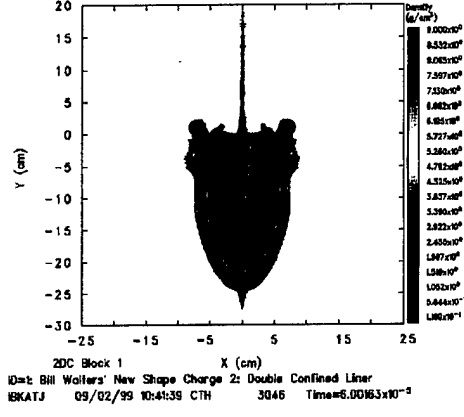

(d) Newshp2 at 60 μ s

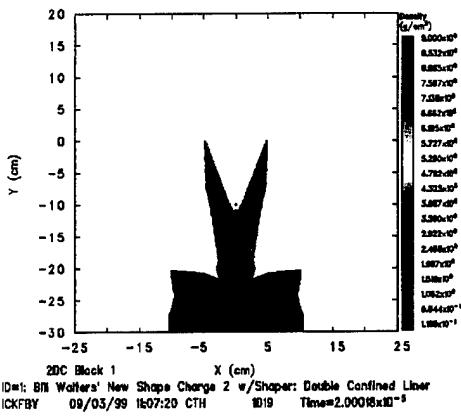

(e) Waveshp2 at 20 μ s

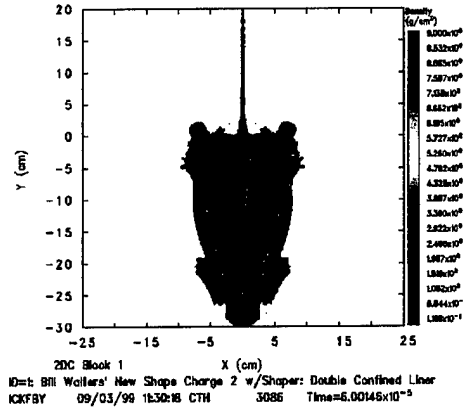

(f) Waveshp2 at 60 μ s

Figure 18. Density plots for series 3 dual confined shaped charges at 20 and 60 μ s.

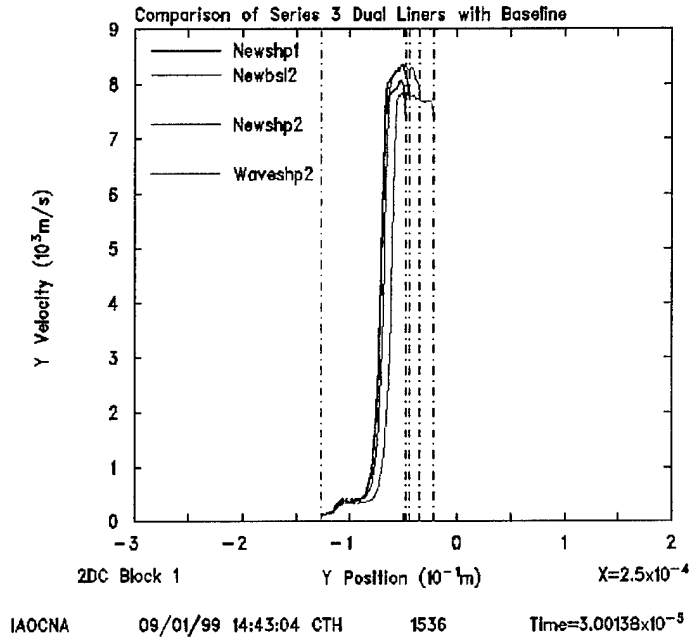

(a) 30 μs

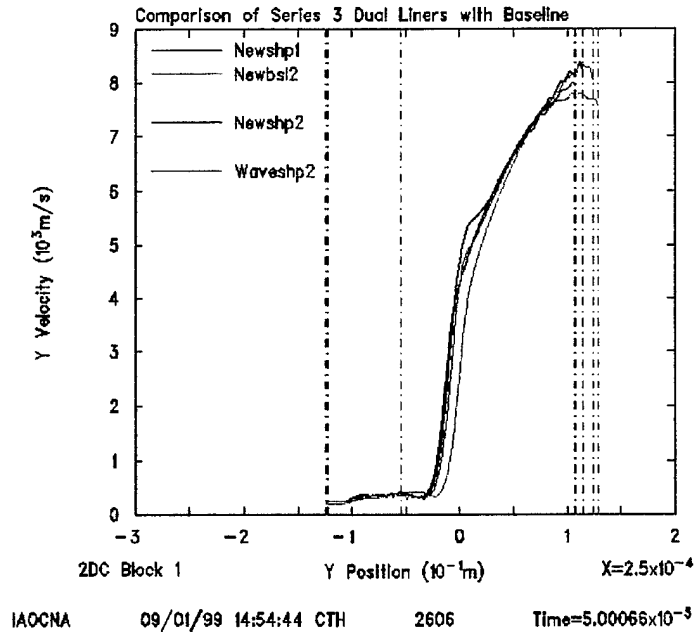

(b) 50 μs

Figure 19. Axial velocity profiles for series 3 simulations at 30 and 50 μs .

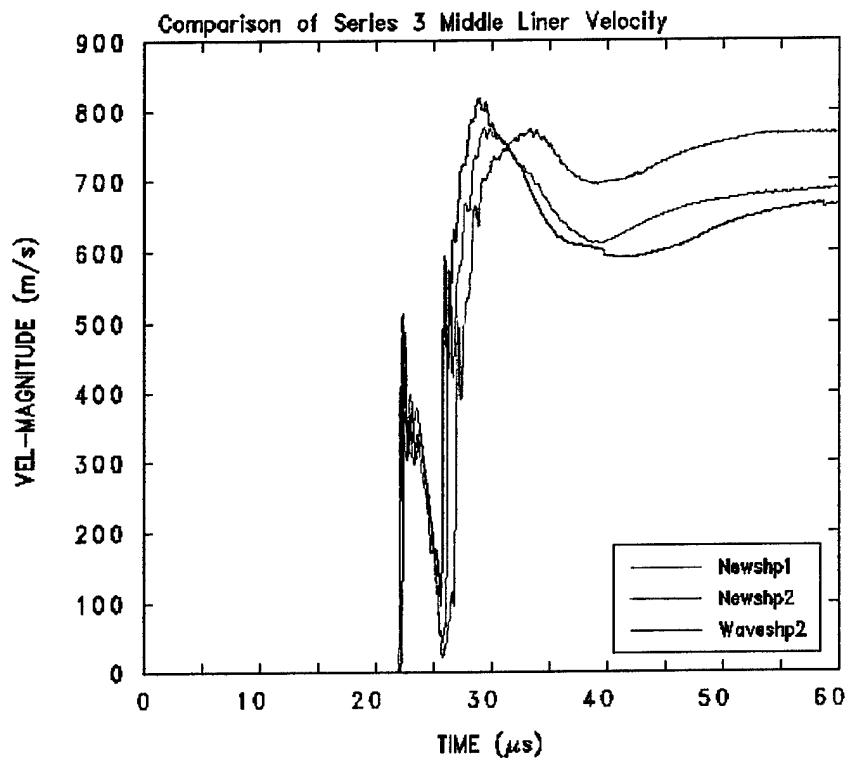

Figure 20. Tracer particle velocity magnitude at the inner confinement layer.

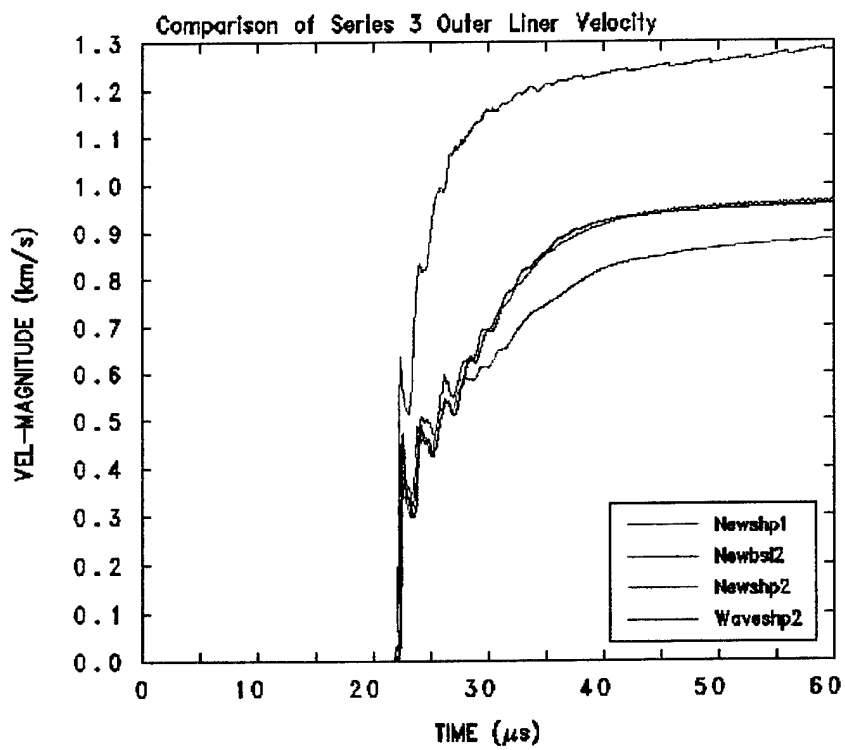

Figure 21. Tracer particle velocity magnitude at the outer confinement layer.

Table 1. Simulations and component masses.

Input Deck	Steel Base Plate Mass (g)	Cu Liner Mass (g)	Inner Cu Confinement Mass (g)	Steel Liner Confinement Mass (g)	Octol Charge Mass (g)	Total Mass (g)
Series 1 Simulations						
Shpdbl1	939	464	1041	3027	696	6167
Shpsgl2	939	464	NA	3027	908	5338
Shpdbl3	939	464	1041	3064	696	6204
Shpsgl4	939	464	NA	3064	908	5375
Shpdbl5	939	464	1041	3064	696	6204
Series 2 Simulations						
Billdbl1	939	464	1144	2859	652	6058
Billsgl1	939	464	NA	2859	885	5147
Billdbl2	255	464	729	1666	561	3675
Billsgl2	255	464	NA	1666	710	3095
Billdbl3	939	464	1015	2859	678	5955
Billdbl4	939	464	1015	2859	678	5955
Series 3 Simulations						
Newshp1	NA	436	777	2075	633	3921
Newshp2	NA	436	877	1940	585	3838
Newbsl2	NA	436	NA	1940	764	3140
Waveshp2	NA	436	820	1880	608	3744

Notes:

Cu = copper.

NA = not applicable.

INTENTIONALLY LEFT BLANK.

5. References

1. Walters, W. P., and S. B. Segletes. "Shaped Charge Devices With Multiple Confinements." U.S. Patent 5,847,312, 8 December 1998.
2. McGlaun, J. M., S. L. Thompson, and M. G. Elrick. "CTH: A Three-Dimensional Shock Wave Physics Code." *International Journal of Impact Engineering*, vol. 10, nos. 1–4, pp. 351–360, 1990.
3. Johnson, G. R., and W. H. Cook. "A Constitutive Model and Data Subjected to Large Strains, High Strain Rates, and High Temperatures." *Proceedings of the Seventh International Symposium on Ballistics*, The Hague, The Netherlands, pp. 541–548, 1983.
4. Zerilli, F. J., and R. W. Armstrong. "Dislocation-Mechanics-Based Constitutive Relations for Material Dynamics Calculations." *Journal of Applied Physics*, vol. 61, no. 5, pp. 1816–1825, 1987.
5. Steinberg, D. J., S. G. Cochran, and M. W. Guinan. "A Constitutive Model for Metals Applicable at High-Strain Rate." *Journal of Applied Physics*, vol. 51, no. 3, pp. 1498–1504, 1980.
6. Steinberg, D. J., and C. M. Lund. "A Constitutive Model for Strain Rates From 10^{-4} to 106 s^{-1} ." *Journal of Applied Physics*, vol. 65, no. 4, pp. 1528–1533, 1989.
7. Kerley, G. I. "CTH Equation of State Package: Porosity and Reactive Burn Models." SAND92-0553, Sandia National Laboratories, Albuquerque, NM, 1992.
8. Lee, E. L., H. C. Hornig, and J. W. Kury. "Adiabatic Expansion of High Explosive Detonation Products." UCRL-50422, Lawrence Livermore National Laboratory, Livermore, CA, 1968.
9. Johnson, G. R., and W. H. Cook. "Fracture Characteristics of Three Metals Subjected to Various Strains, Strain Rates, Temperatures, and Pressures." *Journal of Engineering Fracture Mechanics*, vol. 21, no. 1, pp. 31–48, 1985.
10. Noh, W. F., and P. Woodward. "SLIC (Simple Line Interface Calculation)." *Lecture Notes in Physics*, Springer-Verlag, vol. 59, 1976.
11. Bell, R. L., and E. S. Hertel, Jr. "An Improved Material Interface Reconstruction Algorithm for Eulerian Codes." SAND92-1716, Sandia National Laboratories, Albuquerque, NM, 1992.
12. Baum, D. W., L. L. Shaw, S. C. Simonson, and K. A. Winer. "Liner Collapse and Early Jet Formation in a Shaped Charge." *14th International Symposium on Ballistics*, pp. 26–29, Quebec, Canada, September 1993.

INTENTIONALLY LEFT BLANK.

Appendix A.
Input Deck for Shpdb11 Double Confinement Shaped Charge

This appendix appears in its original form, without editorial change.

INTENTIONALLY LEFT BLANK.

```

*
*eor*cgenin
*
Bill Walters' Shape Charge: Double Confined Liner
*
control
  ep
  mmp
endcontrol
*
mesh
  block geometry 2dc type e
  x0=0.0
  x1 n=208 dxf=0.05 rat=1.
  endx
  y0=-30.0
  y1 n=1000 dyf=0.05 rat=1.
  endy
* xact=0.0,1.0
* yact=0.0,5.0
  endblock
endmesh
*
insertion of material
  block 1
  *
  * NOTE: From of steel cover sit at x-coordinate origin.
  *
  package 'Steel Cover'
  material 1
  numsub 50
  insert uds
  point 4.7322 0.0000
  point 6.4000 0.0000
  point 6.4000 -2.0000
  point 4.7322 -2.0000
  endinsert
endpackage
*
  package 'Main Cu liner'
  material 2
  numsub 50
  insert uds
  point 0.0000 -14.3278

```

```
point 4.7322 -2.0000
point 5.0000 -2.0000
point 0.0000 -15.0254
endinsert
endpackage
```

*

```
package 'Middle Cu liner'
material 3
numsub 50
insert uds
point 0.0000 -22.5254
point 5.1251 -2.0000
point 5.5000 -2.0000
point 0.0000 -23.5021
endinsert
endpackage
```

*

```
package 'Outer Steel liner'
material 4
numsub 50
insert uds
point 0.2500 -26.0021
point 5.6502 -2.0000
point 6.4000 -2.0000
point 0.9998 -26.0021
endinsert
endpackage
```

*

```
package 'Octol Charge'
material 5
numsub 50
insert uds
point 0.0000 -15.0254
point 5.0000 -2.0000
point 5.6502 -2.0000
point 0.2500 -26.0021
point 0.0000 -26.0021
endinsert
endpackage
```

*

```
endblock
endinsertion
```

*

```
epdata
```

```

*
* NOTE: Poisson's Ratio was estimated from  $G=(3*(1-2*\nu))/(2*(1+\nu))*\rho*C**2$ ;
*   where G,  $\nu$ ,  $\rho$ , and C and the shear modulus, Poisson's Ratio,
*   density, and bulk sound speed, respectively. All material parameters
*   except Poisson's Ratio came from Steinberg.
*
matep 1 steinberg 304_ss poisson=0.285  tmelt=0.20509
matep 2 johnson  copper poisson=0.346  tmelt=0.11898
matep 3 johnson  copper poisson=0.346  tmelt=0.11898
matep 4 steinberg 304_ss poisson=0.285  tmelt=0.20509
vpsave
mix 3
endep
*
eos
mat1 sesame st_steel
mat2 sesame user eos=3336 feos='/ha/cta/unsupported/CTH/CTH_9903/data/seslan'
mat3 mat2
mat4 mat1
mat5 jwl  octol78/22
endeos
*
heburn
material 5 d 8.48e5 pre 1.0e12
      dp 0.0000 -26.0021 ti 0.0  radius 0.2
      dp 0.0000 -22.5254 ti 8.0e-6 radius 0.2
endheburn
*
tracer
add 0.0 -10.0
endtracer
*
*eor*cthin
*
Bill Walters' Shape Charge: Double Confined Liner
*
control
tstop=60.e-6
cpshift=900.
rdumpf=3600
ntbad 100000000
endcontrol
*
restart

```

```

cycle=0
endr
*
cellthermo
  mmp1
endcell
*
convct
  convect=1
  interface=high
endc
*
discard
  material 5 density -0.01 pressure 5.0e6 ton 30.0e-6
endd
*
edit
  shortt
    time=0. dtf=10000.
  ends
  longt
    time=0. dtf=10000.
  endl
  plott
    time=0. dtf=1.0e-6
  endp
  plotdata
    volume
    pressure
    velocity
  endplotdata
  restt
    time=0 dtf=10.e-6
  endr
  histc
    cycle=0 dcfreq=1
    htracer1
  endh
endedit
*
mindt
  time=0. dtmin=1.0e-11
  time=20.0e-6 dtmin=1.0e-10
endm

```

```
*
fracts
  pressure
  pfrac1=-25.0e9
  pfrac2=-15.0e9
  pfrac3=-15.0e9
  pfrac4=-25.0e9
  pfrac5= -1.0e-9
  pfmix =-5.0E20
  pvoid=-5.0E20
endf
*
boundary
  bhydro
  block=1
  bxbot 0
  bxtop 2
  bybot 2
  bytop 2
  endb
endh
endb
*
*eor*pltin
*
```

INTENTIONALLY LEFT BLANK.

Appendix B.
Input Deck for Shpsgl2 Single Confinement Shaped Charge

This appendix appears in its original form, without editorial change.

INTENTIONALLY LEFT BLANK.

```

*
*eor*cgenin
*
Bill Walters' Shape Charge: Single Liner Baseline
*
control
  ep
  mmp
endcontrol
*
mesh
  block geometry 2dc type e
  x0=0.0
  x1 n=208 dxf=0.05 rat=1.
  endx
  y0=-30.0
  y1 n=1000 dyf=0.05 rat=1.
  endy
* xact=0.0,1.0
* yact=0.0,5.0
  endblock
endmesh
*
insertion of material
  block 1
  *
  * NOTE: From of steel cover sit at x-coordinate origin.
  *
  package 'Steel Cover'
  material 1
  numsub 50
  insert uds
  point 4.7322 0.0000
  point 6.4000 0.0000
  point 6.4000 -2.0000
  point 4.7322 -2.0000
  endinsert
endpackage
*
package 'Main Cu liner'
material 2
numsub 50
insert uds
point 0.0000 -14.3278

```

```

    point 4.7322 -2.0000
    point 5.0000 -2.0000
    point 0.0000 -15.0254
endinsert
endpackage
*
package 'Outer Steel liner'
material 3
numsub 50
insert uds
    point 0.2500 -26.0021
    point 5.6502 -2.0000
    point 6.4000 -2.0000
    point 0.9998 -26.0021
endinsert
endpackage
*
package 'Octol Charge'
material 4
numsub 50
insert uds
    point 0.0000 -15.0254
    point 5.0000 -2.0000
    point 5.6502 -2.0000
    point 0.2500 -26.0021
    point 0.0000 -26.0021
endinsert
endpackage
*
endblock
endinsertion
*
epdata
*
* NOTE: Poisson's Ratio was estimated from  $G=(3*(1-2*v))/(2*(1+v))*rho*C**2$ ;
* where G, v, rho, and C and the shear modulus, Poisson's Ratio,
* density, and bulk sound speed, respectively. All material parameters
* except Poisson's Ratio came from Steinberg.
*
matep 1 steinberg 304_ss poisson=0.285 tmelt=0.20509
matep 2 johnson copper poisson=0.346 tmelt=0.11898
matep 3 steinberg 304_ss poisson=0.285 tmelt=0.20509
vpsave
mix 3

```

```

endep
*
eos
  mat1 sesame st_steel
  mat2 sesame user eos=3336 feos='/ha/cta/unsupported/CTH/CTH_9903/data/seslan'
  mat3 mat1
  mat4 jwl octo178/22
endeos
*
heburn
  material 4 d 8.48e5 pre 1.0e12
  dp 0.0000 -26.0021 ti 0.0 radius 0.2
endheburn
*
tracer
  add 0.0 -10.0
endtracer
*
*eor*cthin
*
Bill Walters' Shape Charge: Single Liner Baseline
*
control
  tstop=60.e-6
  cpshift=900.
  rdumpf=3600
  ntbad 100000000
endcontrol
*
restart
  cycle=0
endr
*
cellthermo
  mmp1
endcell
*
convct
  convect=1
  interface=high
endc
*
discard
  material 4 density -0.01 pressure 5.0e6 ton 30.0e-6

```

```

endd
*
edit
  shortt
    time=0. dtf=10000.
  ends
  longt
    time=0. dtf=10000.
  endl
  plott
    time=0. dtf=1.0e-6
  endp
  plotdata
    volume
    pressure
    velocity
  endplotdata
  restt
    time=0 dtf=10.e-6
  endr
  histc
    cycle=0 dcfreq=1
    htracer1
  endh
endedit
*
mindt
  time=0. dtmin=1.0e-11
  time=20.0e-6 dtmin=1.0e-10
endm
*
fracts
  pressure
  pfrac1=-25.0e9
  pfrac2=-15.0e9
  pfrac3=-25.0e9
  pfrac4= -1.0e-9
  pfmix =-5.0E20
  pfvoid=-5.0E20
endf
*
boundary
  bhydro
  block=1

```

```
    bxbot 0
    bxtop 2
    bybot 2
    bytop 2
  endb
endh
endb
*
*eor*ptin
*
```

INTENTIONALLY LEFT BLANK.

Appendix C.
Input Deck for Shpdbl3 Double Confinement Shaped Charge

This appendix appears in its original form, without editorial change.

INTENTIONALLY LEFT BLANK.

```

*
* id=3 - Outer liner extended so it no longer is a truncated cone.
*   Detonation point changed so detonation wave hits inner liner
*   at same delay time as before.
*
*eor*cgenin
*
Bill Walters' Shape Charge: Double Confined Liner
*
control
  ep
  mmp
endcontrol
*
mesh
  block geometry 2dc type e
    x0=0.0
    x1 n=208 dxf=0.05 rat=1.
  endx
  y0=-31.0
  y1 n=1020 dyf=0.05 rat=1.
  endy
*   xact=0.0,1.0
*   yact=0.0,5.0
  endblock
endmesh
*
insertion of material
  block 1
*
* NOTE: From of steel cover sit at x-coordinate origin.
*
  package 'Steel Cover'
    material 1
    numsub 50
    insert uds
      point 4.7322 0.0000
      point 6.4000 0.0000
      point 6.4000 -2.0000
      point 4.7322 -2.0000
    endinsert
  endpackage
*
  package 'Main Cu liner'

```

```

material 2
numsub 50
insert uds
  point 0.0000 -14.3278
  point 4.7322 -2.0000
  point 5.0000 -2.0000
  point 0.0000 -15.0254
endinsert
endpackage
*
package 'Middle Cu liner'
material 3
numsub 50
insert uds
  point 0.0000 -22.5254
  point 5.1251 -2.0000
  point 5.5000 -2.0000
  point 0.0000 -23.5021
endinsert
endpackage
*
package 'Outer Steel liner'
material 4
numsub 50
insert uds
  point 0.0000 -27.1133
  point 5.6502 -2.0000
  point 6.4000 -2.0000
  point 0.0000 -30.4459
endinsert
endpackage
*
package 'Octol Charge'
material 5
numsub 50
insert uds
  point 0.0000 -15.0254
  point 5.0000 -2.0000
  point 5.6502 -2.0000
  point 0.0000 -27.1133
endinsert
endpackage
*
endblock

```

```

endinsertion
*
epdata
*
* NOTE: Poisson's Ratio was estimated from  $G=(3*(1-2*v))/(2*(1+v))*rho*C**2$ ;
*   where G, v, rho, and C are the shear modulus, Poisson's Ratio,
*   density, and bulk sound speed, respectively. All material parameters
*   except Poisson's Ratio came from Steinberg.
*
matep 1 steinberg 304_ss poisson=0.285 tmelt=0.20509
matep 2 johnson copper poisson=0.346 tmelt=0.11898
matep 3 johnson copper poisson=0.346 tmelt=0.11898
matep 4 steinberg 304_ss poisson=0.285 tmelt=0.20509
vpsave
mix 3
endep
*
eos
mat1 sesame st_steel
mat2 sesame user eos=3336 feos='/ha/cta/unsupported/CTH/CTH_9903/data/seslan'
mat3 mat2
mat4 mat1
mat5 jwl octol78/22
endeos
*
heburn
material 5 d 8.48e5 pre 1.0e12
  dp 0.0000 -27.1133 ti 0.0 radius 0.2
  dp 0.0000 -22.5254 ti 9.31e-6 radius 0.2
endheburn
*
tracer
  add 0.0 -10.0
endtracer
*
*eor*cthin
*
Bill Walters' Shape Charge: Double Confined Liner
*
control
  tstop=60.e-6
  cpshift=900.
  rdumpf=3600
  ntbad 100000000

```

```
endcontrol
*
restart
  cycle=0
endr
*
cellthermo
  mmp1
endcell
*
convct
  convect=1
  interface=high
endc
*
discard
  material 5 density -0.01 pressure 5.0e6 ton 30.0e-6
endd
*
edit
  shortt
    time=0. dtf=10000.
  ends
  longt
    time=0. dtf=10000.
  endl
  plott
    time=0. dtf=1.0e-6
  endp
  plotdata
    volume
    pressure
    velocity
  endplotdata
  restt
    time=0 dtf=10.e-6
  endr
  histc
    cycle=0 dcfreq=1
    htracer1
  endh
endedit
*
mindt
```

```
time=0. dtmin=1.0e-11
time=20.0e-6 dtmin=1.0e-10
endm
*
fracts
pressure
pfrac1=-25.0e9
pfrac2=-15.0e9
pfrac3=-15.0e9
pfrac4=-25.0e9
pfrac5= -1.0e-9
pfmix =-5.0E20
pvoid=-5.0E20
endf
*
boundary
bhydro
  block=1
  bxbot 0
  bxtop 2
  bybot 2
  bytop 2
  endb
endh
endb
*
*eor*ptin
*
```

INTENTIONALLY LEFT BLANK.

Appendix D.
Input Deck for Shpsgl4 Single Confinement Shaped Charge

This appendix appears in its original form, without editorial change.

INTENTIONALLY LEFT BLANK.

```

*
* id=4 - Outer liner extended so it no longer is a truncated cone.
*
*eor*cgenin
*
Bill Walters' Shape Charge: Single Liner Baseline
*
control
  ep
  mmp
endcontrol
*
mesh
  block geometry 2dc type e
    x0=0.0
    x1 n=208 dxf=0.05 rat=1.
  endx
  y0=-31.0
  y1 n=1020 dyf=0.05 rat=1.
  endy
* xact=0.0,1.0
* yact=0.0,5.0
  endblock
endmesh
*
insertion of material
  block 1
  *
  * NOTE: From of steel cover sit at x-coordinate origin.
  *
  package 'Steel Cover'
    material 1
    numsub 50
    insert uds
      point 4.7322 0.0000
      point 6.4000 0.0000
      point 6.4000 -2.0000
      point 4.7322 -2.0000
    endinsert
  endpackage
*
  package 'Main Cu liner'
    material 2
    numsub 50

```

```

insert uds
  point 0.0000 -14.3278
  point 4.7322 -2.0000
  point 5.0000 -2.0000
  point 0.0000 -15.0254
endinsert
endpackage
*
package 'Outer Steel liner'
  material 3
  numsub 50
  insert uds
    point 0.0000 -27.1133
    point 5.6502 -2.0000
    point 6.4000 -2.0000
    point 0.0000 -30.4459
  endinsert
endpackage
*
package 'Octol Charge'
  material 4
  numsub 50
  insert uds
    point 0.0000 -15.0254
    point 5.0000 -2.0000
    point 5.6502 -2.0000
    point 0.0000 -27.1133
  endinsert
endpackage
*
endblock
endinsertion
*
epdata
*
* NOTE: Poisson's Ratio was estimated from  $G=(3*(1-2*v))/(2*(1+v))*rho*C**2$ ;
*   where G, v, rho, and C and the shear modulus, Poisson's Ratio,
*   density, and bulk sound speed, respectively. All material parameters
*   except Poisson's Ratio came from Steinberg.
*
matep 1 steinberg 304_ss poisson=0.285 tmelt=0.20509
matep 2 johnson copper poisson=0.346 tmelt=0.11898
matep 3 steinberg 304_ss poisson=0.285 tmelt=0.20509
vpsave

```

```
mix 3
endep
*
eos
mat1 sesame st_steel
mat2 sesame user eos=3336 feos='/ha/cta/unsupported/CTH/CTH_9903/data/seslan'
mat3 mat1
mat4 jwl octol78/22
endeos
*
heburn
material 4 d 8.48e5 pre 1.0e12
dp 0.0000 -27.1133 ti 0.0 radius 0.2
endheburn
*
tracer
add 0.0 -10.0
endtracer
*
*eor*cthin
*
Bill Walters' Shape Charge: Single Liner Baseline
*
control
tstop=60.e-6
cpshift=900.
rdumpf=3600
ntbad 100000000
endcontrol
*
restart
cycle=0
endr
*
cellthermo
mmp1
endcell
*
convct
convect=1
interface=high
endc
*
discard
```

```

material 4 density -0.01 pressure 5.0e6 ton 30.0e-6
endd
*
edit
shortt
  time=0. dtf=10000.
ends
longt
  time=0. dtf=10000.
endl
plott
  time=0. dtf=1.0e-6
endp
plotdata
  volume
  pressure
  velocity
endplotdata
restt
  time=0 dtf=10.e-6
endr
histc
  cycle=0 dcfreq=1
  htracer1
endh
endedit
*
mindt
  time=0. dtmin=1.0e-11
  time=20.0e-6 dtmin=1.0e-10
endm
*
fracts
  pressure
  pfrac1=-25.0e9
  pfrac2=-15.0e9
  pfrac3=-25.0e9
  pfrac4= -1.0e-9
  pfmix =-5.0E20
  pfvoid=-5.0E20
endf
*
boundary
  bhydro

```

```
block=1
  bxbot 0
  bxtop 2
  bybot 2
  bytop 2
endb
endh
endb
*
*eor*ptin
*
```

INTENTIONALLY LEFT BLANK.

Appendix E.
Input Deck for Shpdb15 Double Confinement Shaped Charge

This appendix appears in its original form, without editorial change.

INTENTIONALLY LEFT BLANK.

```

*
* id=3 - Outer liner extended so it no longer is a truncated cone.
*   Detonation point changed so detonation wave hits inner liner
*   at same delay time as before.
* id=5 - Johnson-Cook model for Cu replaced by strain independent Steinberg-
*   Guinan-Lund model.
*
*eor*cgenin
*
Bill Walters' Shape Charge: Double Confined Liner
*
control
  ep
  mmp
endcontrol
*
mesh
  block geometry 2dc type e
    x0=0.0
    x1 n=208 dxf=0.05 rat=1.
  endx
  y0=-31.0
  y1 n=1020 dyf=0.05 rat=1.
  endy
*   xact=0.0,1.0
*   yact=0.0,5.0
  endblock
endmesh
*
insertion of material
  block 1
  *
  * NOTE: From of steel cover sit at x-coordinate origin.
  *
  package 'Steel Cover'
  material 1
  numsub 50
  insert uds
    point 4.7322 0.0000
    point 6.4000 0.0000
    point 6.4000 -2.0000
    point 4.7322 -2.0000
  endinsert
endpackage

```

```
*
package 'Main Cu liner'
material 2
numsub 50
insert uds
  point 0.0000 -14.3278
  point 4.7322 -2.0000
  point 5.0000 -2.0000
  point 0.0000 -15.0254
endinsert
endpackage
```

```
*
package 'Middle Cu liner'
material 3
numsub 50
insert uds
  point 0.0000 -22.5254
  point 5.1251 -2.0000
  point 5.5000 -2.0000
  point 0.0000 -23.5021
endinsert
endpackage
```

```
*
package 'Outer Steel liner'
material 4
numsub 50
insert uds
  point 0.0000 -27.1133
  point 5.6502 -2.0000
  point 6.4000 -2.0000
  point 0.0000 -30.4459
endinsert
endpackage
```

```
*
package 'Octol Charge'
material 5
numsub 50
insert uds
  point 0.0000 -15.0254
  point 5.0000 -2.0000
  point 5.6502 -2.0000
  point 0.0000 -27.1133
endinsert
endpackage
```

```

*
endblock
endinsertion
*
epdata
*
* NOTE: Poisson's Ratio was estimated from  $G=(3*(1-2*\nu))/(2*(1+\nu))*\rho*C**2$ ;
*   where G,  $\nu$ ,  $\rho$ , and C are the shear modulus, Poisson's Ratio,
*   density, and bulk sound speed, respectively. All material parameters
*   except Poisson's Ratio came from Steinberg.
*
matep 1 steinberg 304_ss poisson=0.285 tmelt=0.20509
matep 2 steinberg copper poisson=0.346 tmelt=0.11898
matep 3 steinberg copper poisson=0.346 tmelt=0.11898
matep 4 steinberg 304_ss poisson=0.285 tmelt=0.20509
vpsave
mix 3
endep
*
eos
mat1 sesame st_steel
mat2 sesame user eos=3336 feos='/ha/cta/unsupported/CTH/CTH_9903/data/seslan'
mat3 mat2
mat4 mat1
mat5 jwl octol78/22
endeos
*
heburn
material 5 d 8.48e5 pre 1.0e12
dp 0.0000 -27.1133 ti 0.0 radius 0.2
dp 0.0000 -22.5254 ti 9.31e-6 radius 0.2
endheburn
*
tracer
add 0.0 -10.0
endtracer
*
*eor*cthin
*
Bill Walters' Shape Charge: Double Confined Liner
*
control
tstop=60.e-6
cpshift=900.

```

```
rdumpf=3600
ntbad 100000000
endcontrol
*
restart
  cycle=0
endr
*
cellthermo
  mmp1
endcell
*
convct
  convect=1
  interface=high
endc
*
discard
  material 5 density -0.01 pressure 5.0e6 ton 30.0e-6
endd
*
edit
  shortt
    time=0. dtf=10000.
  ends
  longt
    time=0. dtf=10000.
  endl
  plott
    time=0. dtf=1.0e-6
  endp
  plotdata
    volume
    mass
    temperature
    pressure
    velocity
  endplotdata
  restt
    time=0 dtf=10.e-6
  endr
  histc
    cycle=0 dcfreq=1
    htracer1
```

```
endh
endedit
*
mindt
  time=0. dtmin=1.0e-11
  time=20.0e-6 dtmin=1.0e-10
endm
*
fracts
  pressure
  pfrac1=-25.0e9
  pfrac2=-15.0e9
  pfrac3=-15.0e9
  pfrac4=-25.0e9
  pfrac5= -1.0e-9
  pfmix =-5.0E20
  pvoid=-5.0E20
endf
*
boundary
  bhydro
    block=1
    bxbot 0
    bxtop 2
    bybot 2
    bytop 2
  endb
endh
endb
*
*eor*ptin
*
units cgsev
*
```

INTENTIONALLY LEFT BLANK.

Appendix F.
Input Deck for Bildbl1 Double Confinement Shaped Charge

This appendix appears in its original form, without editorial change.

INTENTIONALLY LEFT BLANK.

```

*
* Id=1 - Initial double liner configuration
*
*eor*cgenin
*
Bill Walters' Shape Charge: Double Confined Liner
*
control
  ep
  mmp
endcontrol
*
mesh
  block geometry 2dc type e
    x0=0.0
    x1 n=208 dxf=0.05 rat=1.
    endx
    y0=-31.0
    y1 n=1020 dyf=0.05 rat=1.
    endy
*   xact=0.0,1.0
*   yact=0.0,5.0
  endblock
endmesh
*
insertion of material
  block 1
*
* NOTE: From of steel cover sit at x-coordinate origin.
*
  package 'Steel Cover'
    material 1
    numsub 50
    insert uds
      point 4.7322 0.0000
      point 6.4000 0.0000
      point 6.4000 -2.0000
      point 4.7322 -2.0000
    endinsert
  endpackage
*
  package 'Main Cu liner'
    material 2

```

```

numsub 50
insert uds
  point 0.0000 -14.3278
  point 4.7322 -2.0000
  point 5.0000 -2.0000
  point 0.0000 -15.0254
endinsert
endpackage
*
package 'Middle Cu liner'
material 3
numsub 50
insert uds
  point 0.0000 -22.5254
  point 5.1392 -2.0000
  point 5.5000 -2.0000
  point 0.0000 -23.9665
endinsert
endpackage
*
package 'Outer Steel liner'
material 4
numsub 50
insert uds
  point 0.0000 -26.4665
  point 5.6814 -2.0000
  point 6.4000 -2.0000
  point 0.0000 -29.5612
endinsert
endpackage
*
package 'Octol Charge'
material 5
numsub 50
insert uds
  point 0.0000 -15.0254
  point 5.0000 -2.0000
  point 5.6814 -2.0000
  point 0.0000 -26.4665
endinsert
endpackage
*
endblock
endinsertion

```

```

*
epdata
*
* NOTE: Poisson's Ratio was estimated from  $G=(3*(1-2*\nu))/(2*(1+\nu))*\rho*C**2$ ;
*   where G,  $\nu$ ,  $\rho$ , and C and the shear modulus, Poisson's Ratio,
*   density, and bulk sound speed, respectively. All material parameters
*   except Poisson's Ratio came from Steinberg.
*
matep 1 steinberg 304_ss poisson=0.285 tmelt=0.20509
matep 2 steinberg copper poisson=0.346 tmelt=0.11898
matep 3 steinberg copper poisson=0.346 tmelt=0.11898
matep 4 steinberg 304_ss poisson=0.285 tmelt=0.20509
vpsave
mix 3
endep
*
eos
mat1 sesame st_steel
mat2 sesame user eos=3336 feos='/ha/cta/unsupported/CTH/CTH_9903/data/seslan'
mat3 mat2
mat4 mat1
mat5 jwl octol78/22
endeos
*
heburn
material 5 d 8.48e5 pre 1.0e12
  dp 0.0000 -26.4215 ti 0.0 radius 0.2
  dp 0.0000 -22.5004 ti 9.27e-6 radius 0.2
endheburn
*
tracer
add 0.0 -10.0
endtracer
*
*eor*cthin
*
Bill Walters' Shape Charge: Double Confined Liner
*
control
tstop=60.e-6
cpshift=900.
rdumpf=3600
ntbad 100000000
endcontrol

```

```

*
restart
  cycle=0
endr
*
cellthermo
  mmp1
endcell
*
convct
  convect=1
  interface=high
endc
*
discard
  material 5 density -0.01 pressure 5.0e6 ton 30.0e-6
endd
*
edit
  shortt
    time=0. dtf=10000.
  ends
  longt
    time=0. dtf=10000.
  endl
  plott
    time=0. dtf=1.0e-6
  endp
  plotdata
    volume
    mass
    temperature
    pressure
    velocity
  endplotdata
  restt
    time=0 dtf=10.e-6
  endr
  histc
    cycle=0 dcfreq=1
    htracer1
  endh
endedit
*
```

```
mindt
  time=0. dtmin=1.0e-11
  time=20.0e-6 dtmin=1.0e-10
endm
*
fracts
  pressure
  pfrac1=-25.0e9
  pfrac2=-15.0e9
  pfrac3=-15.0e9
  pfrac4=-25.0e9
  pfrac5= -1.0e-9
  pfmix =-5.0E20
  pfvoid=-5.0E20
endf
*
boundary
  bhydro
  block=1
  bxbot 0
  bxtop 2
  bybot 2
  bytop 2
  endb
  endh
endb
*
*eor*ptin
*
```

INTENTIONALLY LEFT BLANK.

Appendix G.
Input Deck for Billsgl1 Single Confinement Shaped Charge

This appendix appears in its original form, without editorial change.

INTENTIONALLY LEFT BLANK.

```

*
* id=1 - Starting baseline configuration
*
*eor*cgenin
*
ID=1: Bill Walters' Shape Charge: Single Liner
*
control
  ep
  mmp
endcontrol
*
mesh
  block geometry 2dc type e
    x0=0.0
    x1 n=208 dxf=0.05 rat=1.
  endx
  y0=-31.0
  y1 n=1020 dyf=0.05 rat=1.
  endy
* xact=0.0,1.0
* yact=0.0,5.0
  endblock
endmesh
*
insertion of material
  block 1
  *
  * NOTE: From of steel cover sit at x-coordinate origin.
  *
  package 'Steel Cover'
    material 1
    numsub 50
    insert uds
      point 4.7322 0.0000
      point 6.4000 0.0000
      point 6.4000 -2.0000
      point 4.7322 -2.0000
    endinsert
  endpackage
*
  package 'Main Cu liner'
    material 2
    numsub 50

```

```

insert uds
  point 0.0000 -14.3278
  point 4.7322 -2.0000
  point 5.0000 -2.0000
  point 0.0000 -15.0254
endinsert
endpackage
*
package 'Outer Steel liner'
  material 3
  numsub 50
  insert uds
    point 0.0000 -26.4665
    point 5.6814 -2.0000
    point 6.4000 -2.0000
    point 0.0000 -29.5612
  endinsert
endpackage
*
package 'Octol Charge'
  material 4
  numsub 50
  insert uds
    point 0.0000 -15.0254
    point 5.0000 -2.0000
    point 5.6814 -2.0000
    point 0.0000 -26.4665
  endinsert
endpackage
*
endblock
endinsertion
*
epdata
*
* NOTE: Poisson's Ratio was estimated from  $G=(3*(1-2*v))/(2*(1+v))*rho*C**2$ ;
*   where G, v, rho, and C and the shear modulus, Poisson's Ratio,
*   density, and bulk sound speed, respectively. All material parameters
*   except Poisson's Ratio came from Steinberg.
*
matep 1 steinberg 304_ss poisson=0.285  tmelt=0.20509
matep 2 steinberg copper poisson=0.346  tmelt=0.11898
matep 3 steinberg 304_ss poisson=0.285  tmelt=0.20509
vpsave

```

```

mix 3
endep
*
eos
  mat1 sesame st_steel
  mat2 sesame user eos=3336 feos='/ha/cta/unsupported/CTH/CTH_9903/data/seslan'
  mat3 mat1
  mat4 jwl octol78/22
endeos
*
heburn
  material 4 d 8.48e5 pre 1.0e12
  dp 0.0000 -26.4415 ti 0.0 radius 0.2
endheburn
*
tracer
  add 0.0 -10.0
endtracer
*
*eor*cthin
*
ID=1: Bill Walters' Shape Charge: Single Liner
*
control
  tstop=60.e-6
  cpshift=900.
  rdumpf=3600
  ntbad 100000000
endcontrol
*
restart
  cycle=0
endr
*
cellthermo
  mmp1
endcell
*
convct
  convect=1
  interface=high
endc
*
discard

```

```
material 4 density -0.01 pressure 5.0e6 ton 30.0e-6
endd
*
edit
shortt
  time=0. dtf=10000.
ends
longt
  time=0. dtf=10000.
endl
plott
  time=0. dtf=1.0e-6
endp
plotdata
  volume
  mass
  temperature
  pressure
  velocity
endplotdata
restt
  time=0 dtf=10.e-6
endr
hisc
  cycle=0 dcfreq=1
  htracer1
endh
endedit
*
mindt
  time=0. dtmin=1.0e-11
  time=20.0e-6 dtmin=1.0e-10
endm
*
fracts
  pressure
  pfrac1=-25.0e9
  pfrac2=-15.0e9
  pfrac3=-25.0e9
  pfrac4= -1.0e-9
  pfmix =-5.0E20
  pfvoid=-5.0E20
endf
*
```

```
boundary
bhydro
  block=1
  bxbot 0
  bxtop 2
  bybot 2
  bytop 2
endb
endh
endb
*
*eor*ptin
*
```

INTENTIONALLY LEFT BLANK.

Appendix H.
Input Deck for Bildbl2 Double Confinement Shaped Charge

This appendix appears in its original form, without editorial change.

INTENTIONALLY LEFT BLANK.

```

*
* Id=1 - Initial double liner configuration
* Id=2 - Geometry of the outer liners changed. They are now tapered and outer
*   radius decreased
*
*eor*cgenin
*
Id=2: Bill Walters' Shape Charge: Double Confined Liner
*
control
  ep
  mmp
endcontrol
*
mesh
  block geometry 2dc type e
    x0=0.0
    x1 n=208 dxf=0.05 rat=1.
  endx
  y0=-31.0
  y1 n=1020 dyf=0.05 rat=1.
  endy
*  xact=0.0,1.0
*  yact=0.0,5.0
  endblock
endmesh
*
insertion of material
  block 1
*
* NOTE: From of steel cover sit at x-coordinate origin.
*
  package 'Steel Cover'
    material 1
    numsub 50
    insert uds
      point 4.7322 0.0000
      point 5.7000 0.0000
      point 5.7000 -1.0000
      point 4.7322 -1.0000
    endinsert
  endpackage
*
  package 'Main Cu liner'

```

```

material 2
numsub 50
insert uds
  point 0.0000 -13.3278
  point 4.7322 -1.0000
  point 5.0000 -1.0000
  point 0.0000 -14.0254
endinsert
endpackage
*
package 'Middle Cu liner'
material 3
numsub 50
insert uds
  point 0.0000 -21.5254
  point 5.0696 -1.0000
  point 5.2500 -1.0000
  point 0.0000 -22.9665
endinsert
endpackage
*
package 'Outer Steel liner'
material 4
numsub 50
insert uds
  point 0.0000 -25.4665
  point 5.3407 -1.0000
  point 5.7000 -1.0000
  point 0.0000 -28.5612
endinsert
endpackage
*
package 'Octol Charge'
material 5
numsub 50
insert uds
  point 0.0000 -14.0254
  point 5.0000 -1.0000
  point 5.3407 -1.0000
  point 0.0000 -25.4665
endinsert
endpackage
*
endblock

```

```

endinsertion
*
epdata
*
* NOTE: Poisson's Ratio was estimated from  $G=(3*(1-2*v))/(2*(1+v))*rho*C**2$ ;
*   where G, v, rho, and C and the shear modulus, Poisson's Ratio,
*   density, and bulk sound speed, respectively. All material parameters
*   except Poisson's Ratio came from Steinberg.
*
matep 1 steinberg 304_ss poisson=0.285 tmelt=0.20509
matep 2 steinberg copper poisson=0.346 tmelt=0.11898
matep 3 steinberg copper poisson=0.346 tmelt=0.11898
matep 4 steinberg 304_ss poisson=0.285 tmelt=0.20509
vpsave
mix 3
endep
*
eos
mat1 sesame st_steel
mat2 sesame user eos=3336 feos='/ha/cta/unsupported/CTH/CTH_9903/data/seslan'
mat3 mat2
mat4 mat1
mat5 jwl octo178/22
endeos
*
heburn
material 5 d 8.48e5 pre 1.0e12
  dp 0.0000 -25.4215 ti 0.0 radius 0.2
  dp 0.0000 -21.5004 ti 9.27e-6 radius 0.2
endheburn
*
tracer
  add 0.0 -10.0
endtracer
*
*eor*cthin
*
Id=2: Bill Walters' Shape Charge: Double Confined Liner
*
control
  tstop=60.e-6
  cpshift=900.
  rdumpf=3600
  ntbad 100000000

```

```

endcontrol
*
restart
  cycle=0
endr
*
cellthermo
  mmp1
endcell
*
convct
  convect=1
  interface=high
endc
*
discard
  material 5 density -0.01 pressure 5.0e6 ton 30.0e-6
endd
*
edit
  shortt
    time=0. dtf=10000.
  ends
  longt
    time=0. dtf=10000.
  endl
  plott
    time=0. dtf=1.0e-6
  endp
  plotdata
    volume
    mass
    temperature
    pressure
    velocity
  endplotdata
  restt
    time=0 dtf=10.e-6
  endr
  histc
    cycle=0 dcfreq=1
    htracer1
  endh
endedit

```

```
*
mindt
  time=0. dtmin=1.0e-11
  time=20.0e-6 dtmin=1.0e-10
endm
*
fracts
  pressure
  pfrac1=-25.0e9
  pfrac2=-15.0e9
  pfrac3=-15.0e9
  pfrac4=-25.0e9
  pfrac5= -1.0e-9
  pfmix =-5.0E20
  pfvoid=-5.0E20
endf
*
boundary
  bhydro
    block=1
    bxbot 0
    bxtop 2
    bybot 2
    bytop 2
  endb
endh
endb
*
*eor*ptin
*
```

INTENTIONALLY LEFT BLANK.

Appendix I.
Input Deck for Billsgl2 Single Confinement Shaped Charge

This appendix appears in its original form, without editorial change.

INTENTIONALLY LEFT BLANK.

```

*
* id=1 - Starting baseline configuration
*
*eor*cgenin
*
ID=2: Bill Walters' Shape Charge: Single Liner
*
control
  ep
  mmp
endcontrol
*
mesh
  block geometry 2dc type e
  x0=0.0
  x1 n=208 dx=0.05 rat=1.
  endx
  y0=-31.0
  y1 n=1020 dy=0.05 rat=1.
  endy
* xact=0.0,1.0
* yact=0.0,5.0
  endblock
endmesh
*
insertion of material
  block 1
*
* NOTE: From of steel cover sit at x-coordinate origin.
*
  package 'Steel Cover'
  material 1
  numsub 50
  insert uds
  point 4.7322 0.0000
  point 5.7000 0.0000
  point 5.7000 -1.0000
  point 4.7322 -1.0000
  endinsert
endpackage
*
  package 'Main Cu liner'
  material 2

```

```

numsub 50
insert uds
  point 0.0000 -13.3278
  point 4.7322 -1.0000
  point 5.0000 -1.0000
  point 0.0000 -14.0254
endinsert
endpackage
*
package 'Outer Steel liner'
material 3
numsub 50
insert uds
  point 0.0000 -25.4665
  point 5.3407 -1.0000
  point 5.7000 -1.0000
  point 0.0000 -28.5612
endinsert
endpackage
*
package 'Octol Charge'
material 4
numsub 50
insert uds
  point 0.0000 -14.0254
  point 5.0000 -1.0000
  point 5.3407 -1.0000
  point 0.0000 -25.4665
endinsert
endpackage
*
endblock
endinsertion
*
epdata
*
* NOTE: Poisson's Ratio was estimated from  $G=(3*(1-2*v))/(2*(1+v))*rho*C**2$ ;
* where G, v, rho, and C and the shear modulus, Poisson's Ratio,
* density, and bulk sound speed, respectively. All material parameters
* except Poisson's Ratio came from Steinberg.
*
matep 1 steinberg 304_ss poisson=0.285 tmelt=0.20509
matep 2 steinberg copper poisson=0.346 tmelt=0.11898
matep 3 steinberg 304_ss poisson=0.285 tmelt=0.20509

```

```

vpsave
mix 3
endep
*
eos
mat1 sesame st_steel
mat2 sesame user eos=3336 feos='/ha/cta/unsupported/CTH/CTH_9903/data/seslan'
mat3 mat1
mat4 jwl octol78/22
endeos
*
heburn
material 4 d 8.48e5 pre 1.0e12
dp 0.0000 -25.4415 ti 0.0 radius 0.2
endheburn
*
tracer
add 0.0 -10.0
endtracer
*
*eor*cthin
*
ID=2: Bill Walters' Shape Charge: Single Liner
*
control
tstop=60.e-6
cpshift=900.
rdumpf=3600
ntbad 100000000
endcontrol
*
restart
cycle=0
endr
*
cellthermo
mmp1
endcell
*
convct
convect=1
interface=high
endc
*

```

```

discard
  material 4 density -0.01 pressure 5.0e6 ton 30.0e-6
endd
*
edit
  shortt
    time=0. dtf=10000.
  ends
  longt
    time=0. dtf=10000.
  endl
  plott
    time=0. dtf=1.0e-6
  endp
  plotdata
    volume
    mass
    temperature
    pressure
    velocity
  endplotdata
  restt
    time=0 dtf=10.e-6
  endr
  histc
    cycle=0 dcfreq=1
    htracer1
  endh
endedit
*
mindt
  time=0. dtmin=1.0e-11
  time=20.0e-6 dtmin=1.0e-10
endm
*
fracts
  pressure
  pfrac1=-25.0e9
  pfrac2=-15.0e9
  pfrac3=-25.0e9
  pfrac4= -1.0e-9
  pfmix =-5.0E20
  pfvoid=-5.0E20
endf

```

```
*
boundary
  bhydro
    block=1
    bxbot 0
    bxtop 2
    bybot 2
    bytop 2
  endb
endh
endb
*
*eor
*ptin
*
```

INTENTIONALLY LEFT BLANK.

Appendix J.
Input Deck for Bildbl3 Double Confinement Shaped Charge

This appendix appears in its original form, without editorial change.

INTENTIONALLY LEFT BLANK.

```

*
* Id=1 - Initial double liner configuration
* Id=2 - Geometry of the outer liners changed. They are now tapered and outer
*   radius decreased
* Id=3 - Returning to the original geometry the shape of the middle liner
*   only is changed.
*
*eor*cgenin
*
Id=3: Bill Walters' Shape Charge: Double Confined Liner
*
control
  ep
  mmp
endcontrol
*
mesh
  block geometry 2dc type e
    x0=0.0
    x1 n=208 dxf=0.05 rat=1.
  endx
  y0=-31.0
  y1 n=1020 dyf=0.05 rat=1.
  endy
*   xact=0.0,1.0
*   yact=0.0,5.0
  endblock
endmesh
*
insertion of material
  block 1
*
* NOTE: From of steel cover sit at x-coordinate origin.
*
  package 'Steel Cover'
    material 1
    numsub 50
    insert uds
      point 4.7322 0.0000
      point 6.4000 0.0000
      point 6.4000 -2.0000
      point 4.7322 -2.0000
    endinsert
  endpackage

```

```
*
package 'Main Cu liner'
material 2
numsub 50
insert uds
  point 0.0000 -14.3278
  point 4.7322 -2.0000
  point 5.0000 -2.0000
  point 0.0000 -15.0254
endinsert
endpackage
```

```
*
package 'Middle Cu liner'
material 3
numsub 50
insert uds
  point 0.0000 -20.0254
  point 5.1392 -2.0000
  point 5.5032 -2.0000
  point 0.0000 -21.3020
endinsert
endpackage
```

```
*
package 'Outer Steel liner'
material 4
numsub 50
insert uds
  point 0.0000 -26.4665
  point 5.6814 -2.0000
  point 6.4000 -2.0000
  point 0.0000 -29.5612
endinsert
endpackage
```

```
*
package 'Octol Charge'
material 5
numsub 50
insert uds
  point 0.0000 -15.0254
  point 5.0000 -2.0000
  point 5.6814 -2.0000
  point 0.0000 -26.4665
endinsert
endpackage
```

```

*
endblock
endinsertion
*
epdata
*
* NOTE: Poisson's Ratio was estimated from  $G=(3*(1-2*v))/(2*(1+v))*rho*C**2$ ;
* where G, v, rho, and C and the shear modulus, Poisson's Ratio,
* density, and bulk sound speed, respectively. All material parameters
* except Poisson's Ratio came from Steinberg.
*
matep 1 steinberg 304_ss poisson=0.285 tmelt=0.20509
matep 2 steinberg copper poisson=0.346 tmelt=0.11898
matep 3 steinberg copper poisson=0.346 tmelt=0.11898
matep 4 steinberg 304_ss poisson=0.285 tmelt=0.20509
vpsave
mix 3
endep
*
eos
mat1 sesame st_steel
mat2 sesame user eos=3336 feos='/ha/cta/unsupported/CTH/CTH_9903/data/seslan'
mat3 mat2
mat4 mat1
mat5 jwl octol78/22
endeos
*
heburn
material 5 d 8.48e5 pre 1.0e12
dp 0.0000 -26.4415 ti 0.0 radius 0.2
dp 0.0000 -20.0004 ti 8.19e-6 radius 0.2
endheburn
*
tracer
add 0.0 -10.0
endtracer
*
*eor*cthin
*
Id=3: Bill Walters' Shape Charge: Double Confined Liner
*
control
tstop=60.e-6
cpshift=900.

```

```

rdumpf=3600
ntbad 100000000
endcontrol
*
restart
  cycle=0
endr
*
cellthermo
  mmp1
endcell
*
convct
  convect=1
  interface=high
endc
*
discard
  material 5 density -0.01 pressure 5.0e6 ton 30.0e-6
endd
*
edit
  shortt
    time=0. dtf=10000.
  ends
  longt
    time=0. dtf=10000.
  endl
  plott
    time=0. dtf=1.0e-6
  endp
  plotdata
    volume
    mass
    temperature
    pressure
    velocity
  endplotdata
  restt
    time=0 dtf=10.e-6
  endr
  histc
    cycle=0 dcfreq=1
    htracer1

```

```
endh
endedit
*
mindt
  time=0. dtmin=1.0e-11
  time=20.0e-6 dtmin=1.0e-10
endm
*
fracts
  pressure
  pfrac1=-25.0e9
  pfrac2=-15.0e9
  pfrac3=-15.0e9
  pfrac4=-25.0e9
  pfrac5= -1.0e-9
  pfmix =-5.0E20
  pvoid=-5.0E20
endf
*
boundary
  bhydro
    block=1
    bxbot 0
    bxtop 2
    bybot 2
    bytop 2
  endb
endh
endb
*
*eor*pltin
*
```

INTENTIONALLY LEFT BLANK.

Appendix K.
Input Deck for Bildbl4 Double Confinement Shaped Charge

This appendix appears in its original form, without editorial change.

INTENTIONALLY LEFT BLANK.

```

*
* Id=1 - Initial double liner configuration
* Id=2 - Geometry of the outer liners changed. They are now tapered and outer
* radius decreased
* Id=3 - Returning to the original geometry the shape of the middle liner
* only is changed.
* Id=4 - Same as Id=3 except detonation times were changed to correspond with
* the delta time of detonation wave reaches middle liner.
*
*eor*cgenin
*
Id=4: Bill Walters' Shape Charge: Double Confined Liner
*
control
  ep
  mmp
endcontrol
*
mesh
  block geometry 2dc type e
    x0=0.0
    x1 n=208 dxf=0.05 rat=1.
    endx
    y0=-31.0
    y1 n=1020 dyf=0.05 rat=1.
    endy
  * xact=0.0,1.0
  * yact=0.0,5.0
  endblock
endmesh
*
insertion of material
  block 1
  *
  * NOTE: From of steel cover sit at x-coordinate origin.
  *
  package 'Steel Cover'
  material 1
  numsub 50
  insert uds
    point 4.7322 0.0000
    point 6.4000 0.0000
    point 6.4000 -2.0000
    point 4.7322 -2.0000

```

endinsert
endpackage

*

package 'Main Cu liner'
material 2
numsub 50
insert uds
point 0.0000 -14.3278
point 4.7322 -2.0000
point 5.0000 -2.0000
point 0.0000 -15.0254
endinsert
endpackage

*

package 'Middle Cu liner'
material 3
numsub 50
insert uds
point 0.0000 -20.0254
point 5.1392 -2.0000
point 5.5032 -2.0000
point 0.0000 -21.3020
endinsert
endpackage

*

package 'Outer Steel liner'
material 4
numsub 50
insert uds
point 0.0000 -26.4665
point 5.6814 -2.0000
point 6.4000 -2.0000
point 0.0000 -29.5612
endinsert
endpackage

*

package 'Octol Charge'
material 5
numsub 50
insert uds
point 0.0000 -15.0254
point 5.0000 -2.0000
point 5.6814 -2.0000
point 0.0000 -26.4665

```

    endinsert
  endpackage
*
  endblock
endinsertion
*
epdata
*
* NOTE: Poisson's Ratio was estimated from  $G=(3*(1-2*v))/(2*(1+v))*rho*C**2$ ;
*   where G, v, rho, and C are the shear modulus, Poisson's Ratio,
*   density, and bulk sound speed, respectively. All material parameters
*   except Poisson's Ratio came from Steinberg.
*
  matep 1 steinberg 304_ss poisson=0.285  tmelt=0.20509
  matep 2 steinberg copper poisson=0.346  tmelt=0.11898
  matep 3 steinberg copper poisson=0.346  tmelt=0.11898
  matep 4 steinberg 304_ss poisson=0.285  tmelt=0.20509
  vpsave
  mix 3
endep
*
eos
  mat1 sesame st_steel
  mat2 sesame user eos=3336 feos='/ha/cta/unsupported/CTH/CTH_9903/data/seslan'
  mat3 mat2
  mat4 mat1
  mat5 jwl octol78/22
endeos
*
heburn
  material 5 d 8.48e5 pre 1.0e12
  dp 0.0000 -26.4415 ti 0.0 radius 0.2
  dp 0.0000 -20.0004 ti 12.24e-6 radius 0.2
endheburn
*
tracer
  add 0.0 -10.0
endtracer
*
*eor*cthin
*
Id=4: Bill Walters' Shape Charge: Double Confined Liner
*
control

```

```

tstop=60.e-6
cpshift=900.
rdumpf=3600
ntbad 100000000
endcontrol
*
restart
  cycle=0
endr
*
cellthermo
  mmp1
endcell
*
convct
  convect=1
  interface=high
endc
*
discard
  material 5 density -0.01 pressure 5.0e6 ton 30.0e-6
endd
*
edit
  shortt
    time=0. dtf=10000.
  ends
  longt
    time=0. dtf=10000.
  endl
  plott
    time=0. dtf=1.0e-6
  endp
  plotdata
    volume
    mass
    temperature
    pressure
    velocity
  endplotdata
  restt
    time=0 dtf=10.e-6
  endr
  histc

```

```
    cycle=0 dcfreq=1
    htracer1
endh
endedit
*
mindt
time=0. dtmin=1.0e-11
time=20.0e-6 dtmin=1.0e-10
endm
*
fracts
pressure
pfrac1=-25.0e9
pfrac2=-15.0e9
pfrac3=-15.0e9
pfrac4=-25.0e9
pfrac5= -1.0e-9
pfmix =-5.0E20
pvoid=-5.0E20
endf
*
boundary
bhydro
block=1
  bxbot 0
  bxtop 2
  bybot 2
  bytop 2
endb
endh
endb
*
*eor*pltin
*
```

INTENTIONALLY LEFT BLANK.

Appendix L.
Input Deck for Newshp1 Double Confinement Shaped Charge

This appendix appears in its original form, without editorial change.

INTENTIONALLY LEFT BLANK.

```

*
* ID=1 - New Reduced diameter double liner configuration
*
*eor*cgenin
*
ID=1 Bill Walters' New Shape Charge: Double Confined Liner
*
control
  ep
  mmp
endcontrol
*
mesh
  block geometry 2dc type e
    x0=0.0
    x1 n=208 dxf=0.05 rat=1.
  endx
  y0=-31.0
  y1 n=1020 dyf=0.05 rat=1.
  endy
*  xact=0.0,1.0
*  yact=0.0,5.0
  endblock
endmesh
*
insertion of material
  block 1
*
* NOTE: From of steel cover sit at x-coordinate origin.
*
  package 'Main Cu liner'
    material 1
    numsub 50
    insert uds
      point 0.0000 -12.3278
      point 4.7322 0.0000
      point 4.7119 -0.7506
      point 0.0000 -13.0254
    endinsert
  endpackage
*
  package 'Middle Cu liner'
    material 2
    numsub 50

```

```

insert uds
  point 0.0000 -20.5254
  point 4.6845 -1.7645
  point 4.6416 -3.3560
  point 0.0000 -21.5021
endinsert
endpackage
*
package 'Outer Steel liner'
  material 3
  numsub 50
  insert uds
    point 0.0000 -25.1133
    point 4.6070 -4.6365
    point 4.7322 0.0000
    point 4.9322 0.0000
    point 4.7322 -7.4128
    point 0.0000 -28.4459
  endinsert
endpackage
*
package 'Octol Charge'
  material 4
  numsub 50
  insert uds
    point 0.0000 -13.0254
    point 4.7119 -0.7506
    point 4.6070 -4.6365
    point 0.0000 -25.1133
  endinsert
endpackage
*
endblock
endinsertion
*
epdata
*
* NOTE: Poisson's Ratio was estimated from  $G=(3*(1-2*v))/(2*(1+v))*rho*C**2$ ;
*   where G, v, rho, and C are the shear modulus, Poisson's Ratio,
*   density, and bulk sound speed, respectively. All material parameters
*   except Poisson's Ratio came from Steinberg.
*
matep 1 johnson copper poisson=0.346 tmelt=0.11898
matep 2 johnson copper poisson=0.346 tmelt=0.11898

```

```

matep 3 steinberg 304_ss poisson=0.285 tmelt=0.20509
vpsave
mix 3
endep
*
eos
mat1 mgrun copper
mat2 mat1
mat3 mgrun iron
mat4 jwl octol78/22
endeos
*
heburn
material 4 d 8.48e5 pre 1.0e12
dp 0.0000 -25.1133 ti 0.0 radius 0.2
dp 0.0000 -20.5254 ti 9.31e-6 radius 0.2
endheburn
*
tracer
add 0.0 -10.0
add 3.4598 -7.3298
add 4.3003 -7.6663
endtracer
*
*eor*cthin
*
ID=1 Bill Walters' New Shape Charge: Double Confined Liner
*
control
tstop=60.e-6
cpshift=900.
rdumpf=3600
ntbad 100000000
endcontrol
*
restart
cycle=0
endr
*
cellthermo
mmp1
endcell
*
convct

```

```

convect=1
interface=high
endc
*
discard
  material 4 density -0.01 pressure 5.0e6 ton 30.0e-6
enddd
*
edit
  shortt
    time=0. dtf=10000.
  ends
  longt
    time=0. dtf=10000.
  endl
  plott
    time=0. dtf=1.0e-6
  endp
  plotdata
    volume
    mass
    pressure
    velocity
  endplotdata
  restt
    time=0 dtf=10.e-6
  endr
  histc
    cycle=0 dcfreq=1
    htracer1
    htracer2
    htracer3
  endh
endedit
*
mindt
  time=0. dtmin=1.0e-11
  time=20.0e-6 dtmin=1.0e-10
endm
*
fracts
  pressure
  pfrac1=-15.0e9
  pfrac2=-15.0e9

```

```
pfrac3=-25.0e9
pfrac4= -1.0e-9
pfmix =-5.0E20
pvoid=-5.0E20
endf
*
boundary
bhydro
  block=1
  bxbot 0
  bxtop 2
  bybot 2
  bytop 2
  endb
endh
endb
*
*eor*ptin
*
```

INTENTIONALLY LEFT BLANK.

Appendix M.
Input Deck for Newshp2 Double Confinement Shaped Charge

This appendix appears in its original form, without editorial change.

INTENTIONALLY LEFT BLANK.

```

*
* Id=1 - Initial double liner configuration
*
*eor*cgenin
*
ID=1: Bill Walters' New Shape Charge 2: Double Confined Liner
*
control
  ep
  mmp
endcontrol
*
mesh
  block geometry 2dc type e
    x0=0.0
    x1 n=208 dxf=0.05 rat=1.
    endx
    y0=-31.0
    y1 n=1020 dyf=0.05 rat=1.
    endy
*   xact=0.0,1.0
*   yact=0.0,5.0
  endblock
endmesh
*
insertion of material
  block 1
  *
  * NOTE: From of steel cover sit at x-coordinate origin.
  *
  package 'Main Cu liner'
    material 1
    numsub 50
    insert uds
      point 0.0000 -12.3278
      point 4.7322 0.0000
      point 4.7112 -0.7524
      point 0.0000 -13.0254
    endinsert
  endpackage
*
  package 'Middle Cu liner'
    material 2
    numsub 50

```

```

insert uds
  point 0.0000 -20.5254
  point 4.6812 -1.8292
  point 4.6360 -3.4506
  point 0.0000 -21.9665
endinsert
endpackage
*
package 'Outer Steel liner'
material 3
numsub 50
insert uds
  point 0.0000 -24.4665
  point 4.6028 -4.6448
  point 4.7322 0.0000
  point 4.9322 0.0000
  point 4.7322 -7.1822
  point 0.0000 -27.5612
endinsert
endpackage
*
package 'Octol Charge'
material 4
numsub 50
insert uds
  point 0.0000 -13.0254
  point 4.7112 -0.7524
  point 4.6028 -4.6448
  point 0.0000 -24.4665
endinsert
endpackage
*
endblock
endinsertion
*
epdata
*
* NOTE: Poisson's Ratio was estimated from  $G=(3*(1-2*v))/(2*(1+v))*rho*C**2$ ;
* where G, v, rho, and C and the shear modulus, Poisson's Ratio,
* density, and bulk sound speed, respectively. All material parameters
* except Poisson's Ratio came from Steinberg.
*
matep 1 johnson copper poisson=0.346 tmelt=0.11898
matep 2 johnson copper poisson=0.346 tmelt=0.11898

```

```

matep 3 steinberg 304_ss poisson=0.285 tmelt=0.20509
vpsave
mix 3
endep
*
eos
mat1 mgrun copper
mat2 mat1
mat3 mgrun iron
mat4 jwl octol78/22
endeos
*
heburn
material 4 d 8.48e5 pre 1.0e12
dp 0.0000 -24.4215 ti 0.0 radius 0.2
dp 0.0000 -20.5004 ti 9.27e-6 radius 0.2
endheburn
*
tracer
add 0.0 -10.0
add 3.6283 -6.7551
add 4.3893 -7.1115
endtracer
*
*eor*cthin
*
ID=1: Bill Walters' New Shape Charge 2: Double Confined Liner
*
control
tstop=60.e-6
cpshift=900.
rdumpf=3600
ntbad 100000000
endcontrol
*
restart
cycle=0
endr
*
cellthermo
mmp1
endcell
*
convct

```

```

convect=1
interface=high
endc
*
discard
material 4 density -0.01 pressure 5.0e6 ton 30.0e-6
endd
*
edit
shortt
time=0. dtf=10000.
ends
longt
time=0. dtf=10000.
endl
plott
time=0. dtf=1.0e-6
endp
plotdata
volume
mass
temperature
pressure
velocity
endplotdata
restt
time=0 dtf=10.e-6
endr
histc
cycle=0 dcfreq=1
htracer1
htracer2
htracer3
endh
endedit
*
mindt
time=0. dtmin=1.0e-11
time=20.0e-6 dtmin=1.0e-10
endm
*
fracts
pressure
pfrac1=-15.0e9

```

```
pfrac2=-15.0e9
pfrac3=-25.0e9
pfrac4= -1.0e-9
pfmix =-5.0E20
pfvoid=-5.0E20
endf
*
boundary
bhydro
  block=1
  bxbot 0
  bxtop 2
  bybot 2
  bytop 2
  endb
endh
endb
*
*eor*ptin
*
```

INTENTIONALLY LEFT BLANK.

Appendix N.
Input Deck for Newbsl2 Double Confinement Shaped Charge

This appendix appears in its original form, without editorial change.

INTENTIONALLY LEFT BLANK.

```

*
* Id=1 - Initial double liner configuration
*
*eor*cgenin
*
ID=1: Bill Walters' New Shape Charge 2: Single Liner Baseline
*
control
  ep
  mmp
endcontrol
*
mesh
  block geometry 2dc type e
    x0=0.0
    x1 n=208 dxf=0.05 rat=1.
    endx
    y0=-31.0
    y1 n=1020 dyf=0.05 rat=1.
    endy
*   xact=0.0,1.0
*   yact=0.0,5.0
  endblock
endmesh
*
insertion of material
  block 1
*
* NOTE: From of steel cover sit at x-coordinate origin.
*
  package 'Main Cu liner'
    material 1
    numsub 50
    insert uds
      point 0.0000 -12.3278
      point 4.7322 0.0000
      point 4.7112 -0.7524
      point 0.0000 -13.0254
    endinsert
  endpackage
*
  package 'Outer Steel liner'
    material 2
    numsub 50

```

```

insert uds
  point 0.0000 -24.4665
  point 4.6028 -4.6448
  point 4.7322 0.0000
  point 4.9322 0.0000
  point 4.7322 -7.1822
  point 0.0000 -27.5612
endinsert
endpackage
*
package 'Octol Charge'
  material 3
  numsub 50
  insert uds
    point 0.0000 -13.0254
    point 4.7112 -0.7524
    point 4.6028 -4.6448
    point 0.0000 -24.4665
  endinsert
endpackage
*
endblock
endinsertion
*
epdata
*
* NOTE: Poisson's Ratio was estimated from  $G=(3*(1-2*\nu))/(2*(1+\nu))*\rho*C**2$ ;
*   where G,  $\nu$ ,  $\rho$ , and C and the shear modulus, Poisson's Ratio,
*   density, and bulk sound speed, respectively. All material parameters
*   except Poisson's Ratio came from Steinberg.
*
  matep 1 johnson copper poisson=0.346  tmelt=0.11898
  matep 2 steinberg 304_ss poisson=0.285  tmelt=0.20509
  vpsave
  mix 3
endep
*
eos
  mat1 mgrun copper
  mat2 mgrun iron
  mat3 jwl octol78/22
endeos
*
heburn

```

```

material 3 d 8.48e5 pre 1.0e12
  dp 0.0000 -24.4215 ti 0.0 radius 0.2
endheburn
*
tracer
  add 0.0 -10.0
  add 4.3893 -7.1115
endtracer
*
*eor*cthin
*
ID=1: Bill Walters' New Shape Charge 2: Single Liner Baseline
*
control
  tstop=60.e-6
  cpshift=900.
  rdumpf=3600
  ntbad 100000000
endcontrol
*
restart
  cycle=0
endr
*
cellthermo
  mmp1
endcell
*
convct
  convect=1
  interface=high
endc
*
discard
  material 3 density -0.01 pressure 5.0e6 ton 30.0e-6
endd
*
edit
  shortt
    time=0. dtf=10000.
  ends
  longt
    time=0. dtf=10000.
  endl

```

```

plott
  time=0. dtf=1.0e-6
endp
plotdata
  volume
  mass
  temperature
  pressure
  velocity
endplotdata
restt
  time=0 dtf=10.e-6
endr
histc
  cycle=0 dcfreq=1
  htracer1
  htracer2
endh
endedit
*
mindt
  time=0. dtmin=1.0e-11
  time=20.0e-6 dtmin=1.0e-10
endm
*
fracts
  pressure
  pfrac1=-15.0e9
  pfrac2=-25.0e9
  pfrac3= -1.0e-9
  pfmix =-5.0E20
  pfvoid=-5.0E20
endf
*
boundary
  bhydro
  block=1
  bxbot 0
  bxtop 2
  bybot 2
  bytop 2
  endb
endh
endb

```

*
*eor*ptin
*

INTENTIONALLY LEFT BLANK.

Appendix O.
Input Deck for Waveshp2 Double Confinement Shaped Charge

This appendix appears in its original form, without editorial change.

INTENTIONALLY LEFT BLANK.

```

*
* Id=1 - Initial double liner configuration
*
*eor*cgenin
*
ID=1: Bill Walters' New Shape Charge 2 w/Shaper: Double Confined Liner
*
control
  ep
  mmp
endcontrol
*
mesh
  block geometry 2dc type e
    x0=0.0
    x1 n=208 dxf=0.05 rat=1.
  endx
  y0=-31.0
  y1 n=1020 dyf=0.05 rat=1.
  endy
* xact=0.0,1.0
* yact=0.0,5.0
endblock
endmesh
*
insertion of material
  block 1
  *
* NOTE: From of steel cover sit at x-coordinate origin.
*
  package 'Main Cu liner'
    material 1
    numsub 50
    insert uds
      point 0.0000 -12.3278
      point 4.7322 0.0000
      point 4.7112 -0.7524
      point 0.0000 -13.0254
    endinsert
  endpackage
*
  package 'Middle Cu liner'
    material 2
    numsub 50

```

```
insert uds
  point 0.2000 -19.9867
  point 4.6812 -1.8292
  point 4.6360 -3.4506
  point 0.2000 -21.1677
endinsert
endpackage
```

*

```
package 'Steel Wave Shaper'
  material 3
  numsub 50
  insert uds
    point 0.0000 -23.2478
    point 0.6811 -20.3149
    point 1.1620 -19.4622
    point 0.0000 -24.4665
  endinsert
endpackage
```

*

```
package 'Outer Steel liner'
  material 3
  numsub 50
  insert uds
    point 0.3223 -24.6248
    point 1.5030 -19.5414
    point 1.3189 -18.7866
    point 4.6028 -4.6448
    point 4.7322 0.0000
    point 4.9322 0.0000
    point 4.7322 -7.1822
    point 0.6819 -24.6248
  endinsert
endpackage
```

*

```
package 'Octol Charge'
  material 4
  numsub 50
  insert uds
    point 0.0000 -13.0254
    point 4.7112 -0.7524
    point 4.6028 -4.6448
    point 1.3189 -18.7866
    point 1.5030 -19.5414
    point 0.3223 -24.6248
```

```

    point 0.0000 -24.6248
endinsert
endpackage
*
endblock
endinsertion
*
epdata
*
* NOTE: Poisson's Ratio was estimated from  $G=(3*(1-2*\nu))/(2*(1+\nu))*\rho*C**2$ ;
* where G,  $\nu$ ,  $\rho$ , and C and the shear modulus, Poisson's Ratio,
* density, and bulk sound speed, respectively. All material parameters
* except Poisson's Ratio came from Steinberg.
*
matep 1 johnson copper poisson=0.346 tmelt=0.11898
matep 2 johnson copper poisson=0.346 tmelt=0.11898
matep 3 steinberg 304_ss poisson=0.285 tmelt=0.20509
vpsave
mix 3
endep
*
eos
mat1 mgrun copper
mat2 mat1
mat3 mgrun iron
mat4 jwl octol78/22
endeos
*
heburn
material 4 d 8.48e5 pre 1.0e12
dp 0.0000 -24.6248 ti 0.0 radius 0.2
endheburn
*
tracer
add 0.0 -10.0
add 3.6283 -6.7551
add 4.3893 -7.1115
endtracer
*
*eor*cthin
*
ID=1: Bill Walters' New Shape Charge 2 w/Shaper: Double Confined Liner
*
control

```

```

tstop=60.e-6
cpshift=900.
rdumpf=3600
ntbad 100000000
endcontrol
*
restart
  cycle=0
endr
*
cellthermo
  mmp1
endcell
*
convct
  convect=1
  interface=high
endc
*
discard
  material 4 density -0.01 pressure 5.0e6 ton 30.0e-6
endd
*
edit
  shortt
    time=0. dtf=10000.
  ends
  longt
    time=0. dtf=10000.
  endl
  plott
    time=0. dtf=1.0e-6
  endp
  plotdata
    volume
    mass
    temperature
    pressure
    velocity
  endplotdata
  restt
    time=0 dtf=10.e-6
  endr
  histc

```

```
cycle=0 dcfreq=1
  htracer1
  htracer2
  htracer3
endh
endedit
*
mindt
  time=0. dtmin=1.0e-11
  time=20.0e-6 dtmin=1.0e-10
endm
*
fracts
  pressure
  pfrac1=-15.0e9
  pfrac2=-15.0e9
  pfrac3=-25.0e9
  pfrac4= -1.0e-9
  pfmix =-5.0E20
  pvoid=-5.0E20
endf
*
boundary
  bhydro
    block=1
    bxbot 0
    bxtop 2
    bybot 2
    bytop 2
  endb
endh
endb
*
*eor*ptin
*
```

INTENTIONALLY LEFT BLANK.

REPORT DOCUMENTATION PAGE

Form Approved
OMB No. 0704-0188

Public reporting burden for this collection of information is estimated to average 1 hour per response, including the time for reviewing instructions, searching existing data sources, gathering and maintaining the data needed, and completing and reviewing the collection of information. Send comments regarding this burden estimate or any other aspect of this collection of information, including suggestions for reducing this burden, to Washington Headquarters Services, Directorate for Information Operations and Reports, 1215 Jefferson Davis Highway, Suite 1204, Arlington, VA 22202-4302, and to the Office of Management and Budget, Paperwork Reduction Project(0704-0188), Washington, DC 20503.

1. AGENCY USE ONLY (Leave blank)		2. REPORT DATE August 2002	3. REPORT TYPE AND DATES COVERED Final, June 1999–May 2002	
4. TITLE AND SUBTITLE A Shaped Charge With Dual Confinement			5. FUNDING NUMBERS 1L162618AH80	
6. AUTHOR(S) Daniel R. Scheffler and William P. Walters				
7. PERFORMING ORGANIZATION NAME(S) AND ADDRESS(ES) U.S. Army Research Laboratory ATTN: AMSRL-WM-TC Aberdeen Proving Ground, MD 21001-5066			8. PERFORMING ORGANIZATION REPORT NUMBER ARL-TR-2791	
9. SPONSORING/MONITORING AGENCY NAMES(S) AND ADDRESS(ES)			10. SPONSORING/MONITORING AGENCY REPORT NUMBER	
11. SUPPLEMENTARY NOTES				
12a. DISTRIBUTION/AVAILABILITY STATEMENT Approved for public release; distribution is unlimited.			12b. DISTRIBUTION CODE	
13. ABSTRACT(Maximum 200 words) A computational study was performed on a shaped charge device with a double confinement. This concept was previously introduced by Walters and Segletes (Walters, W.P., and S. B. Segletes. "Shaped Charge Devices With Multiple Confinements." U.S. Patent 5,847,312, 8 December 1998). The design involved using a dual (or multiple) confinement body on a shaped charge. The goals were to at least maintain the performance of the shaped charge jet and to allow dual (or multiple) waves of fragments from the explosive confinement casings. The computational results from the CTH code indicate that these objectives were accomplished.				
14. SUBJECT TERMS shaped charge, jet formation, hydrocode, computer simulation, confinement, jet collapse, warhead			15. NUMBER OF PAGES 128	
			16. PRICE CODE	
17. SECURITY CLASSIFICATION OF REPORT UNCLASSIFIED	18. SECURITY CLASSIFICATION OF THIS PAGE UNCLASSIFIED	19. SECURITY CLASSIFICATION OF ABSTRACT UNCLASSIFIED	20. LIMITATION OF ABSTRACT UL	

INTENTIONALLY LEFT BLANK.