

# REPORT DOCUMENTATION PAGE

Form Approved  
OMB No. 0704-0188

Public reporting burden for this collection of information is estimated to average 1 hour per response, including the time for reviewing instructions, searching existing data sources, gathering and maintaining the data needed, and completing and reviewing this collection of information. Send comments regarding this burden estimate or any other aspect of this collection of information, including suggestions for reducing this burden to Department of Defense, Washington Headquarters Services, Directorate for Information Operations and Reports (0704-0188), 1215 Jefferson Davis Highway, Suite 1204, Arlington, VA 22202-4302. Respondents should be aware that notwithstanding any other provision of law, no person shall be subject to any penalty for failing to comply with a collection of information if it does not display a currently valid OMB control number. PLEASE DO NOT RETURN YOUR FORM TO THE ABOVE ADDRESS.

1. REPORT DATE (DD-MM-YYYY)		2. REPORT TYPE Technical Papers		3. DATES COVERED (From - To)	
4. TITLE AND SUBTITLE				5a. CONTRACT NUMBER	
				5b. GRANT NUMBER	
				5c. PROGRAM ELEMENT NUMBER	
6. AUTHOR(S)				5d. PROJECT NUMBER	
				5e. TASK NUMBER	
				5f. WORK UNIT NUMBER	
7. PERFORMING ORGANIZATION NAME(S) AND ADDRESS(ES) Air Force Research Laboratory (AFMC) AFRL/PRS 5 Pollux Drive Edwards AFB CA 93524-7048				8. PERFORMING ORGANIZATION REPORT	
9. SPONSORING / MONITORING AGENCY NAME(S) AND ADDRESS(ES) Air Force Research Laboratory (AFMC) AFRL/PRS 5 Pollux Drive Edwards AFB CA 93524-7048				10. SPONSOR/MONITOR'S ACRONYM(S)	
				11. SPONSOR/MONITOR'S NUMBER(S)	
12. DISTRIBUTION / AVAILABILITY STATEMENT  Approved for public release; distribution unlimited.					
13. SUPPLEMENTARY NOTES					
14. ABSTRACT  <div style="text-align: right; font-size: 2em; font-weight: bold;">20020828 128</div>					
15. SUBJECT TERMS					
16. SECURITY CLASSIFICATION OF:			17. LIMITATION OF ABSTRACT	18. NUMBER OF PAGES	19a. NAME OF RESPONSIBLE PERSON
a. REPORT	b. ABSTRACT	c. THIS PAGE			Leilani Richardson
Unclassified	Unclassified	Unclassified	A		19b. TELEPHONE NUMBER (include area code) (661) 275-5015

41 items enclosed

10/100GV/SW TP-FY99-0142

✓ Supplemental  
✓ DTS

MEMORANDUM FOR PRR (Contractor Publication)

FROM: PROI (TI) (STINFO)

8 June 1999

SUBJECT: Authorization for Release of Technical Information, Control Number: AFRL-PR-ED-TP-FY99-0142  
Wherley, Ulmer and Clafin (Boeing), "Injector and Combustion Chamber Advances Demonstrated on the Thrust  
Cell Technologies Program"

AIAA paper

(Statement A)

INJECTOR AND COMBUSTION CHAMBER ADVANCES DEMONSTRATED  
on the  
THRUST CELL TECHNOLOGIES PROGRAM

Brian Wherley, Don Ulmer and Scott Claflin  
Rocketdyne Division of Boeing  
Canoga Park, CA

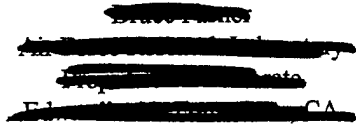

Abstract

This report covers achievements on the Thrust Cell Technologies Program (TCTP) from 1 September 1992 to 3 December 1998. The Thrust Cell Technologies Program was initiated by the Air Force Research Lab (AFRL) to 1) develop the materials and fabrication technologies needed to produce reliable, high-performance liquid oxygen/liquid hydrogen (LOX/LH<sub>2</sub>) thrust cells for advanced upper stage engines and multi-cell booster applications and 2) quantify the performance of modular thrust cells through computational fluid dynamics (CFD) analysis and cold-flow testing. The developed technologies were to be suitable and applicable to a variety of contemporaneous engine applications, specifically the Integrated Modular Engine (IME) upper stage, as well as the Advanced Upper Stage (AUS), Single-Stage-to-Orbit (SSTO), and National Aerospace Plane (NASP) vehicles and missions.

Consistent with IHPRPT (Integrated High-Payoff Rocket Propulsion Technology), the fundamental approach of TCTP was to develop advanced materials and fabrication techniques that reduce fabrication time, cost and part count while maintaining performance. All components and assemblies were modeled using either CATIA or ProEngineer three dimensional modeling design software to facilitate development of a range of Rapid Prototyping techniques using the Selective Laser Sintering (SLS) process. The SLS process fuses powdered polymer material with a laser, layer by layer, to build a three dimensional part. An extensive quantity of SLS work was performed in support of TCTP by Rocketdyne's Rapid Prototyping Lab that yielded completely new and revolutionary processes. These processes reduced development and fabrication time substantially. The development of rapid prototyping methods proceeded hand-in-hand with the development of an extensive database of casting and powder metal (P/M) technology. One hot-fire quality injector and mating

combustion chamber<sup>?</sup> were completed on this program.

Phase 1 - Definition of Design Requirements

The program was broken down into five technical and one management phase. Phase 1 activities included program plan preparation, definition of initial applications, and engine analyses to establish the baseline thrust cell design requirements. The Integrated Modular Engine (IME) concept was selected during the Phase 1 planning effort as the baseline from which design requirements for the thrust cell were generated. Phase 1 was completed in December 1992.

Phase 2 - First Level Technology Thrust Cell

The Phase 2 effort was intended to integrate rapid prototyping techniques (Selective Laser Sintered CAD-produced patterns) with conventional investment casting to produce near-net shape thrust cell liners. The baseline design fabrication process utilized LIDB (Liquid Interface Diffusion Bonding) of the manifolds to the liner and electrodeposited NiCo to fabricate the liner coolant channel close-out and structural jacket. One manufacturing technology demonstration (MTD) unit and one hot-fire quality first level technology thrust cell were planned under this phase, but only the MTD was completed. The First Level Technology thrust cell was eliminated in favor of the Advanced Level Technology thrust cell planned for Phase 4. The Advanced Level Technology thrust cell incorporated material property data and fabrication process knowledge generated during the Phase 2 MTD fabrication.

Manufacturing Technology Demonstration Unit

CAD data bases developed in Phase 2 were used to produce polymer patterns for generating casting molds and developing plating techniques. The polymer patterns were produced using the SLS process. Eighteen liner castings were produced. Each casting iteration served to refine the casting design, procedures, and gating

techniques for a metallurgically sound casting. MTD's were designed to obtain witness coupons from which thermal and mechanical property specimens were extracted. The tensile properties (room and elevated temperature) and thermal conductivity of as-cast NARloy-Z were determined. Microstructural analysis was used to assess the metallurgical soundness of the castings. Electrodeposited (ED) NiCo was used to close the inner channels and to form the structural jacket. ED NiCo is readily electroformed and has strength equivalent to Inconel 718 at room temperature and below. The ED Ni/Co process was tailored to the thrust cell configuration first using plastic liner models generated by the SLS process, then using the cast MTD's (see Figure 2). Process parameters, including the necessary cooling (shields) to obtain uniform deposition thickness were established. The SLS models and shields increased the accuracy and uniformity of the deposition and decreased the cost of shield fabrication. Fabrication and evaluation of the Phase 3 first level technology MTD combustion chamber unit was completed in September 1994.

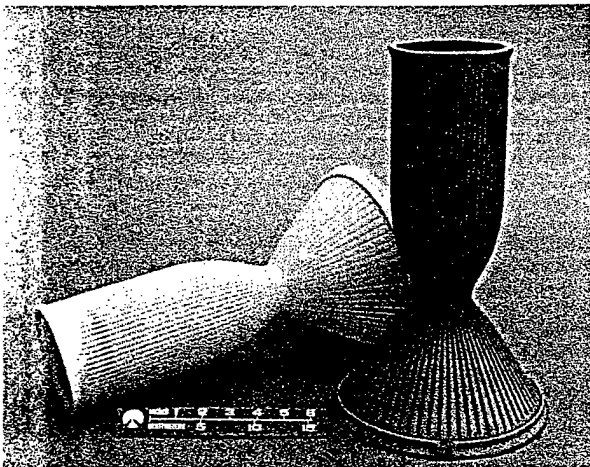

Figure 1: Polycarbonate SLS Liner Casting Pattern and Cast NARloy-Z Copper Alloy Liner

Phase 3 - Thrust Cell Shape Definition, Analysis, and Cold-Flow Testings

The Phase 3 effort defined and analyzed candidate thrust cell shapes, which were subsequently evaluated in cold-flow testing. The onset of the X-33 program heightened interest in complex shape nozzles. Characterization of the flow fields internally, externally between cells in multiple cell arrays and the interaction of the nozzle flow with a ramp and slip stream were studied. Preliminary shapes were defined and refined based on materials, structural, and thermal considerations. Aerodynamic analysis was performed as well and in-

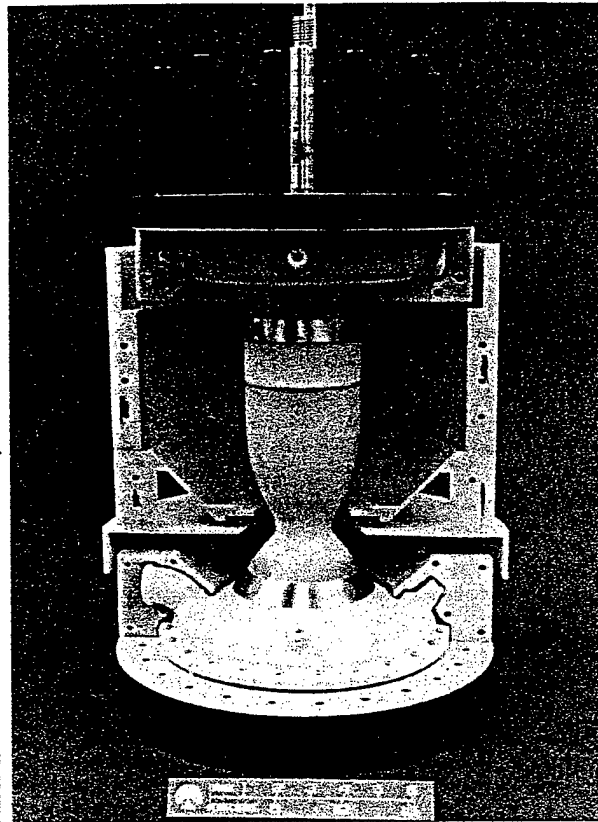

Figure 2: Polycarbonate Plating Development Model and Shielding Shown Ready for Electrodeposition of High Strength Nickel/Cobalt Alloy Produced by the Selective Laser Sintering Process (SLS).

cluded method of characteristics (MOC) and computational fluid dynamics (CFD) analysis. Selected shapes were fabricated and evaluated in individual and module (multi-cell) thrust cell cold-flow testing. The results of the cold-flow testing were used to refine and anchor CFD techniques and to optimize the thrust cell shape. The final output of this task included CFD analysis results, performance predictions, flow field characteristics, pressure profiles, and cold-flow test results for individual thrust cells as well as modules. The cold flow data included performance, pressure profiles and velocity profiles. Cold-flow testing was partially completed on a five-cell, linear aerospike module and the test results were compared with pre-test CFD analyses.

Cold-Flow Hardware Design and Fabrication

Based upon the results of the CFD analyses, three thrust cell shapes were designed using CAD. These thrust cells, with detailed internal contour only, were fabricated using SLS to form plastic models for cold-flow testing. One thrust cell configuration was selected for module testing and a five-thrust-cell module was de-

↑  
PHASE 3?  
COL 1

WHERE IS THE  
REFERENCE TO  
FIGURE 1?

signed and fabricated for cold-flow testing.

### Cold-Flow Testing

The cold-flow laboratory testing characterized the individual performance losses of thrust cell shapes and interaction losses for a five-thrust cell module in a cold-flow environment. The thrust cells were fabricated using the SLS process from a high-strength nylon/glass powder and subsequently cold-flow tested (with gaseous nitrogen) in the Rocketdyne Nozzle Test Facility (RNTF). The cold-flow model is illustrated in Figure 3. The plenum generated the slip stream flow. The installed multicell nozzle array, ramp and base plug were located as shown and heavily instrumented. The cold-flow effort consisted of two series of tests: a single thrust cell test series to characterize the performance losses of three distinct thrust cell shapes, and a five-thrust-cell module test series to characterize multiple thrust cell interaction losses and slipstream losses. Test data was obtained in the form of static pressure profiles, axial thrust measurements, Schlieren motion pictures, and velocity profile measurements using laser velocimetry techniques. Cold-flow testing of the five-cell, 2-D planar thrust cell/linear aerospike model was performed in late February 1996.

### Test Results

#### Wall Pressure

Wall pressure data was collected for simulated sea level and altitude tests (33% of design pressure ratio corresponding to ~48,000 ft altitude) for several locations along the test article. Locations included the centerline row, the quarter thrust cell row, and the row in line with the thrust cell gap. The peak pressures occurred near the gap where adjacent thrust cell flows were merging. Results of the cold-flow plug pressures measured along the centerline (row F) were compared with the 2-D method of characteristics (MOC) solution and the 3-D CFD solution. The MOC results under-predicted the initial pressures, over-predicted the central pressures, and matched fairly well at the exit. This was most likely due to using a start-line with the 1-D conditions at the exit of the thrust cell in the MOC calculation. The thrust cell exit flow field was highly three-dimensional in character, and to better predict the plug flow field, the 3-D effects would have to be included. CFD did a better job of matching the 3-D effects on the plug surface than did the MOC analysis, especially along row D, though the solution over-predicted the pressure in several areas. The CFD solu-

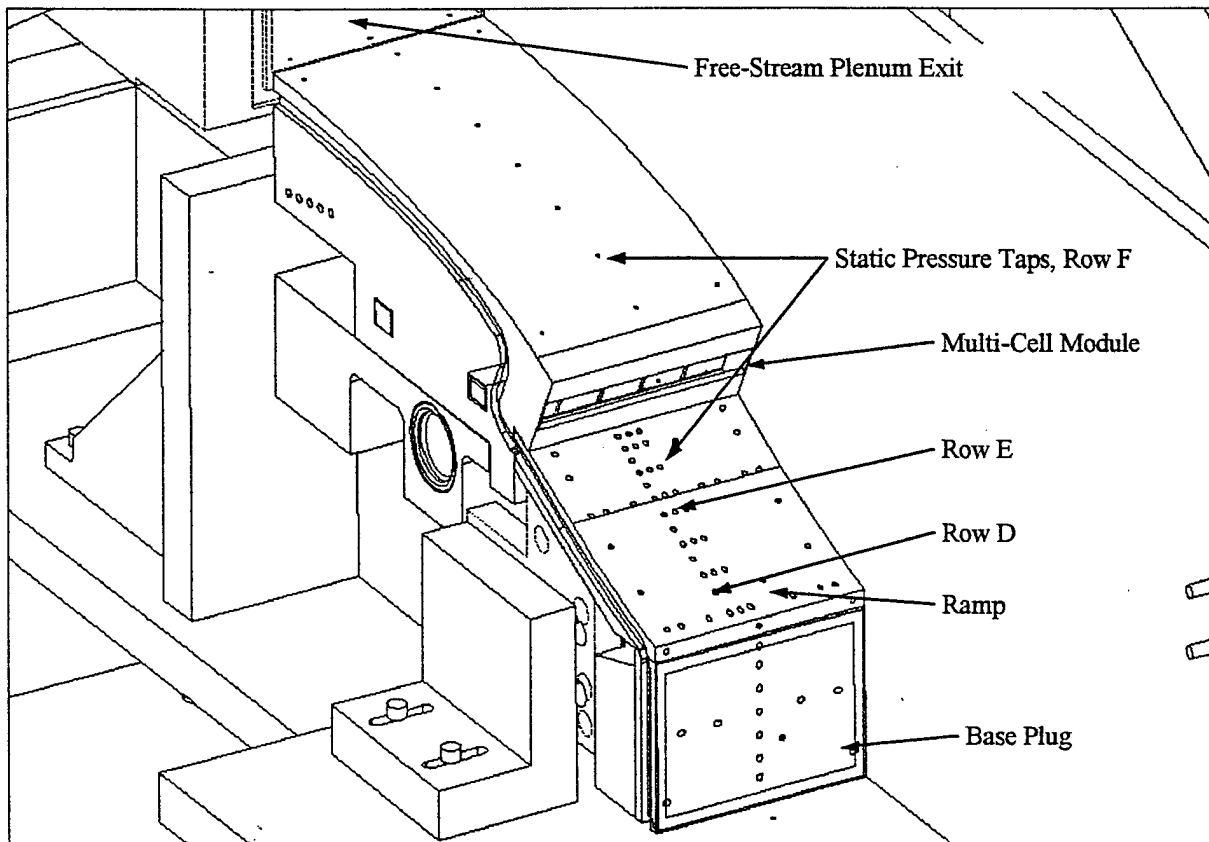

Figure 3: Multi-Cell Round-Rectangular Nozzle, Linear Aerospike, Cold Flow Model Installation

tion had good grid resolution in the gap area, but the grid grew more sparse near the center of the thrust cells. This could have been one reason for the better prediction along the gap row.

#### Thrust

A 3-D FNS (full Navier Stokes) solution was completed for the round-rectangular geometry with no base bleed and no slipstream. The solution was calculated for a very high pressure ratio of 6000. Several MOC solutions were run with varying pressure ratios. A comparison of the thrust efficiencies from the data showed that both the CFD and the MOC results over-predicted the level of thrust efficiency.

#### Base Bleed

Subsonic injection via a large open cavity was used for base bleed on the round- rectangular geometry. The base injection medium for each test was ambient GN<sub>2</sub>. For most of the pressure ratios, it appeared that base bleed flow rates between 1.0% and 2.0% generated the highest thrust efficiency. Base bleed flow rates of 3.0% actually produced a higher thrust value but a lower thrust efficiency. The thrust coefficient normalizes the thrust value by the sonic thrust contribution of the base bleed. If the base bleed flow produces less thrust than the sonic contribution, the thrust coefficient, and hence the thrust efficiency will go down. In other words, it is better to inject the propellant in the main chamber than in the base. The maximum thrust efficiency gain for base injection is on the order of 4 to 5 points. A maximum thrust coefficient of  $C_T=0.95$  (for all the tests) occurred at a pressure ratio of 800 and a base bleed flow rate of 1.0%.

#### Conclusions

1. The 2-D MOC results captured the general trend of the wall pressures.
2. 3-D effects needed to be modeled to capture the entire plug flow field.
3. The 3-D CFD modeled the 3-D effects along the gap row reasonably well, but over-predicted the centerline and quarter thrust cell rows.
4. The CFD solutions needed to have a high amount of lateral grid points in order to properly model the plug flow field.
5. The base wake flow closed at a low pressure ratio of 400 (10% DPR).
6. The CFD under-predicted the base pressure by 60%.
7. The maximum thrust efficiency for the round-rectangular thruster geometry without base bleed was 0.91.

8. The CFD and the MOC over predicted the thrust efficiency (0.953 ~~and~~ 0.955, respectively).
9. The maximum thrust efficiency occurred with a base bleed of 1 % ( $C_T= 0.95$ ).

#### Phase 4 - Advanced Level Technology Thrust Cell

Phase 4 built upon the successes of Phase 2 for the design and fabrication of an "Advanced Level Technology Thrust Cell" which featured the advanced powder metallurgy materials and processes previously noted. One Advanced Level Technology Thrust Cell combustion chamber capable of undergoing hot-fire testing was completed in December 1998.

#### Advanced Materials Development

Evaluation of advanced materials was conducted in parallel with the Advanced Processes Development task. Powders of various alloy compositions, particle morphologies, and size distributions were HIP'ed to produce P/M billets from which tensile test specimens were machined. Alloy compositions were screened using optical microscopy of the consolidated billets and tensile tests at room and elevated temperatures. Material properties testing was completed for four candidate powder metal copper alloys and three candidate powder metal stainless steel alloys. A single material combination (Cu-8Cr-4Nb liner material and 347 CRES throat support material) was downselected for fabrication of deliverable thrust cell units. Optimized P/M processing developed concurrently with the Advanced Materials Development task was applied to the downselected materials. A material property database was established for the design process, including tensile properties, low cycle fatigue, creep, and thermal conductivity.

#### Chamber Liners

Four copper alloy powders, NARloy-Z, Cu-8Cr-4Nb, Cu-2.3Cr-0.6B, and Glidcop AL-15 (copper plus 1.5% aluminum oxide) were evaluated. These powders were selected based on their high strength and high conductivity characteristics. The copper alloy material selection plan entailed initial consolidation of powders into small cylindrical billets by cold isostatic pressing (CIP'ing), followed by final consolidation by one of two hot isostatic press (HIP) cycles. Consolidated material properties were then evaluated after three different post-HIP treatments: 1) in the as-HIP'ed condition, 2) following a solution treat/age cycle, and 3) following a full thermal treatment which simulated the Advanced Level Technology thrust cell HIP bonding process. Cu-8Cr-4Nb was selected for liner fabrication due to its high strength, particularly at elevated temperatures. The powder metal materials development task proved

DEFINITION

that this material achieved equivalent or better properties than wrought NARloy-Z for the UMCC HIP bond cycle samples. Thermal conductivity was also exceptional, equivalent to wrought NARloy-Z at 600 to 1000 °F. These properties combined translated into liner design advantages of longer life, lower weight (a thinner hot wall and lands) and higher engine performance because the channels could be larger and operate hotter.

#### Throat Supports

Three iron/nickel alloy powders, A-286, JBK-75 and CRES 347 were evaluated. These powders were selected based on their high strength, resistance to hydrogen embrittlement, commercial availability, and compatibility with the potential copper liner alloys and 347 CRES jacket material to be employed in the UMCC-style chamber fabrication process. Consolidated material properties were evaluated: 1) in the as-HIP'ed condition, 2) following a solution treat/age cycle and 3) following a full thermal treatment which simulated the Advanced Level Technology thrust cell HIP bonding process.

Strong consideration was given to JBK-75 and A286 as throat support materials for fabrication of the two Phase 4 hot-fire quality deliverable thrust cells. However, subsequent structural analysis showed that the coefficient of thermal expansion (CTE) differences between the powder metal JBK-75 or A286 throat support and wrought CRES 347 jacket components would create problems during the thrust cell HIP-bond cycle. The CTE for JBK-75 and A286 fell below that of the wrought CRES 347 material. In contrast, the CTE for the powder metal CRES 347 was nearly identical to that for the wrought form which maintained the proper loading between jacket and throat support during HIP. Based on the stress analysis, powder metal CRES 347 was selected for the throat supports.

#### Advanced Process Development

Powder metallurgy processing was developed to produce near-net shape thrust cell components. Both ceramic and metallic mold fabrication were explored for the P/M process. MTDs were fabricated to assess mold stability, distortion and shrinkage characteristics, mold-to-part interactions, and mold removal techniques. Several processing sequences were evaluated including vibration and cold pressing compaction of the powders, pre-sintering steps, and consolidation by HIP and Ceracon™ processes. Optimum process parameters were established concurrently with the advanced materials development. P/M processing advantages and limitations were incorporated into the Detailed Design of the

advanced technology thrust cell. Efforts to produce hot-fire quality near-net-shape Cu-8Cr-4Nb liner preforms and associated material properties database were completed.

#### Chamber Liners

Four liner process concepts were developed and evaluated at Crucible Research. In the first concept, a free-standing HIP can configuration was designed and fabricated for producing the near-net shape copper alloy. In the second and third concepts, copper alloys were HIP'ed against solid internal (ID) mandrels to evaluate the potential for achieving a net liner hot gas wall contour. Crucible Research designed and fabricated sheet metal cans for direct HIP of a near-net shape liner. Fabrication of mild steel HIP canisters with and without solid ID mandrels was accomplished. The canisters were spun, welded and a release coating was applied to the solid ID mandrel. Following HIP consolidation, the steel canister was mechanically and chemically removed and the liners were dimensionally inspected for compliance with drawing requirements.

In the fourth concept, IMT conducted a parallel effort to fabricate a near-net-shape, powder metal Glidcop Al-15 liner. A single liner process concept was developed and evaluated at IMT. The IMT development liner was fabricated using a two-step (CIP/HIP) process in which separate, free-standing forward and aft "green" segments (split at the throat) were produced in an initial cold isostatic pressing (CIP) process then HIP'ed together onto a two-piece ID mandrel. The resulting part featured a near-net ID contour and a machined OD contour (to remove the OD HIP can). Following the CIP process, the free-standing liner "green" part was "canned" and HIP-consolidated to final dimensions. Hot isostatic pressing of the IMT near-net, powder metal (Glidcop AL-15) development article was performed on 21 March 1996. Visual inspection of the HIP'ed liner following removal of ID mandrel tooling revealed a slight crease in the liner ID throat plane. Otherwise, the part was in excellent condition. OD HIP can removal and dimensional inspection proved that the part met the design requirements. The part was shipped to Rocketdyne in May 1996.

The free-standing HIP can was selected to process the Cu-8Cr-4Nb powder because of the overall ease of fabrication, quality of the final product and because of equipment problems with the CIP process. Fabrication and dimensional inspection of HIP canisters for the final two near-net Cu-8Cr-4Nb liner preforms were completed by Crucible Research in early December 1996

DEFINE UMCC

J. r. cur

(see Figure 4). Dimensional data on both canisters was nominal (no evidence of misalignment, etc.), and the canisters were loaded with -140 mesh powder. Both parts were successfully HIP'ed, with no evidence of tilting or wrinkling. The ID contours on both liner preforms met the ID contour target with a small amount of cleanup stock allowance.



Figure 4: HIP'ed Cu-8Cr-4Nb Powder Metal Chamber Liner Preform Produced by the Free-Standing HIP Can Method

#### Throat Supports

The throat support concept developed by Crucible Research was directly analogous to the rapid prototype manifold investment casting process developed under Phase 2 of the Thrust Cell Technology Program. As in the Phase 2 manifold effort, the Phase 4 throat support fabrication process entailed ceramic slurry investment of SLS polycarbonate throat support patterns supplied by Rocketdyne. A steel sheet metal outer container and ceramic-glass particulate pressure transmitting media were used in this process. Following shell buildup and assembly, the SLS pattern was burned out and iron/nickel powder poured into the mold. The desired near-net-shape throat support component was then produced by HIP-consolidation of powder within the ceramic mold.

Three iterations were performed in the development unit using CRES 347 powder. The third iteration throat support preforms are shown in Figure 5. Dimensional inspection results for the third iteration (347 CRES material) near-net metal throat support development article indicated that the 347 CRES throat support geometry met the dimensional envelope required to final machine the near-net throat support halves for the hot-fire quality thrust cell unit.

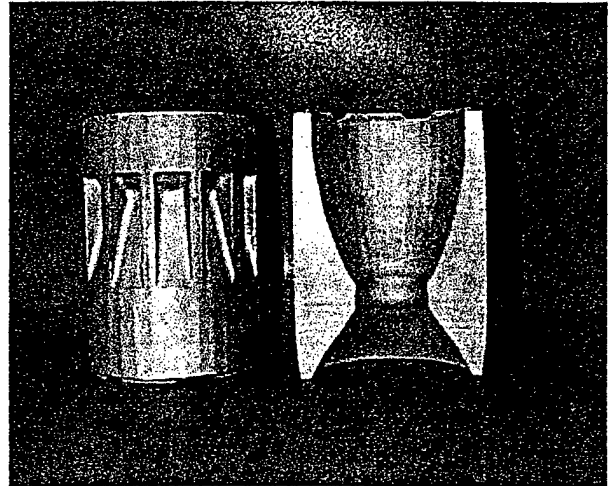

Figure 5: HIP'ed 347 CRES Powder Metal Alloy Throat Support Halves

#### Selective Laser Sintering (SLS) Support

SLS work was performed by the Rocketdyne Rapid Prototyping Lab (RRPL) in support of the Phase 4 advanced level technology thrust cell final assembly. RRPL produced the polycarbonate patterns that were required to fabricate the powder metal throat support preforms (see Figure 6). SLS was also used to fabricate the polycarbonate plating development models for the chamber liner and throat supports. These plating models were used to verify that the plating anode designs could deliver uniform plating of the desired thickness, a requirement for the chamber brazing process.

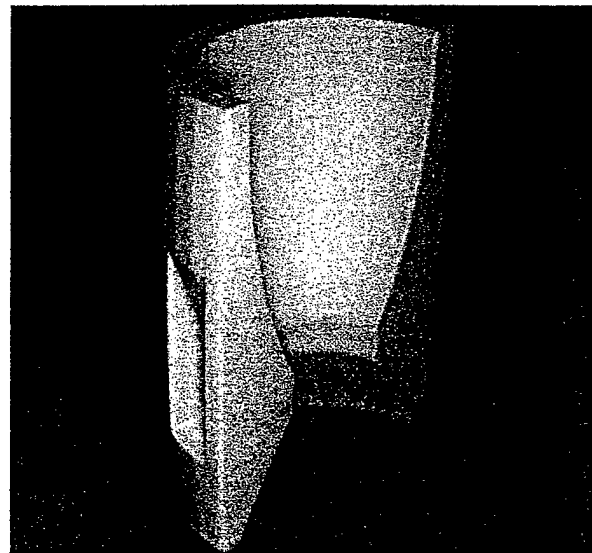

Figure 6: SLS Polycarbonate Powder Metal Throat Support Preform Pattern Ready for Investment with Ceramic Slip

LINER INVEST

### Thrust Cell Design and Fabrication

Advanced materials and processes developed under their respective subtasks were integrated into the detailed design to fabricate one, plus a spare, hot-fire quality advanced level technology thrust cell. The baseline advanced technology thrust cell was a rapid prototype P/M copper alloy liner mated to a set of P/M CRES throat supports and HIP-bonded into a structural jacket that featured cast propellant manifolds. This effort included fabrication of all thrust cell braze samples, thrust chamber components and the thrust chamber final assembly. HIP bonding of the thrust chamber sample and the deliverable thrust chamber assembly (December 1998) was completed under this task as well as thrust chamber final machining.

Cu-8Cr-4Nb braze bond samples were fabricated, brazed and evaluated. The objective of the braze bond sample tests was to evaluate the electroplating characteristics of the Cu-Cr-Nb material, and to determine the mechanical characteristics of the Cu-Cr-Nb-to-347 braze bond using Silcoro 75 braze foil and "gold-only" (gold electroplated onto the Cu-Cr-Nb bond surface) as the bonding medium. The initial set of braze bond trials consisted of bonding together two sets of one-inch cubes machined from and 347 CRES material. The cubes were electroplated to achieve plating thicknesses prescribed for "gold only" and "with (Silcoro 75) braze foil" processes. The "gold only" bond process was baselined for the Phase 4 thrust cell liner-to-jacket braze joint. Tensile bars were tested at temperatures from room temperature to 1000 °F to obtain ultimate strength value for the braze joint. These results verified that the Cu-8Cr-4Nb-to-347 CRES material combination and the baseline "gold only" bonding process were compatible with the Phase 4 thrust cell fabrication and assembly process. Simulated liner flat panel braze samples were also fabricated and tested for coolant channel geometries that represented the chamber wall, the throat region and the nozzle exit. All three samples passed proof pressure testing. As a final verification, a cylindrical braze MTD was assembled. The sample passed proof test and was ultrasonically inspected. The sample was then sectioned for metallographic evaluation and the bond joint was nominal.

The structural jacket was comprised of five component parts. The body section was a simple tube with weld preps on each end. As in Phase 2, the propellant manifolds were two-piece, welded assemblies, one forward manifold assembly and one aft manifold assembly. These two subassemblies were welded to the body tube

in Rocketdyne's Weld Lab. Both jacket assemblies (one plus one spare) were sent out for final machining of the ID contour. The final machined jacket assemblies were returned to Rocketdyne after machining for nickle plating in preparation for brazing.

The chamber liners (one plus one spare) were delivered to Hoefner Corp. for final machining. First, the ID and OD on both parts was machined. Then an ID mandrel was machined to support the liner during slotting. Once both liners were slotted, they were gold plated for the "gold-only" braze alloy system. A subsequent survey of plating thicknesses over the part surface verified that the plating thickness fell within the prescribed limits. The liners were ready for thrust chamber assembly (see Figure 7). The throat supports were then sent to

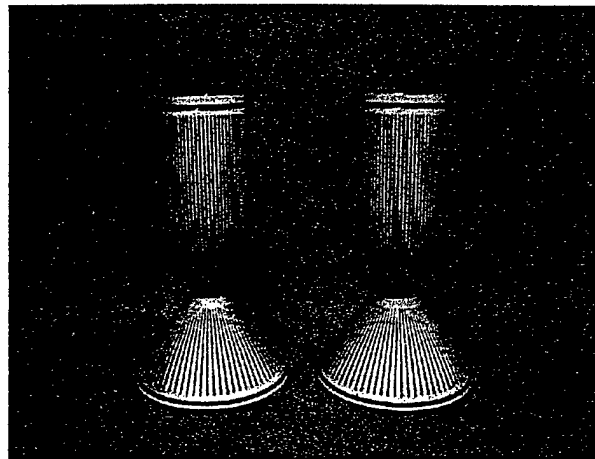

Figure 7: Cu-8Cr-4Nb Powder Metal Alloy Chamber Liners, Machined and Gold Plated

Hoefner Corp. for final machining with the chamber liners. The throat support halves were designed with one bolt on each side to hold the halves together, located over the throat plane. This allowed the throat supports to be held securely on the liner during final assembly.

In general, any Rocketdyne HIP-bonded thrust chamber assembly will include a structural jacket/manifolds, a slotted wall copper-alloy chamber liner and a set of two throat support halves as illustrated in Figure 8. The standard approach seeks to generate and maintain a compressive load at all braze surfaces, between the throat support and jacket through a shrink fit and between the liner and jacket through HIP pressure. In this application the throat supports were bonded to the jacket and each other using braze alloy foil while the liner was bonded to the backup structure using the

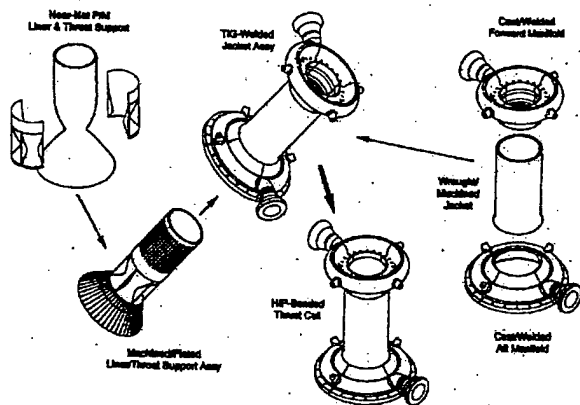

Figure 8: Rocketdyne HIP-Bonded Combustion Chamber Assembly Flow Diagram

“gold-only” alloy system.

The final assembly began with the structural jacket being heated to approximately 400 °F. The liner subassembly (see Figure 9) was suspended from an overhead crane and lowered into a dewar of liquid nitrogen. Thoroughly chilled, the liner subassembly was removed from the liquid nitrogen. The liner subassembly was moved into position directly over the structural jacket.

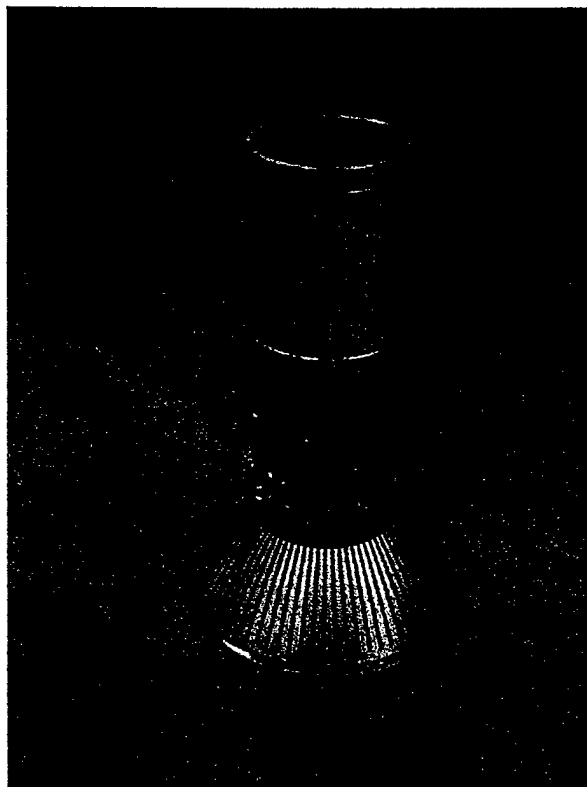

Figure 9: Chamber Liner and Throat Support Subassembly Ready for Final Assembly into the Structural Jacket

The liner was lowered rapidly into the structural jacket. Once the subassembly had fully seated, the liner aft tooling plate was clamped into place until the assembly reached room temperature.

The HIP bonding was conducted at Kittyhawk Products. The thrust chamber assembly was mounted to the furnace tooling and connected to a vacuum pump at the inlet and outlet propellant manifolds. The thrust chamber assembly was returned to Rocketdyne and final machined. The Advanced Level Technology thrust cell is shown in Figure 10.

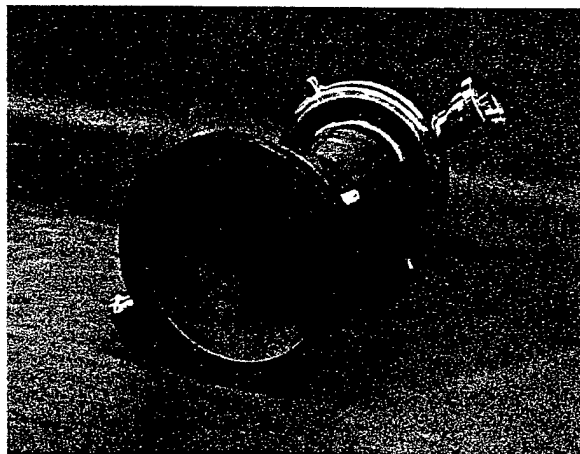

Figure 10: Completed Thrust Cell Technology Combustion Chamber

#### Phase 6 - Injector Design and Fabrication

The injector task objective was to complete the detailed design, analysis, and fabrication of a hot-fire quality, LOX/GH<sub>2</sub> injector assembly that could interface with the Phase 4 thrust chamber assembly. Fabrication of one hot-fire quality injector assembly was completed.

#### Injector Design

The injector design was comprised of two components, a structural body with integral propellant manifolds and a brazed-on, NARloy-Z copper alloy, solid faceplate featuring an impinging element, box-doublet injector pattern. Combustion performance and stability analyses, stress analysis, and aerothermal analysis of the injector design were completed as part of this effort. The injector design operating conditions match the Phase 4 thrust cell:

Chamber Pressure	2400 psia
LOX Flowrate	26.3 lbm/sec
GH <sub>2</sub> Flowrate	4.4 lbm/sec
Mixture Ratio (O/F)	6.0
Throat Diameter	1.98 inches



the Rocketdyne Rapid Prototyping Lab (See Figure 12). The six "green" or unconsolidated injector bodies were built using argon-atomized Haynes 230 powder. The green parts were consolidated using an inert gas retort in the Rocketdyne Braze Lab's atmospheric furnace. The furnace cycle used a hold to burn out the nylon binder and a hold at the peak temperature to permit maximum consolidation.

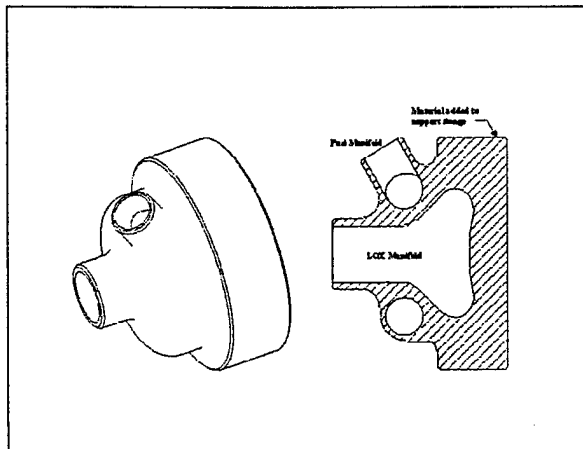

Figure12: Three Dimensional Computer Model for Fabrication of the Direct Metal Injector Body

The mechanism that allows the powder metal to consolidate is the boron additive. A small amount of boron is included in a melt of the Haynes 230 alloy. In turn, a small percentage of the powder mix for the Sinterstation is the borided alloy. The borided alloy melts at a lower temperature than the non-borided alloy. Boron has high mobility and travels readily along the grain boundaries, allowing slippage to occur along the boundaries which allows the powder metal particles to deform and coalesce. The purpose of the added hold was to give the part, which is weak after the burnout



Figure13: A "Green" Injector Body (Left), the Fully Consolidated Direct Metal Injector Body (Center), and the Hot-Fire Wrought CRES 347 Injector Body (Right)

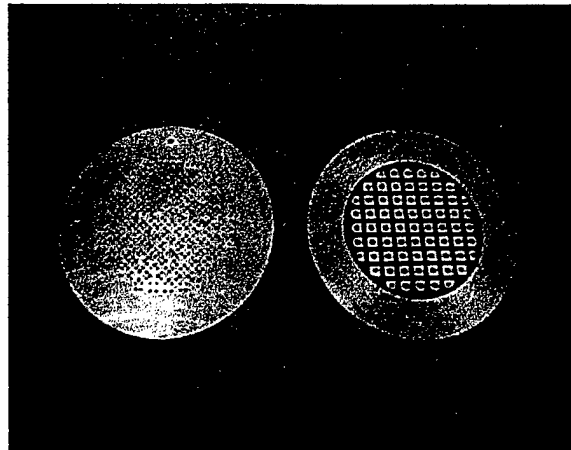

Figure14: The NARloy-Z Injector Face Plate Viewed from the Front and Back. Note the Coolant Slots in the Right Hand View.

phase, time to build strength by the above mentioned mechanism before it is taken to the full consolidation temperature. Addition of this hold brought success to the sixth and final green part. Though only approximately 94% dense, this was sufficient to allow the part to be HIP'ed and a density of 99.3% was ultimately achieved. The completed SLS preform body is shown in Figure 13.

#### Injector Assembly

Development of the SLS direct metal sintering process was successful, but completion of the final, fully consolidated injector body occurred too late to be used in the deliverable injector assembly. A wrought, machined injector body of a two-piece, welded design was fabricated as an alternate and was completed in November 1998. The machined and gold plated injector face plate is shown in Figure 14 prior to brazing. Note the

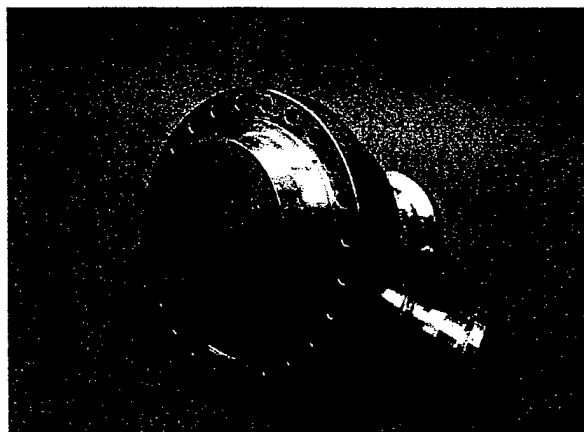

Figure15: The injector assembly after final machining, ready for hot-fire testing.

deep channels in the backside of the face plate that enhance heat transfer from the face into the hydrogen fuel. The completed injector is shown in Figure 15.

### Conclusions

The materials and process technologies developed on this program were executed successfully and were found to have numerous advantages over current practice. These include:

1) Developments in materials processing and fabrication techniques for iron, nickel and copper-based powder metal alloys.

- a) Application of an advanced powder metal copper alloy (Cu-8Cr-4Nb) for thrust chamber liner fabrication that exhibited better strength and equivalent thermal conductivity when compared to standard NARloy-Z.
- b) Development of the free-standing HIP can method for processing powder metal alloys for chamber liner fabrication.
- c) Development of powder metal processing techniques using ceramic investment mold technology as applied to the Phase 4, 347 CRES throat supports.

2) Application of Rapid Prototyping techniques to:

- a) Investment casting pattern development (Selective Laser Sintered polycarbonate). This included the successful casting of propellant manifolds for the Phase 2 and Phase 4 thrust cells and successful casting of NARloy-Z copper alloy, actively cooled thrust chamber liners.
- b) Electroplating demonstration model and shield development (SLS nylon and polycarbonate).
- c) Model fabrication for cold flow testing (SLS nylon-glass).
- d) Development of entirely new and revolutionary Rapid Prototyping techniques (SLS) for the direct fabrication of metal parts from a powder metal/binder system through subsequent furnace and HIP consolidation.

3) Design, analysis and fabrication of the highest pressure, liquid oxygen/hydrogen, *solid face plate* injector produced to date at Rocketdyne. This design afforded a substantial part count reduction (from hundreds of parts to two; the injector body and the face plate) over Rocketdyne's conventional shear coaxial injector with rigid-mesh (porous metal) face plate designs.

4) Application of the HIP (hot isostatic pressure) bonding technique to the Phase 4 thrust cell which process has been used successfully by Rocketdyne to reduce thrust chamber fabrication time.

5) Generation of an extensive database of analytical results and supporting cold flow test data for several nozzle contours singly and in multi-cell arrays.

6) The application of the Rocketdyne-developed Electrodeposited Nickel/Cobalt process to the Phase 2 manufacturing technology demonstrator combustion chamber. The Phase 6 injector body preform was successfully produced using this process.

7) Early work on the "gold-only" braze alloy system and subsequent application to the Phase 4 thrust cell.

Ultimately, the program objectives of reduced fabrication time, part count and cost were achieved for production of high performance oxygen/hydrogen thrust cells. The final thrust chamber and mating injector assembly illustrated here are hot-fire quality and currently available for testing.