

REPORT DOCUMENTATION PAGE

Form Approved
OMB No. 0704-0188

Public reporting burden for this collection of information is estimated to average 1 hour per response, including the time for reviewing instructions, searching existing data sources, gathering and maintaining the data needed, and completing and reviewing this collection of information. Send comments regarding this burden estimate or any other aspect of this collection of information, including suggestions for reducing this burden to Department of Defense, Washington Headquarters Services, Directorate for Information Operations and Reports (0704-0188), 1215 Jefferson Davis Highway, Suite 1204, Arlington, VA 22202-4302. Respondents should be aware that notwithstanding any other provision of law, no person shall be subject to any penalty for failing to comply with a collection of information if it does not display a currently valid OMB control number. PLEASE DO NOT RETURN YOUR FORM TO THE ABOVE ADDRESS.

1. REPORT DATE (DD-MM-YYYY)		2. REPORT TYPE Technical Papers		3. DATES COVERED (From - To)	
4. TITLE AND SUBTITLE				5a. CONTRACT NUMBER	
				5b. GRANT NUMBER	
				5c. PROGRAM ELEMENT NUMBER	
6. AUTHOR(S)				5d. PROJECT NUMBER	
				5e. TASK NUMBER	
				5f. WORK UNIT NUMBER	
7. PERFORMING ORGANIZATION NAME(S) AND ADDRESS(ES) Air Force Research Laboratory (AFMC) AFRL/PRS 5 Pollux Drive Edwards AFB CA 93524-7048				8. PERFORMING ORGANIZATION REPORT	
9. SPONSORING / MONITORING AGENCY NAME(S) AND ADDRESS(ES) Air Force Research Laboratory (AFMC) AFRL/PRS 5 Pollux Drive Edwards AFB CA 93524-7048				10. SPONSOR/MONITOR'S ACRONYM(S)	
				11. SPONSOR/MONITOR'S NUMBER(S)	
12. DISTRIBUTION / AVAILABILITY STATEMENT Approved for public release; distribution unlimited. MEMORANDUM FOR PRS (In-House/Contractor Publication) FROM: PROI (STINFO) 02 Feb 2001 SUBJECT: Authorization for Release of Technical Information, Control Number: AFRL-PR-ED-TP-2001-033 Bromaghim, D., et al., "An Overview of the On-Orbit Results from the Electric Propulsion Space Experiment (ESEX)" Journal of Propulsion and Power (Statement A) (Deadline: N/A) <div style="text-align: right; font-size: 2em; font-weight: bold;">20020823 037</div>					
15. SUBJECT TERMS					
16. SECURITY CLASSIFICATION OF:			17. LIMITATION OF ABSTRACT	18. NUMBER OF PAGES	19a. NAME OF RESPONSIBLE PERSON
a. REPORT	b. ABSTRACT	c. THIS PAGE			Leilani Richardson
Unclassified	Unclassified	Unclassified	A		19b. TELEPHONE NUMBER (include area code) (661) 275-5015

41 items enclosed

An Overview of the On-Orbit Results from the Electric Propulsion Space Experiment (ESEX)

D.R. Bromaghim, J. R. LeDuc, R.M. Salasovich, G.G. Spanjers, and J.M. Fife

USAF Research Laboratory

Edwards AFB, CA

M.J. Dulligan

ERC, Inc., USAF Research Laboratory

Edwards AFB, CA

J.H. Schilling and D.C. White

W.E. Research, LLC., USAF Research Laboratory

Rosamond, CA

L.K. Johnson

The Aerospace Corporation

El Segundo, CA

Present Address: The Jet Propulsion Laboratory, Pasadena, CA

Abstract

The United States Air Force (USAF) Research Laboratory's Electric Propulsion Space Experiment (ESEX) was launched and successfully operated demonstrating the compatibility

use a dash rather than a hyphen

and readiness of a 26 kW ammonia arcjet subsystem for satellite applications. ESEX is one of nine experiments on the USAF's Advanced Research and Global Observation Satellite (ARGOS). Data were acquired to characterize the thruster in four different areas: electromagnetic interactions, contamination effects, optical properties of the plume, and thruster system performance. The results demonstrated that the critical system components (including the arcjet, power processor, and propellant system) operated well, and verified the interoperability of high power electric propulsion with generic satellite operations.

Introduction

The Electric Propulsion Space Experiment (ESEX) was a space demonstration of a 26 kW ammonia arcjet sponsored by the USAF Research Laboratory, with TRW as the prime contractor. The experiment objectives were to demonstrate the feasibility and compatibility of a high power arcjet system, as well as measure and record flight data for comparison to ground results.¹⁻³ The on-board flight diagnostics included four thermo-electrically-cooled quartz crystal microbalance (TQCM) sensors, four radiometers, a section of eight gallium-arsenide (Ga-As) solar array cells, electromagnetic interference (EMI) antennas, a video camera, and an accelerometer. ESEX is one of nine experiments on the USAF's Advanced Research and Global Observation Satellite (ARGOS). ARGOS was launched on 23 Feb 99 from Vandenberg AFB, CA on a Delta II into its nominal orbit of approximately 457 nmi (846 km) at 98.7° inclination.⁴⁻⁵ Once on-orbit, the satellite was operated from the Research and Development, Test and Evaluation (RDT&E) Support Complex (RSC) at the USAF Space and Missile Test and Evaluation Directorate at Kirtland AFB, NM

The ESEX flight system, Figure 1, includes a propellant feed system (PFS),⁶ power subsystem⁷ including the power conditioning unit (PCU)⁸ and the silver-zinc battery, commanding and telemetry modules, the on-board diagnostics,¹ and the arcjet assembly.⁸ ESEX was designed and built as a self-contained experiment to minimize the impact of any effects from the arcjet firings on ARGOS. This design allowed ESEX to function semi-autonomously, requiring ARGOS support only for attitude control, communications, radiation-hardened data storage, and housekeeping power for functions such as battery charging and thermal control.

The ESEX flight operations focused on scheduling firings concurrent with observable passes over ground-based sensors in northern California and Maui, Hawaii. The eight firings were executed mostly without incident, and the arcjet, PCU, and PFS performed well. Ultimately, however, a battery anomaly occurred that precluded further firings.

Data from all of the on-board diagnostics were collected for each of firing. Ground-based measurements were performed for several of the firings as well. In general, the performance of the thruster was nominal and, while there were measurable effects observed, none of the on-board or remote diagnostics indicated any issues with integrating high power electric propulsion onto spacecraft. Furthermore, none of the firings showed any negative effect on the ARGOS operations.

This paper describes the flight operations, followed by a summary of the science data results, and concludes with a discussion of the two anomalies experienced during the mission. Companion

papers discuss the design and development of the arcjet, PCU, and associated hardware, as well as the science results in detail.⁹⁻¹⁴

Flight Operations Overview

Pre-Launch Activities - After a substantial test and evaluation program of the ARGOS spacecraft,¹⁶ the satellite, with ESEX integrated, was shipped to Vandenberg AFB for launch. After a functional verification was performed, ARGOS was mated to the Delta II to complete the final launch preparations. A series of tests were conducted while the vehicle was in this configuration including several functional verification tests, ESEX and ARGOS battery maintenance, and a communications compatibility verification with the Air Force Satellite Control Network (AFSCN).

Launch Attempts - There were a total of ten scrubbed launch attempts, the bulk of which resulted from inclement weather. The weather violations were dominated by winds aloft that either exceeded the maximum loading requirements on the Delta II fairing, or that would have created a potential hazard for falling debris on populated areas. The vehicle was ultimately launched successfully at 10:29:55 Z on 23 Feb 99. The Delta II placed ARGOS within 1% of the nominal orbit at an altitude of 456.9 nmi (846.2 km), and an inclination of 98.73°, corresponding to an orbital period of 101.6 minutes.

Phase I Operations - After the successful launch and initial acquisition and stabilization, the operations focused on verifying that the spacecraft bus and all of the experiments, including

ESEX, were fully operational. ARGOS completed its nominal initialization except for two issues. The first was a propensity of the Global Positioning System (GPS) receiver to drop out of the navigation mode - the method by which a position and velocity solution are determined. This behavior was eventually traced to a signal-to-noise problem, but eliminated the planned use of the receiver by ESEX as one technique to measure arcjet performance.³ This problem was partially resolved after the ESEX operations were complete by uploading a software patch to the ARGOS flight computer.

The second issue was a recurrence of a ground test anomaly, and manifested itself as an inability to perform ranging, commanding, and telemetry downlink simultaneously with the AFSCN standard uplink power and command modulation index. The issue was mostly eliminated early in Phase I by modifying the standard uplink power and command modulation index at each AFSCN site, until a satisfactory communications link was established. The problem did appear periodically throughout the remainder of the ESEX mission, however, and hampered some of the electromagnetic test objectives.

The first ESEX activity following turn-on was to initialize the TQCMs and begin cooling these mass-deposition sensors in order to characterize the vehicle outgassing. Comparing the ARGOS outgassing rate with that of other vehicles¹⁵ can provide a quantitative measure of the effects of cleanliness standards during spacecraft fabrication on eventual contamination risks in flight.

On day 2, approximately 26 hours after launch, the vehicle received an incorrect GPS initialization vector and went into a "sunsafe" mode - a safe mode that inertially points the

arrays at the sun and turns off all unnecessary power loads. This configuration optimizes the chances of survival given an anomaly of unknown origin. The cause here, however, was a known problem (an incorrect initialization vector) and the recovery process was started immediately.

Phase I continued approximately 48 hours later, and it was during this time that the first of two ESEX anomalies were observed. As a part of the power reduction procedure that is executed when ARGOS enters sunsafe mode, a series of lower heater setpoints are triggered for the ESEX electronic boxes. This includes the battery panels, which have thermostatically controlled bleed resistors designed to dissipate the battery charge following the end of Phase II. These resistors were engaged as a result of all sunsafe events, requiring battery charging immediately following the completion of the sunsafe recovery. During the first of these charging cycles, high oscillations on the battery charger output were observed when the battery voltage approached -225 Vdc. The arcjet and battery are connected to charge to negative voltages with the anode at ground potential. This behavior, and the impact to the ESEX mission, is discussed in a later section on flight anomalies.

After verifying that the anomalous charger-circuit behavior was not detrimental to the flight unit, the ESEX battery charging was continued. The remainder of the ESEX initialization and checkout was completed, which included a verification of all of the electronic boxes, the thermal control system, and the command sequences used to control the majority of the ESEX operations.¹⁶ The ESEX EMI boom was deployed on day 14, later than originally planned.¹⁶ The deployment was delayed to allow additional outgassing data to be collected from TQCM

sensor #4, located on the EMI boom, while it was pointed at the ESEX diagnostic deck in the stowed position. Once the initialization activities were successfully completed, ESEX and ARGOS were declared ready to support experiment operations, and Phase II began.

Phase II Operations - Phase II was dedicated to two primary experiments^{4,5} - ESEX and the Critical Ionization Velocity (CIV)⁴ experiment. The original operations plan called for integrating ESEX firings with CIV releases for the duration of the mission. This plan did not prove logistically feasible on-orbit due to a shorter amount of time between ESEX firings than planned, coupled with weather and instrument problems at the ground observation sites. The modified experimental plan did not significantly affect either the CIV or ESEX mission success.

The first ESEX activity in Phase II was to perform a series of outflows from the PFS, first of gaseous nitrogen (GN_2), and then of ammonia (NH_3) while monitoring the ESEX and ARGOS state of health telemetry. These activities are summarized in Table 1. The objective of these outflows was four-fold: (1) to bleed the GN_2 blanket from the plenum tank; (2) to verify the operation of the PFS; (3) to verify that the arcjet cold flow thrust would not have a detrimental effect on the ARGOS attitude control system; and (4) to measure any off-axis thrust (which there was none). The GN_2 outflow was performed by opening the arcjet valve without activating the PFS algorithm, the software method by which flow to the arcjet is actively controlled.⁹ The outflow was conducted over two passes, to allow enough time to evacuate the plenum tank pressure to < 1 psia. The NH_3 release was planned in the same pass as the second GN_2 release (R-2), but was aborted by the ESEX computer when an overly conservative, self-imposed software limit on the PFS temperature was exceeded. This temperature limit is one of several

ESEX inputs that allow the operator to establish control parameters within which the ESEX computer must function. The ESEX computer compares the measured value with the user-established limit 30 times/second, and aborts all operations, and safes the system, if that limit is ever violated. In cases such as R-2 release attempt, the limit was too constraining, which was somewhat expected prior to launch, since it only represented the operators' best estimate of the on-orbit considerations. The second NH_3 release attempt (R-3) was executed successfully with a more relaxed, but acceptable limit, exhibiting nominal behavior except for a momentary ingestion of a slug of liquid NH_3 at the initialization of the PFS algorithm. This is discussed in detail in a later section on flight anomalies.

The ingestion of liquid NH_3 at the initialization of the PFS algorithm was unexpected since it was not observed in any ground tests (subsequent analyses indicated that it could have occurred, but may not have been observed). While the liquid ingestion was brief and confined to the initial valve pulse, it occurred for every outflow except the last firing (F-8). This minor problem was overcome by implementing an operational delay after opening the arcjet valve, which allowed the plenum tank to "dry out" and the flow to stabilize before starting the arcjet. The duty cycle of the flow control valve - the dual pressure control (DPC) valve (reference Figure 10 for the PFS schematic) - showed a large control margin. In fact, the measured flow rate was often within ± 0.3 mg/sec of the setpoint (reference Figure 2), well within the specified requirement of ± 5 mg/sec.

Once the PFS operation was verified, the arcjet firings were initiated. The firings were all conducted over two ground sites to facilitate ground-based observations.^{3,20} These two sites are

the 1.6-m telescope at the Maui Space Surveillance Site (MSSS) for optical observations⁹ and the Camp Parks Communications Annex (CPCA) in Dublin, CA for the communication experiments.¹² A brief summary of all of the arcjet firings is included in Table 1.

The first two firing attempts (F-1A and F-1B) were aborted due to overly conservative software constraints, similar to the experience on the first NH₃ outflow. These initial adjustments to the ESEX system were not unexpected, and did not reflect system behavior that was anomalous or out of specification. Subsequent data review showed the arcjet actually ignited on the first firing attempt (F-1A) on the tenth start pulse, but was aborted within 2-3 seconds due to a mass flow rate limit that was too tight for the ramp-up phase. The second firing attempt (F-1B) was aborted by a temperature software limit prior to the arcjet start command.

The need for ten start pulses to ignite the thruster on the first attempt is consistent with ground test experience, where multiple start pulses were often used. Additionally, flight experience with other arcjets has typically shown the first on-orbit ignition to be slightly more difficult than all subsequent starts, possibly due to oxidation or slight, unavoidable contamination of the cathode from ground handling, cleanliness levels, etc. Interestingly, all subsequent firings ignited on the first pulse, validating the work done early in the program to ensure reliable arcjet starts.¹⁷⁻¹⁹ The first successful arcjet firing (F-1C) was completed after a thorough review of all software limits. The planned duration for the first firing was four minutes,^{16,20} but was terminated after 141 seconds because the contact support for this orbit pass was ending, mostly as a result of the delay from the liquid ingestion. This firing was performed over CPCA, which passively acquired data

on the ARGOS transmission spectra. The results acquired from CPCA are discussed briefly below, and detailed by Dulligan et al.¹²

Subsequent firings proceeded much in the same manner as F-1C. The mass flow rate for the remaining firings was increased, however, since the arcjet power appeared higher than the nominal 26 kW. Later analysis indicated this was not the case as summarized below and discussed in detail by Fife et al.¹³ Figure 2 illustrates a typical operational data set for a firing, in this case from firing F-4 on 23 Mar 99. As shown in Figure 2, all of the demonstration components (the arcjet, PCU, and PFS) operated well, typically well within the specifications set forth at program initiation. The liquid ingestion and the drop in battery output voltage can also be seen in Figure 2, which ultimately caused the arcjet to shut off since it was below the acceptable PCU input voltage.

Battery charging was conducted between each of the firings, which, as described above, were scheduled on high elevation passes at either MSSS or CPCA. This scheduling philosophy maximized the opportunities to collect data from the ground-based observations, but limited the duration of each firing by limiting the amount of charging between each event.

Phase II proceeded with seven more ESEX firings and the CIV releases. The ESEX flight unit performed flawlessly, in spite of minor issues with the PFS liquid ingestion, battery voltage fluctuations, and some telemetry issues with the arcjet current and inlet pressure. Each of the issues was ameliorated with relatively simple operational work-around procedures and had no detrimental effects on the ESEX or ARGOS system performance. Ultimately, however, the

battery failed completely, eliminating any chance of further ESEX firings. Since this failure occurred within days of the scheduled end of Phase II and the majority of science data had been collected, the result was only a minor impact on the overall mission success. Once the battery condition was stabilized, ESEX was placed into a long-term discharge configuration for the Phase III portion of the ARGOS mission. The battery discharge was completed in July, 1999, but the flight unit power remained on until August, 2000 while contamination and electromagnetic data continued to be collected.

Science Results Summary

Although the mission was shortened somewhat by the battery failure, there was still an enormous amount of data collected during this unique opportunity. The science data was divided into sections corresponding to the scientific objectives and the specific sensors.^{3,20} These areas are optical observations, electromagnetic interactions, performance, and contamination measurements.¹¹⁻¹⁴

Optical Observations - The optical observations were made from a ground-based sensor, the 1.6-m spectrograph/telescope at MSSS, and an on-board sensor, the still frame video camera.⁹ The objective of these observations was to characterize the emitting excited states both from a spectroscopic and spatial perspective. Emission more than a few millimeters from the nozzle arises from recombination and consequently the measurement environment is expected to be significant to the observations. The ESEX flight was the first opportunity to observe a high-

power plume expansion under molecular flow conditions, since ground emission measurements have all been performed at considerably higher background pressure.

Spectroscopic data were expected to yield information about the energy distribution of excited states and thus contribute to the overall understanding of losses in the arcjet. The specific intent was to closely examine the NH (A-X) transition at moderately high resolution in an effort to determine vibrational and rotational temperatures. The spectroscopic data also include continuum emission from the hot arcjet nozzle which can be compared to nozzle temperatures measured in ground test. A very small subset of the anticipated ground-based spectroscopic data were obtained during the flight campaign. The single firing usefully observed recorded arcjet emission over the spectral range 320-670 nm at low resolution. In addition, poor weather conditions during the observed pass make unambiguous spectral intensity calibration difficult, and unfortunately the spectral resolution is not high enough to make the best estimates of the NH temperatures. However, the principal features observed from the flight agree with ground tests, namely, atomic hydrogen lines dominate the line spectrum, along with the NH complex at near-UV wavelengths; and the emission lines sit on top of a greybody continuum rising to the red end of the spectrum.

The video camera provided a verification of normal arcjet operation and was partly intended as a diagnostic for anomalous operation. More important, however, was the expectation that the video images would reveal the extent of the emitting part of the plume to be smaller than that observed on the ground, since a small recombination volume is expected in space. Finally, the images were expected to confirm temporal and spatial aspects of arcjet nozzle heating models.

The on-board camera acquired images during each of the eight firings with several different shutter speed settings. The limited number of arcjet firings precluded testing over the full dynamic range of the camera, leading to the majority of the full-power images exceeding the maximum intensity range of the CCD detector. A survey of images of the arcjet during the first 90 seconds of operation illustrates the rapid heating of the anode and extent of the plume. Part of this series is shown in Figure 3, which shows the startup and most of the 70-second ramp to full power. The lack of steady-state images precluded quantitative correlation of arcjet thermal models to the on-orbit data, but the results did qualitatively confirm the expectation of the smaller plume extent.

Electromagnetic Interactions - The impacts of a 26 kW arcjet on spacecraft communications and operations have always been a major integration concern. A series of tests were performed during the ESEX mission to address as many of these areas as possible. Tests included measurements from the on-board EMI antennas, communication bit error rate (BER) tests to quantify the effect of the arcjet on the ranging signal, and uplink/downlink tests to qualitatively verify the communication link integrity. The results from the uplink/downlink test, and other qualitative results from the performance of the ARGOS sub-systems, all indicate the arcjet firings had no deleterious effect on the ARGOS operations.¹²

The on-board EMI antennas measured the radiated emission from the arcjet in the lower gigahertz communication frequencies (e.g., S-band, X-band, etc.) The antennas sample 2, 4, 8, and 12 GHz signals with a $\pm 5\%$ bandpass filter on each channel. Data were gathered on the

antennas for each of the firings, during quiescent spacecraft periods, and during routine spacecraft operations. The firing and non-firing data sets were then compared to identify any effects from the arcjet operation. The antenna measurements during arcjet firing periods did not differ from non-firing data, and correspond well with measurements made during ground tests.²¹

The BER test enabled a quantified assessment of the effect of the arcjet on the satellite ranging channel. This test is performed by replacing the normal ranging pattern with a test pattern from CPCA and determining the number of bit errors on the return signal using a BER counter.^{3,12,20} A series of baseline measurements were made while the arcjet was off, and with the vehicle in several transmit configurations for comparison with firing data. Figure 4 shows a representative data set from the BER tests with an arcjet firing vs. a baseline measurement. These data were recorded at transmit rates of 1.024×10^6 bits/sec, with typical error rates less than 2 bits in 10,000. It should be noted that the CPCA system was significantly de-tuned in order to increase the sensitivity of the measurement. During routine satellite operations, the BER is typically less than 1 in 1×10^6 bits.

In total, three arcjet firings and over thirty baseline BER curves were recorded during the ESEX flight. Analyses did not reveal a clear correlation between features observed in the arcjet firing curves and the operation of the arcjet, since similar features are identifiable in both baseline and arcjet firing curves.

Performance - The arcjet performance was measured by three different techniques: an on-board accelerometer, AFSCN tracking, and the ARGOS GPS receiver.¹³ Although there were some

issues with both the accelerometer and the GPS data as described below, the ΔV derived from each of these techniques agree to within 1%. This correlation suggests that these data accurately represent the thruster performance.

The on-board accelerometer data were collected for all eight firings. There are a number of uncertainties in the thrust derived from the acceleration measurement, dominated by the systematic uncertainties associated with the accelerometer, PFS, and PCU. Figure 5 shows the mean Isp for the firings plotted against the ground test data on the engineering model hardware. Data analyses suggest the arcjet current telemetry was repeatedly reading approximately 6% high.¹³ Since this cannot be absolutely confirmed, the data presented in Figure 5 are uncorrected for the higher power readings. This figure does show, however, the mean of the corrected performance as an illustration of the effect of the 6% difference.¹³ In summary, the measured Isp was 786.2 ± 43.0 seconds, the efficiency was 0.267 ± 0.021 , and the thrust was 1.93 ± 0.06 N.

AFSCN tracking is typically used for spacecraft orbit determination in support of nominal satellite operations. For the ESEX mission, these data were also used to determine the performance of the thruster by comparing the orbit solutions before and after a firing. This technique provided an independent verification of the thruster performance by measuring the total ΔV imparted to the spacecraft. Table 2 summarizes the results of the eight firings derived from this ground tracking data and compares these with the data obtained from the accelerometer and the GPS receiver.

Since the GPS receiver experienced some difficulty on-orbit, limited data were acquired. These data only allowed a gross performance comparison, rather than time-resolved analysis of the thrust profile. As can be seen in Table 2, results agree well with the AFSCN tracking and the accelerometer where the three data sets are all available.

Contamination Measurements - An array of sensors were positioned at strategic locations around the ESEX diagnostic deck (reference Figure 1) in order to assess the contamination effects of the arcjet firings.¹⁴ Mass deposition, which can impact satellite optical and thermal control surfaces, is measured using four TQCMs. Thermal flux from the arcjet firing is measured using four radiometers coated with S13-GLO, a common thermal surface material with low solar absorptivity and high emissivity. Measurement of heat transfer through the coating identifies the degradation of the S13-GLO when subjected to the spectral emission of the high-power arcjet. Any such degradation would affect the thermal design of spacecraft using high-power arcjets for propulsion. A sample Ga-As solar array segment was placed near the arcjet nozzle and used to determine the potential for plasma/solar array interactions or obscuration of the solar flux, which can have a deleterious impact on satellite power generation capability.

During eight firings of the ESEX arcjet, no measurable material deposition is observed on the TQCMs that is attributable to the steady-state operation of the arcjet. Material is collected on the sensor nearest the thruster exit plane (TQCM sensor #1) on the first firing, however the lack of similar collection on subsequent firings or on any of the other sensors suggests this material was a one-time efflux indicative of the fabrication and handling, and not indicative of steady-state contamination rates. TQCM sensor #2, which is not in the line-of-sight of the arcjet body or the

plume, shows essentially no effect from the firings. Surprisingly, the TQCM sensors within this line-of-sight generally show a removal of previously deposited mass with each firing, presumably as a result of heat flux from the arcjet causing vaporization of previously collected material.

Figure 6 shows a summary of the maximum heat flux measured by the radiometers during the arcjet firing portion of the mission. Radiometer #1, placed near the thruster exit with a view of both the arcjet plume and body, shows an increase in the heat flux during this period, indicating a degradation of the sensor material from the arcjet firings. The other radiometers, which have no view of the arcjet, or a view of only the plume, show less degradation as a result of the arcjet firings.

Solar cell segments placed near the thruster exhaust show a degraded performance, seen as a temporary drop in open circuit voltage, during the initial portion of the ramp-up phase of each firing, which worsened as the mission progressed. This degradation is attributable to the arcjet exhaust plasma partially shorting the solar cell load. A plot of the solar cell V-I curve is shown in Figure 7, further illustrating this effect and showing the decrease in performance as the mission progressed - each firing causing further degradation from the non-firing baseline illustrated in the top half of the figure. The solar array measurements also show a 3% decrease in power generation over the 60-day period in which the arcjet was fired, attributable to degradation in the solar transmissivity of the cover glass material. No deleterious effects associated with the arcjet firings were observed on the main ARGOS solar arrays.

In general the ESEX results are very promising for the integration of high power electric propulsion on commercial and government satellites. Although degradation associated with contamination is observed, in each case the effect is observed only on sensors placed near the exhaust nozzle. It is unlikely that material or sensors would be located this close to the arcjet exit plane in a fully-developed, high power electric propulsion system. Contamination sensors located in the backplane of the arcjet, or behind the thermal shield, show no deleterious effects.

Flight Anomalies

The two anomalies discussed in detail below are a battery failure that ultimately led to the conclusion of the ESEX mission, and an observation of liquid ingestion in the PFS. The observed data are discussed, followed by a discussion of the proposed causes and resultant fixes, if applicable.

Battery Anomaly - The first signs of anomalous behavior in the battery were observed during the first charging cycle, shortly following the first ARGOS sunsafe event. The charging circuit operated nominally (except for a lower output current than expected) until the battery voltage approached -225 Vdc. At this point, as shown in Figure 8, the output current from the charging circuit began cycling on and off, resulting in oscillations of the open circuit battery voltage. These oscillations are believed to be a result of higher-than-expected internal battery impedance, perhaps exacerbated by a low charging-circuit output current. In an attempt to lower the charging-circuit impedance, high-capacitance filters were switched into the circuit via high voltage relays connecting the battery with the PCU.^{7,8} Although this procedure decreased the

frequency of the oscillations, it did not eliminate them entirely. Since this instability was not detrimental to the ESEX battery or the spacecraft bus, the charging continued through these oscillations, and the charging inefficiencies were accounted for by extending the total charging time. Subsequent charge cycles showed increasingly degraded stability that caused the charging circuit to shut off prior to attaining a full state of charge.

Beginning on F-4, further anomalous behavior on the battery output appeared which resulted in limited firing duration. This was manifested as a low battery output voltage while firing the arcjet, resulting in unstable PCU and arcjet operation, and eventually extinguished the arc. It should be noted, however, that the voltage at which the arc extinguished was less than -150 Vdc, which was well below the lower PCU specification limit of -160 Vdc. As can be seen in Table 1, the duration of each firing after F-4 steadily decreased, as the battery performance deteriorated. On F-7, the arcjet cycled on and off twice due to the command logic in the PCU, with both firings having extremely short durations. After this event, an attempt to recondition the battery was performed by executing a deep discharge through the battery bleed resistors¹⁶ and restarting the charge. The initial plan was to wait until the battery was at a full state of charge (indicated by the charger circuit shutting off at the upper charge limit) before attempting the next firing. After 19 days passed without an automatic shutoff, the charger was commanded off and a firing was attempted. Unfortunately, as can be seen by the short duration of F-8, the reconditioning did not have the desired effect.

Following the completion of F-8, the battery voltage fluctuated erratically between -175 and -200 Vdc with periodic drops as low as -30 Vdc, where it eventually stabilized. This behavior lasted

approximately 24 hours until, as subsequent analysis revealed, the battery sub-assembly on panel #1 (reference Figure 1) had a catastrophic failure. This failure was most likely a result of electrolyte leakage from one of the cells, causing a short circuit to the battery case. As the energy in the cell was discharging through the short circuit, there was a corresponding, dramatic increase in battery temperature, coupled with an increase in pressure as hydrogen gas was generated from decomposition of the electrolyte. This process continued until there was a breach of the battery case and a release of this super-heated gas internal to the ESEX flight unit. This gas was eventually vented into space, causing a dramatic attitude disturbance on the vehicle, resulting in a sunsafe event. A discussion on the contamination effects from the battery venting is described elsewhere.¹⁴

An analysis of the failure was conducted,²² however the exact cause of the battery problem could not be fully determined since the flight data do not present a complete picture of the anomaly. There was, almost certainly, a combination of effects that ultimately describe the observed data set. Recent data show, for instance, a significant increase in the impedance of a Ag-Zn battery as it approaches a full state of charge at a low charge rate - which would explain the charger instabilities, but not the ultimate failure. Some phenomenon was responsible for rupturing at least one of the battery cells and causing electrolyte to leak out and short to the battery case. It is also likely that some of the electrolyte was vented from the battery cells during launch as the flight unit de-pressurized, and also as the high current firings were conducted. This expelled electrolyte could have led to a variety of problems such as degraded mechanical connections or bridging the two cell electrodes and causing a short. In any case, although this battery was pushed beyond its normal operating characteristics, it was still able to deliver eight successful

firings. In hindsight, a different battery and battery charger design might have been more appropriate for this high discharge/low recharge rate application.

As mentioned above, the battery failure occurred within days of the planned completion of Phase II, and therefore did not greatly affect the science data return. The primary result was a reduced number of firings observed from MSSS, which reduced the amount of arcjet firing spectra. Although this loss accounted for almost half of the missing mission data set (10% out of 24%), the impact to the overall mission success was small. In terms of the demonstration aspects of the mission, the battery was not critical since an operational system would be powered directly from the spacecraft power system. The critical demonstration components, the arcjet, PCU, and PFS, all operated successfully.

PFS Liquid Ingestion - The liquid ingestion was initially observed on the first successful NH_3 outflow (R-3, Reference Table 1). Upon initiation of the PFS algorithm, evidence of a single slug of liquid NH_3 ingested into the plenum tank was observed on the initial DPC valve cycle. Figure 9 illustrates the issue for a typical outflow (note that the plenum tank pressure output saturates at 100 psia). As can be seen, the plenum tank temperature decreases by greater than 60 °F within 15 seconds of initiating the PFS algorithm, indicating that liquid NH_3 is expanding into the plenum tank. Approximately five minutes later, the plenum tank pressure and temperature indicate a super-heated condition and drying out of the liquid in the plenum tank as some of the NH_3 vapor is vented through the open arcjet valve (indicated in Figure 9 by the label "Begin outflow at 160 mg/sec"). A flow meter immersion thermistor located just upstream of the arcjet shows no corresponding drop in temperature, indicating that the liquid is confined to

the plenum tank and never passed to the arcjet, even prior to arc initiation. To ensure that no two-phase flow reached the arcjet, however, the arcjet start was delayed until a dry plenum was achieved in all cases. After this initial ingestion, all PFS temperatures and pressures indicate no liquid was passed to the plenum tank or arcjet for any of the outflows or firings.

A schematic representation of the PFS is shown in Figure 10. The operational profile is presented in detail elsewhere^{6,16} but basically consists of two heating periods prior to the outflow - one at t-17 hours, and one within minutes of the firing. This first heating period is to ensure sufficient pressure in the propellant tank to support flow, and the second is to heat the system to ensure the impending outflow to the arcjet is vaporized. The PFS algorithm is started just before the firing and controls the NH₃ flow rate by cycling the DPC valve to maintain pressure in the plenum tank corresponding to the specified flow rate. As a result of the software encoding, however, the DPC valve is cycled once at the start of the PFS algorithm regardless of the plenum tank pressure.

PFS heater performance prior to the outflows indicated that the bulk of the ammonia liquid remained away from the outlet of the propellant tank as the design intended. This was accomplished by differential heating of the propellant tank poles and was possibly aided by the angular momentum of the spacecraft in orbit. During the NH₃ outflow, and throughout the mission, temperatures of the enhanced feedline heater (EFH) indicated relatively little liquid entering the EFH, and 100% vapor outflow at the exit.

The liquid ingestion appears to be the result of a cold spot in the propellant line somewhere between the EFH and the DPC valve, likely a result of a cooler mounting platform than experienced during test. This platform temperature is not actively controlled, and can drift significantly, perhaps leading to a low enough temperature to condense NH_3 at the pressure in the propellant line. This cold spot allows NH_3 to condense and collect just upstream of the DPC valve. As described above, when the PFS algorithm is initiated, the DPC valve is cycled once, which releases this slug of liquefied NH_3 into the plenum tank resulting in the behavior described above. These data are supported by the fact that liquid ingestion was never observed during any steady-state operations of the PFS. To further support this hypothesis, there were some variations from the normal procedure on the last firing (F-8) and no liquid ingestion was observed. For this firing, the PFS heaters were turned on several days before the firing attempt while waiting for the battery reconditioning to complete. This increased the overall flight unit temperature 10-20 °F and may have eliminated the cold spot in the propellant line.

The liquid ingestion phenomenon was not readily observed in any of the ground tests. Initially, there were some minor differences between the flight operations profile and the ground test, primarily the heater setpoints and timing, but ultimately the flight profile was changed to mirror the test flow. This did not, however, alleviate the problem. Further modifications were made to the flight profile (mostly adjusting heater setpoints) but none of these changes proved successful either.

In summary, the liquid ingestion proved to be an annoyance, but did not seriously detract from the arcjet operation. If the ESEX mission had continued, a heater configuration that alleviated

this problem would almost certainly have been identified. Other than this issue, the PFS performed within specification and, in general, operated exceptionally well. The flow rate control generally operated to within ± 0.3 mg/sec at steady-state conditions, which was more than an order of magnitude better than the requirement of ± 5 mg/sec. If this system evolved into an operational flight design, some heater power applied to the section of the propellant line in question, or more direct thermal control of that section, could almost certainly resolve the liquid ingestion issue entirely - especially in light of the results from the last firing.

Conclusions

The ESEX flight demonstrated high power electric propulsion is compatible with satellite operations. All data show the thruster and the high power components have no significant, deleterious effect on any satellite activities.

Summary

ESEX is the culmination of over ten years of effort to validate high power electric propulsion on-orbit and verify its compatibility with standard USAF satellites. There were a total of eight firings conducted over the course of the 60-day mission, all of them over 26 kW, for a total duration of 2,023 seconds. There were two anomalies associated with the flight operations - a liquid ingestion problem that had only a minor affect on the mission, and a battery failure that precluded any further firings. Approximately 76% of the ESEX mission success was attained, with the biggest deficiencies resulting from the lack of a complete optical signature

characterization, and the lack GPS data. All of the demonstration aspects of the experiment were completed, and all of this hardware - the arcjet, PCU, and PFS - operated well, and within their specifications. All of the data indicate the thruster operated nominally, and operated completely independently of the normal operations of the host spacecraft.

Acknowledgments

The authors would like to extend their gratitude to the USAF Research Laboratory support team including LtCol Jim Zimmerman, Maj Dwayne Matias, Scott Engelman, Alan Sutton, Bill Hargus, Ron Spores, Shaughn Tracy, Krystin Barker, Rickie Rexroade, and Robin Lowder. We also extend our thanks to Mary Kriebel, Don Baxter, Bob Tobias, David Lee, and David Huang of TRW for their technical expertise on the ESEX flight hardware; and to Andy Hoskins, Bob Kay, and Joe Cassady of Primex Aerospace Company for their technical insight into the arcjet, PFS, and PCU. We would also like to extend our sincere gratitude to the ARGOS program office and the entire flight operations team at Kirtland AFB, NM, as well as the staff at MSSS and CPCA for their technical expertise, as well as their insight into and flexibility with their facilities. This "out-of-the-box" mentality allowed ESEX to acquire such a broad range of data.

References:

1. Kriebel, M. M. and Stevens, N. J., "30-kW Class Arcjet Advanced Technology Transition Demonstration (ATTD) Flight Experiment Diagnostic Package," AIAA Paper 92-3561, July 1992.

2. Sutton, A. M., Bromaghim, D. R., and Johnson, L. K., "Electric Propulsion Space Experiment (ESEX) Flight Qualification and Operations," AIAA Paper 95-2503, July, 1995.
3. LeDuc, J. R., et. al., "Performance, Contamination, Electromagnetic, and Optical Flight Measurement Development for the Electric Propulsion Space Experiment," AIAA Paper 96-2727, July, 1996.
4. Turner, B. J. and Agardy, F. J., "The Advanced Research and Global Observation Satellite (ARGOS) Program," AIAA Paper 94-4580, September 1994.
5. Agardy, F. J. and Cleave, R. R., "A Strategy for Maximizing the Scientific Return Using a Multi-phased Mission Design for ARGOS," American Astronautical Society Paper 93-594, August 1993.
6. Vaughan, C. E., and Morris, J. P., "Propellant Feed Subsystem for a 26 kW Flight Arcjet Propulsion System," AIAA Paper 93-2400, June, 1993.
7. Biess, J. J. and Sutton A. M., "Integration and Verification of a 30 kW Arcjet Spacecraft System," AIAA Paper 94-3143, June 1994.
8. Vaughan, C. E., Cassady, R. J., and Fisher, J. R., "Design, Fabrication, and Test of a 26 kW Arcjet and Power Conditioning Unit," International Electric Propulsion Conference Paper 93-048, September, 1993.

9. Cassady, R.J., Hoskins, W.A., Vaughan, C.E., Aadland, R.S., Morris, J.P., Kay, R.J., and Fisher, J.R., "The Development and Flight Qualification of a 26 kW Arcjet Propulsion Subsystem," submitted to *Journal of Propulsion and Power* Special Issue on the ESEX flight.
10. Kriebel, M. M. et al, "System Engineering, Design, Integration and Flight Qualification of the ESEX Flight Experiment," submitted to *Journal of Propulsion and Power* Special Issue on the ESEX flight.
11. Johnson, L.K., Spanjers, G.G., Bromaghim, D.R., LeDuc, J.R., Salasovich, R.M., Zimmerman, J.A., Sutton, A.M., Fife, J.M., Hargus, W.H., Spores, R.A., Dulligan, M.J., Schilling, J.H., and White, D.C., "First Results From Optical Diagnostics Applied to the Air Force Electric Propulsion Space Experiment (ESEX)," AIAA Paper 99-2710, June, 1999. Submitted to *Journal of Propulsion and Power* Special Issue on the ESEX flight.
12. Dulligan, M.J., Zimmerman, J.A., Salasovich, R.M., Bromaghim, D.R., and Johnson, L.K., "Electromagnetic Effects of the ESEX 26 kW Ammonia Arcjet on Normal Spacecraft Operations," AIAA Paper 99-2708, June, 1999. Submitted to *Journal of Propulsion and Power* Special Issue on the ESEX flight.
13. Fife, J.M., LeDuc, J.R., Sutton, A.M., D.R. Bromaghim, Chart, D., Hoskins, W.A., Vaughan, C.E., and Johnson, L.K., "Preliminary Orbital Performance Analysis of the Air Force

Electric Propulsion Space Experiment (ESEX) Ammonia Arcjet," AIAA Paper 99-2707, June, 1999. Submitted to *Journal of Propulsion and Power* Special Issue on the ESEX flight.

14. Spanjers, G.G., Schilling, J.H., Engelman, S.F., Bromaghim, D.R., and Johnson, L.K., "Preliminary Analysis of Contamination Measurements from the ESEX 26 kW Ammonia Arcjet Flight Experiment," International Electric Propulsion Conference Paper 99-038, 26th IEPC, October, 1999. Submitted to *Journal of Propulsion and Power* Special Issue on the ESEX flight.

15. Wood, B.E., Hall, D.F., Lesho, J.C., Uy, O.M., Dyer, J.S., and Bernard, W.T., "MSX Satellite Flight Measurements of Contamination Deposition on a CQCM and on TQCMs," AIAA Paper 97-0841, January, 1997.

16. Bromaghim, D.R. and Sutton, A.M., "Electric Propulsion Space Experiment Integration and Test Activities on the Advanced Research and Global Observation Satellite," AIAA Paper 96-2726, July, 1996.

17. Aadland RS, Vaughan CE, Hoskins WA and Kay RJ. "Achieving Reliable, Repeatable Starts of a 26 kW Arcjet" IEPC 93-049, 23rd IEPC, September, 1993.

18. Tilley, D.L., McFall, K.A., Castillo, S., Andrews, J.C., and Bromaghim, D.R., "An Investigation of the Breakdown Characteristics of a 30 kW Class Ammonia Arcjet," AIAA Paper 93-1901, June, 1993.

19. Tilley, D.L., "Propellant Breakdown Mechanisms in an Arcjet," International Electric Propulsion Conference Paper 93-050, September, 1993.

20. Salasovich, R.M., Bromaghim, D.R., and Johnson, L.K., "Diagnostics and Flight Planning for the US Air Force Phillips Laboratory Electric Propulsion Space Experiment (ESEX)," AIAA Paper 97-2777, July, 1999.

21. Johnson, L.K., Rivera, A., Lundquist, M., Sanks, T.M, Sutton, A.M., and Bromaghim, D.R., "Frequency-domain Electromagnetic Characteristics of a 26 kW Ammonia Arcjet," AIAA Paper 93-2393, June, 1993.

22. Bromaghim, D.R., "Battery Failure on the Electric Propulsion Space Experiment (ESEX)," to be published as a High Accident Potential (HAP) Report by US Air Force Space and Missile Systems Center.

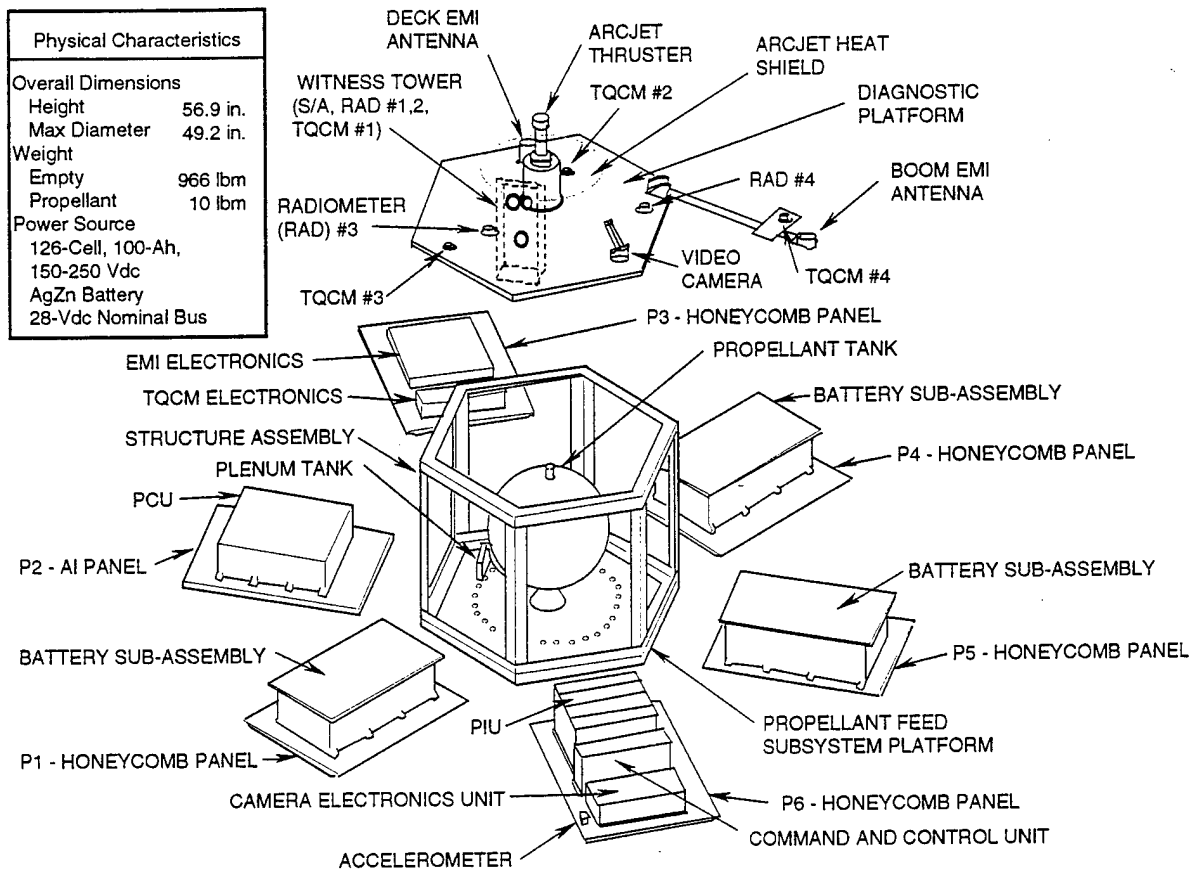

Figure 1

Bromaghim et al., J. Spacecraft and Rockets, Figure 1 of 10

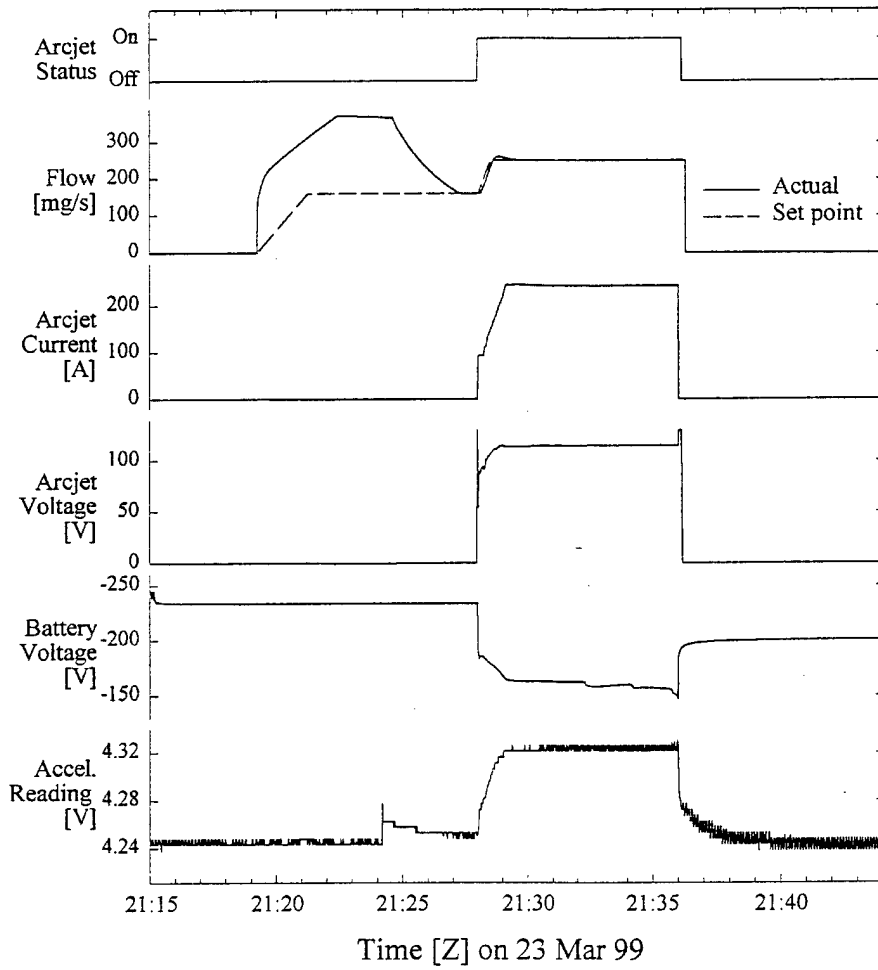

Figure 2

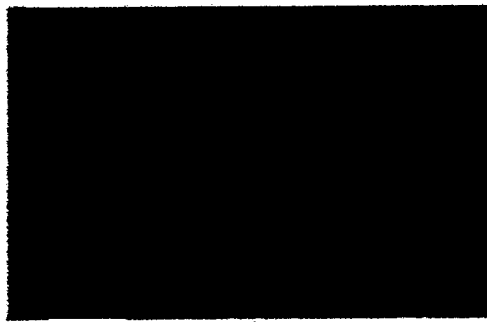

Image #1 - Acquired at $t + 15$ sec



Image #3 - Acquired at $t + 45$ sec

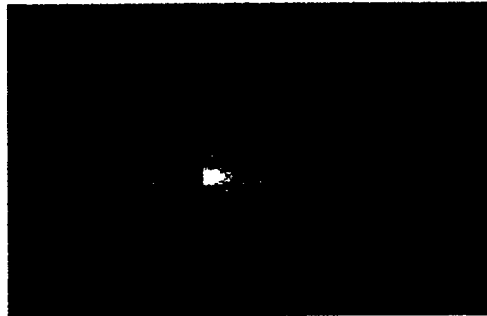

Image #2 - Acquired at $t + 30$ sec

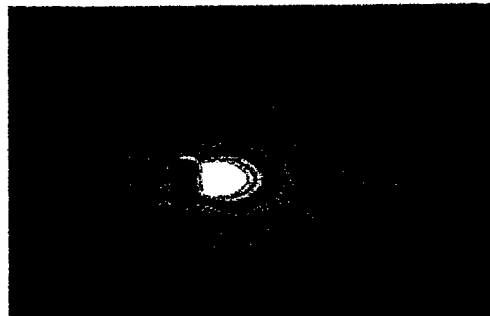

Image #4 - Acquired at $t + 60$ sec

Figure 3

Bromaghim et al., J. Spacecraft and Rockets, Figure 3 of 10

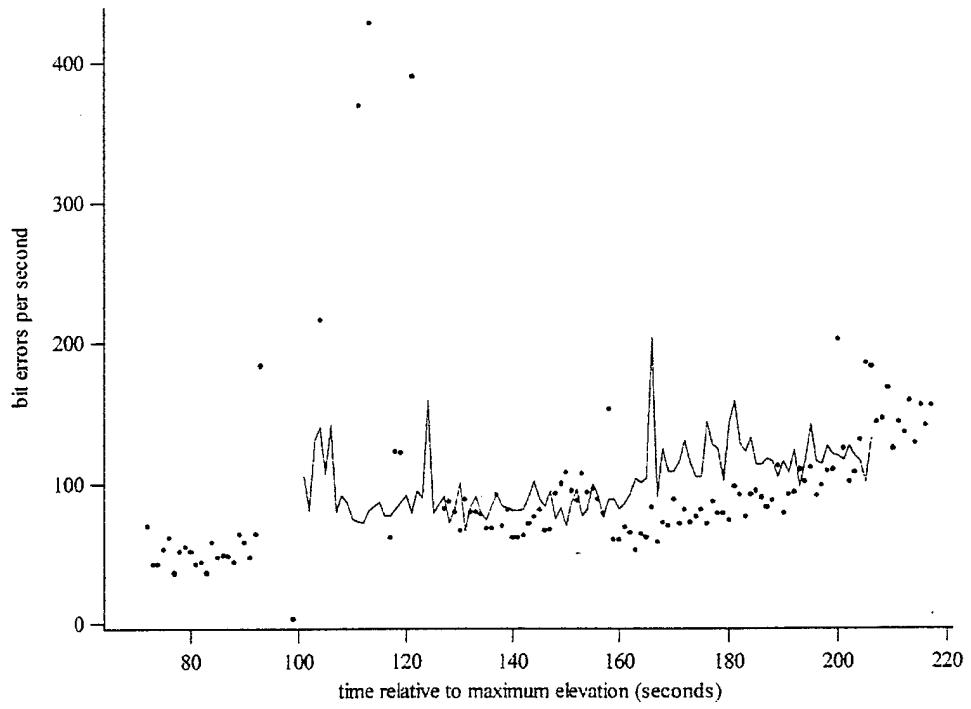

Figure 4

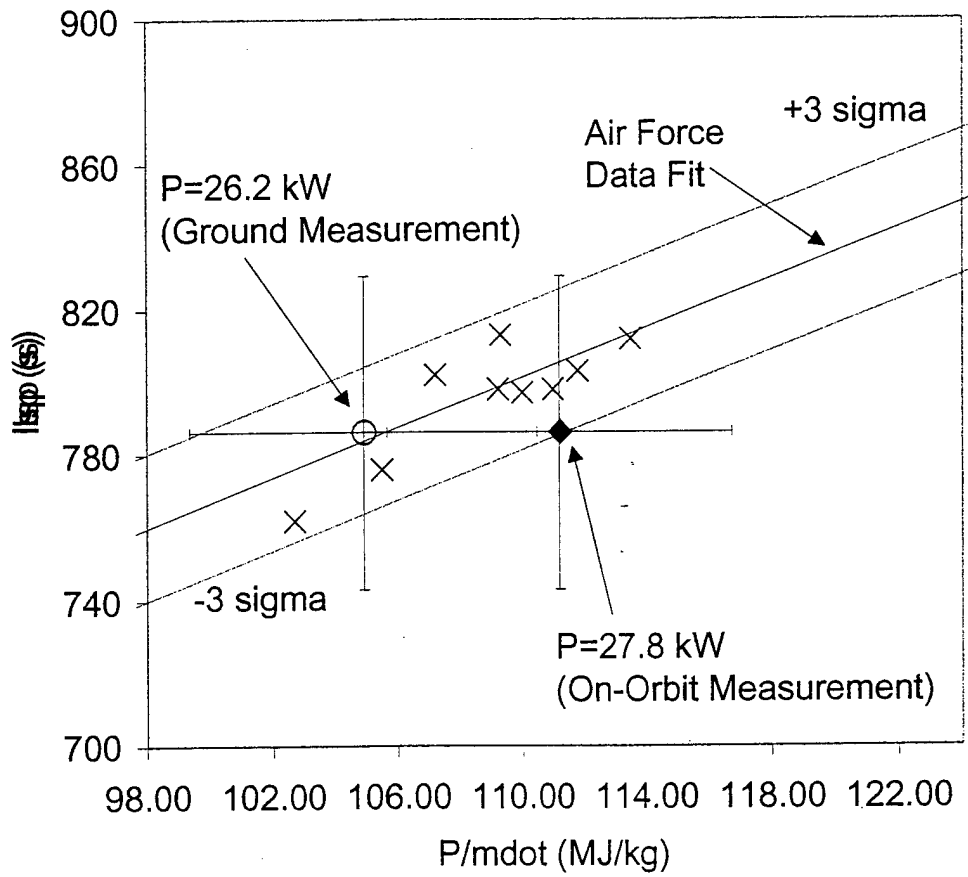

Figure 5

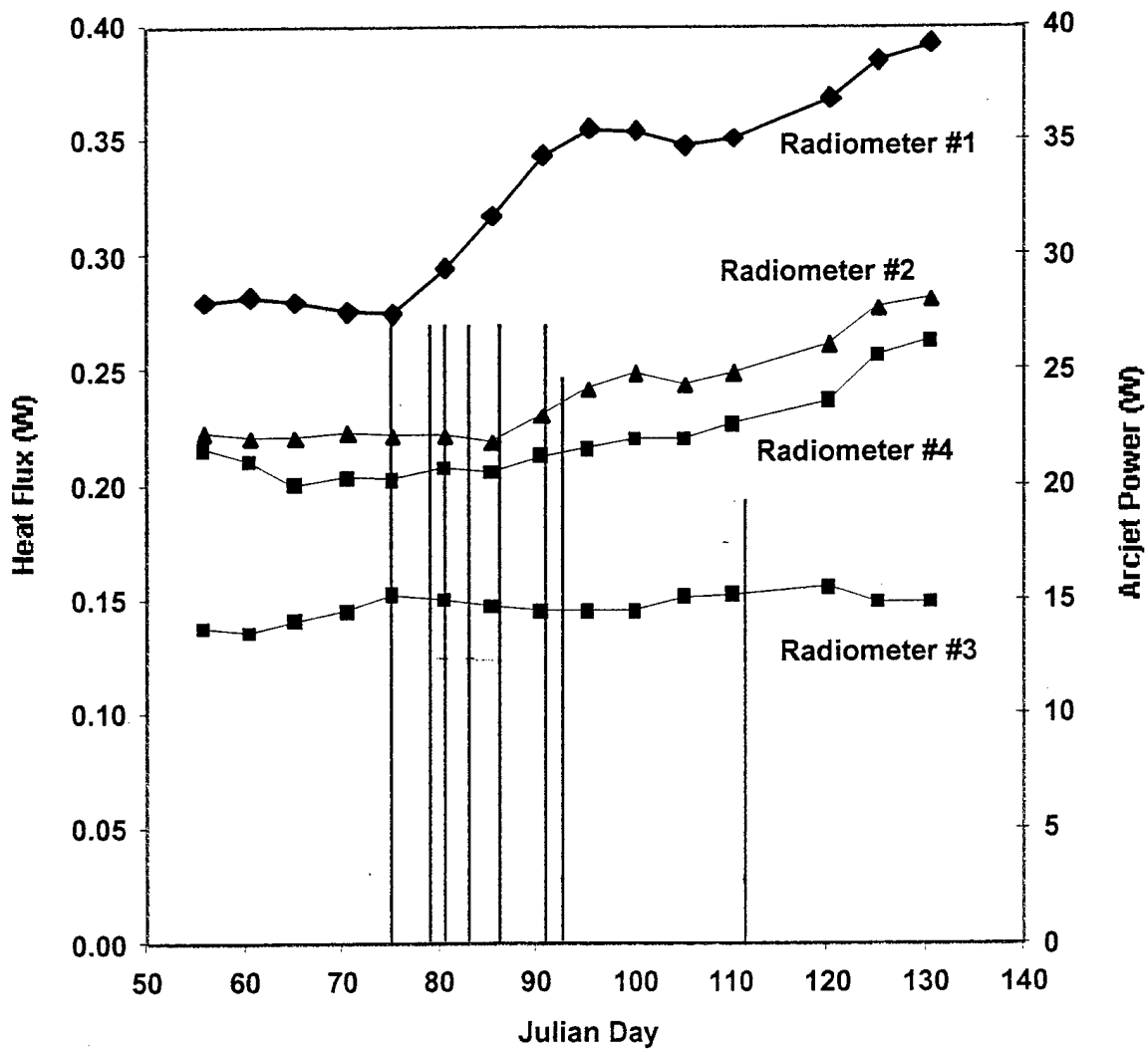

Figure 6

Bromaghim et al., J. Spacecraft and Rockets, Figure 6 of 10

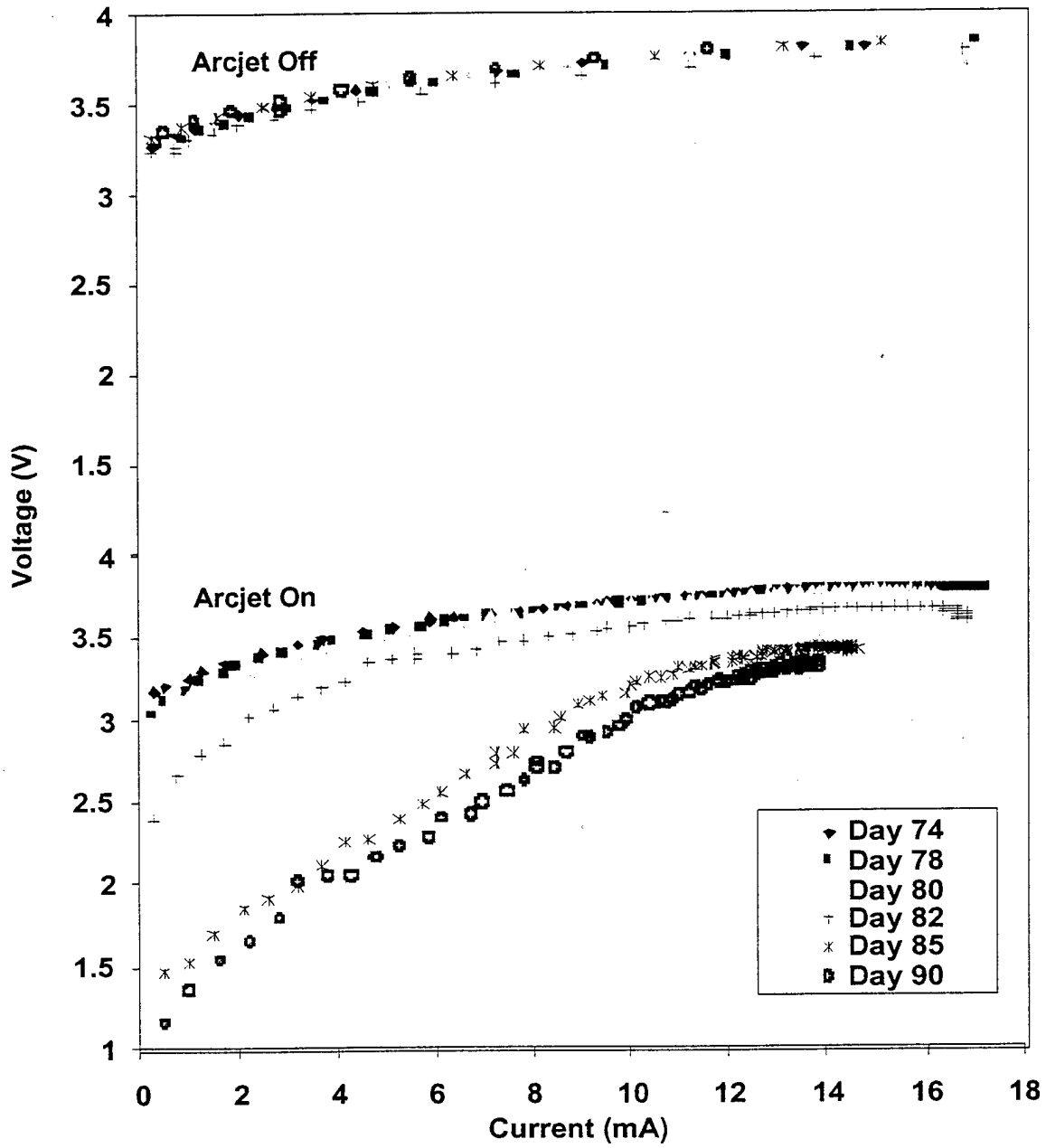

Figure 7

Bromaghim et al., J. Spacecraft and Rockets, Figure 7 of 10

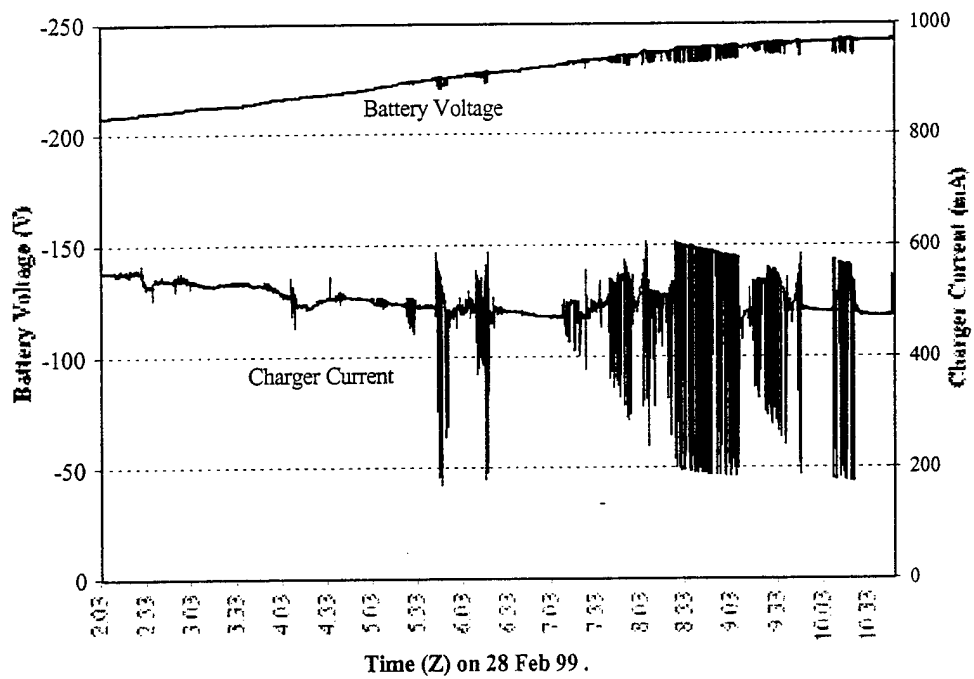

Figure 8

Bromaghim et al., J. Spacecraft and Rockets, Figure 8 of 10

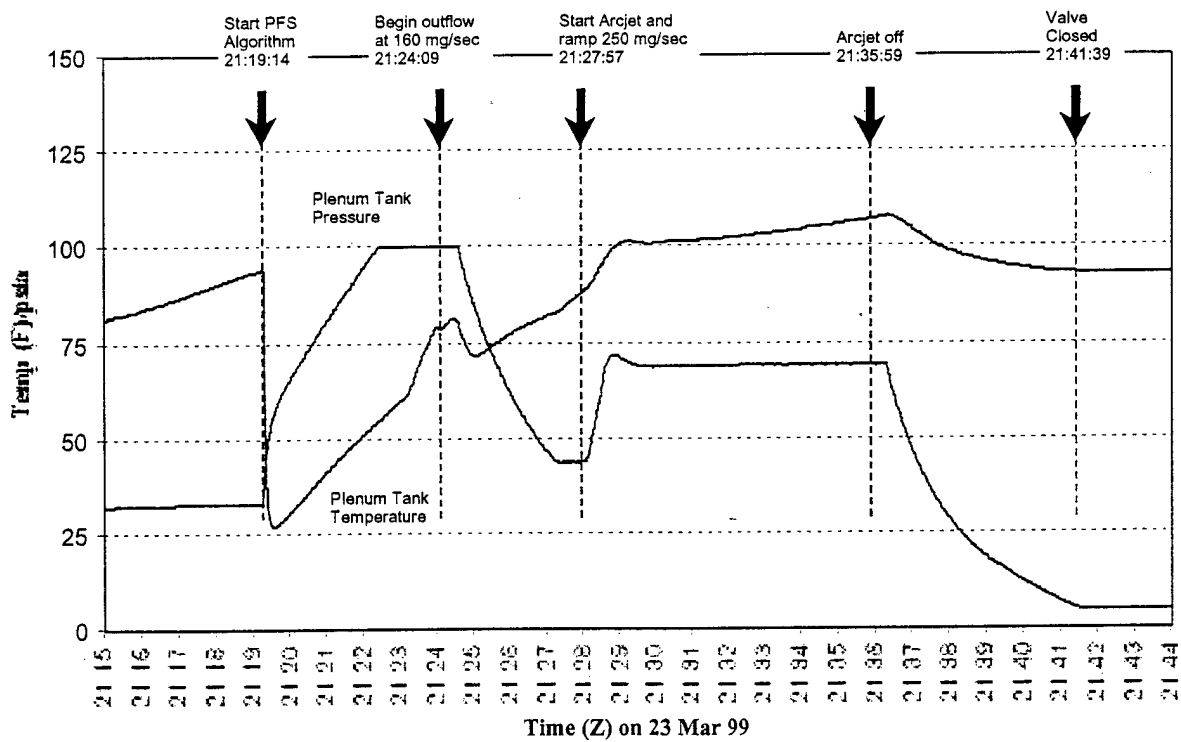

Figure 9

Telemetry Outputs

Propellant Tank Temperature, Pressure (T7A, T7B, P1)

EFH Temperature (T9A, T9B)

Plenum Tank Temperature/Pressure (T8, P2)

Flow Rate Temperature/Pressure (T1, P3)

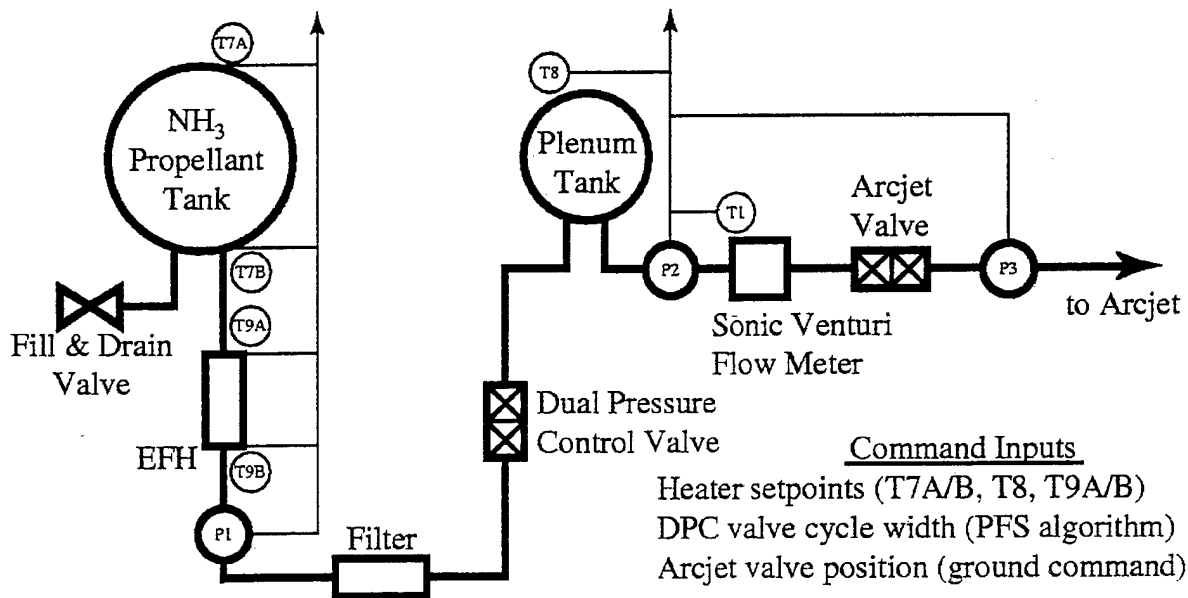

Figure 10

Table 1

Firing (F) or Release (R) No	Date/Time	Duration	Location	Comments
R-1 (GN ₂)	11 Mar 99 1928 Z	8:29 (509 sec)	Not observed	Initial GN ₂ bleed required majority of pass.
R-2 (GN ₂ /NH ₃)	12 Mar 99 0027 Z	1:13 (73 sec)	Not observed	GN ₂ bleed completed. NH ₃ aborted due to overly conservative software constraints on PFS heaters.
R-3 (GN ₂ /NH ₃)	12 Mar 99 1258 Z	1:59/3:59 (119/239 sec)	Not observed	All systems operated nominally. Liquid ingestion first observed.
F-1A	13 Mar 99 1240 Z	N/A	MSSS	First arcjet ignition (on 10 th start pulse) - firing aborted due to overly conservative software constraints on mass flow rate.
F-1B	15 Mar 99 1210 Z	N/A	MSSS	Firing attempt aborted due to overly conservative software constraints on PFS heaters.
F-1C	15 Mar 99 2155 Z	2:21 (141 sec)	CPCA	Modified firing sequence to account for liquid ingestion and ensure vapor outflow to arcjet. CPCA performed passive data collection.
F-2	19 Mar 99 2232 Z	5:01 (301 sec)	CPCA	Flow rate setpoint increased to 250 mg/sec. All systems operated nominally. CPCA acquires first active data set.
F-3	21 Mar 99 1224 Z	5:33 (333 sec)	MSSS	All systems operated nominally. No MSSS data acquired due to inclement weather.
F-4	23 Mar 99 2127 Z	8:02 (482 sec)	CPCA	All systems operate nominally except for low battery output voltage - causes arcjet to shut off early. First indication of battery trouble.
F-5	26 Mar 99 2145 Z	5:04 (364 sec)	MSSS	Low battery voltage forces early termination. Telemetry problem makes operating arcjet difficult. MSSS acquires first space-based arcjet firing spectra.
R-4 (NH ₃)	30 Mar 99 0636 Z	9:54 (504 sec)	N/A	Attempted PFS heater modifications to eliminate liquid ingestion do not succeed.
F-6	31 Mar 99 1305 Z	4:30 (270 sec)	MSSS	Low battery voltage forces early termination. Telemetry problem reduced by increasing ground transmitter power. No firing spectra acquired.
F-7A/B	2 Apr 99 2209 Z	53 sec/38 sec	CPCA	Attempt to discharge battery as much as possible prior to reconditioning. Arcjet stopped/re-started due to PCU command logic. CPCA acquires start and stop transient data.
R-5 (NH ₃)	9 Apr 99 1548 Z	9:06 (456 sec)	N/A	Further attempts to eliminate liquid ingestion with PFS heater modifications do not succeed.
F-8	21 Apr 99 1222 Z	42 sec	MSSS	Battery reconditioning has no effect on arcjet firing time. No MSSS data acquired. No liquid ingestion observed.

Bromaghim et al., J. Spacecraft and Rockets, Table 1 of 2

Table 2

Firing	Accelerometer	Ground Tracking	GPS
1	.1089 ± .0207	.11011 ± .0129	.110 ± .003
2	.2590 ± .0244	.25123 ± .0129	N/A
3	.2850 ± .0273	.27304 ± .0129	N/A
4	.4010 ± .0327	.40348 ± .0129	N/A
5	.3203 ± .0303	.32819 ± .0129	N/A
6	.2275 ± .0217	.22789 ± .0129	N/A
7	.0626 ± .0177	.06363 ± .0129	N/A
8	.0248 ± .0137	.02304 ± .0129	N/A

Bromberg et al., J. Spacecraft and Rockets, Table 2 of 2

Figure Captions:

Figure 1 - Exploded view of the ESEX flight unit

Figure 2 - Typical operational profile of an arcjet firing showing the ramp to full power and steady-state operation

Figure 3 - Series of images acquired from the on-board video camera showing the ramp to full power (t=0 represents the time the arcjet was started)

Figure 4 - Representative bit error rate data for firing #2 (dots) with baseline pass taken under similar conditions (line)

Figure 5 - Summary of the arcjet on-orbit mean performance showing the corrected and uncorrected results

Figure 6 - Radiometer peak heat flux measurements during the ESEX firings (the eight arcjet firings are indicated by the vertical lines)

Figure 7 - Summary of the solar cell V-I performance during the arcjet firings

Figure 8 - Typical battery charging circuit instability

Figure 9 - Typical PFS performance showing liquid ingestion into the plenum tank

Figure 10 - Schematic representation of the propellant feed system

Table Captions:

Table 1 - Summary of ESEX arcjet firings and propellant releases

Table 2 - Total velocity change, ΔV (m/s), during firings as measured by the accelerometer, ground tracking, and the GPS receiver