

**AFRL-PR-WP-TP-2002-203**

**FUEL-COOLED THERMAL  
MANAGEMENT FOR ADVANCED  
AERO ENGINES  
GT-2002-30070**



**He Huang, Louis J. Spadaccini, and David R. Sobel**

**JUNE 2002**

**Approved for public release; distribution is unlimited.**

**Copyright © 2002 by ASME**

This work is copyrighted. The United States has for itself and others acting on its behalf an unlimited, paid-up, nonexclusive, irrevocable worldwide license. Any other form of use is subject to copyright restrictions.

**20020926 091**

**PROPULSION DIRECTORATE  
AIR FORCE RESEARCH LABORATORY  
AIR FORCE MATERIEL COMMAND  
WRIGHT-PATTERSON AIR FORCE BASE, OH 45433-7251**

# REPORT DOCUMENTATION PAGE

*Form Approved*  
OMB No. 0704-0188

The public reporting burden for this collection of information is estimated to average 1 hour per response, including the time for reviewing instructions, searching existing data sources, gathering and maintaining the data needed, and completing and reviewing the collection of information. Send comments regarding this burden estimate or any other aspect of this collection of information, including suggestions for reducing this burden, to Department of Defense, Washington Headquarters Services, Directorate for Information Operations and Reports (0704-0188), 1215 Jefferson Davis Highway, Suite 1204, Arlington, VA 22202-4302. Respondents should be aware that notwithstanding any other provision of law, no person shall be subject to any penalty for failing to comply with a collection of information if it does not display a currently valid OMB control number. **PLEASE DO NOT RETURN YOUR FORM TO THE ABOVE ADDRESS.**

<b>1. REPORT DATE (DD-MM-YY)</b> June 2002		<b>2. REPORT TYPE</b> Conference Proceedings		<b>3. DATES COVERED (From - To)</b>	
<b>4. TITLE AND SUBTITLE</b> FUEL-COOLED THERMAL MANAGEMENT FOR ADVANCED AERO ENGINES GT-2002-30070				<b>5a. CONTRACT NUMBER</b> F33615-97-D-2784	
				<b>5b. GRANT NUMBER</b>	
				<b>5c. PROGRAM ELEMENT NUMBER</b> 62203F	
<b>6. AUTHOR(S)</b> He Huang, Louis J. Spadaccini, and David R. Sobel				<b>5d. PROJECT NUMBER</b> 3048	
				<b>5e. TASK NUMBER</b> 05	
				<b>5f. WORK UNIT NUMBER</b> EW	
<b>7. PERFORMING ORGANIZATION NAME(S) AND ADDRESS(ES)</b> United Technologies Research Center 411 Silver Lane East Hartford, CT 06108				<b>8. PERFORMING ORGANIZATION REPORT NUMBER</b>	
<b>9. SPONSORING/MONITORING AGENCY NAME(S) AND ADDRESS(ES)</b> Propulsion Directorate Air Force Research Laboratory Air Force Materiel Command Wright-Patterson Air Force Base, OH 45433-7251				<b>10. SPONSORING/MONITORING AGENCY ACRONYM(S)</b> AFRL/PRTG	
				<b>11. SPONSORING/MONITORING AGENCY REPORT NUMBER(S)</b> AFRL-PR-WP-TP-2002-203	
<b>12. DISTRIBUTION/AVAILABILITY STATEMENT</b> Approved for public release; distribution is unlimited.					
<b>13. SUPPLEMENTARY NOTES</b> This report contains copyrighted material. Proceedings of TURBO EXPO 2002; ASME Turbo Expo: Land, Sea & Air 2002; June 3-6, 2002, Amsterdam, The Netherlands.					
<b>14. ABSTRACT (Maximum 200 Words)</b> Fuel-cooled thermal management, including endothermic cracking and reforming of hydrocarbon fuels, is an enabling technology for advanced aero engines and offers potential for cycle improvements and pollutant emissions control in gas-turbine engine applications. The successful implementation of this technology is, however, predicated on the use of conventional multi-component hydrocarbon fuels and an understanding of the combustion characteristics of the reformed fuel mixture. The objective of this research is to develop and demonstrate the technologies necessary for utilizing conventional multi-component hydrocarbon fuels for fuel-cooled thermal management, including the development of the endothermic potential of JP-7 and JP-8+100, a demonstration of the combustion of supercritical/endothermic fuel mixtures, and conceptual design of a fuel-air heat exchanger.					
<b>15. SUBJECT TERMS</b> endothermic fuels, thermal management, heat sink, fuel-air heat exchanger					
<b>16. SECURITY CLASSIFICATION OF:</b>			<b>17. LIMITATION OF ABSTRACT:</b> SAR	<b>18. NUMBER OF PAGES</b> 16	<b>19a. NAME OF RESPONSIBLE PERSON (Monitor)</b> Tim Edwards <b>19b. TELEPHONE NUMBER (Include Area Code)</b> (937) 255-3524
<b>a. REPORT</b> Unclassified	<b>b. ABSTRACT</b> Unclassified	<b>c. THIS PAGE</b> Unclassified			

Standard Form 298 (Rev. 8-98)  
Prescribed by ANSI Std. Z39-18

**GT-2002-30070**

## **FUEL-COOLED THERMAL MANAGEMENT FOR ADVANCED AERO ENGINES**

He Huang, Louis J. Spadaccini and David R. Sobel  
United Technologies Research Center  
East Hartford, CT 06108

### **ABSTRACT**

Fuel-cooled thermal management, including endothermic cracking and reforming of hydrocarbon fuels, is an enabling technology for advanced aero engines and offers potential for cycle improvements and pollutant emissions control in gas-turbine engine applications. The successful implementation of this technology is, however, predicated on the use of conventional multi-component hydrocarbon fuels and an understanding of the combustion characteristics of the reformed fuel mixture. The objective of this research is to develop and demonstrate the technologies necessary for utilizing conventional multi-component hydrocarbon fuels for fuel-cooled thermal management, including the development of the endothermic potential of JP-7 and JP-8+100, a demonstration of the combustion of supercritical/endothermic fuel mixtures, and conceptual design of a fuel-air heat exchanger. The ability to achieve high heat sinks with existing jet fuels (e.g., JP-7 and JP-8+100) was demonstrated with a bench-scale test rig operating under flow conditions and passage geometries simulative of practical heat exchangers for aircraft and missile applications. Key measurements included fuel heat sink, reaction products, and extent of conversion. Full-scale sector rig tests were conducted to characterize the combustion and emissions of supercritical jet fuel, and demonstrate the safety and operability of the fuel system, including a fuel-air heat exchanger.

### **INTRODUCTION**

Thermal management is a significant challenge in advanced aircraft, rocket, and missile engines. As flight speeds increase to the high supersonic and hypersonic regime, the temperature of the ram air taken on board the vehicle becomes too high to cool the structure and, therefore, it is necessary to utilize the fuel as the primary coolant. Although cryogenic fuels, such as liquid methane and liquid hydrogen, can provide sufficient cooling, they require large vehicles (because of their low densities) and present cost, logistics, operational and safety

problems. By contrast, conventional liquid hydrocarbon fuels may offer the required cooling capacity without the problems associated with cryogenic fuels. For example, paraffinic liquid hydrocarbon fuels have significant sensible heat sink capacities for supersonic aircraft applications and may undergo endothermic chemical cracking on a catalyst for hypersonic missile applications [1].

Advanced gas turbine engines are more efficient and burn less fuel per pound of thrust, reducing the amount of cooling capacity available during operation; larger and more powerful avionics systems require significant cooling; and wings are now constructed largely of composite materials (instead of aluminum) that do not reject heat well to the atmosphere. Also, structural cooling may be incorporated to reduce the aircraft infrared (IR) signature, significantly increasing vehicle heat loads. Future aircraft are projected to operate at high Mach numbers, where aerodynamic heating becomes a design driver, and to be powered by engines that operate at high pressures and fuel/air ratios, thereby greatly increasing heat loads and exacerbating the thermal management task.

Vehicle waste heat can be rejected to either fuel or air. Taking advantage of the air heat sink involves relatively heavy heat exchangers and a vehicle drag penalty, while adding waste heat to the fuel can be done with a more compact and structurally integrated heat exchanger and actually benefits the engine thermodynamic cycle by reducing the engine specific fuel consumption. Furthermore, increasing aircraft speed and engine thrust-to-weight ratio results in large simultaneous increases in heat load and temperature of the air available for cooling, thereby shifting the burden for engine and vehicle cooling to the fuel.

The total heat sink of a hydrocarbon fuel comes from the physical heating of the fuel (raising its temperature and thereby its sensible enthalpy) and a heat-absorbing (endothermic) chemical reaction. Nixon and his co-workers [2,3] first demonstrated that the selective dehydrogenation of

methylcyclohexane (MCH) on a platinum/alumina catalyst can provide a total heat sink of nearly 900 Btu/lb. MCH, the first-generation endothermic fuel, offers sufficient heat sink for cooling a Mach 4 to 6 aircraft, but is much more expensive than current aviation fuels and requires a very expensive platinum catalyst. On a practical path to realize the hydrocarbon fuel cooling technologies, Sobel and Spadaccini [1] first investigated the endothermic potential of liquid hydrocarbon fuels with inexpensive and readily available catalysts under operating conditions simulative of high-speed flight applications. High heat sink capacities and desirable reaction products were demonstrated in their study for pure paraffin (e.g., n-heptane) and blended normal paraffin (e.g., Norpar 12) fuels in coated-tube reactor configurations.

The current research is directed at developing the endothermic potential of JP-7 and JP-8 (including JP-8+100 and Jet A), i.e., conventional kerosene-base gas-turbine fuels, using an inexpensive and readily available catalyst. Given the potential benefits of a fuel-cooled thermal management system, there are also many new technology issues that must be addressed. Structural integrity and safety of all components are considered to be paramount concerns. Operability issues in the supercritical regime and the capability to handle engine transients also pose serious challenges throughout the fuel system, including heat exchangers, control valves and fuel injectors. Two-phase (i.e., liquid/vapor) fuel injection over a range of flight conditions presents combustor development challenges for efficiency, exhaust pattern factor, and emissions. In addition, combustion instability issues associated with the introduction of a compressible fuel must be addressed. Consequently, it is also an objective to develop and demonstrate technology required for applying fuel cooling in thermal management systems for advanced gas turbines. The approach adopted in this study involves full-scale sector rig tests to 1) characterize the combustion and emissions of supercritical/reformed jet fuel, 2) demonstrate the safety and operability of the fuel system, and 3) evaluate the required component designs, such as a supercritical-fuel combustor with liquid/vapor fuel injectors, and fuel-air heat exchangers.

## SYSTEM DESIGN CONCEPTS

Supercritical/endothermic fuel cooling technology can be implemented in a practical aircraft thermal management system in two different ways: direct cooling, which refers to the incorporation of the heat exchanger into the structure of a hot component, such as a scramjet combustor, an augmentor, or a turbine exit guide vane; and indirect cooling, wherein ram air or compressor bleed air is cooled by the fuel in a nearby heat exchanger, and then used to cool the hot components. This indirect cooling, "cooled cooling air", allows a substantial increase in engine pressure ratio, with corresponding improvement in the thrust-to-weight ratio [4,5], and thermal efficiency. In both ways, the cooling capacity of conventional hydrocarbon fuels is limited by a temperature constraint

necessary to preclude coke deposition [6,7]. For example, the cooling capacity of JP-8 or Jet A is limited to temperatures of approximately 325 F due to autoxidative coke deposition. Additives incorporated into JP-8+100 to suppress the autoxidative coke deposition permit extension of this limit to approximately 425 F [8]. Higher fuel temperatures, and thereby higher sensible heat sinks, can be achieved through implementation of coke-mitigation strategies (e.g., operation at supercritical pressures, coke-tolerant designs, surface treatments, surface regeneration) [6,9]. Since the primary factor contributing to autoxidative coke deposition at temperatures up to approximately 700 F is oxygen dissolved in hydrocarbon fuels, techniques to remove that oxygen are particularly attractive. Spadaccini and Huang [10] first demonstrated the feasibility of an on-line deoxygenation concept for improving the fuel thermal-oxidative stability and thereby increasing the cooling capacity. The study established potential for realizing the thermal stability goals for JP-8+225/JP-900 [11] using a membrane-based deoxygenation technique. At temperatures above approximately 900 F, the sensible heat sink can be supplemented by a heat absorbing chemical reaction as the fuel undergoes thermal and catalytic cracking reactions that reform it into a mixture of lighter hydrocarbons and hydrogen [1], which is then burned in the engine. The coke deposition mechanism in this high temperature regime is characterized by pyrolysis. In this process, the catalyst can serve to enhance the endothermic reaction rate, improve the selectivity of the reaction for the preferred products that may have shorter ignition delay times and more rapid burning rates, and reduce the coke formation. The starting temperatures for the endothermic reactions depend primarily on the catalyst and the fuel composition. They are also a function of fuel flow rate and residence time.

In a hypersonic missile application where endothermic reactions are required, the transfer of heat into the fuel is accomplished in a catalytic fuel-air heat exchanger reactor (CHER). Within a reactor flow passage, the rate at which fuel is reformed depends on the balance among the heat transfer through the wall, the mass transfer of fresh reactant to the catalyst, and the chemical kinetics associated with both the thermal and catalytic reactions. Therefore, the reactor design requires 1) excellent structural integrity for safely implementing high temperature air-fuel heat exchanger operation, 2) high convective heat transfer coefficients for rapid transfer of heat from air into the fuel, 3) minimum thermal resistance through the use of high conductivity materials and very thin (micron thickness) catalyst coatings bonded to the reactor walls, 4) high fuel-side mass transfer coefficient to enhance catalytic cracking reactions, and 5) lightweight and low cost.

## Performance Characterization of Fuels

**Compositions and Properties of Fuels.** JP-7 and JP-8 (the more conventional gas-turbine fuel) were chosen as the primary

fuels in this study. These multi-component hydrocarbon fuels are defined by their physical properties and broad composition guidelines (e.g., aromatics limits) rather than specific chemical compositions. Many of the defining characteristics can be found in the CRC Handbook for aviation fuels [12]. JP-7 is a military jet fuel with high thermal stability. The fuel specifications for JP-7 require that aromatics comprise less than 5 percent of the fuel (as determined by ASTM D-1319), the remainder of the composition being saturated species, i.e., normal-, iso-, and cyclo-paraffins. JP-8, including Jet A, Jet A-1, and JP-8+100, represents a class of kerosene fuels. Of these gas-turbine fuels, JP-8+100 was the focus of the current effort; however, its similarity and relationship to the other fuels in this class warrant explanation. Jet A serves as the baseline commercial gas-turbine fuel within the United States. Jet A-1, which differs from Jet A by having a prescribed freezing point of -53 F, instead of the -40 F associated with Jet A, is the primary commercial gas-turbine fuel outside the United States. JP-8 is the primary military gas-turbine fuel and is essentially Jet A-1 with an additive package including icing and corrosion inhibitors and an anti-static component. A supplementary additive package was developed by the Air Force to extend the thermal stability limit of JP-8 (~325 F) by 100 F. The additive package includes a dispersant, an antioxidant and a metal deactivator, and the resulting fuel is designated JP-8+100. Based on composition analyses of the jet fuels in this study and results reported by Heneghan et al. [13], 6-component and 11-component models, as listed in Table 1, were developed to simulate analytically the much more complex JP-7 and JP-8, respectively. These fuel simulations allow computations of the physical and thermodynamic properties of the jet fuels using the NIST SUPERTRAPP program [14].

**Test Apparatus and Analysis Procedures.** The high-pressure bench-scale test apparatus is shown schematically in Figure 1. Fuel is metered into the system at supercritical pressure using a positive-displacement pump. Fuel preheating to approximately 700 F (supercritical) was utilized for all tests involving endothermic reactions in order to reduce the reactor length requirement. Resistive heating was used to allow a direct measurement of the overall heat sink capacity of the fuels by

performing an energy balance on the control volume depicted in Figure 1. With this method, heat is supplied by the imposition of an electric current through the reactor tube itself. The electrical power input,  $Q_{in}$ , is converted to heat and transferred to the fuel on the inside of the reactor and, by natural convection, to the environment on the outside. The portion of heat lost to the environment through natural convection,  $Q_{env}$ , is minimized by insulation and accounted for through multi-point calibrations without fuel flow prior to given tests. (The heat losses were in the range of 3 to 8% of the total power input, depending on the reactor wall temperatures and fuel flowrate.) The overall heat sink of the fuels,  $Q_{sink}$ , can be computed by

$$Q_{sink} = Q_{in} - Q_{env} \quad (1)$$

Thermodynamically, the cooling capacity is defined as an enthalpy change of fuel between the inlet and exit. It can be calculated by

$$H_{exit} - H_{inlet} = \frac{Q_{sink}}{\dot{m}} \quad (2)$$

where  $H_{inlet}$  and  $H_{exit}$  are the fuel enthalpies at the reactor inlet and exit, respectively, and  $\dot{m}$  the fuel mass flowrate. The overall heat sink of fuel ( $Q_{sink}$ ) can be further divided into that which results in raising the temperature of the fuel/products (sensible heating,  $\Delta H_{sens}$ ) and that which is absorbed in the reaction (endotherm,  $\Delta H_{endo}$ ). The net endotherm can then be computed as

$$\Delta H_{endo} = (H_{exit} - H_{inlet}) - \Delta H_{sens} \quad (3)$$

and sensible heat sink computed as a function of the fuel temperatures measured at the reactor inlet ( $T_{inlet}$ ) and exit ( $T_{exit}$ ) by

$$\Delta H_{sens} = H(T_{exit}) - H(T_{inlet}) \quad (4)$$

For the purpose of sensible enthalpy calculation, the fuel composition remains constant.

All reactors were coated with an inexpensive zeolite cracking catalyst using a ceramic-like binder. In addition to the fuel temperature measurements at the reactor inlet and exit, the fuel pressures were also measured at the reactor inlet and exit to correlate reactor performance. A differential pressure gauge was used to measure and track-in-time the reactor pressure

Table 1: Jet Fuel Simulations

Component	Molar Fraction	Component	Molar Fraction
<b>JP-7</b>			
n-undecane	0.122	n-tetradecane	0.031
n-dodecane	0.289	n-pentadecane	0.018
n-tridecane	0.368	ethylcyclohexane	0.172
<b>JP-8</b>			
methylcyclohexane	0.075	t-butylbenzene	0.055
meta-xylene	0.070	n-dodecane	0.175
n-octane	0.130	1-methylnaphthalene	0.052
n-decane	0.156	n-tetradecane	0.112
butylbenzene	0.055	n-hexadecane	0.065
isobutylbenzene	0.055		

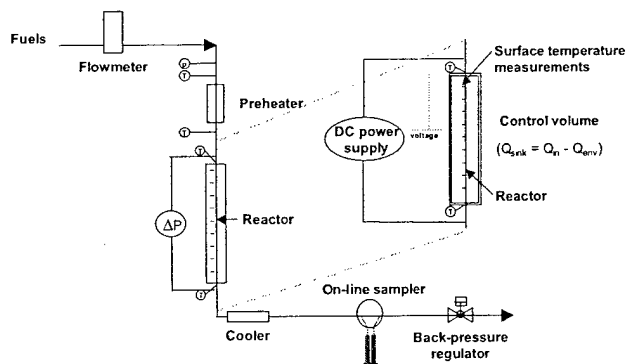

Figure 1: Bench-Scale Reactor Test Rig

drop, which is indicative of coke deposition. Since the coated-wall reactor tubes were generally small diameter (<0.10 in.) to simulate practical heat exchanger reactor passages, only tube outer wall temperatures were measured along the reactor. Downstream of the reactor, the products were quenched in a water-cooled heat exchanger and the liquid and gaseous products were collected in an on-line biphasic sample collector for compositional analysis. The liquid and gaseous components were separated and analyzed using both a cryocooled Hewlett Packard Gas Chromatograph/Mass Spectrometer (GC/MS) system and a fast-response MTI Micro Gas Chromatograph. The extent of conversion of the fuel to gaseous products was determined by measuring the weight change after collecting the gaseous products in an atmospheric pressure sample bag at ambient temperature.

**Heat Sinks of Fuels.** The results of the heat sink tests of a baseline fuel, n-octane, and primary fuels, JP-7 and JP-8+100 are shown in Figures 2-4. The detailed testing conditions are described in Table 2. As mentioned above, the wall temperatures were measured along the reactor and the data showed similar wall temperature distributions for different fuels. The peak wall temperatures were located about 1 to 2 inches from the exit, and found to be 100 to 150 F higher than exit fuel temperatures, depending primarily on fuel flow rates. All the tests were run to the maximum operating temperatures, defined by the point where the reactors were plugged by coke deposition. The total heat sinks (i.e., physical + chemical) and estimated endotherms (chemical only) for n-octane, JP-7, and JP-8+100 are also depicted in Figures 2 to 4. The physical heat sinks (sensible enthalpy differences) of the hydrocarbon fuels

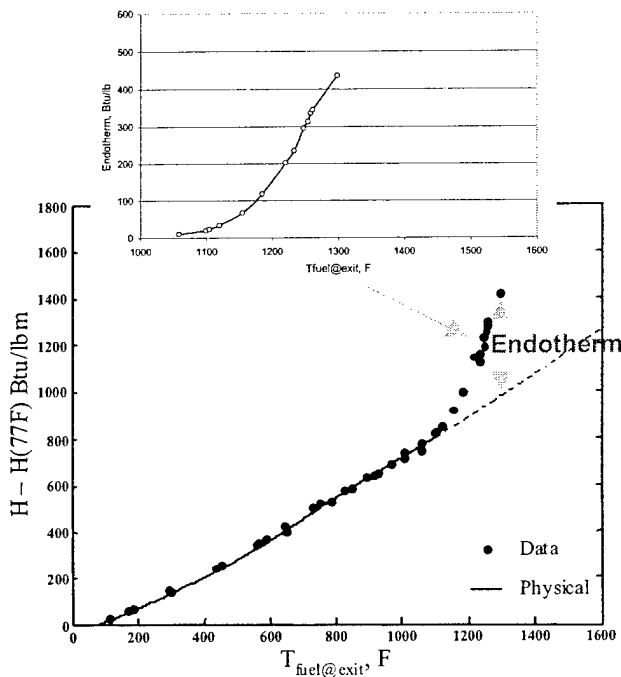

Figure 2: Heat Sink of n-Octane

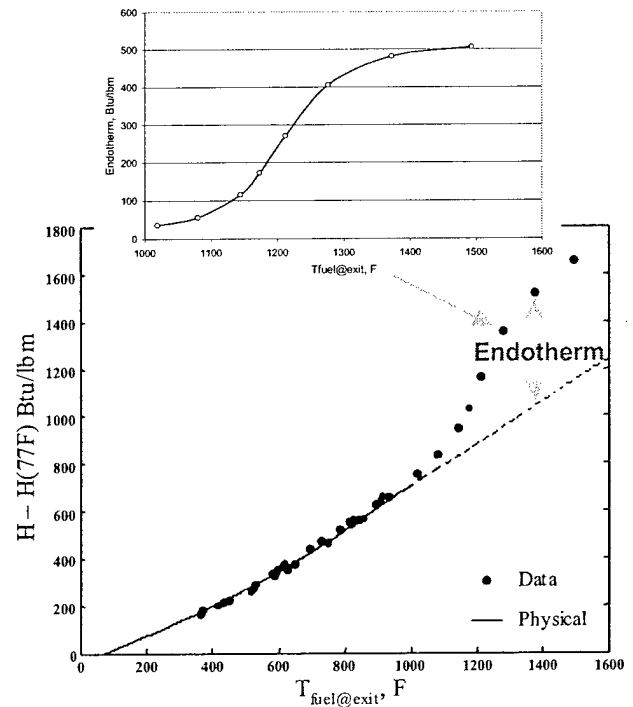

Figure 3: Heat Sink of JP-7

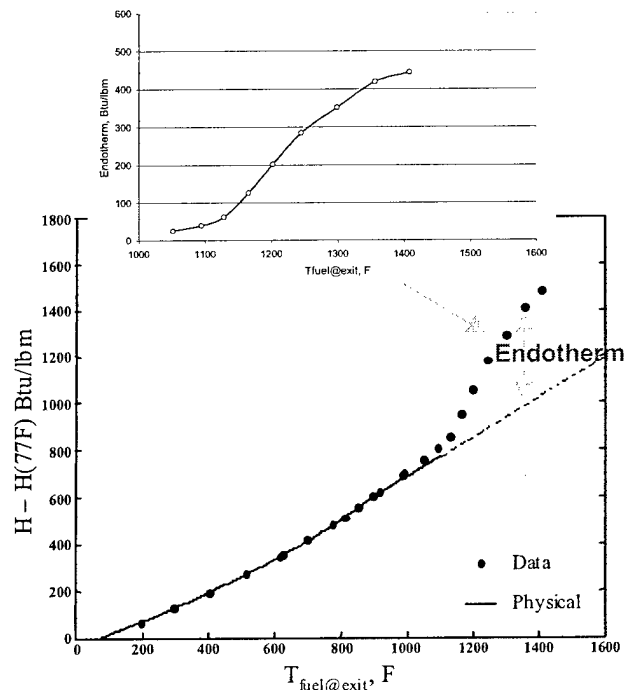

Figure 4: Heat Sink of JP-8+100

at the high temperatures (i.e., > ~1000 F) where chemical reactions occur are estimated using the NIST computer program SUPERTRAPP. The SUPERTRAPP computations

Table 2: Testing Conditions

Parameter	Condition
Tube size	1/8" OD; 0.035" wall thickness; 24" length
Catalyst coating	P-octocat
Pressure	600 psia
Mass flowrate	4.8 lbm/hr
LHSV	3000 1/hr
Fuel	JP-7, JP-8+100, and n-octane

were carried out based on the temperature measurements at the reactor inlet and exit, and the fuel simulations in Table 1. Comparison of the total heat sinks (on a mass basis) among these fuels at the flow conditions tested indicates that:

- There are insignificant differences in physical heat sink among these fuels;
- n-Octane and JP-7 have similar endotherms under the same temperatures. However, JP-7 has the lowest coke formation rate, probably due to its low olefin, low aromatics, low sulfur, and/or high cyclo-paraffin contents. Therefore, JP-7 can operate at higher temperature and provides higher heat sink; and
- JP-8+100 has slightly lower endotherm than those of n-octane and JP-7 under the same temperatures due to its higher aromatics content. Aromatics are not cracked (thermally or catalytically) under the conditions tested.

The chemical heat sink (endotherm) is a function of not only conversion but also product distribution. The change in JP-8+100 gaseous product composition with increasing temperature is shown in Figure 5 and indicates a trend toward lower molecular weight species. Chromatographs of two JP-8+100 liquid product samples taken at temperatures of approximately 1100 and 1300 F indicate that the 1100 F sample was similar to that of unreacted JP-8+100, while at the higher temperature, nearly full conversion of paraffinic species and extensive side-chain cracking of aromatics to benzene and toluene were observed. To provide a more detailed analysis, liquid samples, corresponding to the gas samples in Figure 5, were sent to a commercial laboratory. The analysis identified more than 400 separate peaks with no single peak accounting for more than approximately 5-percent of the liquid by weight. The analysis, however, provided a distribution of the products both by carbon number and class, shown in Figure 6. A comparison between the unreacted and reacted JP-8+100 liquid products indicates a substantial shift in the composition to lower molecular weight species, with the shift becoming more pronounced at higher reaction temperature. The analyses also indicated that no species with molecular weights higher than those of the unreacted fuel components were being formed as a result of the reaction (species up to C<sub>100</sub> would have been detected with the analytical techniques used). Furthermore, the total amount of aromatics was unchanged through the reactor, indicating that the temperatures were not high enough to break the aromatic ring, nor were aromatics being created from non-aromatic compounds. It should be noted, however, that the

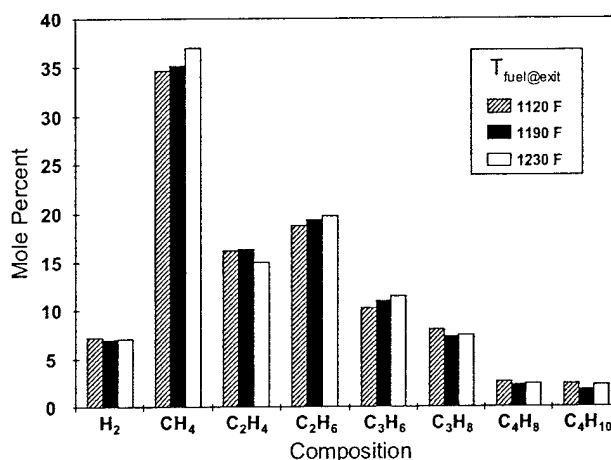

Figure 5: JP-8+100 Gaseous Product Composition

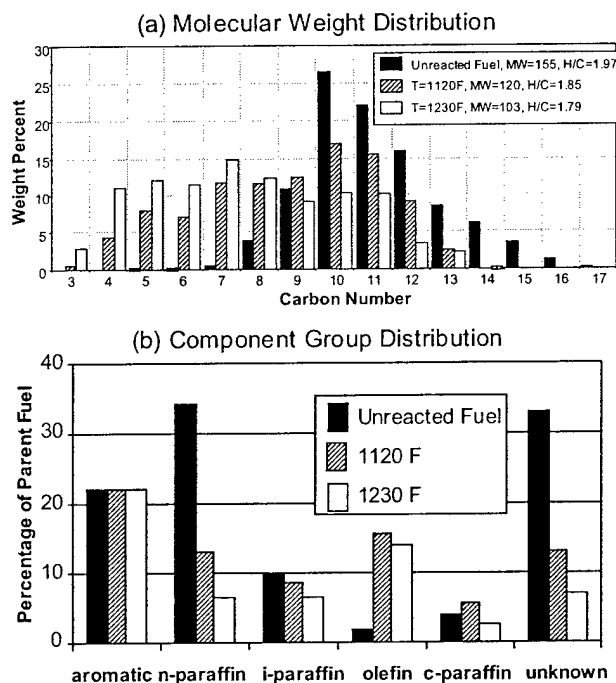

Figure 6: JP-8+100 Liquid Products

amounts of simple aromatics (benzene and toluene) are increased, reflecting the stripping of side chains from alkylated aromatics. As expected for endothermic reactions, the analyses also proved high effectiveness in cracking normal paraffins and forming olefinic compounds in the liquid products.

There is an expected trend toward greater conversion to hydrogen and methane with increasing temperature for the JP-7 gaseous products. Although the primary species of gaseous products obtained are the same with JP-7 and JP-8+100, the JP-7 products have a significantly lower methane concentration. In

addition, compared to JP-8+100, JP-7 demonstrates higher conversion and endotherm at a given temperature, because of its low aromatics content. Also, as was the case with the JP-8+100 liquid products, the chromatographs of unreacted and reacted (e.g., 1200 F) JP-7 indicate substantial reforming of the fuels in the liquid-product mixture.

To investigate possible differences in reaction performance, tests were run with Jet A and JP-8 allowing direct comparison with the tests of JP-8+100. The endotherms achieved with the various fuels are very similar, indicating no significant effect attributable to the fuel additives. The effect of flow rate, in terms of Liquid Hourly Space Velocity (LHSV), was also investigated for JP-8+100 in the range of 500 - 3000 hr<sup>-1</sup>. (LHSV is defined as the volumetric flow rate of the fuel in its liquid state divided by the volume of the reactor.) For a given reactor geometry, increasing the space velocity by a factor of two to six results in an increase in Reynolds number and decrease in residence time by essentially the same factor. The results indicate a lower conversion and correspondingly lower endotherm at the higher space velocity under these operating conditions.

### COMBUSTION TESTS

A high-temperature, moderate-pressure, vitiated-air combustion test facility, shown schematically in Figure 7, was used for developing technology required for demonstrating a high-heat-sink-fuel thermal management and combustion system. The apparatus consists of an Air Preparation Section and separate airflow paths for a Three-Nozzle, Arc-Sector Combustor Test Section and a Catalytic Heat Exchanger Reactor (CHER) Test Section. An electrically heated catalytic-tube reactor was used for preheating the fuel or supplying supercritical fuel for combustion tests conducted without a CHER.

Vitiated air heated to approximately 1200 F and 100 psia was used to simulate combustor-inlet/turbine-cooling air. The vitiated-air heater was designed (and has been demonstrated) to generate low nitric oxides emissions (emission index < 1) at all operating conditions. It was supplied with non-vitiated air preheated to 800 F, and fired with natural gas. Gaseous oxygen was added downstream to restore the oxygen concentration to the atmospheric level of 21 mole percent.

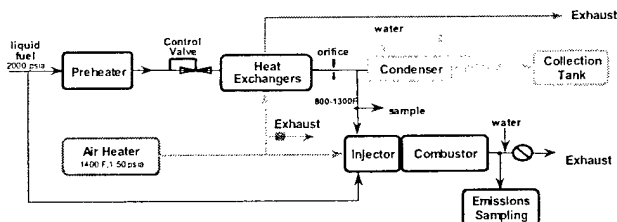

Figure 7: Schematic of Fuel-Air Heat Exchanger/Combustor Test Facility

The liquid JP-8+100 fuel was preheated (as required) prior to entering the heat exchanger, where the temperature was increased to 800-1300 F (supercritical). Fuel pressure was maintained above critical in the CHERs (i.e., > 340 psia) to preclude condensation and mixed-phase flow, and the flow rate was regulated using a high-temperature control valve and calibrated orifices.

The combustor assembly, shown in Figure 8, comprised a 45-deg section of the pre-diffuser and combustor of a high-performance military engine. The prototype high-shear liquid/vapor fuel injection nozzle, shown in Figure 9, contains three separate flow circuits for liquid and supercritical vapor fuel injection. Liquid fuel is injected through a single primary orifice in the center of the nozzle, and six secondary orifices in the inner annulus. Vapor fuel is injected through twelve orifices in the outer annulus. Air for atomizing and distributing the fuel is introduced around the nozzle through a large tailor-vortex, radial-inflow swirler. The flow through each of the fuel circuits was metered continuously. The liquid fuel passages were thermally isolated from the hot fuel vapor and surrounding air stream to avoid coke formation. JP-8+100 fuel was used for all tests, and performance measurements were acquired for operation with all liquid fuel, and with liquid fuel and different percentages of vapor fuel. The composition of the combustor exhaust gases was determined by extracting gas samples at the exit plane of the combustor with a sampling-

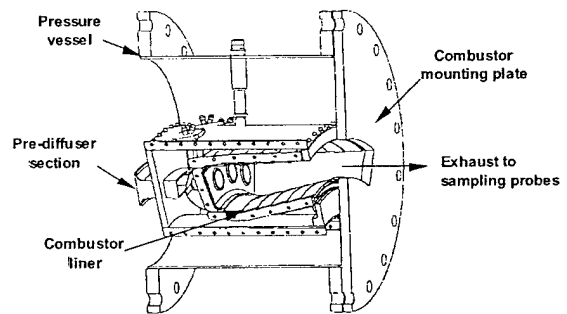

Figure 8: Combustor

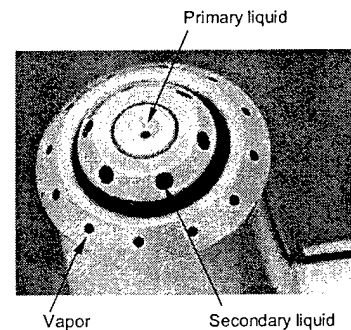

Figure 9: Liquid/Vapor Fuel Nozzle

probe rake assembly. Five exhaust gas sampling rakes, with five probes each, were located directly downstream of the combustor. Measurements were made of the emissions of carbon monoxide, carbon dioxide, oxygen, nitric oxides, total unburned hydrocarbons, and smoke.

Combustion tests were performed with all liquid fuel and with different percentages of supercritical vapor fuel. A base-power inlet condition of 100 psia and 1200 F was selected, and tests were conducted at progressively higher fuel/air ratios and with higher percentages of vaporized fuel injection. In these tests, the fuel was preheated electrically to approximately 700 F and then heated in the fuel-air heat exchanger to a supercritical injection temperature of approximately 900 F. Tests were conducted at  $f/a = 0.035$  to  $0.055$  (equivalence ratio 0.5 to 0.8) with 100 percent liquid fuel, and with 30, 38, and 52 percent vapor fuel injection. The results, shown in Figure 10, present the combustion efficiency and smoke number as functions of the fuel/air ratios (calculated from the measured air and fuel flow rates).

The data demonstrate the ability to achieve efficient combustion (>99%) and good operability with a significant fraction (52%) of the fuel injected in the supercritical vapor state. The results also indicate that, as the fuel/air ratio is increased, the combustion efficiency decreases while the smoke and carbon monoxide emissions increased significantly and nitric oxides emissions remained nearly constant, suggesting

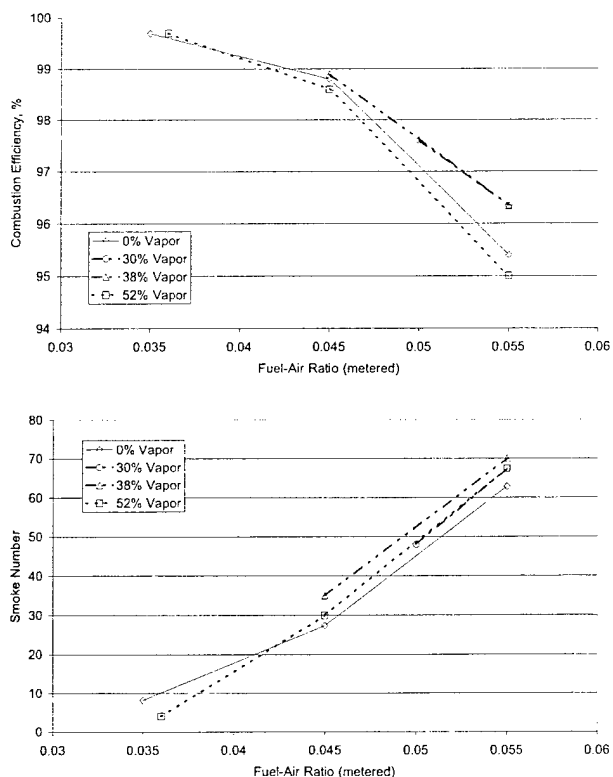

Figure 10: Effect of Vapor Fuel on Combustor Performance

that there is seemingly little effect on the peak combustion temperature. For the most part, the performance of the combustor was essentially unchanged by injecting a portion of the fuel as a supercritical vapor. Although there are some differences, they are small and the trends inconsistent, suggesting that there may be scatter in the data. The goal of efficient combustion with vaporized fuel was achieved without a significant increase in emissions, and the viability of the concept demonstrated. Although injection of low-density vapor fuel should enhance mixing, and thereby lower smoke emissions, the fuel must be effectively dispersed throughout the primary combustion zone in order to realize the benefit. In the present program, vapor fuel injection was not advanced to the extent possible, and would benefit from further development.

Injection of a compressible vapor fuel into a combustor will increase the potential for acoustic instability due to a coupling of the resonant frequencies of the chamber and the fuel delivery system. Furthermore, the enhanced mixing and accelerated heat release anticipated from the use of supercritical/reformed fuel could either intensify or diminish this problem, depending upon the magnitude of the energy buildup prior to ignition.

The sensitivity of the combustor to potential acoustic instabilities was determined from pressure measurements in the injector and in the burner inlet cowl. High-frequency-response transducers were used to measure pressures in the liquid and vapor fuel manifolds, and to monitor the pressure in the combustor inlet cowl. To improve the combustor simulation and isolate measurements from rig-generated pressure disturbances in the exhaust ducting, water-cooled tubes were installed between each of the sampling probe rakes to increase the blockage and choke the flow, simulating the turbine guide vane of the engine.

Power spectral density plots for operation at the base-power inlet condition with fuel/air ratio 0.026 are given in Figure 11. The zero-to-peak pressure fluctuation is plotted versus frequency. The effects of supercritical vapor injection on acoustic instability are determined by comparing the pressure response with and without vapor injection. The results indicate that the system operates essentially the same, with or without vapor injection, and that no new acoustic instabilities were introduced. The fuel manifold pressure measurements (i.e., primary, secondary and vapor) indicate the same dominant frequencies of approximately 300 to 400 Hz, and pressure oscillations of approximately  $\pm 0.2\%$ .

## FUEL-AIR HEAT EXCHANGER DESIGN

Conceptual design studies have examined a wide range of potential fuel-air heat exchanger concepts for fuel-cooled thermal management system (e.g., cooled cooling air) and identified one design concept as an array of compact plate-fin heat exchangers constructed from high-temperature/strength super alloys for the combustion tests described above. The design consists of a multi-layer plate-fin heat exchanger array, with the fuel and air flowing in a crossflow arrangement (see

Figure 12). A monolithic fuel passage construction was selected to satisfy safety and structural concerns. The design differs from conventional heat exchanger practice in that the fuel passages are formed by the chemical milling of semi-

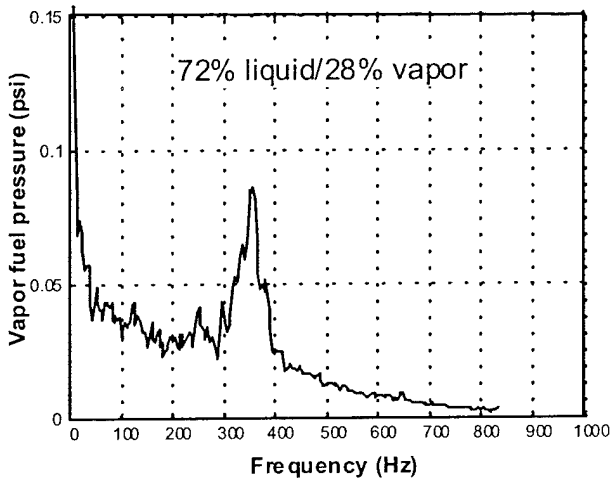
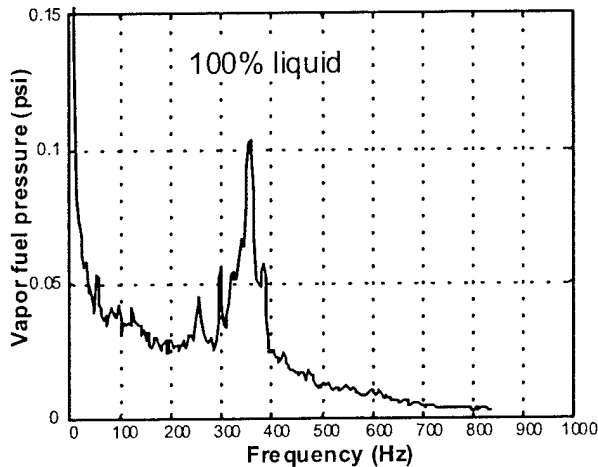

Figure 11: Effect of Vapor Injection on Combustor Acoustics

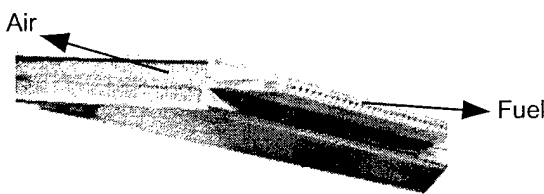

Figure 12: Fuel-Air Plate-Fin Heat Exchanger

circular channels in solid facing plates, which are subsequently diffusion bonded into an integral structure. Corrugated fins and cover sheets are then brazed to the fuel plate to provide air passages. Although such a design concept was validated in the combustion tests reported above, it was heavy and expensive.

New technologies are needed in the development of lightweight, low cost, high temperature, and geometry-flexible fuel-air heat exchangers for fuel-cooled thermal management systems. One of the most promising designs to satisfy these requirements is to use advanced metal foam structures. The foams have low density and high specific surface areas, enabling lightweight and high heat transfer, respectively. Furthermore, the three-dimensionality of the open-cell foam structure minimizes the possibility for non-uniform flow in the airside. The foam can be bonded to metal tubes (fuel passages) forming an integral heat exchanger core that satisfies the structural and safety requirements (see Figure 13).

Type 316 stainless steel was selected for making prototype metal foams and foam/tube elements because of its strength at the high temperatures required for advanced gas turbines. It will serve as a starting material for the manufacturing process development. Nickel was also selected for evaluation owing to its high thermal conductivity and moderate temperature capability. Several monolithic and bonded stainless steel and nickel foam-tube heat exchanger modules, shown typically in Figure 13, have been fabricated and tested. In the sample shown in the figure, the bonding of tubes to the foam and the final sintering of foams were incorporated into one processing step, offering the potential for low cost fabrication. These modules have been assembled into a fuel-air heat exchanger performance characterization rig for assessing the effective thermal conductivity, pressure drop and heat transfer characteristics.

A CFD model was developed for assessing the conceptual design of a metal-foam fuel-air heat exchanger for a range of engine operating conditions. To optimize the overall performance, defined as a ratio of the temperature drop to the pressure drop in the airside, a cross-flow design, shown in Figure 14, was developed in which the air and fuel make two passes through the metal-foam; the fuel tubes are U-shaped. The bleed air first flows upward through the foam and across a bank of tubes containing the inlet fuel flow, and then is turned

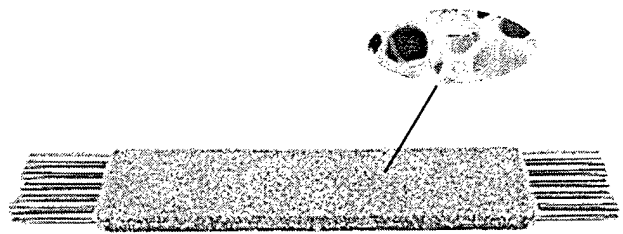

Figure 13: Stainless Steel Foam-Tube Module

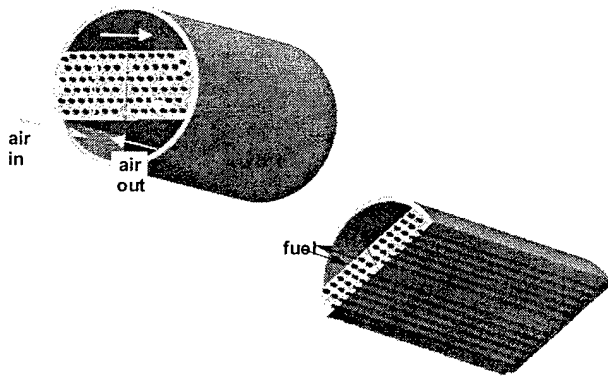

Figure 14: Conceptual Design of Fuel-Air Metal Foam Heat Exchanger

180° and flows across a second bank of tubes through which the heated fuel exits. A full-size heat exchanger component based on this design will be fabricated and incorporated into a thermal management system of a demonstrator rig or engine. The test conditions and procedures will be specified, and a series of tests will be conducted to satisfy requirements for integrating the metal foam heat exchanger into an engine thermal management system.

## CONCLUSION

Key technologies necessary for utilizing the supercritical/endermotic heat sink capacity of current aircraft fuels in a fuel-cooled thermal management system were developed and demonstrated in this study. The endothermic heat sink capacities of the conventional hydrocarbon fuels (viz., JP-8+100 and JP-7) were demonstrated under operating conditions simulative of practical applications. Performance evaluations were primarily based on overall heat sink (including endotherm) measurements and coke deposition. For the fuels studied, compositional analyses of both the parent fuel and processed fuel were performed and possible endothermic reforming/cracking reaction mechanisms identified. The results are directly applicable to the selection of fuels and the design of fuel-cooled thermal management systems for advanced aircraft engines and missile applications. The operability and performance characteristics of a supercritical-fuel combustor with liquid/vapor fuel injectors were demonstrated, and conceptual designs of fuel-air heat exchangers were developed for cooling compressor bleed air for turbine cooling.

Combustion tests were conducted on a full-scale sector rig to characterize the combustion and emissions of supercritical/endermotic jet fuel, and the safety and operability of the fuel system. Combustion efficiency greater than 95 percent was achieved over a range of part- to full-power conditions, with up to 55 percent of the fuel flow prevaporized in the heat exchanger. The combustor stability, efficiency, emissions and pattern factor were found to be as good as the combustor operating on all-liquid fuel.

Based on the results of the current research, the following specific conclusions may be made:

- The cooled cooling air concept is feasible and can be implemented using conventional kerosene-base fuels as the heat sink.
- Substantial endotherms are achievable with JP-7 and JP-8+100 fuels using inexpensive zeolite catalysts in practical-geometry passages. With JP-8+100, endotherms of approximately 370-440 Btu/lbm were achieved at LHSV's of 3000 hr<sup>-1</sup> and fuel exit temperatures above 1300 F, corresponding to an overall available heat sink of approximately 1290-1480 Btu/lbm. JP-7, because of its low aromatics content, realized an endotherm of 420-500 Btu/lbm at similar temperatures and LHSV's, corresponding to an overall heat sink of 1420-1650 Btu/lbm. These heat sinks are very attractive for both gas turbine and hypersonic missile applications.
- There are insignificant differences in physical heat sink among the liquid hydrocarbon fuels, namely n-octane, JP-7 and JP-8+100.
- The combustor performed as well with new liquid/vapor fuel injectors as with the current all-liquid fuel injectors. A desired reduction in smoke emissions was not achieved; however, the injector system was not developed to the maximum extent and appears to show room for further improvement.
- The effects of fuel vapor injection and vapor temperature on the acoustic response of the combustor are very small.

## ACKNOWLEDGMENT

This paper is based on research supported by the United Technologies Corporation, and work performed for the Air Force Research Laboratory, Propulsion Directorate under Contracts F33615-92-C-2295 and F33615-97-D-2784, administered by Dr. Tim Edwards of the Fuels Branch, Turbine Engine Division, and Office of Naval Research under Contract N00014-00-2-0002, administered by Dr. Steven Fishman. The authors gratefully acknowledge the test support provided by Dr. Donald Hautman, Mr. David McHugh, Mr. Jay Borst, and Mr. John Hawkins.

## REFERENCES

- [1] Sobel, D. R. and Spadaccini, L. J., 1997, "Hydrocarbon Fuel Cooling Technologies for Advanced Propulsion," ASME J. Eng. Gas Turbines Power, **119**, pp. 344-351.
- [2] Nixon, A. C., Ackerman, G. H., Hawthorne, R. D., Ritchie, A. W., Henderson, H. T., and Bjorklund, I. S., 1964, "Vaporization and Endothermic Fuels for Advanced Engine Applications," AFAPL TDR 64-100, Parts I, II, and III.
- [3] Nixon, A. C., Ackerman, Faith, L. E., Hawthorne, R. D., A. W., Henderson, H. T., Rithie, A. W., Ryland, L. B., and Shryne, T. M., 1967, "Vaporization and Endothermic Fuels for Advanced Engine Applications," AFAPL TDR 67-114, Parts I, II, and III.

- [4] Bruening, G. B. and Chang, W. S., 1999, "Cooled Cooling Air Systems for Turbine Thermal Management," ASME Paper No. 99-GT-14.
- [5] Glickstein, M. R. and Spadaccini, L. J., 1998 "Applications of Endothermic Reaction Technology to the High Speed Civil Transport," NASA Contractor Report 207404.
- [6] Spadaccini, L. J., Sobel, D. R., and Huang, H., 2001, "Deposit Formation and Mitigation in Aircraft Fuels," ASME J. Eng. Gas Turbines Power, **123**(4), pp. 741-746.
- [7] Hazlett, R. N., 1991, *Thermal Oxidation Stability of Aviation Turbine Fuels*, ASTM Monograph 1, American Society for Testing and Materials, Philadelphia, PA.
- [8] Heneghan, S. P., Zabarnick, S., Ballal, D. R., and Harrison, W. E., 1996, "JP-8+100: Development of a Thermally Stable Jet Fuel," ASME J. Energy Resources Technology, 118, pp. 170-179.
- [9] Huang, H. and Spadaccini, L. J., 2001, "Coke Removal in Fuel-Cooled Thermal Management Systems," ASME Paper No. 2001-GT-0073.
- [10] Spadaccini, L. J. and Huang, H., 2002, "On-line Fuel Deoxygenation for Coke Suppression," ASME Paper No. GT-2002-30071.
- [11] Edwards, T., 1998, "Prospects for JP-8+225, A Stepping Stone to JP-900," AIAA Paper 98-3532.
- [12] Coordinating Research Council-SAE, 1983, Handbook of Aviation Fuels, CRC Report 530.
- [13] Heneghan, S. P., Locklear, S. L., Geiger, D. L., Anderson, S. D., and Schultz, W. D., 1993, "Static Tests of Jet Fuel Thermal and Oxidative Stability," AIAA J. of Propulsion and Power, **9**, No. 1, pp.5-9.
- [14] Ely, J. F. and Huber, M. L., 1998, NIST Standard Reference Database 4 – NIST Thermo-physical Properties of Hydrocarbon Mixtures.