

# Anthrax and Smallpox: Comparison of Two Outbreaks

Jeanne Guillemin

Senior Fellow

MIT Security Studies Program

## Report Documentation Page

<b>Report Date</b> 03APR2002	<b>Report Type</b> N/A	<b>Dates Covered (from... to)</b> 03APR2002 - 04APR2002
<b>Title and Subtitle</b> Anthrax and Smallpox: Comparison of Two Outbreaks	<b>Contract Number</b> F19628-00-C-0002	
	<b>Grant Number</b>	
	<b>Program Element Number</b>	
<b>Author(s)</b> Guillemin, Jeanne	<b>Project Number</b>	
	<b>Task Number</b>	
	<b>Work Unit Number</b>	
<b>Performing Organization Name(s) and Address(es)</b> MIT Security Studies Program	<b>Performing Organization Report Number</b>	
<b>Sponsoring/Monitoring Agency Name(s) and Address(es)</b> Air Force ESC/XPK (Richard Axtell) Hanscom AFB, MA 01731	<b>Sponsor/Monitor's Acronym(s)</b>	
	<b>Sponsor/Monitor's Report Number(s)</b>	
<b>Distribution/Availability Statement</b> Approved for public release, distribution unlimited		
<b>Supplementary Notes</b> Workshop paper from the New England Bioterrorism Preparedness Workshop held 3-4 april 2002 at MIT Lincoln Laboratory, Lexington, MA, The original document contains color images.		
<b>Abstract</b>		
<b>Subject Terms</b>		
<b>Report Classification</b> unclassified	<b>Classification of this page</b> unclassified	
<b>Classification of Abstract</b> unclassified	<b>Limitation of Abstract</b> SAR	
<b>Number of Pages</b> 29		

# Anthrax and Smallpox: Comparison of Two Outbreaks

- 1979 Sverdlovsk anthrax epidemic, officially explained by consumption of infected meat; military aerosol suspected
- 1972 Yugoslavia smallpox epidemic, started by a pilgrim returning from Mecca via Baghdad, site of unreported outbreak

# Key Problem = Late Diagnosis

1. What are the political causes?
2. What are the medical/professional causes?
3. What are the public communication causes?

# 1979 Sverdlovsk Epidemic

1992-1994 investigation of an  
“unnatural” outbreak of inhalational  
anthrax

# Sources of Evidence

- KGB list of 64 victims' names and addresses
- Interviews with families/neighbors of 56 victims
- Cemetery data
- Autopsy tissue data
- Hospital records (5 survivors)
- Local hospital and factory clinic lists
- Veterinary documents/animal deaths

16-I, 19-I, в мае было выявлено 20 больных (рис.3).

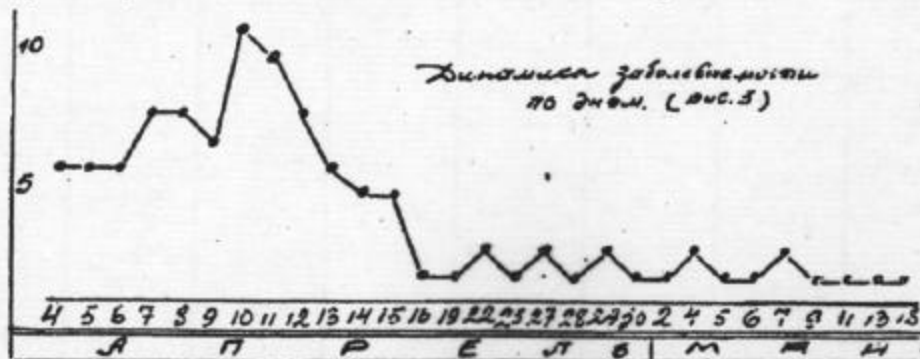

Распределение больных по датам с учетом непреодолимости инкубационного периода, позволило исключить инфицирование через мясо, поступавшее на питание населения в централизованном порядке. Ясно, что в этом случае следовало ожидать взрывообразное нарастание заболеваемости. Растянутый характер вспышка приняла из-за длительного хранения мяса населением. Так, в конце апреля в семье Г., состоящей из 2-х человек пенсионеров, о наличии мяса, купленного в начале месяца, удалось узнать только в итоге продолжительной беседы. Мясо в данном случае не вызвало опасений, поскольку уже несколько раз добавлялось при варке студня. В семье учительницы С. часть жирного мяса была перетоплена для получения сала, которое использовалось в пищу. Однако из мяса, изъятых в указанных семьях, было выделено два штамма возбудителя сибирской язвы. Информация населения, передававшаяся через местное радио и печать об опасности употребления случайно купленного мяса, создала уверенность в том, что мясо все изъято и уничтожено, не сохранилось у населения, это поэтому настоятельные меры для его выявления и изъятия не принимались. Вместе с тем, наблюдения в ряде очагов показали также возможность инфицирования

Page from Soviet report,  
1988, submitted to  
US State Department.  
April 4-May 16, 1979 cases  
reported as due to eating  
infected meat over weeks.  
Fatalities 64, survivors 15.

Anna Komina  
Ceramics factory  
worker, age 54;  
resident of  
affected district

Date of onset of  
symptoms: April 4

Date of death: April 10





Valentin Petrovich Borisov  
Age 27, Soldier, Compound 32



Pyotr Pilyasov, Age 39  
Construction worker



June, 1992, Hospital 20, in Ekaterinburg's southern Chkalovsky district. Team members Martin Hugh Jones, veterinarian, Alexis Shelokov, virologist, and Matthew Meselson, biochemist and team organizer, with a university host V. A. Shpetkin, and the hospital director, Margarita Ilyenko.



Street leading towards ceramics factory (smokestack in Center) where 18 workers died of anthrax, April-May 1979



1993. Interior of pipe shop of abandoned ceramics factory. Large, third-story windows on left face northwest.



Gate of Compound 19 military base, southwest Ekaterinburg. Soldier is allowing truck to enter.



Cottage in village southeast of Ekaterinburg where animals died of anthrax in 1979, starting April 5-6, and where villagers were vaccinated and quarantined.

Sverdlovsk, c.1985  
Red dots=Nighttime  
Locations of victims.  
Addresses obtained from  
KGB and other lists.  
Southern cluster is in  
Chkalovsky rayon.  
Arrows=homes off map.

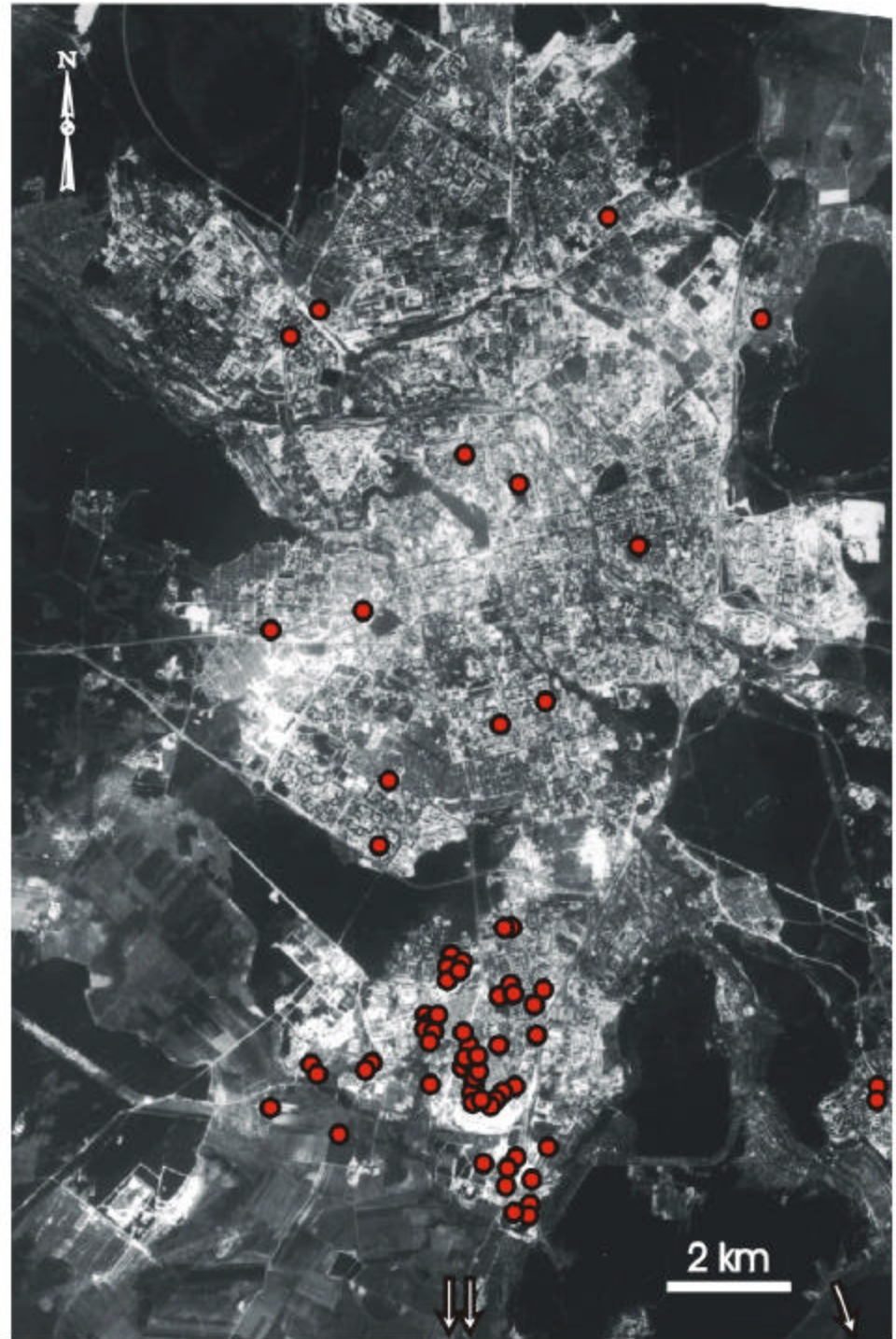

## Chkalovsky District Only (note inset of entire city)

Irregular white lines show  
Compounds 19 and 32.

White rectangle indicates  
Ceramics factory.

Red dots=daytime locations of  
66 victims and 11 survivors.



Six villages southeast of Sverdlovsk where 1979 epizootic occurred. Public health measures April through May. Interviews conducted at F, Abramovo, confirmed Veterinary documents.

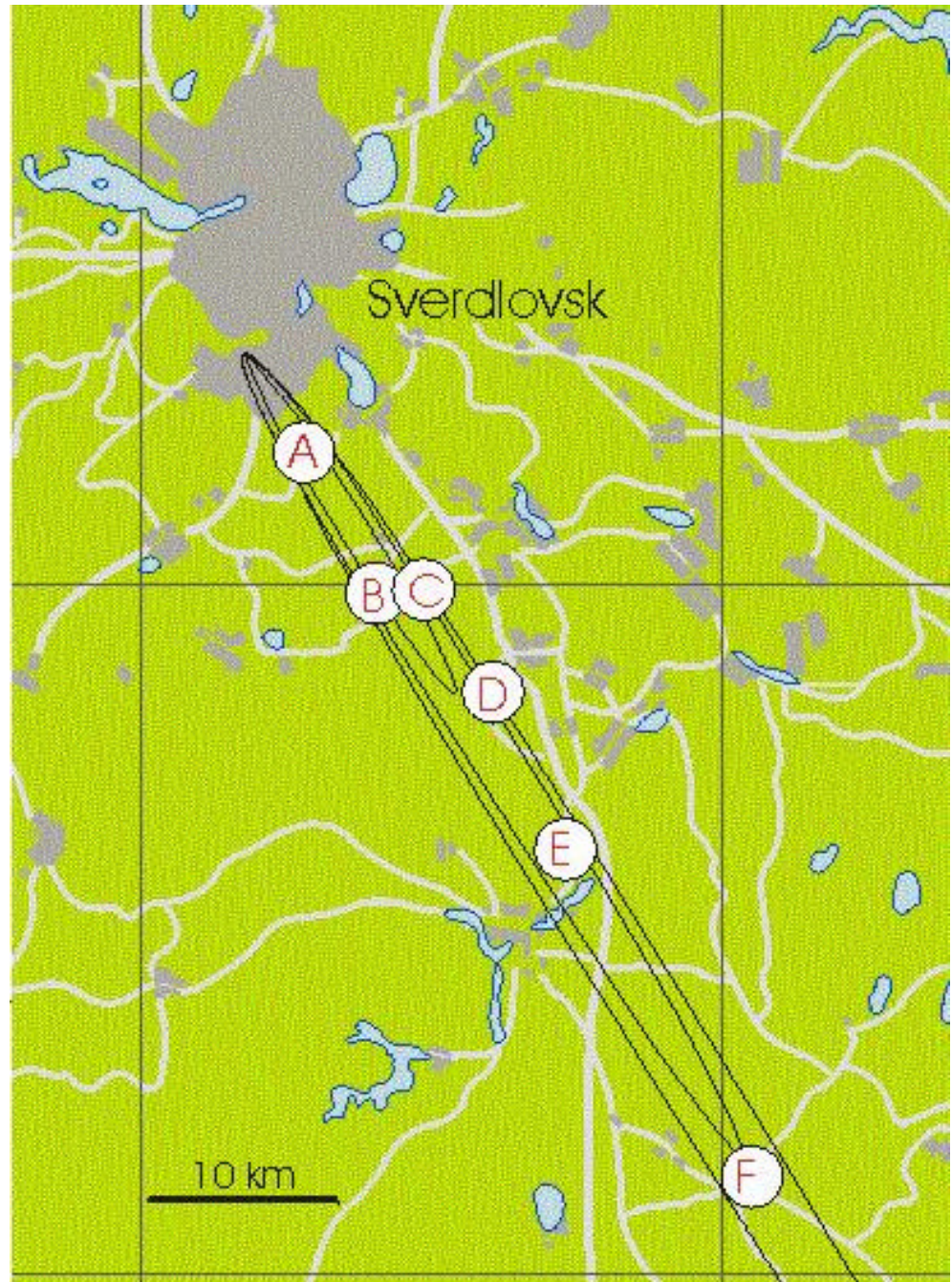

Friday March 30

360°

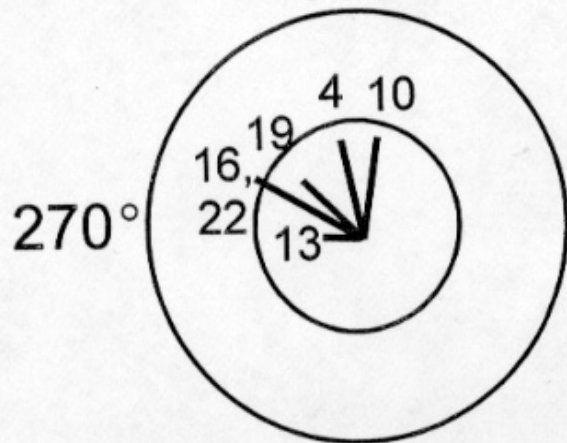

Saturday March 31

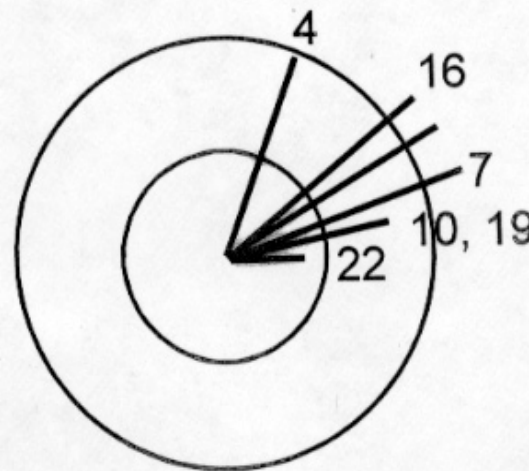

Sunday April 1

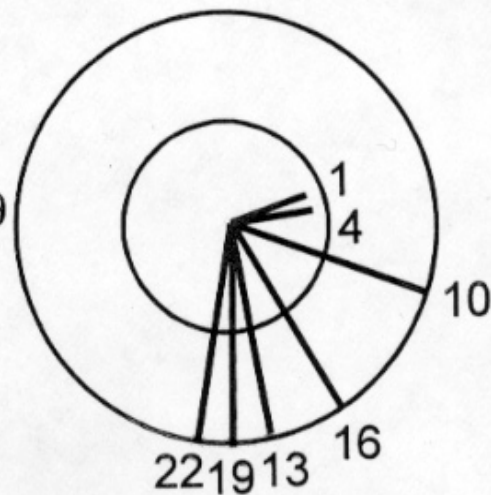

Monday April 2

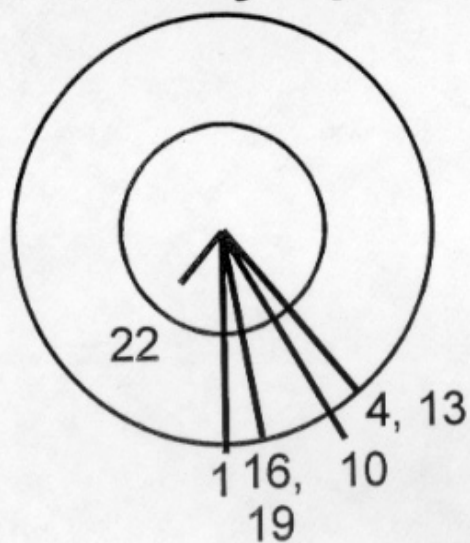

Tuesday April 3

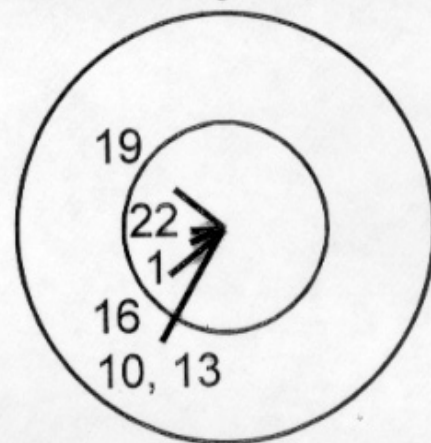

Wednesday April 4

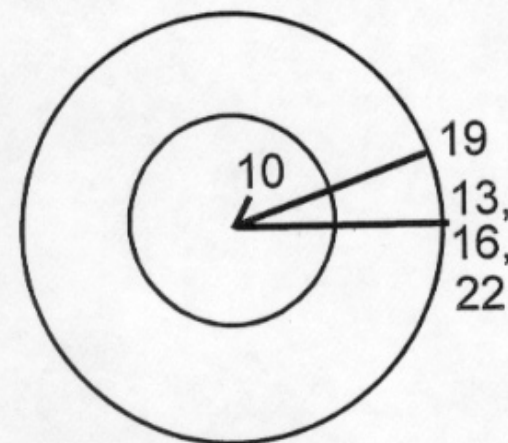

# Research Findings

- A lethal emission of anthrax spores from Compound 19 occurred during the afternoon of April 2, 1979.
- No young people under 24 or children were affected.
- Approximately 80 people (of some 5000 exposed) became infected; 11 survived with treatment.
- An estimated gram (a trillion spores) caused the fatalities; attack rate of 1-2%; fatality rate around 80% (note late diagnosis).
- Inhalation anthrax in humans can occur as long as 43 days after exposure. (First evidence in human cases)

## Soviet Public Health Response

- Urban: lab diagnosis, screening for central hospital intensive care and pediatric cases, ambulance transport, autopsy team; 4000 volunteers mobilized for disinfection and distribution of antibiotics; Moscow clinical team, vaccine campaign for 50,000; building exteriors washed.
- Rural: roadblocks, carcasses burnt, enforced human vaccination, animal sheds destroyed, 3-week village quarantine.

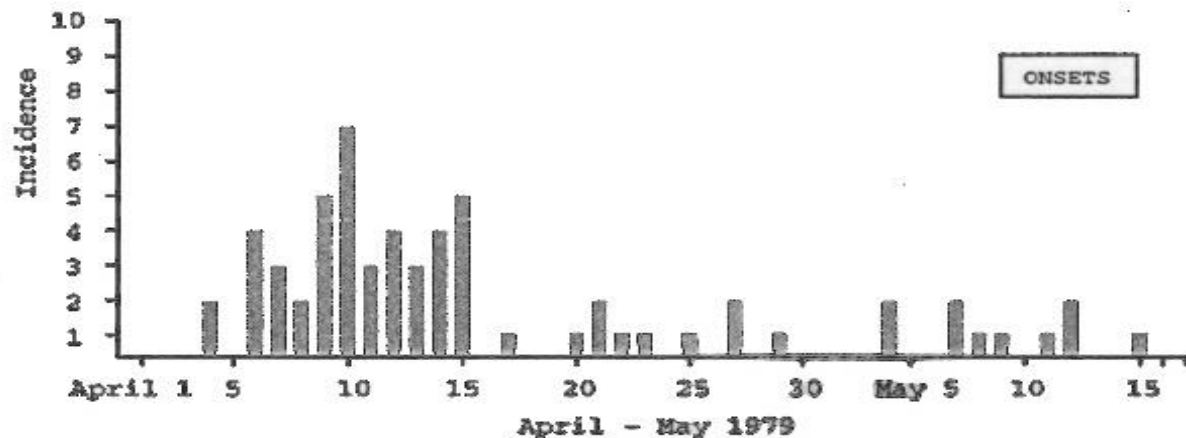

Diagnosis 9 days post  
April 2 exposure  
Total 21 deaths

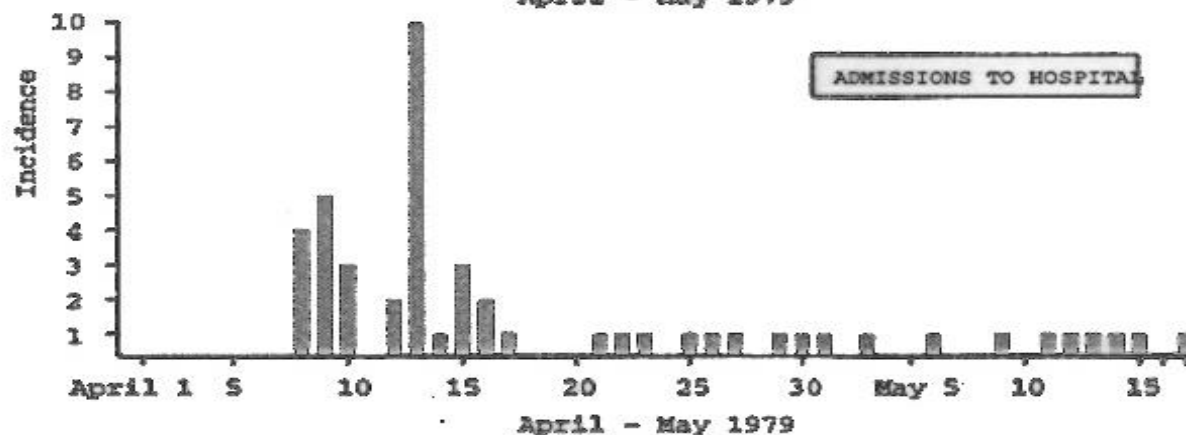

Moscow doctors  
April 12 arrival.  
Total 25 deaths

17 victims die with no  
hospital care

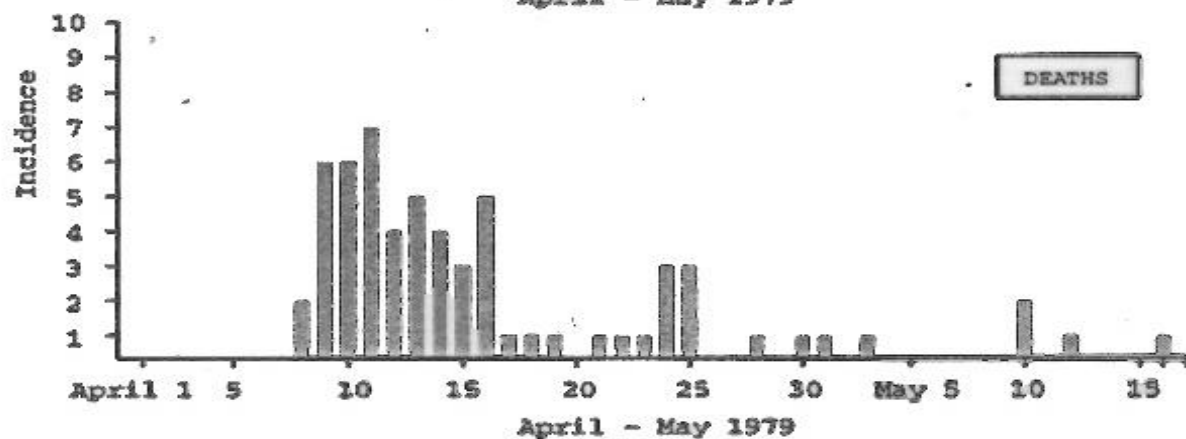

City clean-up begun.  
30,000 vaccinated.  
April 16,  
Total 42 deaths

Last recorded death  
May 16.  
Total 66 valid cases  
11 survivors

# Smallpox Epidemic Yugoslavia, 1972

Imported Virus Contagion  
“Natural Outbreak”

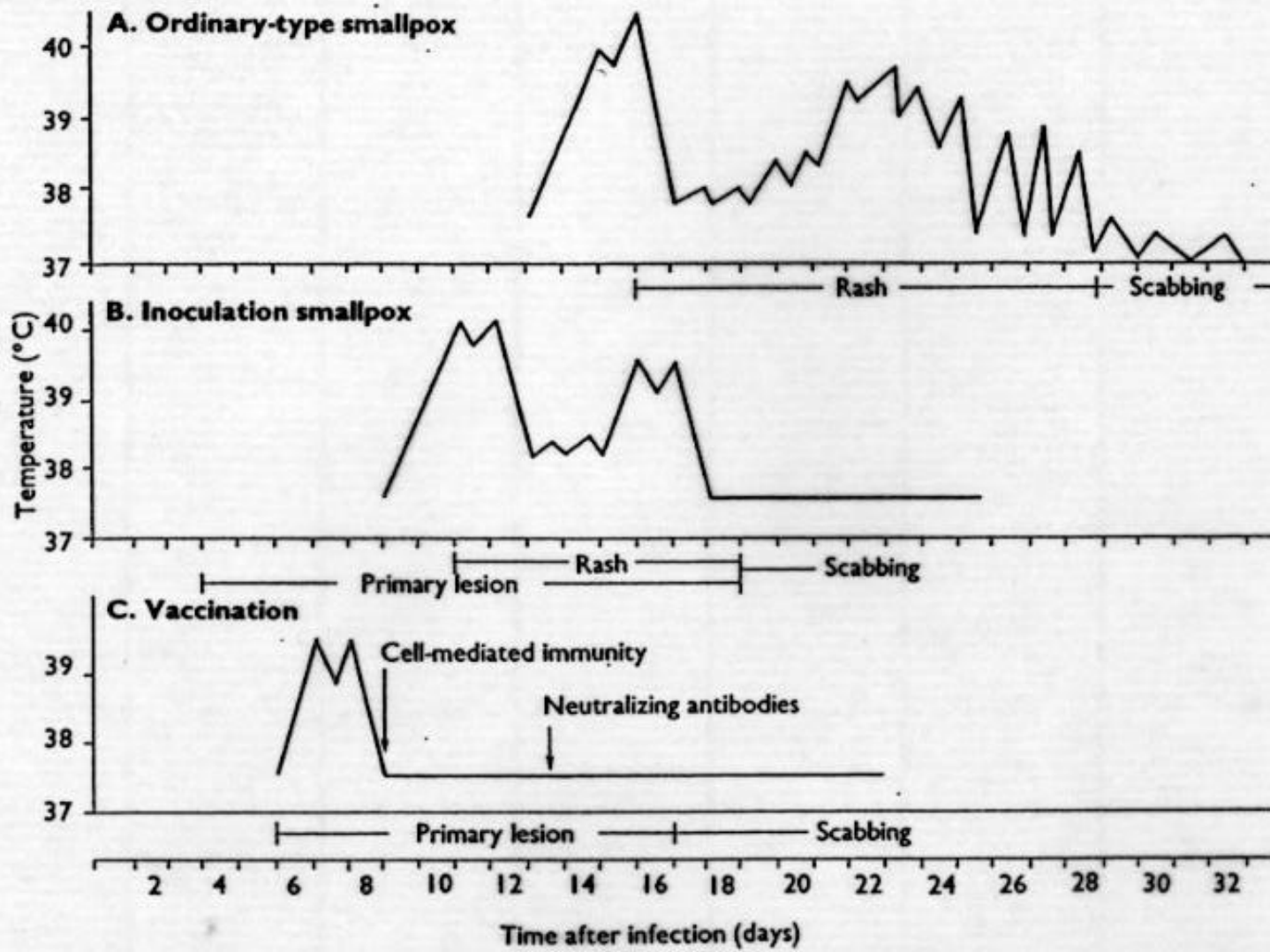

Fig. 1.3. The clinical course of moderately severe ordinary-type variola major in an unvaccinated subject (A); inoculation smallpox (variola) in an unvaccinated subject (B); and primary vaccination (C). (Temperature records from an illustration in Hime (1896) with modified wording.)

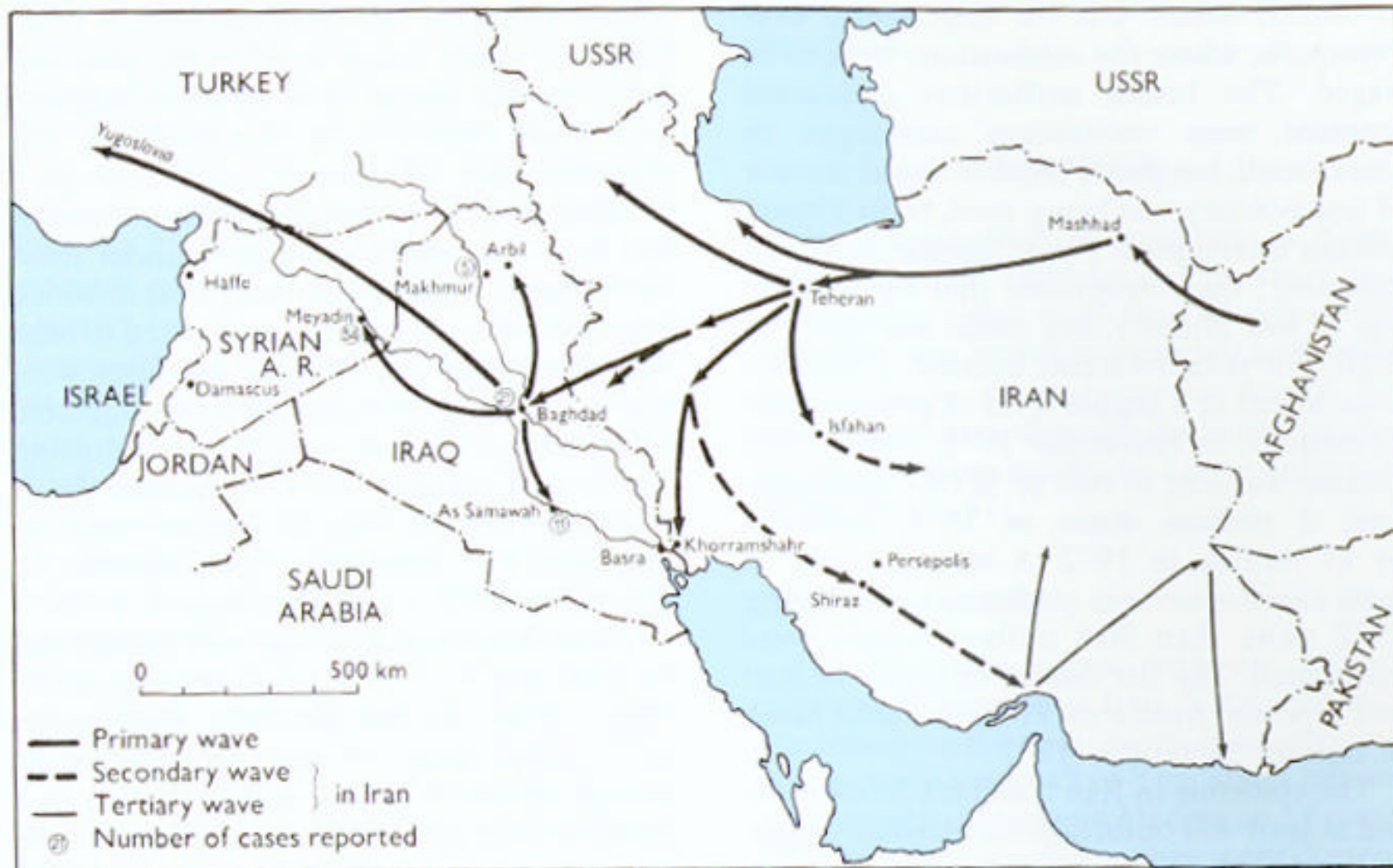
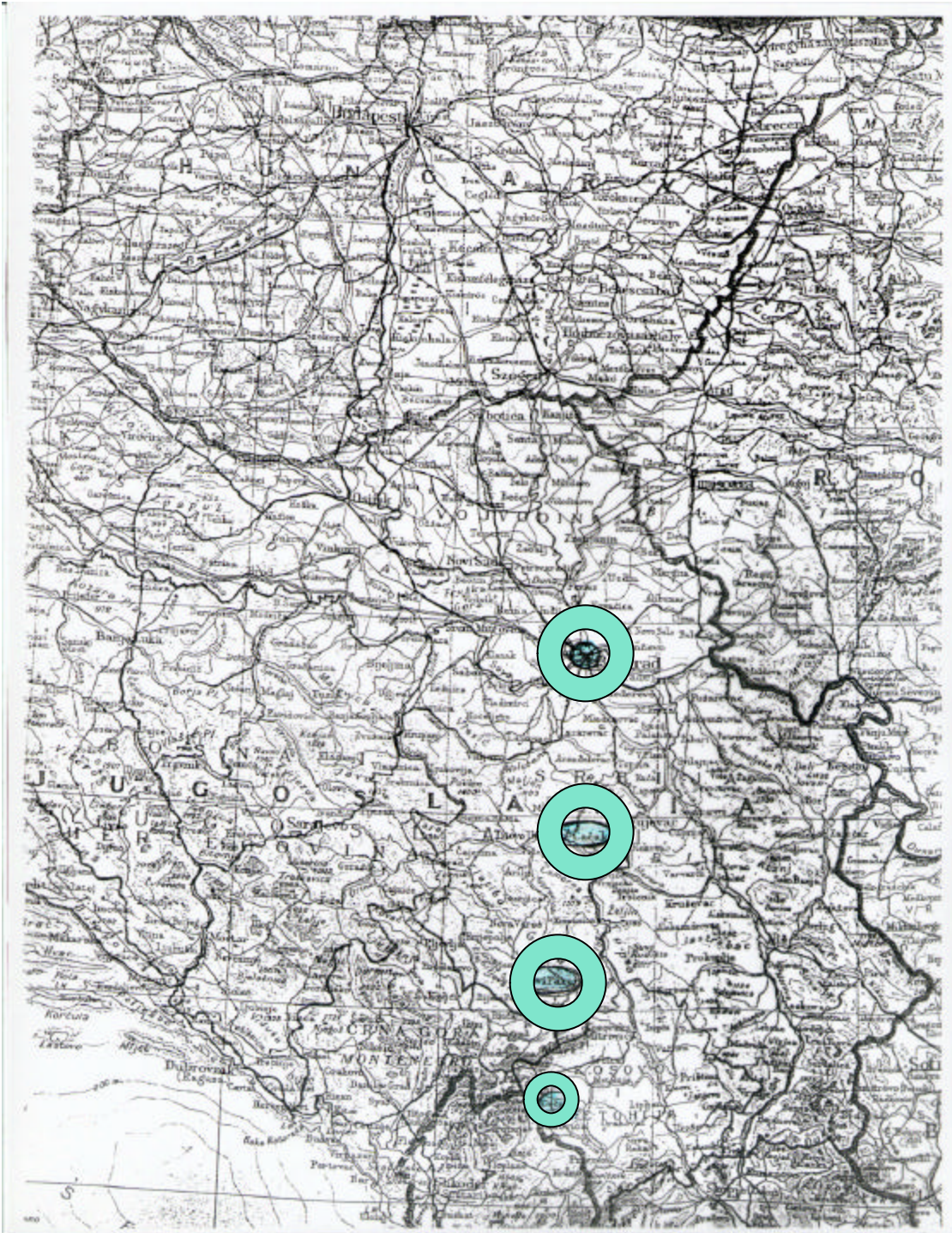

Fig. 23.5. Spread of smallpox in Iran, Iraq and the Syrian Arab Republic, 1970–1972. The disease was introduced from Afghanistan into Mashhad, Iran, in October 1970. There were three waves of dispersion through Iran, which lasted over a period of 22 months. By the end of 1971 smallpox had crossed into Iraq, where it spread north to Arbil and south to As Samawah. Transmission in Iraq was interrupted by June 1972. In February 1972, smallpox spread from Baghdad in Iraq to Meyadin in the Syrian Arab Republic, where a smaller outbreak occurred that was contained by June 1972.



Feb. 3-7 index case infected in Baghdad.

Feb.15-16 falls ill at home Danjani (Kosovo)

Mar.5 one of 11 infected by index case falls ill in Serbia

Mar.10 Serbian dies after infecting 42 in hospital

Mar.11, Serbia case total 10, Kosovo 12

Mar.13 physician in Kosovo sounds alert

**Mar.17 diagnosis and state containment initiative**

Mar.25 case total is 137

April 15 case total is 173 (123 Kosovo, 48 Serbia, 1 Vojvodina, 1 Montenegro)

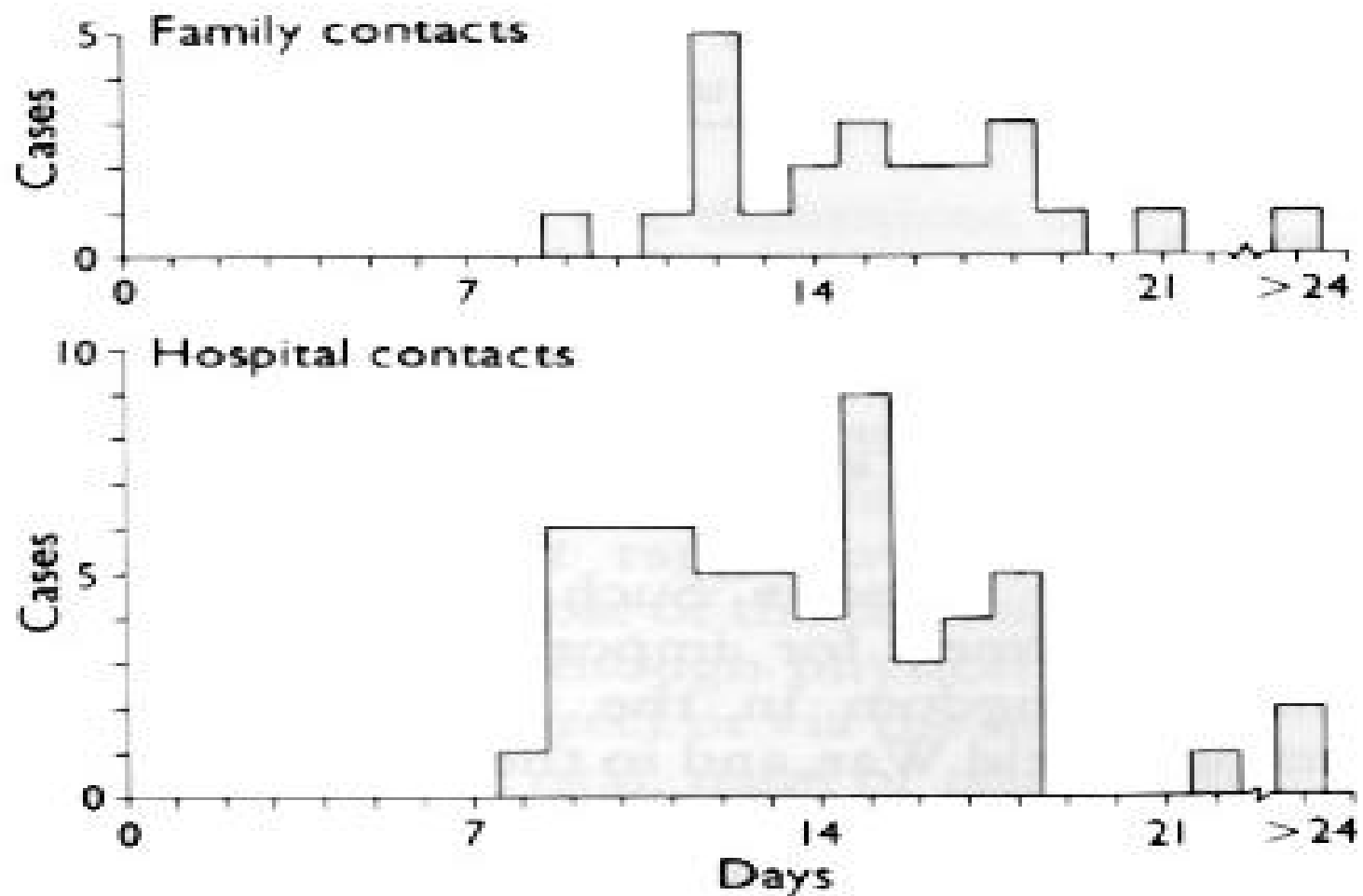

Fig. 4.8. The interval between the first possible exposure to a case of smallpox imported into Europe by air and the onset of symptoms in first generation indigenous cases, in family and hospital environments. (Based on Mack, 1972.)

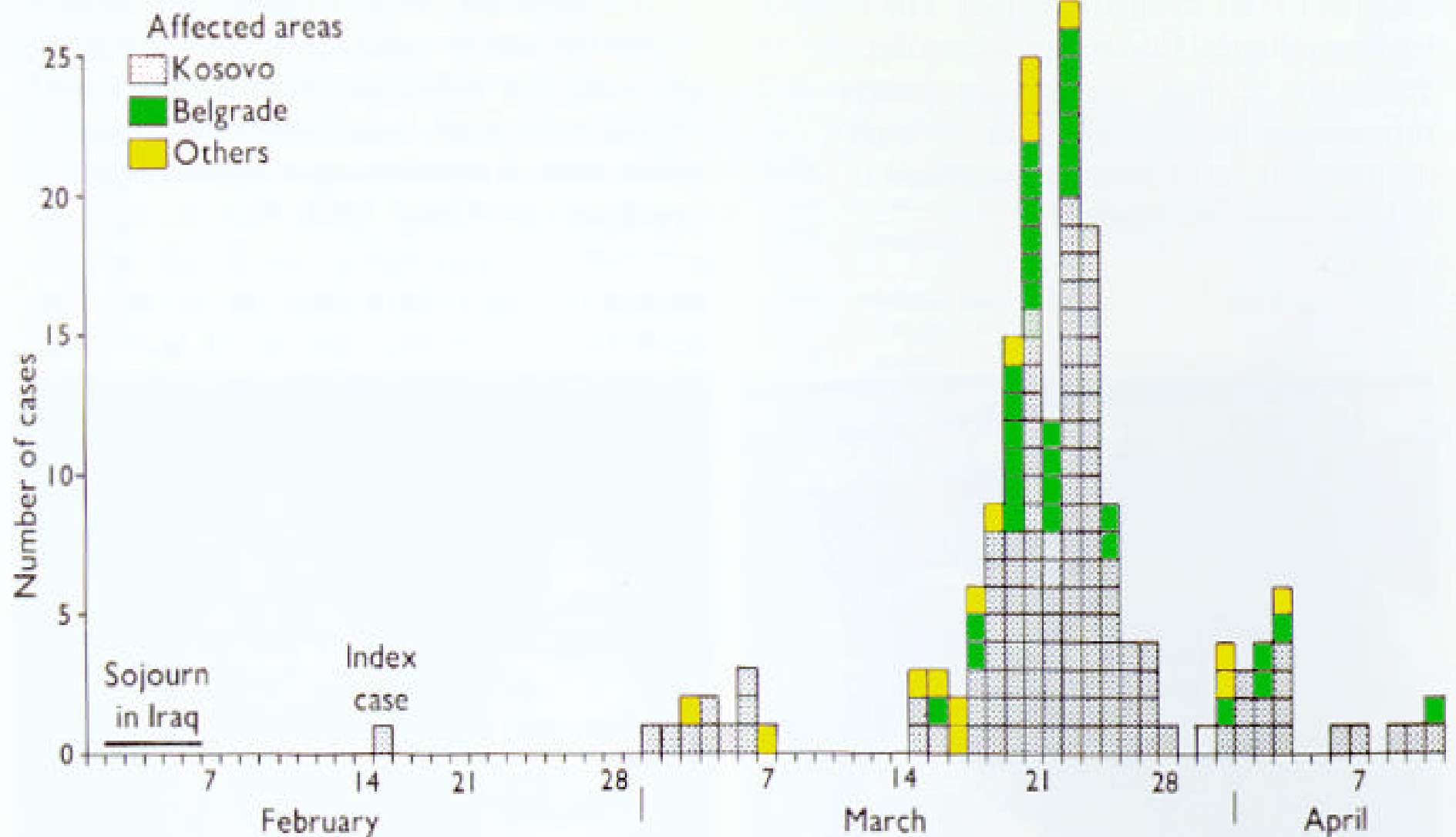

Fig. 23.7 Yugoslavia: number of cases of smallpox, by date of onset and locality, 1972. The first generation of cases occurred in Kosovo province and adjacent areas; the large second generation in Kosovo, Belgrade and some other places.



**Public Health Response**  
Mar. 15 to May 9  
Vaccine campaign,  
Quarantine, roadblocks.  
Belgrade team joins  
Kosovar local health staff  
(rural, many migrant  
workers) to begin  
concentric circles of  
Vaccinations in 25 foci,  
with family and village  
quarantine, prohibition  
of public meetings.  
18 million (of 20.8  
million citizens) were  
vaccinated in 3 weeks.  
175 cases, 35 dead (20%)  
case fatality rate. 37% of  
cases among previously  
vaccinated.

# Structural Sources of Late Diagnosis

- Political: military secrecy/religious repression
- Medical/Professional: lack of familiarity with disease (misdiagnosis)
- Communication: public uneducated about risk

# Solutions to Late Diagnosis

1. Political-public health cooperation
2. Medical technology and education
3. Accurate public communication