

ARMY RESEARCH LABORATORY



**ARL Commissioning Experiments With
a 4.5-MJ Pulsed Power Supply**

by Miguel Del Güercio

ARL-TR-2814

September 2002

Approved for public release; distribution is unlimited.

20020926 066

NOTICES

Disclaimers

The findings in this report are not to be construed as an official Department of the Army position unless so designated by other authorized documents.

Citation of manufacturer's or trade names does not constitute an official endorsement or approval of the use thereof.

Destroy this report when it is no longer needed. Do not return it to the originator.

Army Research Laboratory

Aberdeen Proving Ground, MD 21005-5066

ARL-TR-2814

September 2002

ARL Commissioning Experiments With a 4.5-MJ Pulsed Power Supply

Miguel Del Güercio
Weapons and Materials Research Directorate, ARL

Abstract

A 4.5-MJ capacitor-based, pulsed power supply has been installed at the U.S. Army Research Laboratory, Aberdeen Proving Ground, MD, for railgun operations. The system consists of 18 independent modules, each with an energy capacity of 250 kJ. Half of the modules were modified from their original condition to a pulse-forming inductance of $\sim 24 \mu\text{H}$, while the remainder maintained their original $60\text{-}\mu\text{H}$ inductance. Another modification included a pneumatic-operated shorting system, added to enhance the safety of the system. Simulations were conducted for a variety of load conditions using a SPICE-based code. Predicted currents and velocities are in reasonable agreement with measured quantities. The complete system allows the electromagnetic launch of hypervelocity launch packages to a downrange distance of 4 km.

Contents

List of Figures	v
1. Introduction	1
2. Hardware	2
2.1 Inductors.....	2
2.2 Diodes.....	2
2.3 Fuses.....	3
2.4 Controls.....	3
2.5 Spark Gap.....	5
2.6 HVCPS.....	5
2.7 Output Cables.....	5
2.8 Charge and Discharge Operations.....	6
3. Modeling	8
4. Experimental Results	9
5. Railgun Testing	11
6. Summary	12
7. References	13
Report Documentation Page	15

INTENTIONALLY LEFT BLANK.

List of Figures

Figure 1. PPS racks.....	1
Figure 2. Crowbar diodes and spark gap.	2
Figure 3. Fuses and trigger generators.	3
Figure 4. Local controller.	4
Figure 5. Control console/data acquisition.	4
Figure 6. Dry gas and monitoring panel–Interlock J-box and Interface J-box.	4
Figure 7. High-voltage (DC) control power supply.....	6
Figure 8. Module resistor/J-box/Ross relay.....	7
Figure 9. Module shorting system.	7
Figure 10. Safety soft dump/Ross probe.....	8
Figure 11. ICAPS module schematic.....	8
Figure 12. Simulation at 9 kV.....	9
Figure 13. Breech.....	9
Figure 14. Module 1 data vs. simulation.....	10
Figure 15. Rack 6 data vs. simulation.....	10
Figure 16. Railgun.	11
Figure 17. Current from railgun firings vs. code simulations.....	11

INTENTIONALLY LEFT BLANK.

1. Introduction

A 4.5-MJ pulsed power system (PPS), previously owned and operated by GDLS (General Dynamics Land Systems) for use on electrothermal-chemical (ETC) programs [1, 2], was acquired some time ago by the U.S. Army Research Laboratory-Weapons and Materials Research Directorate (ARL-WMRD). The system was recently modified to operate with an electromagnetic (EM) railgun, and the output of the pulser was modeled with a SPICE-based code (Intusoft ICAP/4Rx) [3].

This software reduces the long run times usually involved in these kind of simulations by means of a variable time-step control algorithm. The code [4] determines the in-bore projectile position, velocity, voltage and current at the breech all as a function of time up to muzzle exit. The code also includes a detailed model developed by the Institute for Advanced Technology (IAT) for the railgun [5]. The pulser's hardware consists of eighteen 250-kJ independently triggered modules. Pairs of these modules (see Figure 1) are symmetrically placed in nine racks (3 ft 7 in wide \times 13 ft long and 4 ft high). Each of the eighteen 250-kJ modules contains five Aerovox 11-kV/50-kJ, 830- μ F capacitors and two original 116- μ H inductors.

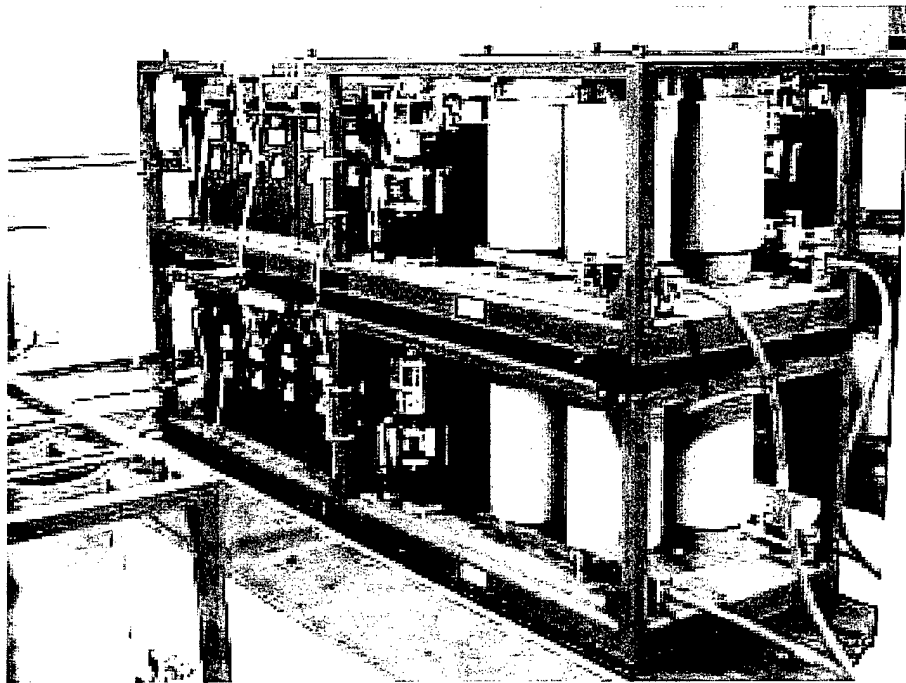

Figure 1. PPS racks.

2. Hardware

The PPS is composed of many subsystems and components. The following subsections address the parameters, physical characteristics and operating characteristics for a few of the most important components.

2.1 Inductors

The pulse-forming inductance was decreased on selected modules in an effort to generate an increase in peak launcher current and launch velocity. Nine of the eighteen modules retained their two original 116- μH inductors (connected in parallel). Nine 30- μH inductors replaced nine of the 116- μH inductors on the remaining nine modules. The final inductance for each of these modified modules was 24 μH . In general, many configurations are possible, as nine modules may have their twin inductors connected as single 116- μH inductors or in parallel as a 60- μH inductor, while the other nine modules can have their inductors connected as a single 116- μH , as a 30- μH , or in parallel as a 24- μH inductor (their present configuration).

2.2 Diodes

A total of fifteen Brown Boveri BBC Avalanche DSA 908-44 AG diodes, arranged in five stacks in parallel, with three diodes in series in each stack, form a crowbar diode set which protects the capacitors of each module from damaging voltage reversals (see Figure 2). Each diode is rated at 4.4 kV and 50 kA for a 1-ms half-sinusoid surge currents. Each crowbar diode set is clamped together and evenly distributed between two identical 1-in-thick aluminum circular plates.

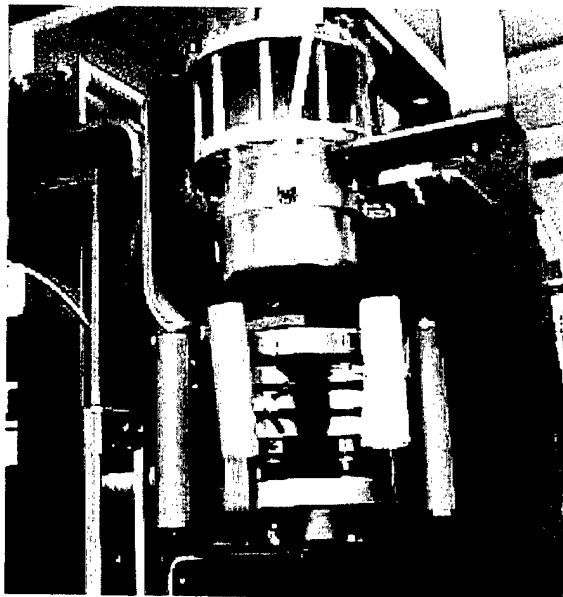

Figure 2. Crowbar diodes and spark gap.

There are three 0.01-mF capacitors connected in parallel and placed across the diode stacks. The capacitors provide extra protection for the diodes during large transients. Each of the five crowbar diode stacks is connected in series to a 15-m Ω resistor, providing a total of 3-m Ω crowbar resistance per module. The resistors limit the peak current through the diodes and moderate the action through the diodes, as these diodes become susceptible to failure when switching at large voltages.

2.3 Fuses

Four fuses are connected in parallel and placed in series with the output of each capacitor to enable the handling of large currents while providing isolation in the event of a capacitor short circuit at high voltages. Each Maxwell high-voltage fuse (see Figure 3) is rated at 6 kA and 22 kV, providing a maximum rating of 24 kA per assembly of four.

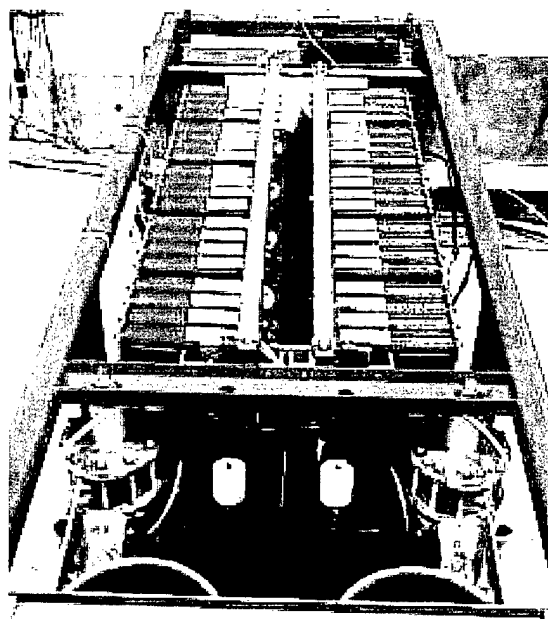

Figure 3. Fuses and trigger generators.

2.4 Controls

A local controller (see Figure 4) with state-of-the-art fiber-optic linked subsystems provides the hand-shake between the control consol (see Figure 5) via the Interface J-box (see Figure 6). All communications to and from the control consol to the J-box and to the J-boxes at each module are via fiber optics.

Data acquisition set-up (see Figure 5) includes four 4094A Nicolet oscilloscopes, providing a total of 16 channels. Data acquired are transferred from the 4094A oscilloscopes to the adjacent via the personal computer RS232 link in DOS mode.

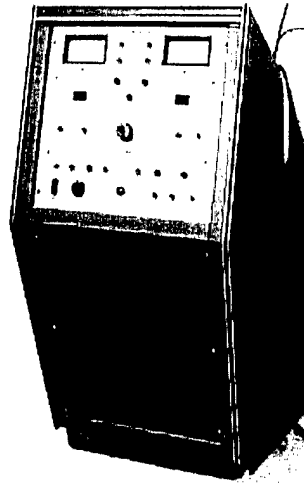

Figure 4. Local controller.

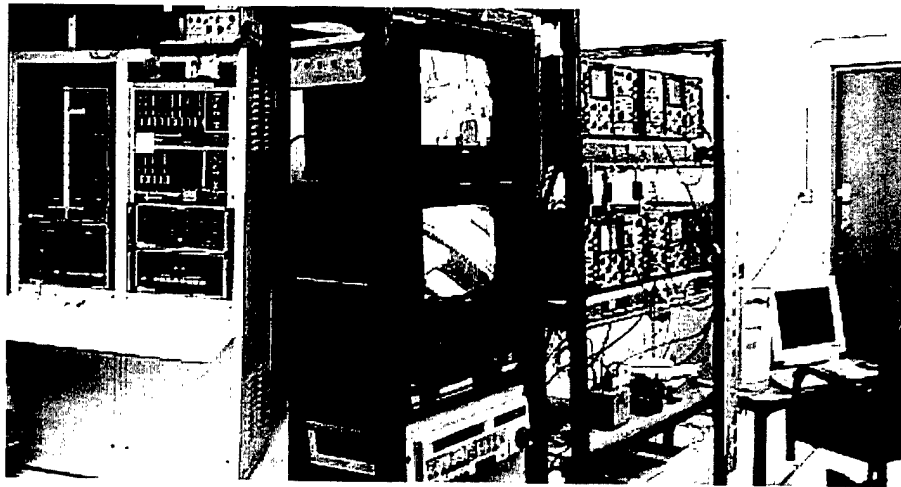

Figure 5. Control console/data acquisition.

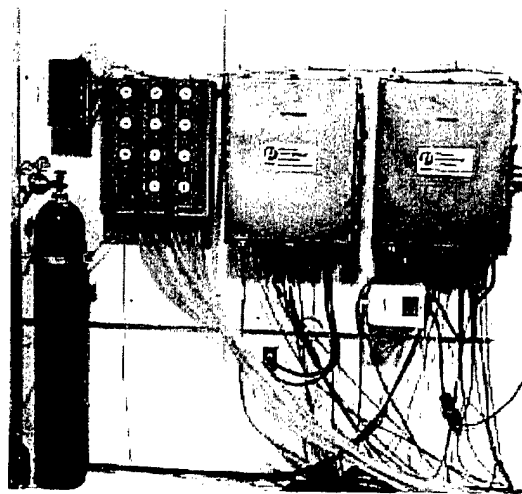

Figure 6. Dry gas and monitoring panel—Interlock J-box and Interface J-box.

Voltage-to-frequency circuitry boards are at three locations to communicate the optical signals: (1) the interlock chassis to allow high-voltage charging power supply (HVCPS) set point transmission to the Interface J-box, (2) the Interface J-box for HVCPS charge voltage and current transmission to the consol control, (3) the module's Interface J-box for sensor and transmission purposes to the F/V chassis located in the Interface J-box (see Figure 6).

The control console contains six separate chassis: (1) the control chassis with the on/off system key switch and enable buttons, (2) the charge monitor panel displaying the real-time voltage and current data, (3) the charge monitor chassis, (4) the output monitor chassis, (5) an 18-channel delay generator that allows the firing of the modules at preselected times, and (6) the Interlock J-box that defeats any attempt of discharging the pulser if any interlock is not closed.

When the initial sequence of commands for a test has been successfully completed at the control consol, a "charge complete" is displayed, indicating that the banks have reached the desired charge set-point and are ready to be discharged. At that time, the trigger generator, which controls the firing times of the individual modules, is able to be triggered, provided a disconnect handshake returns from the HVCPS. However, if the fire pushbutton is not pressed within 4 minutes, an excess time counter, started when the key switch is turned to run will connect the dump resistors across the capacitors to ground depleting the energy stored in the capacitors.

2.5 Spark Gap

The discharge of each module is initiated by a high-voltage trigger generator (PI-TG-75S) and controlled by a spark gap (PI-ST-300), operating as an output switch. The trigger generators are located between the module's spark gaps (see Figure 3), use dry air (Figure 6) to prevent breakdown, and produce over 55 kV into a high-impedance load. Their trigger is enabled via fiber optics within a 600-ns time delay. The ST-300 spark gaps (Figure 2) are rated at 500 kA with a stand-off voltage of 22 kV at zero pressure and are reliably triggered with the 55-kV pulse from the trigger generator.

2.6 HVCPS

The time for charging this system to full voltage (11 kV) is about 60 s, with a maximum current of 15 A. Initially, the charging process starts in a constant current mode to reach the desired set point. Once the set point voltage is reached, the HVCPS (see Figure 7) switches to a constant voltage mode to regulate and hold the set-point voltage.

2.7 Output Cables

The pulser's discharge is conducted through 18 single coaxial cables (see Figure 15), which are 10.7 m long, six of which have a resistance of 6 m Ω (560 $\mu\Omega$ /m) and an inductance of 2.02 μ H (189 nH/m). These coaxial cables connect each module to the breech of the railgun.

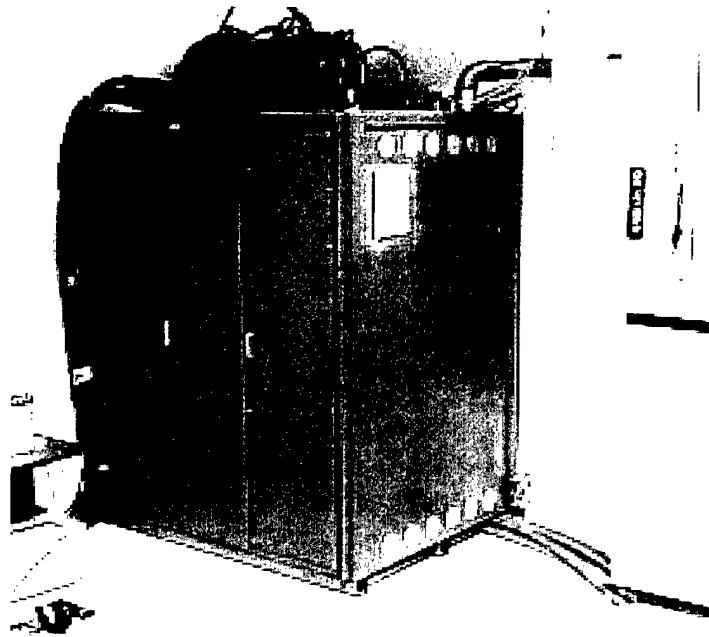

Figure 7. High-voltage (DC) control power supply.

2.8 Charge and Discharge Operations

Each module is charged and discharged safely through a heavy-duty 50- Ω (Allen Bradley) resistor (Figure 7). This operation is controlled by the module J-box as a Ross relay opens or closes. The resistor is capable of depleting 3 charges to full voltage within an hour period (Figure 8). A pneumatic shorting system was added at each module to eliminate the "hands on" shorting required after each firing. In the event of residual stored energy, the pneumatic system remotely depletes the energy in a rapid manner by physically lowering a grounded aluminum channel, thereby shorting the capacitor's terminal to the capacitor's case (rack's ground bus). Each of the aluminum channels are mechanically operated by two air cylinders positioned at opposite ends. At the lower position, the channel presses on an array of copper contacts (Figure 9) secured to each of the five mounting brackets that lock each set of four fuses to each capacitor's output terminal. Thus, in the event that a set of fuses for a capacitor is open circuited, the stored energy will be shorted directly to ground, possibly destroying the copper contacts but assuring that the energy in the capacitors is depleted. Previous to any work on the modules, a soft dump-rod (Figure 10) is used. A high-voltage Ross probe is also available for any potential troubleshooting hazard.

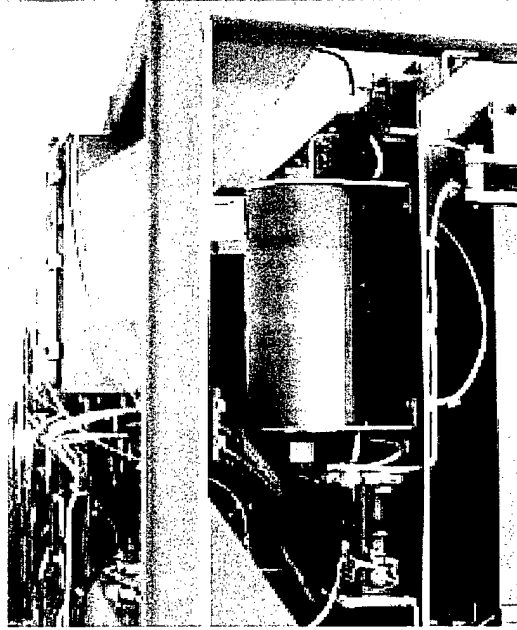

Figure 8. Module resistor/J-box/Ross relay.

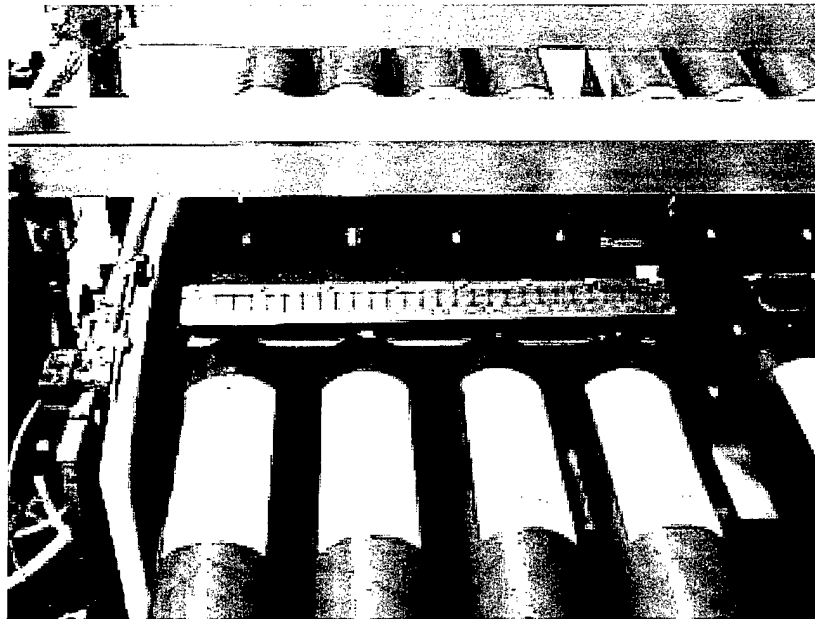

Figure 9. Module shorting system.

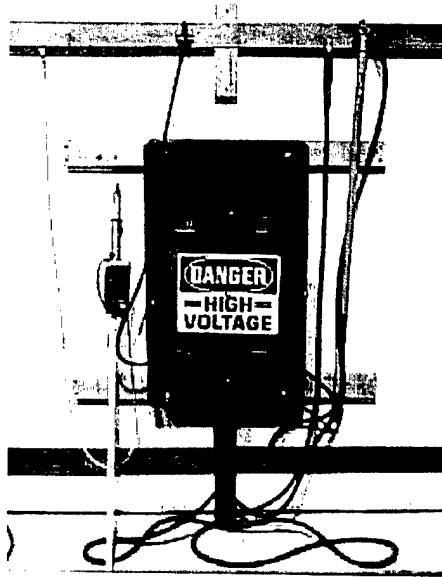

Figure 10. Safety soft dump/Ross probe.

3. Modeling

A non-net schematic of a module architecture is shown in Figure 11. The ICAPS software provided results in agreement with the initial tests, with a low impedance load connected at the breech. This initial data provided a coarse verification of the circuit performance. A simulation at an initial charge voltage of 9 kV (Figure 12), with a mass of 190 g and a rail length of 3 m, predicts a peak armature current of ~1.2 MA and an exit velocity of 2300 m/s.

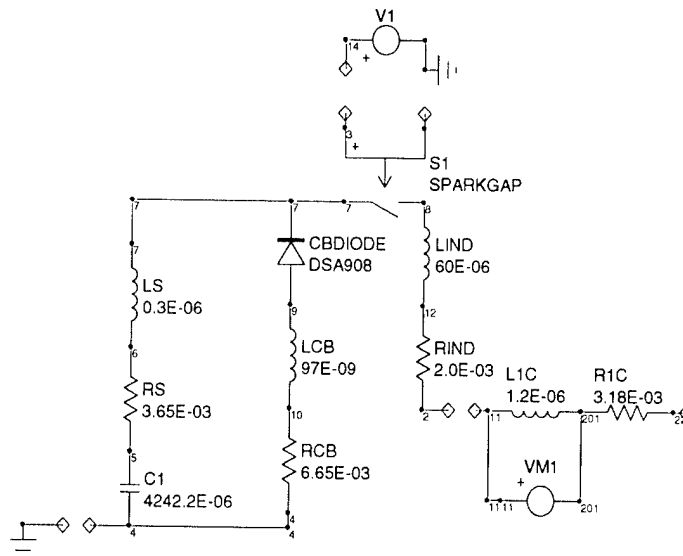

Figure 11. ICAPS module schematic.

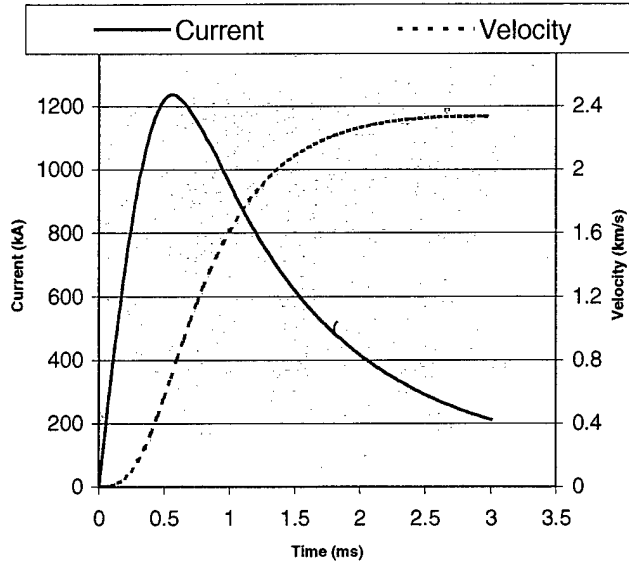

Figure 12. Simulation at 9 kV.

4. Experimental Results

Initial tests were done by discharging the individual modules into a low-impedance load at the breech (Figure 13). In general, good agreement was obtained between the ICAPS simulations and the current output.

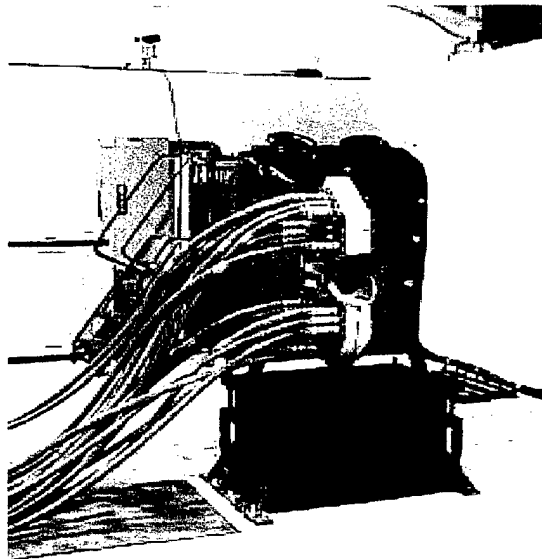

Figure 13. Breech.

At an initial charge voltage of 3 kV, the experimental data from module 1, rack 1 with a 30- μH inductor, and a 116 μH in parallel ($\sim 24 \mu\text{H}$), show a lower peak of 29.3 kA at 519 μs than its simulated value of 31.1 kA (Figure 14).

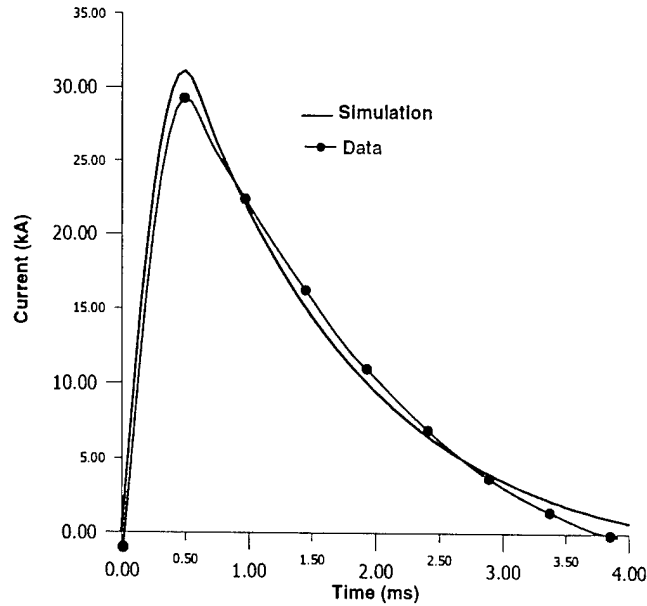

Figure 14. Module 1 data vs. simulation.

The output current for modules 11 and 12, also at an initial charge voltage of 3 kV (rack 6) and each with two parallel 116 μH inductors ($\sim 60 \mu\text{H}$), is shown in Figure 15. The larger inductance of these modules produced a later peak at 820 μs with a good match of peak values between experimental and simulated data (42.6 kA vs. 42 kA).

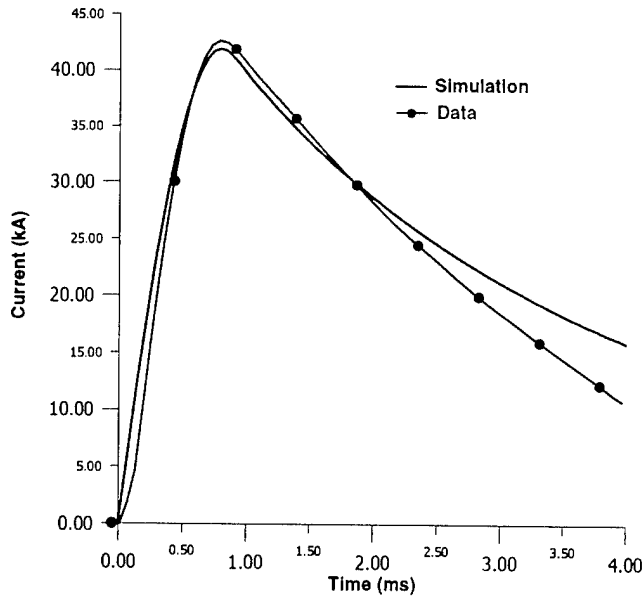

Figure 15. Rack 6 data vs. simulation.

5. Railgun Testing

Two initial tests at 5 and 6.5 kV were performed with a simple electromagnetic railgun, a 230-g solid armature, and a target placed at 50 m. Figure 16 shows the railgun and its connection to the breech.

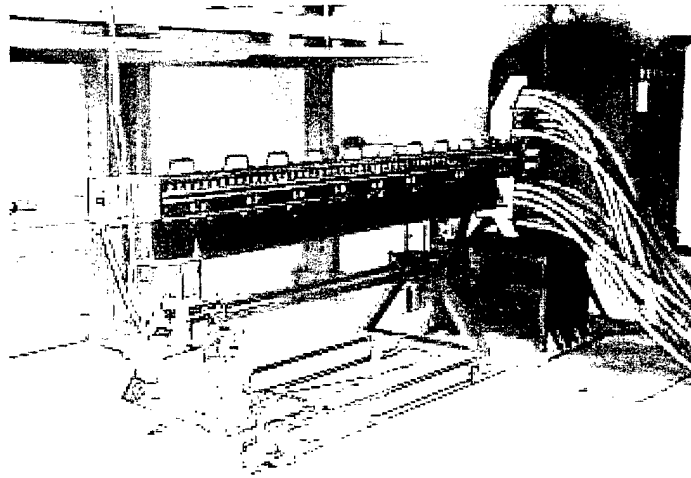

Figure 16. Railgun.

Data show muzzle velocities and peak currents of 880 m/s at 722.5 kA and 1000 m/s at 481 kA (delayed pulse), respectively. The code-generated simulations (Figure 17) reveal good agreement with the experimental data.

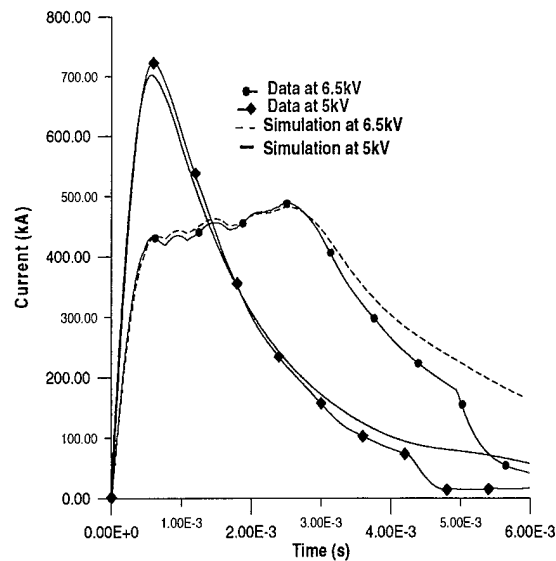

Figure 17. Current from railgun firings vs. code simulations.

6. Summary

A capacitor-based power supply previously used for ETC launchers and placed in storage for six years was successfully recommissioned. Additionally, the supply was used to provide currents and pulse shapes amenable to solid armature experiments. Peak performance to date included an 8-kV charge voltage. With all banks discharged at time zero and a 5-kV initial charge voltage, the peak current was 871 kA; using a time delay for each module, a nearly flat pulse was attained with a peak current of 611 kA and an initial charge voltage of 6.5 kV. Firings with different configurations of solid armatures of diverse weight (133–371 g), with all banks discharged simultaneously or delayed, showed a close agreement with their code simulations.

7. References

1. Hammon, H. G., D. Bhasavanich, and F. T. Warren. "Design Approaches to Pulsed Power for Electromagnetic and Electrothermal Gun Systems." Proceedings Pulsed Power Conference, San Leandro, CA, 1991.
2. Bhasavanich, D., D. F. Strachan, and R. Ford. "4.5 MJ Modular Pulse Power Supply for ETC Gun Applications." Proceedings Pulsed Power Conference, San Leandro, CA, 1993.
3. ICAP/4Rx, ICAPS, and SPICE4 are trademarks of Intusoft, San Pedro, CA, 90733-0710.
4. Del Güercio, M. "A SPICE-Based Code for ARL's 4.5-MJ Electromagnetic Launcher Pulsed Power Supply System." ARL-TR-2592, U.S. Army Research Laboratory, Aberdeen Proving Ground, MD, September 2001.
5. Schroder, K. A. "Study of Possible Power Supply Module Upgrade at the IAT Electromagnetic Research Laboratory." IAT.TM 0051, IAT at The University of Texas at Austin, February 2000.

INTENTIONALLY LEFT BLANK.

REPORT DOCUMENTATION PAGE

Form Approved
OMB No. 0704-0188

Public reporting burden for this collection of information is estimated to average 1 hour per response, including the time for reviewing instructions, searching existing data sources, gathering and maintaining the data needed, and completing and reviewing the collection of information. Send comments regarding this burden estimate or any other aspect of this collection of information, including suggestions for reducing this burden, to Washington Headquarters Services, Directorate for Information Operations and Reports, 1215 Jefferson Davis Highway, Suite 1204, Arlington, VA 22202-4302, and to the Office of Management and Budget, Paperwork Reduction Project (0704-0188), Washington, DC 20503.

1. AGENCY USE ONLY (Leave blank)		2. REPORT DATE September 2002	3. REPORT TYPE AND DATES COVERED Final, February 2002–April 2002	
4. TITLE AND SUBTITLE ARL Commissioning Experiments With a 4.5-MJ Pulsed Power Supply			5. FUNDING NUMBERS 1L1622618.AH80	
6. AUTHOR(S) Miguel Del Güercio				
7. PERFORMING ORGANIZATION NAME(S) AND ADDRESS(ES) U.S. Army Research Laboratory ATTN: AMSRL-WM-BC Aberdeen Proving Ground, MD 21005-5066			8. PERFORMING ORGANIZATION REPORT NUMBER ARL-TR-2814	
9. SPONSORING/MONITORING AGENCY NAMES(S) AND ADDRESS(ES)			10. SPONSORING/MONITORING AGENCY REPORT NUMBER	
11. SUPPLEMENTARY NOTES				
12a. DISTRIBUTION/AVAILABILITY STATEMENT Approved for public release; distribution is unlimited.			12b. DISTRIBUTION CODE	
13. ABSTRACT (Maximum 200 words) A 4.5-MJ capacitor-based, pulsed power supply has been installed at the U.S. Army Research Laboratory, Aberdeen Proving Ground, MD, for railgun operations. The system consists of 18 independent modules, each with an energy capacity of 250 kJ. Half of the modules were modified from their original condition to a pulse-forming inductance of ~24 mH, while the remainder maintained their original 60-mH inductance. Another modification included a pneumatic-operated shorting system, added to enhance the safety of the system. Simulations were conducted for a variety of load conditions using a SPICE-based code. Predicted currents and velocities are in reasonable agreement with measured quantities. The complete system allows the electromagnetic launch of hypervelocity launch packages to a downrange distance of 4 km.				
14. SUBJECT TERMS electromagnetic launcher, pulsed power system, EM gun experiments			15. NUMBER OF PAGES 18	
			16. PRICE CODE	
17. SECURITY CLASSIFICATION OF REPORT UNCLASSIFIED	18. SECURITY CLASSIFICATION OF THIS PAGE UNCLASSIFIED	19. SECURITY CLASSIFICATION OF ABSTRACT UNCLASSIFIED	20. LIMITATION OF ABSTRACT UL	

INTENTIONALLY LEFT BLANK.