

REPORT DOCUMENTATION PAGE

Form Approved
OMB No. 0704-0188

Public reporting burden for this collection of information is estimated to average 1 hour per response, including the time for reviewing instructions, searching existing data sources, gathering and maintaining the data needed, and completing and reviewing this collection of information. Send comments regarding this burden estimate or any other aspect of this collection of information, including suggestions for reducing this burden to Department of Defense, Washington Headquarters Services, Directorate for Information Operations and Reports (0704-0188), 1215 Jefferson Davis Highway, Suite 1204, Arlington, VA 22202-4302. Respondents should be aware that notwithstanding any other provision of law, no person shall be subject to any penalty for failing to comply with a collection of information if it does not display a currently valid OMB control number. PLEASE DO NOT RETURN YOUR FORM TO THE ABOVE ADDRESS.

1. REPORT DATE (DD-MM-YYYY)		2. REPORT TYPE Technical Papers		3. DATES COVERED (From - To)	
4. TITLE AND SUBTITLE				5a. CONTRACT NUMBER	
				5b. GRANT NUMBER	
				5c. PROGRAM ELEMENT NUMBER	
6. AUTHOR(S)				5d. PROJECT NUMBER	
				5e. TASK NUMBER	
				5f. WORK UNIT NUMBER	
7. PERFORMING ORGANIZATION NAME(S) AND ADDRESS(ES) Air Force Research Laboratory (AFMC) AFRL/PRS 5 Pollux Drive Edwards AFB CA 93524-7048				8. PERFORMING ORGANIZATION REPORT	
9. SPONSORING / MONITORING AGENCY NAME(S) AND ADDRESS(ES) Air Force Research Laboratory (AFMC) AFRL/PRS 5 Pollux Drive Edwards AFB CA 93524-7048				10. SPONSOR/MONITOR'S ACRONYM(S)	
				11. SPONSOR/MONITOR'S NUMBER(S)	

12. DISTRIBUTION / AVAILABILITY STATEMENT

Approved for public release; distribution unlimited.

6340RH65

ERC# E99-018 (no letter?)

*✓ Spreadsheet
✓ DTS*

MEMORANDUM FOR PRR (Contractor/In-House Publication)

FROM: PROI (TI) (STINFO)

2 June 1999

SUBJECT: Authorization for Release of Technical Information, Control Number: AFRL-PR-ED-TP-FY99-0128
Dulligan, Johnson, Zimmerman, Sajovich, and Bromaghim, AIAA-99-2708, "Electromagnetic Effects of the ESEX 26 kW Ammonia Arcjet on Normal Spacecraft Communications and Operations"

AIAA Joint Propulsion Conference

(Public Release)

20020823 041

15. SUBJECT TERMS

16. SECURITY CLASSIFICATION OF:

a. REPORT	b. ABSTRACT	c. THIS PAGE
Unclassified	Unclassified	Unclassified

17. LIMITATION OF ABSTRACT

A

18. NUMBER OF PAGES

19a. NAME OF RESPONSIBLE PERSON

Leilani Richardson

19b. TELEPHONE NUMBER
(include area code)
(661) 275-5015

41 items enclosed



AIAA 99-2708

**Electromagnetic Effects of the ESEX 26 kW
Ammonia Arcjet on Normal Spacecraft
Communications and Operations**

M.J. Dulligan,
ERC, Inc.
USAF Research Laboratory
Edwards AFB, CA

L.K. Johnson
The Aerospace Corporation
El Segundo, CA

J.A. Zimmerman, R.M. Salasovich, D.R. Bromaghim
USAF Research Laboratory
Edwards AFB, CA

**35th AIAA/ASME/SAE/ASEE Joint Propulsion
Conference and Exhibit
20-24 June 1999
Los Angeles, California**

ELECTROMAGNETIC EFFECTS OF THE ESEX 26 kW AMMONIA ARCJET ON
NORMAL SPACECRAFT COMMUNICATIONS AND OPERATIONS

M.J. Dulligan,* ERC, Inc., USAF Research Laboratory, Edwards AFB, CA 93524

J.A. Zimmerman,* R.M. Salasovich, D.R. Bromaghim,* USAF Research Laboratory, Edwards
AFB, CA 93524

L.K. Johnson, The Aerospace Corporation, El Segundo, CA 92957

*denotes Member AIAA; ranks

Abstract

Arcjet thrusters employ an arc discharge to heat propellant which expands through a nozzle to produce thrust. Spacecraft designers who desire to exploit arcjet technology have expressed concern about interference from the electromagnetic environment produced by the thrusters. One of the four major interest areas of the ESEX program was to determine the electromagnetic effect of operating a 30 kW class arcjet upon normal spacecraft communications and operations. To accomplish this task, noise levels were recorded in four frequency bands (2, 4, 8, and 12 GHz) by two onboard antennas. The electromagnetic noise levels observed during all arcjet firings were indistinguishable from those observed during the baseline non-firing periods. Communication bit error rates were also measured during arcjet firings and comparison with non-firing BER data revealed that spacecraft command and control communications were not significantly affected by arcjet firings. *define OK*

Introduction

The Electric Propulsion Space Experiment (ESEX) is a 30 kW ammonia arcjet sponsored by the USAF Research Laboratory with TRW as the prime contractor. The experiment objectives (which were all met) were to demonstrate the feasibility and compatibility of a high power arcjet system, as well as measure and record flight data for subsequent comparison *to with* ground results. The flight diagnostic suite included four thermo-electrically-cooled quartz crystal microbalance (TQCM) sensors, four radiometers, deck and boom mounted electromagnetic interference (EMI) antennas, a section of eight gallium-arsenide (Ga-As) solar array cells, a video camera, and an accelerometer. ESEX is one of nine experiments launched on 23 Feb 99 on the USAF's Advanced Research and Global Observation Satellite (ARGOS). ARGOS was launched on a Delta II into a 460 nautical mile, 98.7° inclination orbit and operated from the RDT&E Support Complex (RSC) at the USAF Space and Missile Test and Evaluation Directorate at Kirtland AFB, NM.

The ESEX flight system, Figure 1, included a propellant feed system, power subsystem - including the power conditioning unit (PCU) and the silver-zinc batteries, commanding and telemetry modules, the on-board diagnostics discussed above, and the arcjet assembly. ESEX was designed and built as a self-contained experiment - thermally isolated from ARGOS to minimize any effects from the arcjet firings. This design allowed ESEX to function autonomously, requiring support only for attitude control, communications, radiation-hardened data storage, and housekeeping power for functions such as battery charging and thermal control. A general results summary is provided by D.R. Bromaghim, *et al.*¹

Figure 1. Exploded view of the ESEX flight unit.

Spacecraft engineers, with the responsibility to ensure the compatibility of spacecraft systems and payloads, have questioned the EMI characteristics of arcjets. Electromagnetic signatures of low power arcjets have been studied in detail by NASA and TRW in ground tests^{2,3} and a 30 kW class arcjet was ground tested by the AFRL.⁴ This report concerns the ESEX objective to determine the influence of on-orbit arcjet firing upon spacecraft communication. Two types of quantitative measurements were conducted. Onboard antennas measured electromagnetic radiation in the gigahertz range communications bands during all eight arcjet firings. Bit error rates were measured during both arcjet firing and non-firing periods to study the impact of arcjet operation on normal spacecraft communications. The 30 kW class arcjet manifested aboard ESEX is the same design as the arcjet ground-tested by the AFRL.

Experimental Equipment and Procedures

EMI Onboard Test Equipment

The EMI unit, designed by TRW, measures the RF noise levels received by onboard antennas and consists of an electronics unit, two spiral antennas (deck and boom mounted), and the connecting cables. The unit internally switches between the two RF inputs. The RF input frequency range is from 1.950 GHz to 12.300 GHz and the minimum detectable RF input level is -165 dBm (approximately the lower thermal noise limit)^{5,6} with a 15 dB dynamic range for both antennas. The selected input is then split into four frequency channels (2, 4, 8, and 12 GHz; +/- 5% bandwidth.) The output of these filter channels are then amplified and converted to digital words and serially transmitted out of the unit as telemetry points to the ARGOS data recorder. Before each arcjet firing, the calibration routine was invoked and in all cases, proper function of the unit electronics was verified. An experiment block diagram is shown in Figure 2.

Figure 2 - EMI Experiment Block Diagram.

The antenna locations are shown in Figure 3. The deck mounted antenna was placed on the diagnostic platform at a position in direct view of the arcjet anode, horizontally separated by 37.54 cm. The boom mounted antenna was placed on the tip of a boom that deployed after launch. This single deployment boom placed the antenna 138.5 cm from the arcjet.

Figure 3 - Antenna Positions A) Side View; B) Top View.

Bit Error Rate Test Procedure and Equipment

The impact of arcjet firing on normal communication was determined by comparing the measured bit error rate (BER) recorded for arcjet firing and non-firing periods. Mission controllers located in the RSC coordinated Camp Parks Communication Annex (CPCA) BER test activities with the remote tracking site (RTS) telemetry acquisition, commanding, and wideband data dump operations, illustrated in Figure 4. Prior to satellite rise, the space ground link system (SGLS) transponder is activated, broadcasting an S-band signal (in this case, 1.811768 GHz) from the satellite. The ground tracking station receives the signal, locks to it, and then transmits an S-band carrier wave (in this case, 2.2655 GHz.) All of the BER tests were conducted in the coherent mode for which the satellite oscillator becomes slaved to the ground transmitted master oscillator. A momentary loss of telemetry is noted by any RTS that is receiving a signal from the satellite when the frequency shift occurs. The ground station then applies the modulated signal to the carrier wave and initiates the BER test. The uplinked signal is mapped directly onto the downlinked carrier in a manner that bypasses the encryption scheme, thus avoiding problems associated with unknown numbers of sympathetic bit flips. Bit errors are recorded as a function of time with 1-second resolution.

Figure 4 – Overview of BER Test Assets. Advanced Research Global Observation Satellite (ARGOS); Electric Propulsion Space Experiment (ESEX); Space Ground Link System (SGLS); Camp Parks Communication Annex (CPCA); Remote Tracking Station (RTS); RDT&E Support Complex (RSC)

For the BER test, the pseudorandom noise (PRN) code, used for SGLS range and range rate data recording, is replaced by a 2047-bit pattern code. This code is designed to emulate normal data bit patterns and avoids signal resonances that can be established in the electronic equipment for cases in which the bit pattern period is too short, e.g., 010101. A bit comparer- (Fireberd 6000) generates the code and compares the transmitted and received patterns, recording the number of bit errors per second. The BER test in this configuration was proven in a trial with MSTI-3 and was successfully employed throughout the ESEX program for a variety of test conditions.⁷

The CPCA in Dublin, California served as the ground station for all BER tests. The 10 meter parabolic, prime focus antenna, "the B-side," has an uplink gain of 39.6 dB, a downlink gain of 23.6 dB, a beam width of 1.1 degrees, and a slew rate of 6 degrees per second.⁸ The parameter space of uplink transmitter power and modulation index were explored prior to the first arcjet firing to empirically establish values set for the remainder of the testing period. Attempts to vary the uplink power were frustrated by amplitude drifts during the tests because the Class C amplifier is designed only for constant, maximum output power rather than for variable control of the output power. The majority of BER test data was obtained with an output power of 200 W. The first two arcjet firing BER tests were conducted with an output power of 100 W. A modulation index of 0.6 was determined to be ideal and was used for the majority of baseline BER test data acquisition. At the minimum slant range, the number of errors per second was about 10, but for the limits of 30 seconds after acquisition of signal and 30 seconds prior to

loss of signal, the error rate was not high enough to force sync losses (the loss of data frame synchronization).

Results and Discussion

Onboard Antenna Measurements

The on-board antennas were designed to measure radiation emitted by the arcjet that might cause electromagnetic interference (EMI). Though data was gathered for each of the eight firings, during quiescent spacecraft periods, and during routine spacecraft operations, only slight variations were observed in the measured signals. All of the features observed during the course of ESEX are represented in data collected about the time of arcjet firing #7, as shown in Figure 5. The EMI unit is powered on approximately 10 minutes prior to arcjet ignition and remains active for 20 minutes. One minute after the EMI unit turns on, a calibration routine is run to verify the state of health of the electronics unit. This is characterized by a dip in the signal because the antenna inputs are taken offline, 22:01 to 22:02 Z in Figure 5.

In general, the deck and boom mounted antennas register identical data values, with the occasional exception of the 4 GHz channel, in which the deck antenna value is often one dBm lower than the boom antenna value. It should be noted that the resolution is 1 dBm and that fluctuations between neighboring values could be the result of radiation levels almost matching the threshold level between two digital bins. Such oscillations are observed between -164 dBm and -163 dBm in the 4 and 12 GHz boom mounted antenna data. The 8 GHz value is always the largest at -162 dBm and the 12 GHz data is almost always the smallest at -164 dBm, just one unit above the minimum digital output value.

TRW specified the input frequency channels to coincide with popular communication bands (S-band, X-band, etc.) for the purpose of identifying any electromagnetic interference generated by the operation of a high power arcjet. Comparison of the onboard antenna measurements for all eight arcjet firings with non-firing periods did not reveal any readily apparent differences, suggesting the operation of the 26 kW arcjet did not generate EMI signals in the measured bands. This result compares well with ground test data that show the majority of measurable signal at lower frequencies. A more in-depth analysis of the antenna data from both firing and non-firing periods will be conducted and presented at a later date.

Figure 5 – Representative EMI Measurements: Arcjet Firing #7, deck mounted antenna.

Bit Error Rate Test

The BER test enabled a quantified assessment of the effect of the arcjet on the satellite ranging channel. A series of baseline measurements were made while the arcjet was off, and with the vehicle in several transmit configurations for comparison with firing data. BER tests were conducted during arcjet firings #2, #4, and #7, shown in Figures 6, 7, and 8, respectively.

The BER data is displayed as the number of bit errors per second vs. time and trends proportionally with changes in slant range, the shortest distance from the ground station antenna to the satellite. Typical values are ~ 2000 nm when the satellite signal is acquired/fades and between 500 and 900 nm at the maximum elevation. The 0 of the abscissa is defined by the minimum slant range with negative values representing the rising satellite (decreasing slant range), and positive values representing the fading satellite (increasing slant range).

The traces shown in Figure 6 are BER curves from arcjet firing # 2 and a non-firing period. The two curves were obtained for sequential passes with a transmitter power of 100 W and a modulation index of 0.6. Serving as a non-firing baseline, the easterly satellite orbit had a maximum elevation of 29 degrees with a corresponding minimum slant range of 805 nm. The arcjet fired during the westerly orbit and was ignited prior to and continuously fired for the duration of the BER test. The maximum elevation was 33 degrees and the minimum slant range was 740 nm, one revolution after the easterly pass.

The variation in bit error rates for the baseline and arcjet firing passes are of nearly the same magnitude (about +/- 25 bit errors per second), with the notable exception at about 100 seconds after maximum elevation. The arcjet firing trace has five sync losses (errors in the synchronization frame) and three counts of 350 bit errors per second or more. It is possible that the increase in error may result from adverse effects of arcjet emissions; however, such sync losses and increases in error rate are also observed in several baseline BER curves. A detailed study of the baseline data is underway for the purpose of identifying the cause of the features in the arcjet BER curve.

Figure 6 – Arcjet Firing #7 BER curve displayed with non-firing baseline pass taken under similar conditions.

The BER curve taken during arcjet firing # 4 is shown in Figure 7. The transmitter power was 100 W with a modulation index of 0.6 and the easterly orbit had a maximum elevation of 67 degrees and minimum slant range of 497 nm. A prominent feature in this BER curve is the sudden reduction in bit error rate. The arcjet turns off 275 seconds after maximum elevation; however, a sudden decrease in bit error rate is noted about 20 seconds before that. The maximum error in the time axis is 8 seconds, too little to account for this difference in time. The BER test is extremely sensitive to transmitter power and it was noted that 1 dB change in output power causes more than a factor of 2 change in the measured BER. The CPCA high power amplifier is a Class C type and is susceptible to output power drifting when operated at less than full output power. This behavior was observed in the early stages of testing and may be the cause of the observed change in BER noted in Figure 7. Sync losses are represented by the curve dropping to 0 bit errors per second.

Figure 7 – Arcjet Firing #4 BER curve.

The final arcjet firing BER curve was obtained with a transmitter power of 200 W and a modulation index of 0.6. The westerly pass had a maximum elevation of 53 degrees and a minimum slant range of 550 nm. The BER test continuously recorded data before, during and after the arcjet firings. The two distinct arcjet firings are denoted by the shaded boxes in Figure

8. The overall error rate is reduced in this trace, as compared to the earlier data because of the increased transmitter power. The bit error rate shown under the left hand shaded box does not differ substantially from either baseline error rates (either side of the shaded areas); however, the error rate seems to increase for the right hand shaded box. This may be the result of atypical arcjet operation, as it is known that the arcjet firing terminated prematurely due to insufficient battery energy. The arcjet was operating out of specification and may have been generating unusual EMI. In addition, it should be noted that the initial arcjet shut down and reignition were unintentional. The arcjet was intended to continuously fire for 5 minutes, but because of battery problems, it shut itself down and reignited one time.

Figure 8 – Arcjet Firing # 7 BER curve.

In summary, three arcjet firings and over ³⁰thirty baseline BER curves were recorded during the ESEX flight. Preliminary analysis of the data did not reveal a clear correlation between features observed in the arcjet firing curves and the operation of the arcjet. Similar features are identifiable in the baseline BER curves. Further analysis must be conducted to determine the causes of the observed features before the impact of arcjet operation on communications will be understood.

Conclusions

All of the electromagnetic interference test objectives were achieved. Though further analysis of the BER data may prove otherwise, no indication that the arcjet adversely affects normal spacecraft communications and operations was clearly identified. The 30 kW class arcjet operated satisfactorily in the space environment and the onboard antennas did not register data values that differed from firing to non-firing periods, suggesting low EMI arcjet output. The BER curves from arcjet firing and non-firing periods differ slightly, but more data analysis is required before a firm conclusion may be drawn. However, it is unlikely that operation of a 30 ⁹⁹ kW class arcjet will adversely affect normal spacecraft communications.

Acknowledgements

This work was supported by the ARGOS and ESEX program offices. The authors would like to thank Dave Hardesty, Jerry Jenkins, John Fugelein, Chris Autry, and Luke Costello of the CPCA for their outstanding technical support. Useful discussions were held with Robert Therriault from Kirtland AFB and Howard Lacy from Boeing.

References

1. D.R. Bromaghim, J.R. LeDuc, R.M. Salasovich, J.A. Zimmerman, D.C. Matias, A.M. Sutton, G.G. Spanjers, J.M. Fife, W.H. Hargus, R.A. Spores, L.K. Johnson, M.J. Dulligan, S.F. Engelman, J.H. Schilling, and D.C. White, "An Overview of the On-Orbit Results from the ESEX Flight Experiment," AIAA-99-2706, June 20, 1999 and references therein.

2. E.J. Pencil, C.J. Sarmiento, D.A. Lichtin, J.W. Palchefskey, and A.L. Bogorad, "Low Power Arcjet System Spacecraft Impacts," AIAA-93-2392, June 1993.
3. S. Zafran, "Hydrazine Arcjet Propulsion System Integration Testing," International Electric Propulsion Conference, Paper 91-013, Oct. 1991.
4. L.K. Johnson, A. Rivera, M. Lundquist, T.M. Sanks, A. Sutton, D.R. Bromaghim, "Frequency-Domain Electromagnetic Characteristics of a 26-Kilowatt Ammonia Arcjet," Journal of Spacecraft and Rockets, January 1996, Vol. 33, pages 137-143.
5. "30 kWe Class Arcjet Advanced Technology Transition Development User Manual", TRW Space and Electronics Group, Redondo Beach, CA 90278, August 31, 1997.
6. Private communication with Mary Kriebel.
7. MSTI-3 reference ?
8. "Camp Parks Test Facility," Camp Parks Communication Annex, Dublin, CA, 1997 brochure.

Fig1

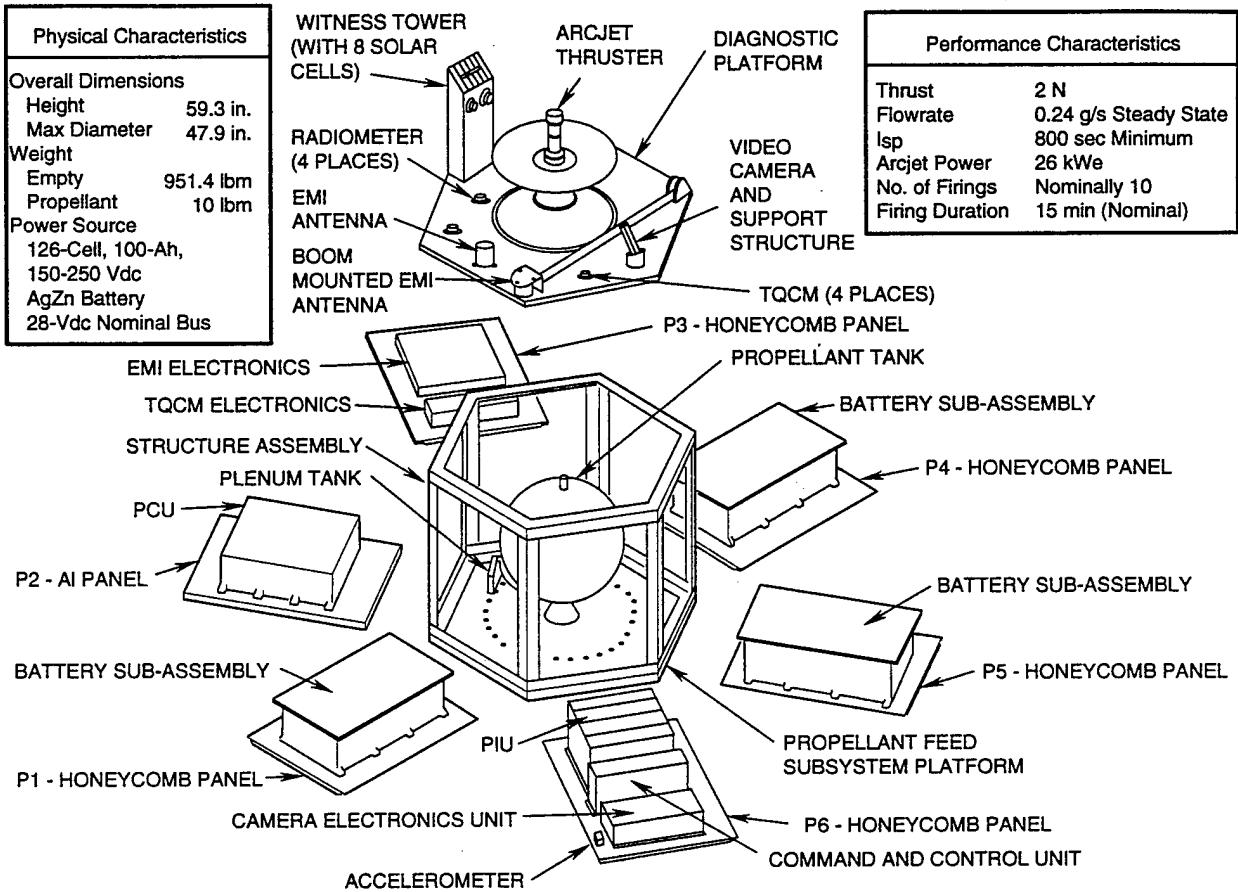

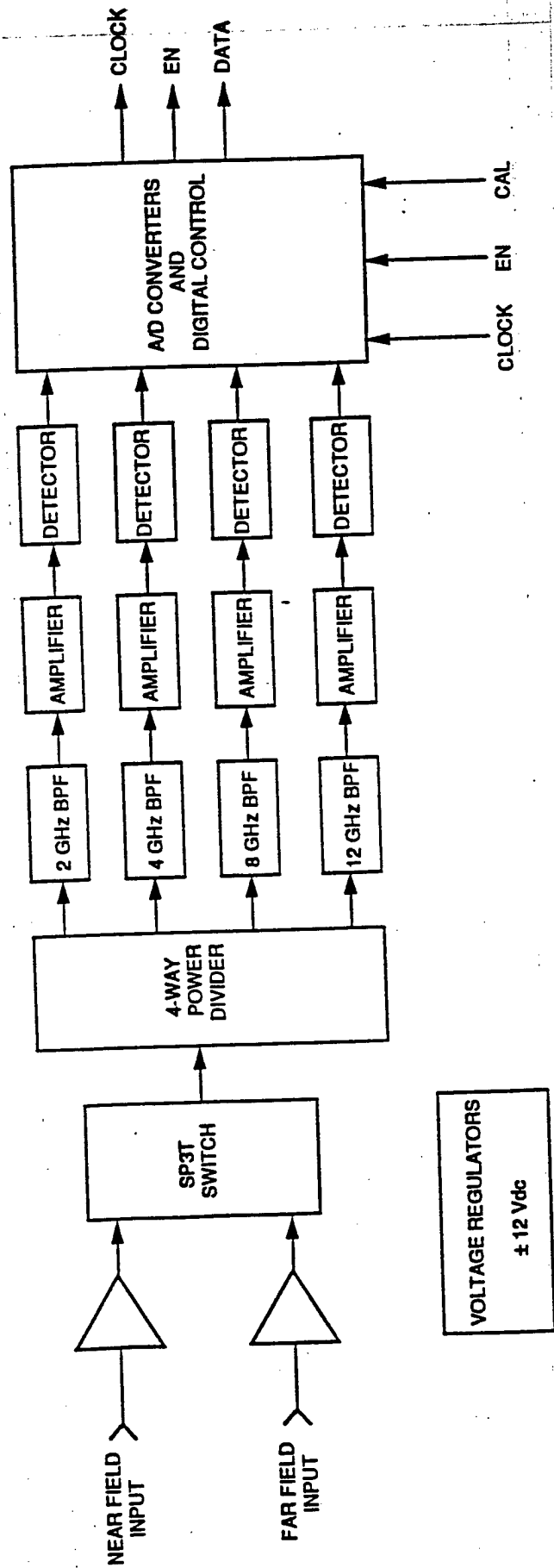

Fig. 2 - EMI experiment block diagram.

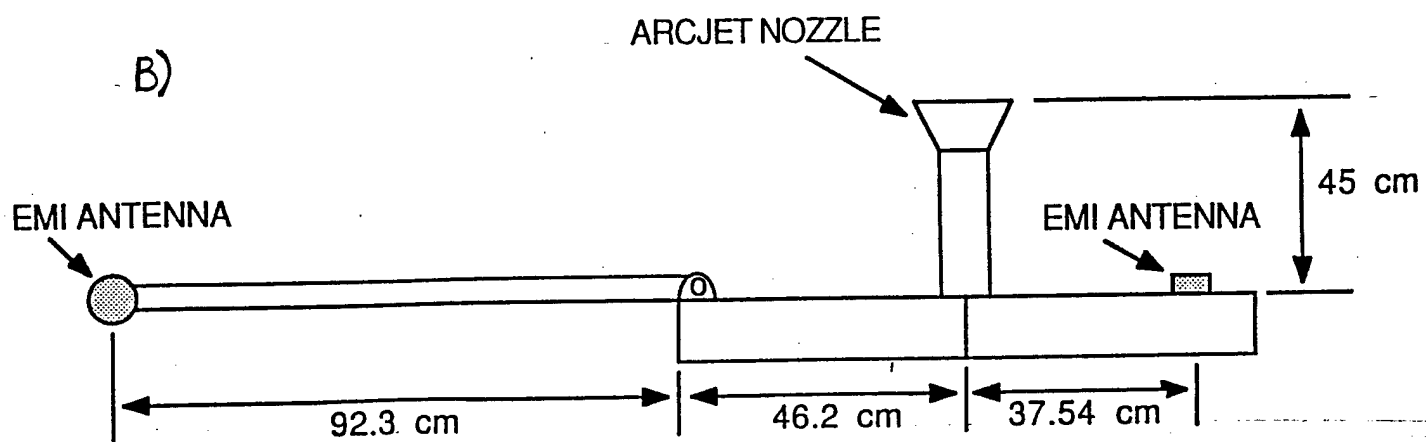
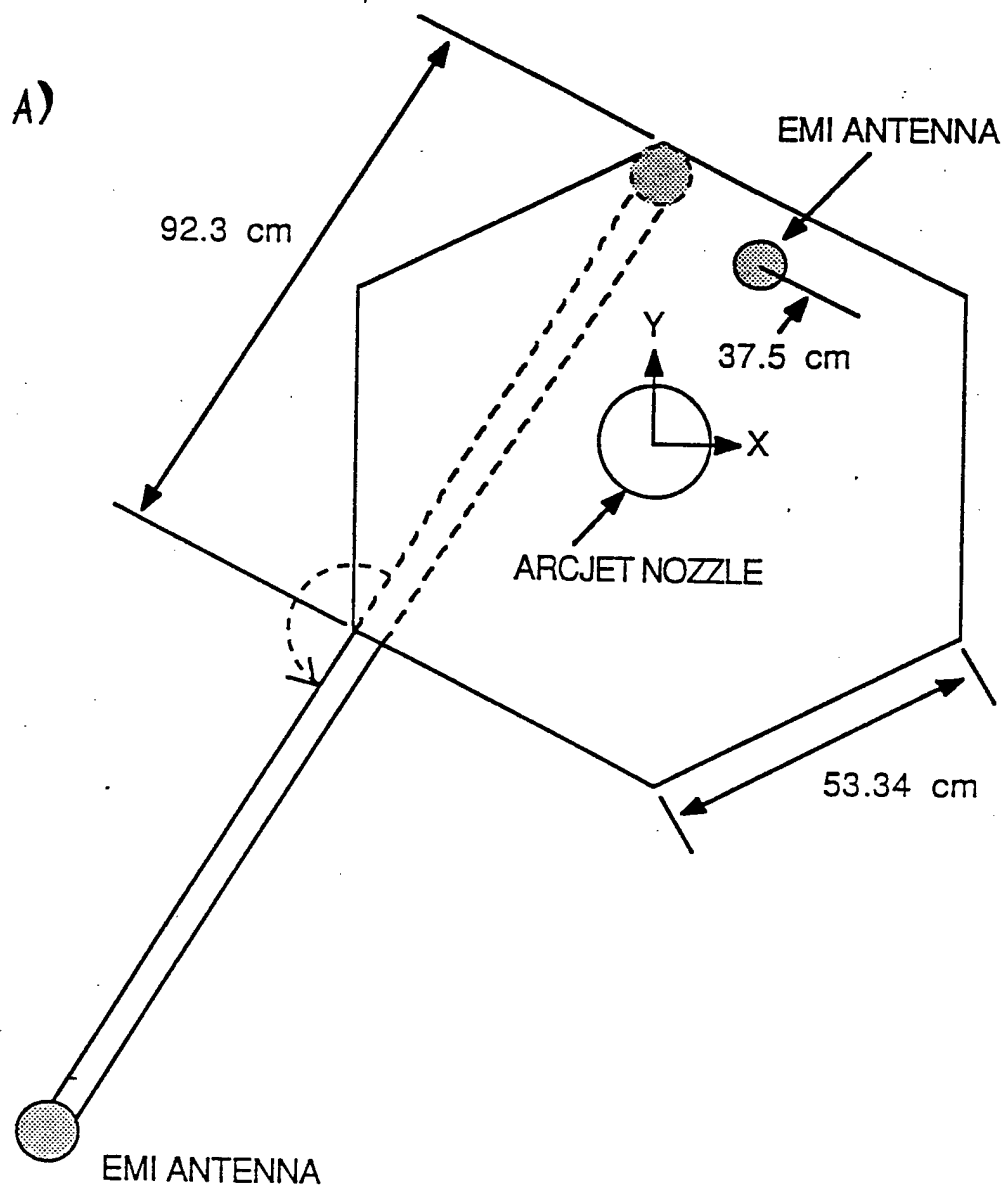

Fig. 3 - Figure 3 - Antenna Positions A) Side View; B) Top View.

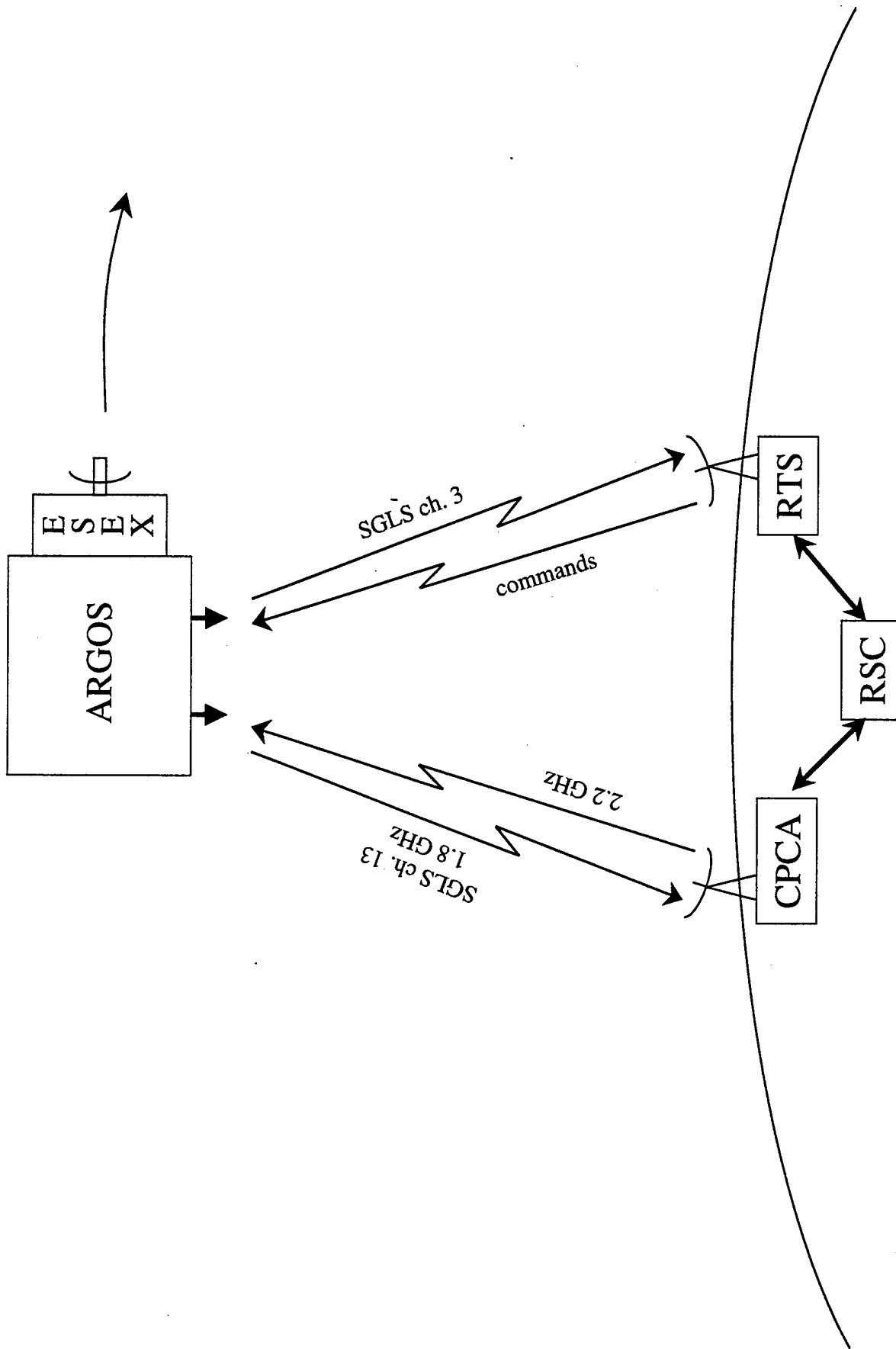

Fig 4

Deck Mounted Antenna; Arcjet Firing # 7

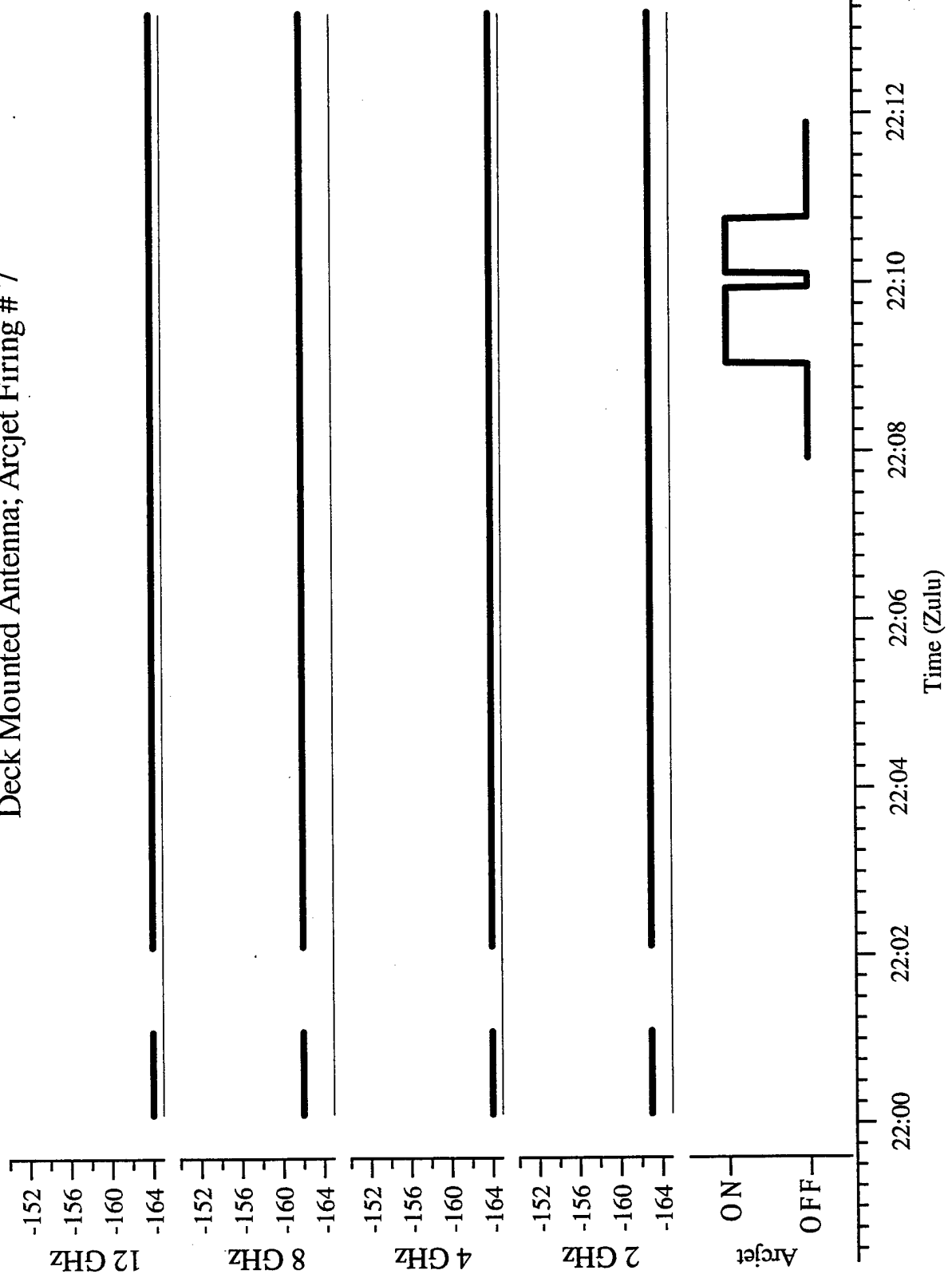

Fig. 5

Arcjet Firing # 2 and Baseline BER Curves

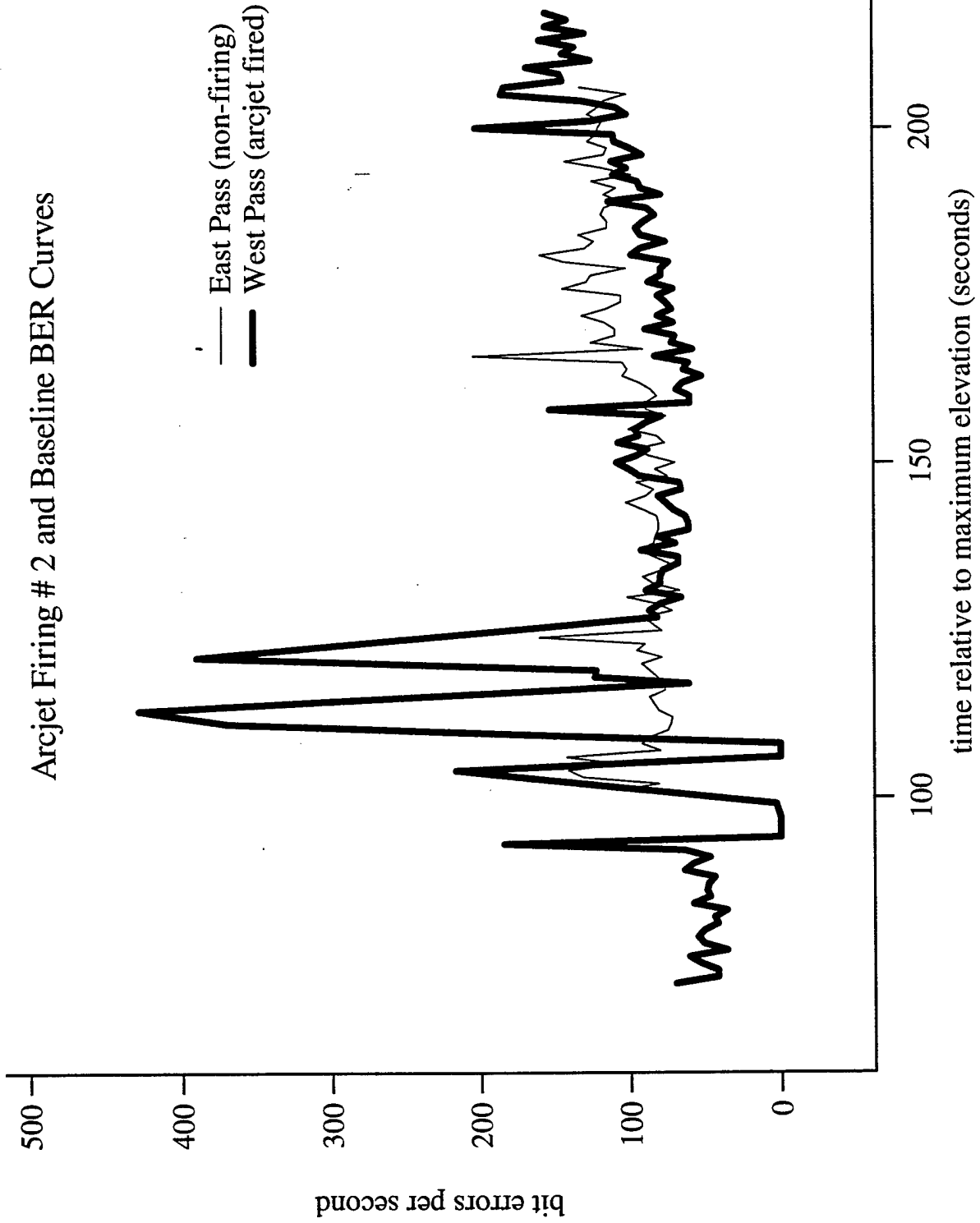

Fig. 6

Arcjet Firing #4 BER Curve with Arcjet Operation Indicated

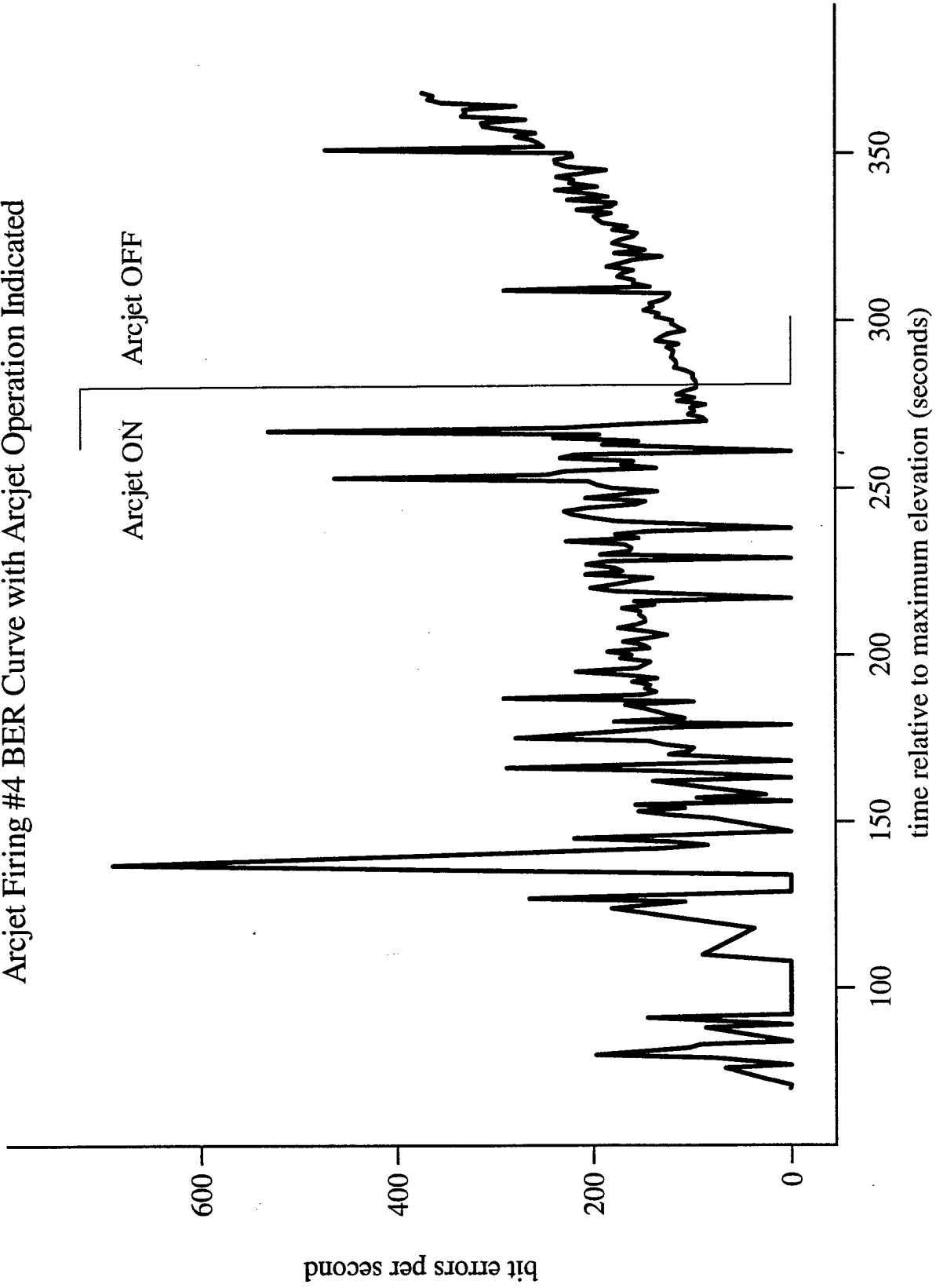

Fig. 7

Arcjet Firing #7 BER Curve with Arcjet Operation Indicated by Shaded Boxes

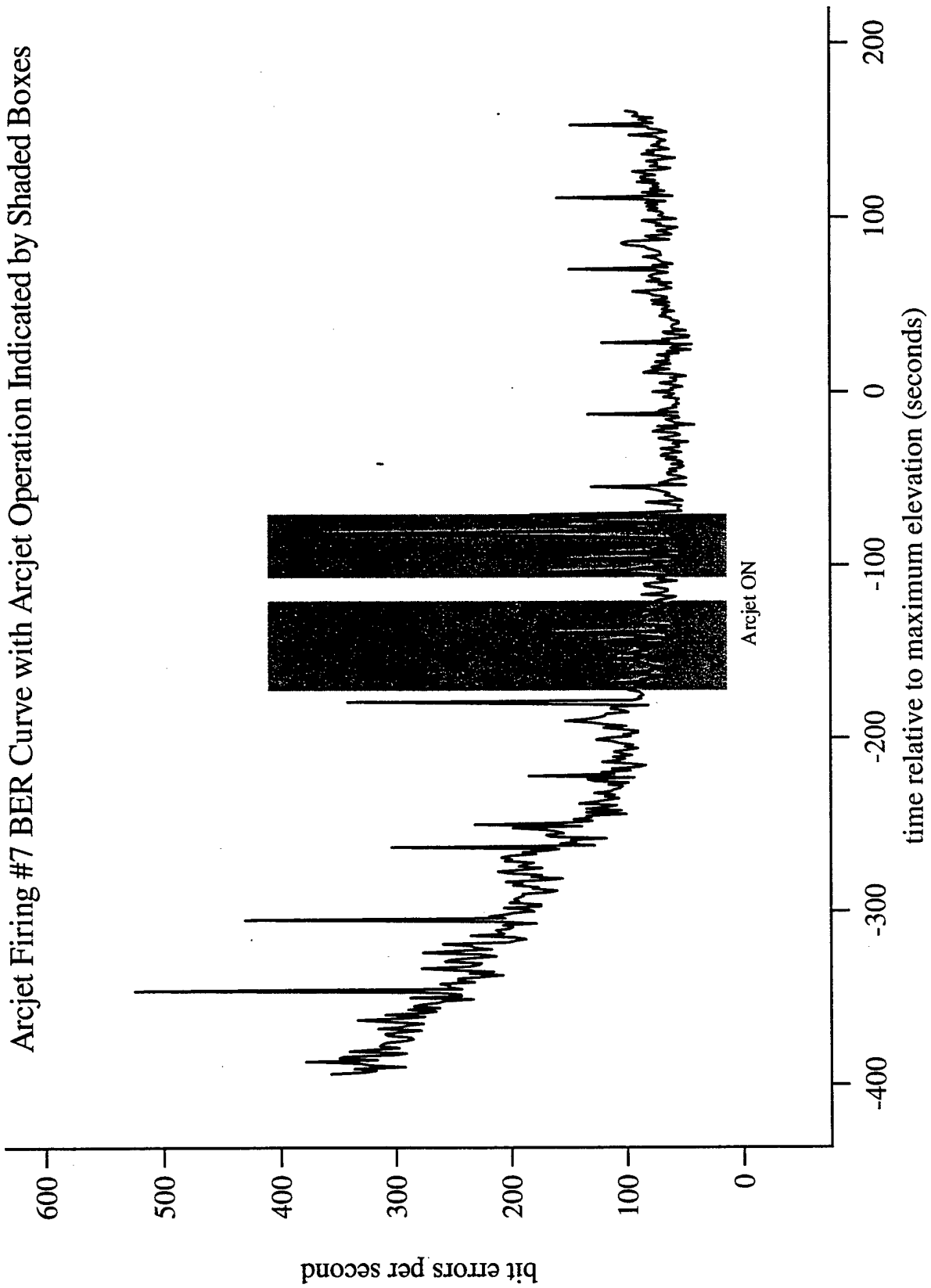

Fig. 8