

DES9641
MARCH 1997
ISSUE: 2

EXPERIMENTAL STUDY OF PARAMETERS INVOLVED
IN THE PROCESS OF THE GENERATION OF
MICROWAVE RADIATION BY COMPRESSION OF
IONIC CRYSTALS

EOARD contract F61708-96-W0312

SR-96-4081

DISTRIBUTION STATEMENT A
Approved for Public Release
Distribution Unlimited

Matra BAe Dynamics

20020927 108

AQ F02-12-3354

REPORT DOCUMENTATION PAGE

Form Approved OMB No. 0704-0188

Public reporting burden for this collection of information is estimated to average 1 hour per response, including the time for reviewing instructions, searching existing data sources, gathering and maintaining the data needed, and completing and reviewing the collection of information. Send comments regarding this burden estimate or any other aspect of this collection of information, including suggestions for reducing the burden, to Department of Defense, Washington Headquarters Services, Directorate for Information Operations and Reports (0704-0188), 1215 Jefferson Davis Highway, Suite 1204, Arlington, VA 22202-4302. Respondents should be aware that notwithstanding any other provision of law, no person shall be subject to any penalty for failing to comply with a collection of information if it does not display a currently valid OMB control number.
PLEASE DO NOT RETURN YOUR FORM TO THE ABOVE ADDRESS.

1. REPORT DATE (DD-MM-YYYY) 03-1997	2. REPORT TYPE Final Report	3. DATES COVERED (From - To) 11 September 1996 - 21-Apr-97
---	---------------------------------------	--

4. TITLE AND SUBTITLE Experimental Study Of Parameters Involved In The Process Of The Generation Of Microwave Radiation By Compression Of Ionic Crystals	<table border="1" style="width:100%"> <tr> <td>5a. CONTRACT NUMBER F6170896W0312</td> </tr> <tr> <td>5b. GRANT NUMBER</td> </tr> <tr> <td>5c. PROGRAM ELEMENT NUMBER</td> </tr> </table>	5a. CONTRACT NUMBER F6170896W0312	5b. GRANT NUMBER	5c. PROGRAM ELEMENT NUMBER
5a. CONTRACT NUMBER F6170896W0312				
5b. GRANT NUMBER				
5c. PROGRAM ELEMENT NUMBER				

6. AUTHOR(S) Dr. David Morgan	<table border="1" style="width:100%"> <tr> <td>5d. PROJECT NUMBER</td> </tr> <tr> <td>5d. TASK NUMBER</td> </tr> <tr> <td>5e. WORK UNIT NUMBER</td> </tr> </table>	5d. PROJECT NUMBER	5d. TASK NUMBER	5e. WORK UNIT NUMBER
5d. PROJECT NUMBER				
5d. TASK NUMBER				
5e. WORK UNIT NUMBER				

7. PERFORMING ORGANIZATION NAME(S) AND ADDRESS(ES) British Aerospace PLC FPC 500 Filton Filton, Bristol BS12 7QW United Kingdom	8. PERFORMING ORGANIZATION REPORT NUMBER N/A
---	--

9. SPONSORING/MONITORING AGENCY NAME(S) AND ADDRESS(ES) EOARD PSC 802 BOX 14 FPO 09499-0014	<table border="1" style="width:100%"> <tr> <td>10. SPONSOR/MONITOR'S ACRONYM(S)</td> </tr> <tr> <td>11. SPONSOR/MONITOR'S REPORT NUMBER(S) SPC 96-4081</td> </tr> </table>	10. SPONSOR/MONITOR'S ACRONYM(S)	11. SPONSOR/MONITOR'S REPORT NUMBER(S) SPC 96-4081
10. SPONSOR/MONITOR'S ACRONYM(S)			
11. SPONSOR/MONITOR'S REPORT NUMBER(S) SPC 96-4081			

12. DISTRIBUTION/AVAILABILITY STATEMENT
Approved for public release; distribution is unlimited.

13. SUPPLEMENTARY NOTES

14. ABSTRACT

This report results from a contract tasking British Aerospace PLC as follows: The contractor will perform a service consisting of experimental study of parameters involved in the process of the generation of microwave radiation by compression of ionic crystals as described in his proposal.

15. SUBJECT TERMS
EOARD, Electronic Devices, Physics

16. SECURITY CLASSIFICATION OF:			17. LIMITATION OF ABSTRACT UL	18. NUMBER OF PAGES 25	19a. NAME OF RESPONSIBLE PERSON Ingrid Wysong
a. REPORT UNCLAS	b. ABSTRACT UNCLAS	c. THIS PAGE UNCLAS			19b. TELEPHONE NUMBER (Include area code) +44 (0)20 7514 4285

EXPERIMENTAL STUDY OF PARAMETERS INVOLVED IN
THE PROCESS OF THE GENERATION OF MICROWAVE
RADIATION BY COMPRESSION OF IONIC CRYSTALS

EOARD contract F61708-96-W0312

Prepared by:

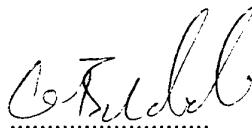
.....
Dr. C Budd

Approved by:

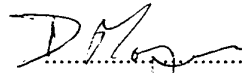
.....
Dr. D Morgan

Authorised by:

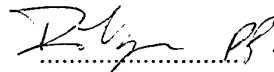
.....
M E Grainger

AMENDMENT RECORD SHEET

Issue No.	Date	Incorporated By	Comments
1	7/2/97	C. Budd	Original
2	14/3/97	C. Budd	Amended in the light of customer comments

CONTENTS

SECTION 1	INTRODUCTION
SECTION 2	PROPERTIES OF CSI
SECTION 3	MEASUREMENT TECHNIQUES
APPENDIX A	RELEVANT CAPABILITIES AND EXPERIENCE WITHIN THE CAVENDISH LABORATORY
APPENDIX B	EXPLANATORY NOTES
FIGURES	
REFERENCES	
DISTRIBUTION	

1 INTRODUCTION

This report provides an overview of previous work and established experimental methods to determine certain parameters of caesium iodide under conditions of shock compression. The parameters of principal interest are those which determine the equation of state and those which determine the relationship between pressure and electrical conductivity. The pressure regime it is proposed to address is that extending from atmospheric pressure to about one Mbar.

Section 2 of this report gives a brief overview of current knowledge of the properties of CsI at extreme pressures, while section 3 discusses appropriate measurement techniques.

The majority of the text in this report is taken directly from two reports prepared by the Cavendish Laboratory under contract to Matra BAe Dynamics:

Proud, W. G. and Bourne, N. K., Caesium Iodide: Structure And Properties Under Static And Shock Conditions, Cavendish Laboratory report PCS/SP1032, September 1996.

Bourne, N. K., High Pressure Equation-Of-State Data And Shock Conductivity Measurements Upon Caesium Iodide, Cavendish Laboratory report PCS/SP1033, September 1996.

Appendix A gives a summary of relevant capabilities at the Cavendish Laboratory.

Appendix B contains answers to several questions posed by EOARD in response to a draft copy of this report. The answers serve to provide further detail of a few key aspects of the capabilities described in the main body of the report.

2 PROPERTIES OF CSI

2.1 AMBIENT CONDITIONS

Caesium iodide at room temperature and pressure has a body-centred cubic (bcc) arrangement, a structure it shares with other Caesium halides (except CsF). The melting point of the substance is 894 K ; low for an ionic material. It is amongst the most compressible of the alkali halides and due to the size of the ions involved displays a very low charge separation.

These properties are not unexpected for this material as they follow the general trend down the alkali metal column of the periodic table.

The ionic radius of caesium is 0.169 nm, while that of iodine is 0.216 nm : a radius ratio of 0.782. A ratio of 0.732 would, from simple theory, predict a bcc structure while a ratio of 0.414 would favour a face centred cubic (fcc) structure. At temperatures less than 160 K a tetragonal structure has been found.

Thermodynamic parameters such as the enthalpy of formation, heat capacity and enthalpy of melting have been empirically obtained [1]. This work was driven by concerns over caesium iodide in nuclear reactors. Other workers [2] measured the same quantities and gave values in good agreement, however, they find a slight deviation in the heat capacity above 400 K which they ascribe to vacancy formation in the crystal. The formation of vacancies is regarded as not proven by Cordfunke [2] based on other workers' previously reported observations.

The mechanical properties at low rates of strain over a range of temperatures including room temperature have been published [3]. These show that CsI can show complex viscous flow properties and at high temperatures mechanisms such as kink formation and cation vacancy motion are found[3]. Kink formation and relaxation has received close attention [4].

In general, samples of CsI have a thallium dopant added as this causes the crystal to act as an X-ray sensitive scintillator emitting light in the visible region. Undoped [5] [6] and sodium-doped crystals are also used for this purpose. This scintillation mechanism occurs at 4.1 eV and is the result of a trapped exciton mechanism. The rotational (microwave)[7] and infra-red [8] spectra have been obtained and widely studied.

2.2 STATIC HIGH-PRESSURE CONDITIONS

Static high pressure studies have been performed using diamond anvil cells in which pressures of several hundred kbar are easily produced on very small volume samples (tens to hundreds of microns across). Caesium iodide has been studied due to its high compressibility and the assumption that the effects seen in CsI at low pressures would be seen in other alkali halides at higher pressures.

Several phase transitions have been found for CsI though the nature and number of these transitions remains controversial. A cubic to tetragonal transition [9,10] (amongst others) at 400 kbar and an orthorhombic one at around 560 kbar [11] and finally a hcp structure at 1500 - 2000 kbar represents a summary of all transitions reported. The tetragonal transition is widely accepted as occurring, though some [9,10] suggest it is better described as mildly orthorhombic. The high pressure orthorhombic transition is less widely reported and many [14] have failed to detect its presence.

The main area of controversy, however, revolves around the work of Vohra et al. [12] who suggested that at a pressure of 650 kbars the band gap of CsI would close and the material would become metallic. This was supported by Asuami [13]. They also accept a report of an orthorhombic structure in the pressure region of 650 kbars [14]. This provoked a response from Jeanloz et al. who measured the band gap up to 930 kbar and found it to be 0.55 eV [15]. Experimental measurement of the band gap at lower pressures was also presented, the CsI is yellow at 350 kbar, reddens to become opaque at 530 kbar. Metallisation is predicted to occur in the range 930 - 1100 kbar. This value is also predicted from recent (1992) Russian experiments since early Russian work in this field only considered pressures up to 180 kbar [16]. Other Russian workers produced similar evidence using optical absorption studies of the band gap at pressures up to 600 kbar [17-19].

In an earlier paper Jeanloz and Knittle [20] give a brief outline of the structure found in CsI as the static pressure is increased. They state that at 400 kbar, distortion of the lattice takes place and a body-centred tetragonal structure is produced. This phase transition displays no marked volume change and no hysteresis and is classed as a second-order phase transition (in fact there is no change in the first three derivatives of the pressure-volume relationship). The amount of distortion increases continuously with pressure and is associated with a rapid narrowing of the band gap in the structure attributed to the removal of degeneracy and opening out of the orbital /band structure of the material. This effect is most easily observed in the distance between the second-nearest neighbours of the ions.

Russian workers have taken X-ray patterns of CsI under these pressure regimes (up to 550 kbar) to compare the compressibility of CsI with that of Xe [21]. In a diamond anvil cell they placed both CsI and Xe to allow direct comparison of the compression isotherms of these materials. At 350 - 400 kbars they find the tetragonal distortion again with no measurable volume change. The compression isotherms of Xe and CsI merge at 150 kbar and remain the same up until 550 kbar at least. This matching is assumed to result from the Cs and I in the material becoming less ionic with increasing pressure. In 1990 this Russian group had studied the effect of possible uniaxial strain in their cell apparatus [22]. Taking samples of both polycrystalline and single crystal materials they found that the tetragonal distortion was more pronounced with a single crystal and that many of the previous measurements on CsI may suffer from interpretational difficulties due to this result [22]. One piece of evidence, however, was that as the loading rate was increased, the pressure required to provoke the phase transition decreased. The Russian workers agree with Mao et al. [23] that at static pressures of 1500 - 2000 kbar a hcp type

structure will be produced. This links with shock studies that find the hcp type structure well below 1000 kbar.

In 1995 Nardelli et al. [24] [25] studied the various evidence for tetragonal and orthorhombic phases in CsI; in particular the phonons in the structures. They conclude that there is a competition between tetragonal and orthorhombic phase with the orthorhombic phase being stable in CsI. The cubic to tetragonal transition being active at a volume compression of 0.54 and the orthorhombic phase becoming active at a compression ratio of 0.64

Pattyn [26] used Mossbauer spectroscopy to study samples held in diamond anvil cells at pressures up to 120 kbar. The values are presented in terms of molar volume versus Gruneisen gamma and are compared with Xe. Again, a similar dependence is found at these high pressures.

Mao's static work [23] finds good agreement with shock studies (especially high pressure data). In this paper the exact structure of the phase transition proposed by other authors is questioned; the tetragonal distortion being assigned to a structure which is strictly orthorhombic but having cell parameters very similar to tetragonal, this orthorhombic nature of the transition becomes more noticeable with increased pressure. However at the highest pressure the X-ray diffraction pattern indicates a hcp type structure. The existence of this orthorhombic phase has not been unanimously accepted.

The material has a compressibility under static conditions very similar to that found under shock conditions [27]. This was explained as being due to either the CsI having a very low thermal expansion coefficient or to another effect taking place to decrease the volume occupied under shock conditions. Williams [28] took samples of CsI in a diamond anvil cell and laser heated them to 6000 K; upon leaving the samples to cool both blue and purple stains were noticed. The blue was interpreted as colloidal alkali metal in the sample and the purple as patches of iodine. The electrical resistivity of the sample decreased by a factor of three compared with CsI held at the same pressure without heating. The structure of the caesium was taken to be the Cs(V) structure found at 480 kbar. The conclusion of this work was that in shock studies the elements occupied less volume than the compound. Thermodynamic calculation suggests that CsI is unstable to its elements above 650 kbar and 300 K, but the activation energy is high and shock conditions allow disproportionation to occur into caesium metal and iodine. Theoretical work on this problem suggests that at a high pressure there is no discernible charge separation between the "ions" and so the material is made up of electrically neutral material in which given time iodine species will form into iodine molecules leaving behind a caesium matrix forming a metal.

Linking theoretical and structural studies, Batsanov [29] calculated the charge separation of the ions in the structure. Assuming that when the van der Waals radii were equal to the covalent radii in the system no charge separation was present, he deduced that at a pressure of 650 kbar the materials were effectively uncharged. Calculations on other alkali halides shows that CsI has the lowest required pressure for this effect.

In conclusion, for the static high pressure work the most general conclusion would appear to be that at 400 kbar a weak first order or second order transition occurs which produces a structure which is very close to tetragonal in structure though is strictly orthorhombic. By pressures of 650 kbar the structure is best described as orthorhombic. If the applied pressure is above 150 kbar the compression isotherm is similar to that of Xe. Care must be taken in analysing data that no uniaxial stress is present in the experimental arrangement. At pressures of 650 kbar the Cs and I are uncharged in the material and if combined high pressure and a transient laser-induced heating is applied Cs and I may be observed to form in the metal. In relation to shock studies this may indicate that the similarity of the results of room-temperature isothermal and shock (with associated high temperature) compression is due to disproportionation of CsI in the shock studies.

2.3 SHOCK CONDITIONS

2.3.1 Shock temperature and equation of state

The most recent work on shocked CsI has been carried out at Lawrence Livermore by Ross and Rodgers [30-34]. In this they discuss the similarities between CsI and shocked Xe. It is interesting to link their work with the calculation of loss of charge separation calculated by the Russians and the suggested disproportionation of CsI in the static high pressure work.

Ross and co-workers [33] describe the structural changes from bcc to liquid as a continuous transition but are familiar with the high-pressure static work as they describe the possibility of a tetragonal structure as a point along the way towards the melted phase [34]. The assumption is made that the tetragonal phase is a meta-stable form which has a vanishingly small lifetime in the shock process.

At a shock-pressure of 250 kbar the CsI is described as being arranged as in a liquid noble gas [34]. There is reference made to their previous work on liquid and solid Xe [32]. Approximate temperatures are calculated from their models and a Hugoniot is presented.

Shock temperatures have been measured over the range of shock pressures of 240 - 920 kbar and temperatures in the range 3,400 - 10,800 K [31]. The temperature was calculated from high speed pyrometric studies of the light emitted from the front of the shock front. Six high speed photodiodes were used, each fitted with a filter to allow a limited degree of frequency dispersion (in the range 450 - 600 nm) to be measured and to ensure that a black /grey body fit was suitable. The response time of these photodiodes was 10^{-8} s whilst lattice-phonon relaxation times were assumed to be in the region 10^{-14} s so that the temperatures measured can be ascribed to a pseudo-equilibrium in the shock front. One area of uncertainty is that light will also be emitted from behind the shock front and by looking directly at the shock front the light seen will be a summation of the states in and behind the shock front modified by the opacity of the shocked material. Ross et al. address this difficulty by assuming that the materials behind the shock front is opaque.

The band gap of the solid is accepted to be 6.4 eV at STP ($1 \text{ eV} = 11,600 \text{ K}$) [31] [15]. This study aims to find the melting point as melting is easier to see in P,T space than P,V space in many cases. Melting starts at an estimated at 3500 K and 250 kbar. At 40% compression the liquid phase becomes significant (around 4000 K). A kink is seen in PV around 400 kbar (5000 K) at which point the electronic excitation is minimal. Above this pressure the band gap is around 1 eV and further energy goes into electronic excitation. Full metallisation is calculated to occur at 1 Mbar.

Ross et al. has published two papers [30, 33] dealing with the equation of state of the materials and the structure in the liquid phase and also a brief summary presented at conference [33]. Specific heat capacities are calculated based on Leonard-Jones -Devonshire potentials and assuming a soft sphere perturbation model. This model functions well until melting becomes significant. Nearest neighbour and radial distribution functions have also been presented by these authors.

Russian workers have also produced equation of state [35] and shock compressibility data on alkali halides in general [36].

2.3.2 Hugoniot

Marsh reports a Hugoniot for CsI in his standard text [37]. This can be compared with the Russian Hugoniot data published in 1963 [38] and Swenson's study [39]. Ross compares the experimental data with theoretical calculations in his 1984 paper amongst others.

2.3.3 Shock Conductivity

Shock conductivity measurements on CsI date from the late 1950's in the work of Christian and Alder [40]. They found with ionic and molecular materials a sharp increase in conductivity under the influence of shock waves. The bulk of the work of the 1950's and 60's is summarised in the review article by Styris and Duvall from the early 1970's [41]. In general, reviews have concentrated on American work in the field of phase transformations and devote only a few pages to shock conductivity studies. The main workers in this field are the Russians who have steadily produced several papers each year on this and related subjects. There is a lack of a concise review of their work, but Yakushev [42] has produced a review dealing solely with measurement techniques in the late 1970's. Since that date some further developments were made by Yakushev and also by Kuleshova and co-workers [43].

The mechanism of conductivity in ionic materials divides into two regions; a insulator-semiconductor transition in which both temperature and pressure have important effects and a high-pressure metallic region corresponding to closure of the band gap in which temperature is the predominant variable [41].

The conduction mechanism at low pressures is by a combination of vacancy diffusion, movement of defects, formation of dislocation and shear bands. Ionic conduction is strongly affected by pressure through the volume of activation. At high pressures the closure of the band gap in the region of the shock front increases the importance of the semiconduction/electronic contribution. This is less dependant on pressure but more so on temperature.

The separation of these terms has occupied much of the discussions in this field [41]. However, at high pressures (associated with melting) the conduction mechanism is completely dominated by electronic conduction. It is important to remember that other electrical effects may occur under the influence of a shock wave. In particular, a potential may be developed at the shock front.

2.3.4 Previous studies on CsI

American research on CsI was conducted in the mid-1960's and was not reported in the literature but resides in two reports quoted by Styris [41] and Graham and Duvall [50]. However, the review by Mineev et al [44] on shock polarisation of materials casts doubt over much of the conductivity work performed in the 1960s.

Kuleshova's 1981 paper [49] entitled "the conductivity of caesium iodide behind a shock wave between 10 and 100 kbar" would appear to cover the range of pressures required for study of CsI from atmospheric up to the shock-induced hcp phase. The paper gives a conductivity versus time graph for single crystal CsI, doped with Tl, and shocked to different points along the (111) direction or randomly orientated pure CsI. The paper does not state how the effects ascribed to the shock process were measured and contains no information on the shock profile applied to the system, the kinetics of conductivity change are not examined. In Kuleshova's previous paper [43], describing the measurement system, lack of reproducibility was considered an important factor in the analysis. However, this work represents a good first measurement of electrical conductivity in this system without the effect of shock polarisation.

3 MEASUREMENT TECHNIQUES

3.1 EQUATION OF STATE PARAMETERS

Techniques for the mechanical characterisation of materials under shock conditions are well established and thoroughly described in the literature.

For the purposes of the work described here, it is proposed to use two separate measurement configurations to cover different parts of the pressure range:

- (i) For measurements at pressures up to about 100 kbar, disc samples of CsI will have piezo-resistive gauges mounted on them. These samples will be struck by aluminium, copper or tungsten flyer plates travelling at velocities of up to at least 2 kms^{-1} . Velocity interferometry will be used to measure free surface velocity histories. The stress record from these experiments will be used to construct an accurate Hugoniot for the material. The shape of the pressure wave will reveal whether phase transition has occurred and the relative lengths of each part of the wave structure will be used to approximate the phase transition rate.
- (ii) In a separate configuration, the CsI disc will be mounted between two thick metal plates, either copper or tungsten. The function of the thick metal plates is to allow reverberation of the shock wave within the CsI and increase the total pressure experienced by the sample up to 1 Mbar. The isentrope will be constructed at pressures up to 1 Mbar.

3.2 CONDUCTIVITY

To measure the shock conductivity of an alkali halide requires several effects to be accounted for, such as the piezoelectric effect resulting in the production of a high voltage across the shock front. This effect is referred to as "shock polarisation" in the Russian literature and was recognised, at an early stage, as an effect which could mask conductivity measurement especially near the metallic conduction region.

The earliest published references to this effect are by Ivanov [45], Tyunyaev [46] and Linde [47] and show the effect of differing ionic ratios and shock pressure in affecting the shock polarisation. The effect was found to increase with increasing dielectric constant and an exhaustive account of shock polarisation effects is given in Mineev and Ivanov's review article [44].

Of direct relevance is the work of Tyunyaev et al. [48] who carried out impact loading experiments on single crystal CsI in three directions [100], [110] and [111] in pure and doped forms. Slip in CsI lattices occurs on {110} planes in the <100> directions: hence slip should easily occur in [110] and [111] directions hence the effect of dislocations on shock polarisations

can be studied using these three axes. Addition of Ba increases crystal strength whilst Pb has no effect. If dislocation movement is important then shock polarisation would be reduced in Ba-doped CsI compared with Pb-doped CsI. They conclude that below compression values of 1.25 dislocation motion is not important, at 1.4 compression and above dislocation motion may be significant but other point defect systems may be much more important.

Yakushev makes reference to this effect in his review and compares the different measurement systems for shock conductivity. These systems use shunts to measure the polarisation effect then use this in the analysis to remove the effect. Kuleshova [49] discusses an analytical method to overcoming this effect.

The above considerations suggest the experimental configuration shown in figure 1.

The shock wave sweeps two electrodes which are set within the CsI crystal. This has the effect of closing the switch and varying the resistor in the circuit on the left. The circuit is a constant current source for the time duration of the experiment and voltages are developed at S1 and S2 which are subtracted to remove the polarisation signal in each branch. By this means the resistance across the electrodes is measured. A calibration is then used to account for the sweeping of the electrodes by the shock and the corresponding increase in volume of conducting material.

The mechanical impedance match diagram of figure 2 indicates the Hugoniot for the tungsten and copper (potential flyer materials) and of CsI. The aim of this part of the investigation is to obtain conductivity data up to the point at which the band gap closes in the material. Above this point the material has infinite conductivity. This threshold is observed to be at 100 GPa for CsI. It will be seen that the velocity required to achieve such a stress with a tungsten flyer in a single shock experiment is of the order of 4.4 km s^{-1} . At the maximum operating velocity of the Cambridge facility the upper bound on the stress would be about 10 GPa whilst at Sowerby this may conceivably be increased to 30 GPa.

It is thus proposed to use a geometry which ramps up the stress in steps by sandwiching the crystal between tungsten anvils. By this means it will be seen that it is possible to achieve ca. 50 GPa in the Cambridge gun and 100 GPa in the Sowerby facility if they can achieve velocities of over 2.5 km s^{-1} . Since the gun will have to be modified and the performance thereby reduced, it remains to be seen whether this will be possible. A further caveat concerns the multiple shock nature of the experiment. By this means, conductivity is likely to be increased over that expected from a single pass experiment. It is hoped, however, to quantify this effect.

APPENDIX A
RELEVANT CAPABILITIES AND EXPERIENCE WITHIN THE
CAVENDISH LABORATORY

A.1 INTRODUCTION

Over the past 4 years a pool of staff and equipment has been built up which constitutes a unique UK research facility in the area of shock physics. This facility centres around a 50 mm laboratory gas-gun, designed and built within the department and commissioned in July 1992, and a second 75 mm gun. For microstructural analysis, a range of diamond cutting machines and polishing equipment has been assembled and two Cavendish technical assistants have been on a training course to learn the specialist skills required for specimen preparation. The resources of the Microstructural Physics group of the laboratory and their range of electron microscopes allows detailed examination of shocked samples. The personnel are a multidisciplinary team comprising physicists, a physical chemist and a material scientist reflecting the wide range of fields encompassed by the work. The facility is serviced by a full-time instrument-maker who builds fixtures for the experiments and keeps the gun and its attendant compressors and vacuum systems operational.

The shock wave process enables us to attain high-pressure transient thermodynamic states which must be studied within the few microseconds for which they exist. To this end state-of-the-art ultra high-speed apparatus is required. Three classes of measurement are at present routinely conducted. The first uses the Cavendish's unique range of high-speed cameras capable of achieving rates of up to 20 million frames per second, allowing the shock processes to be studied on the time-scales at which they occur. Coupled with this, multiple head flash X-ray can be used to probe the interior of the material as it deforms. Piezoresistive stress or strain gauges, embedded within the material, follow the internal state as the waves sweep across them giving a quantitative history of a Lagrangian station within the material. The VISAR (velocity interferometer system for any reflector) gives sub-nanosecond deformation velocity information. Finally, recovered specimens, with precisely controlled loading histories, can be sectioned and examined using S and TEM to determine microstructural features introduced by the shock.

A GHz spectroscopic system allows spectra of emitted radiation to be recorded as a function of time to follow reaction pathways in energetic materials or fractoemission processes in inerts. The light is sampled by embedded optical fibre links into the system.

All of these measurements may be carried out at temperatures from liquid nitrogen to several hundreds of degrees Celsius allowing the internal energy of the material to be adjusted as a variable. The combined information thus collected allows a detailed picture to be built of the macro- and microscopic processes at work within the material and suggests high-pressure constitutive descriptions.

A.2 REVIEW OF PRESENT PROJECTS

The materials studied at present include examples from a wide range of classes; ceramics, metals, ionic crystals, glasses, polymers and composites. The testing ranges from studies of the

most fundamental thermodynamic descriptions of materials, to high velocity impact behaviour of a realistic projectile and target geometry.

Current research topics include:

- Glass
- Aluminas
- Advanced ceramics
- GFRPs
- Metals
- Dynamic phase transitions/shock-to-reaction
- Ballistic Impact
- Foams
- PVDF gauges
- Emulsion explosives
- Thermites

The research conducted with ceramics is largely confined to the behaviour of aluminas varying in alumina content from 85% to fully dense polycrystalline materials or single-crystal sapphire. Other materials investigated include titanium diboride, silicon carbide, aluminium nitride and various alumina/zirconia composites. The interest in these ceramics concerns the microstructural explanation for the compressive limit of these multiphase materials at high strain-rate and the application of these properties to practical problems such as armours, turbine blades or medical implants. We have shown that the grain size, glass content and porosity all affect the compressive strength and that this strength itself is strain-rate sensitive. This has profound implications for the presently used constitutive relations which do not include any of these physical effects. Additionally, the physical significance of the elastic limit has been shown to depend both on microfracture within the ceramic matrix as well as plasticity within the alumina grains. The range of behaviour observed can be explained by either or both of these effects dominating as alumina content is changed. The ballistic performance has been shown to correlate with the shear strength behaviour above the elastic limit, and thus it has become important to design experiments which probe the behaviour of material fragmented and compressed, and to deduce suitable material descriptions for modelling to progress. Evidence of

light emission picked up from both high-speed photography and gauges embedded within the material, gives an indication of the complex range of behaviours occurring within the shocked material.

The range of metals at present under study include FCC and BCC materials such as copper and iron or tantalum, and ultrahard steels. A variety of tests from ultrasonic to plate-impact have been developed to monitor the variation of the bulk and shear moduli with temperature over the range from liquid nitrogen to about 375⁰ C. By measuring the variation of the transverse stress with pressure it is also possible to investigate the shear hardening processes introduced by the shock wave. Of particular interest is the martensitic phase-transition in iron which is accessible with the present facility. Compressive and tensile strength and shear properties may be measured, as well as studying the kinetics of the transition itself. One of the most exciting of the current areas of work, revolves around the shock properties of glasses of varying structure. Open-structure glasses such as borosilicates collapse as they rearrange their silicon tetrahedra under shock loading. This response can be observed occurring in the stress gauge traces. More significantly, filled glasses such as soda-lime, are found to fail in compression losing shear strength, by a mechanism that is as yet not understood, behind a front called a 'failure wave'. Our facility has been the first to visualise this process occurring and we are present developing new experimental techniques to investigate the phenomena and account for the structural collapse. Several key papers have appeared recently from our group which have attracted world interest. Variations in the structure of the glass and the consequent effect upon the micromechanical response represent an exciting and fascinating area of research which will be pursued in the future. Whilst amorphous materials such as glass show viscous effects which are tractable, many polymers show extremely complex mechanical properties which are a result of the linked-chain microstructure. It is well known that strain-rate sensitivity presents a problem in producing a good constitutive description of polymers in shocked conditions. Additional complications arise when fibre reinforcement is added to give additional compressive and tensile strength adding anisotropy to the material response. It is a challenge to produce a good constitutive relation for such materials that can be used with some degree of certainty. These composites are now amongst the most economically and strategically important materials to understand since many industries (particularly the aerospace industry) are designing a new generation of structures based on their strength and low density.

The gun is also used for ballistic investigations. The present study is a joint experimental and theoretical project using the facility to observe the behaviour of rods of various materials in impact. In the first experiments, two cylinders of material are impacted one upon the other and the resulting deformations are studied with high-speed photography; an adaptation of the Taylor test. The dynamic recording of the deformation behaviour provides a sensitive measure of the high strain-rate constitutive model. The second ballistic test combines high-speed photography with gauges to study the penetration of plates by rods in oblique impact. High-speed photography using optical techniques such as schlieren and Moire is used to visualise the event. In both experiments recovered material can be examined microstructurally. The project will provide unique information on deformation and penetration behaviour of metals in impact.

Whilst the areas described above have directly addressed problems of material response to shock waves, our other research interests lie in more traditional areas of solid state physics asking questions relating to the nature of the shock wave itself and the effect that its presence has on the conductivity of a material, whether it breaks bonds in the material, or whether it can give enough translational energy to reactive molecules that chemical reaction may occur. It is possible to measure the change in conductivity across an ionic solid by embedding electrodes across or through the sample so that a shock front subsequently sweeps them. The generation of vacancies or the activation of defects gives rise to changes in conductivity which relate to the impulse (amplitude and pulse length) of the shock. Such experiments can give detailed information on the defect generation within the shock front. Our techniques also allow us to study structural pressure-induced phase changes. Both the dynamic forward and reverse transition pressures, and the change kinetics may be investigated as different impulses are applied to the material. Similar experiments may be conducted on amorphous solids but the results are then much more difficult to interpret due to the random nature of the interatomic potentials across a particular conduction path.

If reactive materials are used, chemical reaction can be induced which alters the thermodynamic state so that a new shock pressure is measured. Such information can be used to construct models describing the initiation of explosives. To determine which reaction pathways are favoured, spectroscopic measurements can be made with individual spectra captured every 10 ns. Individual spectral peaks can be followed in order to characterise the species produced within the reacting zone behind the shock. This equipment is at present on order and will be commissioned over the next year. The technique will also allow us to gain an accurate value for the temperature of the shocked material; a state variable that has previously not been accurately determined to within better than an order of magnitude. Whilst all of these measurements will be made on simple reactive molecules, we have the possibility of quantifying the effects of shear on the chemical systems and in particular in investigating the possibility that the combined effects of pressure and shear may produce very rapid energy release akin to detonation. Such an experiment is produced using an additional feature of the 75 mm gun.

A.3 EXPLOSIVE RESEARCH

The high-speed photographic facilities at the Cavendish stem largely from the need to gain data on explosive initiation and detonation. The early work of Bowden and Yoffe identified ignition as starting from so called hot spots created within the reactive material. Work still continues on the various mechanisms by which high-temperatures can be created within the explosive matrix. These include cavity collapse, friction and shear banding. The question of the critical size of hot spot required to cause ignition of the material is still a question of debate and a benchmark experimental program is planned. The next stage of the ignition process takes the burning explosive and accelerates this deflagration into a reactive shock wave which defines full detonation. This process has been observed but not completely explained, yet an understanding of this mechanism is vital for the safe handling and transport of explosives. Finally, the detonation process can be induced by the passage of a shock wave alone. The spectroscopic

studies into this phenomena have been mentioned above as have the experiments planned to study the effects of shear upon explosive performance. The group in PCS studying explosives is poised to make major advances in this area in the near future.

A.4 PERSONNEL

Professor J. E. Field FRS

Professor Field is currently deputy head of the Cavendish Laboratory and head of the PCS division. His own group (for which he gets funding) is composed of 30 people. Research interests are fracture, impact and erosion phenomena, shock physics, high strain-rate properties, reactivity of solids, explosives and high-speed photography. He has built up what is probably the best equipped high-speed camera facility at any university in the world. Recently, he and Dr. Bourne were funded to build the 1D plate impact facility. Professor Field has published two books, edited five others and has over 250 publications. He has supervised 52 students to PhD. He was made an FRS in 1994.

Dr. N. K. Bourne

Dr. Bourne is currently an EPSRC advanced fellow working at the Cavendish Laboratory. He obtained a first in Physics and Theoretical Physics from Cambridge in 1986. He was a research fellow for the Commission for the Exhibition of 1851. He heads a group of four post-graduate students and two post-doctoral workers. This core group is supplemented by overseas workers from a variety of countries including the US and Japan. The main research areas of the group include shock physics, fracto-emission, cavitation and lightning strike. He has published over 50 papers in the shock area and has written technical reports for ICI, AEA, DRA and Pilkingtons. He was responsible for the design, installation and commissioning of the 1D plate impact facility. He has continued interest in lightning studies with AEA Culham and haemodynamic flow in diseased arteries.

Dr. W. G. Proud

Dr. Proud was awarded a first in Chemistry from Newcastle in 1987 and a PhD (Newcastle) in electrochemical characterisation of doped polymer membranes in 1990. He spent a post-doctoral period in Barcelona on applications of impedance spectroscopy to corrosion and deposition systems. Dr. Proud entered the Cavendish in January 1994 and has worked with propellants and other energetic systems, measuring and modelling the enhancement brought about by high voltage plasma injection. He was recently awarded three years funding for studies of light emission from shocked materials. Current research areas include shock-induced electrical properties and fast spectroscopy of inert and reactive materials. Dr. Proud has 20 publications and reports.

APPENDIX B
EXPLANATORY NOTES

B.1 INTRODUCTION

This appendix contains answers to several questions posed by EOARD in response to a draft copy of this report. The answers serve to provide further detail of a few key aspects of the capabilities described in the main body of the report.

Question 1

The literature review is excellent, but some specific conclusions would have been helpful. For example, an explanation of how what will be done differs from that which has already been done and what new/alternative materials might produce useful output at lower pressures would be helpful.

Answer to question 1

One possible programme of measurements would differ from previous shock measurements on CsI in several ways, the most important of which is that shock conductivity measurements would be performed with proper regard to the need to avoid the effects of shock polarisation. Such tests would be in advance of those undertaken by Russian workers in that the effects of shock polarisation and the pressures induced would be measured accurately and simultaneously for the first time.

Question 2

Are there other substances we should be looking at besides CsI? What are they and what are their properties, if they have been measured?

Answer to question 2

Apart from the fact that it is a semiconductor, CsI is good for the present application because it is highly compressible and therefore shows a strong dependence of conductivity on pressure. Any alternative material, would need those two general characteristics. Our particular interest, however, is in CsI and doped CsI.

Question 3

Is it really possible to achieve one Mbar pressure? If so, for how long? Do these pressures and pulse durations adequately mimic those generated by the CSWS? Can other guns (techniques) in the UK or US be used?

Answer to question 3

A pressure of 1 Mbar is perfectly achievable, though only for about 1 μ s.

A programme of measurements based on the facilities described in this report would not cover the range of pressures encountered in the CSWS if the pressures predicted by Barmin and Melnik are correct. However, the results from that programme would greatly improve the basis on which the behaviour of the material at higher pressures may be estimated.

It has been pointed out that there are reliable reports in the literature that CsI is effectively metallic at pressures from about 1 Mbar upwards and that the dependence of conductivity on pressure should be weak thereafter. If this is so (and it would appear to be at odds with claims made by Barmin and Melnik) then there may be little value to measurements made at pressures above 1 Mbar.

Question 4

What dopants have been considered and what impact does doping the CsI have on the measurements?

Answer to question 4

Dopants have not been considered in detail. They might have two separate classes of benefits; modified conductivity behaviour and improved machinability. Any detailed answer to this question is conjecture without a plausible mechanism.

Question 5

What differences would we expect to see when we compare static versus dynamic pressures?

Answer to question 5

The behaviour of CsI under shock compression can be expected to be totally different from that under static compression. In particular, static compression will be isothermal (rather than adiabatic) and will allow time for ionic conduction to play a role. The literature review contains details of the experimental evidence for comparison between static and dynamic properties. The major differences are that the dynamic confinement and transient nature of the thermodynamic states makes all processes limited by kinetics which alters observable behaviours.

Question 6

What effect will the presence of a magnetic field have on the properties that will be measured?
Are the pressures at which you measure sufficient to compress the magnetic field to the requisite diameters?

Answer to question 6

The presence of a magnetic field would limit the diagnostics that could be used. We have not considered the problem of performing a direct experimental simulation of the device. Rather we have considered way to generate the data that would be needed as input into a theoretical model. It is already apparent that the value of any model rests almost entirely on accurate formulations for the equation of state and for the conductivity-temperature-pressure behaviour.

FIGURES

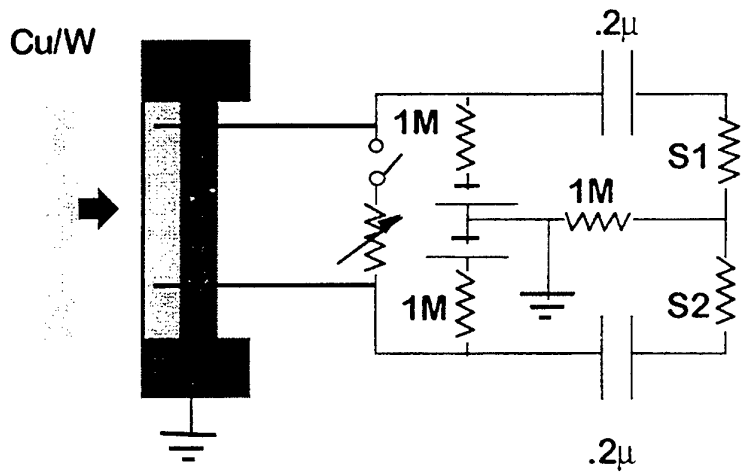

Figure 1
The proposed set-up for conductivity measurements

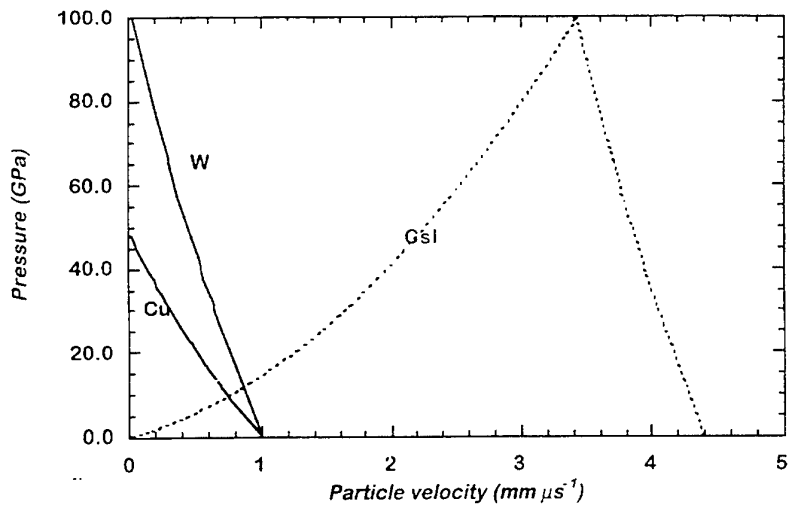

Figure 2
Impedance match diagram for copper, tungsten and CsI

REFERENCES

1. Takahashi, Y. and Kohsaka, Y., Heat capacity and enthalpy of CsI from 300 to 830 kJ, Nuclear Mat., volume 130, pages 109 - 114, 1985.
2. Cordfunke, E.H.P. and Prins, G., The thermochemical properties of CsI : I, Thermodynamic functions of solid CsI, Thermochem. Acta., volume 90, pages 169 - 176, 1985.
3. Urusovskaya, A.A. and Demchenko, V.V., Plastic deformation of CsI single crystals at high temperatures, Cryst. Res. Technol., volume 27, pages 1121 - 1131, 1992.
4. Petchenko, A.M. Relaxation processes in crystals of CsI under conditions of kink formation, Bull.Russ.Acad.Sci., volume 57, pages 1915 - 1917, 1993.
5. Nishimura, H., Sakata, M., Tsujimoto, T.T. and Nakayama, M., Origin of the 4.1 eV luminescence in pure CsI scintillator, Phys. Rev. B, volume 51, pages 2167 - 2172, 1995.
6. Kataev, S.G. and Chaldyshev, V.A., Interpretation of the spectra of ultrafast luminescence of cesium iodide based on the energy band spectrum, Phys. Solid State, volume 35, pages 1329 - 1332, 1993.
7. Rusk, J.R. and Gordy, W., Phys. Rev. page 817, 1962.
8. Braun, V., Guo, B., Zhang, K.-Q., Dulick, M., Bernath, P.F. and McRae, G.A., Infrared emission spectroscopy at 100 μ m Vibration rotation spectrum of CsI, Chem. Phys. Letts., volume 228, pages 633 - 640, 1994.
9. Christensen, N.E. and Satpathy, S., Pressure-induced Cubic to tetragonal Transition in CsI, Phys. Rev. Lett., volume 55, pages 600 - 603, 1985.
10. Huang, T.-L. and Ruoff, A.L., Equation of state and high-pressure transition of CsI Phys. Rev. B., volume 29, pages 1112 - 1114, 1984.
11. Satpathy, S., Christensen, N.E. and Jepson, O., etallisation of CsI under pressure : Theoretical results, Phys. Rev. B., volume 32, pages 6793 - 6799, 1985.
12. Vohra, Y.K., Duclos, S.J. and Ruoff, A.L., Instability of the CsCl structure in ionic solids at high pressures Phys. Rev. Lett., volume 54, pages 570 - 573, 1985.
13. Asaumi, K. and Kondo, Y., Effect of very high pressure on the optical absorption spectra in CsI, Solid State Comm., volume 40, pages 715 - 718, 1981.

14. Asaumi, K., Pressure induced successive phase transitions in CsI and its equation of state in relation to metallisation, *Phys. Rev. B*, volume 29, pages 1118 - 1120, 1984.
15. Williams, Q. and Jeanloz, R., Measurements of CsI band gap closure to 93 GPa, *Phys. Rev. Lett.*, volume 56, pages 163 - 164, 1986.
16. Popselov, Y.A. and Kusun, N.N., Problem of the metallisation of CsI under the action of pressure, *Sov. Phys. Solid State*, volume 8, pages 134 - 136, 1966.
17. Makarenko, I.N., Goncharov, A.F. and Stishov, S.M., Optical absorption spectra of CsI at pressures up to 60 GPa, *J. de Physique*, volume C8, pages 43 - 45, 1984.
18. Makarenko, I.N., Goncharov, A.F. and Stishov, S.M., Optical absorption spectra of CsI at pressures up to 60 GPa *Phys. Rev. B*, volume 29, pages 6018 - 6019, 1984.
19. Makarenko, I.N., Goncharov, A.F. and Stishov, S.M., Investigation of the Optical absorption spectra of CsI under pressures up to 60 GPa, *JETP*, volume 38, pages 545 - 548, 1984.
20. Knittle, E. and Jeanloz, R., Structural and bonding changes in CsI at high temperatures, *Science*, volume 223, pages 53 - 55, 1984.
21. Zisman, A.N., Aleksandrov, I.V. and Stishov, S.M., X-ray diffraction study of the equations of state of Xe and CsI at pressures up to 55 GPa, *JETP*, volume 40, pages 1029 - 1032, 1985.
22. Aleksandrov, I.V., Goncharov, A.F., Makarenko, I.N. and Stishov, S.M., New data on the equation of state for the phase transitions of cesium iodide, *JETP*, volume 70, pages 745 - 747, 1990.
23. Mao, H.K., Wu, Y., Hemley, R.J., Chen, L.C., Shu, J.F., Finger, L.W. and Cox, D.E., High-pressure phase transition and equation of state of CsI, *Phys. Rev. Letts.*, volume 64, pages 1749 - 1752, 1990.
24. Nardelli, M.B., Baroni, S. and Gianozzi, P., High-pressure low symmetry phases of caesium halides, *Phys. Rev. B*, volume 51, pages 8060 - 8068, 1995.
25. Baroni, S. and Gianozzi, P., Pressure induced structural instability of cesium halides from ab-initio pseudo-potential techniques, *Phys. Rev. B*, volume 35, pages 765 - 769, 1987.

26. Pattyn, H., Abd-Elmeguid, M.M., Bukshpan, S., Milants, K. and Verheyden, J., Pressure effects on electron charge densities and lattice dynamics in CsCl and CsI, *Phys. Rev. B*, volume 51, pages 10357 - 10363, 1995.
27. Vaidya, S.N. and Kennedy, G.C., Compressibility of 27 halides to 45 kbar, *J. Phys. Chem. Solids*, volume 32, pages 951-964, 1971.
28. Williams, Q. and Jeanloz, R., Pressure-induced disproportionation of CsI, *Phys. Rev. Letts.*, volume 59, pages 1132-1135, 1987.
29. Batsanov, S.S., Pressure dependance of bond polarities in crystalline materials, *Organic Materials*, volume 30, pages 1090 - 1096, 1994.
30. Aidun, J., Bukowinski, M.S.T. and Ross, M., Equation of state and metallisation of CsI, *Phys. Rev. B*, volume 29, pages 2611 - 2621, 1984.
31. Radousky, H.B., Ross, M., Mitchell, A.C. and Nellis, W.J., Shock temperatures and melting in CsI, *Phys. Rev. B*, volume 31, pages 1457-1462, 1985.
32. Ross, M. and McMahan, A.K., Condensed xenon at high pressure, *Phys. Rev. B*, volume 21, pages 1658-1664, 1980.
33. Ross, M. and Rogers, F.J., The structure of dense alkali halide melts, *J. de Physique*, volume C8, pages 229-233, 1984.
34. Ross, M. and Rogers, F.J., Structure of dense shock melted alkali halides : Evidence for a continuous pressure-induced structural transition in the melt, *Phys. Rev. B*, volume 31, pages 1463-1468, 1985.
35. Pavlovskii, M.N., Vaschenko, V.Y. and Simakov, G.V., Equation of state for caesium iodide, *Sov. Phys. Solid State*, volume 7, pages 972 - 974, 1965.
36. Kuzmenko, E.A., Shock compressibility and equations of state of alkali-halide metals, *Russ. Acad. Sci. High Temp.*, volume 30, pages 52 - 57, 1992.
37. Marsh, S.P., *LASL Hugoniot Data. 1980*, Berkley and Los Angeles: University of California Press.
38. Altshuler, V.L., Pavlovskii, M.N., Kuleshova, L.V. and Simakov, G.V., Investigation of alkali-metal halides at high pressures and temperatures produced by shock compression, *Sov. Phys. Solid State*, volume 5, pages 203 - 211, 1963.

39. Swenson, C.A., Shock wave overtake measurements on cesium iodide, in Shock Waves in Condensed Matter - 1985, Y.M. Gupta (Ed), Plenum, pages 135-144, 1986.
40. Alder, B.J. and Christian, R.H., Metallic transition in ionic and molecular crystals, Phys. Rev., volume 104, pages 550-551, 1956.
41. Styris, D.L. and Duvall, G.E., Electrical conductivity of materials under shock compression, High temp - High press 2 (1970), pages 477-499.
42. Yakushev, V.V., Electrical measurements in a dynamic experiment, Comb. Expl. Shock 14, pages 131-146, 1978.
43. Gatilov, L.A. and Kuleshova, L.V., Measurement of high electrical conductivity in shock compressed dielectrics, J. Appl. Mech. Tech. Phys., volume 1, pages 114 - 117, 1981.
44. Mineev, V.N. and Ivanov, A.G., Electromotive force produced by shock compression of a substance, Sov. Phys. Usp., volume 19, pages 400 - 419, 1976.
45. Ivanov, A.G., Lisitsyn, Y.V. and Novitskii, E.Z., Polarisation of dielectrics under shock load, Sov. Phys. JETP, volume 27, pages 153-155, 1968.
46. Tyunyaev, Y.I. and Mineev, V.N., Mechanism of shock wave induced polarisation of doped alkali halide crystals, Sov. Phys. Solid State, volume 15, pages 1269 - 1270, 1973.
47. Linde, R.K., Murri, W.J. and Doran, D.G., Shock-induced electrical polarisation of alkali halides, J. App. Phy. , volume 37, pages 2527 - 2532, 1966.
48. Tyunyaev, Y.N., Urusovskaya, A.A., Mineev, V.N. and Ivanov, A.G., Role of dislocations in impact polarisation of alkali-halide crystals, Sov. Phys. Solid State, volume 10, pages 2683-2688, 1969.
49. Gatilov, L.A. and Kuleshova, L.V., Electrical conductivity of CsI behind a shock-wave front at pressures up to 100 GPa, Sov. Phys. Solid State, volume 23, pages 1663 - 1665, 1981.
50. Davison, L. and Graham, R.A., Shock compression of solids, Phys. Repts., volume 55, pages 255-379, 1979.

DISTRIBUTION

Dr. Ira W. Merritt	CSSD-TC-AC, PO Box 1500, Huntsville, Alabama, 35807-3801, USA.	1 copy
Ms. Vicky Cox	European Office of Aerospace Research and Development, 223/231 Old Marylebone Road, London, NW1 5TH	1 copy
Mr. David Peebles	DIST DI51, Old War Office Building, Whitehall, London, SW1A 2EU	1 copy
Dr. David Morgan	FPC 500, BAe Dynamics, Filton	1 copy
Dr. Chris Budd	FPC 440, BAe Dynamics, Filton	1 copy