

AFOSR COATED CONDUCTOR REVIEW
Madison, WI, May 22-24, 2002

Critical Currents and AC Losses in Model YBCO Structures

M. Polak, L. Krempasky, E. Demencik
Institute of Electrical Engineering, Bratislava, Slovakia
Department of Electrodynamics of Superconductors

in collaboration with

B. Moenter, S. Kreiskott, D. Wehler
University of Wuppertal, Germany

Bratislava, May 2002

REPORT DOCUMENTATION PAGE

Form Approved OMB No. 0704-0188

Public reporting burden for this collection of information is estimated to average 1 hour per response, including the time for reviewing instructions, searching existing data sources, gathering and maintaining the data needed, and completing and reviewing the collection of information. Send comments regarding this burden estimate or any other aspect of this collection of information, including suggestions for reducing the burden, to Department of Defense, Washington Headquarters Services, Directorate for Information Operations and Reports (0704-0188), 1215 Jefferson Davis Highway, Suite 1204, Arlington, VA 22202-4302. Respondents should be aware that notwithstanding any other provision of law, no person shall be subject to any penalty for failing to comply with a collection of information if it does not display a currently valid OMB control number.

PLEASE DO NOT RETURN YOUR FORM TO THE ABOVE ADDRESS.

1. REPORT DATE (DD-MM-YYYY) 25-07-2002			2. REPORT TYPE Final Report		3. DATES COVERED (From - To) 19 April 2001 - 29-Aug-02	
4. TITLE AND SUBTITLE AC Loss Minimization in High Temperature Superconductors - Slovakia				5a. CONTRACT NUMBER F61775-01-WE027		
				5b. GRANT NUMBER		
				5c. PROGRAM ELEMENT NUMBER		
6. AUTHOR(S) Dr. Milan Polak				5d. PROJECT NUMBER		
				5d. TASK NUMBER		
				5e. WORK UNIT NUMBER		
7. PERFORMING ORGANIZATION NAME(S) AND ADDRESS(ES) Institute of Electrical Engineering Dubravska 9 Bratislava 84239 Slovak Republic				8. PERFORMING ORGANIZATION REPORT NUMBER N/A		
9. SPONSORING/MONITORING AGENCY NAME(S) AND ADDRESS(ES) EOARD PSC 802 BOX 14 FPO 09499-0014				10. SPONSOR/MONITOR'S ACRONYM(S)		
				11. SPONSOR/MONITOR'S REPORT NUMBER(S) SPC 01-4027		
12. DISTRIBUTION/AVAILABILITY STATEMENT Approved for public release; distribution is unlimited.						
13. SUPPLEMENTARY NOTES						
14. ABSTRACT This report results from a contract tasking Institute of Electrical Engineering as follows: The contractor will investigate yttrium-barium-copper oxide (YBCO) coatings divided into filaments with various widths and separations. AC loss measurements as well as magnetization measurements will be conducted using a Hall Probe magnetometer. Experimental results will then be compared with the theoretical models and predictions by the United Kingdom research group (SPC 014028).						
15. SUBJECT TERMS EOARD, Aircraft Subsystem, Power, Superconductivity						
16. SECURITY CLASSIFICATION OF:			17. LIMITATION OF ABSTRACT UL	18, NUMBER OF PAGES 28	19a. NAME OF RESPONSIBLE PERSON David M. Burns, Lt Col, USAF	
a. REPORT UNCLAS	b. ABSTRACT UNCLAS	c. THIS PAGE UNCLAS			19b. TELEPHONE NUMBER (Include area code) +44 (0)20 7514 4955	

Motivation of our studies

- Reduction of hysteresis loss in YBCO based AC tapes → fine filamentary structure
 - Is there a limit for the filament width, below which filament J_c degrades? (A possible limitation due to finite dimensions of grain boundaries: A. M. Campbell, AFOSR Program Review, Stanford, October 2001 [1])
 - Which is the hysteresis loss in narrow YBCO filaments?
on LaAlO_3 substrate
on Ni substrate
- Understanding of coupling current behavior in YBCO filamentary tapes
 - How an AC conductor should look like?

Layout

1. Samples

YBCO rings with various filament width

YBCO tapes with filamentary structure

2. Measurements of I_c and hysteresis losses in rings at 77K

Method

Apparatus

Results

3. Measurements of B_z at elevated frequencies (up to 500 Hz)

4. Parameters affecting coupling currents and transverse resistivity

Possible arrangement of filaments and metall layer

Boundary resistivity YBCO/metal, r_b

4. Conclusions

Samples

Ring samples YBCO on LaAlO (Microphotographs of the rings see Fig.1):

mean ring diameter $D_0 = 3 \text{ mm}$
width: $2w_f = 300 \text{ microns}$
101 microns
51 microns
21 microns

Ring samples YBCO on Ni

mean ring diameter $D_0 = 3 \text{ mm}$
width: $2w_f = 300 \text{ microns}$
97 microns
50 microns
22 microns

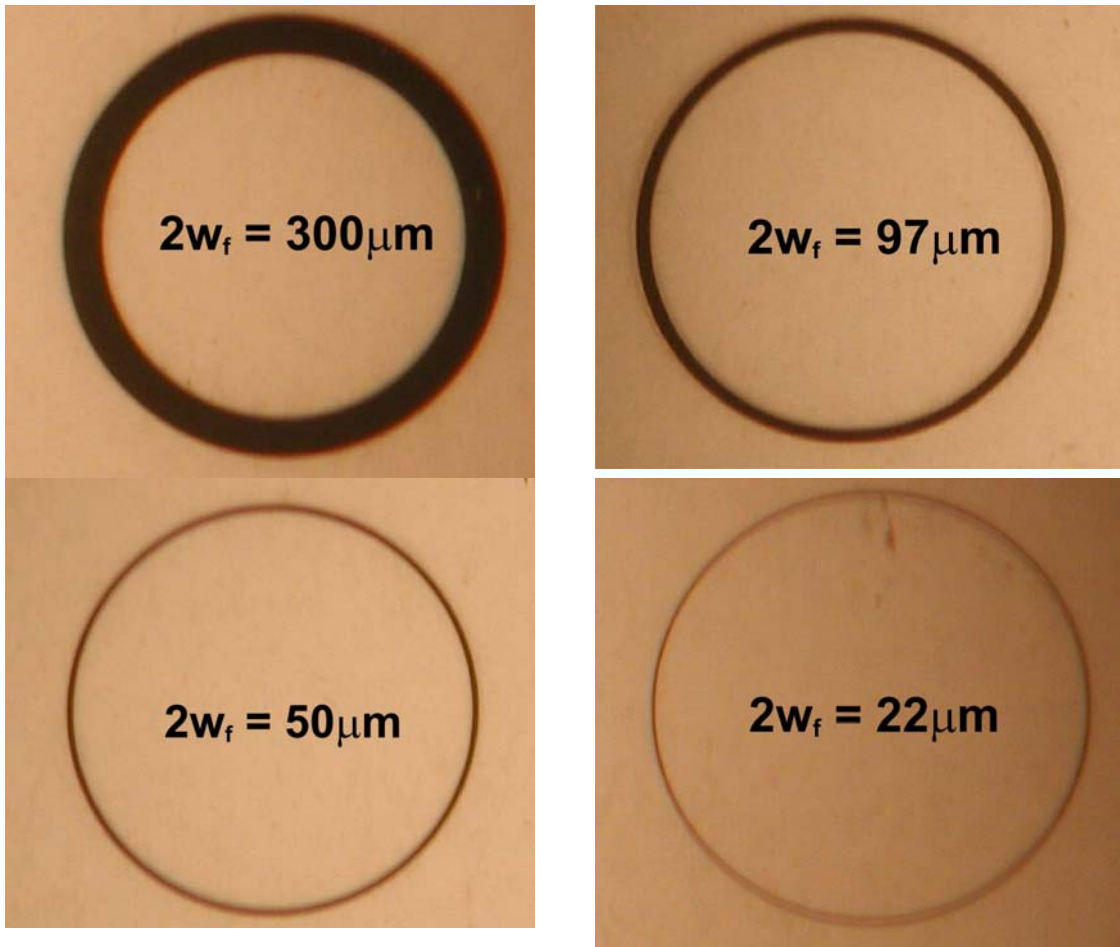

Fig. 1 YBCO rings

Untwisted filamentary tape samples (Microphotographs see Fig.2):

20 x 0.26 mm wide filaments, gap 0.04 mm (total width 6.0 mm)

40 x 0.13 mm wide filaments, gap 0.02 mm (total width 6.0 mm)

80 x 0.065 mm wide filaments, gap 0.01 mm (total width 6.0 mm)

20 x 260 μm

40 x 130 μm

80 x 65 μm



Fig. 2 YBCO filaments

Measurements of B_z vs B_e for rings, determination of E-I curves and I_c

The measuring method is described in [2].

The sample has a form of a ring with the mean ring radius R_0 (diameter D_0), the thickness d and the width of the current path $2w_f$

Measurement of current I:

- An external magnetic field B_e induces a current I in the ring
- this current creates magnetic field B_s ,
- B_s is measured by a Hall Probe (HP)

The value of B_s on the ring axis in the distance z from the ring is

$$B_s(r=0, z) = (\mu_0 I R_0^2 / 2) (R_0^2 + z^2)^{3/2} \quad (1)$$

→ I is calculated from B_s from Eq.(1)

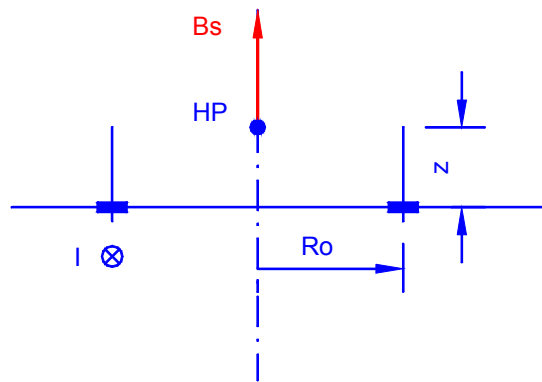

Fig. 3

Determination of E – dynamic regime

The rate of change of the external magnetic field, dB_e/dt , governs the electric field in the ring:

$$E = (R_0/2) dB_e/dt \quad (2)$$

- Measuring B_s as a function of B_e at various $dB_e / dt = \text{const.}$ we obtain a family of hysteresis loops
- E is determined from Eq (2)

Determination of E – static regime

In this case the electric field is governed by the decay of the induced current dI/dt

$$E = (1/2\pi R_0) L_{\text{ring}} dI/dt \quad (3)$$

E is in this case much smaller than E in dynamic experiments (by several orders of magnitude)

In experiments we measured I several minutes after induction of the ring current

Hysteresis losses in YBCO rings and filaments with different width

→ Hysteresis losses are determined from the hysteresis loops $M \sim B_s$ measured as a function of B_e

Loss per cycle in a ring $A_{h,\text{ring}} = \int_{-B_e}^{B_e} M dB_e \quad [\text{J}]$

→ M axis calibration is based on the knowledge of I_c using Equations (there is a difference between M_{ring} and $M_{\text{fil},1\text{m}}$):

Magnetic moment of the ring $M_{\text{ring}} = I_c \pi D_0^2 / 4 \quad [\text{Am}^2]$

Critical current in the ring $I_c = M_{\text{ring}} 4 / (\pi D_0^2)$

Magnetic moment of the filament per unit length

$$M_{\text{fil},1\text{m}} = I_c w_f / 2 = M_{\text{ring}} 2w_f / (\pi D_0^2)$$

The ratio of magnetic moments of the filament per unit length and of the ring is:

$$M_{\text{fil},1\text{m}} / M_{\text{ring}} = 2w_f / (\pi D_0^2)$$

Experimental set-up

Low frequency measurements at 77 K (from 1 mHz up to 100 mHz)

Main parts:

- Cu magnet producing external fields up to 0.4 T with f up to ~ 100 mHz, supplied by a bipolar power supply
- Hall Probe with the active area of $\sim 0.05 \times 0.05$ mm and sensitivity of about $15 \mu\text{V}/\text{Gauss}$
- coordinate system for the Hall probe movement x, y, z

Photo (Fig. 4) shows the disassembled system for low frequency experiments.

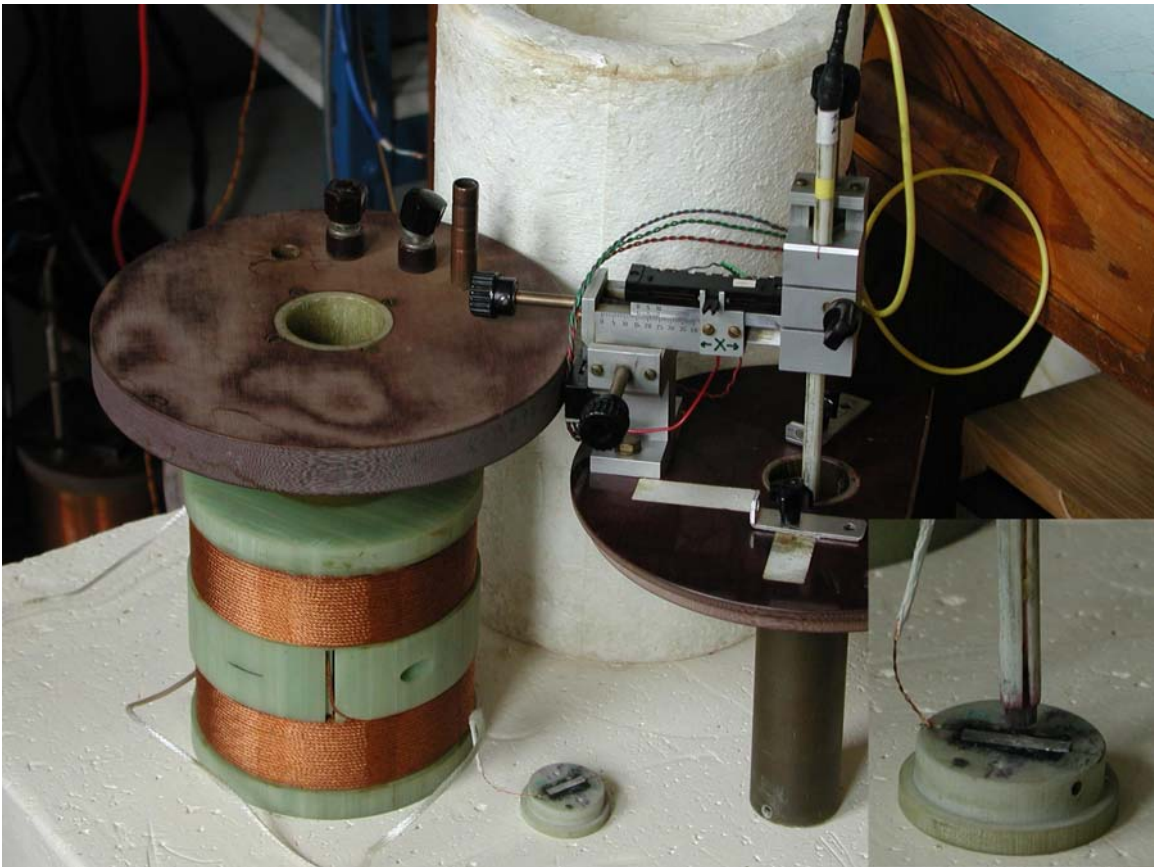

Fig. 4

Measurements at elevated frequencies at 77 K (from 1 Hz up to 1 kHz)

Main parts:

- Cu magnet producing B_e up to 50 mT
- wide band amplifier
- high speed voltmeter (100 000 readings/sec)
- coordinate system

Low frequency measurements at 4.2 K

Main parts:

- low hysteresis superconducting magnet producing 2T
- pick-up coils
- recording system

Measurements at elevated frequencies at 4.2 K

Measurement of longer samples

Some years ago we developed a split race track coil system wound of AC NbTi cable with working space of 20 x 20 mm and length of 180 mm. The maximum field at 50 Hz, 4.2 K was 0.25 T. This magnet is suitable for measurements of longer samples (twisted YBCO tapes).

Self inductance of the coil is 1.34 mH. The inductive voltage at 400 Hz is cca 900 V. Critical current in AC mode is ~265 A.

We suppose that the magnet could be modified so that a higher field could be achieved (reduction of the gap between coils, perhaps insertion of a ferromagnetic yoke).

More detailed data on the coils see:

J. Kokavec, J. Pitel, M. Majoros, M. Polak, Race track dipole magnet with working space 20 x 20 x 180 mm operating at 50 Hz up to 0.25 T, Prague, The fourth International Conference CRYOGENICS '96, Proceedings, page 13-16

The photograph of the coil is in the following Figure:

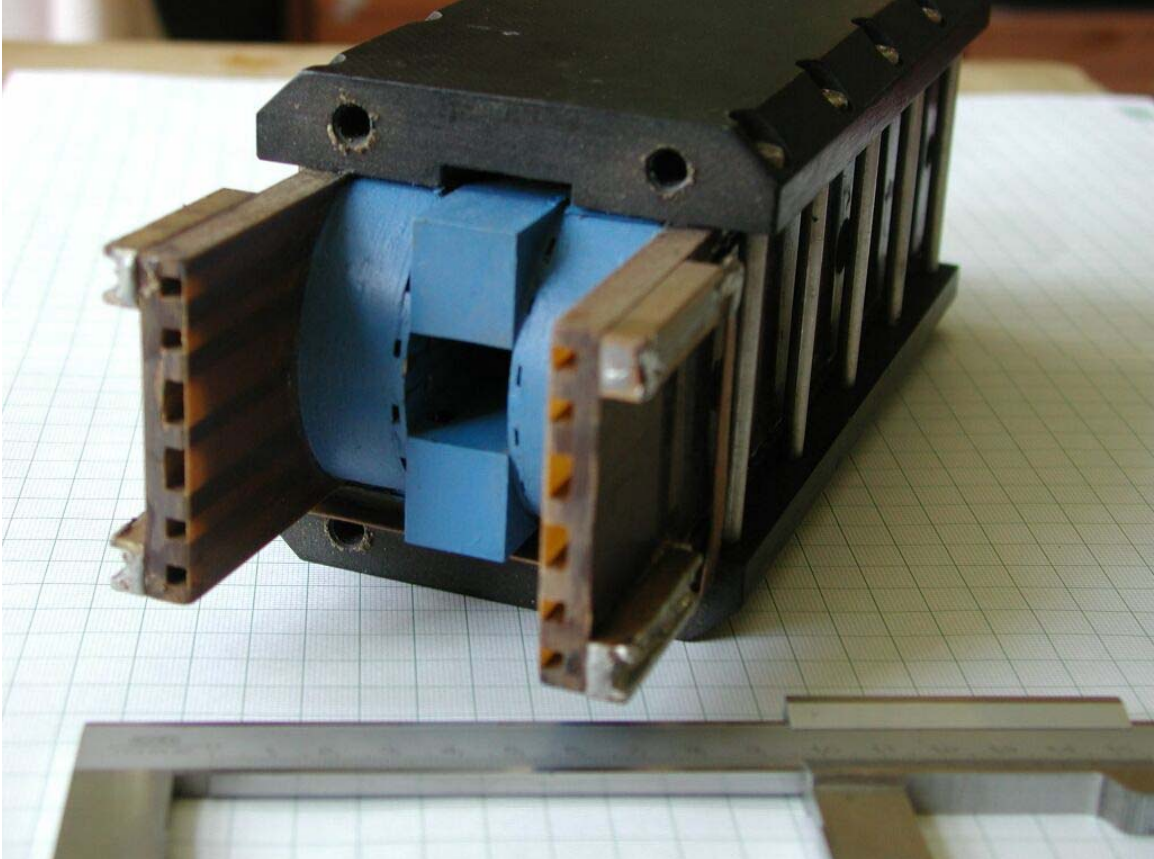
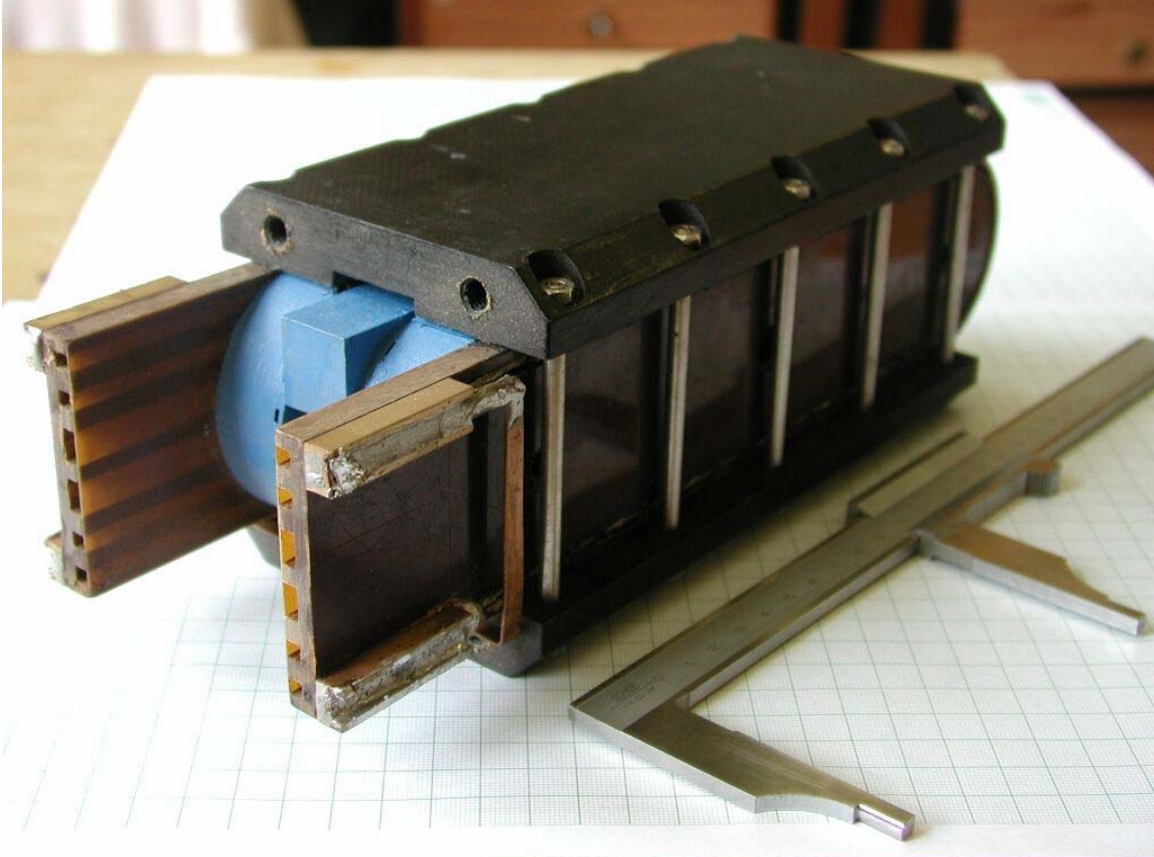

RESULTS

Hysteresis loops $B_s(B_e)$ and I-V curves in rings

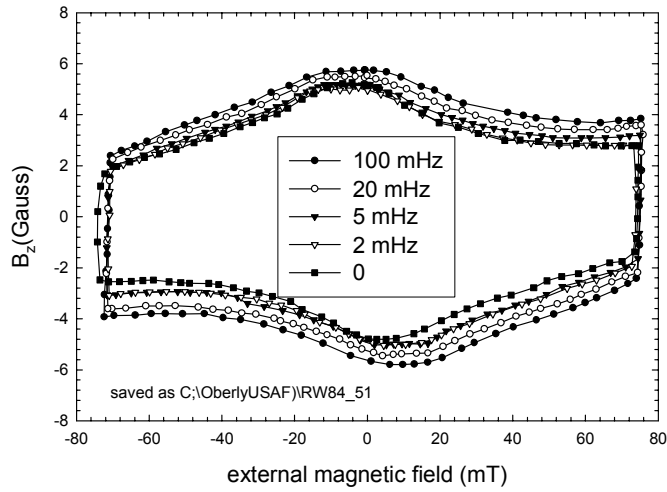

Fig. 5 Ring YBCO on LaAlO with $2w_f = 300$ microns

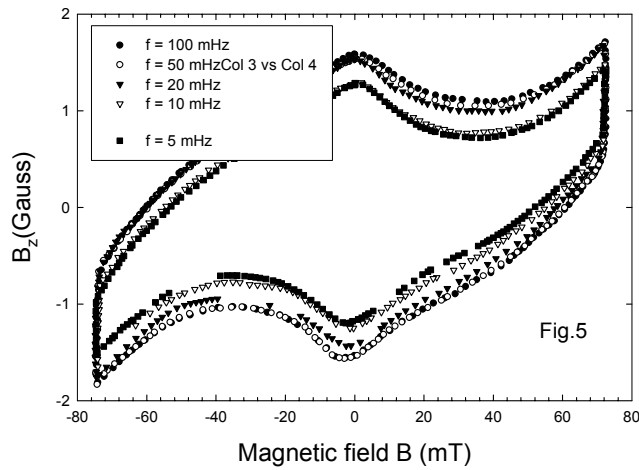

Fig. 6 Ring YBCO on LaAlO with $2w_f = 51$ microns

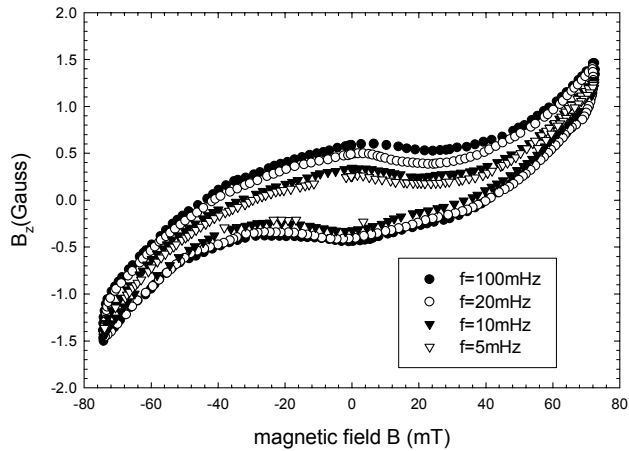

Fig. 7 Ring YBCO on LaAlO with $2w_f = 21$ microns

A comparison of hysteresis curves measured with ring having different $2w_f$

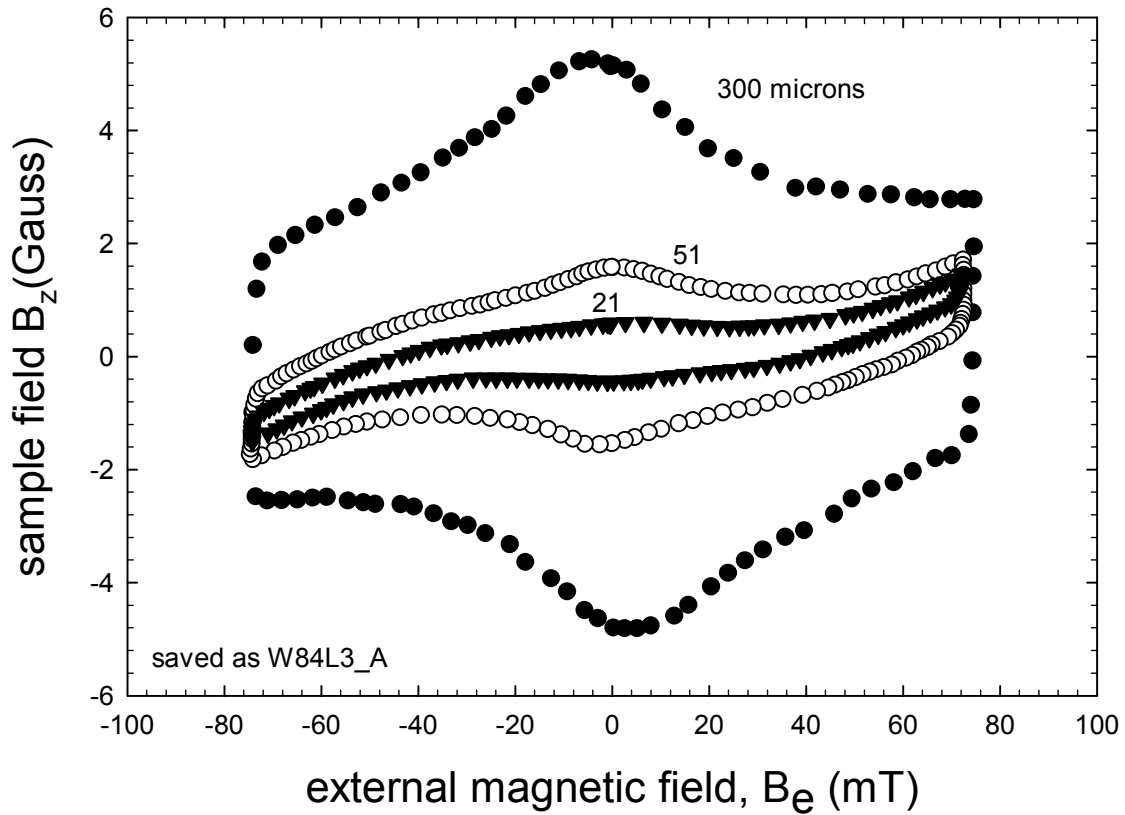

Fig. 8 B_z versus B_e measured with rings 300, 51 and 21 microns at $f = 100$ mHz

The area of the hysteresis loop decreases with decreasing filament width

I-V curves determined from $B_z(B_e)$ measurements in rings at lower frequencies

Electric field-current curves for YBCO rings on LaAlO_3 with current path width 300 microns, 51 microns and 21 microns
 $T = 77 \text{ K}$, $B_e = 0$

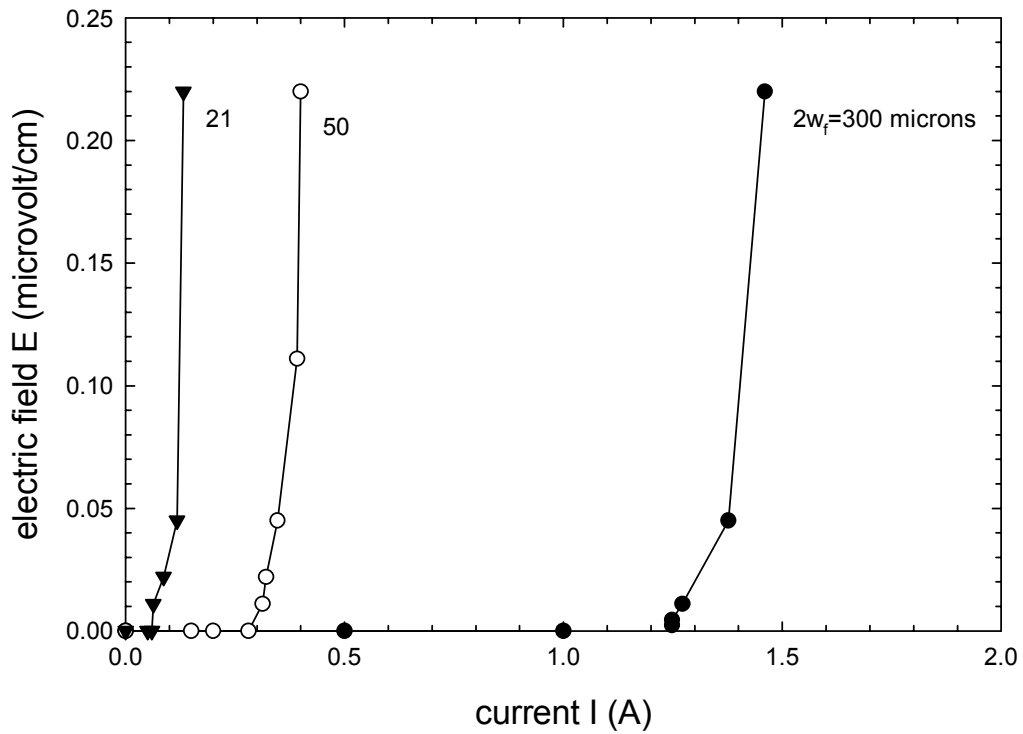

Fig. 9

Magnetic field due to magnetization currents measured in the vicinity of rings in static regime ($dB_e/dt = 0$)

SAMPLES YBCO ON LaAlO

Sample with $2w_f = 300$ microns	Fig. 10
Sample with $2w_f = 51$ microns	Fig. 11
Sample with $2w_f = 21$ microns	Fig. 12

Magnetic field B_z at filamentary sample

Sample with $2w_f = 65$ microns measured at elevated frequencies	Fig. 13
--	----------------

SAMPLES YBCO/Ni (Rings)

Sample with $2w_f = 300$ microns	Fig. 14
Sample with $2w_f = 300$ microns + 97 microns	Fig. 15

Profiles $B_z(y)$ measured at various distances z from the ring plane
Ring W84L3, $2w_f = 300$ microns

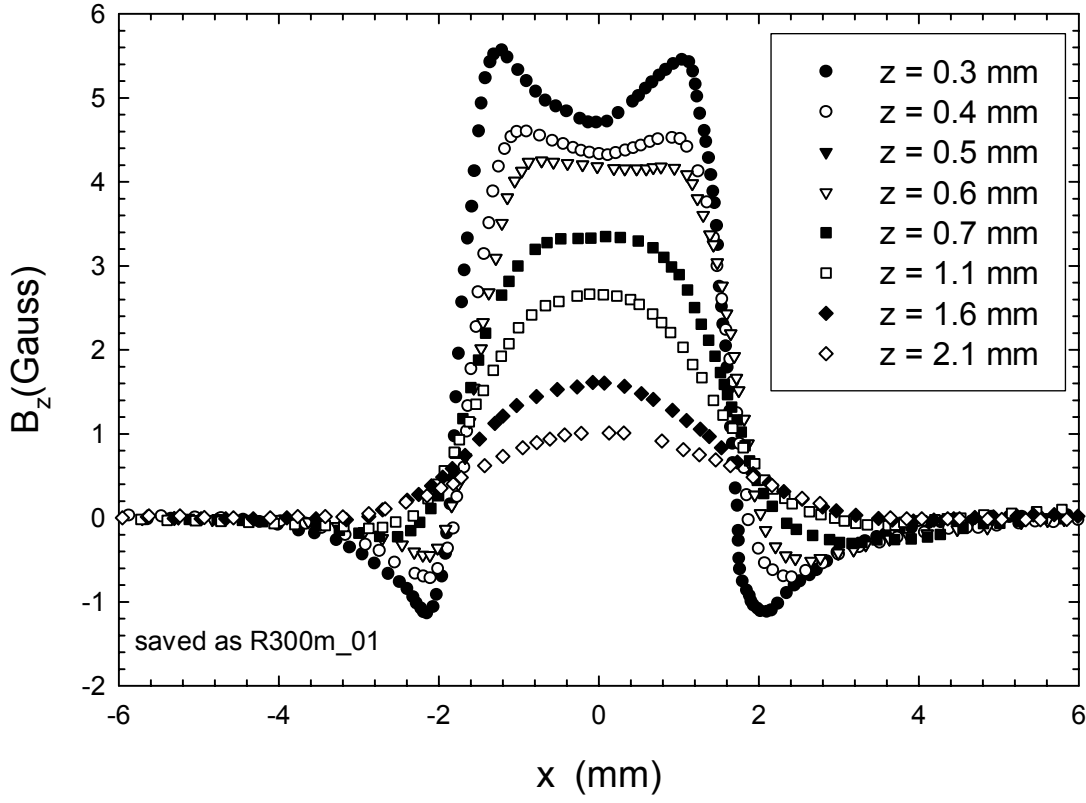
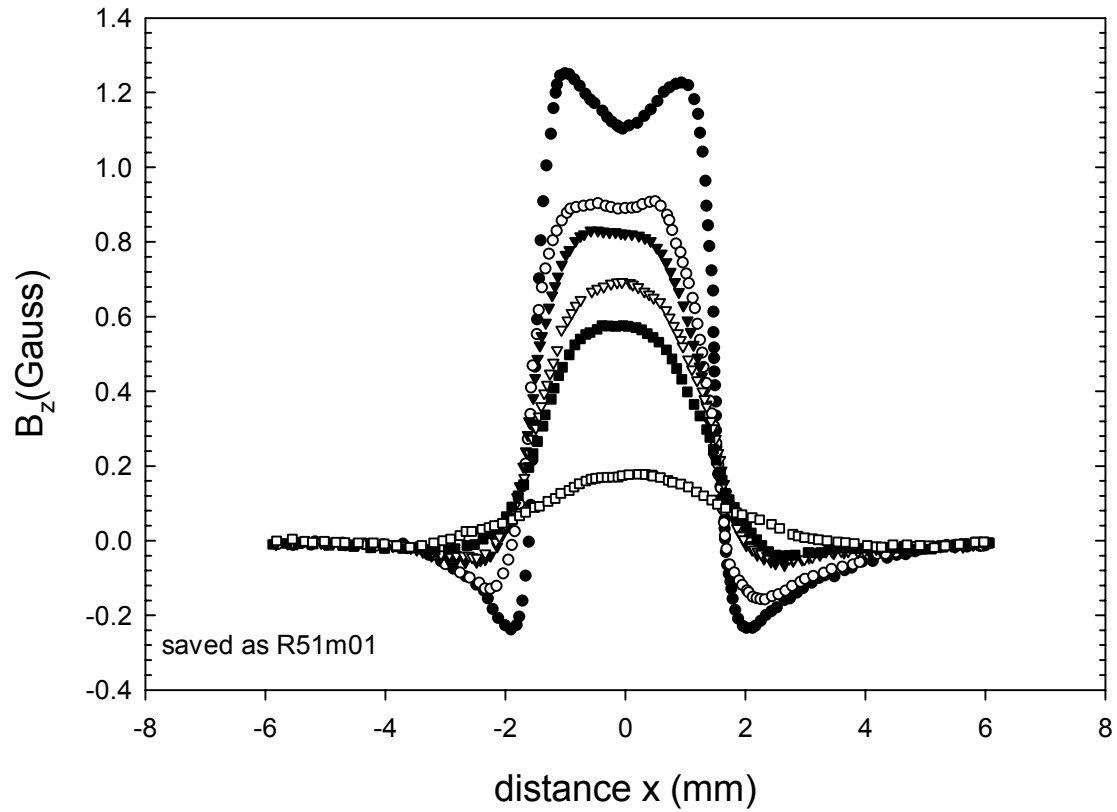

Fig. 10

Profiles $B_z(y)$ measured in various distanced z from the ring plane
Ring W84L3, $2w_f=51$ microns



Distances from the top to the bottom
 $z=8.8$ mm
 $z=8.7$ mm
 $z=8.6$ mm
 $z=8.5$ mm
 $z=8.2$ mm
 $z=7.5$ mm

Fig. 11

W84L3

RING $D_0 = 3$ mm, $2w_f = 21$ microns

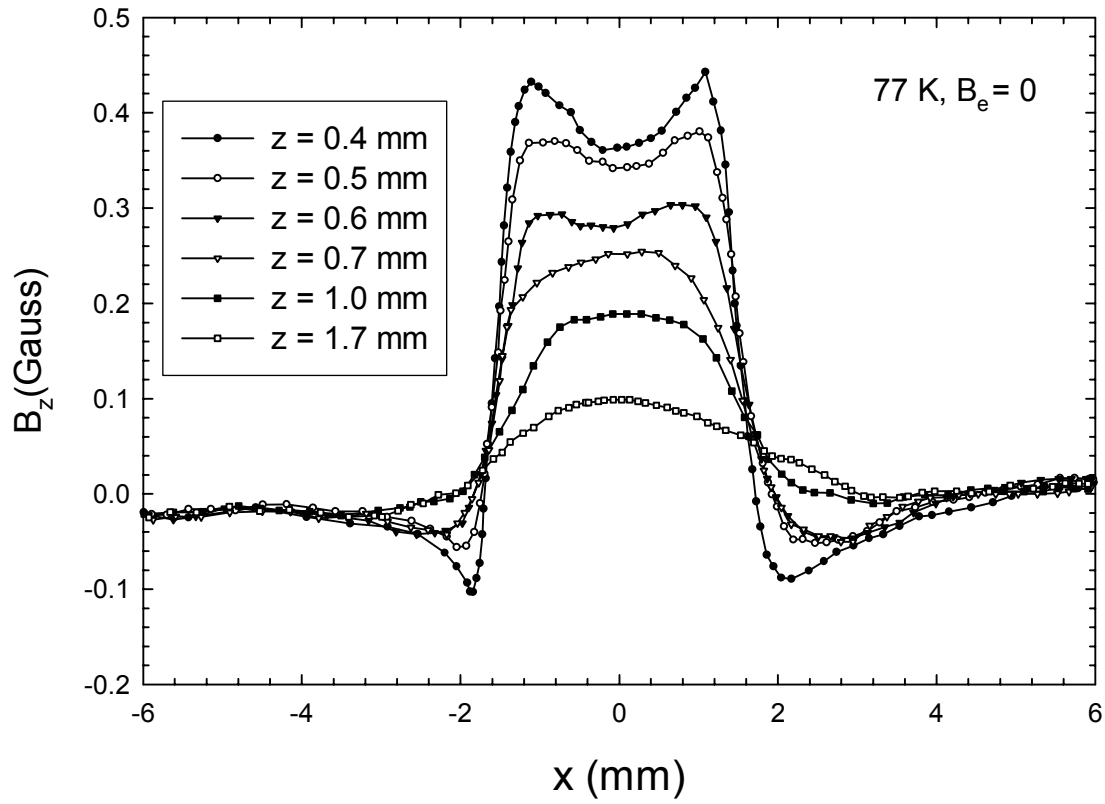

Fig. 12

YBCO on LaAlO₃

Critical currents and hysteresis losses in filaments determined from measurements with rings (curves $B_z = f(B_e)$)

	2w_f = 300μm	2w_f = 51μm	2w_f = 21μm
I _c (0.22μV/cm, B _e =0) [A]	1.46	0.4	0.132
I _{c1} (0.22μV/cm, B _e =0) [A/m]	4.87 10 ³	7.84 10 ³	6.28 10 ³
M(B _e = 0) [Am ²]	1.03 10 ⁻⁵	2.83 10 ⁻⁶	9.32 10 ⁻⁷
A _{h,ring} [J/cycle]	2.02 10 ⁻⁶	4.89 10 ⁻⁷	1.82 10 ⁻⁷
W _{h,ring} (50 Hz) [W]	1.01 10 ⁻⁴	2.45 10 ⁻⁵	9.10 10 ⁻⁶
W_{h,ring}(400 Hz) [W]	8.08 10⁻⁴	1.96 10⁻⁴	7.28 10⁻⁵
2w _f /(πD ₀) ²	10.6	1.8	0.7427
W _{h,fil} (1m, 50 Hz) [W]	1.07 10 ⁻³	4.41 10 ⁻⁵	6.7 10 ⁻⁶
W_{h,fil}(1m, 400 Hz) [W]	8.56 10⁻³	3.53 10⁻⁴	5.36 10⁻⁵

FILAMENTARY SAMPLE, $2w_f = 65$ microns

Magnetic fields due to magnetization currents measured at elevated frequencies (up to 100 Hz)

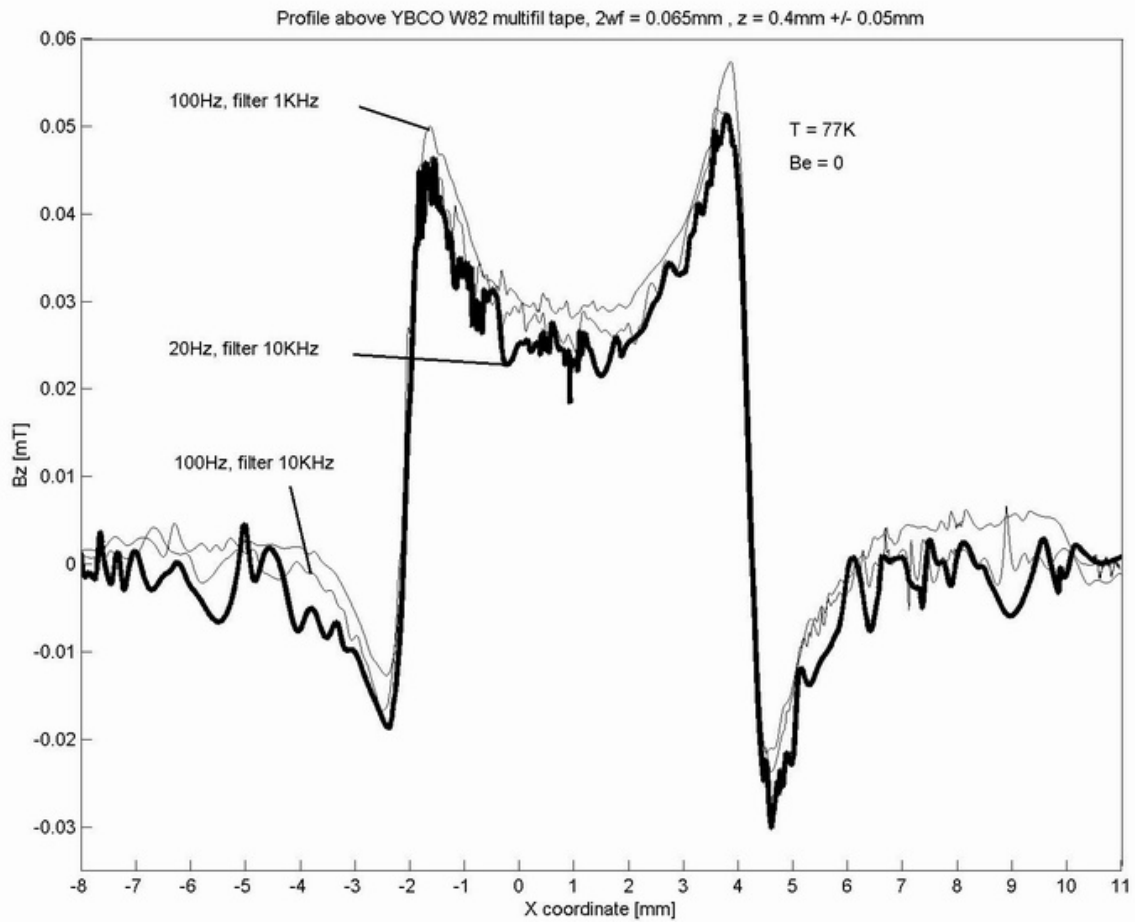

Fig. 13

Magnetic field close to YBCO rings on Ni substrate

Main problem:

a strong contribution of Ni to the measured field and AC losses



in rings with narrow filaments the signal from the superconductor is \ll signal from Ni

Profiles B_z measured with rings with $2w_f = 300$ and 97 microns – a comparison:

B_z measured in the vicinity of YBCO rings with $2w_f = 300$ microns and 97 microns.

The rings are placed on common Ni substrate 10×20 mm

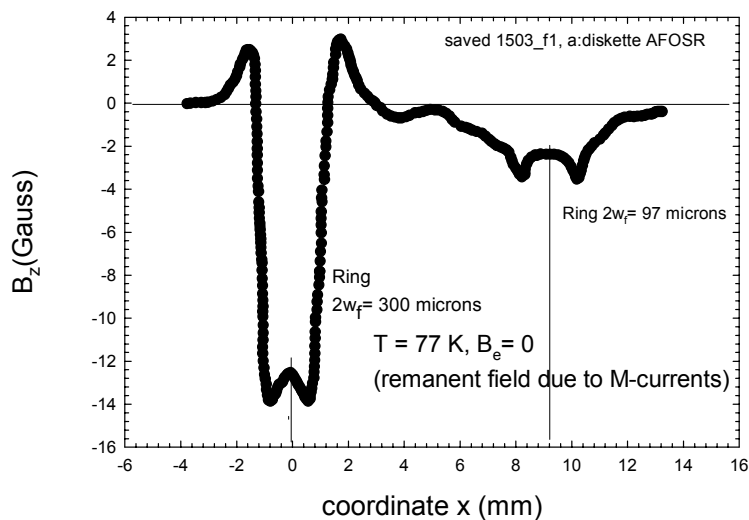

Fig. 14

B_z vs x for YBCO ring on Ni with $2w_f = 300$ microns

$T=77$ K, $B_e = 0$, measured at various distances z

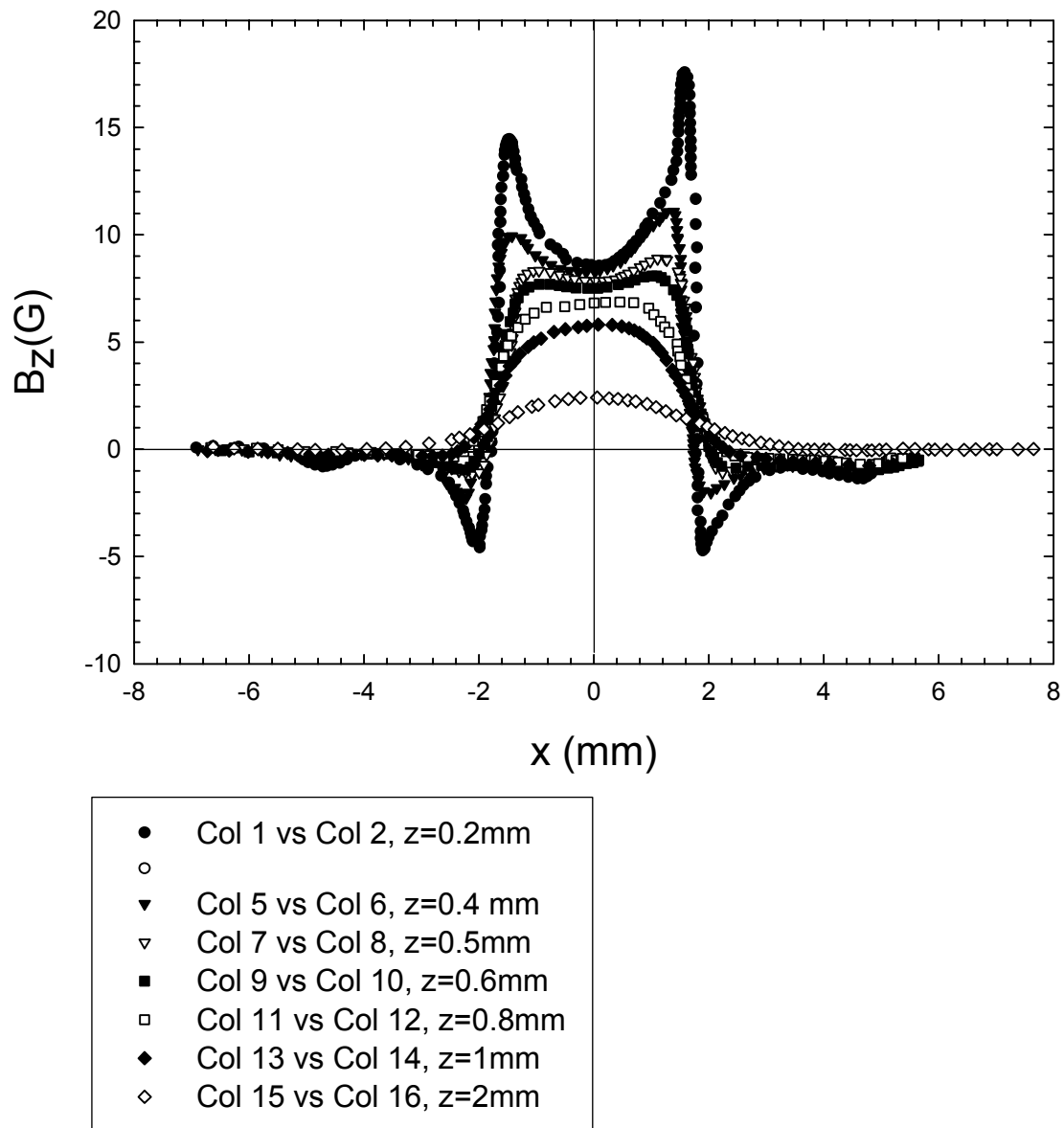

Fig. 15

EXPERIMENTS AT 4.2 K

Set-up: low hysteresis AC coil (operating at 50 Hz up to 2 T)
pick-up coils with cca 5000 turns
analog integrator

Measured samples:

sample with $2w_f = 130$ microns

sample with $2w_f = 65$ microns

Magnetization of filamentary tape sample with $2w_f=130$ microns.
No influence of frequency observed up to ~ 50 mHz

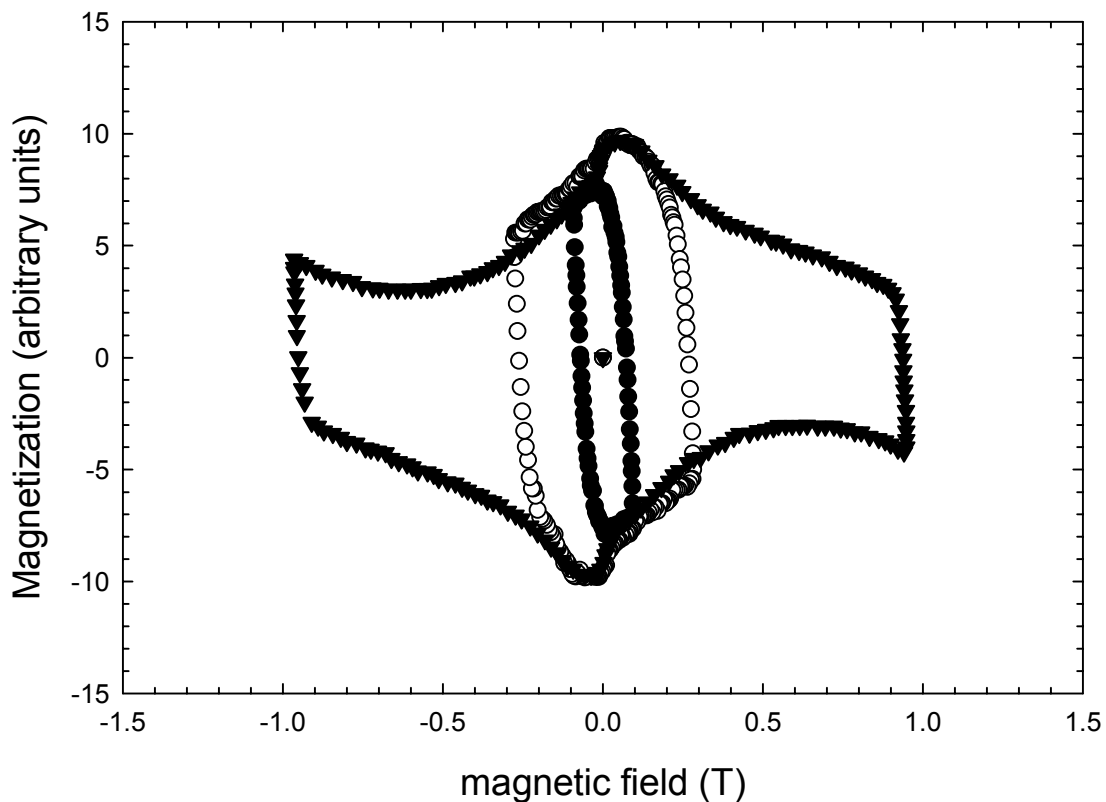

Fig. 16

Understanding of coupling current behavior in filamentary YBCO coated conductors

Parameters affecting coupling current behavior

- a. Architecture of the coated conductor
- b. Properties of the stabilization metal (Ag, Au)
(problems with thicker layers)
- c. Resistivity of the boundary YBCO/stabilization
(good layers have resistivities better than $10^{-6} \Omega\text{cm}^2$)
- d. Properties of the boundary YBCO/buffer layer/substrate (Ni or Ni with additives)
(actually coated conductors use insulation buffer layer)

Parameters affecting effective transverse resistivity, ρ_{eff}

The paths of coupling currents are shown in the following Figure:

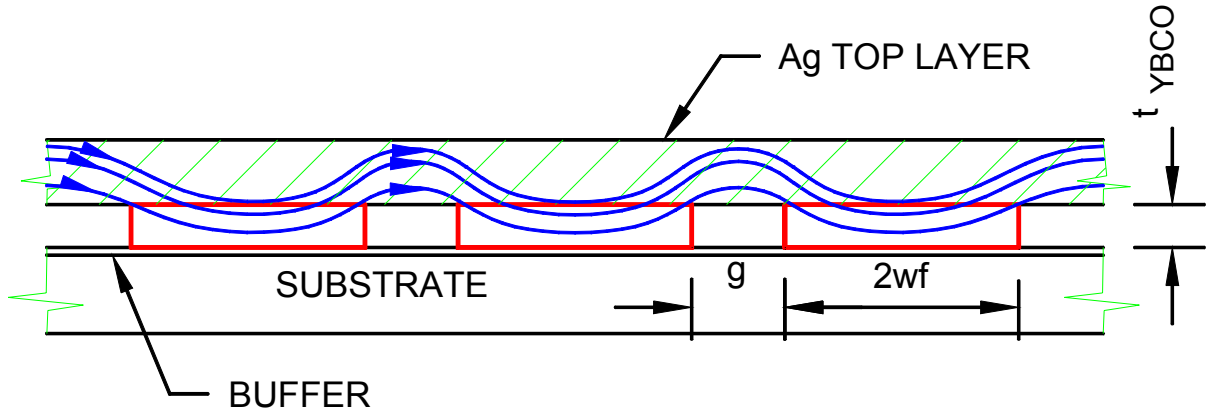

Fig. 17

- R_l resistance of the top Ag layer per unit length [Ω/m]
- ρ_b boundary resistivity YBCO/Ag [Ωm^2]
- $2w_f$ filament width
- g gap between neighboring filaments

An estimate of the boundary resistivity, ρ_b , for a model filamentary tape with the following parameters:

20 filaments with $2w_f = 0.26$ mm, filament thickness 0.25 microns, $g = 0.04$ mm, tape width $2w = 20 \times 0.3$ mm = 6 mm, tape length $L = 1$ cm, $\rho_b = 10^{-6}$ Ωcm^2 (typical value for a “good” layer), $t_{\text{Ag}} = 1$ μm , $T = 77$ K, $\rho_{\text{Ag}}(77) = 2.5 \times 10^{-7}$ Ωcm for bulk samples (see, for example, [4]: Y. Iwasa, et al., Cryogenics 1993 Vol 33 No 8, p. 836)
The silver resistance of 20 gaps with $g = 0.04$ mm is

$$R_{20\text{gaps}} = 20 \rho_{\text{Ag}} g / 2w = 20 \cdot 2.5 \cdot 10^{-7} \Omega\text{cm} \cdot 0.004 \text{ cm} / (1 \text{ cm} \cdot 10^{-4} \text{ cm}) = 2 \times 10^{-4} \Omega$$

Resistance of the boundary filament/Ag per 1 filament

$$R_b = \rho_b / (L \times 2w_f) = 10^{-6} \Omega\text{cm}^2 / (1 \text{ cm} \times 0.026 \text{ cm}) = 3.85 \cdot 10^{-5} \Omega$$

20 filaments in series have the boundary resistance 20 x higher, $R_{b(20fil)}=7.7 \cdot 10^{-4} \Omega$.

The total resistance of the filamentary conductor is

$$R_t = R_{20gaps} + R_{b(20fil)} = 2 \times 10^{-4} + 7.7 \cdot 10^{-4} \Omega = 9.7 \cdot 10^{-4} \Omega$$

and the effective resistivity in the conductor thickness formed by silver and YBCO (1 micron Ag+ 0.25 micron YBCO)

$$\rho_{eff} = R_t (1\text{cm} \times 1.25 \cdot 10^{-4}) / 0.6 \text{ cm} \sim 2 \cdot 10^{-7} \Omega\text{cm}$$

From this example it is seen that increasing the Ag thickness one reduces the transverse resistivity, but this reduction is strongly affected by the transverse resistivity.

Conclusions

1. The reduction of the filament width from 300 microns down to 21 microns did not reduce the critical current I_{c1} in YBCO thin films deposited on LaAlO_3 substrates

Filament width	I_{c1m} (0.22 $\mu\text{V}/\text{cm}$)
300 microns	4870 A
51 microns	7840 A
21microns	6280 A

2. Due to strong contribution of Ni to the sample magnetic field the method to determine I_c in ring samples is applicable for wider filaments only
3. The measured hysteresis losses per 1m long filaments, measured at 100 mHz frequency, triangular field waves, and are the following

300 microns	8.56 mW at 400 Hz
51 microns	0.353 mW at 400 Hz
21microns	0.0536 mW at 400 Hz

Measurements of $B_z(x=0)$ vs frequency for frequencies up to 200 Hz showed only a very little increase of B_z . We believe that hysteresis losses in thin YBCO filaments have a small frequency dependence.

References

- [1] A. M. Campbell, AFOSR Program Review, Stanford, October 2001
- [2] M. Polak, V. Windte, W. Schauer, J. Reiner, A. Gurevich, H. Wuhl, Contactless measurement of voltage-current characteristics of high- T_c thin film superconductors, *Physica C* 174 (1991) 14-22
- [3] M. Polak, W. Zhang, J. Parrell, X. Y. Cai, A. Polyanskii, E. E. Hellstrom, D. C. Larbalestier, M. Majoros, Current transfer length and the origin of linear components in the voltage - current curves of Ag-sheathed BSCCO composites, *Supercond. Sci. Technol.* 10 (1997) 769-777
- [4] Y. Iwasa, et al., *Cryogenics* 1993 Vol 33 No 8, p. 836