

# Naval Surface Warfare Center Carderock Division

West Bethesda, MD 20817-5700

---

NSWCCD-61-TR-2002/07 September 2002

Survivability, Structures, and Materials Directorate

Technical Report

## Process, Chemistry, and Property Relations for Spray Formed NiCr Alloys

by

Leslie K. Kohler

Louis F. Aprigliano

20021010 084



---

Approved for public release: distribution is unlimited.

---

**Naval Surface Warfare Center**  
**Carderock Division**  
West Bethesda, MD 20817-5700

---

**NSWCCD-61-TR-2002/07** September 2002

Survivability, Structures, and Materials Directorate  
Technical Report

**Process, Chemistry, and Property Relations for  
Spray Formed NiCr Alloys**

by

Leslie K. Kohler

Louis F. Aprigliano

# REPORT DOCUMENTATION PAGE

*Form Approved*  
OMB No. 0704-0188



1. AGENCY USE ONLY (Leave blank)	2. REPORT DATE	3. REPORT TYPE AND DATES COVERED Research and Development
----------------------------------	----------------	--

4. TITLE AND SUBTITLE Process, Chemistry, and Property Relations for Spray Formed NiCr Alloys	5. FUNDING NUMBERS
--	--------------------

6. AUTHOR(S) Leslie K. Kohler, Louis F. Aprigliano	
---	--

7. PERFORMING ORGANIZATION NAME(S) AND ADDRESS(ES) Naval Surface Warfare Center, Carderock Division Code 612, Metals Processing and Analysis Branch West Bethesda, Maryland 20817	8. PERFORMING ORGANIZATION REPORT NUMBER  NSWCCD 61-TR-2002/07
--	---

9. SPONSORING/MONITORING AGENCY NAME(S) AND ADDRESS(ES) Dr. Lawrence Kabacoff and Dr. John Sedriks Office of Naval Research 800 North Quincy Avenue Arlington, VA 22217	10. SPONSORING/MONITORING AGENCY REPORT NUMBER
---	---

11. SUPPLEMENTARY NOTES
-------------------------

12a. DISTRIBUTION/AVAILABILITY STATEMENT Distribution unlimited. Approved for public release.	12b. DISTRIBUTION CODE
--	------------------------

<p>13. ABSTRACT (Maximum 200 words)</p> <p>A series of NiCr spray forming runs were completed in order to investigate the mechanisms for exceptional high strength and ductility in previous spray formed 50Ni-50Cr (all compositions in wt%) tubes. Although tests showed good strength results, the best mechanical properties of these spray formed alloys were not achieved in this series. The mechanical properties of this eutectic region alloy were found to be sensitive to small changes in processing parameters and chemical composition. More specifically, it was found that slight increases in chromium and nitrogen content can increase strength but decrease ductility and fracture toughness. Crevice corrosion testing was also performed on a spray formed 50Ni-50Cr disk. After a six month exposure in coastal seawater, the alloy showed no evidence of crevice corrosion. This result may be a result of one or all of three different known corrosion resistance enhancements: small scale spray formed microstructure, increased chromium, and increased nitrogen. Slow strain rate (SSR) tests were also performed on 50Ni-50Cr samples, which showed good performance under freely corroding conditions, but experienced a reduction in maximum load under polarized conditions.</p> <p>Based on the results of this series of NiCr spray forming experiments, it is proposed that future work includes NiCr alloys with slightly higher nickel and lower chromium contents (52Ni-48Cr). These changes are likely to increase fracture toughness values without compromising strength and corrosion resistance. It is also suggested that future corrosion tests compare spray formed and cast NiCr alloys, as well as varying the chromium and nitrogen components in order to pinpoint and capitalize on the reason for the excellent crevice corrosion resistance of the 50Ni-50Cr material.</p>
--

14. SUBJECT TERMS Spray metal forming, Nickel, Chromium, Nitrogen, Incinerator, Corrosion resistance, High temperature, Fasteners, High strength, Crevice corrosion, Slow strain rate	15. NUMBER OF PAGES  17
--	-------------------------------

	16. PRICE CODE
--	----------------

## Contents

	<u>Page</u>
Abstract .....	v
Administrative Information .....	v
Acknowledgements.....	v
Introduction.....	1
Experimental Procedure.....	1
Spray Forming .....	1
Chemical Analysis.....	2
Tensile Specimens and Testing .....	3
Charpy V-Notch Specimens and Testing .....	3
Crevice Corrosion Specimens and Testing.....	3
Slow Strain Rate Specimens & Testing.....	3
Results.....	5
Chemical Composition .....	5
Tensile Properties .....	5
Charpy Impact Results.....	7
Crevice Corrosion Testing.....	7
Slow Strain Rate Testing .....	8
Discussion.....	9
50Ni-50Cr.....	9
50Ni-50Cr: Nitrogen Content Factor.....	10
Chromium Factor.....	11
Chromium + Nitrogen Factor .....	12
Oxygen Factor .....	13
Crevice Corrosion Resistance.....	13
Slow Strain Rate Testing .....	14
Conclusions.....	14
References.....	15
Initial Distribution.....	17

## Tables

Number		<u>Page</u>
1	Description and selected parameters of NiCr spray forming runs.....	3
2	Chemical and mechanical properties of selected cast, wrought, and spray formed NiCr alloys. ....	7
3	Slow strain rate test results for 50Ni-50Cr .....	9

## Figures

Number		<u>Page</u>
1	Motion of substrates during spray forming of tubes and billets. ....	2
2	50Ni-50Cr disk assembly for crevice corrosion test exposure. ....	4
3	Slow strain rate specimen configuration.....	4
4	50Ni-50Cr crevice corrosion test specimen after 6 months exposure. ....	7
5	Same sample as shown in Figure 4, with acid cleaning only.....	8
6	Comparison of tensile properties of 50Ni-50Cr spray formed alloys using different cover gases and substrate shapes.....	9
7	Tensile data as a function of nitrogen content in 50Ni-50Cr spray formed alloys. ....	11
8	Charpy data as a function of nitrogen content in 50Ni-50Cr spray formed alloys. ....	11
9	Dependence of final nitrogen content on chromium content of spray formed NiCr alloys.....	12

## Abstract

A series of NiCr spray forming runs were completed in order to investigate the mechanisms for exceptional high strength and ductility in previous spray formed 50Ni-50Cr\* tubes. Although tests showed good strength results, the best mechanical properties of these spray formed alloys were not achieved in this series. The mechanical properties of this eutectic region alloy were found to be sensitive to small changes in processing parameters and chemical composition. More specifically, it was found that slight increases in chromium and nitrogen content can increase strength but decrease ductility and fracture toughness. Crevice corrosion testing was also performed on a spray formed 50Ni-50Cr disk. After a six month exposure in coastal seawater, the alloy showed no evidence of crevice corrosion. This result may be a result of one or all of three different known corrosion resistance enhancements: small scale spray formed microstructure, increased chromium, and increased nitrogen. Slow strain rate (SSR) tests were also performed on 50Ni-50Cr samples, which showed good performance under freely corroding conditions, but experienced a reduction in maximum load under polarized conditions.

Based on the results of this series of NiCr spray forming experiments, it is proposed that future work includes NiCr alloys with slightly higher nickel and lower chromium contents (52Ni-48Cr). These changes are likely to increase fracture toughness values without compromising strength and corrosion resistance. It is also suggested that future corrosion tests compare spray formed and cast NiCr alloys, as well as varying the chromium and nitrogen components in order to pinpoint and capitalize on the reason for the excellent crevice corrosion resistance of the 50Ni-50Cr material.

## Administrative Information

The work described in this report was performed by the Metals Processing and Analysis Branch (Code 612), Metals Department (Code 61), of the Survivability, Structures and Materials Directorate at the Naval Surface Warfare Center, Carderock Division (NSWCCD). The work was funded by the Office of Naval Research with Dr. Lawrence Kabacoff and Dr. John Sedriks as the ONR project monitors.

## Acknowledgements

The authors would like to thank the following people of the Metals Department for their contributions to this program. Robert Mattox for spray forming, Steven Szpara for machining; Denise Aylor, Conrad Regis, and Dr. David Shifler for corrosion testing, and Dr. Robert Tregoning for mechanical testing.

---

\* All compositions are given in weight percent.

**This page intentionally left blank**

## Introduction

Naval applications such as high strength fasteners and waste incinerators are requiring new and improved alloys for their stringent requirements of corrosion resistance and strength. Commercially available nickel based superalloys are currently used to fill the basic requirements of these applications, but improved alloys are still being sought. Increasing the chromium contents in nickel based alloys is one potential path to their improvement. Specifically, alloys with 40 wt% chromium or greater have shown better strengths, ductility, and hot corrosion resistance than nickel based alloys with 30 wt% chromium or less.<sup>1,2,3,4</sup> These results include NSWC studies in which tensile yield strengths approached 150ksi (1034 MPa). Hot corrosion tests simulating a waste incineration environment showed that spray formed NiCr materials outperformed the current material used on shipboard incinerators (Inconel 690), as well as outperforming another replacement candidate (Haynes 160).<sup>5</sup>

A survey of readily available commercial nickel based alloys showed that chromium content is generally limited to 30% or less (e.g. Inconel 690 (30%), Hastelloy G-30 (30%), Haynes 160 (28%Cr)). The reason for this limitation is that higher chromium contents can lead to alloys that are very brittle and difficult to produce. Spray forming can circumvent some of the processing issues by providing an alloy in near net shape form, and a microstructure that is more amenable to hot working. Past NSWC studies have shown that spray formed 50Ni-50Cr binary alloys exhibited a tensile elongation value of 33% while a cast alloy of the same composition normally has a tensile elongation of 18% or less.<sup>3,4</sup> Spray forming commonly improves ductility by providing a microstructure that is finer and more homogeneous (less segregation).

The successful property results of the past have led to additional spray forming and testing of high chromium nickel based alloys. In this report, additional tensile property tests are reported and provide the basis for evaluating reproducibility and process-property relationships. Impact toughness is also examined through the use of Charpy v-notch test specimens. Finally, initial results of corrosion tests, crevice corrosion and slow strain rate, are reported for 50Ni-50Cr.

## Experimental Procedure

### Spray Forming

Spray forming was performed at the NSWCCD non-reactive research facility using an 80 pound bottom pour melt system. Two different shapes were spray formed, one being a 4-inch inner diameter tube and the other being a 4-inch diameter billet. The general configuration and substrate motion for spray forming each of these shapes is shown in Figure 1. Substrates for tubes were thin mild steel tubes of 4-inches outer diameter and 0.065" wall thickness. Substrates for billets were stainless steel disks of 4-inches diameter and approximately 1/4-inch thickness. All substrate surfaces were grit blasted to maximize sticking efficiency. Final spray formed tube deposits were generally 1-inch thick and 6 to 7 inches in length. Spray formed billets were generally 4 inches in diameter and 4 to 6 inches in length.

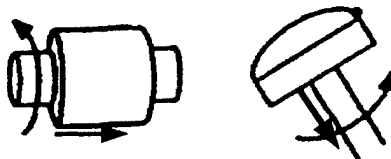

**Figure 1: Motion of substrates during spray forming of tubes and billets.**

Vacuum induction melted (VIM) feedstock was purchased from both Cannon Muskegon and Special Metals in the form of 4-inch diameter ingots. These ingots were cut into lengths of 14 inches or less (40 to 50 pound weights), and melted in an alumina-silica crucible under an inert cover gas of argon or nitrogen. All runs used the VIM charge except for #520, which used excess spray formed material from previous runs as the melt charge.

Atomization gas for all runs was nitrogen. Additional processing parameters such as the ratio of atomization gas flow to molten metal flow (GMR) are listed in Table 1. GMR, melt temperature, and the droplet flight distance (spray height) are the major parameters that regulate the amount of cooling and solidification that takes place in the droplets of the spray. Melt temperature was held at approximately 100°C superheat for all runs, while flight distance was 20.25 inches for all tube runs and 19.5 inches for all billet runs.

**Table 1: Description and selected parameters of NiCr spray forming runs.**

Run #	Billet or Tube (B or T)	Nominal Composition	Cover Gas	GMR*	% Yield
377	T	50Ni - 50Cr	Nitrogen	NR	NR
490	B	50Ni - 50Cr	Argon	1.33	60
513	T	50Ni - 50Cr	Nitrogen	0.59	69
514	T	50Ni - 50Cr	Argon	0.57	67
515	B	50Ni - 50Cr	Nitrogen	1.41	44
516	B	60Ni - 40Cr	Nitrogen	1.39	49
517	B	40Ni - 60Cr	Nitrogen	1.46	45
518	B	48.5Ni - 51.5Cr	Nitrogen	1.52	44
520	B	50Ni - 50Cr	Nitrogen	1.43	31

\* GMR – gas flow to molten metal flow ratio.

## Chemical Analysis

All samples for chemical analysis were sectioned within the bulk of the deposits in order to avoid misleading higher oxygen contents present on the surface. Small, solid samples were sent to Dirats Laboratory in MA for their analysis of chemistry by use of inductively coupled plasma spectroscopy, combustive carbon/sulfur analysis, and inert gas fusion analysis.

## **Tensile Specimens and Testing**

Samples for tensile tests were taken from both billet and tubular spray formed shapes. For tubes, all samples were oriented along the length of the tube. From all billets, blanks for tensile specimens were removed with their length parallel to the billet transverse (T) axis. For billet 515, a tensile blank was also removed with its length oriented parallel to the billet longitudinal (L) axis. Dimensions and testing of the final test specimens were in accordance with ASTM standard E8, with nominal diameters of 0.250 inch.

## **Charpy V-Notch Specimens and Testing**

Samples for Charpy V-notch impact tests were also taken from both billet and tubular spray formed shapes. For the tubes, the samples were oriented along the length of the tube. For the billets, the samples were randomly oriented. Final samples were machined to rectangular dimensions of 0.394" x 0.394" x 2.165" with a 0.315" notch. These dimensions and testing were in accordance with ASTM standard E23.

## **Crevice Corrosion Specimens and Testing**

A round slice was sectioned from near the center height of Run 515, a spray formed billet of 50Ni-50Cr nominal composition. This slice was machined to have parallel faces, straight sides, and a 0.5-inch diameter center hole for a fastener and crevice former. The final disk, having a diameter of approximately 3.75 inches and 0.25 inch thickness, was also ground to a 600 grit surface finish.

The specimen assembly consisted of two non-metallic disks attached to the NiCr specimen disk, with crevices formed by a 1/8-in. thick gasket material (cloth inserted rubber per federal specification HH-P-151F NOT 1)<sup>6</sup>. Prior to immersion in seawater, the specimen was degreased with acetone and then rinsed with ethanol. The crevice assembly was tightened to a torque of 75 in-lbs and immersed in seawater. This assembly is shown in Figure 2 during a routine inspection after 3 months of exposure.

The crevice corrosion specimen assembly was immersed in ambient temperature, filtered natural seawater for a period of 180 days (6 months). Seawater was continuously provided to the test tank during the test period in a once-through arrangement, with seawater flowing at a rate of approximately 3 gallons/minute. After testing, the specimen was scrubbed in detergent and tap water to remove accumulated biofilms. Remaining adherent products were then removed by acid cleaning in accordance with ASTM G1.

## **Slow Strain Rate Specimens & Testing**

Slow strain rate (SSR) testing was conducted on 50Ni-50Cr specimens from runs 513 and 514 at a displacement rate of  $9 \times 10^{-7}$  in/sec. Notched tensile specimens (as shown in Figure 3) were used to simulate the tri-axially stressed region in a fastener. Duplicate specimens were loaded to failure each in air, freely corroding, and cathodically polarized environments. The freely corroding and cathodically polarized tests were conducted in ASTM ocean water per Method D1141, and all potentials were measured versus a silver/silver chloride (Ag/AgCl) reference electrode. The cathodic protection level was -0.850 V versus Ag/AgCl.



Figure 2: 50Ni-50Cr disk assembly for crevice corrosion test exposure.

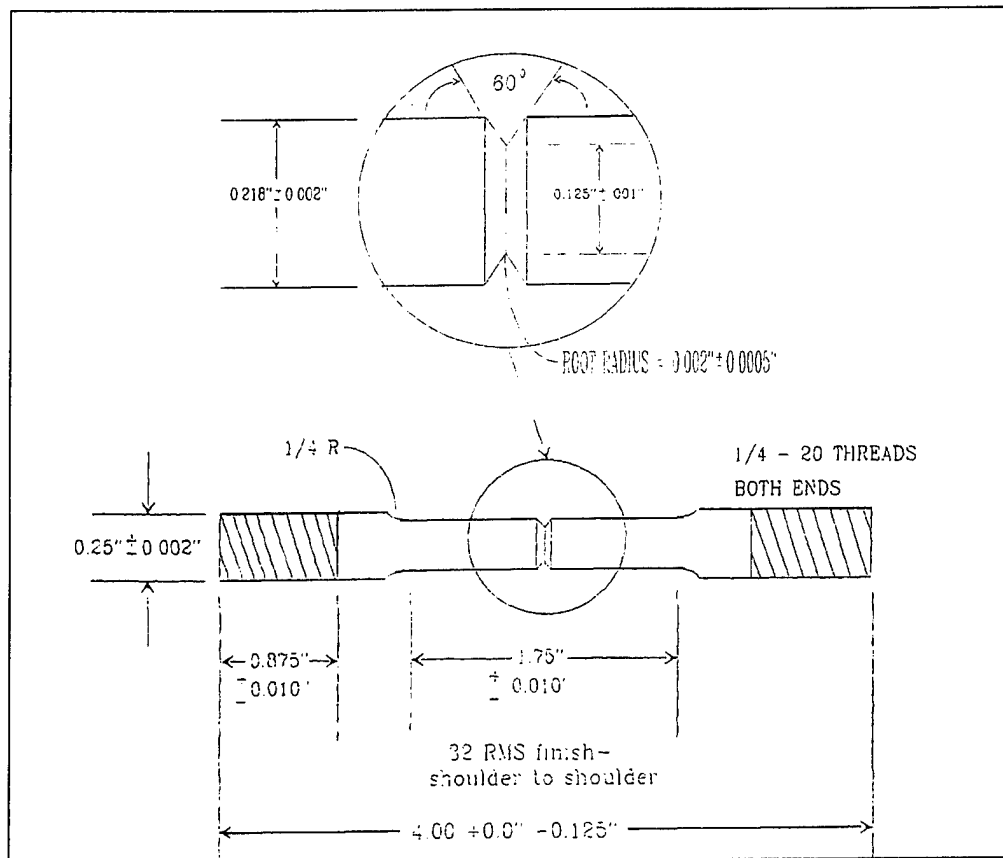

Figure 3: Slow strain rate specimen configuration.

## Results

Most of the data to be discussed is listed in Table 2. This table includes nominal compositions, deposit shape, selected elemental analysis, and mechanical property results. For comparison purposes, Table 2 also includes past spray forming results and published data of similar cast and wrought NiCr alloys.

### Chemical Composition

Samples of spray forming runs were analyzed for Ni, Cr, N, O, Al, Cu, Fe, Mn, P, S, Si, Zr, and C. The first four elements are most important to this report's discussion and are listed in Table 2. Nickel and chromium are the target elements for forming nominal binary compositions of 50Ni-50Cr, 60Ni-40Cr, 40Ni-60Cr, or the eutectic composition of 48.5Ni-51.5Cr. Nitrogen and oxygen are the elements that are most affected by the spray forming process, as they are inevitably introduced in varying amounts during the melting and atomization steps of the process. The remainder of the elements analyzed were either negligible for the amounts present, or did not vary significantly between spray forming runs. More specifically, all samples contained less than 0.01 wt% each of C, Cu, Mn, P, S, and Zr. Al, Si, and Fe can be added to the melt in very small amounts during spray forming as a result of contact with crucible materials. Despite this, Al usually remained at 0.01 wt% or less, Si at 0.03 wt% or less, and Fe at 0.16 wt% or less. Run SFT520 is an exception, having slightly higher amounts of these three elements, since feedstock material was taken from previously spray formed scrap. This effectively doubled the amount of melting time, and therefore exposure, to the crucible materials. Due to the use of spray formed scrap, run SFT520 also had higher than normal amounts of nitrogen and oxygen in the final spray formed product. Nitrogen and oxygen contents for all runs are reported in Table 2.

### Tensile Properties

Past spray forming runs of NiCr compositions have given unusually good combinations of high strength and ductility. In particular, Run SFT377 (50Ni-50Cr nominal composition) produced ultimate and yield strengths averaging 186ksi and 143ksi respectively, while maintaining an average ductility of 33% elongation. Six additional runs of 50Ni-50Cr have since been completed and tested for their tensile properties. The results, listed in Table 2 along with reported values of two standard NiCr alloys, are both encouraging and discouraging. The six most recent 50Ni-50Cr runs had UTS values from 147 to 166 ksi and yield strengths from 88 to 131 ksi. These values continue to show that spray forming improves upon the strength of similar NiCr alloys that are cast and wrought. The same is true for ductility. Average percent elongation values ranged from 20 to 28% for the most recent 50Ni-50Cr runs - well above the 5% and 18% values in cast and wrought NiCr equivalents. Unfortunately, these newer measurements of spray formed tensile strength and ductility do not match those of the original spray forming run SFT377. Reproducibility of the highest strengths has not been achieved.

The most recent series of spray forming runs also included three additional NiCr compositions. Two of the additional compositions increased chromium content (51.5 and 60 wt% Cr), and one of the additional compositions decreased chromium content (40 wt%). In general, strength scales with the amount of Cr at the expense of ductility. This was expected, since increased amounts of Cr typically result in greater amounts of the strong but brittle alpha chromium phase.

Table 2: Chemical and mechanical properties of selected cast, wrought, and spray formed NiCr alloys.

Identification	Chemistry					Mechanical Properties			
	Nominal Composition	Ni (wt%)	Cr (wt%)	N (ppm)	O (ppm)	UTS (ksi)	0.2% YS (ksi)	Elongation %	Charpy Impact (ft-lbs)
<b>Standard Specs</b>									
ASTM A560 (cast)	50Ni - 50Cr	Bal.	48-52	0.3max	-	80	50	5	50 min
Uniloy (wrought)	49Ni-50Cr-1Ti	49.0	50.0	-	-	133	80	18	-
<b>VIM Feedstock</b>									
Melt Charge #D57515	50Ni - 50Cr	50.64	49.21	2	186	-	-	-	60*
Melt Charge #D57516	48.5Ni - 51.5 Cr	48.45	51.52	2	135	-	-	-	-
<b>Spray Formed 50Ni-50Cr</b>									
SF-TN 377	50Ni - 50Cr	48.87	50.32	4010	160	186#	143#	33#	-
SF-BA 490T	50Ni - 50Cr	50.34	49.39	980	290	156	102	21	-
SF-TN 513	50Ni - 50Cr	49.70	49.85	2994	245	173*	132*	24*	13 <sup>5</sup>
SF-TA 514	50Ni - 50Cr	49.79	49.92	1201	256	152#	100#	22#	25*
SF-BN 515T	50Ni - 50Cr	49.98	49.50	2721	273	172*	138*	24*	9 <sup>W</sup> φ
SF-BN 515L	50Ni - 50Cr	49.98	49.50	2721	273	160*	123*	20*	-
SF-BN 520T	50Ni - 50Cr	49.60	49.49	4183	684	156	103	28	9*φ
<b>Spray Formed Other NiCr</b>									
SF-BN 516	60Ni - 40Cr	59.53	40.08	2072	260	105	50	57	180*φ
SF-BN 517T	40Ni - 60Cr	42.36	56.92	4702	346	225	202	1	2*φ
SF-BN 518T	48.5 Ni - 51.5 Cr	48.31	51.22	2760	378	156	130	2	5*φ

Notes: \* - Average (ave.) of 2 samples; # - ave. of 3 samples; ξ - ave. of 5 samples; ψ - ave. of 6 samples; all other data entries are from one sample; φ - samples randomly oriented in billet.

## Charpy Impact Results

Impact toughness of spray formed NiCr alloys was investigated for the first time through use of the Charpy impact test. The average impact value for 50Ni-50Cr spray formed materials is only 14ft-lbs as compared to the cast melt charge #D57515 value of 60ft-lbs. It is likely that the spray formed values suffer significantly as a result of fine porosity that is inherent in as-sprayed materials. A small amount of hot working would likely close these pores and improve the impact values dramatically.

Within the entire series of NiCr spray formed alloys, trends show that impact toughness is dramatically reduced for the dual phase alloys (Cr content >47%). Alloys with chromium contents of 51.5% and above register at very low values of 5 ft-lbs and below. At the other end of the spectrum, these values are substantially increased to an average of 180 ft-lbs when the chromium content is limited to 40% and the nickel content is increased to 60%. The median composition of 50Ni-50Cr had a wider range of results, with values of 9 to 25 ft-lbs. This variability is examined in the Discussion section with respect to chemical composition and processing techniques.

## Crevice Corrosion Testing

After a 6-month exposure, the 50Ni50Cr crevice corrosion test specimen did not show any signs of crevice corrosion. The disk is shown in Figures 4 and 5, before and after cleaning. Once cleaned, the disk looked just as it did prior to testing. In Figure 4, the clean area represents the area that was covered by the crevice forming gasket. If crevice corrosion had occurred, it would be visible at the edge of this clean area. This positive result should prompt additional investigation into the corrosion resistance benefits of high chromium nickel based alloys.

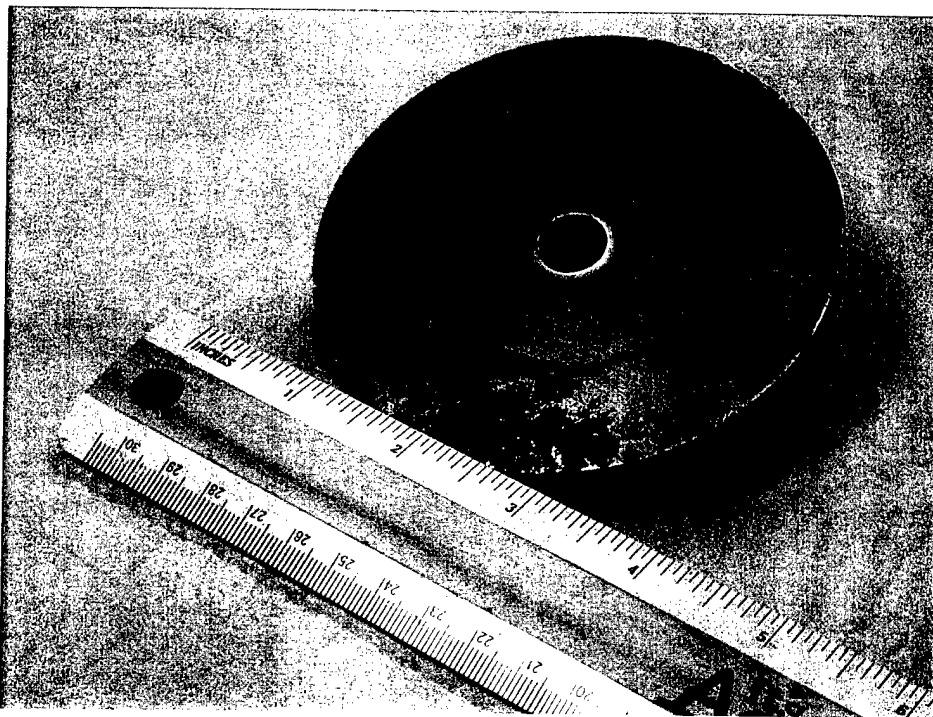
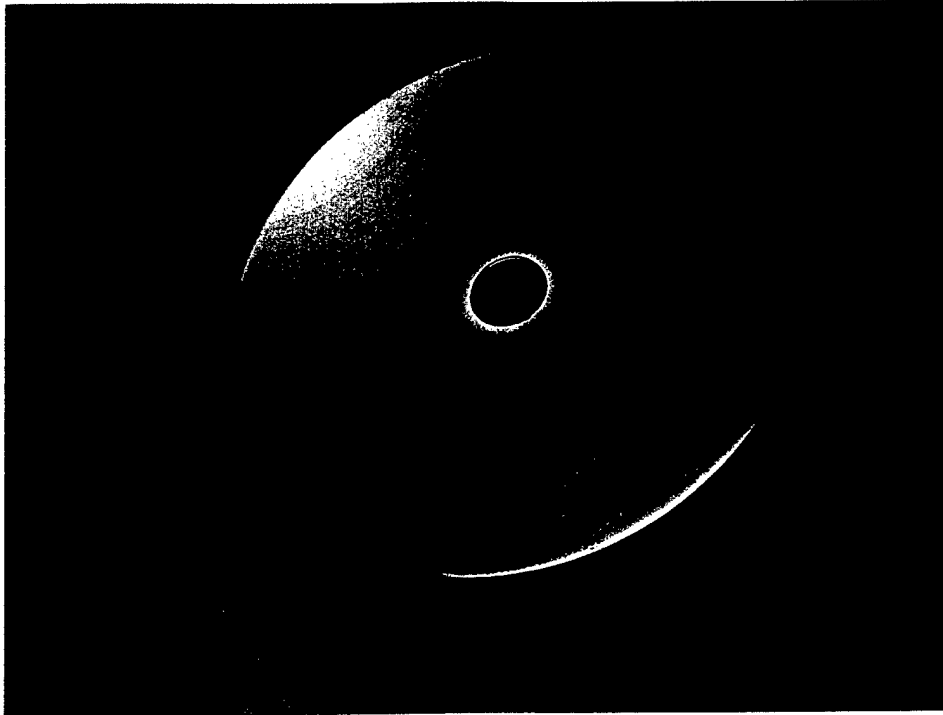

Figure 4: 50Ni-50Cr crevice corrosion test specimen after 6 months exposure.



**Figure 5: Same sample as shown in Figure 4, with acid cleaning only.**

### **Slow Strain Rate Testing**

The results of slow strain rate (SSR) testing are shown in Table 3. Performance is first assessed by calculating the ratio of maximum load in the corrosive environment to the maximum load in air (Environment to Average Air Ratio). The freely corroding specimens performed well with ratios of 1.06 and 1.10, while the polarized specimens performed poorly with ratios of 0.67 and 0.63. Although no SEM analysis of the fracture surface was performed, it is suspected that inter-granular cracking played a role in the poor performance of the polarized specimens.

**Table 3: Slow Strain Rate Test Results for 50Ni-50Cr**

<b>Alloy Identification</b>	<b>Test Run Date</b>	<b>SSRT Environment</b>	<b>Time to Failure (hrs)</b>	<b>Maximum Load (lbs)</b>	<b>Environment to Average Air Ratio</b>
NC1	10/6/00	Air	11.6	2544	----
NC2	10/6/00	Air	11.8	2585	----
NC3	10/16/01	Freely Corroding	16.6	2725	1.06
NC7	10/22/01	Freely Corroding	10.1	2809	1.10
NC5	10/17/01	-850 mV vs Ag/AgCl	6.2	1708	0.67
NC6	10/17/01	-850 mV vs Ag/AgCl	7.6	1619	0.63

## Discussion

### 50Ni-50Cr

The results reported have shown that there is some variability in mechanical property data of spray formed NiCr alloys. This is expected to a certain extent, such as with variation of chromium content and its effect on mechanical properties. In general, the increased presence of Cr (and therefore the microstructural alpha chromium phase) is expected to decrease ductility, increase strength, and decrease impact toughness. But some variability was seen within a single nominal composition - 50Ni50Cr. To investigate these differences, more subtle changes in processing and chemistry were reviewed.

When 50Ni-50Cr spray forming run 490 did not match the prior tensile results of run 377, three effects were pinpointed as possibilities. Nitrogen content, oxygen content, and substrate shape were the differences found between the high and low yield strength products. Run 377 was a tube with a nitrogen content of 4010 ppm, while run 490 was a billet with a nitrogen content of 980. Oxygen content in the billet (run 490) was 290 as opposed to just 160 in the tube (run 377). From these results, it was unclear whether reduced tensile properties were a result of different shapes, processing, chemistry, or a combination of all three.

To sort through nitrogen and shape effects, four different runs were completed under each of the possible processing combinations. Runs 490 and 515 produced billets whose charge was melted under either argon or nitrogen (SF-BA or SF-BN). Similarly, runs 513 and 514 produced tubes under argon or nitrogen (SF-TA or SF-TN) atmospheres. Tensile results clearly showed that there was almost no change in these properties as a result of the shape change, but that the effect of changing cover gases was significant. This effect is shown in Figure 6, which compares the average tensile properties for runs under nitrogen or argon atmosphere and with billet or tubular substrates. Properties for the billet and tube averages (at the right of the graph) are nearly identical, while nitrogen and argon averages (at the left of the graph) are not.

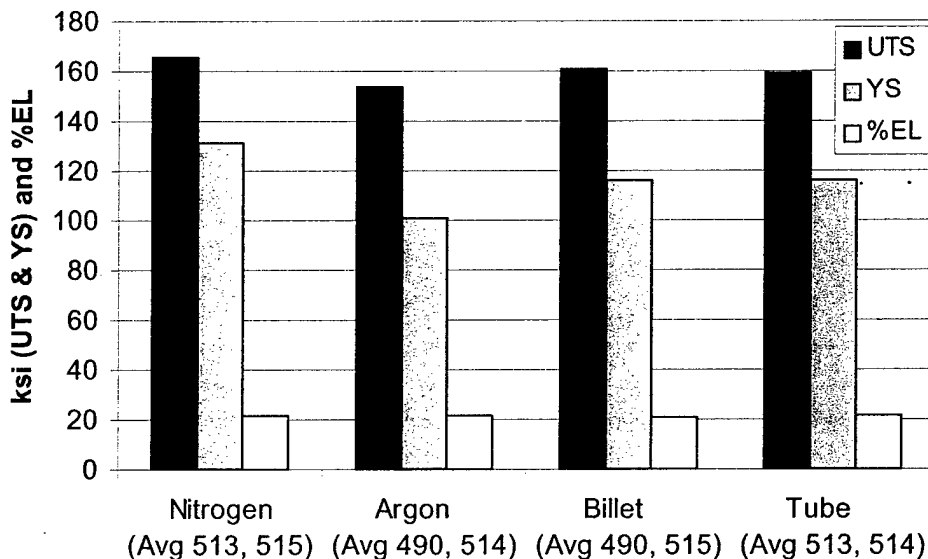

**Figure 6: Comparison of tensile properties of 50Ni-50Cr spray formed alloys using different cover gases and substrate shapes.**

## 50Ni-50Cr: Nitrogen Content Factor

Nitrogen has been added to the spray formed NiCr alloys in varying amounts through melting and atomization. Previous unpublished NSWC results on 304 type stainless steel have shown that changing the crucible overpressure from nitrogen to argon reduces final nitrogen content by approximately 224ppm. A much more pronounced effect is seen in NiCr alloys. Of the alloys listed in Table 2, only three were melted under argon atmosphere - runs 487, 490, and 514. The average final nitrogen content of these 3 runs is 1000ppm, while the average nitrogen content in the remaining runs of 50Ni-50Cr is 3477ppm. With an average difference of 2477ppm, it is easy to see that the choice of melt cover gas can be important to the chemistry of spray formed NiCr alloys. It is also noted that the duration of high temperature melting may have an effect on the final nitrogen content, but that melting times for each of the spray formed NiCr alloys was essentially the same. Changes in atomization gas do not have as remarkable an effect on final nitrogen content, although it appears from the data in Table 2 that tubes may collect slightly more nitrogen than billets. This may be a result of more surface area on the deposit being exposed to impinging atomization gases during processing.

Nitrogen is a known solid solution strengthener in many alloys, and the current set of spray formed 50Ni-50Cr alloys has been analyzed for this effect as well. Figure 7 shows tensile properties as a function of nitrogen content for all spray formed 50Ni-50Cr alloys. In general, this data does appear to show that strength of 50Ni-50Cr benefits from increasing nitrogen content. The exception is run 520, which has the highest nitrogen content but also the highest oxygen content. The trend for ductility, although highest for the largest amounts of nitrogen, needs to be clarified with additional data.

The effect of nitrogen on Charpy values was also analyzed and plotted in Figure 8. Although this chart only includes four data points, it appears that increased nitrogen may have a detrimental effect on the impact toughness of NiCr alloys. It is possible that this decrease in impact toughness occurs with the formation of chromium nitrides ( $\text{CrN}$  or  $\text{Cr}_2\text{N}$ ). These precipitates need to be investigated further to evaluate their presence in the spray formed NiCr alloys. It is also noted that alloy development of NiCr alloys in the 1960's and 1970's included additions of nitride formers such as Nb, Ti, Zr, and others in order to increase the workability of high chromium alloys.<sup>1,2</sup>

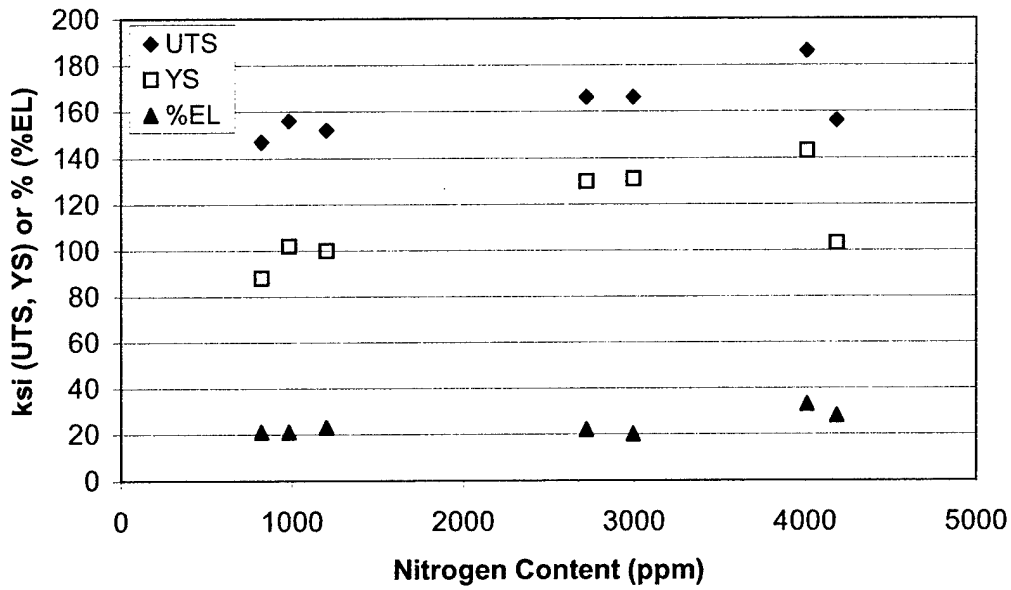

Figure 7: Tensile data as a function of nitrogen content in 50Ni-50Cr spray formed alloys.

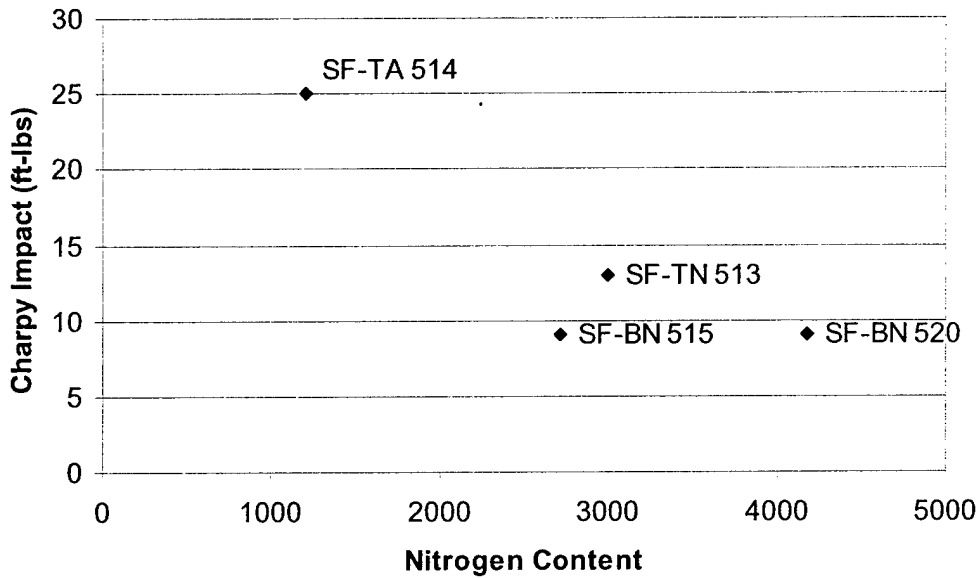

Figure 8: Charpy data as a function of nitrogen content in 50Ni-50Cr spray formed alloys.

### Chromium Factor

As mentioned in the results section, three additional nominal compositions (single phase 60Ni-40Cr, dual phase 40Ni-60Cr, and the eutectic composition 48.5Ni-51.5Cr) confirmed the

expected trend of increasing strength and decreasing ductility with rising chromium contents. Particularly dramatic was the fall of percent elongation from an average of 25% for 50Ni-50Cr to only 2% for 48.5Ni-51.5Cr. This shows that in the region of the eutectic point, property values can be very sensitive to slight composition differences. Similarly, only a 10% reduction in chromium content allowed for a 167ft-lb increase in Charpy impact values. More spray forming runs are needed in order to find a NiCr composition that will give optimum combinations of strength, ductility, and impact toughness. Based on the limited data presented in this report, one composition of interest might be 52Ni-48Cr. This alloy would retain a dual phase microstructure that could provide strength, while limiting the amount of chromium that might contribute to decreased impact toughness values.

### Chromium + Nitrogen Factor

Although these two elements have been analyzed separately for their effects on NiCr alloys, they are not completely independent. Nitrogen content in these spray formed alloys is very dependent on the chromium content of the base alloy. This point is displayed in Figure 9, which plots nitrogen content as a function of chromium content for all spray formed binary NiCr alloys. In this plot, two separate trend lines appear for each of the melting gases, nitrogen and argon, but they both show that alloys with higher chromium contents absorb more nitrogen. It remains to be investigated whether the nitrogen exists in solution or in the form of chromium nitride precipitates. Most likely it is both, and therefore it is difficult to completely separate the effects of these two elements.

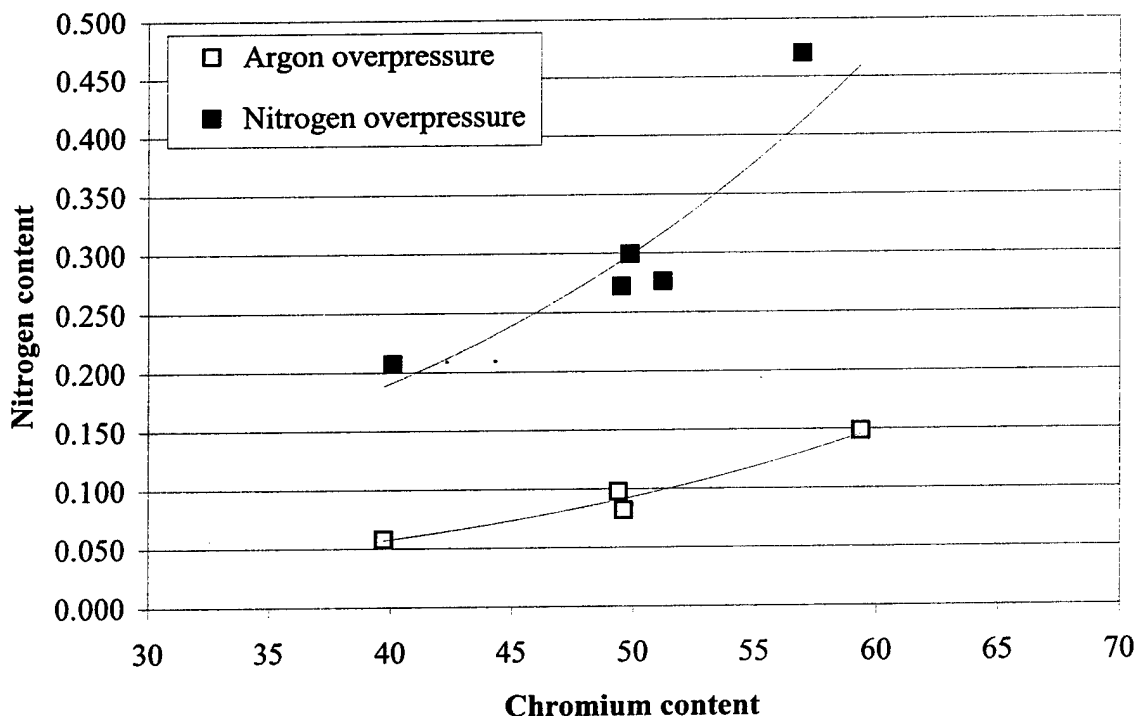

Figure 9: Dependence of final nitrogen content on chromium content of spray formed NiCr alloys.

## **Oxygen Factor**

Although some connections have been made between nitrogen, chromium, and mechanical properties, these things still do not explain the exceptionally good combination of strength and ductility of run #377. One possible cause, that needs to be investigated further, is the difference in the oxygen content of #377 as opposed to later spray formed materials. Run #377 has a ppm oxygen content of only 160, while the remaining runs contain at least 245ppm of oxygen. It is possible that a non-visible change has occurred over time with the spray forming equipment, allowing additional oxygen to creep into the system and therefore the material.

## **Crevice Corrosion Resistance**

For nickel based alloys, chromium and molybdenum are most often added for the purpose of imparting pitting and crevice corrosion resistance. Tests have shown that many alloys need 9% or more molybdenum in order to show no effects of crevice corrosion, even with up to 21% chromium already present.<sup>7</sup> Because of the absence of molybdenum in the spray formed 50Ni-50Cr, some crevice corrosion was expected in the 60 day immersion test. Instead, the alloy showed complete resistance to crevice corrosion. Generally, if an alloy is susceptible to crevice corrosion, visible attack is initiated within the first month of testing.<sup>8</sup> It is therefore reasonable to assume that this NiCr alloy would perform equally as well under longer term tests.

The spray formed 50Ni-50Cr alloy may derive its corrosion resistance from three different mechanisms: 1) Spray formed microstructure, 2) increased nitrogen content, and 3) increased chromium content. Spray forming provides a small scale microstructure and a reduction of segregation because of the relatively rapid solidification. These two characteristics often lead to improved corrosion resistance in all materials. Increased nitrogen has been cited to improve crevice corrosion resistance in some wrought nickel based alloys.<sup>9</sup> Similar claims are made for chromium contents up to 36%.<sup>10</sup> A future crevice corrosion test comparing cast 50Ni-50Cr, spray formed 50Ni-50Cr in both the high and low nitrogen conditions, and a lower chromium content NiCr alloy would help to sort out which effects are at play in these high chromium NiCr alloys.

## **Slow Strain Rate Testing**

Poor results for the polarized specimens of spray formed 50Ni-50Cr cannot be fully assessed without completing an SEM fracture analysis. It is also difficult to assess whether the results are influenced by composition or processing method since only spray formed 50Ni-50Cr alloys were used.

## Conclusions

This investigation has shown that there are benefits to spray forming NiCr alloys under a nitrogen atmosphere. The fine spray formed microstructure contributes to improved strength, ductility, workability, and corrosion resistance. The inherent increase in nitrogen content through melting and atomization gases can also improve strength and corrosion resistance. Although nickel based alloys with chromium contents higher than 30% are known to perform well in extremely corrosive environments, they are not widely available because of the expense and difficulty in processing. Spray forming is one method of processing which may make these high chromium materials of practical use. Improvements in fracture toughness would be necessary but possible through additional refinements in chemistry and light post processing to eliminate residual porosity.

The following specific conclusions can be made from the series of NiCr alloys studied during this investigation.

- Spray formed 50Ni-50Cr alloy showed complete resistance to crevice corrosion during a 6 month exposure in flowing seawater.
- The current series of spray formed 50Ni-50Cr alloys continue to show better tensile strengths and elongations when compared to their cast counterparts and the ASTM A560 specification.
- Charpy impact values of NiCr alloys do not meet the ASTM A560 specification for cast NiCr alloys. It is likely that inherent porosity is the cause.
- Higher chromium containing alloys absorb more nitrogen during the spray forming process than lower chromium containing alloys.
- Higher chromium and nitrogen contents contribute to higher strengths, but lower Charpy impact values.
- Limiting oxygen content in future spray formed materials may allow for optimum tensile properties.
- Spray formed 50Ni-50Cr alloy showed good performance in slow strain rate tests while in a freely corroding seawater environment, but reduced performance under polarized conditions.

## References

- <sup>1</sup> Parry, Bridges, and Taylor, "A New Approach to the problem of the Workability of Nickel-Chromium Alloys Containing 35-70% Chromium", *J. Inst. Metals*, 97, (1969), p. 373.
- <sup>2</sup> Ennis, and Bridges, "The Development of a Cast Ni-50%Cr Alloy Combining Resistance to Service Embrittlement and High Creep Strength", *J. Inst. Metals*, 100, (1972), p. 346.
- <sup>3</sup> Kohler, L. and R. Rebis, "High Chromium Alloys for Shipboard Waste Incinerators" in Advanced Materials and Processing Vol II: PRICM3, 12-16 Jul 1998, Honolulu, HI, TMS, pp. 1669, Warrendale, PA 1998.
- <sup>4</sup> Kohler, Aprigliano, and Madden, *Spray Formed Ni-Cr Alloys for Shipboard Waste Incinerators*, NSWCCD-61-TR-1998/25, Oct 1998.
- <sup>5</sup> Kohler, Shifler, and Aprigliano, "Ni-Cr Alloys for Shipboard Waste Incinerators", *Proc. of the 4<sup>th</sup> International Conference on Spray Forming (ICSF4)*, Baltimore, MD, Sep 1999.
- <sup>6</sup> <http://www.dsp.dla.mil/onlinedocs.htm>
- <sup>7</sup> Corrosion of Metals in Marine Environments, A State of the Art Report by the Metals and Ceramics Information Center, Columbus, OH., Jun 1986, MCIC-86-50.
- <sup>8</sup> Aylor, Hays, and Ferrara, *Crevice Corrosion Performance of Candidate Naval Ship Seawater Valve Materials in Quiescent and Flowing Natural Seawater*, CARDIVNSWC-TR-61-98-29, Jul 1999.
- <sup>9</sup> Nadezhdin, and Wensley, "Composition Factors Affecting Resistance of Ni-Cr-Mo-N Alloys to Crevice Corrosion", in *Materials Performance*, Nov. 1992, p. 57.
- <sup>10</sup> Briant, and Hall, "The Microstructure and Corrosion Resistance of Nickel-Based Filler Metals with High Chromium Contents", in *Welding Research*, Vol. 39, No. 6, Jun 1983, p. 227.

---

This page intentionally left blank

---

### Distribution

	<u>Copies</u>		<u>Copies</u>
<b>DoD CONUS</b>		<b>INTERNAL</b>	
OFFICE OF NAVAL RESEARCH		CODE 60	1
ATTN CODE 334 (KABACOFF)	1	CODE 61 (DENALE)	1
ATTN CODE 332 (SEDRIKS)	1	CODE 612 (APRIGLIANO)	1
800 NORTH QUINCY AVENUE		CODE 612 (KOHLER)	6
ARLINGTON VA 22217		CODE 613 (HAYS)	1
		CODE 613 (SHIFLER)	1
COMMANDER		CODE 613 (AYLOR)	1
ATTN SEA 05M2	1	CODE 614	1
NAVAL SEA SYSTEMS COMMAND		CODE 615 (DELOACH)	1
1333 ISAAC HULL AVE SE STOP 5132			
WASHINGTON NAVY YARD DC 20376-5132			
DEFENSE TECHNICAL INFORMATION CENTER			
8725 JOHN KINGMAN ROAD			
SUITE 0944			
FORT BELVOIR VA 22060-6218	1		