

# NAVAL POSTGRADUATE SCHOOL Monterey, California



## THESIS

**A COMPARATIVE STUDY OF THE PROSPECTIVE  
SOLAR CELLS FOR NPSAT1**

by

Sherrí Rene Mitchell

September 2002

Thesis Advisor:  
Second Reader:

Sherif Michael  
Dan Sakoda

**Approved for public release; distribution is unlimited.**

THIS PAGE INTENTIONALLY LEFT BLANK

REPORT DOCUMENTATION PAGE			Form Approved OMB No. 0704-0188	
Public reporting burden for this collection of information is estimated to average 1 hour per response, including the time for reviewing instruction, searching existing data sources, gathering and maintaining the data needed, and completing and reviewing the collection of information. Send comments regarding this burden estimate or any other aspect of this collection of information, including suggestions for reducing this burden, to Washington headquarters Services, Directorate for Information Operations and Reports, 1215 Jefferson Davis Highway, Suite 1204, Arlington, VA 22202-4302, and to the Office of Management and Budget, Paperwork Reduction Project (0704-0188) Washington DC 20503.				
1. AGENCY USE ONLY (Leave blank)		2. REPORT DATE September 2002	3. REPORT TYPE AND DATES COVERED Master's Thesis	
4. TITLE AND SUBTITLE: Title (Mix case letters) A Comparative Study of the Prospective Solar Cells for NPSAT1			5. FUNDING NUMBERS	
6. AUTHOR(S) Mitchell, Sherri Rene				
7. PERFORMING ORGANIZATION NAME(S) AND ADDRESS(ES) Naval Postgraduate School Monterey, CA 93943-5000			8. PERFORMING ORGANIZATION REPORT NUMBER	
9. SPONSORING /MONITORING AGENCY NAME(S) AND ADDRESS(ES) N/A			10. SPONSORING/MONITORING AGENCY REPORT NUMBER	
11. SUPPLEMENTARY NOTES The views expressed in this thesis are those of the author and do not reflect the official policy or position of the Department of Defense or the U.S. Government.				
12a. DISTRIBUTION / AVAILABILITY STATEMENT Approved for public release; distribution unlimited.			12b. DISTRIBUTION CODE	
13. ABSTRACT (maximum 200 words)  The Naval Postgraduate School's next satellite to be launched will be the technology demonstration experiment NPSAT1 in 2006. This satellite will be laden with some of the school's top research projects including on orbit solar cell I-V curve testing. The designers of this satellite were presented with three types of solar cells with which to power their satellite: silicon, gallium arsenide, and triple junction cells. This thesis evaluates those three types of cells on the merits of their advertised and tested efficiency, cost, performance, and reaction to radiation experiments. Although the triple junction cells have already been selected to provide solar power to the onboard experiments, the background justification for such cells is warranted.				
14. SUBJECT TERMS  NPSAT1, solar cells, solar simulator, LINAC			15. NUMBER OF PAGES  72	
			16. PRICE CODE	
17. SECURITY CLASSIFICATION OF REPORT  Unclassified	18. SECURITY CLASSIFICATION OF THIS PAGE  Unclassified	19. SECURITY CLASSIFICATION OF ABSTRACT  Unclassified	20. LIMITATION OF ABSTRACT  UL	

THIS PAGE INTENTIONALLY LEFT BLANK

**Approved for public release; distribution is unlimited.**

**A COMPARATIVE STUDY OF THE PROSPECTIVE SOLAR CELLS FOR  
NPSAT1**

Sherry R. Mitchell  
Lieutenant, United States Navy  
B.S., United States Naval Academy, 1998

Submitted in partial fulfillment of the  
requirements for the degree of

**MASTER OF SCIENCE IN SPACE SYSTEMS OPERATIONS**

from the

**NAVAL POSTGRADUATE SCHOOL  
September 2002**

Author:

Sherry Rene Mitchell

Approved by:

Sherif Michael  
Thesis Advisor

Dan Sakoda  
Second Reader

Rudy Panholzer  
Chairman, Space Systems Academic Group

THIS PAGE INTENTIONALLY LEFT BLANK

## **ABSTRACT**

The Naval Postgraduate School's next satellite to be launched will be the technology demonstration experiment NPSAT1 in 2006. This satellite will be laden with some of the school's top research projects including on orbit solar cell I-V curve testing. The designers of this satellite were presented with three types of solar cells with which to power their satellite: silicon, gallium arsenide, and triple junction cells. This thesis evaluates those three types of cells on the merits of their advertised and tested efficiency, cost, performance, and reaction to radiation experiments. Although the triple junction cells have already been selected to provide solar power to the onboard experiments, the background justification for such cells is warranted.

THIS PAGE INTENTIONALLY LEFT BLANK

## TABLE OF CONTENTS

<b>I.</b>	<b>INTRODUCTION TO NPSAT1 .....</b>	<b>1</b>
A.	<b>NPSAT1 BACKGROUND .....</b>	<b>1</b>
B.	<b>THESIS OBJECTIVES AND LIMITATIONS.....</b>	<b>2</b>
<b>II.</b>	<b>NPSAT1 SATELLITE OVERVIEW .....</b>	<b>3</b>
A.	<b>MISSION AND EXPERIMENTS.....</b>	<b>3</b>
B.	<b>NPSAT1 PHYSICAL CHARACTERISTICS .....</b>	<b>3</b>
C.	<b>ORBIT INFORMATION .....</b>	<b>5</b>
<b>III.</b>	<b>SOLAR POWER.....</b>	<b>7</b>
A.	<b>SOLAR POWER INPUT.....</b>	<b>7</b>
B.	<b>THERMAL TEMPERATURE OF SKIN.....</b>	<b>7</b>
<b>IV.</b>	<b>PAYLOAD POWER BUDGET.....</b>	<b>17</b>
A.	<b>EXPERIMENTS.....</b>	<b>17</b>
B.	<b>ESTIMATED POWER REQUIREMENTS .....</b>	<b>20</b>
<b>V.</b>	<b>SILICON CELLS .....</b>	<b>23</b>
A.	<b>NPSAT1 PROSPECTIVE SILICON CELLS .....</b>	<b>23</b>
B.	<b>TEST CELLS AND PROCEDURES .....</b>	<b>25</b>
1.	<b>Background.....</b>	<b>25</b>
2.	<b>Solar Simulator Testing.....</b>	<b>25</b>
3.	<b>LINAC Testing .....</b>	<b>27</b>
C.	<b>FINDINGS .....</b>	<b>30</b>
<b>VI.</b>	<b>GALLIUM ARSENIDE CELLS.....</b>	<b>33</b>
A.	<b>NPSAT1 PROSEPECTIVE GALLIUM ARSENIDE CELLS.....</b>	<b>33</b>
B.	<b>TEST CELLS AND PROCEDURES .....</b>	<b>34</b>
1.	<b>Background.....</b>	<b>34</b>
2.	<b>Solar Simulator Testing.....</b>	<b>34</b>
3.	<b>LINAC Testing .....</b>	<b>35</b>
C.	<b>FINDINGS .....</b>	<b>37</b>
<b>VII.</b>	<b>TRIPLE JUCTION CELLS .....</b>	<b>41</b>
A.	<b>NPSAT1 PROSPECTIVE TRIPLE JUCTION CELLS .....</b>	<b>41</b>
B.	<b>TEST CELLS AND PROCEDURES .....</b>	<b>43</b>
1.	<b>Background.....</b>	<b>43</b>
2.	<b>Solar Simulator Testing.....</b>	<b>43</b>
3.	<b>LINAC Testing .....</b>	<b>44</b>
C.	<b>FINDINGS .....</b>	<b>46</b>
<b>VIII.</b>	<b>FOLLOW-ON WORK AND CONCLUSIONS.....</b>	<b>49</b>
A.	<b>FOLLOW-ON WORK .....</b>	<b>49</b>
B.	<b>CONCLUSIONS.....</b>	<b>49</b>

<b>APPENDIX A.</b> .....	<b>51</b>
<b>APPENDIX B.</b> .....	<b>53</b>
<b>APPENDIX C.</b> .....	<b>55</b>
<b>LIST OF REFERENCES</b> .....	<b>57</b>
<b>INITIAL DISTRIBUTION LIST</b> .....	<b>59</b>

## LIST OF FIGURES

Figure 1.	Older NPSAT1 Design [From Ref. 6].....	3
Figure 2.	Later NPSAT1 Design [From Ref. 8]. .....	4
Figure 3.	Latest NPSAT1 Design [From Ref. 9].....	5
Figure 4.	NPSAT1 Solar Power Input [From Ref. 10].....	6
Figure 5.	NPSAT1 Equipment Plates [From Ref. 10].....	7
Figure 6.	Thermal Results Animation Still [From Ref. 10].....	8
Figure 7.	(+/- X) Facing Panels [From Ref. 10].....	8
Figure 8.	(+X) Facing Panel Temperatures [From Ref. 10].....	9
Figure 9.	(+X) Panels-Single Orbit [From Ref. 10] .....	9
Figure 10.	Elements Temperatures Simulation [From Ref. 10] .....	10
Figure 11.	Element Temperatures Simulation [From Ref. 10].....	10
Figure 12.	(-X) Facing Panel Temperatures [From Ref. 10].....	11
Figure 13.	(-X) Panels Single Orbit [From Ref. 10].....	11
Figure 14.	Element Temperatures Simulation [From Ref. 10].....	12
Figure 15.	Element Temperatures Simulation [From Ref. 10].....	12
Figure 16.	(+/- Y) Facing Panels [From Ref. 10] .....	13
Figure 17.	(+Y) Facing Panel Temperatures [From Ref. 10].....	13
Figure 18.	(+Y) Panels Single Orbit [From Ref. 10].....	14
Figure 19.	(-Y) Facing Panels Temperatures [From Ref. 10].....	14
Figure 20.	(-Y) Panel Temperatures Single Orbit [From Ref. 10] .....	15
Figure 21.	Li-ion Battery Charge/Discharge Tables [From Ref. 13] .....	18
Figure 22.	Li-ion Battery Data Table [From Ref. 13] .....	18
Figure 23.	Experiment Layout on NPSAT1 [From Ref. 9].....	20
Figure 24.	NPSAT1 Silicon Solar Panels [From Ref. 6].....	23
Figure 25.	Silicon K6700B Solar Cells [From Ref. 11].....	24
Figure 26.	Product Description [From Ref. 11].....	24
Figure 27.	Silicon I-V Curve [From Ref. 11].....	25
Figure 28.	Xenon Arch Lamp and the Sun's Spectrum at AM0 Cond. [From Ref. 2] .....	26
Figure 29.	Solar Simulation Set-up [From Ref. 2] .....	26
Figure 30.	Silicon Cell Base-line IV Curve [From Ref. 15].....	27
Figure 31.	Silicon Cell Pmax during LINAC Testing [From Ref. 15].....	28
Figure 32.	Silicon Cell LINAC Testing Efficiency Results [From Ref. 15].....	28
Figure 33.	Composite LINAC Testing Imax Results [From Ref. 15] .....	29
Figure 34.	Silicon Cell LINAC Testing Voc Results [From Ref. 15].....	29
Figure 35.	Silicon Cell LINAC Radiation Composite Curves [After Ref. 15].....	30
Figure 36.	Manufacturer's Radiation Data on Silicon Cell [From Ref. 11].....	31
Figure 37.	GaAs/Ge Single Junction Cell [From Ref. 3] .....	33
Figure 38.	GaAs/Ge Cell [From Ref. 3].....	33
Figure 39.	GaAs/Ge I-V Curve [From Ref. 3].....	34
Figure 40.	GaAs Solar Simulator Baseline I-V Curve [From Ref. 15] .....	35
Figure 41.	GaAs LINAC Testing Efficiency Curve [From Ref. 15].....	36
Figure 42.	GaAs LINAC Testing Pmax Curve [From Ref. 15].....	36

Figure 43.	GaAs LINAC Testing I <sub>max</sub> Curve [From Ref. 15] .....	37
Figure 44.	GaAs Cell LINAC Radiation Test Composite [After Ref. 15] .....	37
Figure 45.	Normalized P <sub>max</sub> vs 1 Mev Electron Fluence [From Ref. 12].....	38
Figure 46.	Ga/As Ge Radiation Degredation [From Ref. 3].....	39
Figure 47.	Triple Junction Cell [From Ref. 4].....	41
Figure 48.	Triple Junction Cell Parameters [From Ref. 4].....	42
Figure 49.	Typical I-V for Triple Junction Cell [From Ref. 4] .....	42
Figure 50.	Multi-Junction Cell Baseline I-V Curve [From Ref. 15] .....	43
Figure 51.	Triple-Junction Cell LINAC Testing Efficiency Curve [From Ref. 15].....	44
Figure 52.	Triple-Junction Cell LINAC Testing P <sub>max</sub> Curve [From Ref. 15] .....	45
Figure 53.	Triple-Junction Cell LINAC Testing I <sub>max</sub> Curve [From Ref. 15] .....	45
Figure 54.	Triple-Junction Cell LINAC Radiation Testing Composite [After Ref. 15]..	46

## LIST OF TABLES

Table 1.	Estimated NPSAT1 Power Budget [From Ref. 9]. .....	21
----------	--	----

# I. INTRODUCTION TO NPSAT1

## A. NPSAT1 BACKGROUND

The Space Systems Academic Group at the Naval Postgraduate School (NPS) designs small satellites in order to facilitate education of officer students, research in spacecraft technology and spacecraft design, to study the environmental effects on semiconductors, and to conduct other experiments in the space environment. NPS also has a command ground station that maintains contact with the satellites. The NPS satellites typically have a fairly short mission life and are launched as a secondary payload. The last NPS satellite launched was the Petite Amateur Navy Satellite (PANSAT), which was put into orbit by the Discovery shuttle in 1998.

The next scheduled satellite to be launched for the Naval Postgraduate School (NPS) is NPSAT1 in January 2006. This satellite is manifested on the Department of Defense Space Test Program MLV-05 Delta IV mission. The satellite's two-year mission in low-earth orbit is to conduct a variety of experiments for the primary sponsors as well as some experiments for NPS. The use of Commercial Off-The-Shelf (COTS) technology in space will be tested and IV curve testing in space will be done on some of the latest technology solar cells. The estimated power requirement for the satellite and its systems is an average of 18-20 W with a peak power requirement of 27 W during data transmission to the earth station. Batteries will be used to source power requirements while the satellite is in the eclipse portion of its orbit. The optimum solar cell layout based upon the manufacturer's available cells and cell sizes was determined to be a total of eleven 18-cell strings on each side of the 12-sided cylindrically shaped satellite. The individual cell is a 1.64 cm X 1.64 cm Improved Triple Junction (ITJ) cell with efficiency of around 24 percent. The maximum power output of the solar array at end of life is estimated to be 74.8 W when the satellite is perpendicular to the sunlight. Cover glass (shielding) for this cell will be 12 mil which is required due to the cell's fragility. The battery system consists of two 8-cell banks of memory-less polymer rechargeable cells, thermally insulated and heated, that provide a combined total of 3.8 Amps per hour at 24-33 V.

## **B. THESIS OBJECTIVES AND LIMITATIONS**

### **1. Thesis Objectives**

The objective of this thesis is to compare the merits of three types of solar cells with respect to the Naval Postgraduate School satellite NPSAT1. Three separate types of solar cells have been considered during the development of this satellite: Silicon, GaAs, and Triple Junction solar cells. The Triple Junction solar cells have been determined to be the cell of choice for the project as they have the highest efficiency and are no cost to the school. This thesis will determine which of the three types of cells can meet the power budget requirements of NPSAT1 and remain within the budget of the program.

### **2. Thesis Limitations**

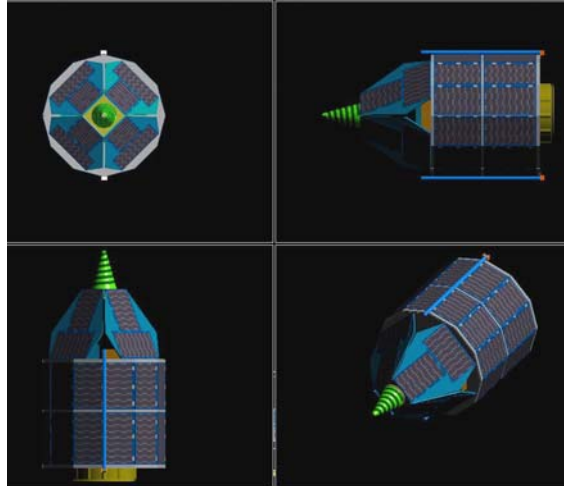
The thesis is limited by several factors involved with the research behind the work. Cost figures from the manufacturer are rarely given unless a prospective buy is taking place. Both the Silicon Cells and the Triple Junction cells were cost free to NPSAT1, but the GaAs cells would not be. The price is not ascertainable, but clearly would be greater than the cost of \$0, that the other sources of solar power provided.

## II. SATELLITE OVERVIEW

### A. MISSION AND EXPERIMENTS

The NPSAT1 satellite has a multi-purpose mission at the Naval Postgraduate School. Among these missions is its use as an educational tool for the resident students and academic researchers. Laden with experimental technology, this platform is also utilized to demonstrate Commercial Off-The-Shelf (COTS) technology on small satellites.

This experimental platform hosts both Naval Research Laboratory (NRL) and NPS experiments. The NRL experiments include a Coherent Electromagnetic Radio Tomography (CERTO) experiment and a Langmuir Probe. A configurable processor experiment, a micro-electromechanical system (MEMS) rate sensor, and a digital camera are among the NPS experiments on-board. Additionally, NPS plans to analyze the performance of triple-junction solar cells in the space environment by taking on-board IV curve measurements. The satellite has a minimum mission life of two years.

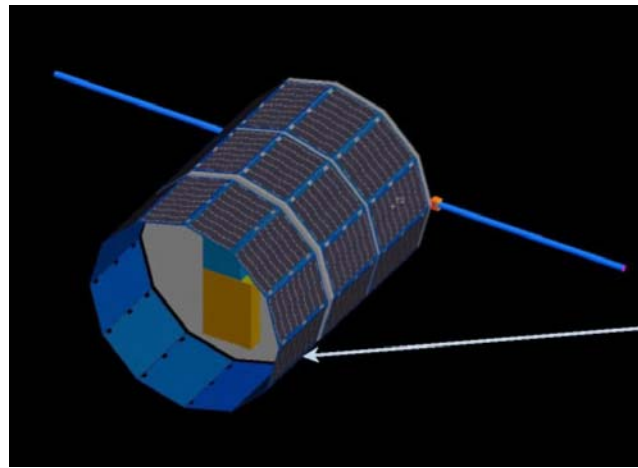


**Figure 1 Older NPSAT1 Design [From Ref. 6].**

### B. NPSAT1 PHYSICAL CHARACTERISTICS

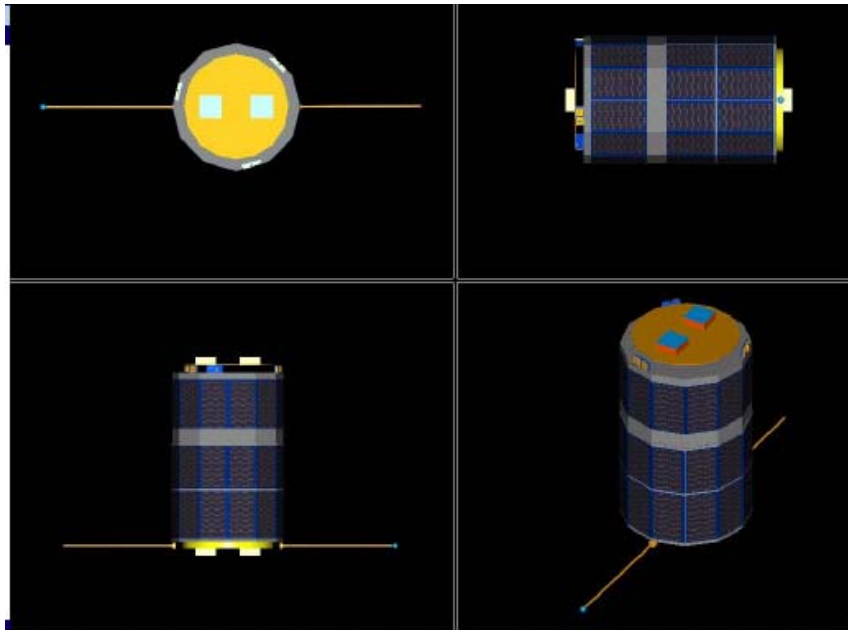
NPSAT1 is approximately 93 cm tall and 50 cm in diameter with a total weight of 81.6 kg (178 lbs). Figure 1 shows an older design of the satellite. There are two sections of 12 solar panels each around the surface of the cylinder and a third set of solar panels

form a cone shape at the end of the satellite. A newer design replaces the pyramid section of solar panels with a third set of solar panels set in the same cylindrical shape as the other two sets, so the satellite will be entirely cylindrical in shape with solar panels covering its circumference as seen in Figure 2. In addition to providing power for the experiments previously mentioned, the power source must provide power for the satellite's internal requirements, including the Attitude Control System (ACS) and the communications system. Full duplex communications will be done in the 1.7-2.2 GHz range (X and S band) using Gaussian Minimum Shift Keying (GMSK) modulation with a data rate of 100 kbps.



**Figure 2 Later NPSAT1 Design [From Ref. 8].**

The latest NPSAT1 design incorporates the 24 test cells that are placed around the body of the spacecraft for the Solar Cell Measurement System (SMS). Two cells are placed on each of the twelve sides of the satellite and will perform current-voltage (IV) curve traces twice per orbit for each illuminated test cell.



**Figure 3 Latest NPSAT1 Design [From Ref. 9].**

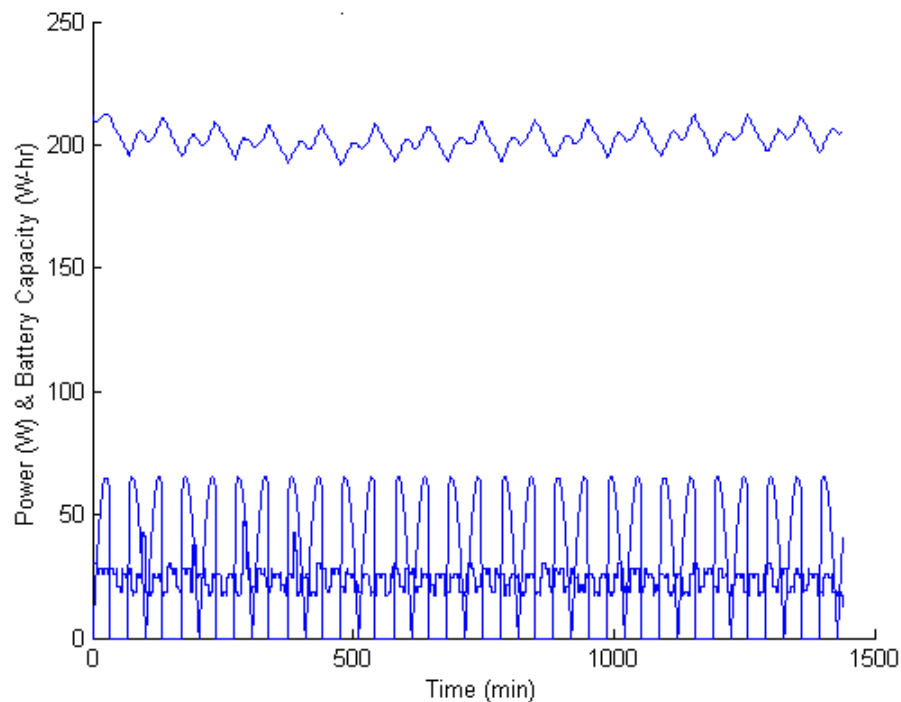
### **C. ORBIT INFORMATION**

NPSAT1 will be inserted into a circular low earth orbit, with an altitude of 560 km and an inclination angle of 35.5 degrees. Without shielding on the solar cells, the satellite will experience approximately  $5 \times 10^{13}$  1MeV electron/cm<sup>2</sup> damage equivalent with the triple junction solar cells. Although this amount of solar radiation will cause some solar cell degradation of the proposed cells, the degradation is too small to warrant adding shielding. The ACS will keep the satellite oriented so that the nadir (bottom) of the satellite is always pointed toward the center of the earth. When not in the eclipse portion of its orbit, the satellite will be within 60 degrees of being normal (perpendicular) to the sunlight.

### III. SOLAR POWER

#### A. SOLAR POWER INPUT

NPSAT1 will travel about the earth at an altitude of 560 km. At this altitude and its inclination of 35.4 degrees, the satellite will experience an average of 30 Watts of power from the sun. Figure 4 displays the solar power and the battery capacity during a 24 hour period of time that NPSAT1 orbits the earth.

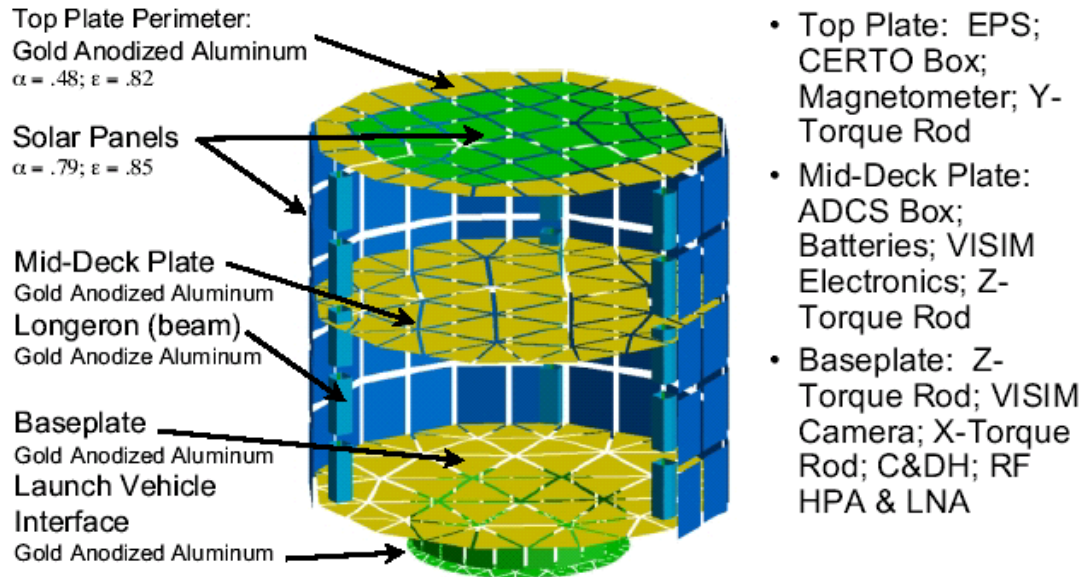


**Figure 4 NPSAT1 Solar Power Input [From Ref. 10].**

#### B. THERMAL TEMPERATURE OF SKIN

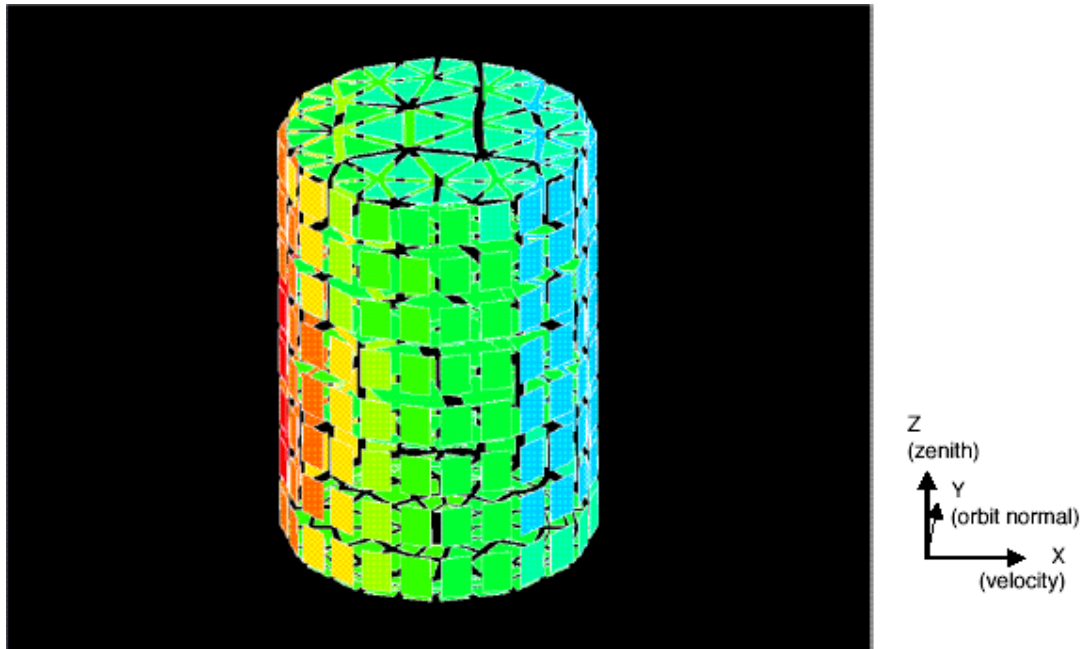
NPSAT1 preliminary thermal analysis results, for the solar panel temperatures on extended cylinder configuration completed 24 October 2001, by Dan Sakoda. The SDRC I-DEAS Thermal Model, which is a finite element model, modeled only the structure, not the internal housing. All material: AL-6061-T6, density:  $2.7658 \times 10^3 \text{ kg/m}^3$ , thermal conductivity:  $1.6788 \times 10^2 \text{ J/m}^\circ\text{K/sec}$ , specific heat:  $9.6296 \times 10^2 \text{ J/kg}^\circ\text{K}$ .

The four equipment plates, gold anodized, have a solar spectrum emissivity of .82, and solar spectrum absorptivity of .48. The solar panels on cylinder sides have a solar spectrum emissivity of .85, and the solar spectrum absorptivity of 79. Although not the extended cylinder, Figure 5 displays the equipment plates on the older model of NPSAT1.

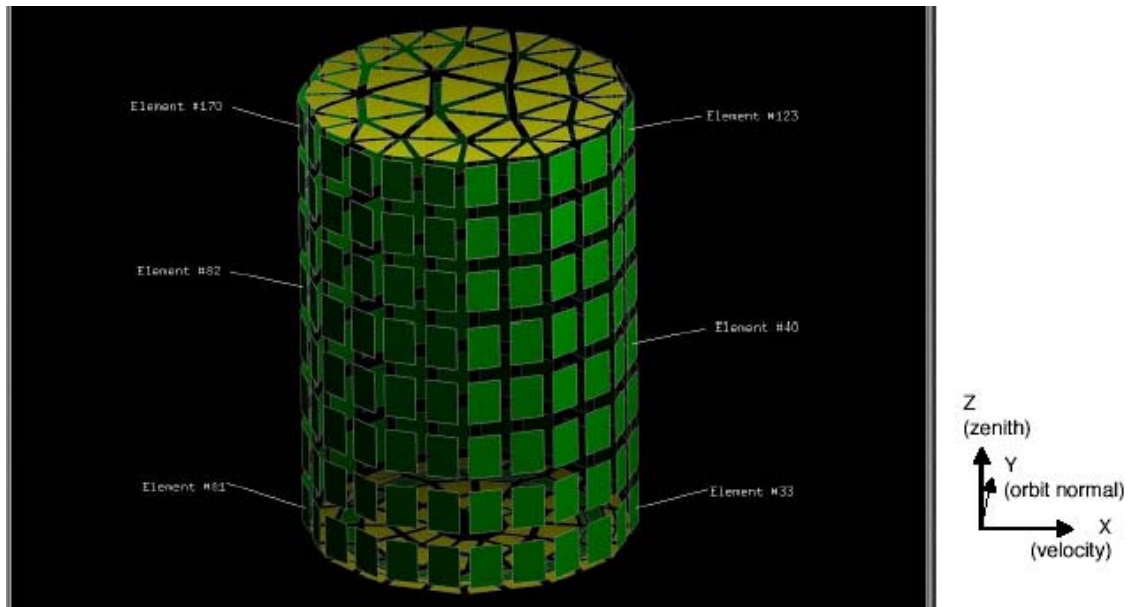


**Figure 5 NPSAT1 Equipment Plates [From Ref. 10].**

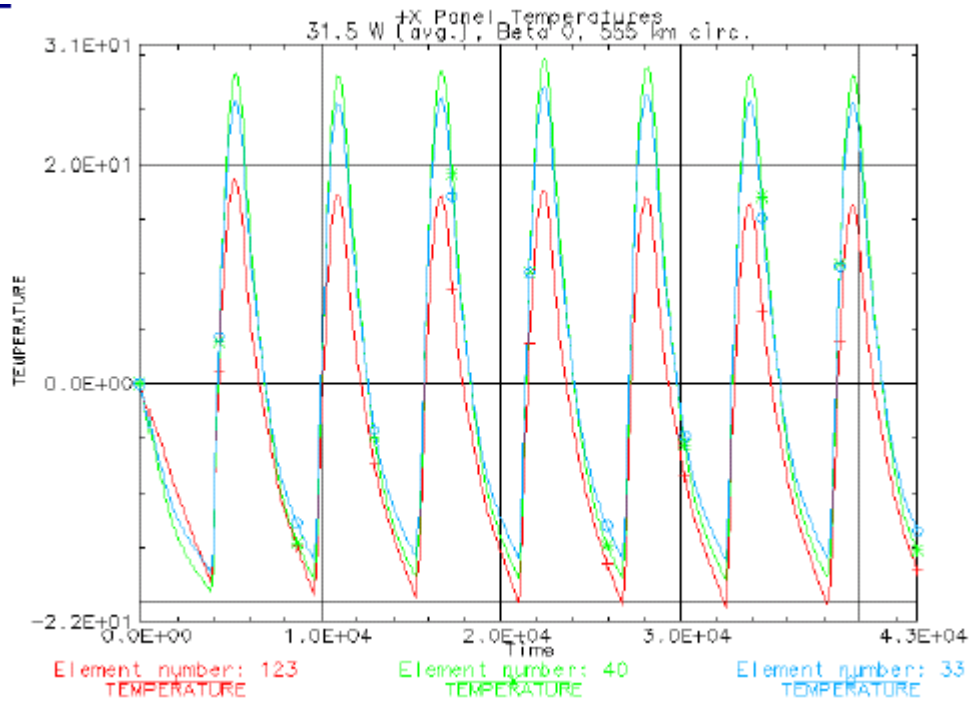
The following figures are the thermal animation results of NPSAT1's thermal analysis. Both animations of the facing panels and recorded temperatures for the various sides of the satellite are present in the following figures.



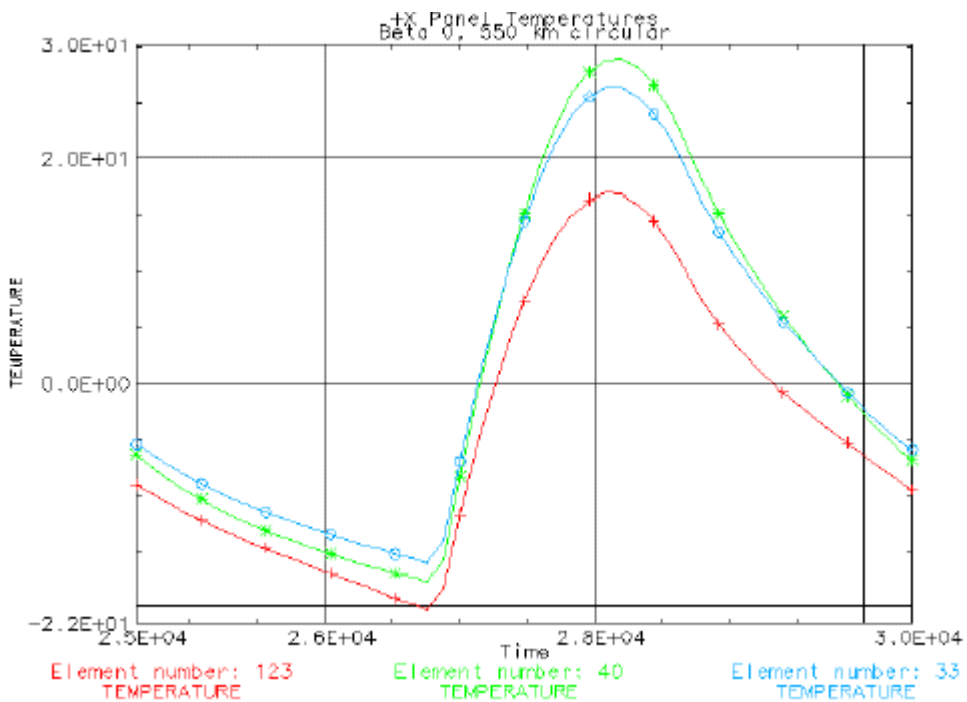
**Figure 6 Thermal Results Animation Still [From Ref. 10].**



**Figure 7 (+/- X) Facing Panels [From Ref. 10].**



**Figure 8 (+X) Facing Panel Temperatures [From Ref. 10].**



**Figure 9 (+X) Panels-Single Orbit [From Ref. 10].**

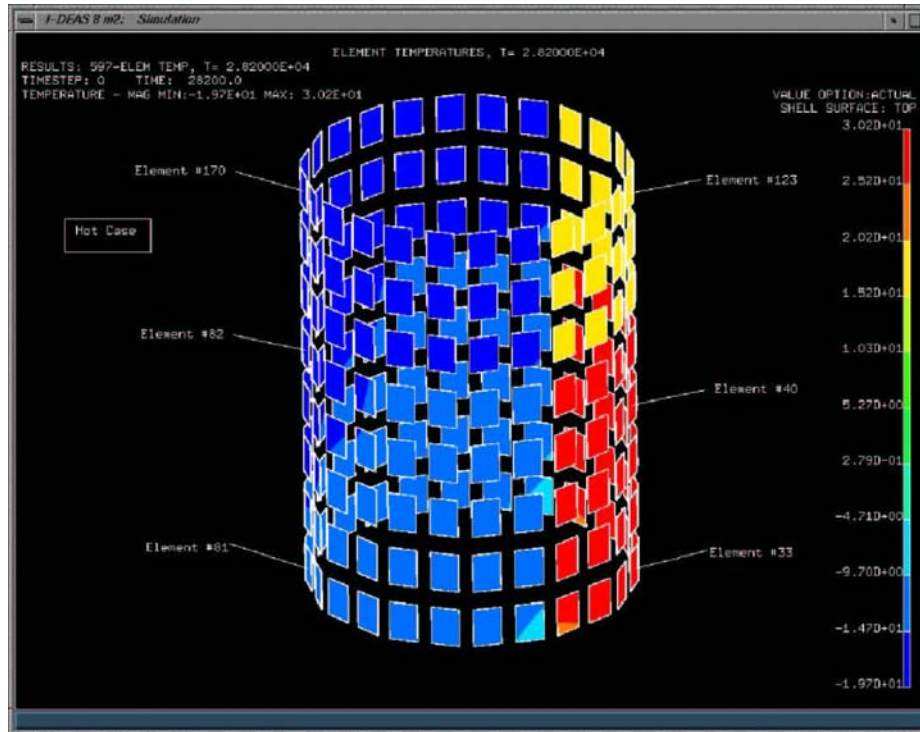


Figure 10 Elements Temperatures Simulation [From Ref. 10].

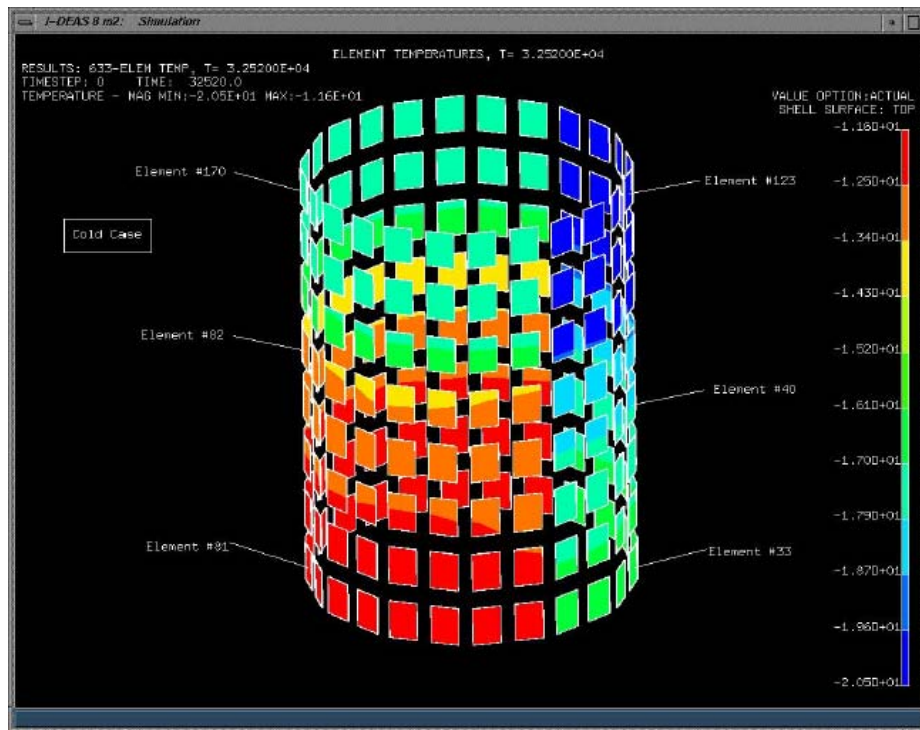
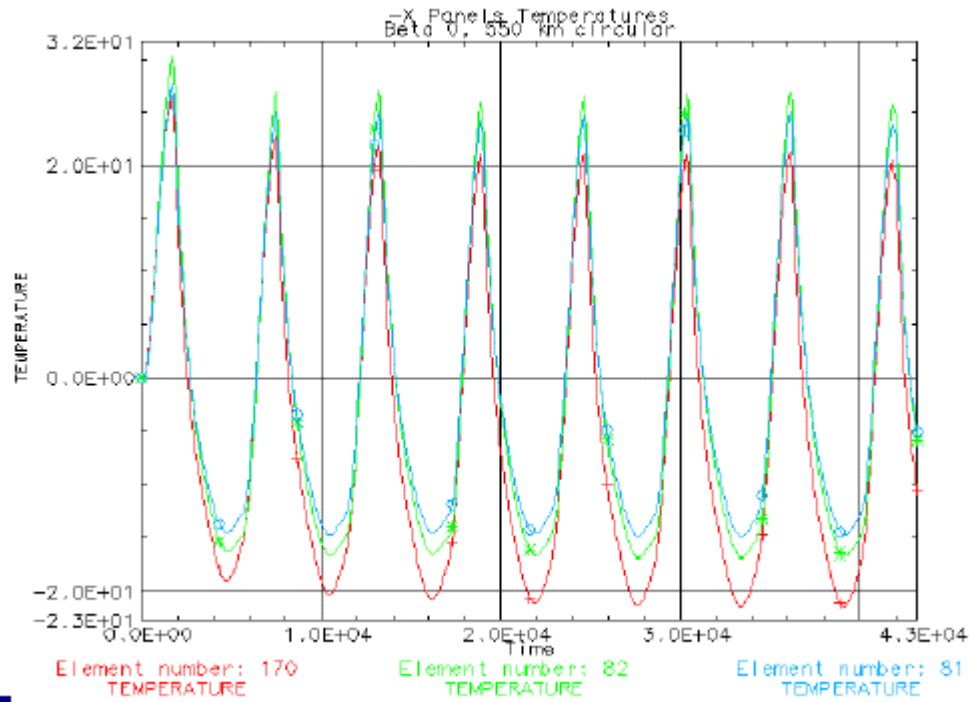
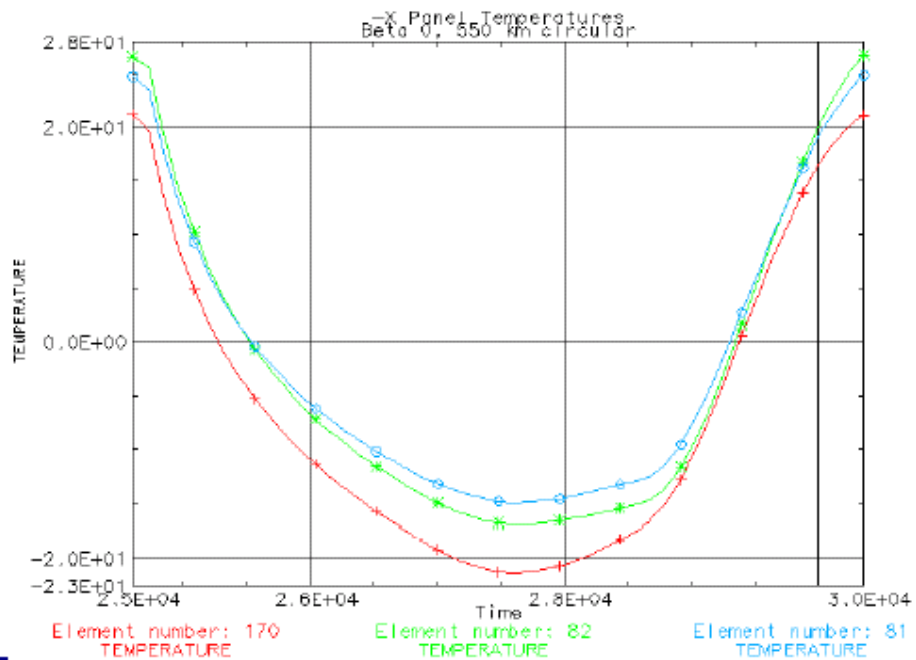


Figure 11 Element Temperatures Simulation [From Ref. 10].



**Figure 12 (-X) Facing Panel Temperatures [From Ref. 10].**



**Figure 13 (-X) Panels Single Orbit [From Ref. 10].**

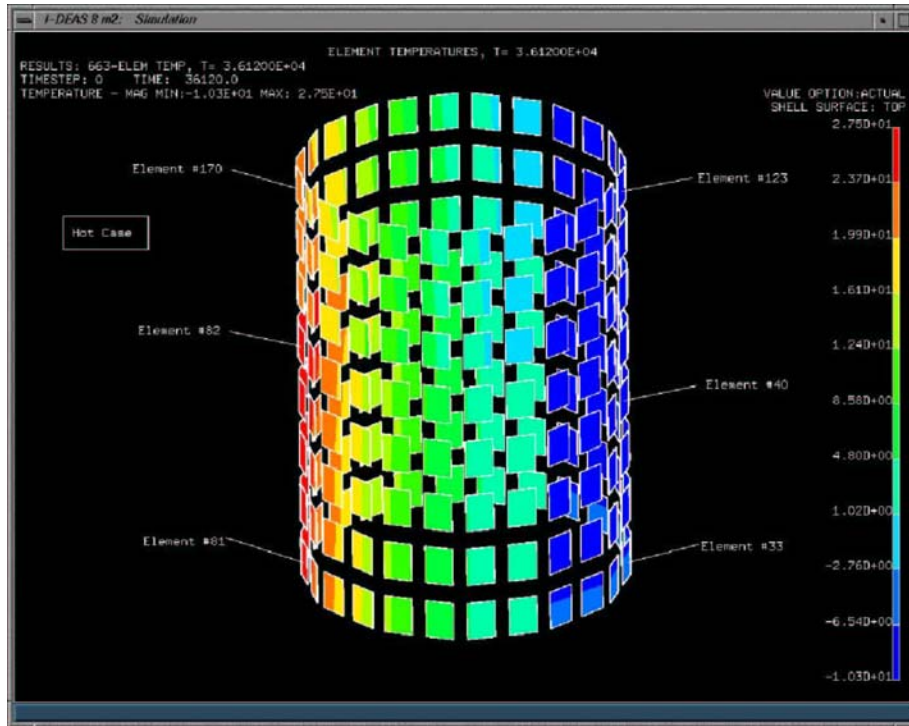


Figure 14 Element Temperatures Simulation [From Ref. 10].

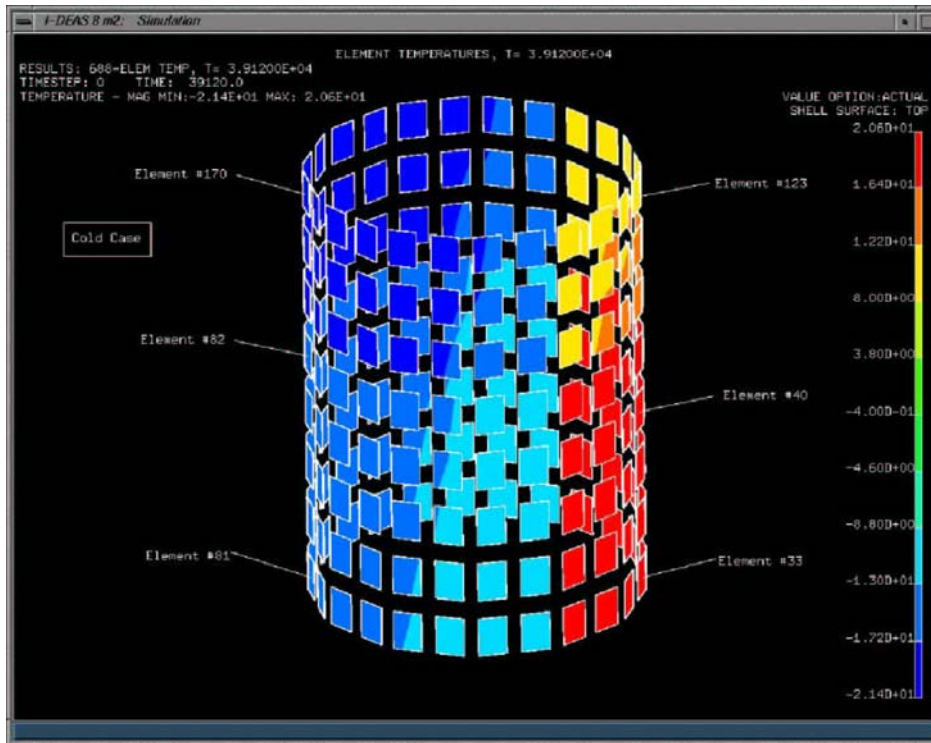
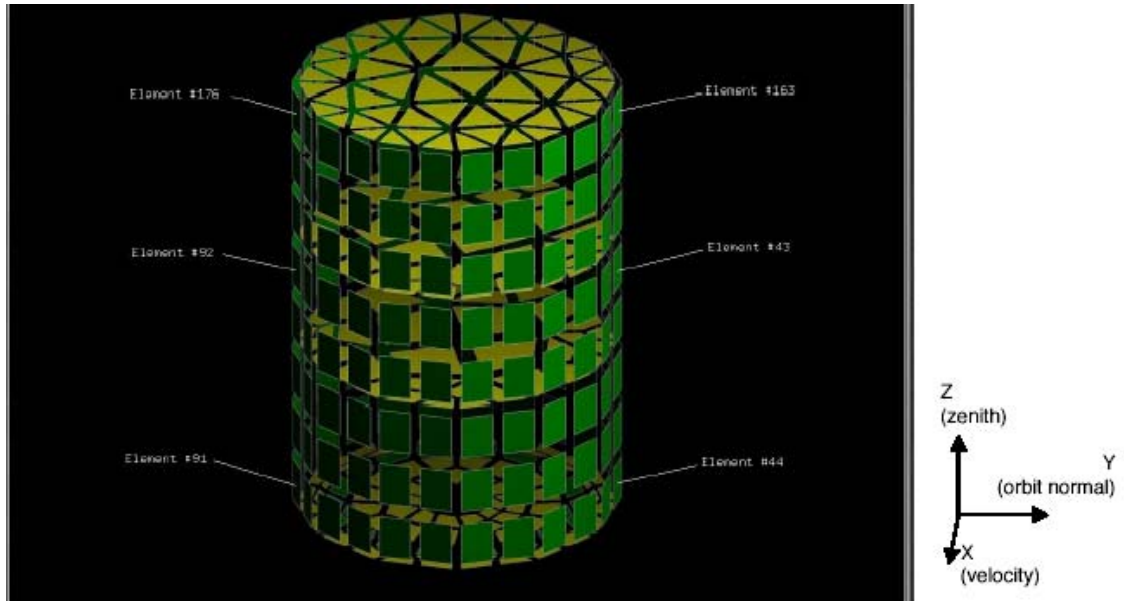
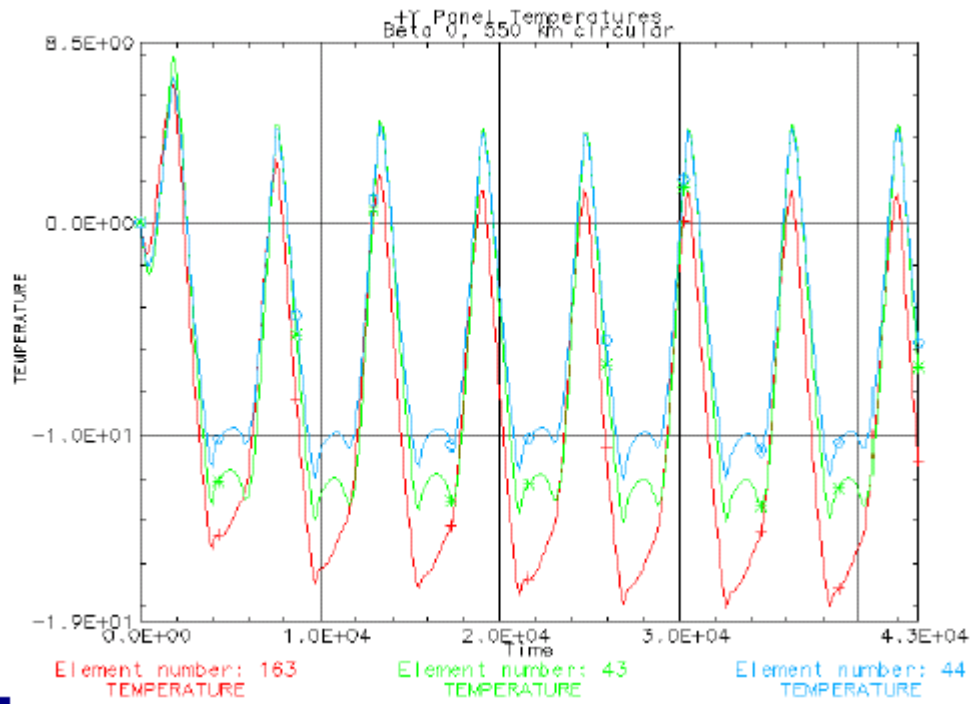


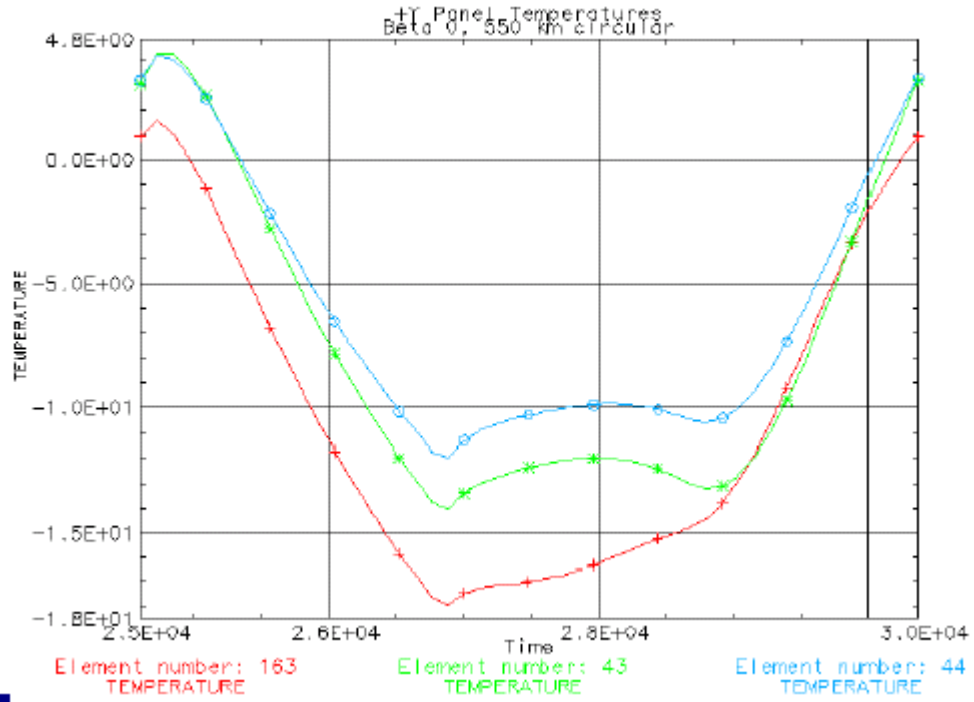
Figure 15 Element Temperatures Simulation [From Ref. 10].



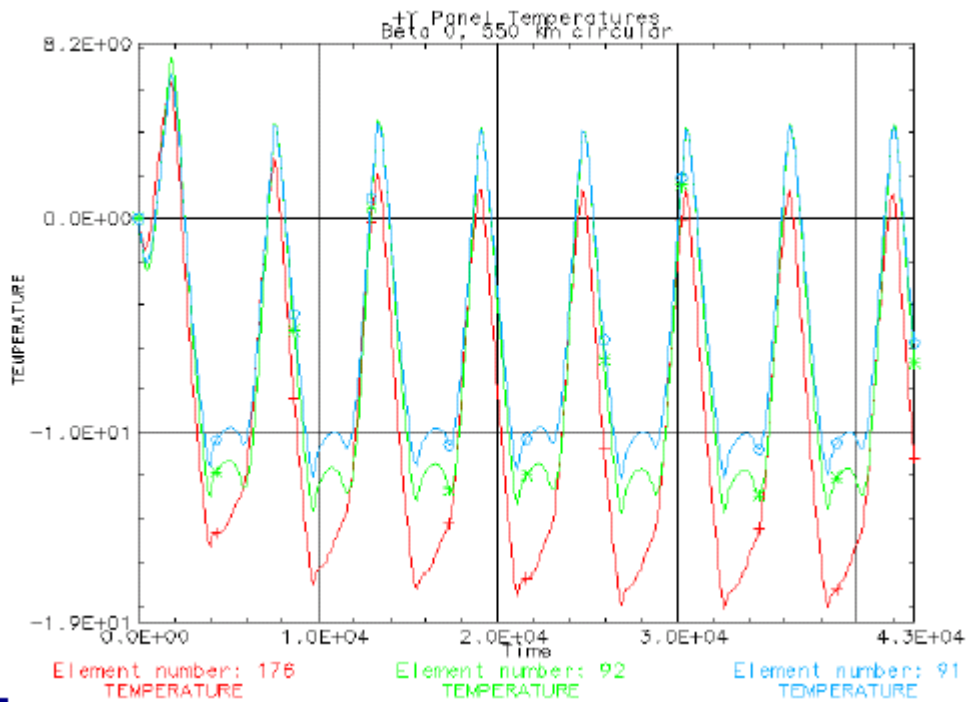
**Figure 16 (+/- Y) Facing Panels [From Ref. 10].**



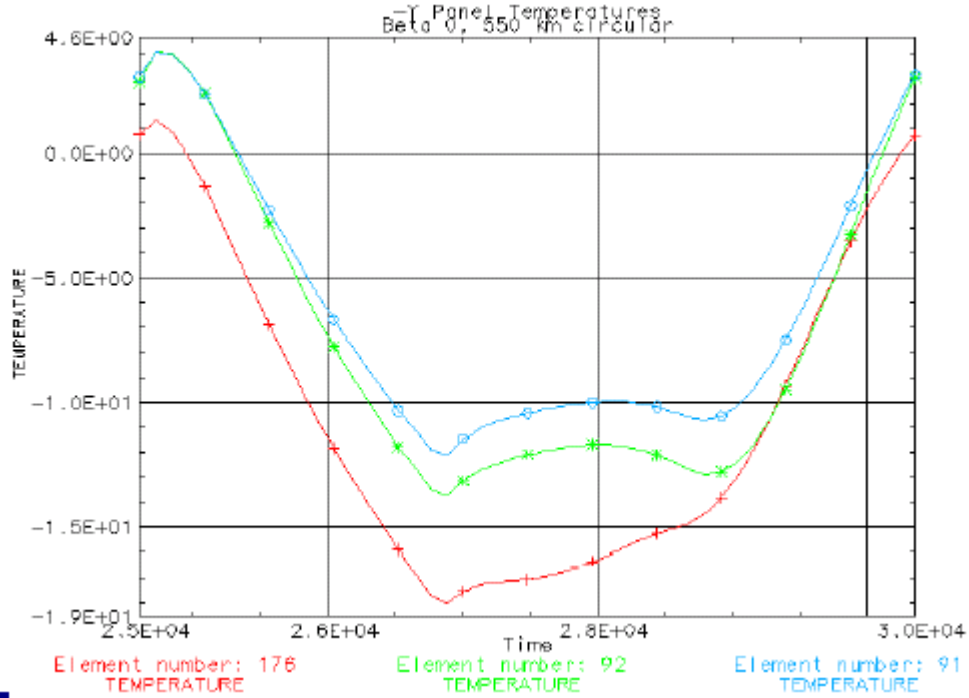
**Figure 17 (+Y) Facing Panel Temperatures [From Ref. 10].**



**Figure 18 (+Y) Panels Single Orbit [From Ref. 10].**



**Figure 19 (-Y) Facing Panels Temperatures [From Ref. 10].**



**Figure 20 (-Y) Panel Temperatures Single Orbit [From Ref. 10].**

The results of the solar temperature simulations demonstrate that the overall range of temperatures is  $-22^{\circ}\text{C}$  to  $+30^{\circ}\text{C}$ . The positive and negative X panels show the most extreme temperatures, with a maximum temperature of less than  $30^{\circ}\text{C}$ , and minimum temperature is greater than  $-22^{\circ}\text{C}$ . The “leading edge” (+X) panels is slightly warmer than (-X) “trailing edge” panels in the simulation. There is no appreciable difference between the positive Y panels and negative Y panels which displayed a maximum temperature of less than  $5^{\circ}\text{C}$ , and a minimum temperature of greater than  $-19^{\circ}\text{C}$ .

THIS PAGE INTENTIONALLY LEFT BLANK

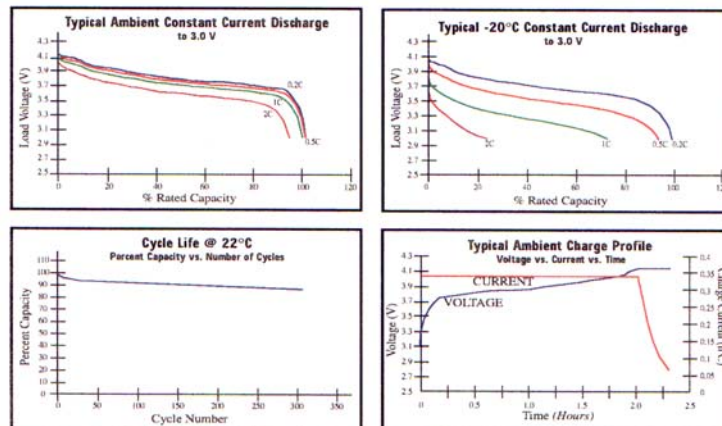
## **IV. PAYLOAD POWER BUDGET**

### **A. EXPERIMENTS**

A primary NPSAT1 mission is to test a variety of COTS technologies. The command and data handling (C&DH) subsystem uses a PC/104-based architecture and a COTS operating system, Linux. Configurable Processor Experiment (CPE) is a Naval Postgraduate School experiment. The experiment consists of a single electronic circuit board that is housed within the C&DH. It interfaces with the C&DH motherboard via the PC/104 bus for power, digital control, and data. This C&DH architecture is completely compatible with the desktop PC in a miniaturized configuration. Combining the PC/104 hardware and the Linux operating system allows for software development at a desktop PC that will be compatible with the target flight hardware.

This satellite will also demonstrate ferroelectric (FERRO) memory which is a COTS technology directly applicable to space. FERRO RAM devices are currently available and offer radiation-tolerance and non-volatile memory storage. NPSAT1 will utilize the FERRO RAM as part of the electrical power subsystem (EPS).

Lithium-ion rechargeable batteries are another example of COTS technology that is advantageous for space use and will be on-board NPSAT1. Li-ion batteries offer the highest energy density (Watt-hours per kilogram) than any of the battery technologies currently used in space. NPSAT1 is considering the use of a Li-ion polymer battery which provides a safe battery cell with regard to overcharging, discharging and handling damage. Figure 21 displays the cycle life of the Li-ion battery and the current discharge and charge curves, whereas Figure 22 provides more detailed data on the UBC493483 battery manufactured by Ultralife Batteries Inc.



**Figure 21 Li-ion Battery Charge/Discharge Tables [From Ref. 13].**

### UBC493483

System:	Polymer Rechargeable
Voltage Range:	4.20 to 3.0 Volts
Average Voltage:	3.8 Volts
Nominal Capacity :	900 mAh @ C/5 Rate
Max. Discharge:	2C Continuous; 5C Pulse
Energy:	3.4 Wh
Energy Density:	118 Wh/kg 260 Wh/l
Weight:	29 grams
Cycle Life:	>300 Cycles @C/2 to 80% of initial capacity
Memory:	No Memory Effect
Operating Temp.:	-20°C to +60°C
Storage Temp.:	-20°C to +60°C
Self-Discharge:	<10% Per Month
Terminals:	Al (+), Ni (-)
Jacket:	Laminated Foil

**Figure 22 Li-ion Battery Data Table [From Ref. 13].**

The Naval Postgraduate School will also be testing a Visible Wavelength Imager (VISIM) while on orbit. VISIM is a COTS digital camera that is operated by a COTS single board computer. The CCD controller is a PC/104 board that is a 486 running at 66 MHz supporting the PC/104 bus. The single-board computer requires 2.5 W, as does the CCD and controller combined. This unit will be powered off during flight until the period of time when the satellite passes over the area of interest.

Two experiments will be provided by the Naval Research Laboratory (NRL). These include the coherent electromagnetic radio tomography (CERTO) experiment, which is a three-frequency beacon, and a Langmuir probe. The CERTO probe is a radio beacon that transmits at three frequencies: 150, 400, and 1067 MHz. The experiment deals with a space-based beacon and a network of ground receivers that will measure the integrated electron density of the ionosphere in the plane of observation. This experiment may also be used to correct for ionospheric refraction that limits space-based geolocation of ground transmitters, and also measures the scintillation environment that degrades military system performance. CERTO's other testing objectives will be to perform scintillation studies of the ionosphere; to characterize the ionosphere for geolocation; to develop and test tomographic algorithms for reconstruction of ionospheric irregularities; and to provide a database for global models of the ionosphere. When the Langmuir probe is enabled, it produces four analog outputs: electron density, electron fluctuations, ion density and ion fluctuations. The A/D on the C&DH converts these analog inputs using a 12-bit digital conversion at a sampling rate between 10 and 1000 samples/sec.

The Solar Cell Measurement System (SMS) is the final experiment added to the NPSAT1 project. The experiment consists of 24 triple-junction cells provided from Spectrolab, placed around the body of the spacecraft. The SMS will perform current-voltage (IV) curve traces for each illuminated test cell twice per orbit. Each test cell will provide fifty test points per IV curve. The temperatures for each test cell, the open circuit voltage, the short circuit current, and the maximum power points will all be collected during this experiment. This experiment also includes six sun sensor modules to provide 360° field-of-view in azimuth and +/- 64° in elevation. The sun sensor modules are model 13-515 double triangles made by BF Goodrich. The layout of this experiment and the other NPSAT1 experiments can be seen in Figure 23.

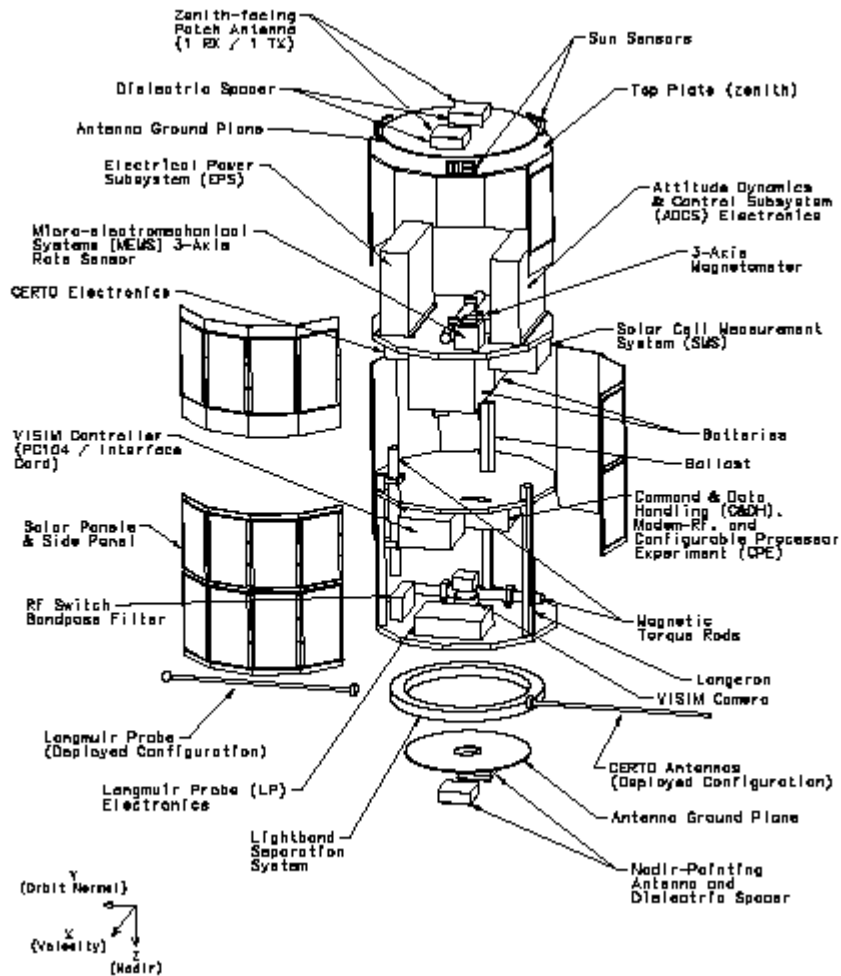


Figure 23 Experiment Layout on NPSAT1 [From Ref. 9].

## B. ESTIMATED POWER REQUIREMENTS

NPSAT1 is expecting to receive limited solar panel power output. Duty-cycling of the satellite's sub-systems is required to budget the power requirements of all the experiments on board. The average power requirement for the payloads is 274.87 W-hr/day, calculated by adding the average power column in Table 1. The T&C subsystem of the satellite requires four 5-minute passes which equates to 9.33 W-hr/day. The experiments alone necessitate 108.83 W-hr/day. The VISIM project needs 10.21 W-hr/day and the Configurable Processor Experiment (CPE) consumes 24.03 W-hr/day. The SMS system will require only 2.03 W-hr/day as it only operates while in sunlight. CERTO will then consume the remaining allotment of 54.98 W-hr/day. Table 1 further

illuminates the power requirements of the satellite system. The Langmuir Probe requires average power of 10.21 W-hr/day.

**Table 1 Estimated NPSAT1 Power Budget [From Ref. 9].**

**Table 1. Estimated NPSAT1 Power Budget.**

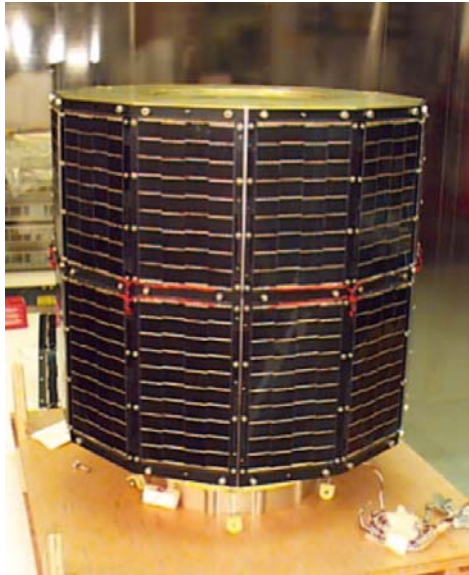
Subsystem / Component	Duty Cycle (%)	Avg. Power (W)	Avg. Energy/Orbit (W-hr)
<b>EPS Processor Board</b>	50	.75	1.20
Switch Board A/D	50	.03	.05
Switch Board DAC	50	.03	.05
Switches	100	.50	.80
<b>ACS Torque Rods</b>	50	.02	.02
Processor Board	50	.75	1.2
Magnetometer	10	.14	.22
MEMS	1	.02	.04
<b>C&amp;DH 386 Core</b>	50	.80	1.28
EDAC RAM	25	1.02	1.63
SCC	100	.08	0.13
UART	100	.23	0.37
FPGA	100	.25	0.40
Solid State Disk	50	.15	0.24
A/D	100	2.05	3.27
<b>RFS TX/RX</b>	2	.30	.48
LO (& modem)	3	.09	.14
<b>SMS (only operates in sunlight)</b>			
Processor Board	5	.12	.12
Switch Board A/D	5	.01	.01
Switch Board DAC	5	.005	.005
<b>CERTO Standby</b>	12.5	.43	.69
150/400 MHz mode	20	1.53	2.43
1067 MHz mode	6.6	.34	.54
Langmuir probe	<b>26.5</b>	<b>.42</b>	<b>.68</b>
<b>Configurable Processor Exp.</b>	25	1.00	1.60
<b>VISIM (only operates in sunlight)</b>	8.5	.68	.68
<b>Total Average Energy per Orbit</b>			<b>18.3</b>
<b>Solar Panel Energy (75% eff.)</b>			<b>21.2</b>
<b>Margin (W-hr)</b>			<b>3.0</b>

THIS PAGE LEFT INTENTIONALLY BLANK

## V. SILICON CELLS

### A. NPSAT1 SILICON PROSPECTIVE CELLS

The silicon solar cells which NPSAT1 was originally going to use were left over cells from a previously canceled Navy small satellite program. There were enough cells remaining to cover the entire twelve-sided body of NPSAT1. Figure 24 shows the silicon solar panel layout on the original NPSAT1 design which did not include the third level of solar cells. Although there were enough cells to cover two-thirds of the body for the final design, there are not enough to completely cover the third level and some would therefore need to be purchased to satisfy this design.



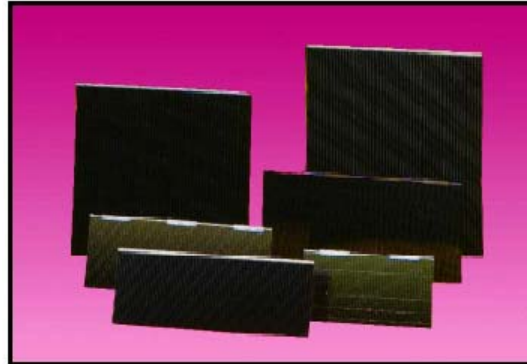
**Figure 24 NPSAT1 Adorned With Silicon Solar Panels on Incomplete Body [From Ref. 6].**

The existing panels for NPSAT1 have the 2.64 cm x 1.93 cm silicon cells, in an arrangement of 76 cells per series string. The layout would consist of two panels per cylinder side per string. They are mounted on the cylinder panel, incorporating four segments of the 12-sided cylinder.

The panel layout constraints include the fastener locations for the structural panel and the fastener locations for the solar panels. With these limitations, the two sizes of cells 4 x 10 cells and 4 x 9 cells were applied.

Using the data from Spectrolab's Silicon K6700B Solar Cells, we are able to calculate the approximate power output that these cells would provide NPSAT1. These

cell's features include high conversion efficiency, high state-of the art reliability, optimized operating temperature and hardened applications. The hardened applications include protection from some space environmental effects, both for military and commercial, for terrestrial power and for consumer products. As seen in figure 27, Spectrolab offers a variety of sizes for their Silicon Cells.

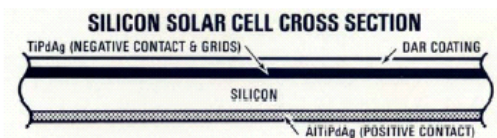


**Figure 25 Silicon K6700B Solar Cells [From Ref. 11].**

Spectrolab offers a great deal of information with regard to these solar cells and provides product descriptions as seen in Figure 26, and typical qualification test results are also viewable in Figure 26.

<b>Product Description</b>	
Standard/Special Product	Standard
Resistivity (p-type)	10 Ohm-cm
Crystal Orientation	1 - 0 - 0
Method of Growth	Czochralski
Shallow Junction	0.15 Micron
Metallization (Front)	TiPdAg
Metallization (Back)	AlTiPdAg
Anti-Reflective Coating	Multi-Layer
Back Surface Reflector	Aluminum
Back Surface Field	Boron
Sculptured Front Surface	No
Thickness	62 Microns
Sizes	Up to 8x8 cm
Weldable	Yes
Solderable	Sn62 Solder (QQ-S-571)
Note: other variations are available upon request	
The information contained on this sheet is for reference only. Specifications subject to change without notice. 01/17/2000	

<b>Typical Qualification Test Results</b>		
<b>Nominal Degradation</b>		
Test	Description	Results
Humidity	+45°C, 90% RH Min., 30 Days	<1.5%
Thermal Cycle	+80°C to -180°C, 3000 Cycles	<2.5%
Thermal Shock	+140°C to -185°C, 5 Cycles	<1.5%
Thermal Soak	+140°C for 168 Hrs., 5x10 <sup>-5</sup> torr	<1.5%
Radiation	Characterized thru 1x10 <sup>16</sup> 1 MeV e/cm <sup>2</sup>	---
Pull Test	90° Pull, Standard Tab	>250 gm



**Figure 26 Product Description [From Ref. 11].**

Spectrolab's electrical data provided for this silicon cell suggests the following parameters at maximum power: current = 37.0 milliAmperes/cm<sup>2</sup>, voltage = .500 Volts, power = 18.5 milliWatts/cm<sup>2</sup>. The efficiency is advertised to be 13.7% minimum average. Figure 27 displays this cell's typical I-V curve at AM0.

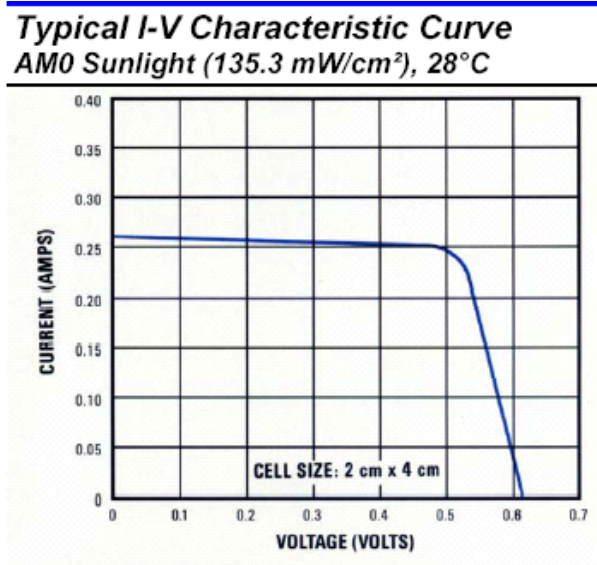


Figure 27 Silicon I-V Curve [From Ref. 11].

## B. TEST CELLS AND PROCEDURES

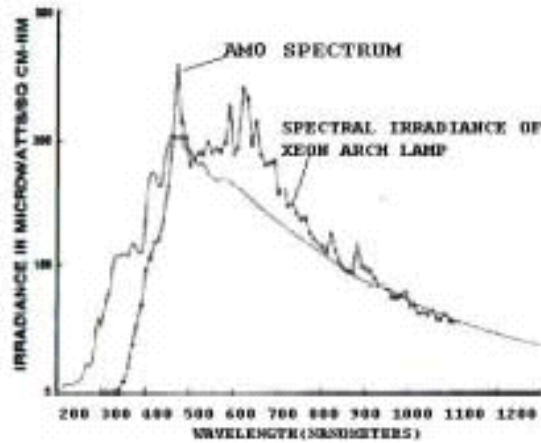
### 1. Background

In order to assess the accuracy of the manufacturer's data that has been provided, this thesis will give example cell testing that was performed at the Naval Postgraduate School's solar simulator lab and then the LINAC by a fellow student. LT Michael Woods, United States Navy has provided the following test data for a similar silicon cell.

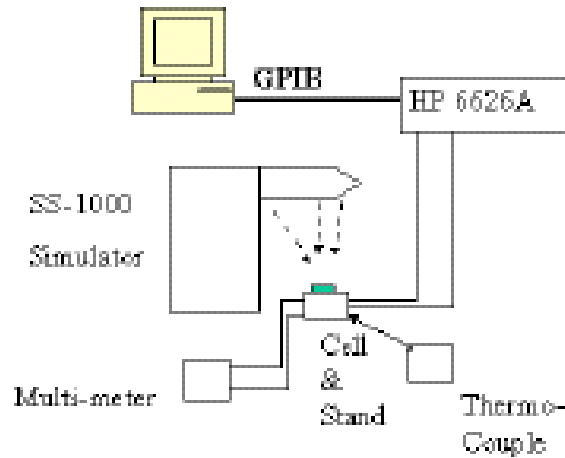
### 2. Solar Simulator Testing

The following detailed information about the solar simulator has been extracted in part from a 2001 NPS thesis entitled, *Radiation Effects on Multi-junction Solar Cells*, by Tommy L. Fifer. The Naval Postgraduate School's solar simulator is an Optical Radiation Corporation Model SS-1000. This simulator uses a xenon bulb which closely resembles the spectral distribution of sun light under AM0 conditions as seen in Figure

28. The entire system consists of the SS-1000, a vacuum assisted/temperature controlled brass test block, a Hewlett-Packard programmable power supply (HP 6626A), and a personal computer with an HP-IB interface card running LABVIEW software. Figure 29 shows the experimental set-up.



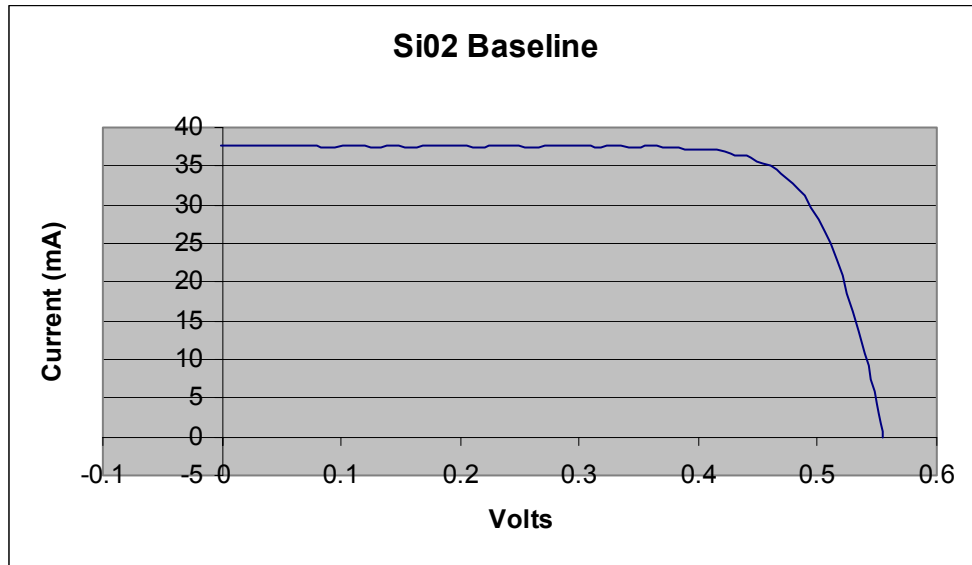
**Figure 28 Xenon Arc Lamp and the Sun's Spectrum at AM0 Conditions [From Ref. 2].**



**Figure 29 Solar Simulation Set-up [From Ref. 2].**

With the use of the solar simulator, LT Woods was able to do calibration tests on the silicon cells to determine what the efficiency of the cells would be prior to radiation testing. The following IV curve is representative of the base-line curves performed on

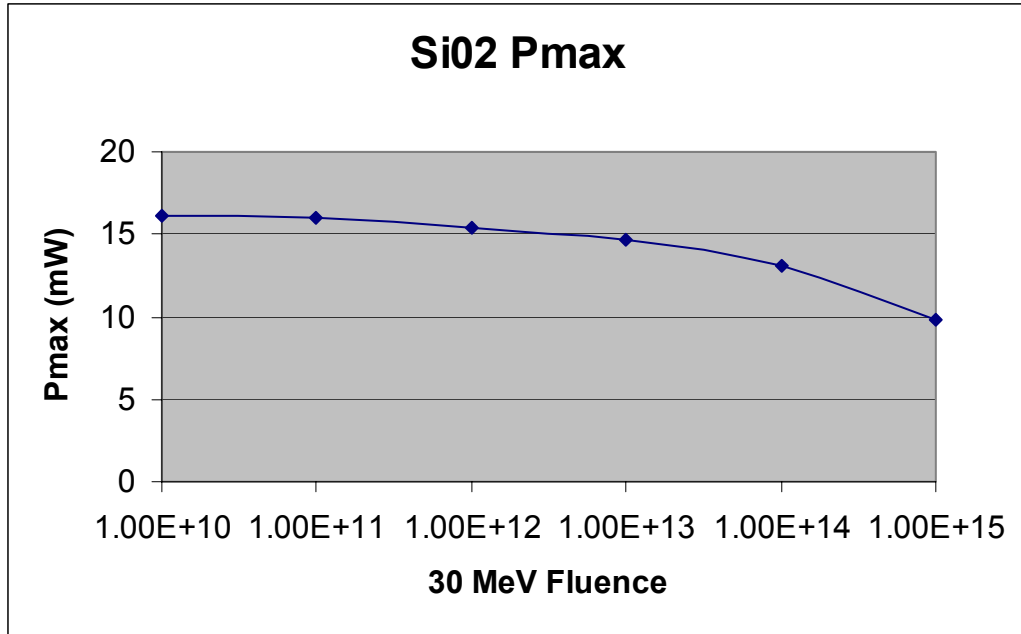
the silicon cells. The results of the silicon efficiency testing was determined to be approximately 14% prior to radiation testing.



**Figure 30 Silicon Cell Base-line IV Curve [From Ref. 15].**

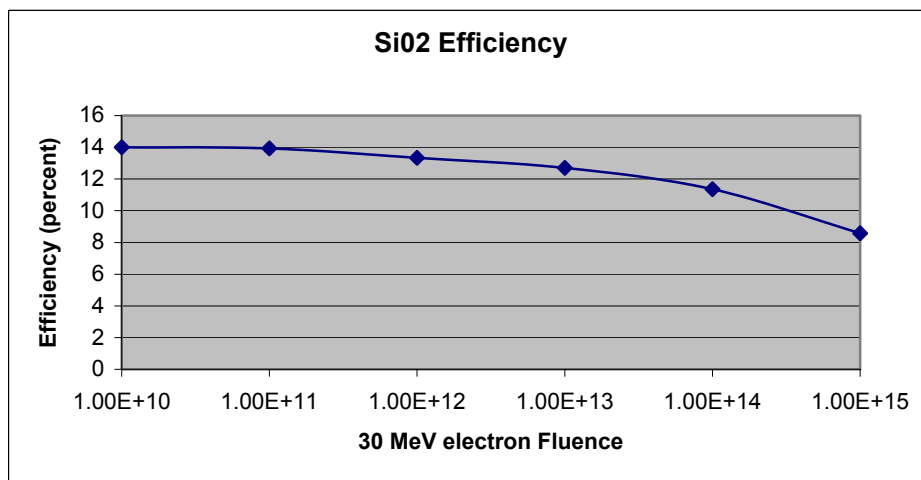
### **3. LINAC Testing**

The NPS LINAC (Linear Accelerator) was used to irradiate the silicon cells via accelerated electrons. The density profile of the electron beam in the LINAC is Gaussian. Because of the nature of the beam, the electron distribution can be determined. This is determined by a digitized beam profile generated from the beam striking a phosphorous screen, not the target. The standard dose for assessing electron damage to a solar cell is a fluence of  $1 \times 10^{15}$  electrons/cm<sup>2</sup>. The resulting degradation to cell output power is appreciable, as seen in Figure 31.



**Figure 31 Silicon Cell Pmax during LINAC Testing [From Ref. 15].**

There is also an appreciable difference in the efficiency of the radiated cell over a period of time as visible in Figure 32. The efficiency of the silicon cell dropped from 14 percent efficient to 8.557 percent efficient with doses of up to  $1 \times 10^{15}$  30 MeV electrons/cm<sup>2</sup>.



**Figure 32 Silicon Cell LINAC Testing Efficiency Results [From Ref. 15].**

The short circuit current output and open circuit voltage output were degraded over the course of irradiation as well, seen in Figures 33 and 34. Figure 33 shows that the maximum current dropped from 35 mA/cm<sup>2</sup> to 25. Open circuit voltage was similarly degraded as demonstrated by Figure 34, dropping from .56V to 0.5V.

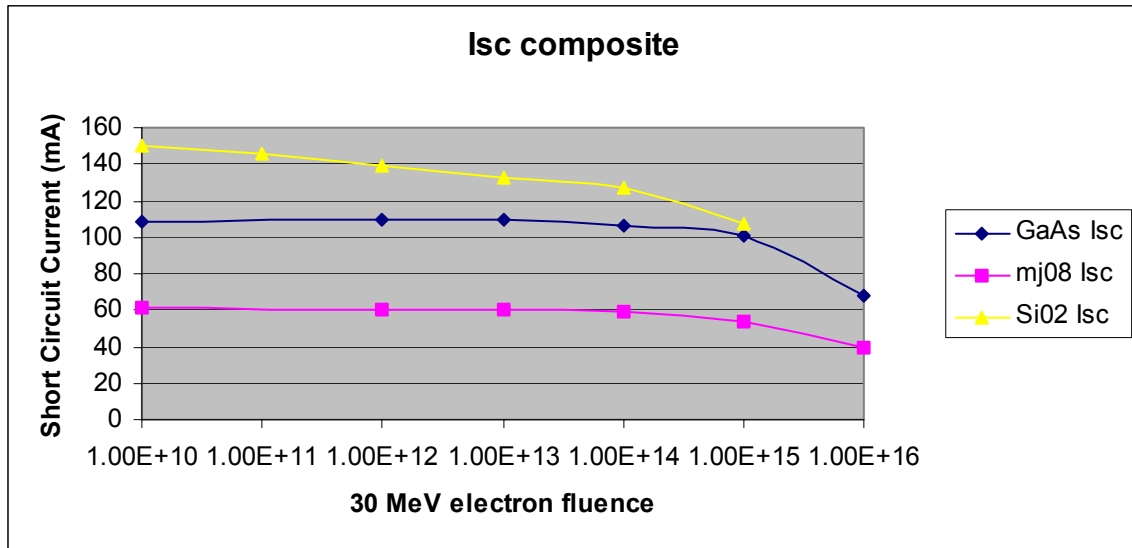


Figure 33 Composite LINAC Testing Isc Results [From Ref. 15].

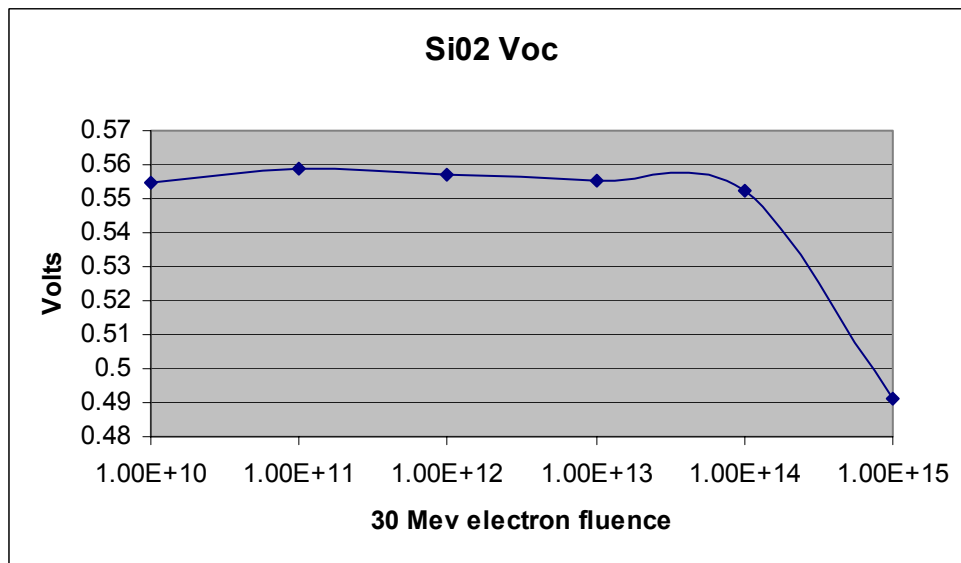
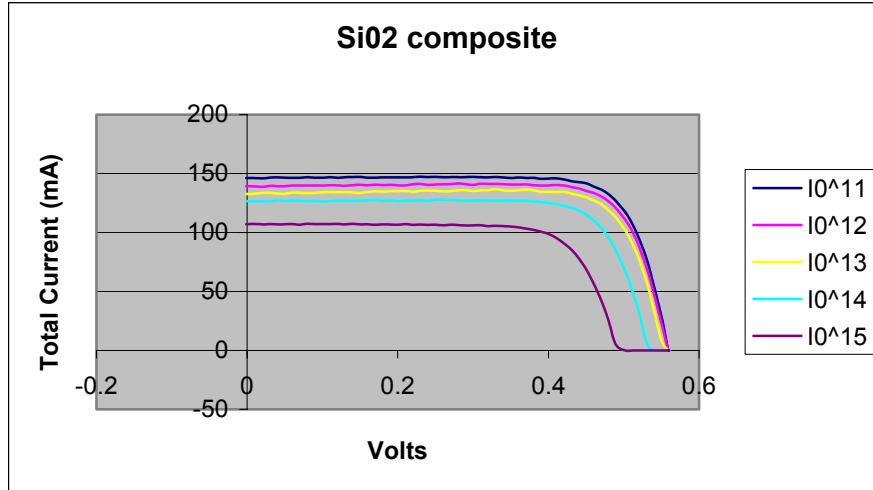


Figure 34 Silicon Cell LINAC Testing Voc Results [From Ref. 15].



**Figure 35 Silicon Cell LINAC Radiation Composite Curves [After Ref 15].**

### C. FINDINGS

In order to determine the maximum power output for NPSAT1 using the silicon cells in comparison to the decided upon triple junction cells, the same cell layout and number of cells will be used. Based on this cell layout and electrical characteristics of the Silicon K6700B Solar cell, the maximum output power for NPSAT1 is determined as follows:

$$A_{\text{eff}} = 2 * \text{radius} * \text{length}$$

$$\text{SatelliteRadius} = 25\text{cm}$$

$$\text{Large Panel Cell Density} = 72.6\%$$

$$\text{Small Panel Cell Density} = 60.8\%$$

$$\text{Large Panel Length} = 2 * 21.27\text{cm} = 42.54\text{cm}$$

$$\text{Large Panel Effective Area} = 2 * 25 * 42.54 * (0.726) = 1544.20 \text{ sqcm}$$

$$\text{Small Panel Length} = 19.05 \text{ cm}$$

$$\text{Small Panel Effective Area} = 2 * 25 * 19.05 * (0.608) = 579.12 \text{ sqcm}$$

$$\text{Total Effective Area} = 2123.32 \text{ sqcm}$$

$$\text{Voltage (max power)} = .500 \text{ V}$$

$$\text{Current (max power)} = 37.0 \text{ mA/sqcm}$$

$$\text{Maximum Power/Cell} = 18.5 \text{ mW/sqcm}$$

$$P_{\text{max(BOL)}} = 18.5 \text{ mW/sqcm} * 2123.32 \text{ sqcm} = 39.281 \text{ W}$$

The Beginning Of Life (BOL) maximum power figure is possible when the satellite is normal to the sun; however, the satellite's angle relative to the sun will vary over its orbit. Normal to the sun in this case is when a solar panel is perpendicular to the sun's rays. The angle between the spacecraft's orbit plane and the sun is called the beta angle which for 0 degrees corresponds to the sun located in the orbit plane. For beta angle 0 degrees, the spacecraft has both the case of maximum power with the sun vector normal to the cylinder side, and the minimum case with the cylinder end facing the sun. For the purposes of comparison, a range of power output values is taken for the case of full, direct sunlight on the cylinder sides and that of the sun 60 degrees from the normal. As the long axis of the satellite changes angle from 90 degrees to the sun's rays, the maximum power output drops as a function of the cosine of the angle. When the satellite is not in an eclipse the solar array provides power in the range from as low as 19.6 to 39.3 W.

<b>Radiation Degradation</b> <b>(Fluence e/cm<sup>2</sup> 1 MeV Electrons)</b>				
Parameter	1x10 <sup>14</sup>	5x10 <sup>14</sup>	1x10 <sup>15</sup>	2.5x10 <sup>15</sup>
Isc/Isc <sub>0</sub>	0.98	0.94	0.91	0.86
Imp/Imp <sub>0</sub>	0.98	0.93	0.90	0.85
Vmp/Vmp <sub>0</sub>	0.94	0.88	0.85	0.82
Voc/Voc <sub>0</sub>	0.96	0.90	0.87	0.82
Pmp/Pmp <sub>0</sub>	0.92	0.82	0.77	0.70

**Figure 36 Manufacturer's Radiation Data on Silicon Cell [From Ref. 11].**

NPSAT1 will orbit the earth at an altitude of 560 kilometers and an inclination of 35.4 degrees. Based upon the orbit information and the two-year mission life of the satellite, the total accumulated radiation dose needs to be determined. Using the *Solar Cell Radiation Handbook*, equivalent fluences were determined assuming 12 mil shielding.

Electron Fluence = 3.32e+11

Proton Fluence = 8.76e+12

Total Fluence = 8.793e+12

From the electrical characteristic data of the silicon and the *Solar Cell Radiation Handbook*, a fluence of 1e+13 will cause a 4.3 percent reduction in the maximum power output of the solar cell. Because the total fluence expected for NPSAT1 is roughly 88 percent of this amount, the silicon solar cells will suffer a power reduction of approximately 3.78 percent. The maximum output power available at the End Of Life (EOL) for NPSAT1 is calculated by reducing the beginning of life power by 3.78 percent.

$$P_{\max(\text{EOL})} = P_{\max(\text{BOL})} * .9625 = 38.8\text{W}$$

The EOL power output of between 18.86 W and 38.8 W is adequate for fulfilling NPSAT1's average power need of 18-20 W and also meets the need for the max power output of 27W during transmission times to earth without the need to rely on batteries.

According to the radiation testing with the LINAC with special regard to Figure 30, the actual degradation with a 30 MeV Electron Fluence is closer to 9.3 percent. This appreciable difference can be explained by the fact that the manufacturer's data is based on radiation of 1 MeV Electron Fluence, whereas the LINAC tests at 30 MeV Electron Fluence. The difference in degradation also marks a change in the EOL power that these cells could provide.

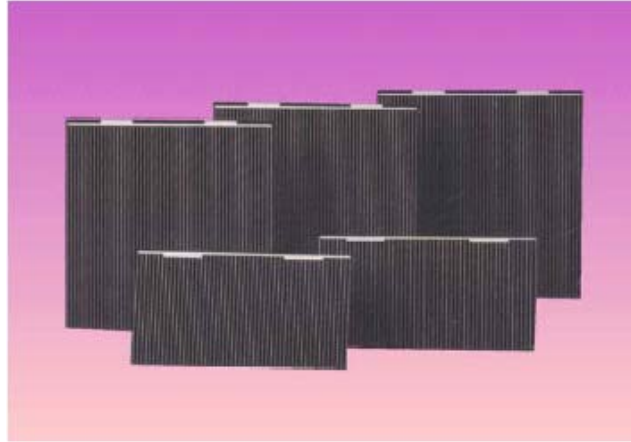
$$P_{\max(\text{EOL})} = P_{\max(\text{BOL})} * .907 = 35.64\text{W}$$

An EOL power output of between and 17.78 to 35.64 W is not adequate to supply NPSAT1 with the required power to support its experimental functions.

## VI. GALLIUM ARSENIDE CELLS

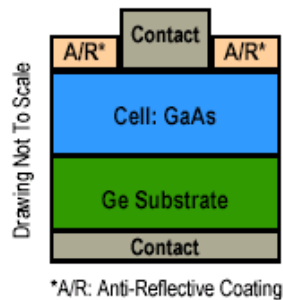
### A. NPSAT1 GALLIUM ARSENIDE PROSPECTIVE CELLS

To do a comparison between the cells that NPSAT1 could use to be most cost effective and produce the required power for all the subsystems and requirements, a study into the Gallium Arsenide solar cells is appropriate. The GaAs/Ge Single Junction Solar Cell by Spectrolab offers a great subject for analysis.



**Figure 37 GaAs/Ge Single Junction Cell [From Ref. 3].**

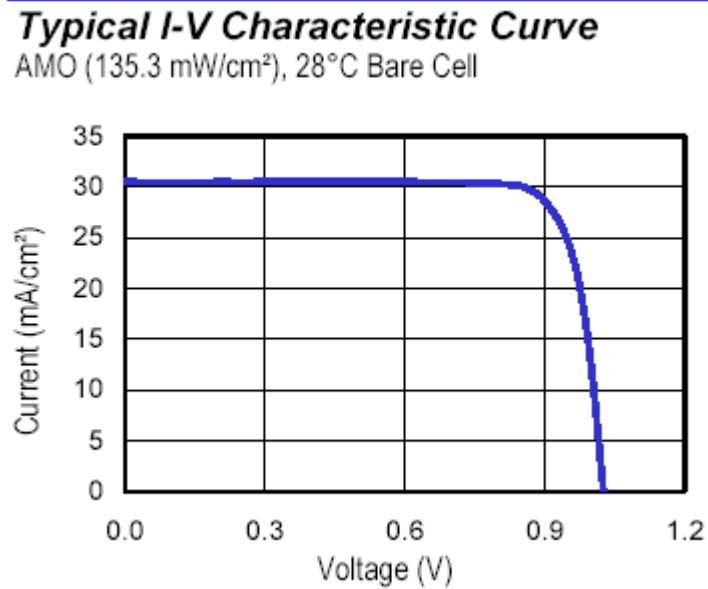
The GaAs/GE Single Junction Cell is made up of Gallium Arsenide with a Germanium substrate. This cell offers high efficiency, and high reliability due to its transparent insertion into existing systems, rugged reinforced thin cell (RTC) design, integral bypass diode, and no degradation with multiple assembly methods. This cell is currently available in high volume production. Figure 38 illustrates the cell make up of the GaAs/Ge single Junction cell.



**Figure 38 GaAs/Ge Cell [From Ref. 3].**

The typical electrical parameters for the GaAs/Ge single junction cell at maximum power are as follows: current 28.6 milliAmps/cm<sup>2</sup>, power 25.7 mW/cm<sup>2</sup>,

voltage 0.900 Volts. The efficiency for this cell is published at 19.0%. Figure 39 displays the typical I-V curve for this cell at AM0.



**Figure 39 GaAs/Ge I-V Curve [From Ref. 3].**

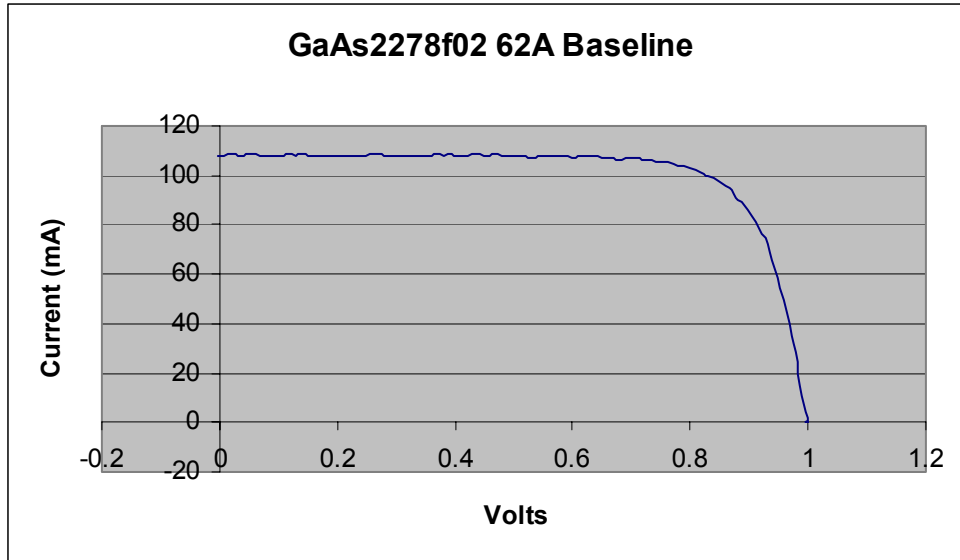
## **B. TEST CELLS AND PROCEDURES**

### **1. Background**

The Gallium Arsenide cells tested are not the exact cells of our study, but have representative results on the solar simulator and in the LINAC that apply to our study. Again, LT Michael Woods was the testing agent who completed testing in August of 2002 on the Gallium Arsenide samples.

### **2. Solar Simulator Testing**

The same solar simulator that tested the Silicon cells at the Naval Postgraduate School was used to test the Gallium Arsenide cells. These cells proved to have a 17 percent baseline efficiency as demonstrated by the I-V curve in Figure 40. Multiple test runs were made on the solar simulator to ensure accurate results.



**Figure 40 GaAs Solar Simulator Baseline I-V Curve [From Ref. 15].**

### 3. LINAC Testing

In order to obtain the radiation data on the Gallium Arsenide cells, the same example cells were irradiated by the LINAC at NPS by the same individual using the same procedures as with the Silicon Cells. Each type of cell required a full day of testing to ensure accurate results. As seen in Figure 41, the efficiency of the irradiated cell dropped from 17 percent to 7.65 percent efficient after being irradiated to  $1 \times 10^{16}$  electrons/cm<sup>2</sup>. This is an appreciable degradation which is also apparent in the maximum power curve which demonstrates a decline in power from 83.316 mW to 37.51 mW in Figure 42. The maximum current curve, Figure 43, shows a reduction of maximum current flow in the cell during irradiation from 100.05 mA/cm<sup>2</sup> to 61.405 mA/cm<sup>2</sup>. Figure 44 demonstrates the composite curves for the radiation testing. It is clear the effect of each level of electron fluence has upon the Gallium Arsenide cell in this figure.

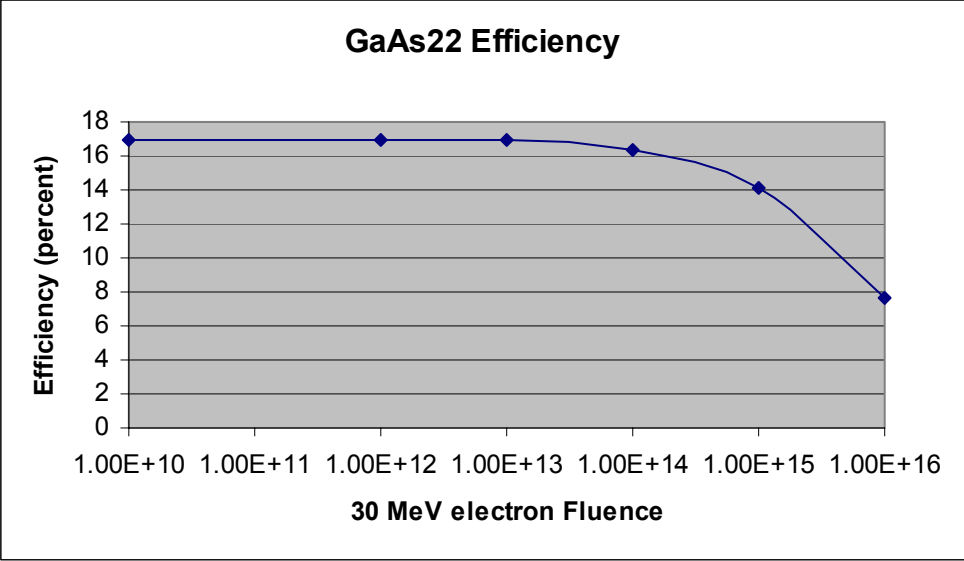


Figure 41 GaAs LINAC Testing Efficiency Curve [From Ref. 15].

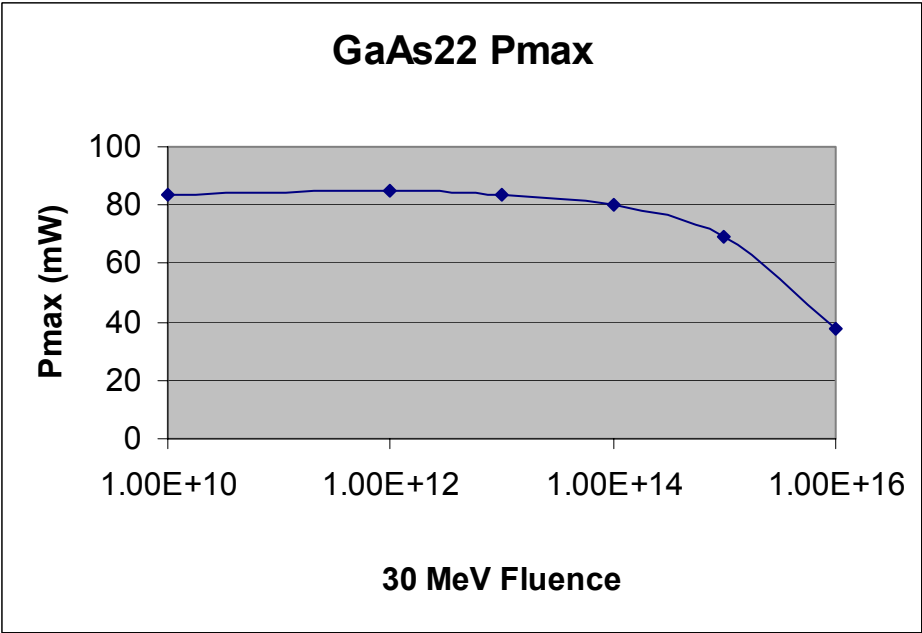


Figure 42 GaAs LINAC Testing Pmax Curve [From Ref. 15].

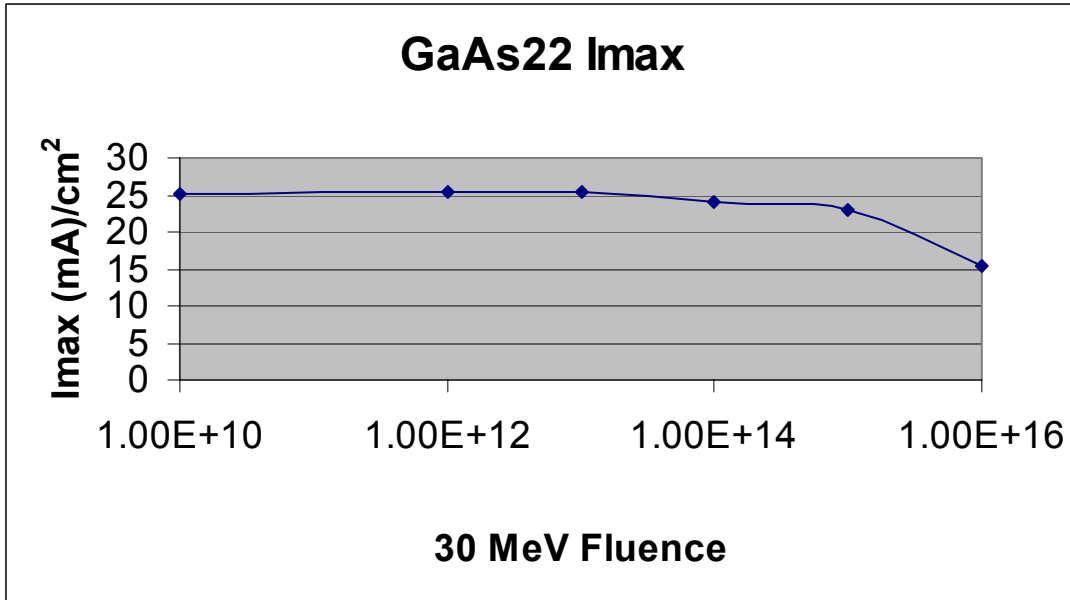


Figure 43 GaAs LINAC Testing Imax Curve [From Ref. 15].

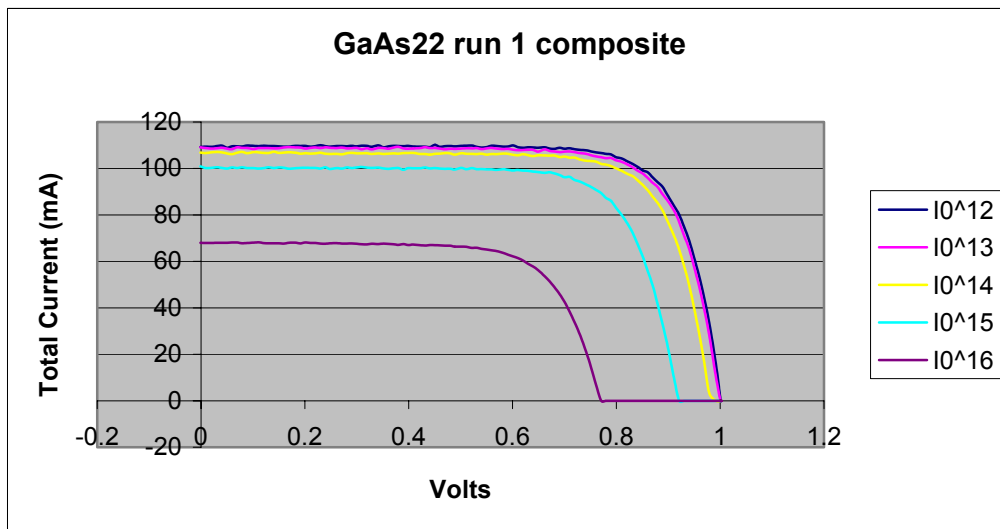


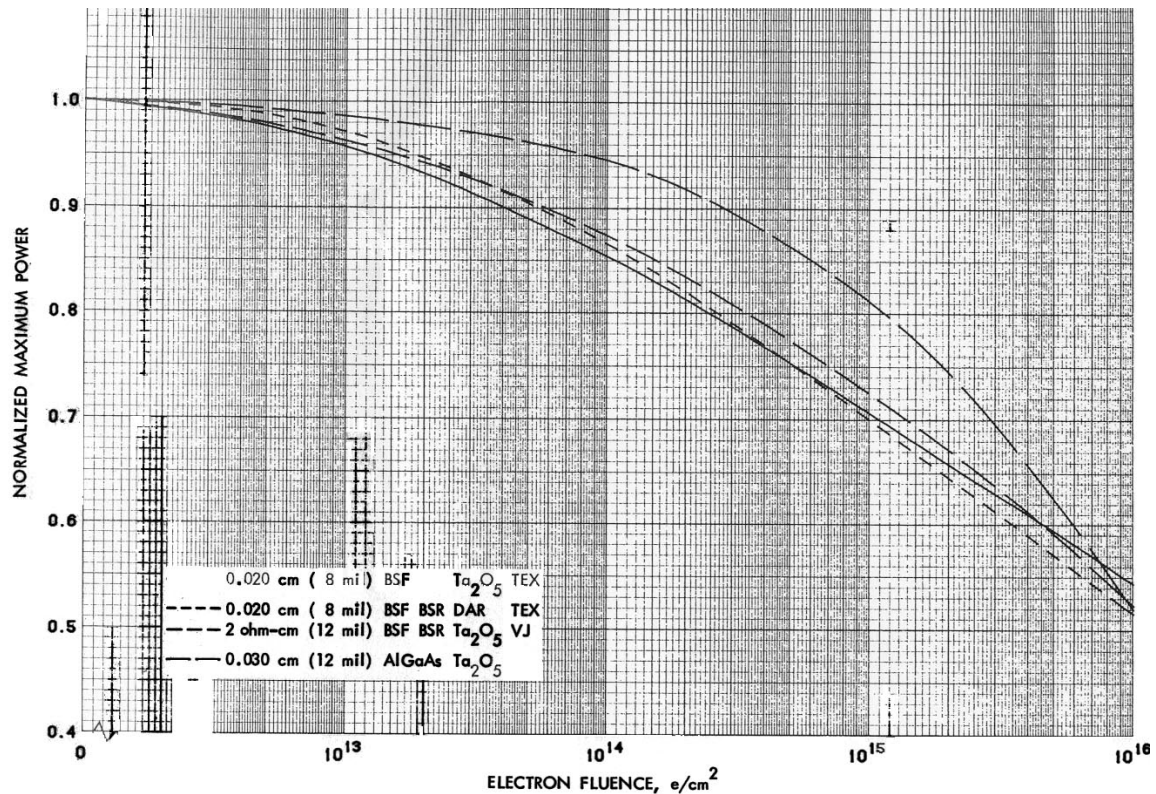
Figure 44 GaAs Cell LINAC Radiation Test Composite [After Ref. 15].

### C. FINDINGS

Based on the cell layout and electrical characteristics of the cell, the maximum output power for NPSAT1 if using the GaAs/Ge cell in accordance with the panel design is determined as follows:

$$P_{\max(\text{BOL})} = 25.7 \text{ mW/sqcm} * 2123.32 \text{ sqcm} = 54.569 \text{ W}$$

As stated previously the Beginning Of Life (BOL) maximum power figure is possible when the satellite is normal to the sun; however, the satellite's angle relative to the sun will vary over its orbit as previously discussed. As the long axis of the satellite changes angle relative to the sun's rays, the maximum power output drops as a function of the cosine of the angle.



**Figure 45 Normalized Pmax vs 1 MeV Electron Fluence for 10 Ohm-cm n/p Textured, 2 Ohm-cm Verticle Junction, and p/n AlGaAs Cells [From Ref. 12].**

NPSAT1 will orbit the earth at an altitude of 560 kilometers and an inclination of 35.4 degrees. Based upon the orbit information and the two-year mission life of the satellite, the total accumulated radiation dose needs to be determined. Using the tables within the *Solar Cell Radiation Handbook* Figure 45, and with some interpolation, the following MeV equivalent fluences were determined assuming a 12 mil shielding on the solar cells.

$$\text{Electron Fluence} = 3.32e+11$$

$$\text{Proton Fluence} = 8.76e+12$$

$$\text{Total Fluence} = 8.793e+12$$

From the electrical characteristic data of the solar cells and data provided by Figure 46, a fluence of  $1e+13$  will cause a 3 percent reduction in the maximum power output of the solar cell. Because the total fluence expected for NPSAT1 is approximately 88 percent of this amount, the ITJ solar cells will suffer a power reduction of approximately 2.64 percent. The maximum output power available at the End Of Life (EOL) for NPSAT1 is calculated by reducing the beginning of life power by 2.64 percent.

$$P_{\max(\text{EOL})} = P_{\max(\text{BOL})} * .9736 = 53.128\text{W}$$

<b>Radiation Degredation</b> (Fluence 1MeV Electrons/cm <sup>2</sup> )			
Parameters	$1 \times 10^{13}$	$1 \times 10^{14}$	$1 \times 10^{15}$
Imp/Imp <sub>0</sub>	0.99	0.95	0.83
Vmp/Vmp <sub>0</sub>	0.98	0.95	0.90
Pmp/Pmp <sub>0</sub>	0.97	0.90	0.75

**Figure 46 Ga/As Ge Radiation Degredation [From Ref. 3].**

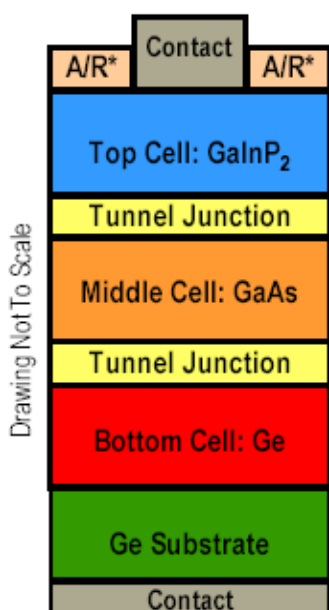
The EOL power output of 53.128 W is significantly more than the estimated power requirement. The Ga/As Ge cells though would come at a price to the NPSAT1 project which has not been provided. Although the cells themselves meet the required power output, the additional cost negates these cells from use on NPSAT1. The LINAC testing on the Ga/As cell supports this calculation, as the 30 MeV Electron Fluence on the cell diminished the efficiency by approximately 6 percent at  $1 \times 10^{14}$  and zero percent around the  $1 \times 10^{13}$  area according to Figure 41.

THIS PAGE LEFT INTENTIONALLY BLANK

## VII. TRIPLE JUNCTION SOLAR CELLS

### A. TRIPLE JUNCTION PROSPECTIVE CELLS

The solar cells selected for use in NPSAT1 are the Spectrolab Improved Triple Junction (ITJ) solar cells. The primary components of the ITJ cells are Gallium Indium Phosphide ( $\text{GaInP}_2$ ), Gallium Arsenide (GaAs), and Germanium (Ge). The basic construction of the ITJ cell is shown in Figure 47. These cells are designed for an efficiency of 26.8 percent. Figure 48 shows the typical electrical parameters for the cells and Figure 49 on the following page shows the ITJ cell IV characteristic curve provided by the manufacturer. Although the data has been calculated for a 26.8 percent triple-junction solar cell, the cells which NPSAT1 may be fitted with could possibly be as low as 22 percent efficiency as the contract for the cells is still not solidified.



\*A/R: Anti-Reflective Coating

**Figure 47 Triple Junction Cell [From Ref. 4].**

These cells by Spectrolab claim the following parameters at maximum power: current  $16.00 \text{ mA/cm}^2$ , and voltage 2.270 volts as seen in Figure 48. Maximum power is not included in this figure. The typical I-V curve for this triple junction cell is visible in Figure 49.

### Typical Electrical Parameters

(AM0 (135.3 mW/cm<sup>2</sup>) 28°C, Bare Cell)

$$J_{sc} = 16.90 \text{ mA/cm}^2$$

$$J_{mp} = 16.00 \text{ mA/cm}^2$$

$$J_{load\ min\ avg} = 16.10 \text{ mA/cm}^2$$

$$V_{oc} = 2.565 \text{ V}$$

$$V_{mp} = 2.270 \text{ V}$$

$$V_{load} = 2.230 \text{ V}$$

$$Cff = 0.84$$

$$Eff_{load} = 26.5\%$$

$$Eff_{mp} = 26.8\%$$

### Radiation Degradation

(Fluence 1 MeV Electrons/cm<sup>2</sup>)

Parameters	1x10 <sup>14</sup>	5x10 <sup>14</sup>	1x10 <sup>15</sup>
I <sub>mp</sub> /I <sub>mp0</sub>	1.00	0.98	0.96
V <sub>mp</sub> /V <sub>mp0</sub>	0.94	0.90	0.88
P <sub>mp</sub> /P <sub>mp0</sub>	0.94	0.88	0.84

Figure 48 Triple Junction Cell Parameters [From Ref. 4].

### Typical IV Characteristic

AM0 (135.3 mW/cm<sup>2</sup>) 28°C, Bare Cell

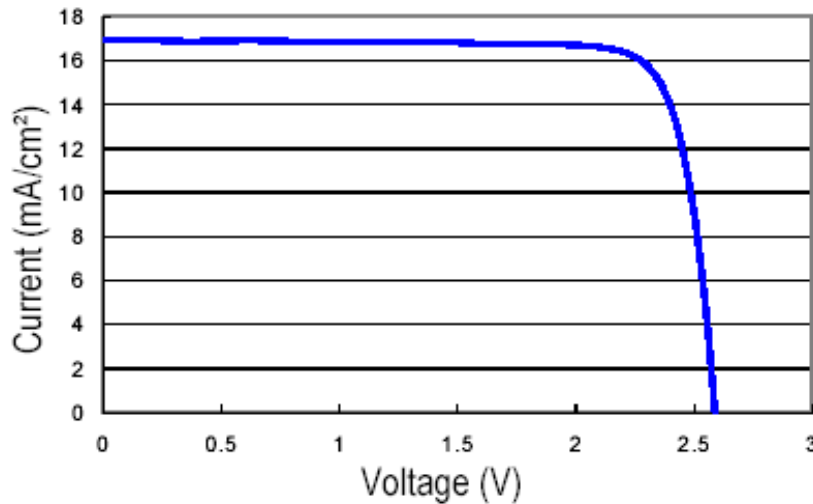


Figure 49 Typical I-V for Triple Junction Cell [From Ref. 4].

## B. TEST CELLS AND PROCEDURES

### 1. Background

The triple-junction test cells will be cells from Spectrolab at a given manufacturer efficiency of 24 percent. The testing was completed in August of 2002, in the same labs as the previous two types of solar cells. These are not the exact cells that were used to generate this study's EOL power output model, but are similar and are therefore used as example data.

### 2. Solar Simulator Testing

As the baseline I-V curve for these triple-junction cells displays, the cells showed a minimum of 24 percent efficiency rate when tested by the solar simulator. These results are consistent with the manufacturer's data on the product and therefore assist in determining accurate radiation levels with the next step in testing. The same testing procedures and equipment were used on these triple-junction cells as with the silicon and Ga/As cells in our study.

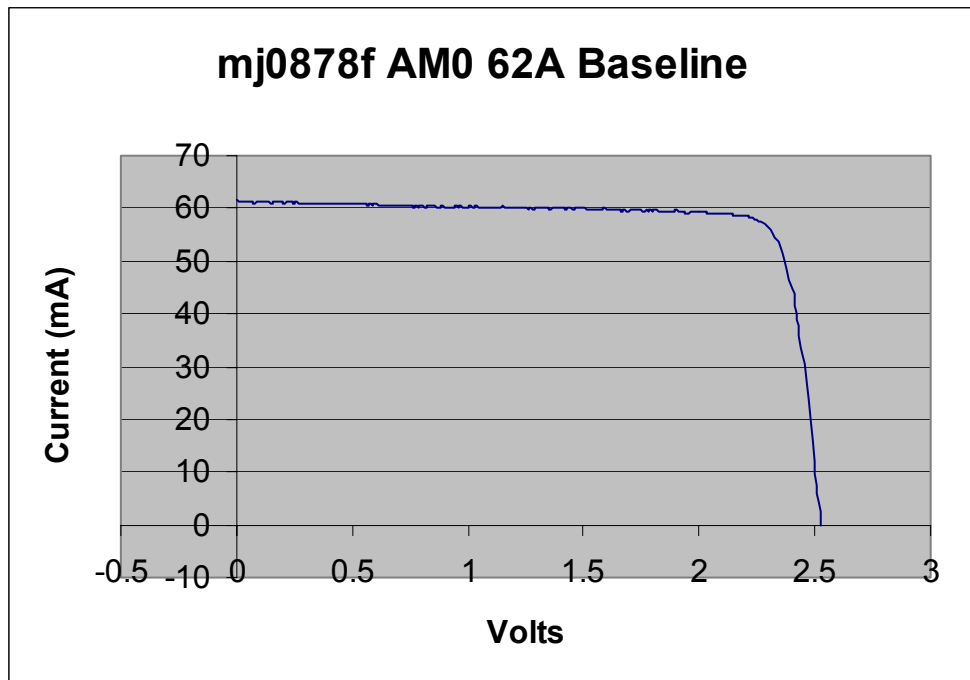
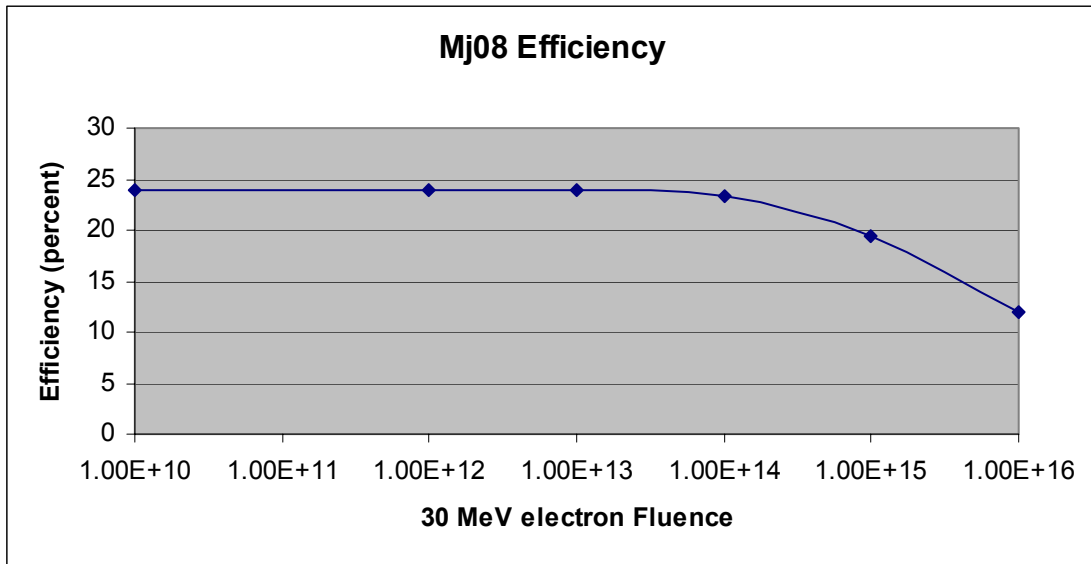


Figure 50 Multi-Junction Cell Baseline I-V Curve [From Ref. 15].

### 3. LINAC Testing

A full day of testing per cell was required for each multi-junction cell that was tested in the Naval Postgraduate School's Linear Accelerator. The same procedures were used as with the silicon and Ga/As cells and therefore the results are comparable. The radiation results were similar to the past two cells' degradation, efficiency dropped from 22 percent to 11.94 percent as seen with Figure 51.



**Figure 51 Triple-Junction Cell LINAC Testing Efficiency Curve [From Ref. 15].**

The maximum power output over the course of the irradiation dropped from 129.62 milliWatts to 64.746 as seen in Figure 52. The results of the maximum current curve, as viewable in Figure 53, demonstrates a degradation of 56.57 mA/cm<sup>2</sup> to 35.57 mA/cm<sup>2</sup> when testing was complete. Figure 54 illuminates the degradation curves at each level of accelerated electrons for the triple-junction solar cell.

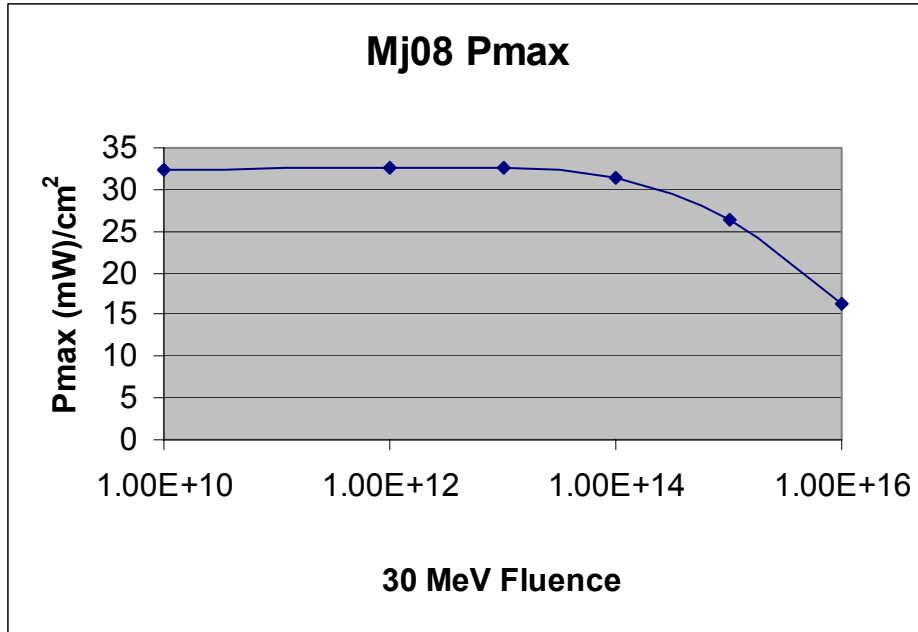


Figure 52 Triple-Junction Cell LINAC Testing Pmax Curve [From Ref. 15].

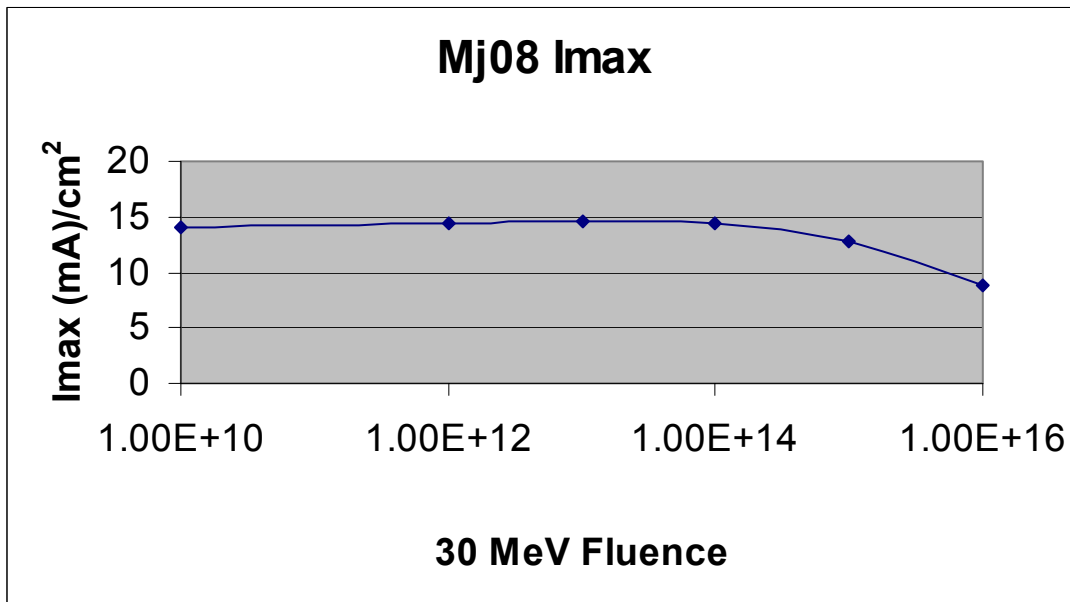


Figure 53 Triple-Junction Cell LINAC Testing Imax Curve [From Ref. 15].

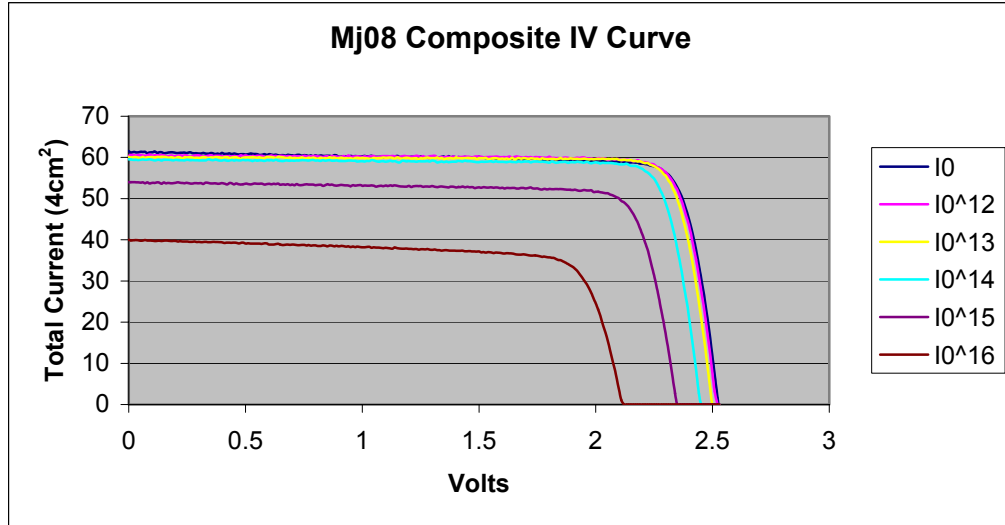


Figure 54 Triple-Junction Cell LINAC Radiation Testing Composite Curve [After Ref. 15].

### C. FINDINGS

Based on the cell layout and electrical characteristics of the triple junction cell, the maximum output power for NPSAT1 is determined as follows:

$$\text{Total Effective Area} = 2123.32 \text{ sqcm}$$

$$\text{Voltage (max power)} = 2.27 \text{ V}$$

$$\text{Current (max power)} = 16.0 \text{ mA/sqcm}$$

$$\text{Maximum Power/Cell} = 36.32 \text{ mW/sqcm}$$

$$P_{\text{max(BOL)}} = 36.32 \text{ mW/sqcm} * 2123.32 \text{ sqcm} = 77.19 \text{ W}$$

The Beginning Of Life (BOL) maximum power figure is possible when the satellite is normal to the sun; however, the satellite's angle relative to the sun will vary over its orbit as previously discussed. When the satellite is not in an eclipse, the solar array provides power in the range of 38.6 – 77.19 W.

From the electrical characteristic data of the solar cells, a fluence of  $8.793 \times 10^{12}$  will cause a zero percent reduction in the maximum power output of the solar cell.

The EOL power output of 77.19 W is significantly more than the estimated power requirement. This excess may be used to enhance the current planned experiments or to add more experiments to the mission. The LINAC testing corroborated the *Solar Radiation Handbook's* assessment of the triple junction cells. With 30 MeV Electron Fluence, the multi-junction cell does not begin to degrade until it is exposed to approximately  $5 \times 10^{13}$  electron fluence as seen in Figure 51.

THIS PAGE LEFT INTENTIONALLY BLANK

## **VIII. FOLLOW-ON WORK AND CONCLUSION**

### **A. FOLLOW-ON WORK**

Proceeding the completion of this thesis, a variety of follow-on work is possible in the solar power arena for NPSAT1. Currently a thesis is being prepared by another student to test the triple-junction solar panels on orbit. Testing of the individual cells and panels can be conducted in order to determine the true efficiency of the cells being used, in comparison to the manufacturer's data.

### **B. CONCLUSIONS**

Of the three cells tested, the triple junction solar cell is the best cell for NPSAT1 use. The silicon does not meet the required end of life power necessary to sustain NPSAT1's experimental functions. The GaAs/Ge cell exceeds the power requirement, yet would come at a price to the NPSAT1 budget. With an exceedingly large maximum power, and no dollar price tag, the triple junction cell by Spectrolab is the clear winner in this comparison. Radiation testing and solar simulator testing assisted in backing this conclusion. In the situation where the triple-junction cells were not available for NPSAT1 use, the GaAs/Ge cells would be the necessary winner over the silicon cells for use on the satellite. It should be noted, however, that test data used in this study was not statistical data since very few cells were irradiated. The data presented however, is typical for the cell test type.

With estimated power exceeding current requirements with the triple-junction cells, use of these cells allows both a greater power margin and increased operation of experiments. This offers more science to be performed by NPSAT1 in its short two-year mission life.

THIS PAGE LEFT INTENTIONALLY BLANK

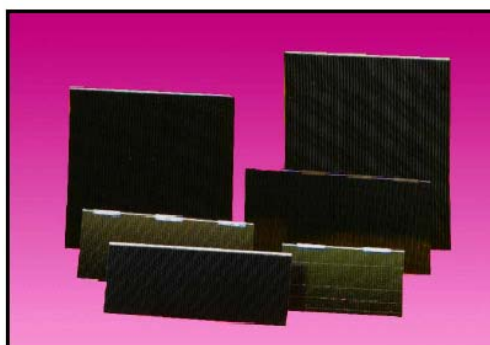
## APPENDIX A.



### Silicon K6700B Solar Cells

#### Features

- High Conversion Efficiency
  - Beginning of Life
  - End of life
- High state-of-the-art reliability
- Optimized operating temperature
- Hardened applications
  - Space environmental effects: military & commercial
  - Terrestrial power
  - Consumer products
- Low Cost
  - Standard Products
  - Custom Products



#### Product Description

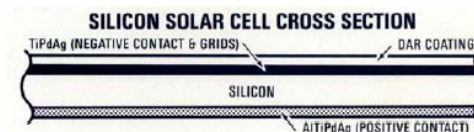
Standard/Special Product	Standard
Resistivity (p-type)	10 Ohm-cm
Crystal Orientation	1 - 0 - 0
Method of Growth	Czochralski
Shallow Junction	0.15 Micron
Metallization (Front)	TiPdAg
Metallization (Back)	AlTiPdAg
Anti-Reflective Coating	Multi-Layer
Back Surface Reflector	Aluminum
Back Surface Field	Boron
Sculptured Front Surface	No
Thickness	62 Microns
Sizes	Up to 8x8 cm
Weldable	Yes
Solderable	Sn62 Solder (QQ-S-571)

Note: other variations are available upon request

The information contained on this sheet is for reference only.  
Specifications subject to change without notice. 01/17/2000

#### Typical Qualification Test Results Nominal Degradation

Test	Description	Results
Humidity	+45°C, 90% RH Min., 30 Days	<1.5%
Thermal Cycle	+80°C to -180°C, 3000 Cycles	<2.5%
Thermal Shock	+140°C to -185°C, 5 Cycles	<1.5%
Thermal Soak	+140°C for 168 Hrs., $5 \times 10^{-5}$ torr	<1.5%
Radiation	Characterized thru $1 \times 10^{16}$ 1 MeV e/cm <sup>2</sup>	—
Pull Test	90° Pull, Standard Tab	>250 gm



**ISO9001:2000**  
REGISTERED

Spectrolab Inc. 12500 Gladstone Avenue, Sylmar, California 91342 USA • Phone: 818.365.4611 • Fax: 818.361.5102

### Typical Electrical Parameters {AM0 Sunlight (135.3 mW/cm<sup>2</sup>), 28°C}

$J_{sc}$  = 39.0 MilliAmperes/cm<sup>2</sup>

$J_{mp}$  = 37.0 MilliAmperes/cm<sup>2</sup>

$V_{mp}$  = 0.500 Volts

$P_{mp}$  = 18.5 MilliWatts/cm<sup>2</sup>

$V_{oc}$  = 0.605 Volts

Cff = 0.78

Efficiency 13.7% Minimum Average

### Radiation Degradation (Fluence e/cm<sup>2</sup> 1 MeV Electrons)

Parameter	1x10 <sup>14</sup>	5x10 <sup>14</sup>	1x10 <sup>15</sup>	2.5x10 <sup>15</sup>
Isc/Isc <sub>0</sub>	0.98	0.94	0.91	0.86
Imp/Imp <sub>0</sub>	0.98	0.93	0.90	0.85
Vmp/Vmp <sub>0</sub>	0.94	0.88	0.85	0.82
Voc/Voc <sub>0</sub>	0.96	0.90	0.87	0.82
Pmp/Pmp <sub>0</sub>	0.92	0.82	0.77	0.70

### Thermal Properties

Solar Absorptance = 0.75 (CMX)

Solar Absorptance = 0.73 (Fused Silica)

Emissance (Normal) = 0.85 (CMX)

Emissance (Normal) = 0.81 (Fused Silica)

### Weight

24 Milligrams/cm<sup>2</sup> (Bare)

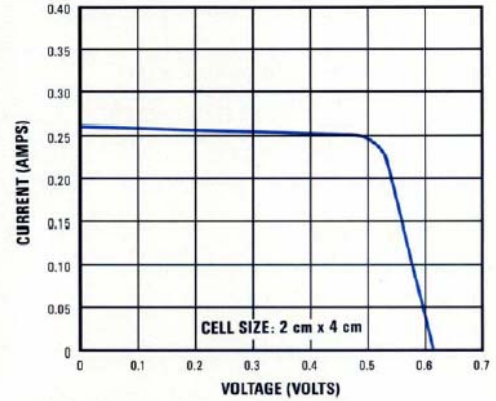
### Temperature Coefficients

Isc = +22.0 MicroAmperes/cm<sup>2</sup>

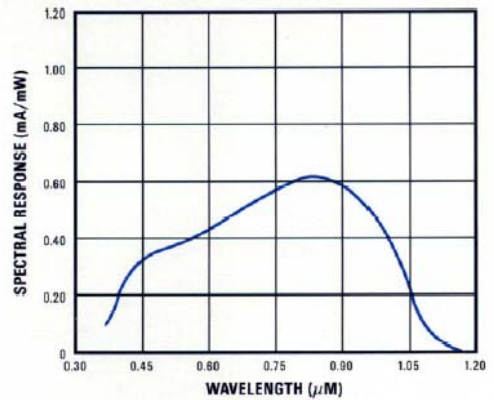
Vmp = -2.15 MilliVolts/°C

Voc = -1.96 MilliVolts/°C

### Typical I-V Characteristic Curve AM0 Sunlight (135.3 mW/cm<sup>2</sup>), 28°C



### Spectral Response



**ISO9001:2000**  
REGISTERED  
SPECTROLAB

A BOEING COMPANY

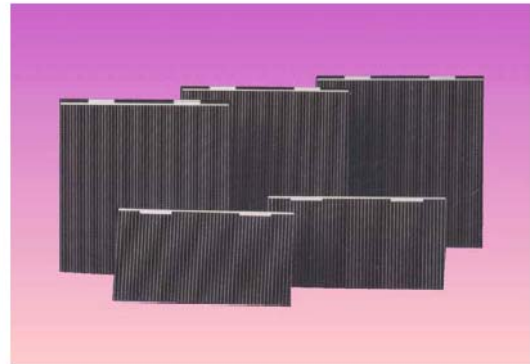
## APPENDIX B.



### GaAs/Ge Single Junction Solar Cells

#### Features

- High efficiency
  - Beginning of life
  - End of life
- High reliability
  - Transparent insertion into existing systems
  - Rugged reinforced thin cell (RTC) design
  - Integral bypass diode
  - No degradation with multiple assembly methods
- Availability
  - In high volume production

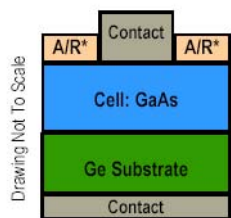


#### Product Description

Substrate	Germanium
Method of GaAs Growth	Metal Organic Vapor Phase Epitaxy
Polarity	p/n
Thickness	175 $\mu\text{m}$ 140 $\mu\text{m}$ (Mass Equivalent) RTC
Sizes	Up To 7 cm x 7 cm
Weldable/Solderable	Yes
Note: Other Variations Are Available Upon Request.	

#### Typical Qualification Test Results (Nominal Degradation)

Test	Description	Results
Humidity	+45°C, 90% RH Minimum 30 days	<1%*
Thermal Cycle	1600 Cycles -180° To 95°C	<2%*
Radiation	Characterized Through $1 \times 10^{15}$ MeV	—
Pull Test	Parallel Gap Welded Tabs (Ag, Ag Plated Kovar)	2N (Typical)
*CIC Assembly		



\*A/R: Anti-Reflective Coating



A BOEING COMPANY

Spectrolab Inc. 12500 Gladstone Avenue, Sylmar, California 91342 USA • Phone: 818.365.4611 • Fax: 818.361.5102

### Typical Electrical Parameters

(AMO Sunlight (135.3 mW/cm<sup>2</sup>), 28°C, Bare Cell)

$J_{sc} = 30.5 \text{ mA/cm}^2$

$J_{mp} = 28.6 \text{ mA/cm}^2$

$P_{mp} = 25.7 \text{ mW/cm}^2$

$V_{oc} = 1.025 \text{ V}$

$V_{mp} = 0.900 \text{ V}$

$Cf = 0.82$

Efficiency = 19.0%

### Radiation Degradation

(Fluence 1MeV Electrons/cm<sup>2</sup>)

Parameters	1x10 <sup>13</sup>	1x10 <sup>14</sup>	1x10 <sup>15</sup>
$I_{mp}/I_{mp_0}$	0.99	0.95	0.83
$V_{mp}/V_{mp_0}$	0.98	0.95	0.90
$P_{mp}/P_{mp_0}$	0.97	0.90	0.75

### Thermal Properties

Solar Absorptance = 0.89 (Ceria Doped Microsheet)

Solar Absorptance = 0.88 (Fused Silica)

Emittance (Normal) = 0.85 (Ceria Doped Microsheet)

Emittance (Normal) = 0.81 (Fused Silica)

### Weight

100 mg/cm<sup>2</sup> (Bare) @ 175 μm Thickness

80 mg/cm<sup>2</sup> (Bare) @ 140 μm Thickness

### Temperature Coefficients

(1x10<sup>15</sup> 1 MeV e/cm<sup>2</sup>)

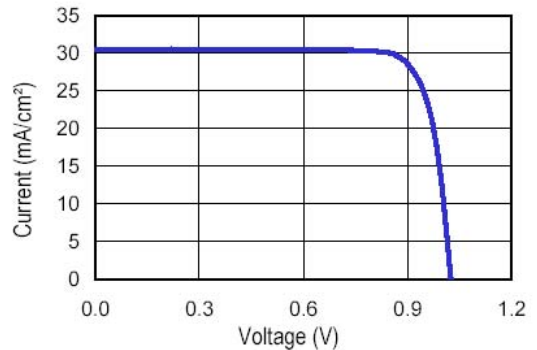
$I_{sc} = +20 \text{ } \mu\text{A/cm}^2/\text{°C}$

$V_{mp} = -1.90 \text{ mV/°C}$

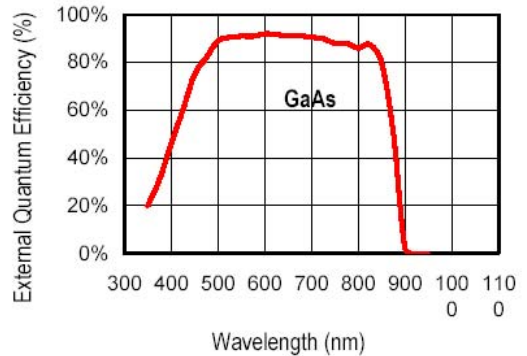
$V_{oc} = -1.80 \text{ mV/°C}$

### Typical I-V Characteristic Curve

AMO (135.3 mW/cm<sup>2</sup>), 28°C Bare Cell



### Quantum Efficiency

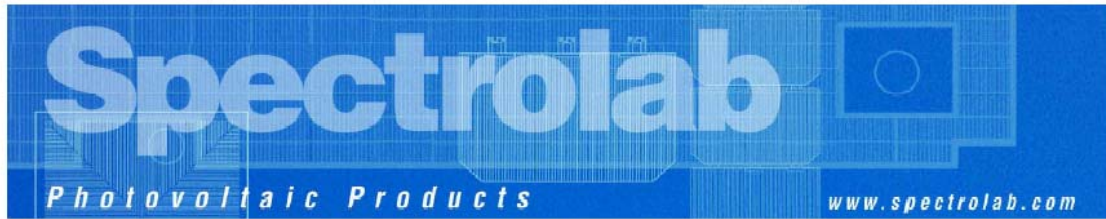


**ISO9001:2000**  
REGISTERED  
SPECTROLAB

A BOEING COMPANY

The information contained on this sheet is for reference only. Specifications subject to change without notice. 09/04/1997

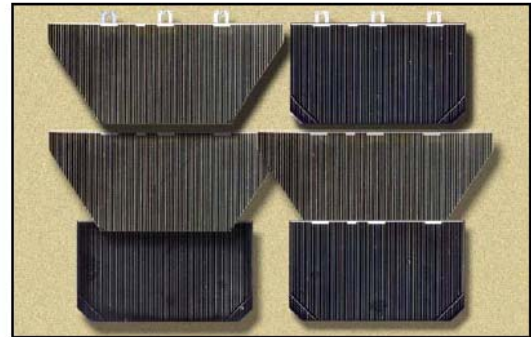
## APPENDIX C.



### 26.8% Improved Triple Junction (ITJ) Solar Cells

#### Features

- High efficiency n/p design (28°C, AM0)
  - BOL: 26.8% min. average efficiency @ maximum power (26.5% @ load voltage)
  - EOL: 22.5% min. average efficiency @ maximum power (22.3% @ load voltage), 1 MeV 1E15 e/cm<sup>2</sup>
- Integral bypass diode protection
- Transparent insertion into existing systems



#### Product Description

Substrate	Germanium
Solar Cell Structure	GaInP <sub>2</sub> /GaAs/Ge
Method of GaAs Growth	Metal Organic Vapor Phase Epitaxy
Device Design	Monolithic, two terminal triple junction. n/p GaInP <sub>2</sub> , GaAs, and Ge solar cells interconnected with two tunnel junctions
Sizes	Up To 31 cm <sup>2</sup>
Assembly Method	Multiple techniques including soldering, welding, thermocompression, or ultrasonic wire bonding
Integral Diode	Si diode integrated into recess on back side

Note: Other Variations Are Available Upon Request

#### Heritage

- More than 800 kW of multi-junction cells produced
- More than 225 kW of multi-junction arrays *on orbit*
- 1 MW annual capacity - cells, panels & arrays
- On orbit performance for multi-junction solar cells validated to ± 1.5% of ground test results

**ISO9001:2000  
 REGISTERED**

**SPECTROLAB**

A BOEING COMPANY

Spectrolab Inc. 12500 Gladstone Avenue, Sylmar, California 91342 USA • Phone: 818.365.4611 • Fax: 818.361.5102

## Typical Electrical Parameters

(AM0 (135.3 mW/cm<sup>2</sup>) 28°C, Bare Cell)

$$J_{sc} = 16.90 \text{ mA/cm}^2$$

$$J_{mp} = 16.00 \text{ mA/cm}^2$$

$$J_{load \text{ min avg}} = 16.10 \text{ mA/cm}^2$$

$$V_{oc} = 2.565 \text{ V}$$

$$V_{mp} = 2.270 \text{ V}$$

$$V_{load} = 2.230 \text{ V}$$

$$Cff = 0.84$$

$$Eff_{load} = 26.5\%$$

$$Eff_{mp} = 26.8\%$$

## Radiation Degradation

(Fluence 1 MeV Electrons/cm<sup>2</sup>)

Parameters	1x10 <sup>14</sup>	5x10 <sup>14</sup>	1x10 <sup>15</sup>
Imp/Imp <sub>0</sub>	1.00	0.98	0.96
Vmp/Vmp <sub>0</sub>	0.94	0.90	0.88
Pmp/Pmp <sub>0</sub>	0.94	0.88	0.84

## Thermal Properties

Solar Absorptance= 0.92 (Ceria Doped Microsheet)

Emittance (Normal)= 0.85 (Ceria Doped Microsheet)

## Weight

84 mg/ cm<sup>2</sup> (Bare) @ 140 μm (5.5 mil) Thickness

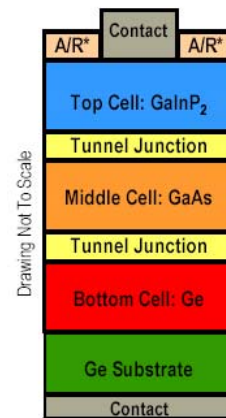
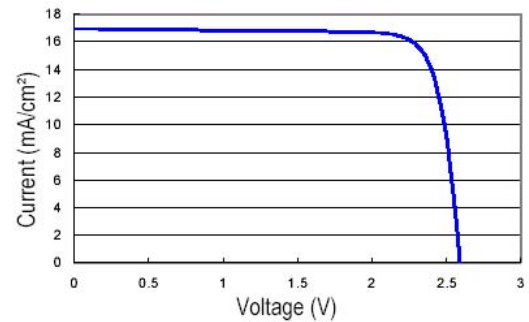
Thickness of 175 μm typical with weight equivalence of a 140 μm thick cell.

## Temperature Coefficients (10°C - 80°C)

Parameters	BOL	1x10 <sup>15</sup> (1 MeV e/cm <sup>2</sup> )
Jmp (μA/cm <sup>2</sup> /°C)	7.3	9.5
Jsc (μA/cm <sup>2</sup> /°C)	11.5	12.4
Vmp (mV/°C)	-6.2	-6.6
Voc (mV/°C)	-5.9	-6.5

## Typical IV Characteristic

AM0 (135.3 mW/cm<sup>2</sup>) 28°C, Bare Cell



\*A/R: Anti-Reflective Coating

ISO9001:2000  
REGISTERED

SPECTROLAB

A BOEING COMPANY

The information contained on this sheet is for reference only. Specifications subject to change without notice. 5/8/2002

## LIST OF REFERENCES

1. CDR Data Package. [<http://www.sp.nps.navy.mil/npsat1/Secured>]. April 2002.
2. Fifer, T. L., Radiation Effects on Multi-junction Solar Cells, Master's Thesis, Naval Postgraduate School, Monterey, CA, December 2001.
3. GaAs/Ge Single Junction Solar Cells.  
[<http://www.Spectrolab.com/DataSheets/SJCell/sj.pdf>]. September 1997.
4. Improved Triple Junction Solar Cells.  
[<http://www.spectrolab.com/DataSheets/TNJCell/tnj.pdf>]. May 2002.
5. NPS Research, Volume 11, Number 2, June 2001.
6. NPSAT1 Design Overview.  
[<http://www.sp.nps.navy.mil/npsat1/technical/NPSAT1.htm>]  
August 2001.
7. "PANSAT." [<http://www.sp.nps.navy.mil/pansat/>]. July 2001.
8. Reuer, C. R., Project Overview of the Naval Postgraduate School Spacecraft Architecture and Technology Demonstration Experiment, Master's Thesis, Naval Postgraduate School, Monterey, CA, September 2001.
9. Sakoda, Dan and Horning, James A., Overview of the NPS Spacecraft Architecture and Technology Demonstration Satellite, NPSAT1, Naval Postgraduate School, Monterey, CA. May 2002.
10. Sakoda, Dan, Project Simulation, [NPSAT1Loads\_Apr02.m]. Naval Postgraduate School, Monterey, CA. April 2002.
11. Silicon K6700B Solar Cells.  
[<http://www.spectrolab.com/DataSheets/K6700B/k6700b.pdf>]. January 2000.
12. *Solar Cell Radiation Handbook*, 3<sup>rd</sup> Edition, NASA/JPL Publication no. 82-69. July 1996.
13. Ultralife Batteries. [<http://www.ultralifebatteries.com/product-display.asp?id=39>]  
August 2001.
14. Wertz, J.R. and Larson, W. J., *Space Mission Analysis and Design*, 3d ed., Microcosm Press, 1999.

15. Woods, M. D., A Comparative Analysis of Radiation Induced Effects on Silicon, GaAs and GaInP<sub>2</sub>/GaAs/Ge Multi-Junction Solar Cells Using a 30 MeV Electron Linear Accelerator, Master's Thesis, Naval Postgraduate School, Monterey, CA, September 2002.

## INITIAL DISTRIBUTION LIST

1. Defense Technical Information Center  
Ft. Belvoir, Virginia
2. Dudley Knox Library  
Naval Postgraduate School  
Monterey, California
3. Professor Sherif Michael  
Naval Postgraduate School  
Monterey, California
4. Dan Sakoda  
Naval Postgraduate School  
Monterey, California