

USAARL Report No. 2002-23
Volume I

A Comparison of Visual Fields with Fixed and Moving Fixation Points (Reprint)

by William E. McLean

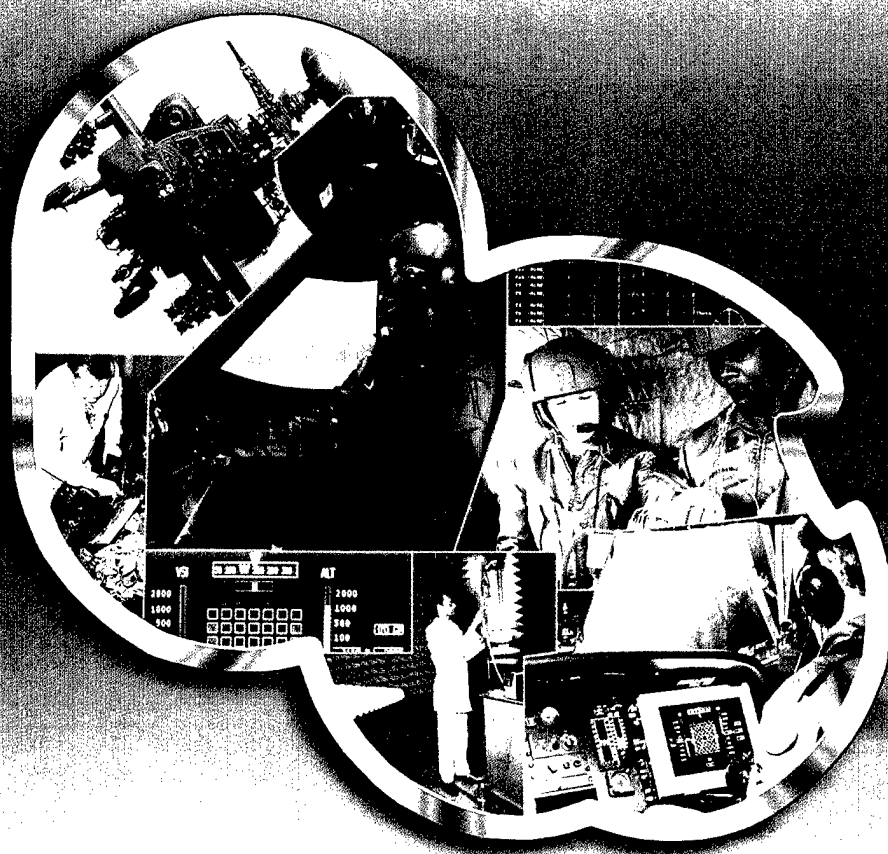

Aircrew Health and Performance Division

September 2002

Approved for public release, distribution unlimited.

20021029 048

U
S
A
A
R
L

U.S. Army
Aeromedical Research
Laboratory

Notice

Qualified requesters

Qualified requesters may obtain copies from the Defense Technical Information Center (DTIC), 8725 John J. Kingman Road, Suite 0944, Fort Belvoir, Virginia 22060-6218. Orders will be expedited if placed through the librarian or other person designated to request documents from DTIC.

Change of address

Organizations receiving reports from the U.S. Army Aeromedical Research Laboratory on automatic mailing lists should confirm correct address when corresponding about laboratory reports.

Disposition

Destroy this document when it is no longer needed. Do not return it to the originator.

Disclaimer

The views, opinions, and/or findings contained in this report are those of the author(s) and should not be construed as an official Department of the Army position, policy, or decision, unless so designated by other official documentation. Citation of trade names in this report does not constitute an official Department of the Army endorsement or approval of the use of such commercial items.

Human use

Human subjects participated in these studies after giving their free and informed voluntary consent. Investigators adhered to AR 70-25 and USAMRMC Reg 70-25 on Use of Volunteers in Research.

REPORT DOCUMENTATION PAGE

1a. REPORT SECURITY CLASSIFICATION Unclassified			1b. RESTRICTIVE MARKINGS											
2a. SECURITY CLASSIFICATION			3. DISTRIBUTION / AVAILABILITY OF REPORT Approved for public release, distribution unlimited											
2b. DECLASSIFICATION / DOWNGRADING														
4. PERFORMING ORGANIZATION REPORT NUMBER(S) USAARL Report No. 2002-23			5. MONITORING ORGANIZATION REPORT NUMBER(S)											
6a. NAME OF PERFORMING ORGANIZATION U.S. Army Aeromedical Research Laboratory		6b. OFFICE SYMBOL <i>(if)</i> MCMR-UAD	7a. NAME OF MONITORING ORGANIZATION U.S. Army Medical Research and Materiel Command											
6c. ADDRESS (City, State, and ZIP Code) P.O. Box 620577 Fort Rucker, AL 36362-0577			7b. ADDRESS (City, State, and ZIP Code) 504 Scott Street Fort Detrick, MD 21702-5012											
8a. NAME OF FUNDING / SPONSORING ORGANIZATION		8b. OFFICE SYMBOL <i>(if)</i>	9. PROCUREMENT INSTRUMENT IDENTIFICATION NUMBER											
8c. ADDRESS (City, State, and ZIP Code)			10. SOURCE OF FUNDING NUMBERS <table border="1" style="width: 100%; border-collapse: collapse; margin-top: 5px;"> <tr> <th style="width: 25%;">PROGRAM ELEMENT NO.</th> <th style="width: 25%;">PROJECT NO.</th> <th style="width: 25%;">TASK NO.</th> <th style="width: 25%;">WORK UNIT ACCESSION NO.</th> </tr> <tr> <td> </td> <td> </td> <td> </td> <td> </td> </tr> </table>				PROGRAM ELEMENT NO.	PROJECT NO.	TASK NO.	WORK UNIT ACCESSION NO.				
PROGRAM ELEMENT NO.	PROJECT NO.	TASK NO.	WORK UNIT ACCESSION NO.											
11. TITLE (Include Security Classification) (U) A Comparison of Visual Fields with Fixed and Moving Fixation Points, Volume I														
12. PERSONAL AUTHOR(S) William E. McLean														
13a. TYPE OF REPORT Final		13b. TIME COVERED FROM TO		14. DATE OF REPORT (Year, Month, 2002 September	15. PAGE COUNT 97									
16. SUPPLEMENTAL NOTATION														
17. COSATI CODES <table border="1" style="width: 100%; border-collapse: collapse; margin-top: 5px;"> <thead> <tr> <th style="width: 33%;">FIELD</th> <th style="width: 33%;">GROUP</th> <th style="width: 33%;">SUB-GROUP</th> </tr> </thead> <tbody> <tr> <td>23</td> <td>02</td> <td> </td> </tr> <tr> <td>20</td> <td>06</td> <td> </td> </tr> </tbody> </table>			FIELD	GROUP	SUB-GROUP	23	02		20	06		18. SUBJECT TERMS (Continue on reverse if necessary and identify by block number) Visual field measurements, target detection, contrast saccadic suppression, target velocity, visual lobe, binocular visual fields		
FIELD	GROUP	SUB-GROUP												
23	02													
20	06													
19. ABSTRACT (Continue on reverse if necessary and identify by block number) Four procedures were used to measure the extent of the detection fields of four primary meridians of the binocular visual fields of four subjects. Procedures I (Moving Target) used a horizontally moving target and a stationary fixation point. Procedure II (Fixed Target) used a stationary target and a horizontally moving fixation point. Procedure III (Saccadic Move) used a saccadic eye movement between two stationary horizontal fixation points and a stationary target. Procedure IV (Flashed Target) used a stationary fixation point and a .6 second flashed target. The results from the dynamic procedures (I and II) and the two static procedures (III and IV) were very similar for each subject. In the dynamic procedures, the relationship between a change in contrast and an equivalent change in velocity tends to support Bloch's Law ($IxT=C$) between 2 deg/s and 20 deg/s for a given retinal location. The relationship between the reciprocal of relative single glimpse probability of four subjects measured in this study and the mean detection times for comparable stimuli taken from Krendel and Wodinsky's Study (1960) appear to be linear and highly correlated (.92 to .99). Volume I of this report details the technical report and volume II contains the appendices.														
20. DISTRIBUTION / AVAILABILITY OF <input checked="" type="checkbox"/> UNCLASSIFIED/UNLIMITED <input type="checkbox"/> SAME AS RPT. <input type="checkbox"/> DTIC USERS			21. ABSTRACT SECURITY CLASSIFICATION Unclassified											
22a. NAME OF RESPONSIBLE INDIVIDUAL Chief, Science Information Center			22b. TELEPHONE (Include Area (334) 255-6907		22c. OFFICE SYMBOL MCMR-UAX-SI									

A Comparison of Visual Fields with
Fixed and Moving Fixation Points

A Thesis

Presented to

The Graduate Faculty of the College of Optometry
University of Houston

In Partial Fulfillment
of the Requirements for the Degree
Master of Science in Physiological Optics

By

William E. McLean

October 1983

A Comparison of Visual Fields with
Fixed and Moving Fixation Points



William Earl McLean

Approved:



Donald G. Pitts, O.D., Ph.D.
Chairman



Ronald S. Harwerth, O.D., Ph.D.



Bruno G. Breitmeyer, Ph.D.

Acknowledgements

I wish to acknowledge Dr. Donald Pitts for guidance and assistance as chairman of my thesis committee. The advice and critique by Dr. Bruno G. Breitmeyer and Dr. Ronald S. Harwerth were most helpful in preparing this study. I would also like to acknowledge James McLean for electronic assistance and Ms. Jeannette Hinkle and Ms. Wanda Whitlock for typing this thesis.

A Comparison of Visual Fields with
Fixed and Moving Fixation Points

An Abstract of a Thesis

Presented to

The Graduate Faculty of the College of Optometry
University of Houston

In Partial Fulfillment
of the Requirements for the Degree
Master of Science in Physiological Optics

By

William E. McLean

October 1983

Abstract

Four procedures were used to measure the extent of the detection fields of four primary meridians of the binocular visual fields of four subjects. Procedure I (Moving Target) used a horizontally moving target and a stationary fixation point. Procedure II (Fixed Target) used a stationary target and a horizontally moving fixation point. Procedure III (Saccadic Move) used a saccadic eye movement between two stationary horizontal fixation points and a stationary target. Procedure IV (Flashed Target) used a stationary fixation point and a .6 second flashed target. The results from the dynamic procedures (I and II) and the two static procedures (III and IV) were very similar for each subject. In the dynamic procedures, the relationship between a change in contrast and an equivalent change in velocity tends to support Bloch's Law ($I \times T = C$) between 2 deg/s and 20 deg/s for a given retinal location. The relationship between the reciprocal of relative single glimpse probability of four subjects measured in this study and the mean detection times for comparable stimuli taken from Krendel and Wodinsky's Study (1960) appear to be linear and highly correlated (.92 to .99).

TABLE OF CONTENTS

CHAPTER		PAGE
I	Introduction	1
	A. History	1
	B. Relationship of Visual Fields to Visual Search Modeling	2
	C. Visual Field Size and Fixations in Target Detection Probability	3
	D. Theory of Visual Lobe Size and Relative Retinal Motion	7
	E. The Purpose of Study	13
II	Instrumentation and Procedures	14
	A. Approach	14
	B. Equipment and Arrangement	15
	C. Electronic Operation	15
	D. Optical and Mechanical Operation	18
	E. Calibration and Verification	21
	F. Variables Examined	26
	G. Subjects	31
	H. Description of Procedures	31
III	Results	36
	A. Meridian Plots for Each Subject and Procedure	36
	B. Vertical and Horizontal Relationships of the Visual Fields	37
	C. Relative Size of the Visual Fields	48
	D. Comparison Between Procedures	58

TABLE OF CONTENTS (Continued)

CHAPTER	PAGE
E. Relationship Between Change in Contrast and Velocity	69
F. Relationship Between $1/P_{sg}$ and Mean Detection Time	76
IV Discussion	88
Summary and Conclusions	92
References	93
Appendix	98
A. List of Equipment and Model Numbers	99
B. Means, Standard Deviations, Correction Factors, and Calibration Values for Each Subject, Procedures, Meridian, Velocity, and Contrast Value	101
C. Meridian Plots for Each Subject and Procedures	140
D. Four Primary Meridian Plots for Each Subject and Procedures	181
E. Relationship Between Contrast and Velocity for Subjects BM and DP	198
F. Relationship Between Mean Detection Time and $1/P_{sg}$ for Each Subject	207

LIST OF FIGURES

FIGURE		PAGE
1.	Relationship Between Visual Lobes and Detection Probability	4
2.	Constant Size Visual Lobe Theory	8
3.	Bloch's Law and Variable Size Visual Lobe Theory	10
4.	Electrical and Optical Schematic	16
5.	Physical Equipment Arrangement	19
6.	Optical Scanner Calibration (Horizontal)	24
7.	Optical Scanner Calibration (Vertical)	27
8.	Visual Field Meridians	32
9.	Plot of Four Meridians for Moving Target Procedure at 43% Contrast	38
10.	Plot of Four Meridians for Fixed Target Procedure at 43% Contrast	40
11.	Plot of Four Meridians for Saccadic Move Procedure	42
12.	Plot of Four Meridians for Flashed Target Procedure	44
13.	Plot of Calculated Area of Visual Fields for Procedure I for Each Subject	49
14.	Plot of Calculated Area of Visual Fields for Procedure II for Each Subject	51
15.	Plot of Calculated Area of Visual Fields for Procedure III for Each Subject	53
16.	Plot of Calculated Area of Visual Fields for Procedure IV	55
17.	Comparison of the Area of the Visual Fields Between Procedures I and II at 43% Contrast	59

LIST OF FIGURES (Continued)

FIGURE		PAGE
18.	Comparison of the Area of the Visual Fields Between Procedures III and IV	61
19.	Plot of the Relationships Between Contrast and Velocity for a Given Retinal Location	71
20.	Relationship Between Mean Detection Time and the Reciprocal of Single Glimpse Probability	77
21.	Relationship Between Mean Detection Time and the Reciprocal of Relative Single Glimpse Probability for Subject BM Measured with a Reflex Sighting Device	84

LIST OF TABLES

TABLE	TITLE	PAGE
1	Screen Luminance	23
2	Neutral Density Filter Transmissions, Target Luminance, and Contrast Determination	30
3	Averaged Meridian Size in Degrees and ± 1 Standard Deviation for Four Subjects and Four Procedures	46
4a	Comparison Between Procedures for Subject BM	63
4b	Comparison Between Procedures for Subject BM	64
5	Comparison Between Procedures for Subject DP	65
6a	Comparison Between Procedures for Subject RH	66
6b	Comparisons Between Procedures for Subject RH	67
7	Comparison Between Procedures for Subject DH	68
8	Relationship Between a Change in Contrast to a Change in Velocity	70
9	Relationship Between Relative $1/P_{sg}$ and Mean Detection Time for Each Procedure for Subject BM	86

CHAPTER I

INTRODUCTION

A. History

The functional size of the visual field for a given subject and physical experimental condition has a degree of variability (Tate, 1977). In addition to the training and fatigue effect, the method of measurement is important. Static and kinetic perimetry may produce different results at different retinal positions (Fankhauser and Schmidt, 1960). With static perimetry, temporal summation increases retinal response up to approximately .5 seconds for small targets and the light adapted eye (Aulhorn and Harms, 1972). Changing velocity of the target with kinetic perimetry changes the field size (Goldmann, 1945; Fankhauser, 1969; Van de Brink, 1954; Nurdygin, 1968) but the effect has not been well quantified. Burg (1968) found a gradual decrease in the size of the visual fields from ages 16 to 50 with more rapid decline after age 50. Farrimond (1967) also found a decrease in dynamic visual acuity (DVA) with age. Binocular visual fields are larger than monocular fields (Harrington, 1964) when overlapped and centered at the right and left fixation points due to increased temporal field sensitivity and compensated nasal obstruction.

- Published data of binocular visual fields are limited since commercially available perimeters are designed for monocular testing.

B. Relationship of Visual Fields to Visual Search Modeling

In a study by Krendel and Wodinsky (1960) the mean time to detect targets in an unstructural visual field was investigated. Using four subjects and 3072 search trials each, the variables examined were background lamination, size of targets, size of search area, and contrast between the targets and background. The authors' mathematical search model was a simple probability summation model (Pirenne, 1943) derived from a report by Lamar (1946). The probability of detecting a target was based on the probability of detecting a target on a single visual fixation or single glimpse (P_{sg}) and the number of fixations or glimpses in the specified search area. Single glimpse probability was considered a constant, and assuming successive fixations are independent, and random, the probability of detecting a target after the number of glimpses was expressed as follows: $P_{kg} = 1 - (1 - P_{sg})^k$; where k equals the number of glimpses; P_{sg} equals the probability of detection on a single glimpse; and P_{kg} equals the probability of detection after k glimpses or fixations.

The probability of detecting a target on a single glimpse (P_{sg}) depends on target eccentricity and the size of the area to be searched. If the loci of all maximal eccentricities at which the target can be detected are defined, the conspicuity of this target can also be defined as an area (measured in steradians or square degrees), somewhat circular in shape, and commonly referred to as the visual lobe for a particular target. P_{sg} , therefore, is defined as the ratio of the area of the visual lobe to the area to be searched for a randomly located target in an unstructured field.

Williams' (1966a) report shows that visual search in an unstructured background is not random, but is generally organized such that the subject's fixations avoid overlap until the entire area has been searched once. Williams' mathematical model deals with the probability of detection for a single scan of the area (P_{ss}) and the number of times the area is scanned (N) such that $P(N \text{ scans}) = 1 - (1 - P_{ss})^N$.

C. Visual Field Size and Fixations in Target Detection Probability

The visual lobe's shape may vary with conspicuity of a target from a circle to an irregular ellipse, but for simplicity of discussion the visual lobe will be considered a circle. To determine the minimum number of glimpses required to find a target with 100% probability for a given size area, the visual lobes from each glimpse must overlap (Fig. 1A) in an organized search pattern. If the visual lobes barely contact each other, (Fig. 1B), the probability of detection for one scan of the area is .785 or $\pi/4$. In figure 1B, the distance between the center of the visual lobes equals .707 X diameter of one visual lobe (d_{vl}), or the cosine of 45 degrees. The minimum number of glimpses required for 100% detection for a given rectangular area would range from one glimpse to (height of search area / .707 X $[d_{vl}]$) times (width of search area / .707 X $[d_{vl}]$) = N (glimpses). Since glimpses are only whole numbers, a fractional value for the height and width ratio to glimpse diameter would be raised to the next whole number.

To determine the time required to cover a given size search area with a perfect scanning pattern for a particular stimulus, the time between glimpses must be determined. In a study by Ford, et. al.

Figure 1 - Separation between visual lobes and detection probability.

Separation between visual lobes and detection probability

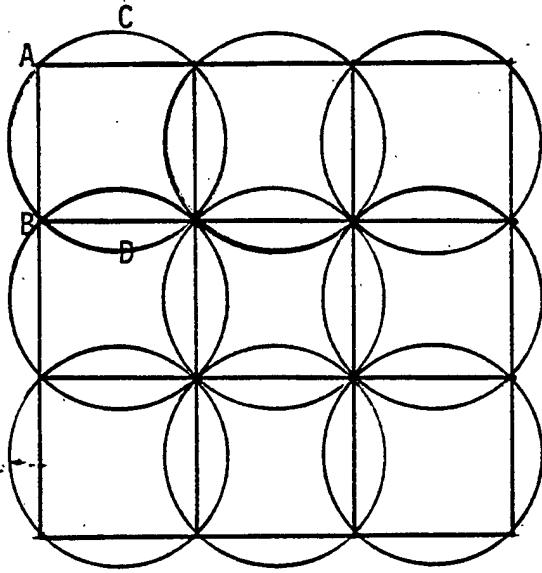

$$AB = .707 CD$$

Probability of detection = 1
for one scan of area

Figure 1A. Overlapping visual lobes.

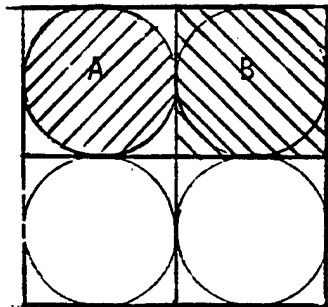

$$A = .785 B$$

Probability of detection = .785
for one scan of area

Figure 1B. Adjacent visual lobes.

Figure 1

(1959) on the analysis of eye movements during free search, using six subjects they found a range of fixation time for a five second search trial from about .05 to .60 seconds with a mean of approximately .30 seconds. The size of an eye movement in the 30 degree circular field ranged from 1 to 25 degrees with a mean of 8.6 degrees. Barnes (1976) recorded eye movements of 10 pilots searching for ground targets from a helicopter. The average fixation time on any one item was .9 seconds with an average upper range of approximately 5 seconds. There are several major differences between the laboratory and field study. In the Ford study, the subjects had only to detect a target in an unstructured background in 5 seconds. In the Barnes study, the pilots had to detect and identify a target in a complex background as quickly as possible with no set time limit.

The effect of practice or learning in a search procedure is evident in a study by Neisser (1963). In searching for a letter in a matrix of letters the average time per item was .6 seconds the first day and .1 seconds after twenty-two days of practice. Studies of eye movements indicate that search in an unstructured field is neither purely random nor perfectly organized, and the time between fixations varies considerably for a given subject. Consequently, studies that try to evaluate stimulus differences with time to detection are characterized by target location and subject differences (variables) that tend to mask the variable under investigation, and require a large number of trials to detect stimulus differences. The conspicuity of targets has been indirectly calculated with search studies. By measuring the conspicuity or the visual lobe of a target on a particular background with the eyes in motion in a controlled searching manner, search probability

calculations and studies could be simplified. By creating a theoretical standard with a optimal scanning pattern, individual performances could be evaluated and judged relative to this standard.

D. Theory of Visual Lobe Size and Relative Retinal Motion

The manner in which the average size of the visual lobe changes with target velocity relative to the fixation point is unknown. This study will attempt to measure these changes and to differentiate for a given velocity component whether (1) the visual system has a constant size visual lobe for a particular stimulus, but the decrease in the measured visual fields is due to the separation of the number of successive lobes by independent glimpses or visual frames per unit time (Fig. 2); (2) whether target or eye movement actually decreases the size of the visual lobe from less energy on a given receptive field per unit time and there are no independent glimpses, but continuous depressed inputs from visual stimuli (Fig. 3); or (3) some combination of both.

Bloch's Law, that intensity times time ($I \times T$) is a constant for short duration stimuli under approximately 30 ms (Brindley, 1959), would imply that doubling the stimulus velocity would require a doubling of the stimulus intensity at threshold for a particular receptive field. With decreasing stimulus velocities (i.e., crossing a receptive field in more than approximately 30 ms) inhibition component should increase, resulting in a decrease in the detection lobe (Fig. 3B).

In the first case, with glimpses the visual system would be comparable to a motion picture camera. If the visual event occurred

Figure 2 - Same size visual lobes, separated by eye movement velocity.

Same size visual lobes, separated by eye movement velocity

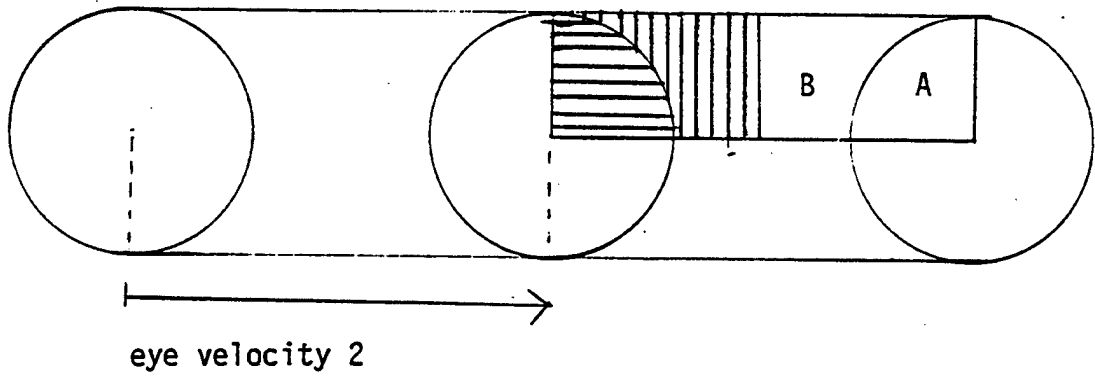
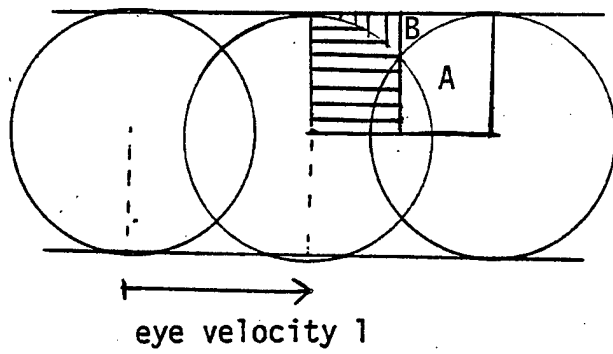

$$\text{Probability of detection} = \frac{A}{A + B}$$

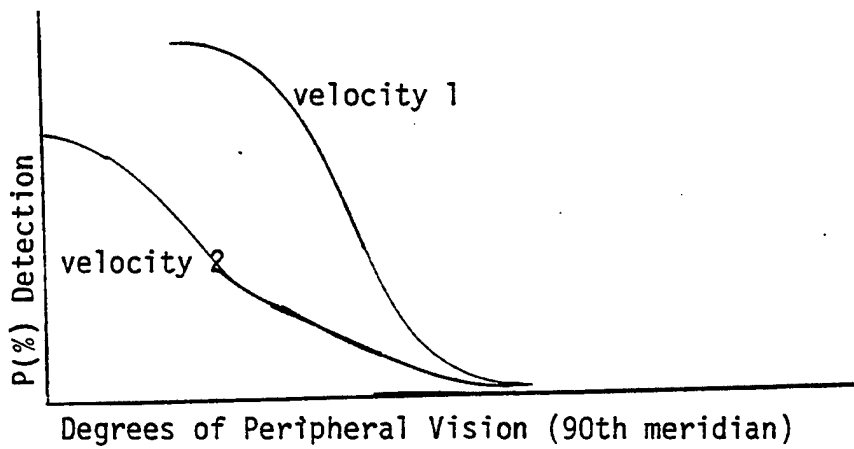

Figure 2

Figure 3 - Bloch's Law and variable size visual lobe theory.

Visual Lobes of Same Target

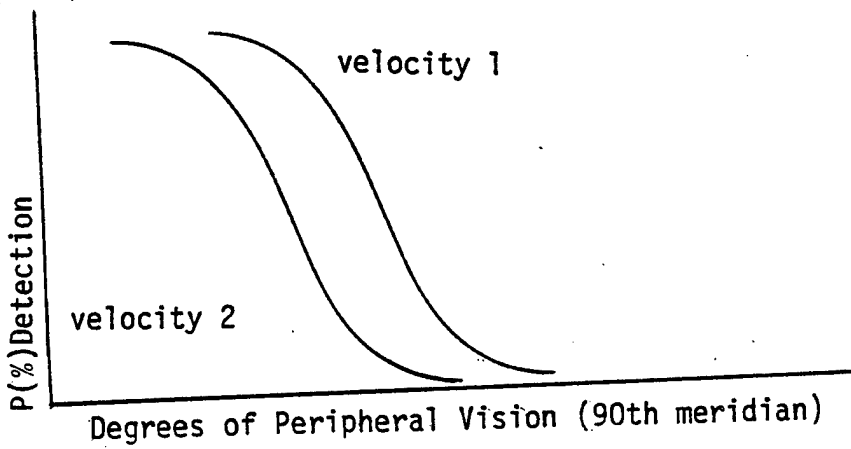
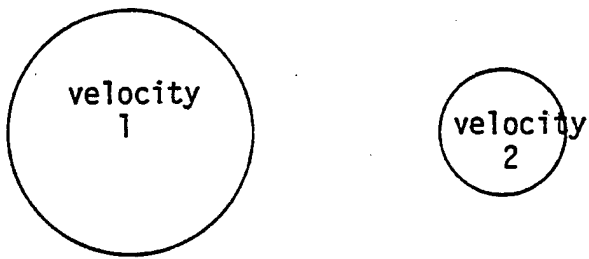

Figure 3A

Block's Law and Theoretical Results

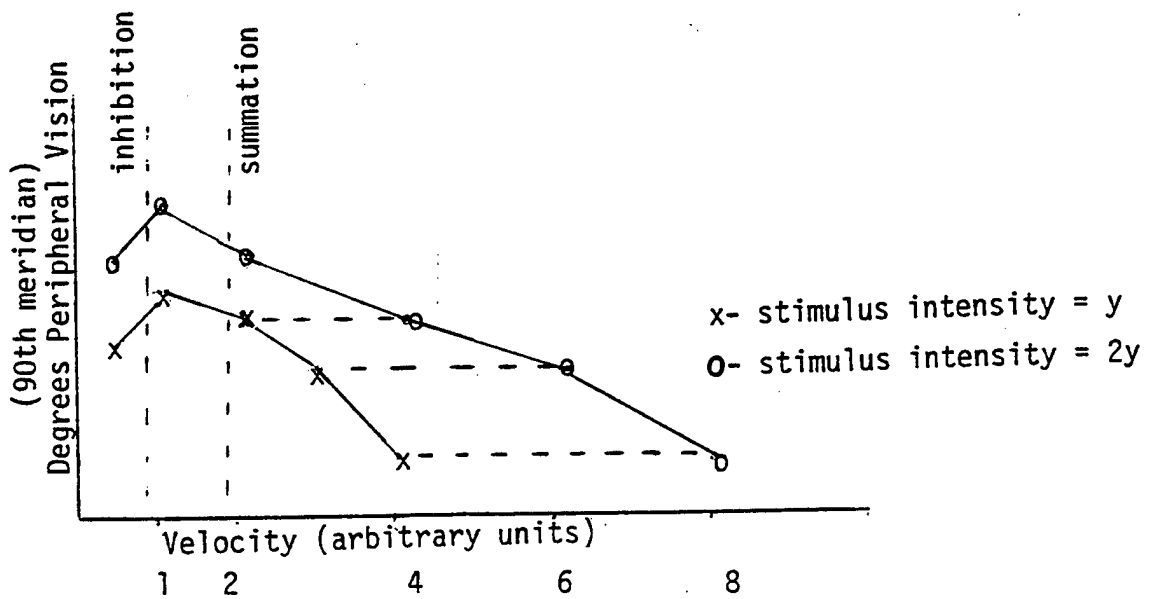

Figure 3B

between successive film exposures, it would not be recorded. For a spot moving with a uniform linear velocity during a film exposure, the event would be recorded as an elongated spot or a line (image smear). The recorded luminance of this line would be reduced (compared to the static spot) but fairly uniform.

If the visual system were comparable to a video camera principle, a similar moving spot would also be recorded for a single frame as an elongated spot or line. However, unlike the film exposure, the luminance of the elongated spot would not be uniform. The luminance of the elongated spot in the opposite direction of movement would be less, decreasing in an exponential value for a linear distance of movement. This decrease in luminance is a function of phosphor decay in a video system.

Wolkmann (1962) found a .5 log increase in threshold of a spot of light stimulus with saccadic eye movements, and plotted the data with the probability of detection versus log stimulus intensity with and without eye movements. Her probability curves would support the second possibility (Fig. 3) that the visual lobe is continuous but reduced in size with saccadic eye movements.

Starr (1969) found similar visual suppression with saccadic eye movements, but found no suppression with smooth pursuit eye movements. The test flash used, however, illuminated the whole field of view. Smooth pursuit eye movements might produce Fig. 2, but no suppression if the successive glimpses were sufficiently overlapped. A mixture of rapid pursuit and saccadic movements would give a mixed response. Recordings of eye movements (Yarbus, 1967) show that during visual

fixation on a stationary point, the eyes continue to move in small drifts and saccades.

E. The Purpose of Study

The purpose of this study was to determine the effect of pursuit eye movement velocity and prior saccadic eye movement on the size of the visual detection lobe compared to standard kinetic and static perimetry results. The experimental conditions of target size, background luminance, and contrast were used so that theoretical calculations could be compared with actual detection time data.

The data obtained from a moving fixation point may be used in the development of a device and technique of measuring the visual detection lobe for a given stimulus in laboratory and field environments where the number of variables and stimuli values can not be accurately quantified. However, the visual response for suprathreshold foveal stimuli can be expressed in degrees of peripheral vision to detection, which is a major factor in the probability of detection in search problems (Overington, 1976).

CHAPTER II

INSTRUMENTATION AND PROCEDURES

A. Approach

Peripheral visual fields are clinically measured with the subject fixating monocularly at a fixed point in an unstructured field, and the stimulus moved toward the fixation point or flashed at various locations.

In routine visual activity, however, a stimulus is detected with both eyes fixating after a saccade and/or moving in a pursuit manner and not necessarily directly towards the target.

In an absolute unstructured field, the eyes have nothing to fixate upon, and in searching the eyes and head would move according to the whims of the subject. The visual detection lobe for a particular target would be very difficult to measure in this manner. If a small fixation point is provided, the relationship between the eyes and target locations at detection can be determined. A fixation point will probably affect the visual detection lobe slightly, but the effect should be a constant for all stimulus conditions and provide comparative values for the variables examined. Two examples of applied search activities in relatively unstructured fields are pilots searching in a clear sky and seamen searching the ocean. In both examples the searched areas usually have large horizontal dimensions and smaller vertical ones. Therefore, the eye movements are predominantly horizontal with vertical steps at the lateral limits of the search area. With horizontal eye movements, a motionless target will enter

the visual detection lobe parallel to the eye movement and vertically displaced from the loci of the fixation points. Therefore, the vertical and horizontal meridians of visual field were measured with a target or the eyes moving in a horizontal direction at or vertically displaced from the fixation points.

B. Equipment and Arrangement (Fig. 4 and 5)

A list of equipment and model numbers appear in Appendix A.

C. Electronic Operation (Fig. 4)

For horizontal movement, a triangular shaped wave was selected on the signal generator as input to the scanner amplifier. The amplitude of the triangular wave was adjusted to produce 25 degrees of rotation on the optical galvanometer. One cycle at one hertz represented 50 degrees of mirror rotation and projected an image at 100 degrees per second. The position output from the scanner amplifier was connected to a sample hold amplifier and a digital voltmeter. A second scanner amplifier was connected to an optical galvanometer to produce vertical displacement of the target. The position output of the vertical scanner amplifier was connected to the digital voltmeter via a switch box.

The sample hold device and auxiliary circuitry provided the target location, controlled shutter operation, and triggered maximum signal amplitude for calibration. The sample hold device contained a quad 7400 Nand gate chip, three way switch, two position switch, subject push button input, and reset button. Two of the Nand gates were connected with the reset button to make a set-reset flip flop. One Nand gate was connected to the pulse out (TTL) output of the signal

Figure 4 - Electrical and optical schematic.

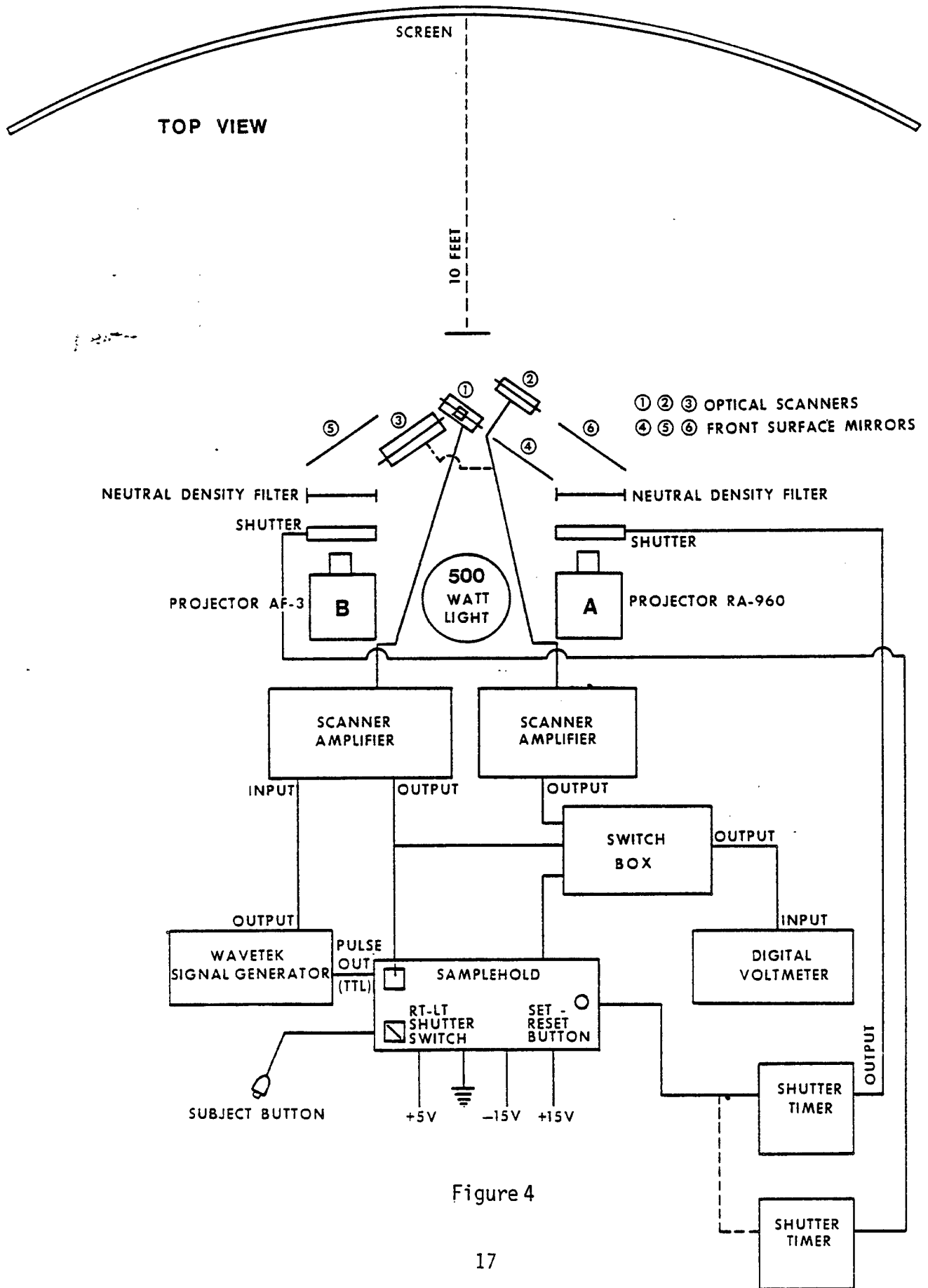

Figure 4

generator via a two-way switch which triggered the shutter drive unit at either the peak or trough of the triangular wave, and allowed either a left or right movement of the target per cycle. The fourth Nand gate was connected to the three way switch, the pulse out (TTL) of the signal generator, and the sample hold. In one position of the three position switch, the peak voltage from the scanner amplifier position output was displayed on the digital voltmeter. The second position measured the trough, and the third position was connected to the subject button.

D. Optical and Mechanical Operation (Fig. 5)

The target and fixation points were made with high contrast black and white, 35 mm film. Small black circles (approximately 2 mm) were placed on white typing paper and photographed from a distance of two to three feet. The resultant negatives were opaque with an almost flawless small circular clear area as examined with a microscope.

A sturdy optical table and stand were constructed with plywood and angle iron. The optical table was immediately above the subject's head. Shock absorbing material was placed under the projectors and optical benches to reduce vibration. The zoom lenses on the projectors were adjusted to produce 4.8 arc min targets which measured 4.25 mm at 3.05 meters (10 feet). The apertures of the electronic shutters were adjusted for proper nonfiltered target illumination. An adjustable optometric examining chair with head brace securely positioned the subject.

The background illumination source was a General Electric 500 watt frosted incandescent lamp, and was controlled with a rheostat.

Neutral density filters were made in 0.1 log steps using Kodak neutral density film and verified with a Beckman spectrophotometer.

Figure 5 - Physical equipment arrangement.

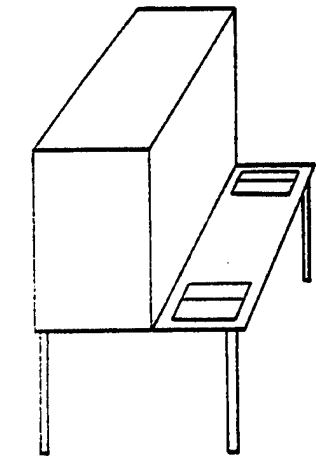

EXPERIMENTER'S TABLE AND INSTRUMENTATION

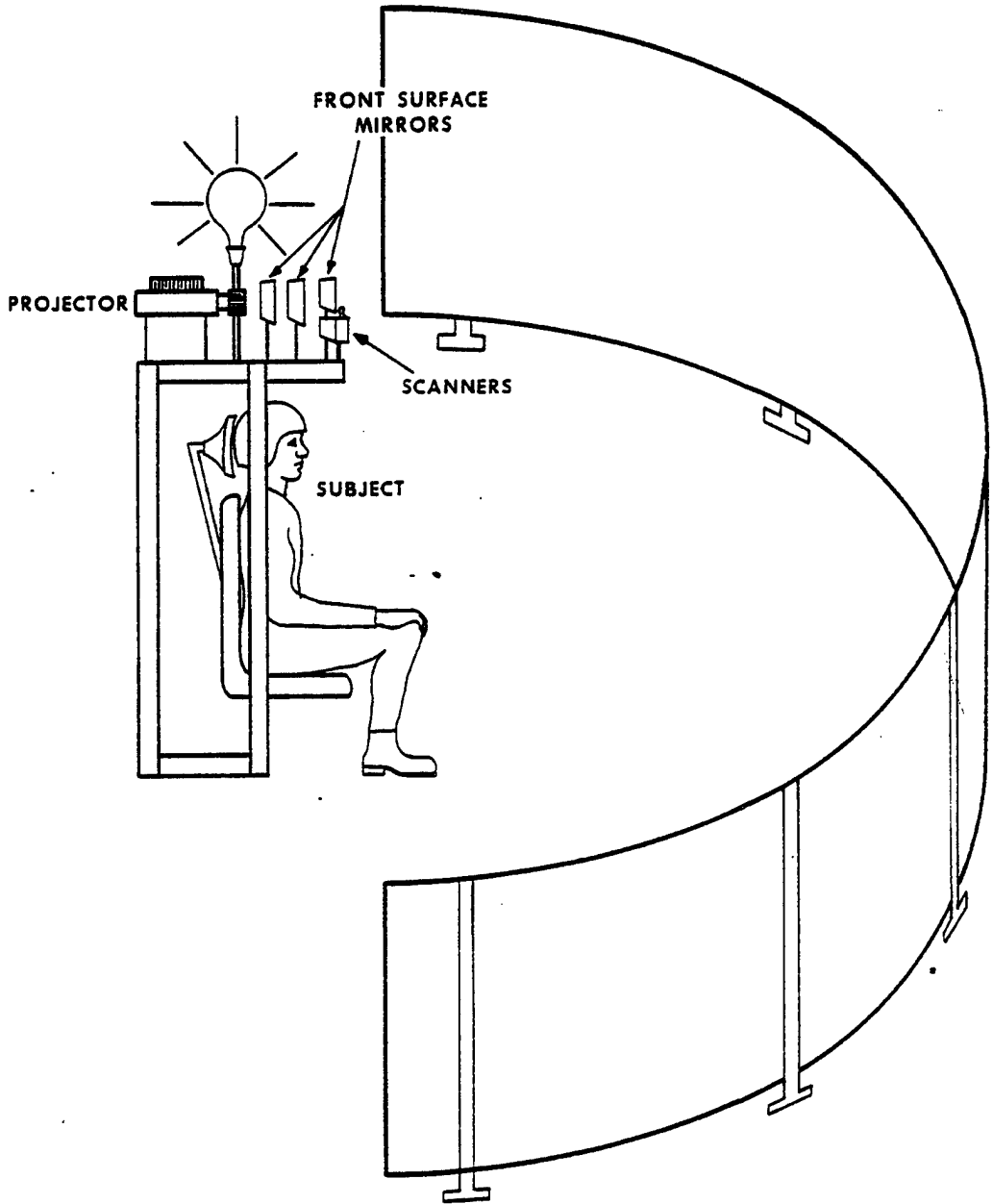

Figure 5

The screen was made with masonite boards and supported by 2x4's and 3/4" plywood ribs. The height of the semi-circular screen was 1.83 meters (six feet) with a diameter of 6.10 meters (20 feet). The screen was built in four forty-five degree horizontal sections and joined with joint tape and cracksealer. The screen's surface was primed with 3M's 915-P3 white and painted with 3M's Nextel Velvet 202-A1- white. With the single 500 watt background light source, no seams were visible to the subjects.

For Procedure I, the target slide was in projector A and the fixation point in projector B (Fig. 4). For Procedures II-IV, the target slide was in projector B and the fixation points in projector A. For Procedure I, the vertical movement of the mirror by the galvanometer was in position 3 (Fig. 4). For Procedure II-IV, the vertical galvanometer was in position 2. Horizontal movement by the other galvanometer was from position 1. Front surface mirrors 4 and 6 were used for projector A to project the image to the horizontally rotating mirror centered in position. The mirrors were shielded from the background illuminating source.

E. Calibration and Verification

Screen Luminance:

To achieve as near a uniformity of luminance as possible for the screen, the ceiling and floor immediately in front of the screen were covered with flat white art paper. The 500 watt background light source was moved on the stand to balance the luminance values of the right, left, and center portions of the screen. The height of the 500 watt light was above the mid-line of the screen which resulted in the upper part of the screen being slightly brighter than the lower

portion. To keep the contrast of the target constant, the target was moved horizontally only at the 3 foot level or vertical mid-point of the screen and the fixation points were moved vertically as necessary (Table 1). The luminance at the center of the screen was adjusted to 42.48 cd/m^2 at the beginning of the session.

Horizontal Target Location Calibration:

Using a reflex aircraft sight mounted on a protractor, the target position could be located in degrees from the center of the screen when viewed from the subject's chair. The offset control on the scanner amplifier moved the target and position output was displayed by the digital voltmeter in millivolts. The voltage was recorded for every 5 degree change in horizontal target position. The resulting relationship was 1 degree = .06 volts (Fig. 6). Linearity variation between voltage and degrees for the G-300 PD Optical Scanner is $\pm .15\%$.

Vertical Target Calibration:

The vertical movement of the target for the right and left projectors had different conversion values from voltage to degrees. The distance from the screen to the point of rotation of the right and left channel mirrors was slightly different, and changed slightly when the vertical galvanometer was moved. To achieve the vertical movement for the different procedures, one galvanometer had to be repositioned. The vertical conversion factors was recalibrated each time the mirror was moved. Since there was linearity between voltage and degrees, the target was moved at 30.5 cm (1 foot) intervals and corresponding voltage was recorded. The slope of linear regression between degrees and voltage was calculated for the conversion factor. The initial verification of vertical linear-

TABLE 1

CALIBRATION
Screen Luminance (cd/m²)

	22.5°	45°	67.5°	90° (center)	112.5°	135°	157.5°
1 FT from top of screen	44.5	43.1	42.8	42.5	41.9	42.3	42.8
2	44.6	43.5	43.1	42.9	42.5	42.5	43.0
3 (center)	43.5	42.9	42.4	42.5	42.0	42.0	41.9
4	42.2	41.9	41.7	41.5	42.3	41.2	40.2
5	40.5	40.5	40.4	40.5	40.1	39.8	38.8

Percent difference between center of screen luminance and:

Mean = 42.0 cd/m²
S.D. = 1.30

1. Lowest value - 42.5 vs 38.8 = 8.71%
2. Highest value - 42.5 vs 44.6 = 4.94%
3. Lowest value 42.5 vs 42 = 1.18% within 45° from horizontal center
4. Highest value 42.5 vs 42.9 = .94% within 45° from horizontal center

Figure 6 - Optical scanner calibration (horizontal).

OPTICAL SCANNER CALIBRATION

HORIZONTAL (VOLTAGE VS DEGREES)

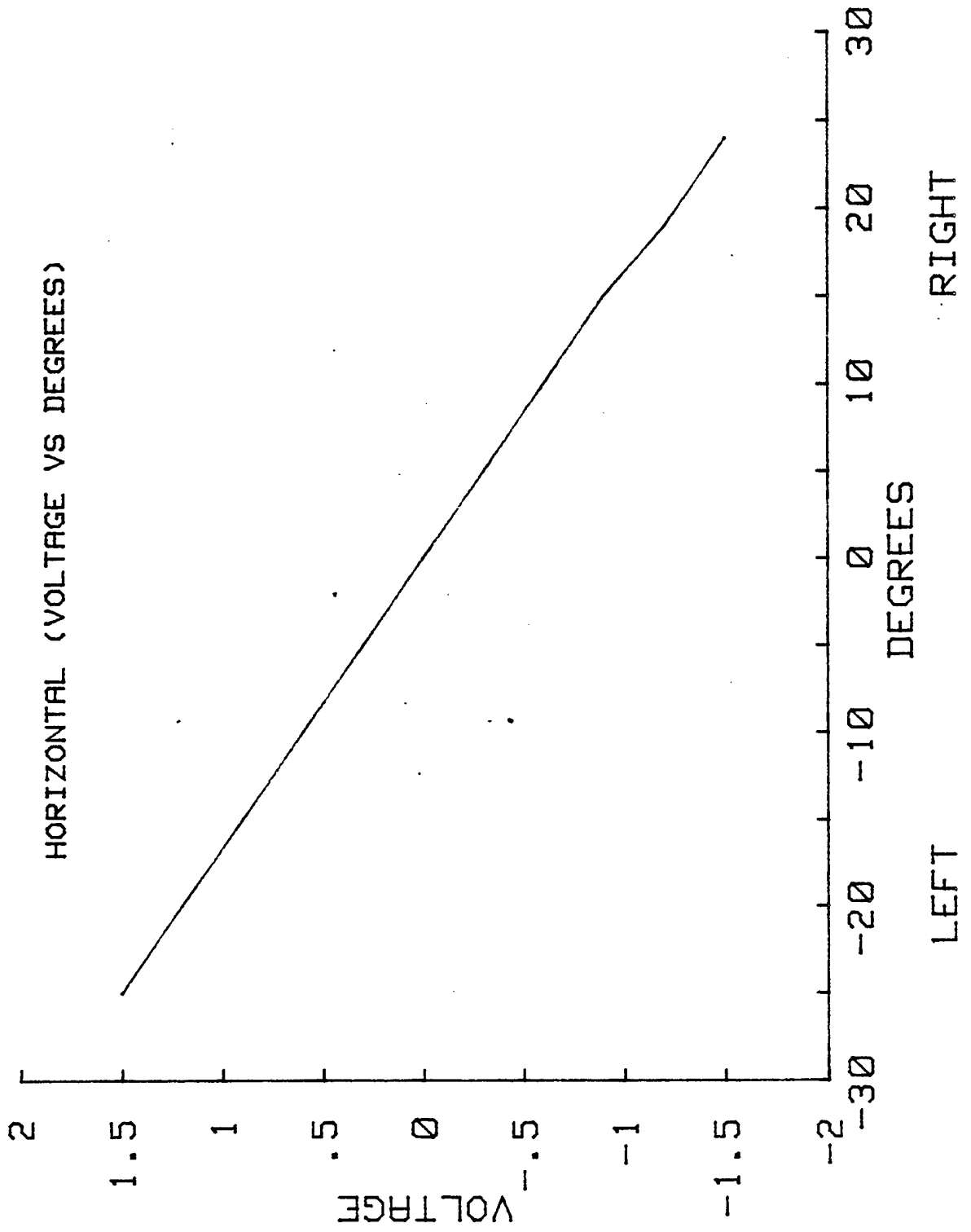

Figure 6

ity between voltage and degrees was determined for each channel at thirty-two points or every 5.08 cm (2 inches) (Fig. 7A & 7B).

Target Luminance and Size:

The target size was set at 4.8 arc min or 4.25 mm at 3.05 meters (10 feet). The luminance was measured with a Pritchard Spectra Photometer using the 2 arc min aperture. The luminance was adjusted at the beginning of each session to provide 68% contrast with no filters in the optical system. This allowed for a constant luminance for each experiment which was varied by ND filters.

Neutral Density Filters:

Neutral Density Filters were made with Kodak neutral density film in .1 log unit steps. The percent transmission was measured with the Beckman spectrophotometer.

Using the Pritchard Spectra Photometer, the target luminance was measured on the screen for each neutral density filter with the complete optical arrangement. The background luminance was set at 42.5 cd/m^2 and the contrast determined (Table 2).

F. Variables Examined:

The target size was 4.8', (4.25 mm at 3.05 meters). The background luminance was in the photopic range and held constant at 42.48 cd/m^2 (12.4 ft-L). The targets and fixation point were moved only horizontally. Target and fixation point velocities used: 1, 2, 4, 8, 12, 16, and 20 deg/s. Five constant levels were selected: .27, .34, .43, .54, and .68. Contrast is defined as $(L_t - L_b) / L_b$; where L_t =Luminance of target and L_b =Luminance of background. Four primary meridians were measured: 0th, 90th, 180th and 270th (Fig. 9). Five Trials were ob-

Figure 7 - Optical scanner calibration (vertical).

OPTICAL SCANNER CALIBRATION

VERTICAL (VOLTAGE VS DEGREES) RIGHT CHANNEL

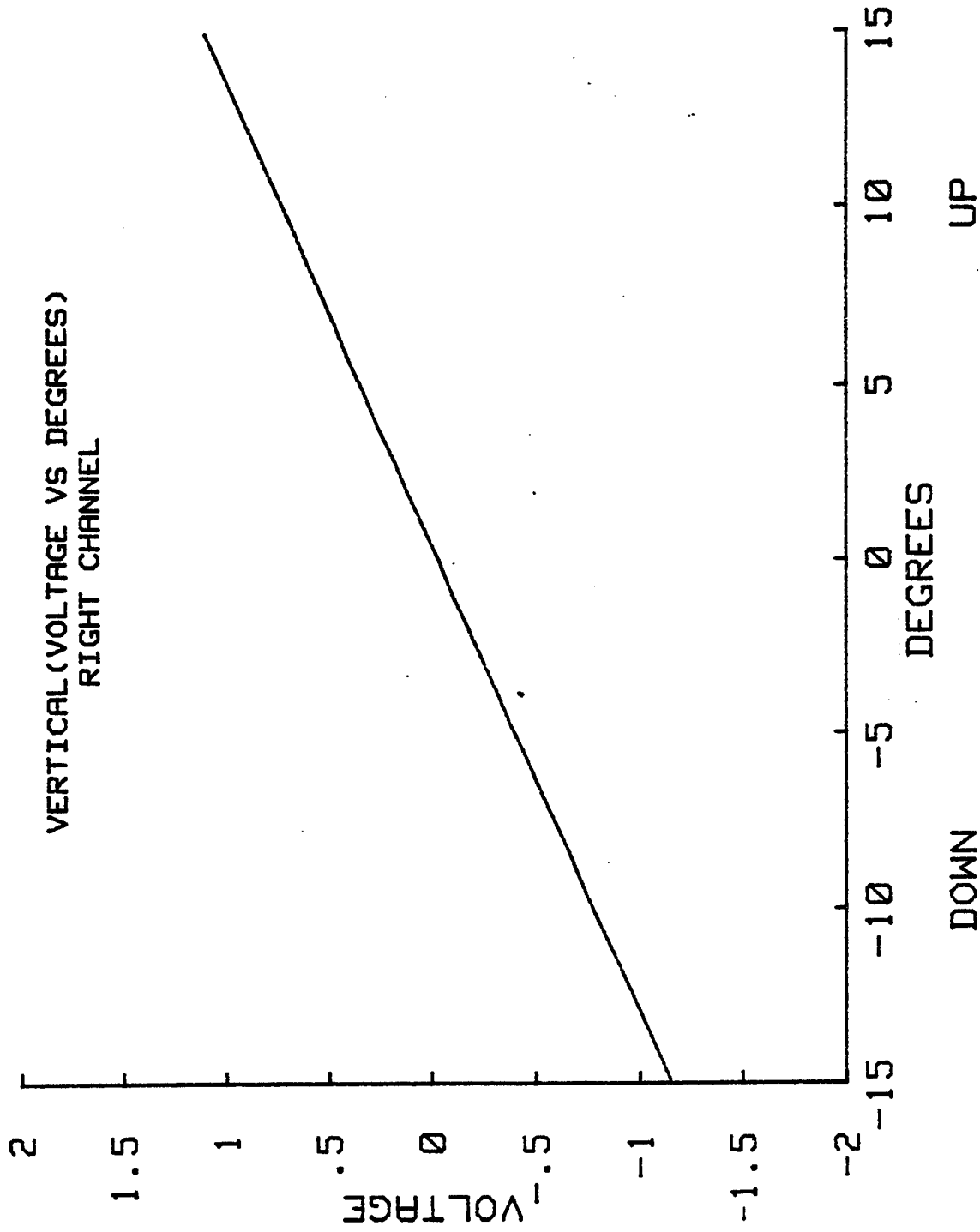

Figure 7A

OPTICAL SCANNER CALIBRATION

VERTICAL (VOLTAGE VS DEGREES)
LEFT CHANNEL

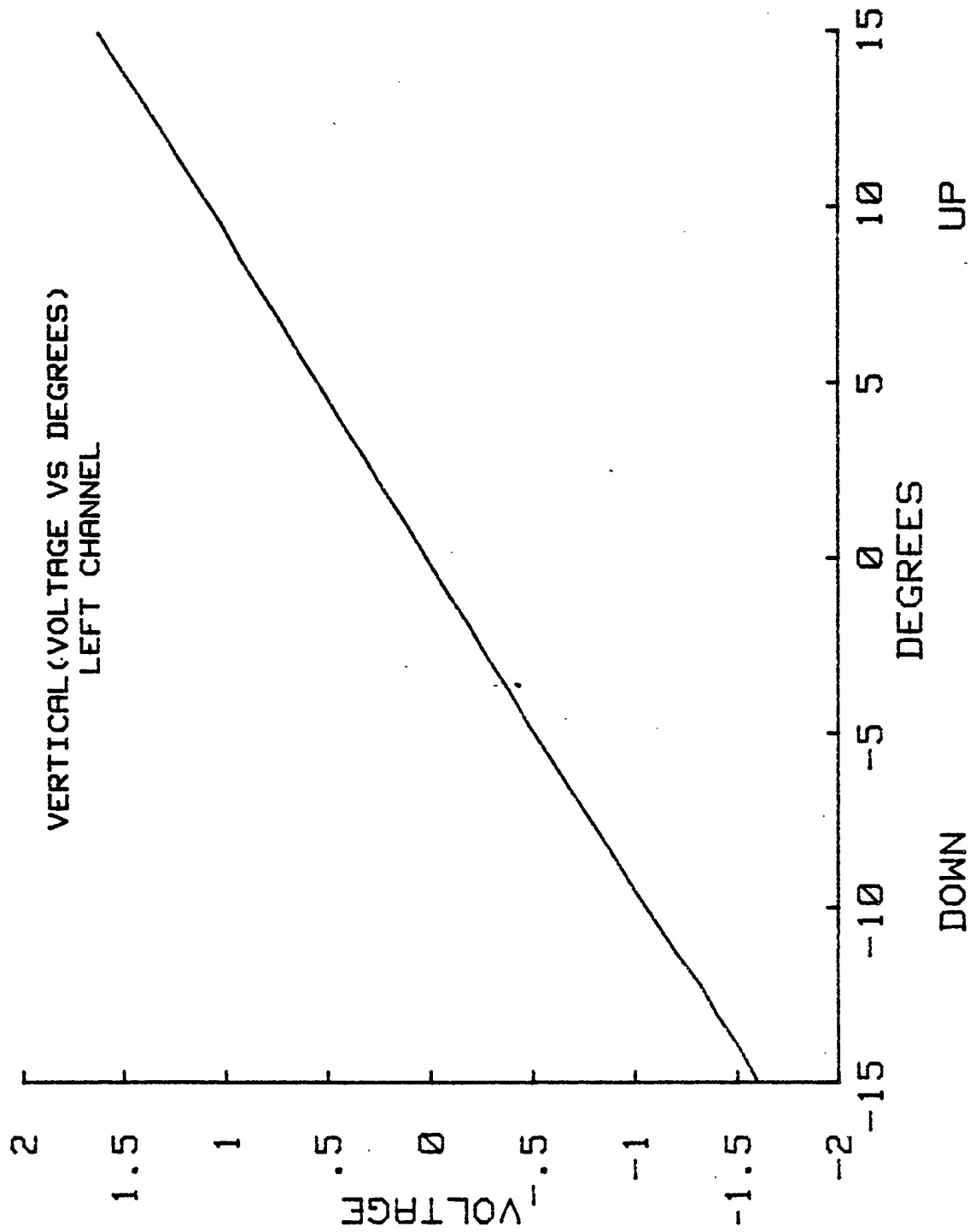

Figure 7B

TABLE 2

Neutral Density Filter Transmissions, Target Luminance
and Contrast Determinations

Log Filter	0	.1	.2	.3	.4
Calculated % Transmission	100%	79.4%	63.1%	50.1%	39.8%
Measured % Transmission	100%	79.7%	62.7%	47.6%	37.1%
Target Luminance (cd/M ²)	72.3	65.5	61.1	56.5	53.4
Desired Contrast	68%	54%	43%	34%	27%
Measured Contrast	70%	54%	44%	33%	26%

tained for each experimental condition. Because of the duration of time required to complete the procedures, two subjects were given three contrast and four velocity values. The means, standard deviation, correction factors, and calibration values for each subject, procedure, meridian, velocity, and contrast value are found in Appendix B.

G. Subjects

The subjects used in this study were three faculty members and one graduate student, who were familiar with psychophysical experiments. All subjects had shown normal stereopsis in previous binocular evaluations. Three subjects were low myopes, requiring spectacles. Their distant visual corrections and resultant activities were as follows:

BM O.D. - 2.75 sph - corrected to 20/15
O.S. - 2.00 sph - corrected to 20/15

DP O.D. - .75 - 2.50 x 15 - corrected to 20/20
O.S. - .75 - 1.75 x 180 - corrected to 20/20

RH O.D. - 2.00 - .50 x 165 - corrected to 20/15
O.S. - 2.00 - .50 x 5 - corrected to 20/15

One subject was emmetropic (DH) with 20/15 unaided visual acuity in each eye. The ages of the subjects were BM-39, RH-40, DP-54, and DH-30.

H. Description of Procedures

Procedure I - Moving Target:

For the 90th and 270th meridian (Fig. 8), the subject looked at a fixation point binocularly and the target moved horizontally above or below the fixation point. Between trials the fixation point was moved vertically. The target always traveled in the middle of the screen to minimize target contrast fluctuations from vertical variations of the luminance of the screen. The target was initially presented at eccentricities at which it was not detected and progressed in approximately

Figure 8 - Visual field meridians.

FOUR PRIMARY MERIDIANS

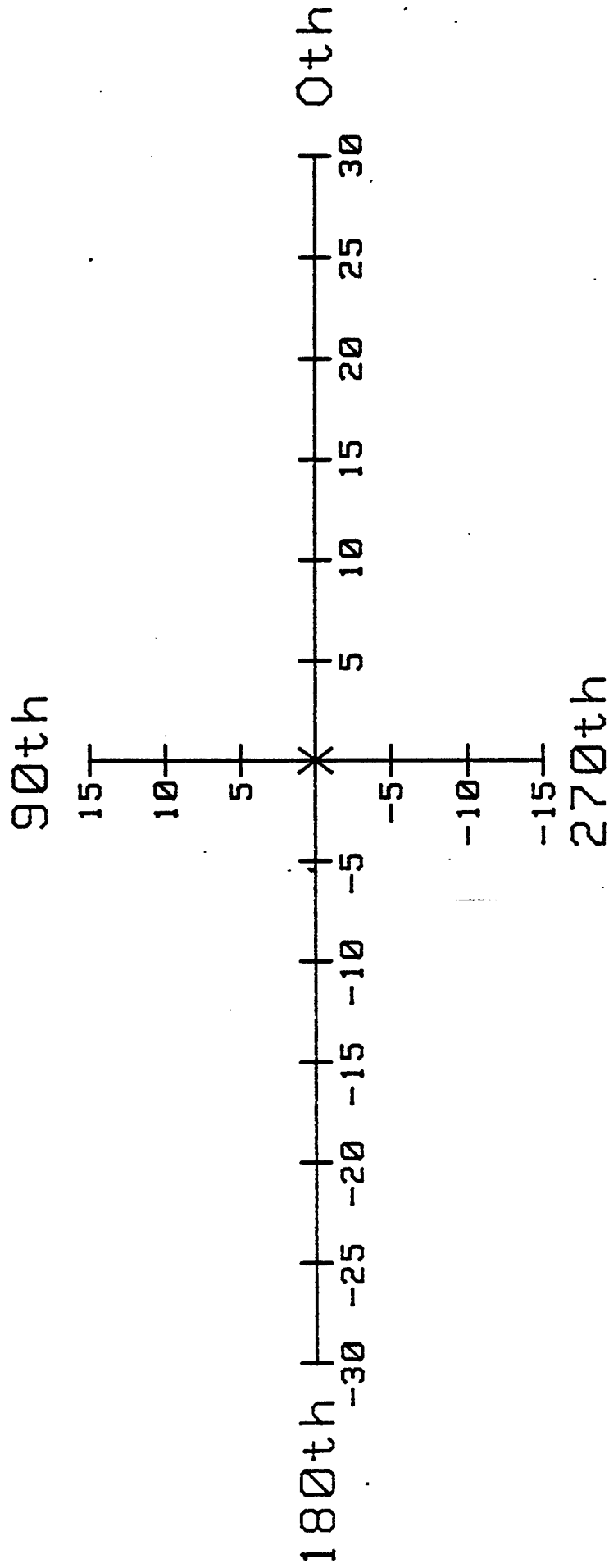

Figure 8

1° steps toward the fixation point until it was perceived. Between trials the subject looked at pictures below the screen. At the beginning of a trial the experimenter cued the subject to look at the fixation point.

For the 0th and 180th meridian the fixation point was placed vertically at the same level as the moving target. The experimenter cued the subject with a command of "ready" at which time the subject looked at the fixation point. The target was then moved towards the fixation point, and the subject pressed a subject button when the target was detected.

Procedure II - Stationary Target:

For the 90th and 270th meridian, the subject looked binocularly at a moving fixation point and detected a stationary target. The fixation point moved horizontally in approximately 1° steps above or below the centered target. Between trials the subject looked at pictures and was cued before the beginning of a new trial as in Procedure I.

For the 0th and 180th meridian, the target was placed in the center of the screen and the fixation point moved horizontally towards the stationary target. When the target was detected, the subject depressed the subject button.

Procedure III - Saccadic Eye Movement:

For the 90th and 270th meridian the target was placed in the center of the screen and two horizontal fixation points were placed above or below the target. The fixation points were separated six degrees with the target directly above or below the right fixation point. The subject made a saccadic eye movement binocularly from the left to the right fixation point and reported whether the target was seen or not seen. The

experimenter instructed the subject to look at the left fixation point. When the sound of the shutter opening was heard, the subject moved his fixation to the right fixation point as quickly as possible. The target was exposed for .7 seconds.

For the 0th meridian the fixation points were placed to the left of the target and the subject made a saccadic eye movement from left to right. For the 180th meridian the fixation points were placed to the right of the target and the subject made a saccadic eye movement from right to left.

Procedure IV - Flashed Target

The target was located in the center of the screen and flashed for .6 seconds. The fixation point was moved above, below, right and left of the target for the four meridians in approximately 1° steps towards the target until the subject reported a positive response. Five trials were taken for each contrast value. The subject was given a "ready" command prior to each presentation.

CHAPTER III

RESULTS

With four procedures and four subjects a total of 3985 measurements were taken. Five measurements were made for each stimulus condition. The mean and standard deviation for each stimulus condition, procedure, meridian, and subject are calculated from calibration and correction factors and tabled in Appendix B (Page 101).

A. Meridian Plots for each Subject and Procedure

The means of the data points were graphed and tabled with ± 1 standard deviation according to subject, procedure, and meridian (Appendix C), page 140. The independent variable (X-axis) and dependent variable (Y-axis) are reversed in the plots to extend the peripheral vision scale and provide spacing for the tables above the graphs. The standard deviation values in the meridian tables are relatively small and usually less than one degree for all subjects, procedures, and vertical meridians (90th and 270th). The standard deviations of the horizontal meridians (0th and 180th) are generally larger, but usually less than two degrees. There are several explanations. The method of limits was used on the vertical meridians and the method of constant stimuli with a reaction time correction factor for the horizontal meridians with the two dynamic procedures (I and II). The binocular horizontal visual field is larger than the vertical and includes the blindspot of one eye between 11 and 18 degrees. The stimuli were not randomized for velocity or contrast.

Decreasing contrast reduced the size of the visual field. In the dynamic procedures, increasing velocity of either the target or fixation point also decreased the visual field size and always occurred at a velocity beyond four degrees per second for all subjects. Insufficient data were taken in the lower velocities to determine exactly at what velocity the field began to reduce. For subjects BM and DP the visual field was usually reduced from the lowest velocity taken of 1 degree per second, with an occasional increase at 2 degrees per second.

With the two static procedures (III and IV) the sensitivity of the binocular fields for a given contrast value shows the horizontal meridians (0th and 180th) to be similar. The upper meridian (90th) is smaller than the lower one (270th). With Procedure III and IV, a definite change in retinal sensitivity function occurs with a change in contrast beyond approximately 13 degrees from the fovea for horizontal meridians for subjects BM and RH. Subject DH showed similar changes with Procedures I and II beyond 15 degrees. This flattening of the retinal sensitivity response beyond 15 degrees is characteristic of the normal visual field. (Harrington, 1964; Aulhorn, 1972; Sloan, 1961; Tate, 1977).

B. Vertical and Horizontal Relationship of the Visual Fields

The four meridians were plotted for each subject and procedure, and appear in Appendix C. Averaged fields of the four subjects for the four procedures are plotted in Figures 9 to 12 with meridian means and standard deviations in Table 3. Only the 43% contrast targets are averaged for the four subjects for the dynamic procedures (I and II). An increase in target velocity for the dynamic procedures (I and II) decreased the size of the visual fields, and a decrease in

Figure 9 - Plot of four meridians for moving target procedure
at 43% contrast.

VELOCITY
1°/s = 1
4°/s = 2
8°/s = 3
16°/s = 5

CONTRAST=43%
4 SUBJECTS
MOVING TARGET

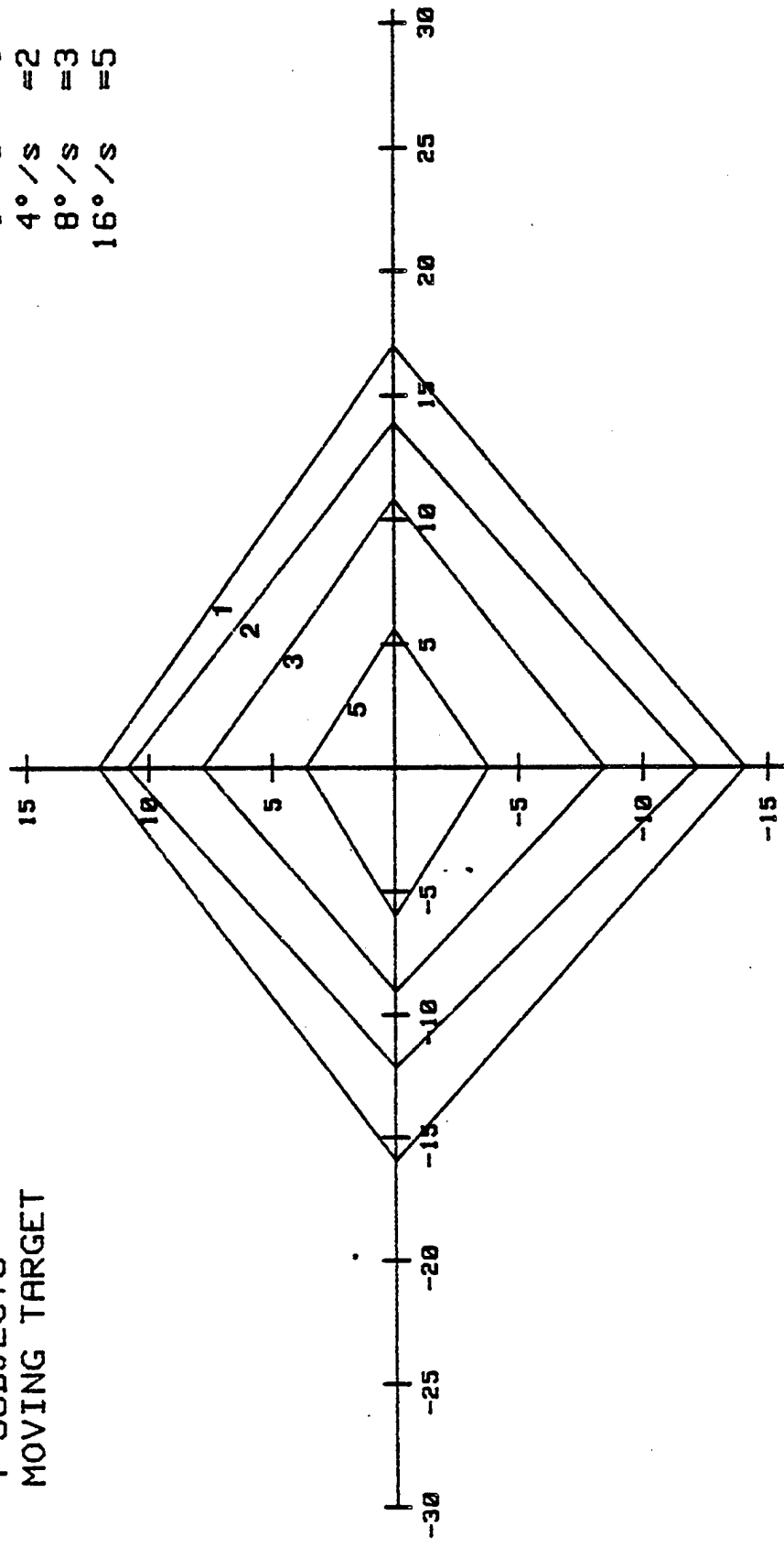

Figure 9

Figure 10 - Plot of four meridians for fixed target procedure
at 43% contrast.

VELOCITY
 1°/s = 1
 4°/s = 2
 8°/s = 3
 16°/s = 5

CONTRAST=43%
 4 SUBJECTS
 FIXED TARGET

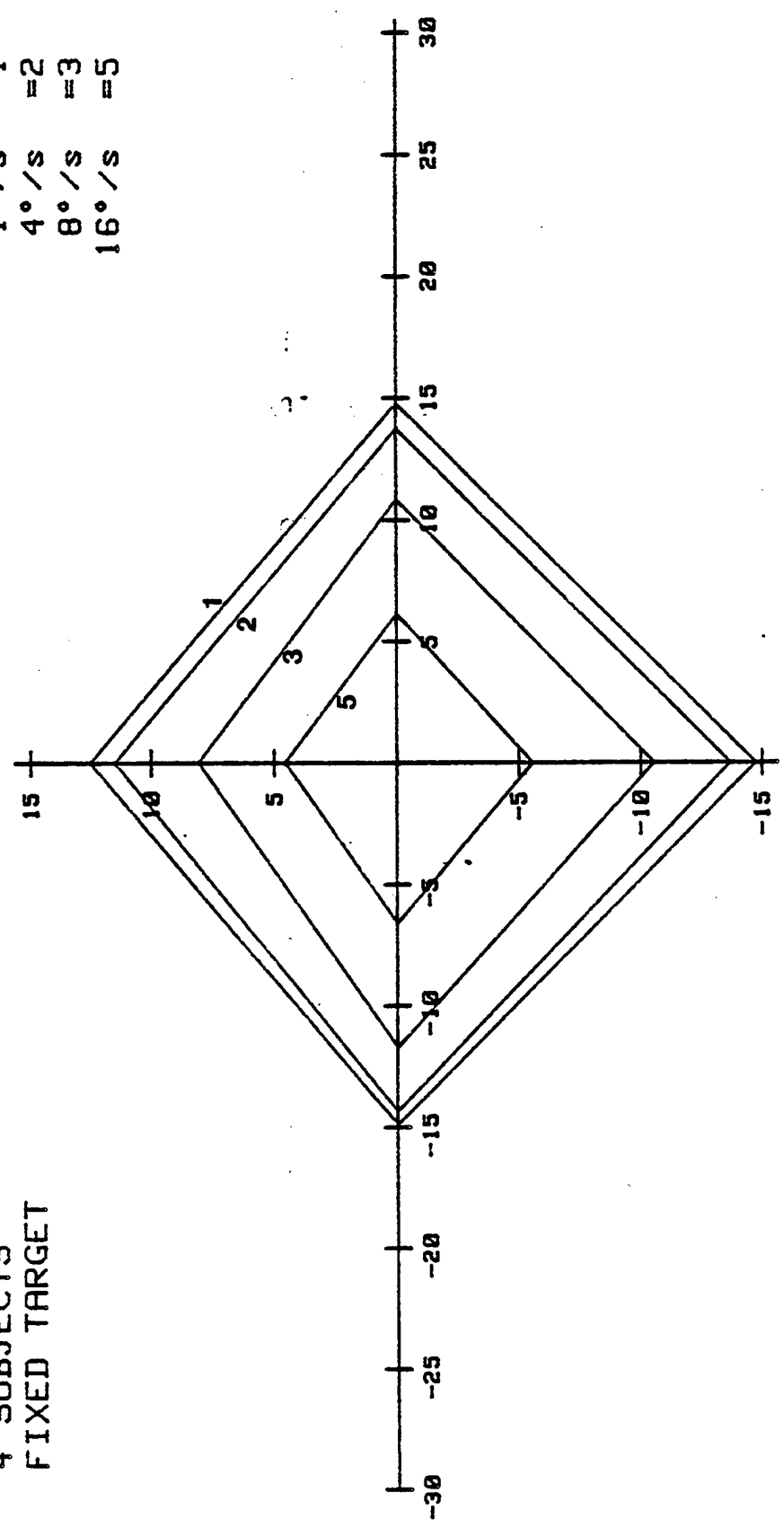

Figure 10

Figure 11 - Plot of four meridians for saccadic move procedure.

4 SUBJECTS
SACCADIC MOVE

CONTRAST
27%=1
43%=2
68%=3

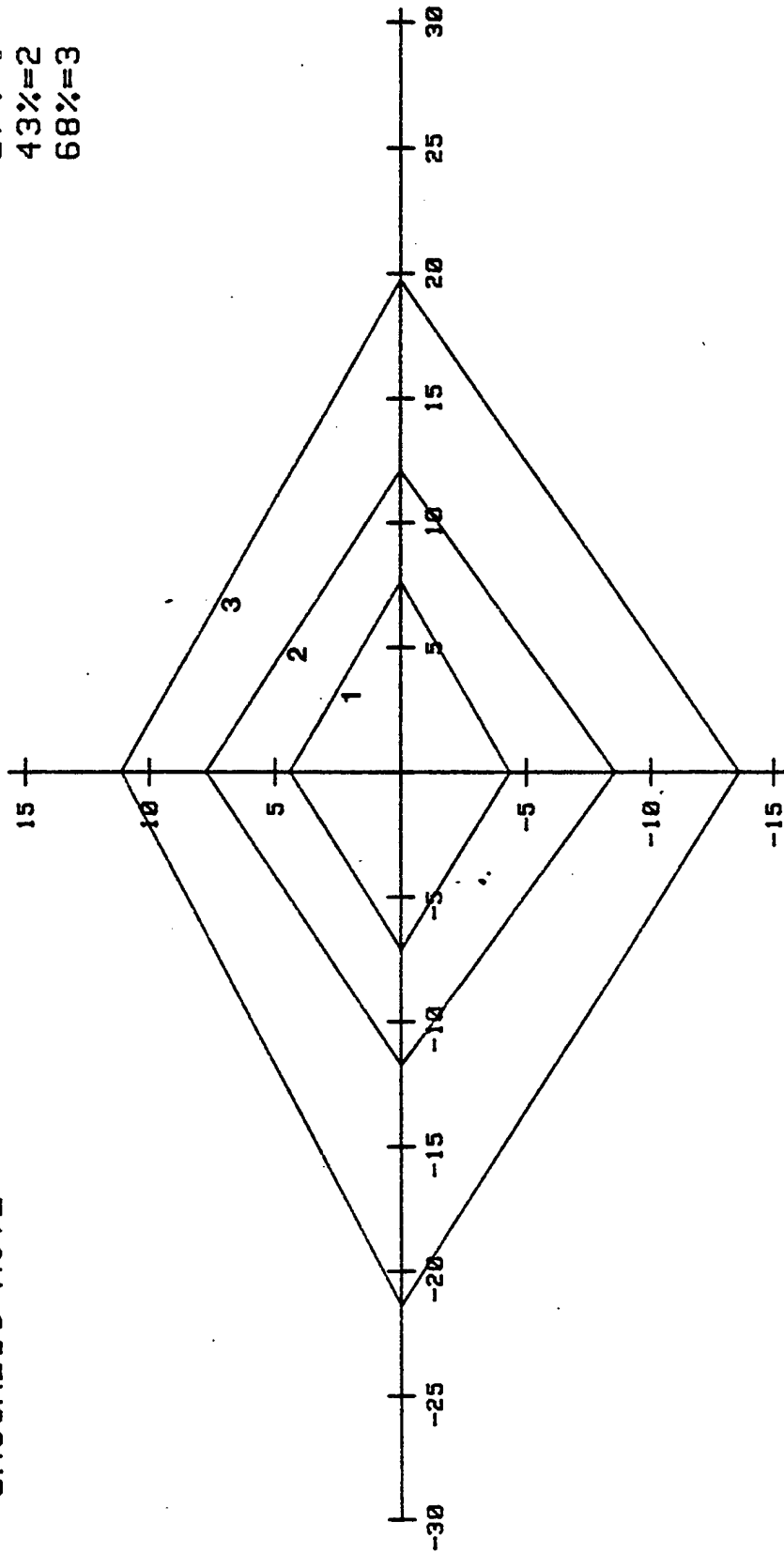

Figure 11

Figure 12 - Plot of four meridians for flashed target procedure.

4 SUBJECTS
FLASHED TARGET

CONTRAST
27%=1
43%=2
68%=3

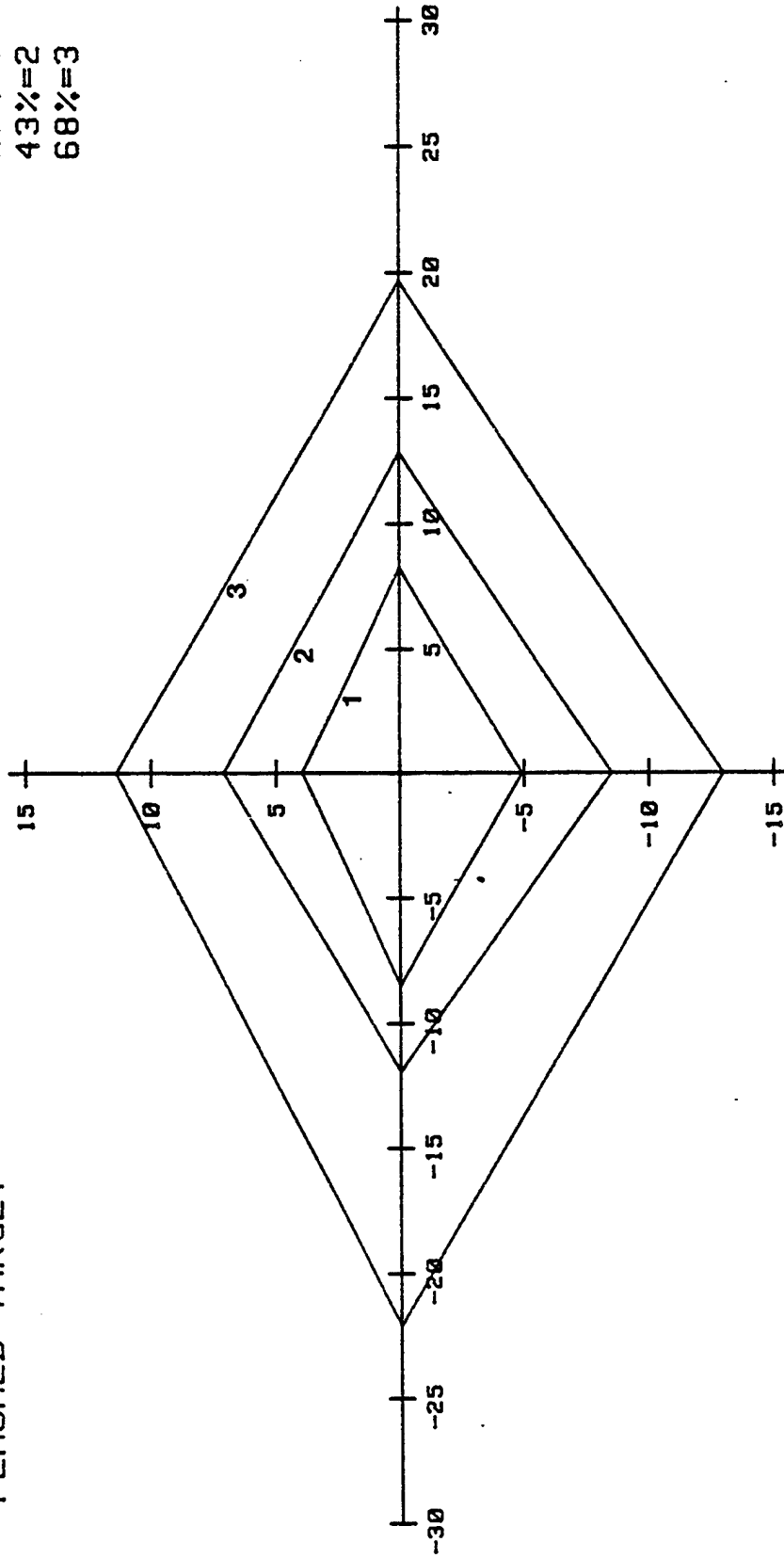

Figure 12

TABLE 3

Dynamic Procedures
 Averaged meridian size in degrees and ± 1 standard
 deviation for four subjects at 43% contrast

		<u>Moving Target - Procedure I</u>			
		Meridian			
Velocity		270th	90th	0th	180th
1°/s	Mean	14.07	12.04	17.01	15.97
	S.D.	.71	.43	4.14	4.08
4°/s	Mean	12.19	10.85	13.91	12.16
	S.D.	1.35	.24	2.23	1.76
8°/s	Mean	8.48	7.78	10.81	9.07
	S.D.	2.72	2.17	2.56	1.99
16°/s	Mean	3.74	3.66	5.60	6.01
	S.D.	2.57	1.69	2.59	2.24
		<u>Fixed Target - Procedure II</u>			
		Meridian			
Velocity		270th	90th	0th	180th
1°/s	Mean	14.76	12.50	14.77	14.91
	S.D.	.89	1.36	1.75	.24
4°/s	Mean	13.71	11.49	13.73	14.35
	S.D.	1.01	1.64	2.00	1.91
8°/s	Mean	10.56	8.05	10.85	11.72
	S.D.	.88	1.14	3.00	1.16
16°/s	Mean	5.59	4.55	6.14	6.60
	S.D.	2.01	1.54	2.73	1.95

NOTE: Table continued on following page.

TABLE 3 (Continued)

Static Procedures
 Averaged Meridian size in degrees and ± 1 standard
 deviation for four subjects

<u>Saccadic Move - Procedure III</u>					
		Meridian			
Contrast		270th	90th	0th	180th
68%	Mean	13.60	11.11	19.74	21.39
	S.D.	1.28	1.69	5.13	7.93
43%	Mean	8.55	7.75	12.11	11.78
	S.D.	2.07	.83	1.62	2.10
27%	Mean	4.36	4.42	7.65	7.11
	S.D.	1.39	.71	2.81	3.26
<u>Flashed Target - Procedure IV</u>					
		Meridian			
Contrast		270th	90th	0th	180th
68%	Mean	12.98	11.39	19.68	22.11
	S.D.	1.49	.84	6.84	8.07
43%	Mean	8.51	7.11	12.86	11.95
	S.D.	.57	1.14	1.34	.84
27%	Mean	4.92	3.96	8.25	8.51
	S.D.	.63	.68	1.52	1.42

contrast also decreased the visual fields in a similar manner for the static procedures (III and IV).

Although an increase in velocity decreased the size of the visual fields in the dynamic procedures for a given contrast value, the dynamic procedures produced visual fields larger than the static procedures for a given contrast at velocities less than 8 deg/s. A description of individual four meridian and plots (Appendix D) follows.

Subject DH showed very similar fields and symmetry for all procedures for the conditions plotted. Subject RH showed similar results except for Procedure II (Fixed Target) where the vertical meridians show almost equal sensitivity to the horizontal meridians. Subject DP showed a skewness of the field for Procedure III (Saccadic Move) to the right, which is not seen on the other procedures. This could be explained by either constant overshoot of saccadic eye movements to the right or either a delay or undershoot of movements to the left. The Fixed Target procedures also produced smaller visual fields than the moving targets procedure for an equivalent stimulus value for subject DP. Subject BM showed a skewness of the field for Procedure II (Fixed Target) to the left, which was not seen on the other procedures. This might be explained by subject BM slightly leading the moving fixation on pursuit movements to the left or lagging on movements to the right.

C. Relative Size of the Visual Fields

The relative size of the visual fields are graphed among the subjects for each procedure (Figures 13-17). Only the 43% contrast field is plotted for Procedures I and II. The area of the visual field is expressed by the following equation: $(270^{\text{th}} \text{ and } 90^{\text{th}}) (180^{\text{th}} \text{ and } 0^{\text{th}})/2;$

Figure 13 - Plot of calculated area of visual fields
for Procedure I for each subject.

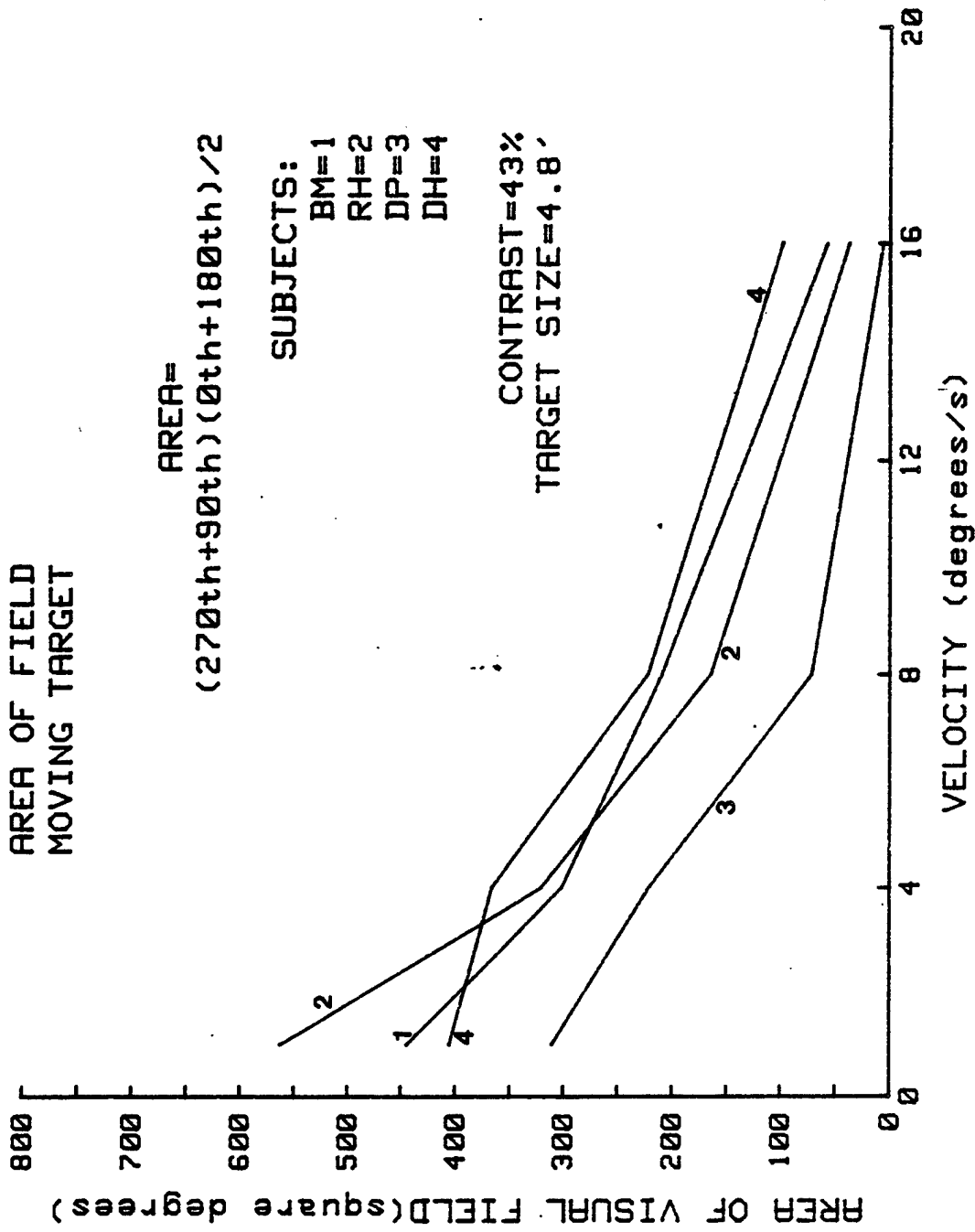

Figure 13

Figure 14 - Plot of calculated area of visual fields for
Procedure II for each subject.

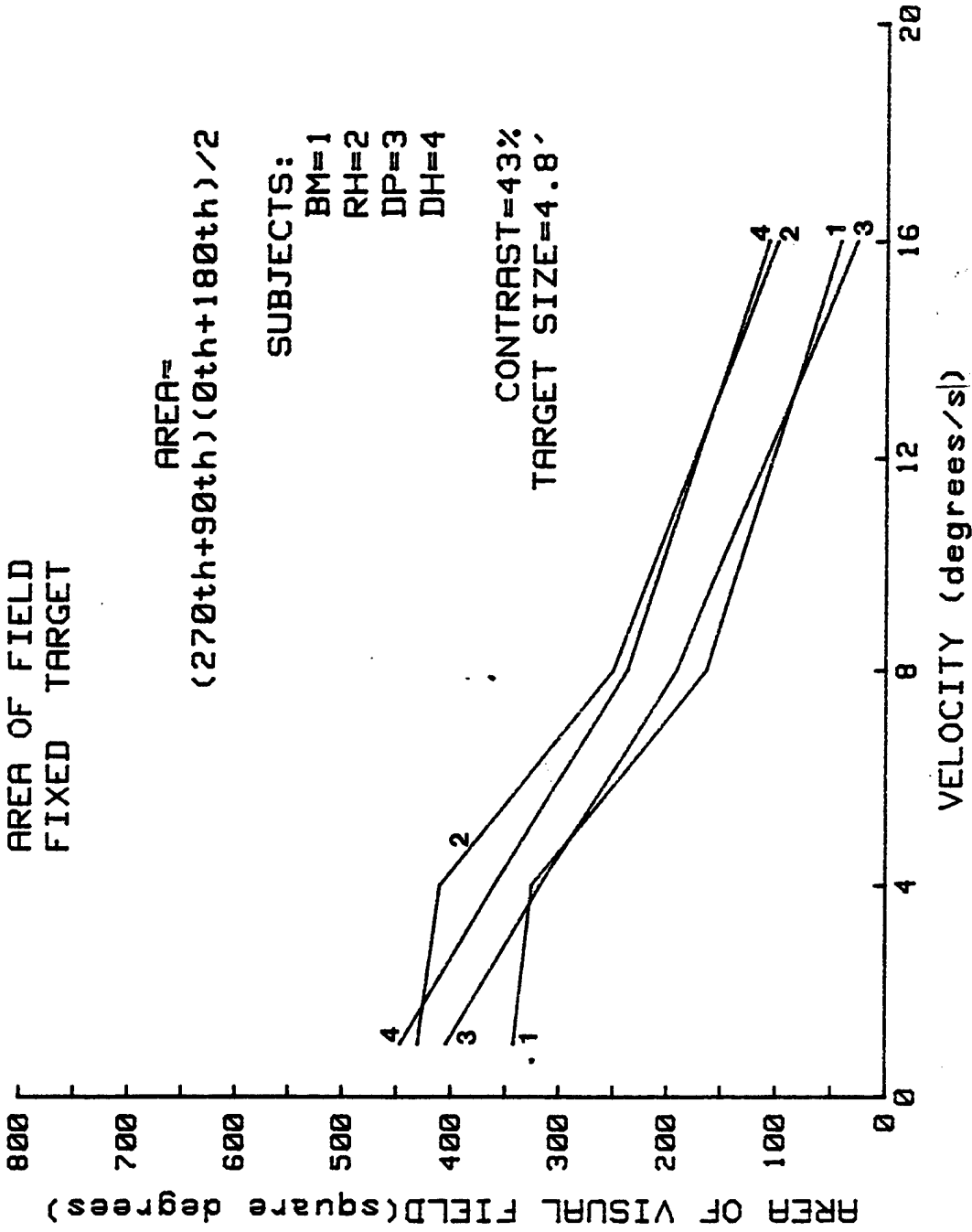

Figure 14

Figure 15 - Plot of calculated area of visual fields
for Procedure III for each subject.

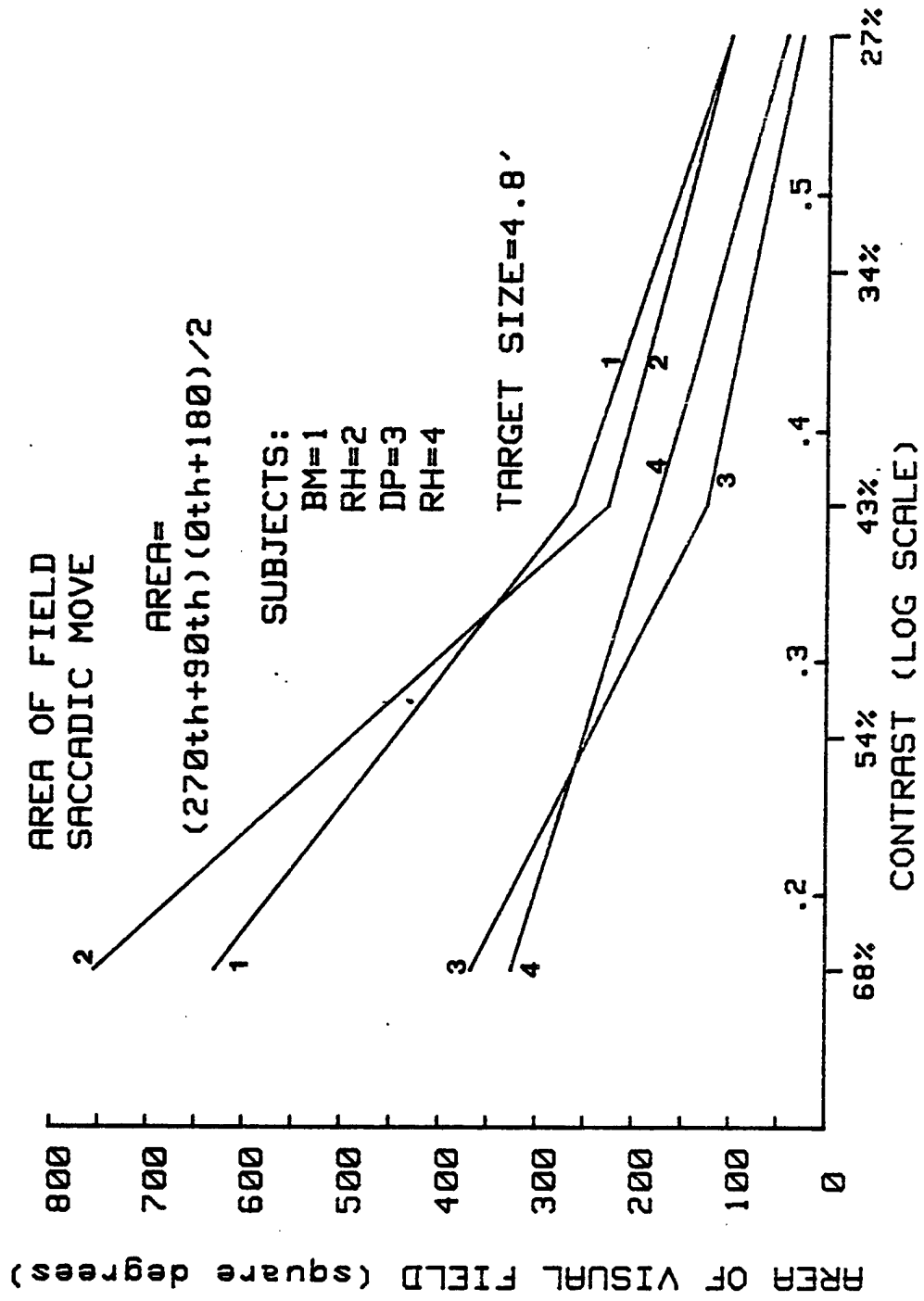

Figure 15

Figure 16 - Plot of calculated area of visual fields for Procedure IV.

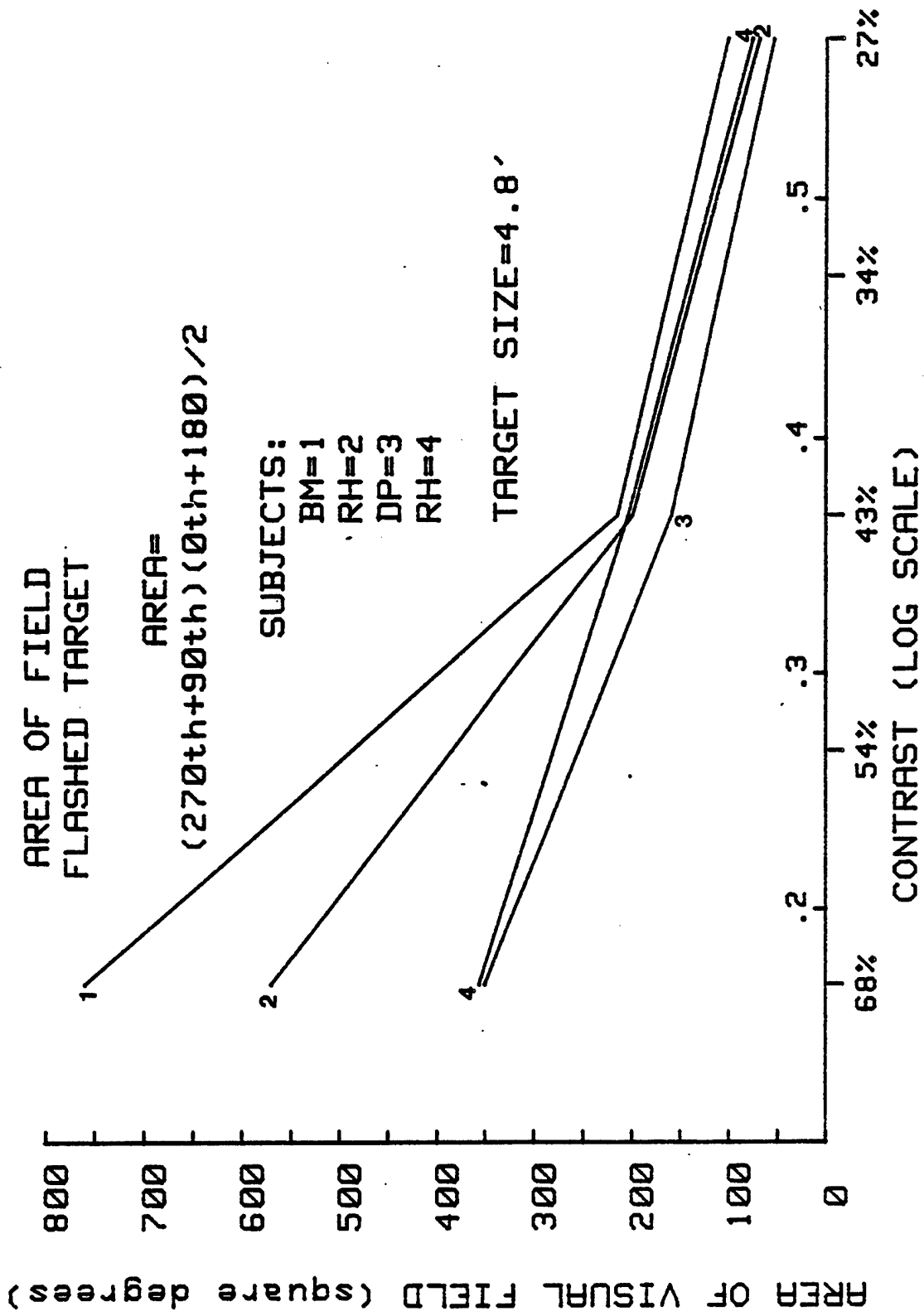

Figure 16

where each meridian is degrees and the area is in square degrees.

With the Saccadic Move and Flashed Target Procedures (III and IV) a definite pattern in the area of the field functions is noted between subjects. Subjects BM and RH show a significant change in the slope beyond 200 square degrees. Subject DH has a linear relationship between the area of the field and log contrast change in stimulus with a linear regression correlation of .99 for both procedures. With the Fixed Target Procedure (II) subjects BM and RH have parallel slopes of the function of area size with velocity change. Subjects DP and DH also have parallel functions. The difference between subjects for Procedure II is most apparent between velocities 1 and 4 deg/s. Subjects BM and RH have less of field increase than subjects DP and DH with a decrease in velocity in this range. With the Moving Target Procedure (I), subjects BM and RH show similar functions with the greatest increase in field size occurring between 1 and 4 deg/s. It was also noted that subjects BM and RH had a change in the symmetry of the fields for Procedure II compared to the other procedures. The actual size of the visual fields varied up to a factor of approximately two for a given stimulus condition among the four subjects. Subject DP was the oldest subject (age 54) and averaged smaller visual field sizes than the other subjects on all procedures. The area of the visual field for subject DP was consistently the smallest of the subjects at higher movement velocities in the dynamic procedures and at lower contrast in the static procedures. Subject DH was the youngest subject (age 30) and tended to show the largest area of visual field of the subjects for the higher velocities in the dynamic procedures.

However, subject DH did not show similar trends in the static procedures. A much larger sample size and age span would be required to determine a differential between dynamic and static procedures in relation to age.

When the areas of the visual fields for each procedure are averaged for the four subjects and graphed, the resulting plots are very similar for the dynamic procedures (I and II) and the static procedures (III and IV) (Figures 17 and 18). Procedure II appears to produce a larger size visual field than Procedure I for a given velocity. However, the difference appears to be mainly from subject DP, and is possibly due to a luminance calibration error.

D. Comparison Between Procedures (Table 4-7)

The four different procedures were compared for each subject and meridian using linear regression analysis. In the dynamic procedures (I and II) target velocity was an additional variable. The velocities for Procedures I and II that averaged similar peripheral field values to Procedures III and IV were selected for analysis.

For a given contrast value, the velocity investigated in the dynamic methods that averaged comparable results in the static methods varied between subjects: DH-16 deg/s, DP-4 deg/s; BM and RH-8 deg/s for 90th and 270th meridian, and 4 deg/s for 0th and 180th meridian. This velocity difference for subjects RH and BM between the vertical and horizontal meridians is most likely due to a difference in methods of measure. The reaction time correction factor used for the horizontal meridians was measured with foveal supra-threshold targets, and the actual procedure required detection of slightly above threshold, peripheral stimuli which would increase the reaction time correction factor.

Figure 17 - Comparison of the area of the visual fields
between Procedures I and II at 43% contrast.

DYNAMIC PROCEDURES
MEANS AND S.D.

AREA=(270th+90th)(0th+180th)/2
MOVING TARGET=1
FIXED TARGET=2
CONTRAST=43%
TARGET SIZE=4.8'
4 SUBJECTS

PROCEDURE 2 IS SHIFTED TO
THE RIGHT BY 1 DEG/S

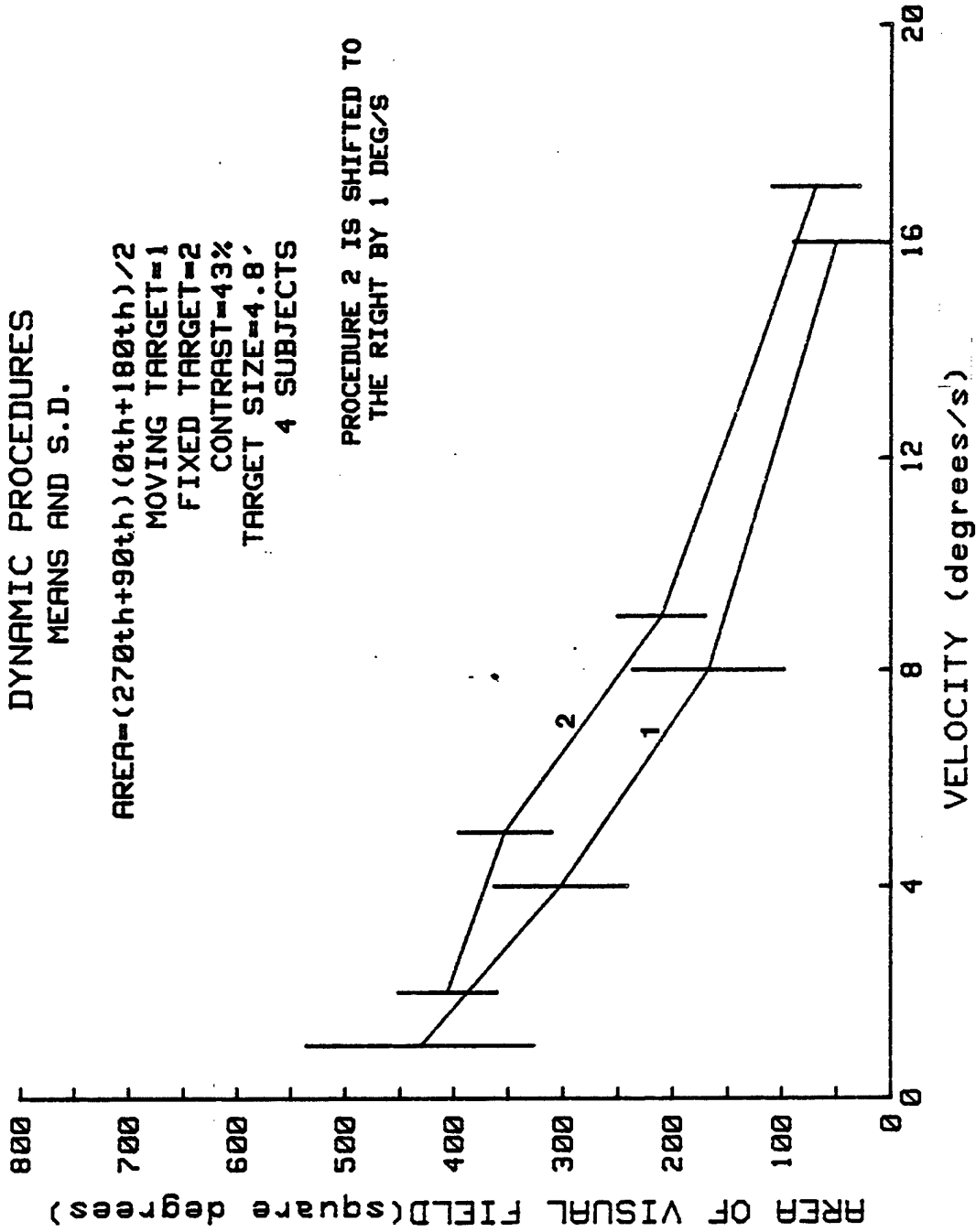

Figure 17

Figure 18 - Comparison of the area of the visual fields
between Procedures III and IV.

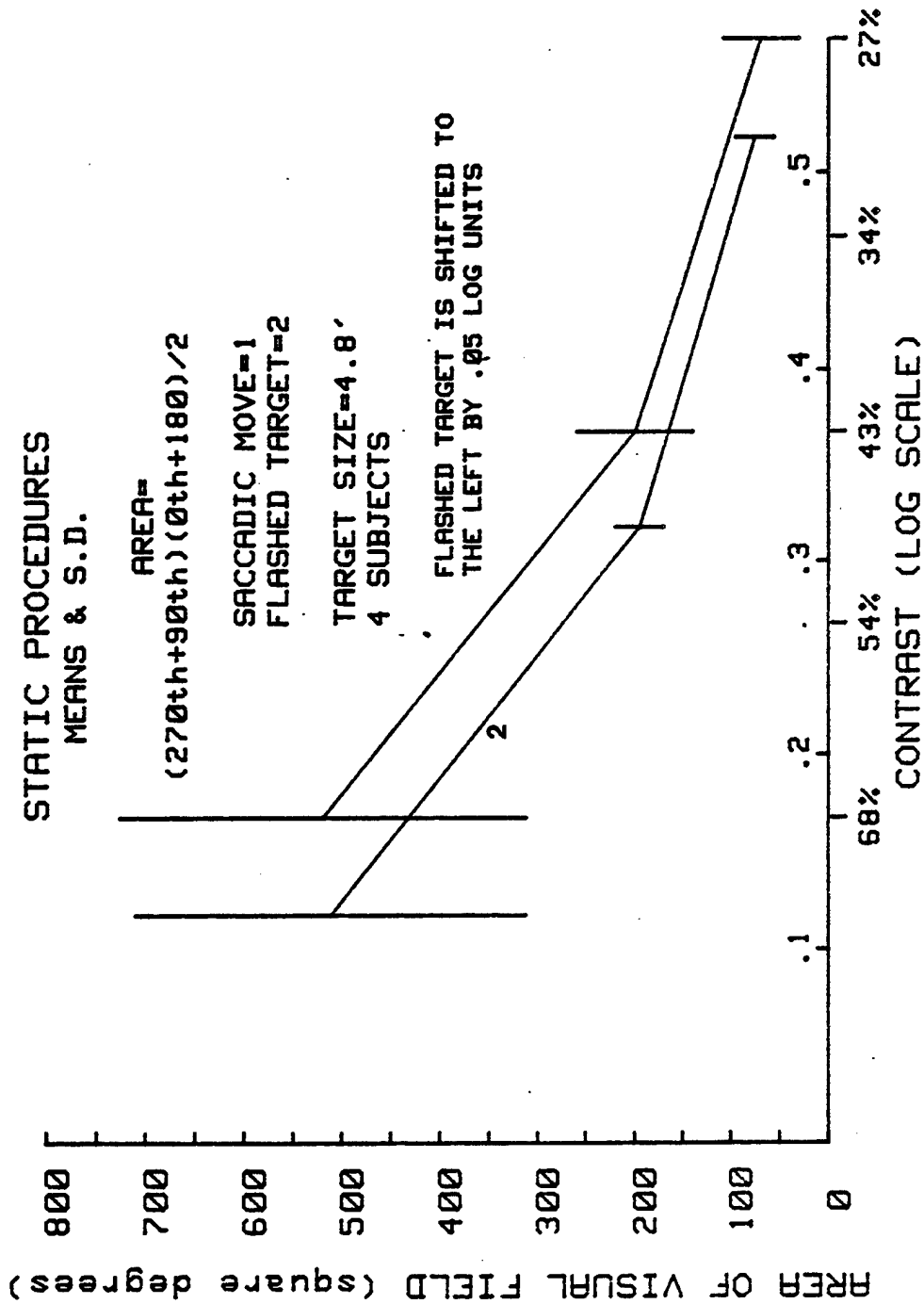

Figure 18

TABLE 4a

Comparison Between Procedures
Linear Regression Analysis
Subject: BM

Procedures (x)	Procedures (y)		
	II	III	IV
I	C=.889 S=.742 I=1.96 \bar{y} =9.64 \bar{x} =10.35 N=19	C=.859 S=.895 I=3.09 \bar{y} =12.63 \bar{x} =10.66 N=20	C=.879 S=1.030 I=1.84 \bar{y} =12.81 \bar{x} =10.66 N=20
II		C=.871 S=1.116 I=1.77 \bar{y} =12.53 \bar{x} =9.64 N=19	C=.839 S=1.209 I=1.050 \bar{y} =12.71 \bar{x} =9.64 N=19
III			C=.964 S=1.083 I=-.87 \bar{y} =12.81 \bar{x} =12.63 N=20

Velocity for Procedures I and II = 8 deg/s
 $y = bx + a$

C=Correlation
S=Slope (b)
I=y Intercept (a)

\bar{y} =mean of y
 \bar{x} =mean of x
N=Number of comparison points

TABLE 4b

Comparison Between Procedures
Linear Regression Analysis
Subject BM

		Procedures (y)			
Procedures (x)	I	II C=.925 S=.952 I=.73 \bar{y} =12.45 x=12.30 N=19	III C=.947 S=.809 I=2.51 \bar{y} =12.63 x=12.51 N=20	IV C=.975 S=.942 I=1.11 \bar{y} =12.71 x=12.30 N=19	
	II		C=.971 S=.810 I=2.45 \bar{y} =12.53 x=12.45 N=19	C=.917 S=.860 I=2.00 \bar{y} =12.71 x=12.45 N=19	
	III			C=.964 S=1.083 I=.87 \bar{y} =12.81 x=12.63 N=20	

Velocity for 180th and 0th meridians
For Procedures I and II = 4 deg/s
Velocity for 90th and 270th meridian = 8 deg/s
 $y = bx + a$

C=Correlation \bar{y} =mean of y
S=Slope (b) \bar{x} =mean of x
I=y Intercept (a) N=Number of comparison points

TABLE 5

Comparison Between Procedures
 Linear Regression Analysis
 Subject DP

		Procedures (y)		
		II	III	IV
Procedures (x)	I		C=.873 S=1.025 I=-.83 \bar{y} =8.56 \bar{x} =9.16	C=.844 S=.805 I=1.91 \bar{y} =9.29 \bar{x} =9.16
	II			
	III			C=.891 S=.735 I=3.04 \bar{y} =9.23 \bar{x} =8.42 N=20

Velocity for Procedure I = 4 deg/s
 Procedure II had error in vertical meridian contrast
 $y = bx + a$

C=Correlation \bar{y} =mean of y
 S=Slope (b) \bar{x} =mean of x
 I=y Intercept (a) N=Number of comparison points

TABLE 6a

Comparison Between Procedures
 Linear Regression Analysis
 Subject RH

		Procedures (y)		
		II	III	IV
Procedures (x)	I	C=.925 S=.893 I=2.99 \bar{y} =12.21 x=10.33 N=10	C=.936 S=.922 I=2.99 \bar{y} =12.91 x=10.77 N=12	C=.922 S=.942 I=1.53 \bar{y} =11.67 x=10.77 N=12
	II		C=.981 S=1.008 I=.36 \bar{y} =12.67 x=12.21 N=10	C=.980 S=1.047 I=-.94 \bar{y} =11.84 x=12.21 N=10
	III			C=.988 S=1.024 I=1.56 \bar{y} =11.67 \bar{x} =12.91 N=12

Velocity for Procedure I and II = 8 deg/s

$$y = bx + a$$

C=Correlation

S=Slope (b)

I=y Intercept (a)

\bar{y} =mean of y

\bar{x} =mean of x

N=Number of comparison points

TABLE 6b

Comparison Between Procedures
Linear Regression Analysis
Subject RH

		<u>Procedures (y)</u>			
		II	III	IV	IV
Procedures (x)	I	C=.987 S=.795 I=3.57 \bar{y} =13.37 \bar{x} =12.33 N=10	C=.979 S=.815 I=2.77 \bar{y} =12.91 \bar{x} =12.44 N=12		C=.979 S=.846 I=1.15 \bar{y} =11.67 \bar{x} =12.44 N=12
	II		C=.988 S=1.018 I=-.95 \bar{y} =12.67 \bar{x} =13.37 N=10		C=.986 S=1.056 I=-2.29 \bar{y} =11.84 \bar{x} =13.37 N=10
	III				C=.988 S=1.024 I=-1.56 \bar{y} =11.67 \bar{x} =12.91 N=12

For Procedures I and II

Velocity = 8 deg/s for 270th and 90th meridians

Velocity = 4 deg/s for 0th and 180th meridians

$$y = bx + a$$

C=Correlation

S=Slope (b)

I=y Intercept (a)

\bar{y} =mean of y

\bar{x} =mean of x

N=Number of comparison points

TABLE 7
 Comparison Between Procedures
 Linear Regression Analysis
 Subject DH

		Procedures (y)		
		II	III	IV
Procedures (x)	I	C=.915 S=.811 I=2.68 \bar{y} =8.51 \bar{x} =7.19 N=12	C=.953 S=.796 I=3.31 \bar{y} =9.04 \bar{x} =7.19 N=12	C=.884 S=.680 I=5.18 \bar{y} =10.07 \bar{x} =7.19 N=12
	II		C=.879 S=.829 I=1.98 \bar{y} =9.04 \bar{x} =8.51 N=12	C=.857 S=.744 I=3.74 \bar{y} =10.07 \bar{x} =8.51 N=12
	III			C=.94 S=.869 I=2.22 \bar{y} =10.07 \bar{x} =9.04 N=12

Velocity for Procedures I and II = 16 deg/s
 $y = bx + a$

C=Correlation
 S=Slope (b)
 I=y Intercept (a)

\bar{y} =mean of y
 \bar{x} =mean of x
 N=Number of comparison points

Using linear regression analysis, the correlations between procedures varied from a low of .84 to a high of .99 for all subjects. Subject RH showed the highest correlations between all procedures. Using 8 deg/s for vertical meridians and 4 deg/s for horizontal meridians for subjects RH and BM improved all correlations between procedures.

E. Relationships Between Change in Contrast and Velocity (Table 8)

The relationship between a change in contrast and an equivalent change in velocity (using Procedure I for each subject) was determined. The data were plotted on fine lined graph paper as in the meridian plots with velocity and degrees of peripheral vision on the axes and connected for each contrast value. Selecting even degrees of peripheral vision at two degree intervals for a given meridian, the velocity value was determined for each contrast value by interpolation. For example, for subject BM, Procedure I, 180th meridian at 8 degrees of peripheral vision: 27% contrast=3.6 deg/s velocity, 34%=9.5 deg/s, 43%=13.2 deg/s, 54%=17.6 deg/s. The difference between the velocity values for all the meridians was averaged for a corresponding log difference in contrast for each subject, i.e. $5.9 + 3.7 + 4.2 = 13.8/3$ (average 4.6 deg/s increase is equivalent to a .1 log contrast decrease).

The average increase in velocity for all subjects and meridians to an equivalent .1 log decrease of contrast for the Moving Target Procedure was 3.9 deg/s, $\pm .53$ S.D. The range of averaged meridian values for all subjects was from 2.50 to 4.98 deg/s. The range of averaged subject values was from 3.30 to 4.30 deg/s. Fig. 19 are plots of contrast and velocity for the 90th and 180th meridians

TABLE 8

Target velocity increase (deg/s) per .1 log contrast decrease at equal retinal locations with moving target procedure

Meridian	90th (N)	270th (N)	0th (N)	180th (N)	4 Meridians
<u>Subject BM</u>					
Mean	3.60 (13)	4.35 (14)	4.28 (18)	4.94 (18)	$\bar{X} = 4.30$
S.D.	.97	.44	.91	.89	S.D. = .89
<u>Subject RH</u>					
Mean	3.93 (4)	3.88 (4)	3.72 (5)	3.98 (6)	$\bar{X} = 3.88$
S.D.	.49	.66	.93	.98	S.D. = .11
<u>Subject DP</u>					
Mean	3.36 (8)	2.50 (8)	3.53 (8)	3.91 (7)	$\bar{X} = 3.30$
S.D.	.37	.87	.71	1.33	S.D. = .64
<u>Subject DH</u>					
Mean	3.98 (2)	3.99 (3)	4.40 (4)	4.08 (3)	$\bar{X} = 4.11$
S.D.	.11	.22	1.43	2.08	S.D. = .20
\bar{X}	3.72	3.68	3.98	4.23	3.90
S.D.	.29	.81	.42	.48	.53

Figure 19 - Plot of the relationships between contrast and velocity for a given retinal location.

CONTRAST VS VELOCITY
AT EQUAL RETINAL POINTS
MOVING TARGET
90th meridian
SUBJECT: BM

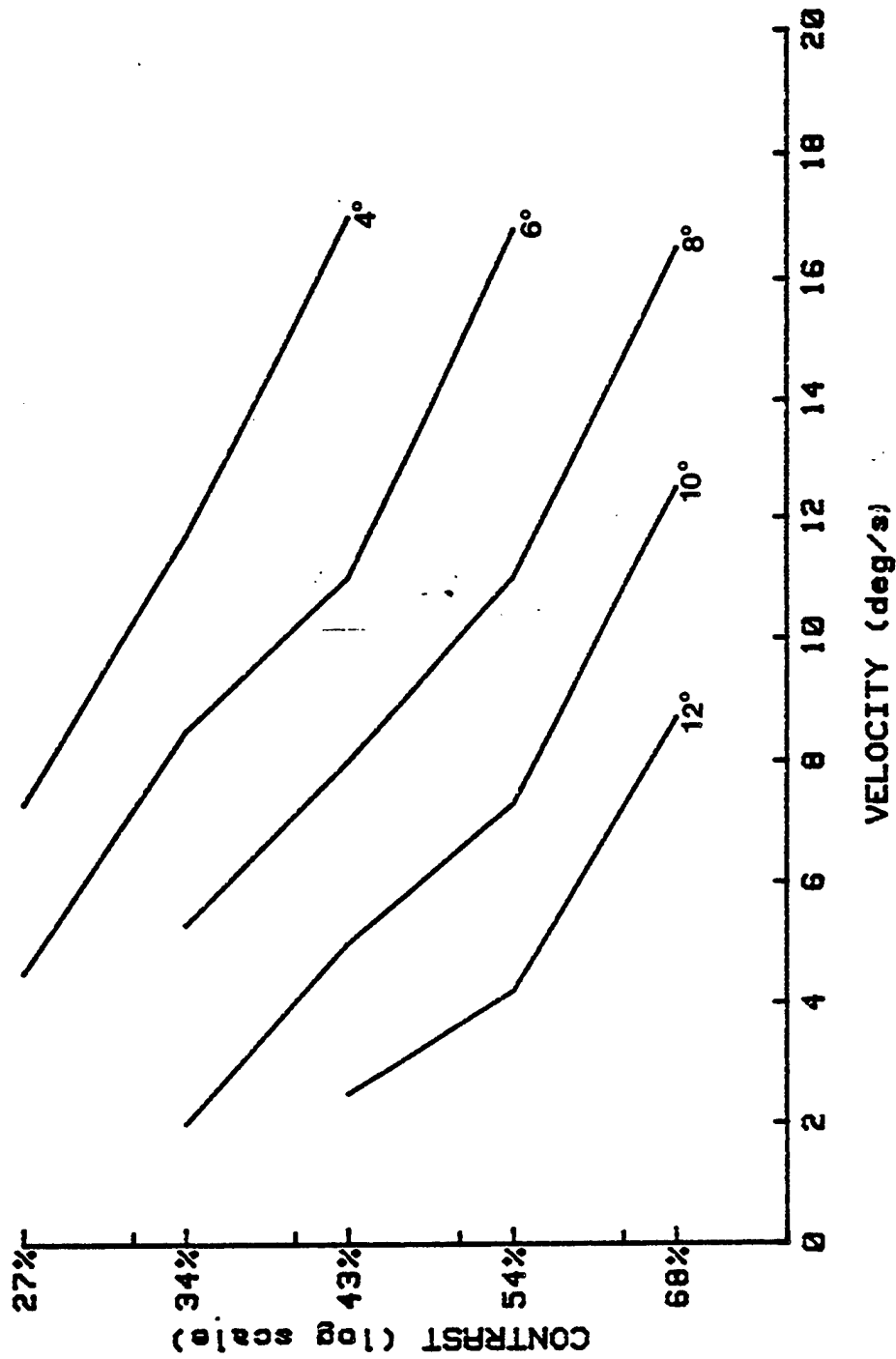

Figure 19A

CONTRAST VS VELOCITY
 AT EQUAL RETINAL POINTS
 MOVING TARGET
 100th meridian
 SUBJECT: BM

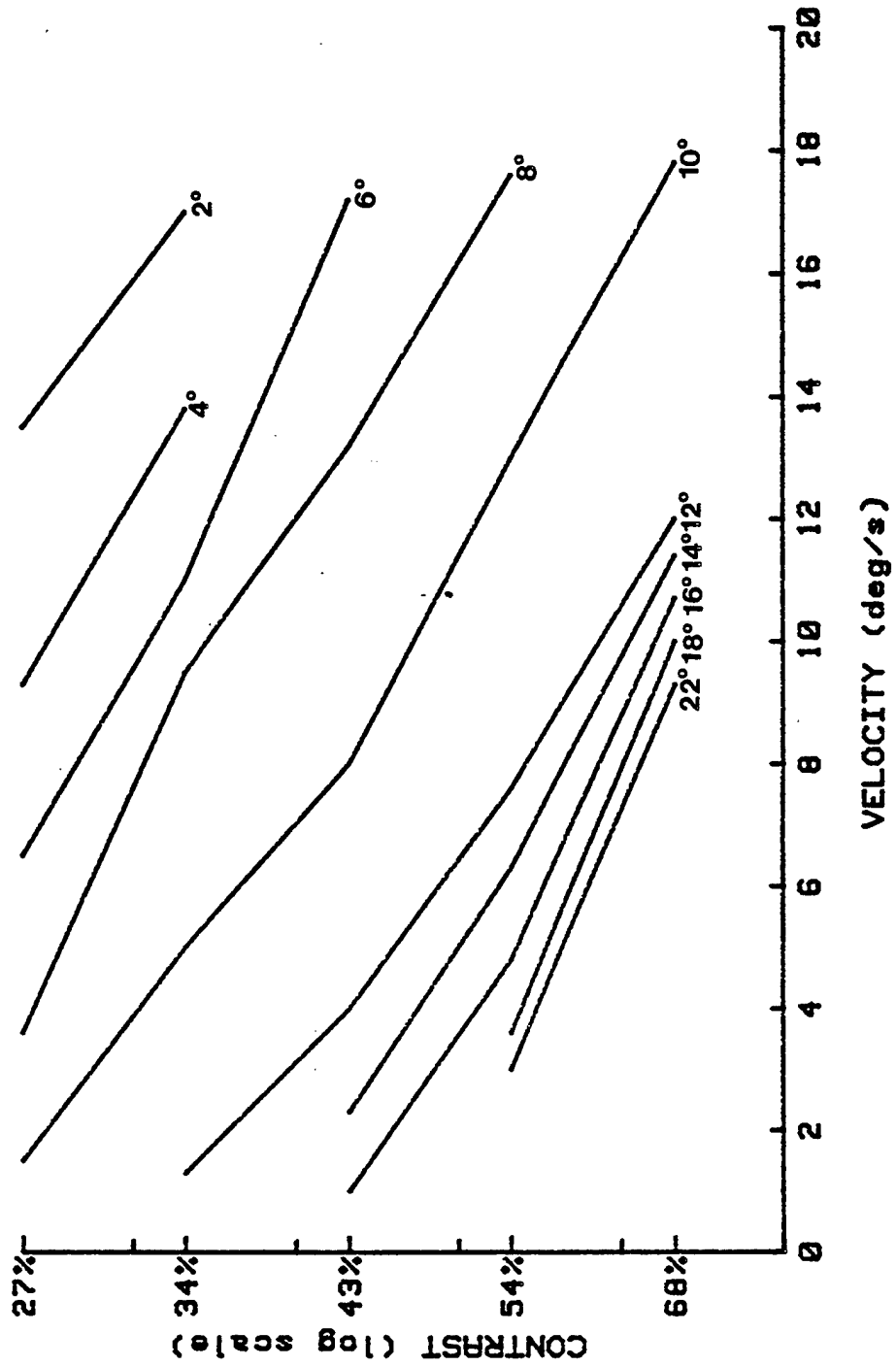

Figure 19B

CONTRAST VS VELOCITY
AT EQUAL RETINAL POINTS
MOVING TARGET
90th meridian
SUBJECT: DP

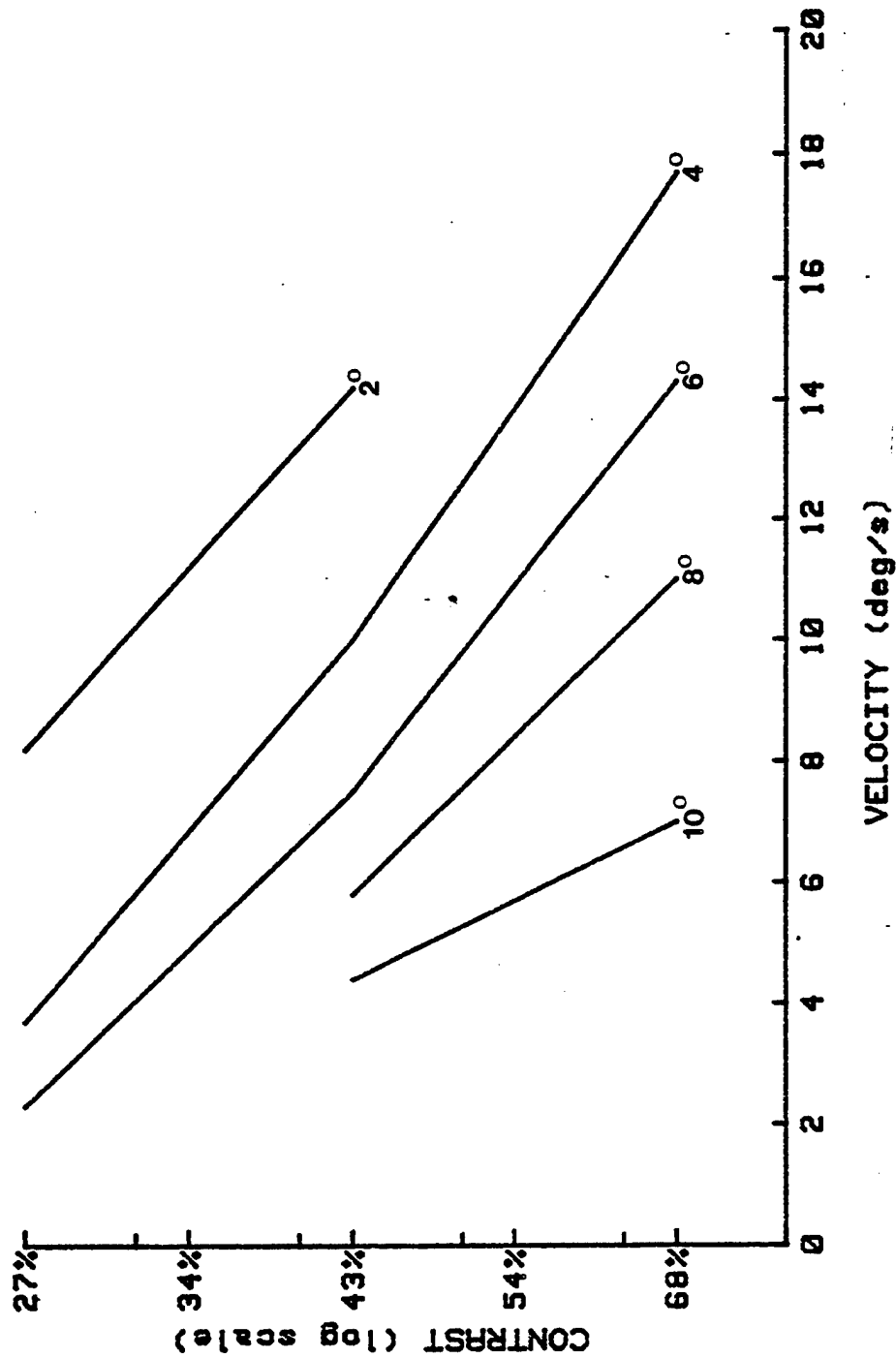

Figure 19C

CONTRAST VS VELOCITY
AT EQUAL RETINAL POINTS
MOVING TARGET
180th meridian
SUBJECT: DP

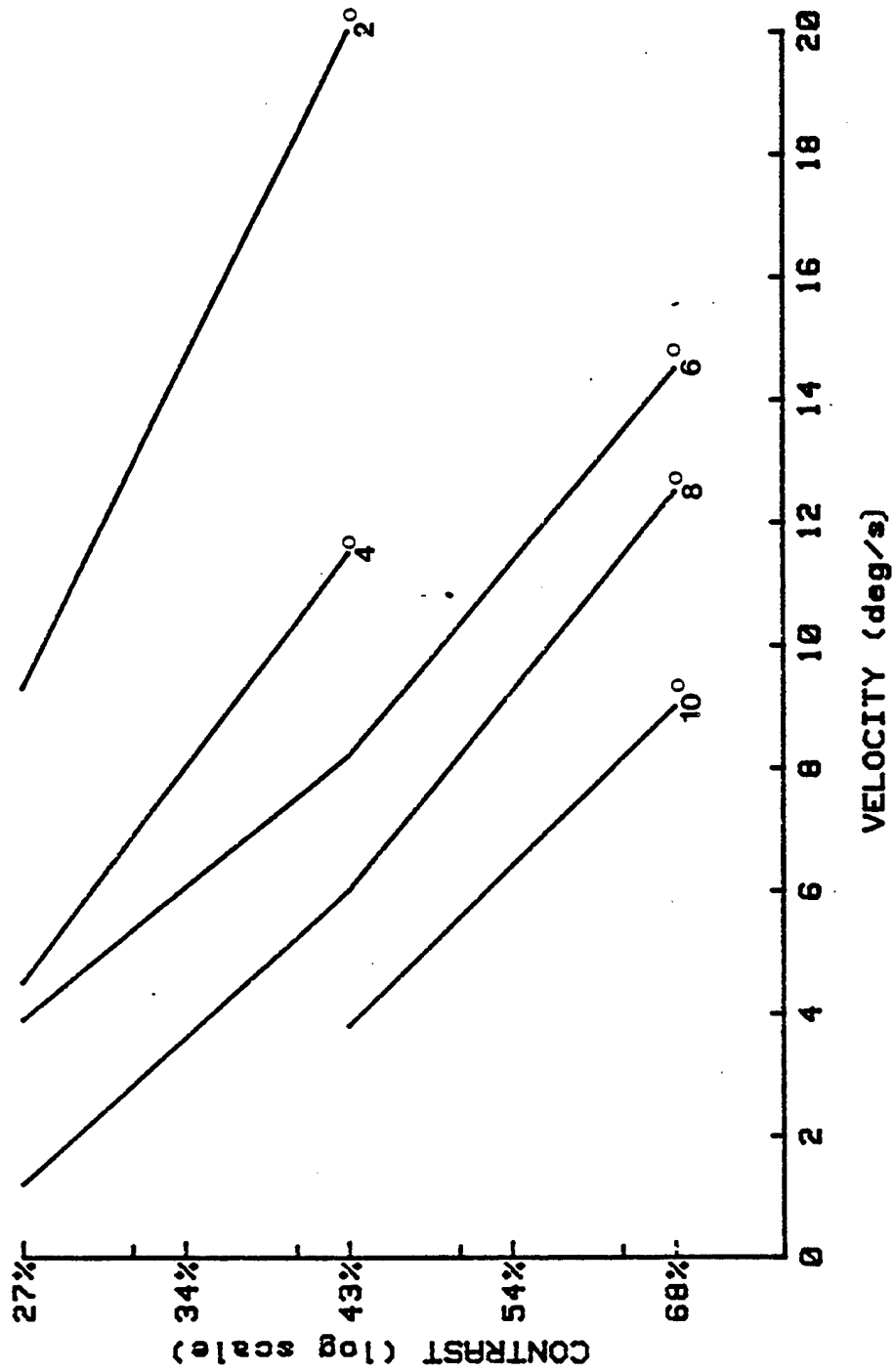

Figure 19D

for subjects BM and DP using Procedure I. Additional meridian plots are located in Appendix E.

Since the .5 log range of this study represented contrast values of 27 to 68% and each .1 log change in this range represented only 7% (27 to 34%) and 14% (54 to 68%) difference in contrast, the linear velocity change could be related to a linear contrast change. Then a 10% contrast change would equate to a 3.8 deg/s change in velocity averaged for all subjects and meridians. One would expect this linear to linear relationship for a given point on the retina (Bloch's Law). However, a linear to linear plot of contrast and velocity does not significantly improve the linear relationship. The rapidly moving circular target appears as a dimmer line from retinal smear and temporal summation. Bouman (1953) and Lamar (1947) have studied the total flux related to area and elongation of a target. With a length to width ratio of 2 and 7, a five factor increase in area from 10 to 50 square minutes showed a contrast threshold decrease of approximately .5. The shape, area, contrast, and temporal variables investigated within a limited range with this study, and predicting contrast and velocity relationships beyond the investigated limits may not show a linear function.

F. Relationship Between $1/P_{sg}$ and Mean Detection Time (Fig. 20E)

This section compares the mean detection times taken from a search study by Krendel and Wodinsky (1960) with single glimpse probability calculations (reciprocal) obtained in this study. The stimuli variables are equivalent in both studies, and the measured visual field sizes were taken from the saccadic movement procedure (III). The reciprocal of single glimpse probability ($1/P_{sg}$) is the ratio of the

Figure 20 - Relationship Between Mean Detection Time and the Reciprocal of Single Glimpse Probability.

COMPARISON OF MEAN DETECTION TIME AND SINGLE GLIMPSE PROBABILITY

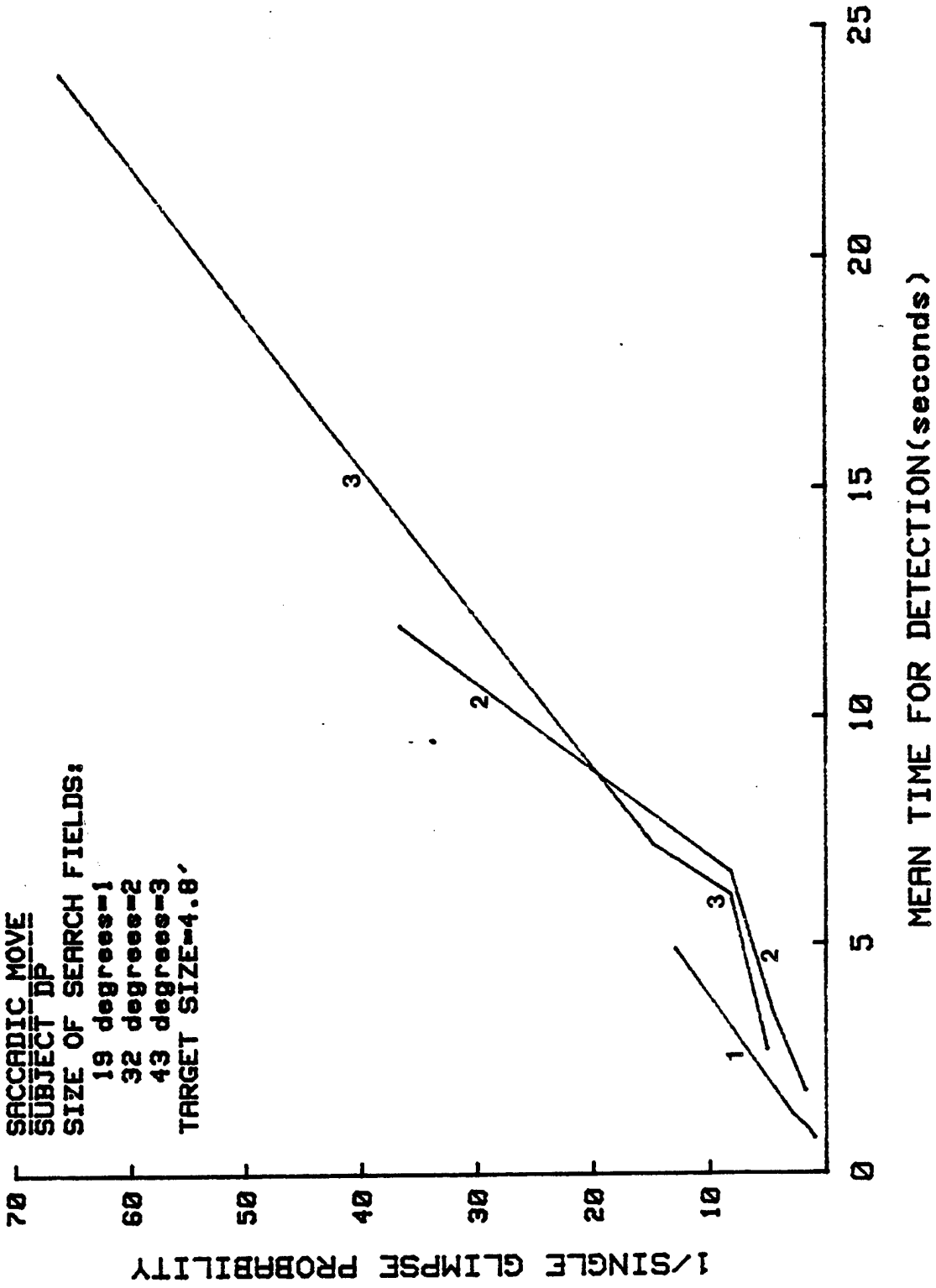

Figure 20A

COMPARISON OF MEAN DETECTION TIME AND SINGLE GLIMPSE PROBABILITY

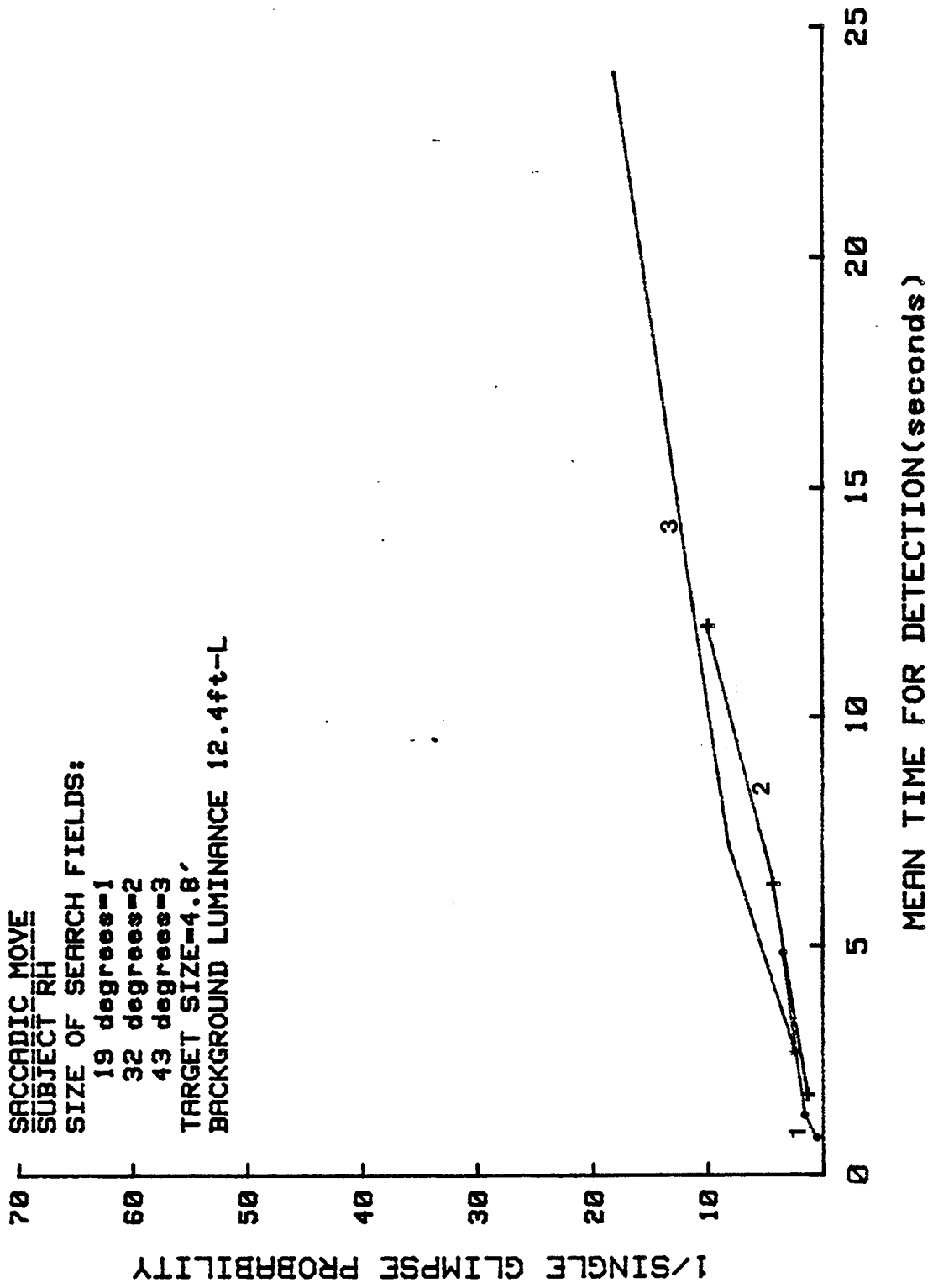

Figure 20B

COMPARISON OF MEAN DETECTION TIME AND SINGLE GLIMPSE PROBABILITY

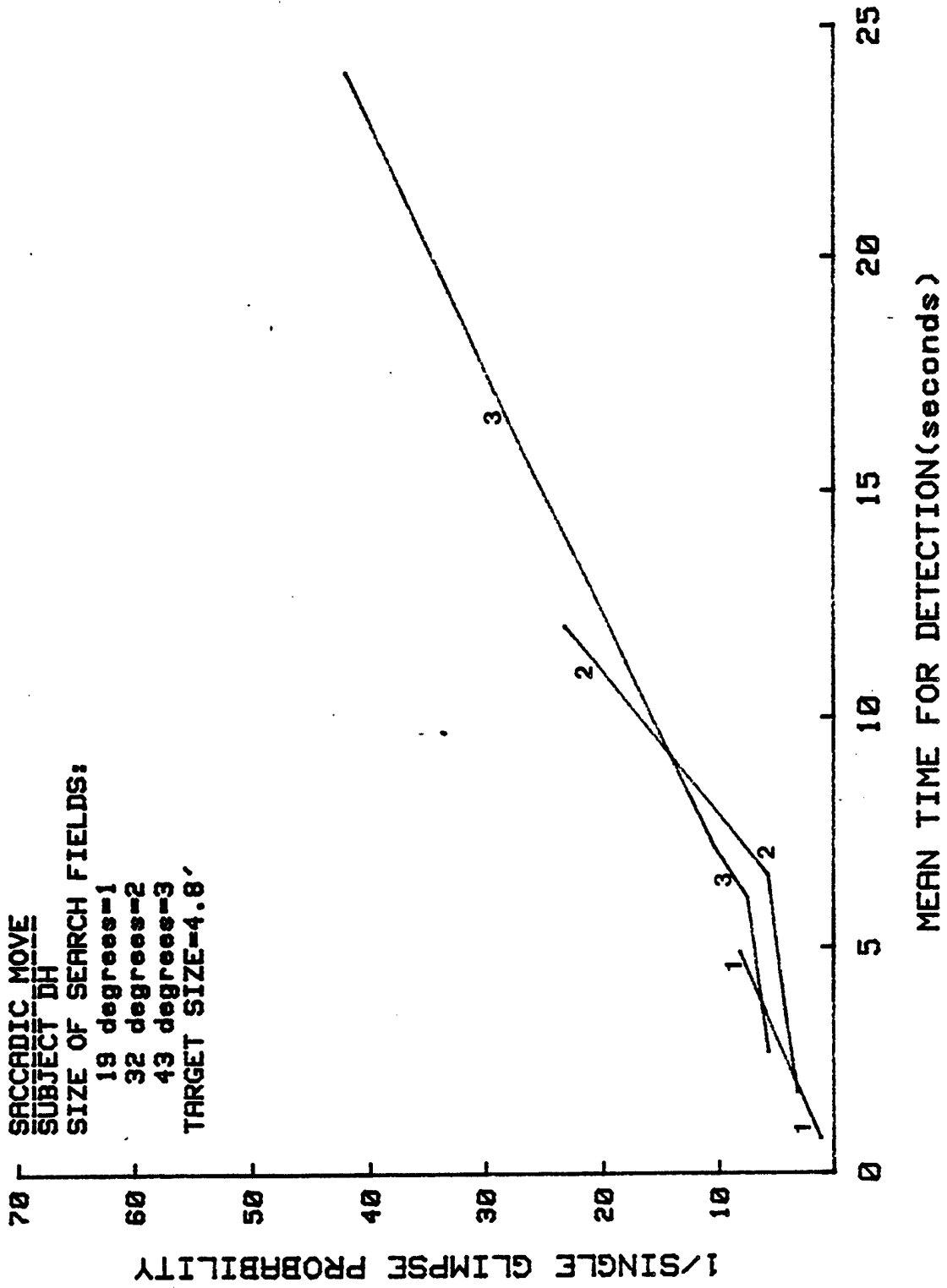

Figure 20C

COMPARISON OF MEAN DETECTION TIME AND SINGLE GLIMPSE PROBABILITY

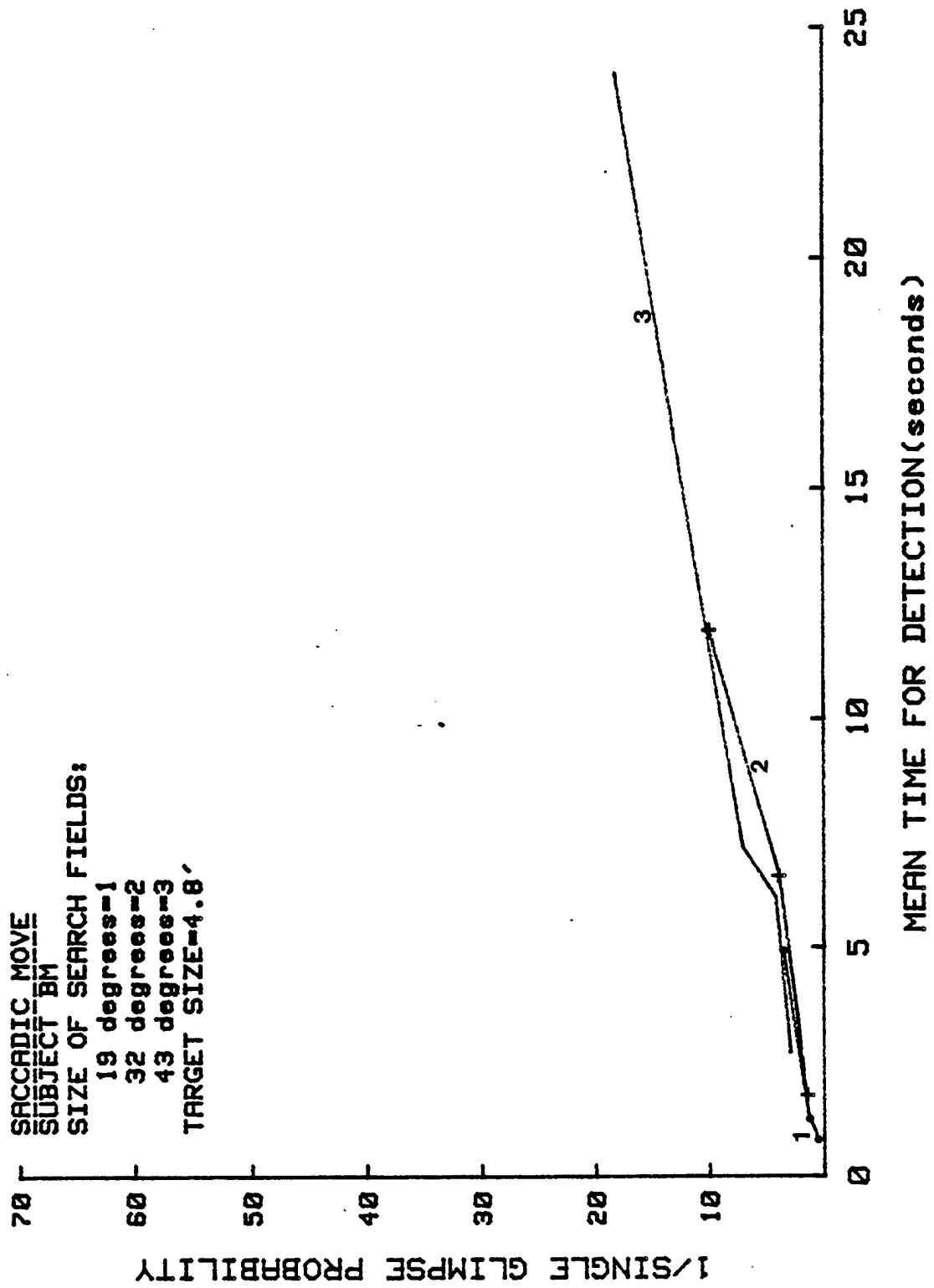

Figure 20D

MEAN DETECTION TIME AND SINGLE GLIMPSE PROBABILITY

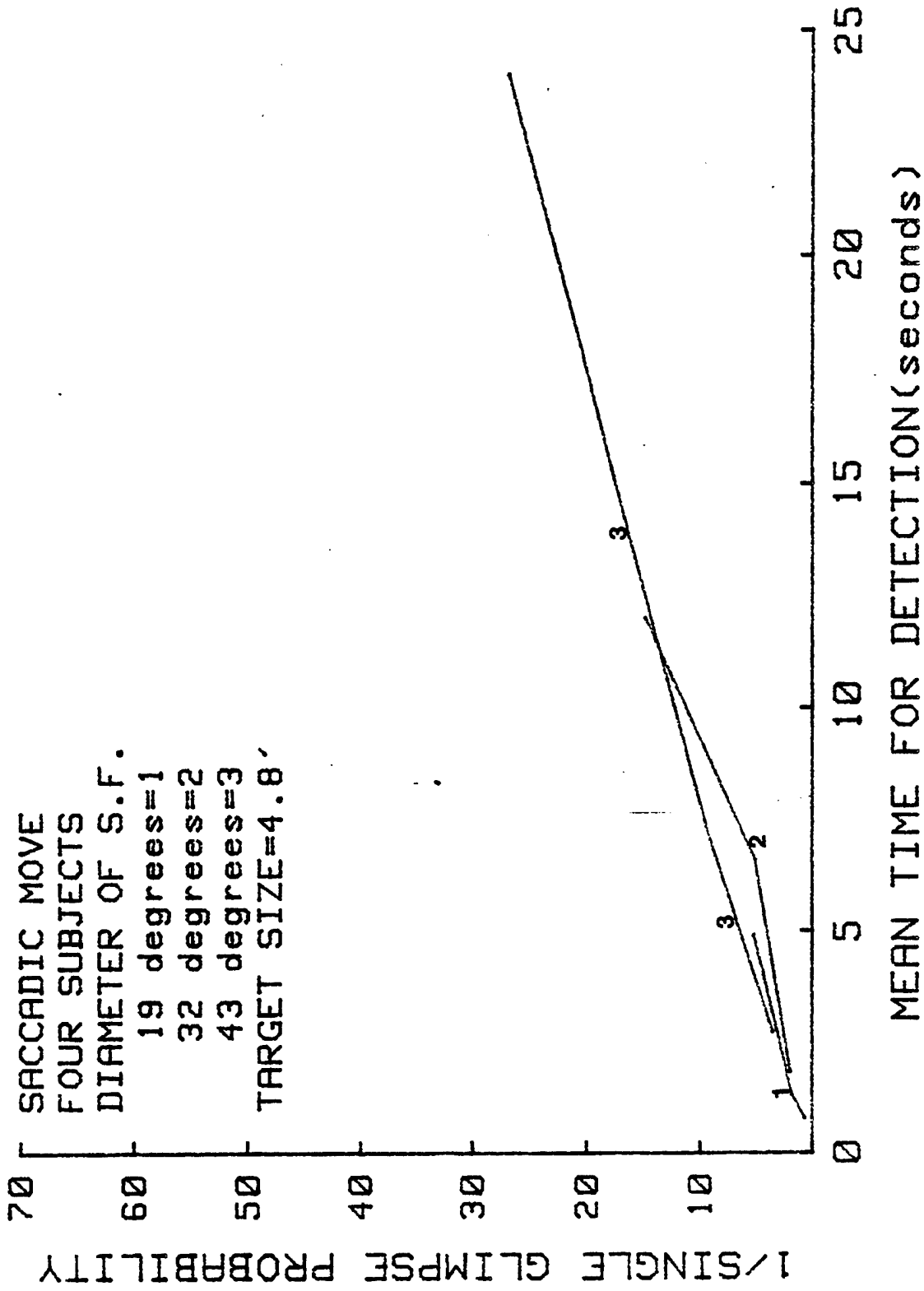

Figure 20E

size of the search area to the size of the visual lobe for a given target.

When the mean detection times taken from the Krendel and Wodinsky (K&W) study are plotted with the reciprocal of the relative single glimpse probability ($1/P_{sg}$) from this study using regression analysis, the correlation ranges from .98 to .99 for all subjects (Fig. 20E). This correlation was made with procedures III, and is slightly misleading since 10 of the 12 mean detection times range from .78 to 8.2 seconds. The other two detection times are 12 and 24 seconds. When the 12 and 24 second detection times are excluded, the correlation ranges from .88 to .93 and the slopes are different. The calculated values of P_{sg} for a given contrast and area searched varied by a factor of 3 between subjects DH and DP. This means the time between glimpses would have to be three times shorter for subject DP to have the same mean detection time as subject DH; or for a given interval between glimpses for both subjects, DP would have a mean detection time 3 times longer than subject DH. Tabled values and regression analysis for each subject, search area, contrast, and mean detection times are in Appendix F.

Using the reflex sighting device, subject BM showed .99 correlation between mean detection time and relative ($1/P_{sg}$). The correlation was .92 when the 12 and 24 second detection times were excluded (Fig. 21). The relationship between $1/P_{sg}$ or relative $1/P_{sg}$ and mean detection time shows good correlations for all procedures for subject BM except for Procedure I at 12 deg/s (Table 9).

Taking the average P_{sg} for the 4 subjects in this study for three search areas and four contrast values in the Krendel and Wodinsky study the mean search time was calculated using the expression $P_{kg}=1-(1-P_{sg})^k$,

Figure 21 - Relationship between mean detection time and the reciprocal of relative single glimpse probability for subject BM measured with a reflex sighting device.

COMPARISON OF MEAN DETECTION TIME AND SINGLE GLIMPSE PROBABILITY

RELEX SIGHT DEVICE
 SUBJECT BM
 SIZE OF SEARCH FIELDS:
 19 degrees=1
 32 degrees=2
 43 degrees=3
 TARGET SIZE=4.8'

RELATIVE SINGLE GLIMPSE
 PROBABILITY DEFINED AS:
 $(\theta \text{th MERIDIAN})^2 / \text{SEARCH AREA}$

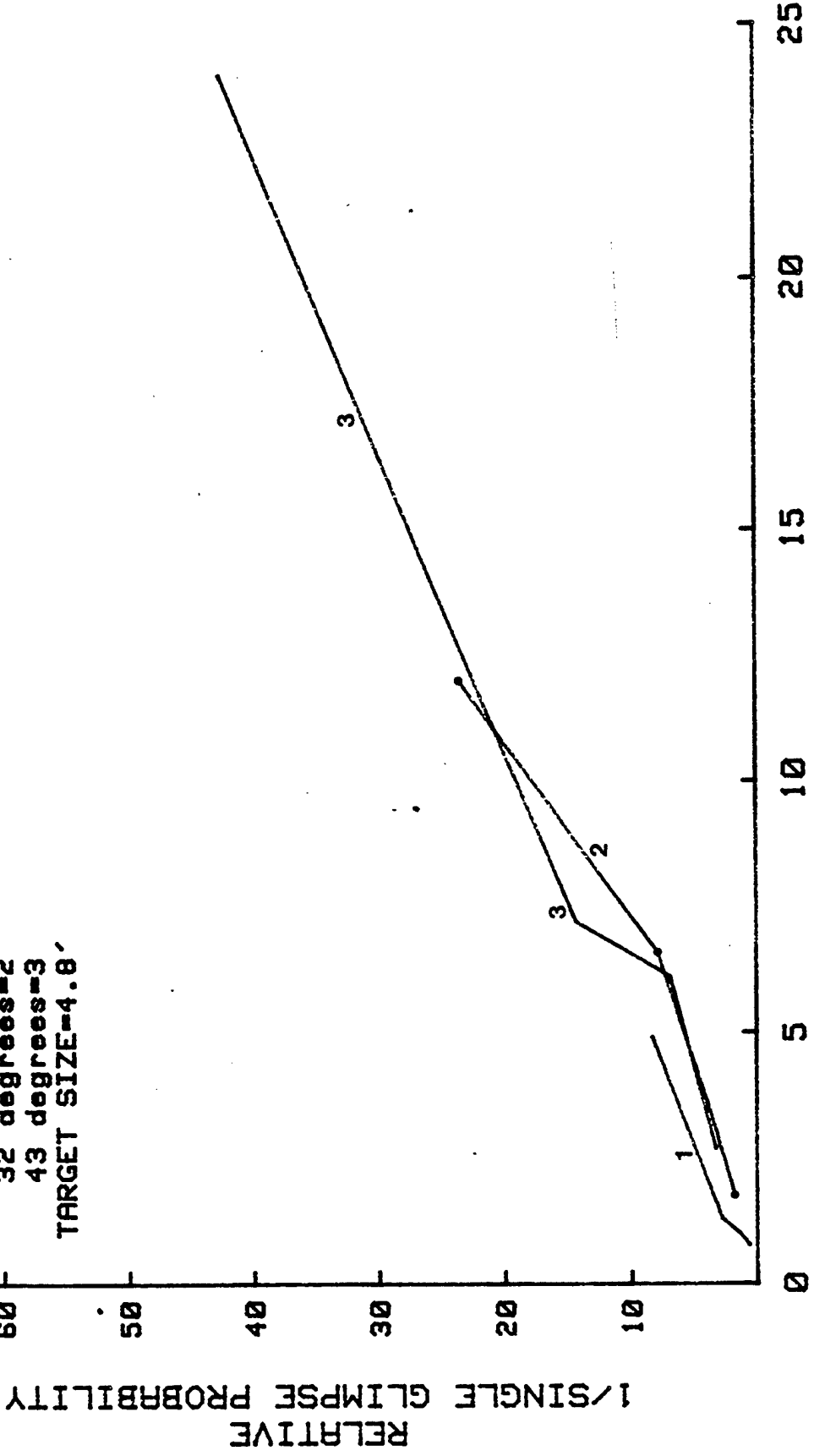

MEAN TIME FOR DETECTION(seconds)

Figure 21

TABLE 9

Mean Detection Time vs. Relative $1/P_{sg} =$
 (Diameter of area searched/[0th Meridian])²

		Subject BM					
		Relative $1/P_{sg}$					
SEARCH FIELD SIZE	Mean Time	4°/s Pro II	Pro III	Reflex Sight	Pro IV	12°/s Pro I	4°/s Pro I
	(19°) ² =	.78	.52	.72	.64	.52	2.12
361 Sq. deg.	1.0	1.93	1.21	1.34	.79	3.07	1.04
	1.3	2.81	1.89	2.78	1.75	4.28	1.90
	4.9	5.2	3.50	8.79	3.35	38.05	4.09
(32°) ² =	1.8	1.48	2.04	1.82	1.48	6.01	1.25
1024 Sq. deg.	3.5	5.48	3.43	3.80	2.24	8.71	2.95
	6.6	7.98	5.36	7.89	4.96	12.14	5.39
	*12.0	14.75	9.93	23.51	9.51	107.95	11.59
(43°) ² =	2.7	2.66	3.69	3.29	2.66	10.86	2.25
1849 Sq. deg.	6.1	9.89	6.20	6.86	4.05	15.72	5.33
	7.2	14.39	9.68	14.25	8.96	21.92	9.73
	*24.0	26.63	17.93	42.46	17.16	194.89	20.95
Correlation		.97	.97	.99	.97	.96	.98
Slope		1.13	.73	1.84	.72	8.52	.89
Intercept		1.06	1.07	-1.28	.45	-15.53	.22
*without 12 & 24 s data points	C	.92	.91	.92	.89	.67	.93
	S	1.65	1.01	1.58	.91	2.97	1.06
	I	-.70	.14	-.57	-.19	1.63	-.38

$y = bx + a$
 $y = \text{relative } 1/P_{sg}$
 $x = \text{mean time to detect}$
 from K & W

assuming a .33 second interval between glimpses (Ford, 1959), (Krendel and Wodinsky, 1960) and a Pkg of .50. The calculated mean search times were approximately four times faster than reported in the Krendel and Wodinsky study. If Pkg is assumed to be .70 (log function) where the average detection time (mean) would be larger than the fifty percentile detection time, the calculated mean search times are two times faster than those found. If Pkg is calculated for the mean times in Krendel and Wodinsky's study, the values are greater than .92.

DISCUSSION

Contrast vs. Velocity:

It was anticipated that relative movement of a target to a fixation point would enhance detection with peripheral vision up to a given velocity and then reduce detection with increasing velocities. However, the decrease in peripheral visual fields was not expected in the low velocity range of 1 to 4 deg/s nor the magnitude of decrease at 16 to 20 deg/s. This would explain the variability of visual fields clinically taken with kinetic perimetry. With the limited velocity and contrast range investigated in this study an accurate prediction of the relationship between contrast and velocity at greater values is speculative. However, the decrease in contrast with increased velocity could explain saccadic suppression.

Matin (1974) has a good review of saccadic suppression. The causes of the suppression can be listed generally as retinal or centrally located with strong evidence supporting both. The rapid movement of an image over the retina has been referred to as the retinal smear factor in saccadic suppression. Latour (1962) found suppression of a spot stimulus 3 log units above threshold during saccadic eye movements. The amount of suppression varied depending upon when the test stimulus was presented in relationship to the movement of the eyes. Latour showed that the suppression begins 40 msec before the cessation of eye movement, implying a central suppression mechanism. Young (1975) reviewed eye movement measuring techniques and reported a 30 msec delay with a photodiode and recorder method as used by

Latour. Since the direction of the suppression and the duration of the eye movement recordings were the same, the nonreported delay could account for the lack of synchronization between the suppression and recorded eye movement. The duration of the eye movement was 150 msec. Westheimer (1954) found a typical 20 degree saccadic movement lasting approximately 100 msec with eye movement velocities peaking to 400 deg/s. If log contrast changes are related to linear velocity changes for velocity ranges above 20 deg/s, then a 3 log decrease in threshold for a fixed target would require a retinal rotational velocity of approximately 120 deg/s. If linear contrast changes are related to linear velocity changes, and a 4 deg/s increase in velocity is approximately equal to 10% decrease in contrast, then a 3 log decrease in threshold would require a 250 deg/s velocity increase.

Constant vs. Variable Visual Lobe Size with Target Velocity:

If the data supported a constant size visual lobe for a stationary target, and the measured decrease in the mean field size for a moving target was due to the probability of the target occurring during a glimpse or a visual off cycle, then the standard deviations of the measured values should increase with increased velocity. Looking at the results of the Moving and Fixed Target procedures for the vertical meridians (90th and 270th) beginning at 4 deg/s velocity, the standard deviations do not increase with increased velocity. The decrease in the field sizes does approximate Bloch's Law $(I \times T) = C$ for short duration stimuli. However, as mentioned in Section E of the results, this relationship is complicated by the apparent change in shape of the target during temporal summation. Using the Moving Target procedures with

higher velocities and contrast values may have shown a clearer relationship between velocity and contrast, and the variability of the visual lobe. By determining the threshold of the direct of movement for a visible high velocity spot and varying the visual angle of exposure, the theoretical visual clock or temporal component of successive images could possibly be determined and quantified.

Relationship Between $1/P_{sg}$ and Mean Detection Time:

The search model used in Krendel and Wodinsky's study would have underestimated the mean search time for the measured P_{sg} values found in this study. This discrepancy could be due to the following factors: (1) Lamar's (1964) search model which assumes random fixations may not be valid. (2) The average time interval between fixations for extended search may be greater than the assumed .33 seconds. (3) The actual target contrast values in Krendel and Wodinsky's study may have been significantly less than reported, thereby reducing P_{sg} . (4) The size of the visual lobes measured in this study after a saccadic eye movement may be larger for a given target than would be perceived in an actual search task. (5) The visual responses from the subjects in this study may not be comparable to responses in the Krendel and Wodinsky study.

The possibility of using a portable moving fixation point with a constant velocity to evaluate suprathreshold target visibility appears promising. Visual search studies have been used to evaluate the visibility of targets for camouflage and conspicuity enhancement applications. Because of the extreme inherent variability of such data, the number of trials required to show a significant difference is large, resulting

in high cost in man-hours and expense. This study suggests that relative single glimpse probability can be measured directly and is highly correlated with relative detection time for a given target stimulus. Future research is planned to further investigate these relationships.

CHAPTER IV

SUMMARY AND CONCLUSIONS

Using a 3.05 meter radius screen which subtended a visual angle of 170 degrees horizontally by 33 degrees vertically, photopic binocular visual fields were determined for four primary meridians using a 4.8' target diameter with four subjects. Variables investigated were target and eye movement velocity, contrast, and eye fixation before and after a saccadic eye movement. For the experimental parameters used in this study relative target or smooth eye movement increased the visual field size up to approximately 2 deg/s, and decreased the size thereafter with increasing velocities. A linear change in velocity appears to have an equivalent log change in contrast at a given retinal location for small circular targets within the velocity range investigated of 2-20 deg/s. The relationship between the reciprocal of relative single glimpse probability determined in this study and mean search time taken from a study by Krendel and Wodinsky (1964) appear to have a linear relationship and are highly correlated.

The results of the procedures where the eyes moved in relation to a fixed target or where the target moved in relation to steady eye fixation were very similar. Also, the visual fields were similar before or after a saccadic eye movement.

REFERENCES

- Aulhorn, E. Harms, H., (1972) Visual Perimetry, In Jameson D. Hurrich LM (eds) Handbook of Sensory Physiology. Berlin, Springer Verlag.
- Barnes, J.A., Doss, N.W., (1976) Camouflage Application Test, HEL-TM-32-76, Human Engineering Laboratory, Aberdeen Proving Ground, Md.
- Barnes, J.A., (1972) Analysis of Pilot's Eye Movements During Helicopter Flight, HEL-TM-11-72, Human Engineering Laboratory, Aberdeen Proving Ground, Md.
- Bartlett, N.R., MacLeod, S., (1954) Effect of Flash and Field Luminance upon Human Reaction Time, J. Opt. Soc. Am., 44, 306-311.
- Blackwell, H.R., (1946) Contrast Thresholds of the Human Eye. J. Opt. Soc. Am., 37, 531-545.
- Bouman, M.A., (1953) Visual Thresholds for Line-Shaped Targets, J. Opt. Soc. Am., 43, 209-211.
- Brindley, G.S., (1959) The Discrimination of After-images, J. Physiology. 147, 194-203.
- Burg, A., (1968) Lateral Visual Field as Related to Age and Sex, J. Appl. Psychol., 52, 10-15.
- Chisum, G.T., (1977) Prediction of Airborne Target Detection, NADC-77102-40, Naval Air Development Center, Washington, D.C.
- Clement, W.F., (1967) A Re-examination of Eye Movement Data, Systems Technology, Inc., Hawthorne, Cal.
- Daithch, J.M., Green, D.G., (1969) Contrast Sensitivity of the Human Peripheral Retina. Vision Res., 9, 947-952.

- Dugas, D.J., (1966) Probability of Visual Detection of Reconnaissance Aircraft by Ground Observer, Rand Corp., Santa Monica, Cal.
- Duntley, Seibert, Q., (1948) The Visibility of Distant Objects, J. Opt. Soc. Am., 38, 237-249.
- Enoch, Jay M., (1959) Effect of the Size of a Complex Display Upon Visual Search, J. Opt. Soc. Am., 49, 208-286.
- Fankhauser, F., Schmidt, T., (1960) Die Optimalen Bedingungen für die Untersuchung der räumlichen Summation mit stehender Reizmarke nach der Methode der quantitativen Lichtsinperimetrie, Ophthalmologica, 139, 409-423.
- Farrimond, Thomas, (1967) Visual and Auditory Performance Variations with Age, Australian J. of Psychol., 19(3), 193-201.
- Ford, A., White, C.T., (1959) and Lichtenstein, M., Analysis of Eye Movements During Free Search. J. Opt. Soc. Am., 49, 287-292.
- Fowler, F.D., (1971) Target Acquisition Studies, Martin Marietta Corp., Orlando, Fla.
- Gasson, A.P., Peters, G.S., (1965) The Effect of Concentration Upon the Apparent Size of the Visual Field in Binocular Vision, Part II, The Optician, 149, 5-12.
- Goldman, H., (1945) Grundlagen exakter Perimetrie, Ophthalmologica, 57.
- Gordon, J.I., (1964), Visual Search, Appl. Optics, 3, 591-596.
- Graham, W., (1974) Results of the Visual Detection Simulation Experiment for Evaluation of Aircraft Pilot Warning Instruments, Control Data Corp., St. Paul, Minn.
- Grindley, (1968) Voluntary Attention in Peripheral Vision and its Effect on Acuity and Differential Thresholds. Q. J. Exp. Psychol., 20, 11-19.

- Harrington, D.O., (1964) *The Visual Fields*, 2d ed., St. Louis, C.V. Mosby Co.
- Harvey, L.O., Jr., Poppel, E., (1972) Contrast Sensitivity of the Human Retina, Am. J. Optom., 49, 748-753.
- Hutchins, C.W., (1978) The Relationship Between Air Combat Maneuvering Range (ACMR) Output Measures and Initial Visual Acquisition Performance, Naval Aerospace Medical Research Laboratory, NAMRL-SR-79-1, Pensacola, Fla.
- Krendel, E.S., Wodinsky, J., (1960) Search in an Unstructured Visual Field, J. Opt. Soc. Am., 562-568.
- Lamar, E.S., Hecht, S., Shlaer, S., Hendley, C.D., (1947) Size, Shape, and Contrast in Detection of Targets by Daylight Vision, J. Opt. Soc. Am., 37, 531-454.
- Latour, P.L., (1962) Visual Threshold During Eye Movements, Vision Res., 2, 261-262.
- Link, J.M., (1969) Differential Thresholds for Motion in the Periphery. NASA-CR-1439, Washington, D.C.
- Mackworth, N.H., (1965) Visual Noise Causes Tunnel Vision. Psychon. Sci., 3, 67-78.
- Martin, E., (1974) Saccadic Suppression: A Review and an Analysis. Psychol. Bull., 81, 899-907.
- Mertens, J.J., (1956) Influence of Knowledge of Target Location Upon the Probability of Observation of Peripherally Observable Test Flashes. J. Opt. Soc. Am., 46, 1069-1070.

- Nachimas, J., (1967) Effect of Exposure Duration on Visual Contrast Sensitivity with Square-Wave Gratings. J. Opt. Soc. Am., 57, 421-427.
- Neisser, U., Novick, R., Lazar, R., (1963) Searching for Ten Targets Simultaneously. Perceptual and Motor Skills, 17, 959.
- Nurdygin, P. Ya., (1968) Studies of the Psychophysical Capabilities of the Visual Analyser from the Discrimination of Signals by Peripheral Vision. Translation from Aerospace Medicine, USSR, Oct.
- Overington, Ian, (1976) Vision and Acquisition. Pentek Press, London.
- Pirenne, M.H., (1943) Binocular and Monocular Threshold of Vision, Nature, 152, 698-699.
- Ronchi, L., (1970) Time Course of Perceptual Probability on Prolong Testing at Various Eccentricities. Vision Res., 10, 605-607.
- Salvatore, S., (1972) Perception of Real Motion; A Literature Review (Public Health Service).
- Sanders, A.F., (1967) Information Processing in the Functional Visual Field, NASA, Washington, D.C.
- Sloan, L.L., (1961) Area and Luminance of Test Object as Variables in Examination of the Visual Field by Projection Perimetry. Vision Res., 1, 121-138.
- Synder, H.L., Taylor, D.F., (1976) Computerized Analysis of Eye Movements During Static Display, Virginia Polytechnic Inst. and State University, Blacksburn, Va.
- Starr, A., (1969) Visual Suppression During Smooth Following and Saccadic Eye Movements, Vision Res., 9, 195-197.
- Tate, G.W., Jr., Lynn, J., (1977) Principles of Quantitative Perimetry, Grune & Stratton, Inc.

- Traquari's Clinical Perimetry (1957), 7th ed. by G.I. Scott, St. Louis, C.V. Mosby, Co.
- Vallerie, L.L., Link, J.M., (1968) Visual Detection Probability of Sonar Targets as a Function of Retinal Position and Brightness Contrast. Hum. Factors, 10, 403-412.
- Van den Brink, G., Bouman, M.A., (1957) Visual Contrast Thresholds for Moving Point Sources, J. Opt. Soc. Am., 47, 612-618.
- Volkman, F.C., (1962) Vision During Voluntary Saccadic Eye Movements. J. Opt. Soc. Am., 52, 571-578.
- Westheimer, G., (1954) Eye Movement Responses to a Horizontally Moving Visual Stimulus. Arch. Ophthalmol., 52, 932-941.
- White, C.T., (1964) Ocular Behavior in Visual Search. Appl. Optics, 3, 569-570.
- White, C.T., Ford, A., (1960) Eye Movements During Simulated Radar Search, J. Opt. Soc. Am., 50, 909-913.
- Williams, L.G., (1966a) Target Conspicuity and Visual Search. Hum. Factors, 8, 80-92.
- Williams, L.G., (1966b) A Study of Visual Search Using Eye Movement Recordings, Honeywell, Inc., St. Paul, Minn., Jun.
- Wright, D.A., (1966) The Performance of Ground Observers in Detecting, Recognizing, and Estimating Range of Low Altitude Aircraft. George Washington University, Alexandria, Va.
- Yarbus, A., (1967) Eye Movements and Vision. Translated from Russian by Basil Haigh, Plenum Press, New York.
- Young, L.R., (1975) Eye-Movement Measuring Techniques, Am. Psychol., 30, 315-330.